



ZEISS Metrology Software

Overview



**When you find easy solutions
to challenging tasks.**

ZEISS Metrology Software



One system for every task

ZEISS software: overview

Standard geometries

Page 6



ZEISS CALYPSO

Universal metrology software
focused on standard geometries

Options for ZEISS CALYPSO

Page 10



CURVE
Evaluate curves



CAD import
CAD import options



FREEFORM
Evaluate freeform surfaces



DMIS
DMIS import and
DMIS export



PCM
Parts families



qs-STAT
Export for qs-STAT

Page 12



PLANNER
Generate measurement
plans off-line



PRESET
Erosion electrodes



FACS
Measure random samples



PTI
Polygon clamping devices



BASIC AUTOMATION
Standard automation



BLADE PRO
Turbine blades

Page 14



GEAR PRO
Gear metrology

Freeform surfaces

Page 16



ZEISS CALIGO

Universal metrology software focused on freeform surfaces

Quality data management

Page 20

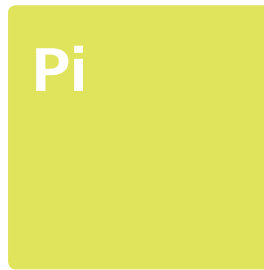

ZEISS PiWeb

Reporting, statistics and quality data management

- **ZEISS PiWeb reporting/ ZEISS reporting plus**
Reporting and statistics
- **ZEISS PiWeb sbs**
Quality data management for small companies
- **ZEISS PiWeb enterprise**
Quality data management for large companies

Other

Page 24



ZEISS colin3D

Optical 3D capture and 3D analysis



ZEISS REVERSE ENGINEERING

Reverse engineering, tool correction



ZEISS iDA

Off-line programming system for car body construction



ZEISS MASTER CONTROL CENTER

Metrology and knowledge management

Reference for standard geometries

ZEISS CALYPSO

With ZEISS CALYPSO, you will measure standard geometries easily, quickly and reliably. A single mouse click on the required characteristics is all that is needed for programming. In combination with measuring machines and sensors from ZEISS, you receive a high-performance system from a single source. Thanks to a large number of options, ZEISS CALYPSO also offers the right tools for special requirements.

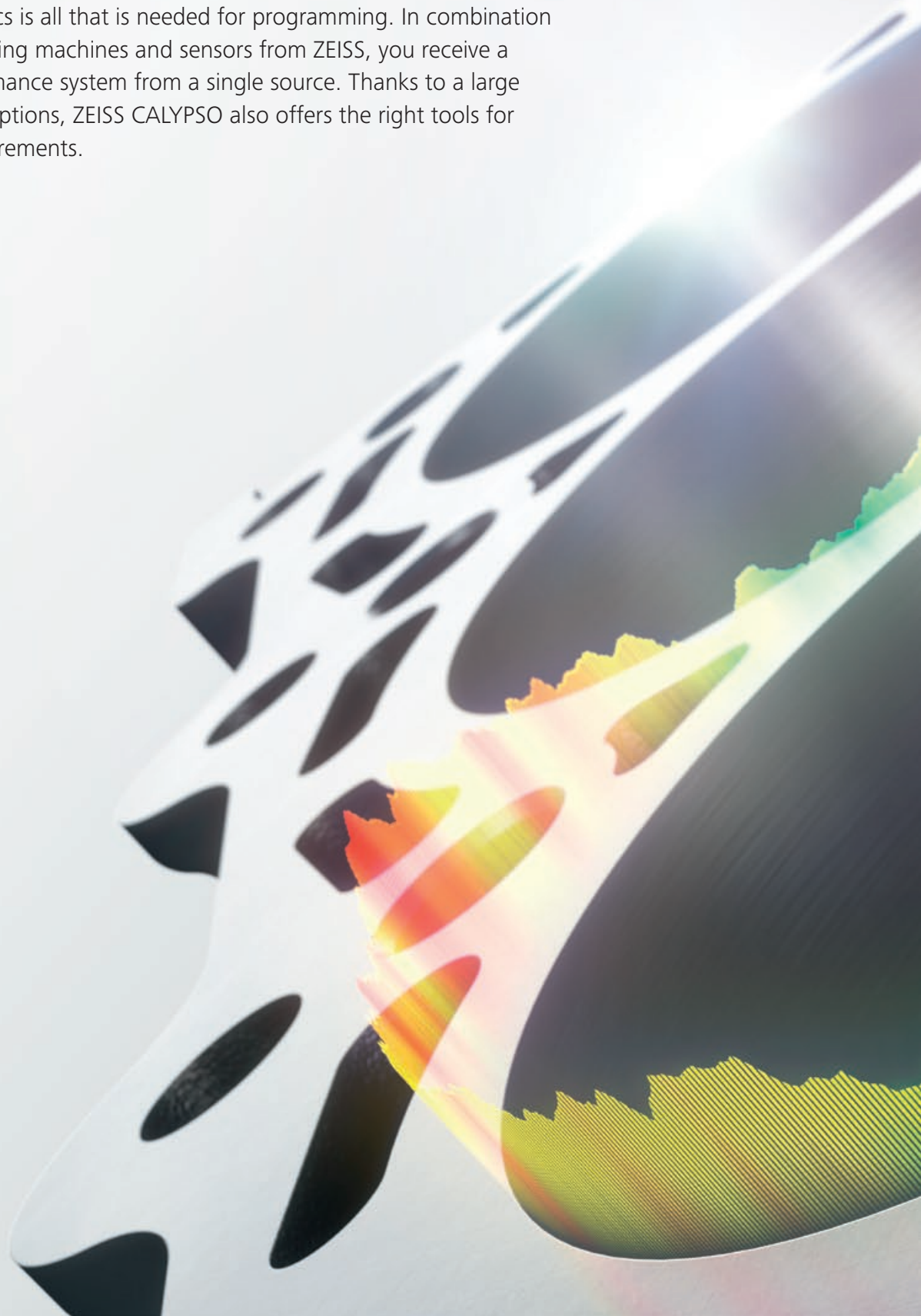

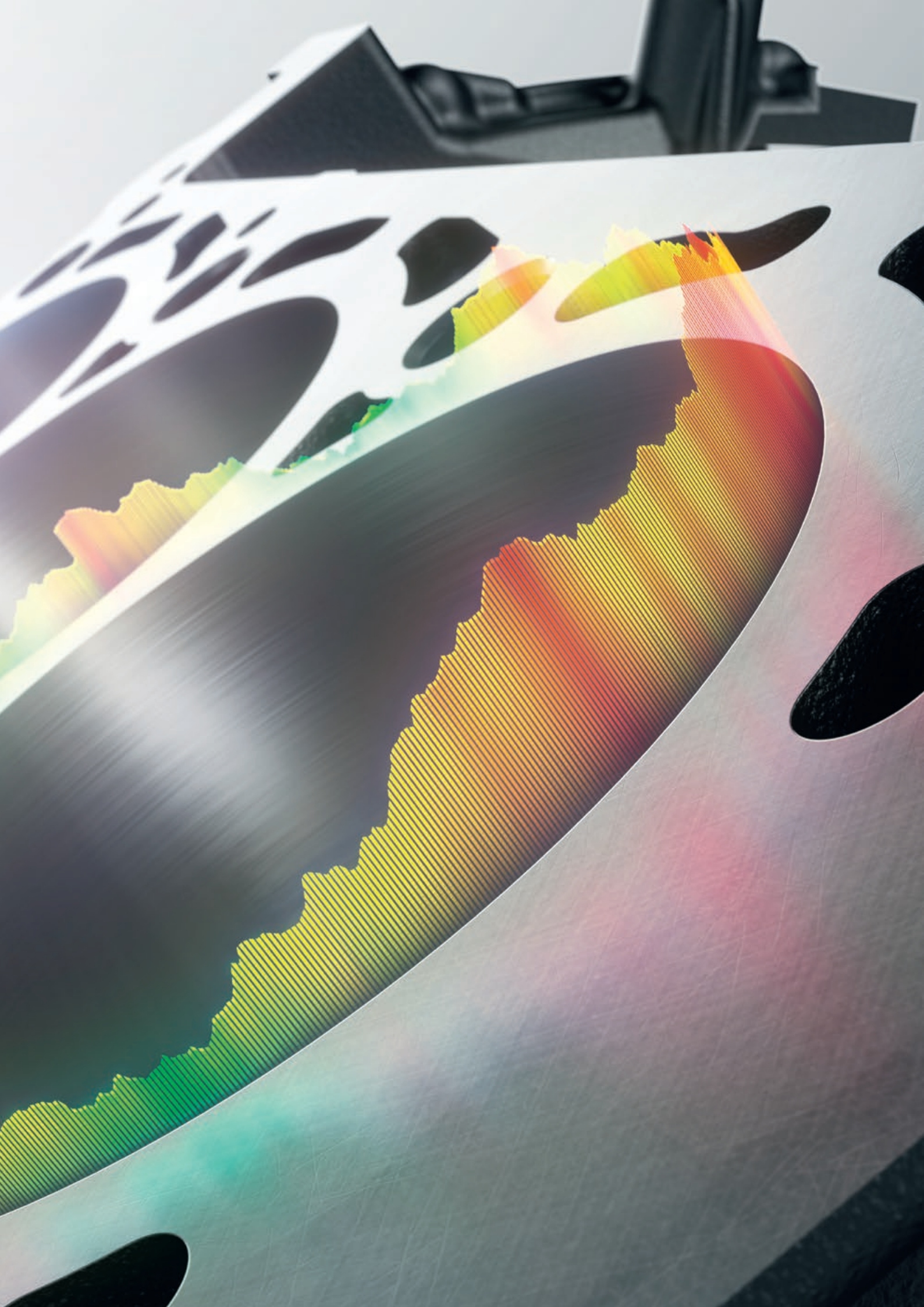



CY

ZEISS CALYPSO

Universal metrology software focused on standard geometries

Highlights

- The ZEISS CALYPSO characteristics strategy – the easy way to get from the drawing to the measurement
- Automatic travel paths
- Automatic, efficient measuring run, no recording of unnecessary features
- CALYPSO PMI: automatic generation of measurement plans using product and manufacturing information in the CAD model
- Includes ZEISS PiWeb reporting: professional and interactive
- I++ DME interface for controlling measuring machines from other manufacturers

A dedicated solution

The drawing shows what characteristics are to be measured: dimensions, position tolerances and form errors. In ZEISS CALYPSO, unlike other measuring programs, these characteristics are also the starting point for programming. Creating the measurement plan is easy to learn, target-oriented and efficient.

The geometric features needed for a characteristic, e.g. circles, lines or planes, are managed separately in ZEISS CALYPSO. This separation of characteristics and features makes ZEISS CALYPSO more flexible, faster and more user-friendly.



More flexibility

- Generate measurement plans with ease and convenience – and in any order you want.
- Change the sequence of measuring runs within your measurement plans the easy way.
- Select any feature from the component drawing and let ZEISS CALYPSO perform an automatic partial measurement for you immediately.

Automatic travel paths

- The travel paths from one feature to another are generated automatically by ZEISS CALYPSO. This avoids collisions and saves you time when generating your measurement plan.

Easier operation

- ZEISS CALYPSO makes it easy to generate the characteristics specified in the drawing and then link them to the corresponding features.

Use CALYPSO PMI to get automatically from the CAD model to the measurement plan

The standard ZEISS CALYPSO package contains the new CALYPSO PMI function. The abbreviation stands for Product and Manufacturing Information. With CALYPSO PMI, size, form and position tolerances contained as PMI in the CAD model can be implemented automatically in the form of measurement plans, hence considerably reducing the user's workload.

ZEISS PiWeb reporting included

ZEISS PiWeb reporting is included with ZEISS CALYPSO on delivery. Use the report templates or generate your own reports or templates. The option ZEISS PiWeb reporting plus allows you to extend the contained statistics function from 10 to 1,000 measurements. The packages ZEISS PiWeb sbs and ZEISS PiWeb enterprise (see pages 22–23) provide you with a complete system for web-based quality data management.

ZEISS CALYPSO Options

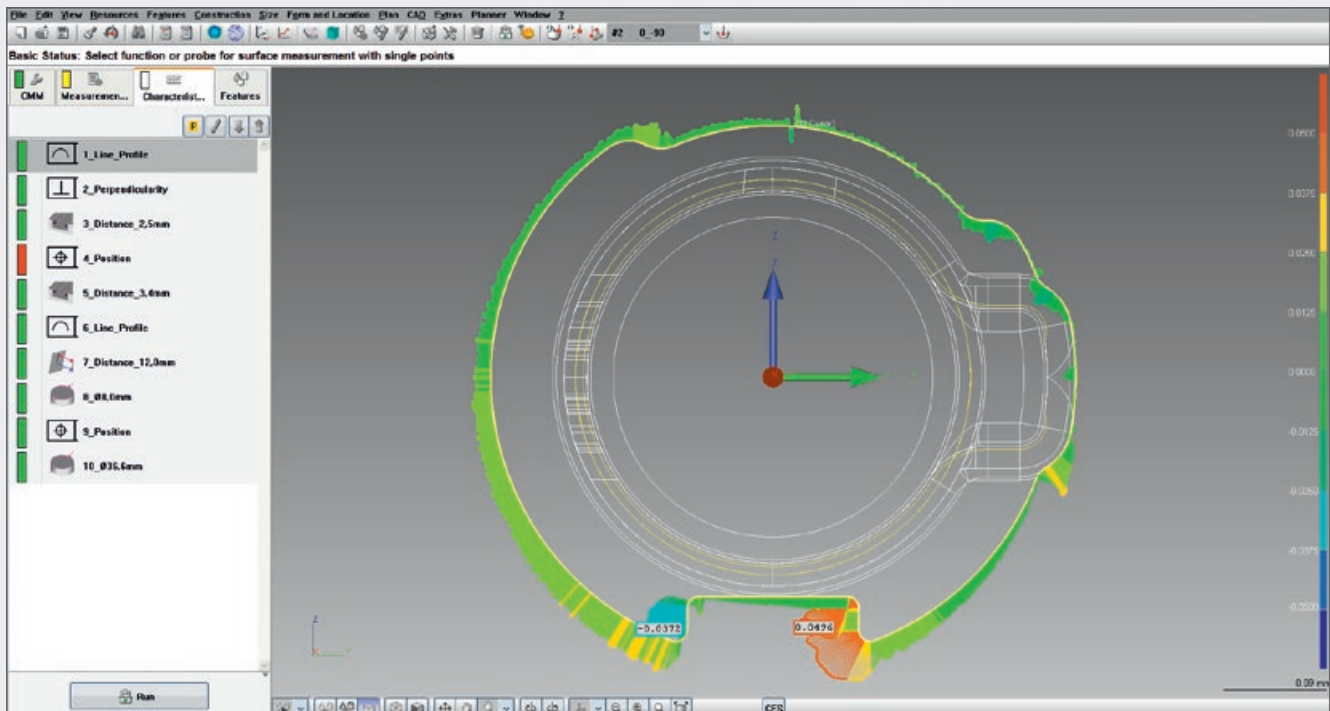

Evaluation of a freeform curve using the CURVE option



CURVE

Evaluate curves

- 2D and 3D curves
- Known and unknown curves
- Open and closed curves

Whether turbo loaders, camshafts or screw compressors – the CURVE option makes it possible to evaluate freeform curves within the standard measuring environment of ZEISS CALYPSO. CURVE is suitable for the testing of known and unknown as well as open and closed 2D and 3D curves. Possible characteristics include curve slope, cam throw, curve length, curve form and surface area. CURVE displays results as, for example, a form plot or as a curve diagram.



FREEFORM

Evaluate freeform surfaces

- Single points, spatial point groups and sections
- Many ways of displaying results

The FREEFORM option is recommended if you want to use ZEISS CALYPSO to test not only standard geometries, but also freeform surfaces. Typical fields of application include medical technology, mold making and engine construction. FREEFORM allows the analysis of single points, spatial point groups and sections on the model. This option offers many different possibilities, types of display and result output. Deviations from plan are marked in color.



PCM

Parts families

- Efficient testing of parts families

PCM (Parameter Coded Measurements) is the efficient way of testing families of similar parts that differ only in a few individual parameters. The varying parameter data are read out and automatically implemented in ZEISS CALYPSO measurement programs. PCM additionally offers many different possibilities for tailoring ZEISS CALYPSO programs to specific requirements.

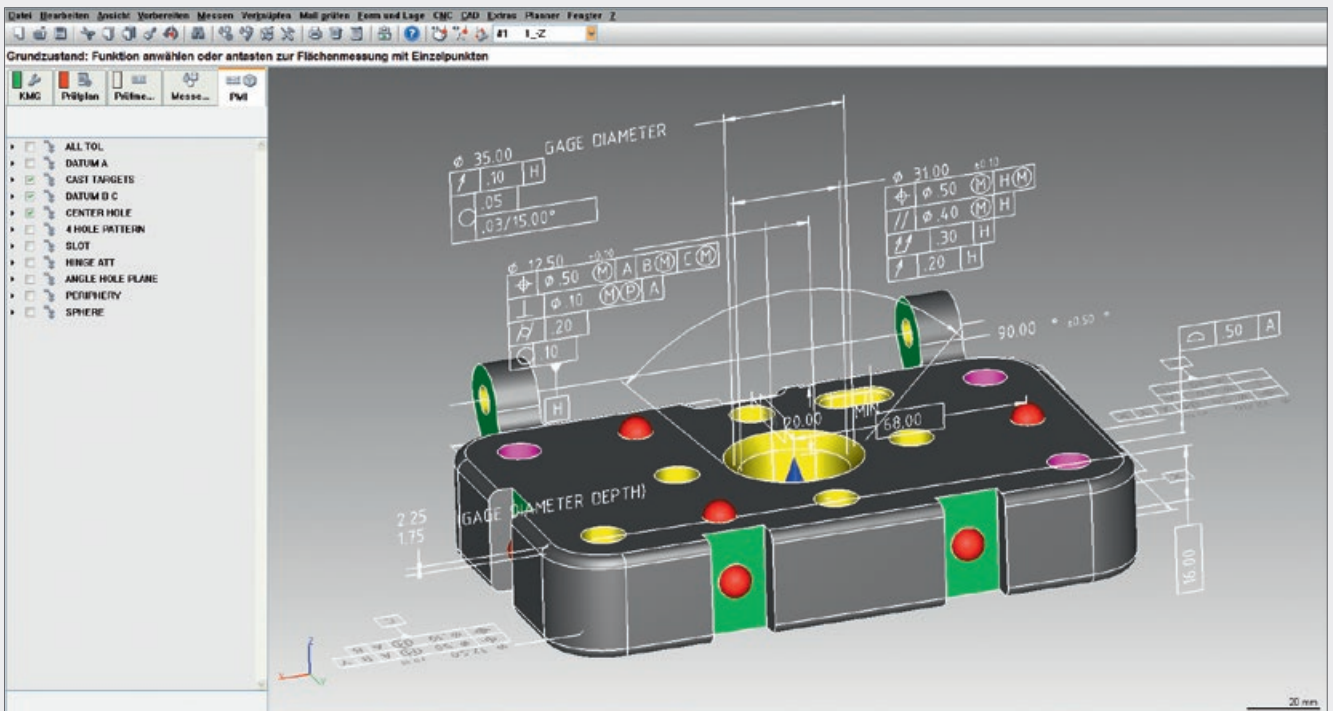

ZEISS CALYPSO imports CAD data including stipulated tolerances (PMI)



CAD import

CAD import options

■ Licensing of CAD formats for import into ZEISS CALYPSO

Standard CAD formats can be directly imported into ZEISS CALYPSO and then used to generate measurement plans. Depending on your requirements, you can receive licenses for the following formats: IGES, VDA, STEP, DXF 2D geometry, ParaSolid, CATIA V4, CATIA V5, ProEngineer, Siemens NX, Inventor, Solid Works, JT Open. An export function is also included for many of these formats.



DMIS

DMIS import and DMIS export

■ Options for the DMIS import and DMIS export

The DMIS Import option can be used to import measuring programs into ZEISS CALYPSO in the programming language DMIS and convert them to ZEISS CALYPSO measurement plans. With the DMIS Export option, CALYPSO measurement plans can be exported and converted to DMIS files of the format DMIS 3.0 or UMESS. Both options operate on a DMIS post-processor that has been specially adapted to ZEISS CALYPSO.



qs-STAT

Export for qs-STAT

■ Export of ZEISS CALYPSO result files for the qs-STAT statistics program

qs-STAT converts measurement results from ZEISS CALYPSO for further analysis in the qs-STAT statistics program. For this purpose, the ZEISS CALYPSO result files are converted into Q-DAS description and value files. With qs-STAT, you can then statistically evaluate production processes, for example.

ZEISS CALYPSO Options

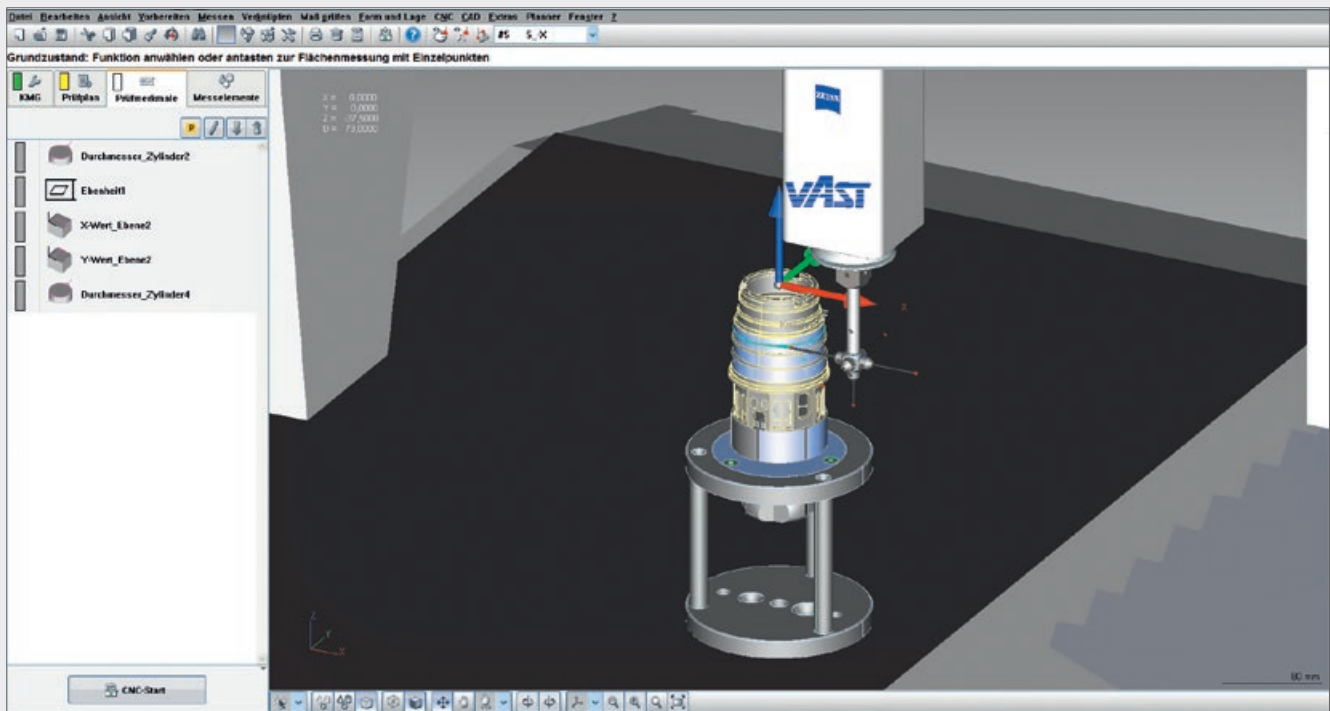

Simulation of a measuring run with the PLANNER and SIMULATION options



PLANNER

Generate measurement plans off-line

- Off-line version of ZEISS CALYPSO
- Programming without blocking the measuring machine

Use PLANNER to write measuring programs off-line. The benefit: your measuring machine is not blocked by PLANNER and can continue being used for additional measurements. PLANNER saves the finished measuring program, which can then be accessed and executed again with ZEISS CALYPSO at any time. In conjunction with the additional SIMULATION option, measuring runs can be simulated remotely.



FACS

Measure random samples

- Simplified user interface and customized automation solutions

FACS stands for Flexible Automation Control System. It makes it possible to integrate routine measuring applications into automated processes and is ideal, for example, for measuring random samples on a regular basis. FACS enables operators to start measuring runs via a simplified user interface at the push of a button. ZEISS CALYPSO operates unnoticed in the background – operating errors are therefore avoided. ZEISS customizes the system on the basis of three standard solutions.



BASIC AUTOMATION

- Standard automation solution
- Digital I/O or PROFIBUS interface

BASIC AUTOMATION makes it possible to integrate ZEISS measuring machines into partly or fully automated production processes. For example, a ZEISS measuring machine can be incorporated in a robot cell. The measurement plan is selected and the measurement started via the higher-level system without any additional manual entries. Here ZEISS CALYPSO works in the background.

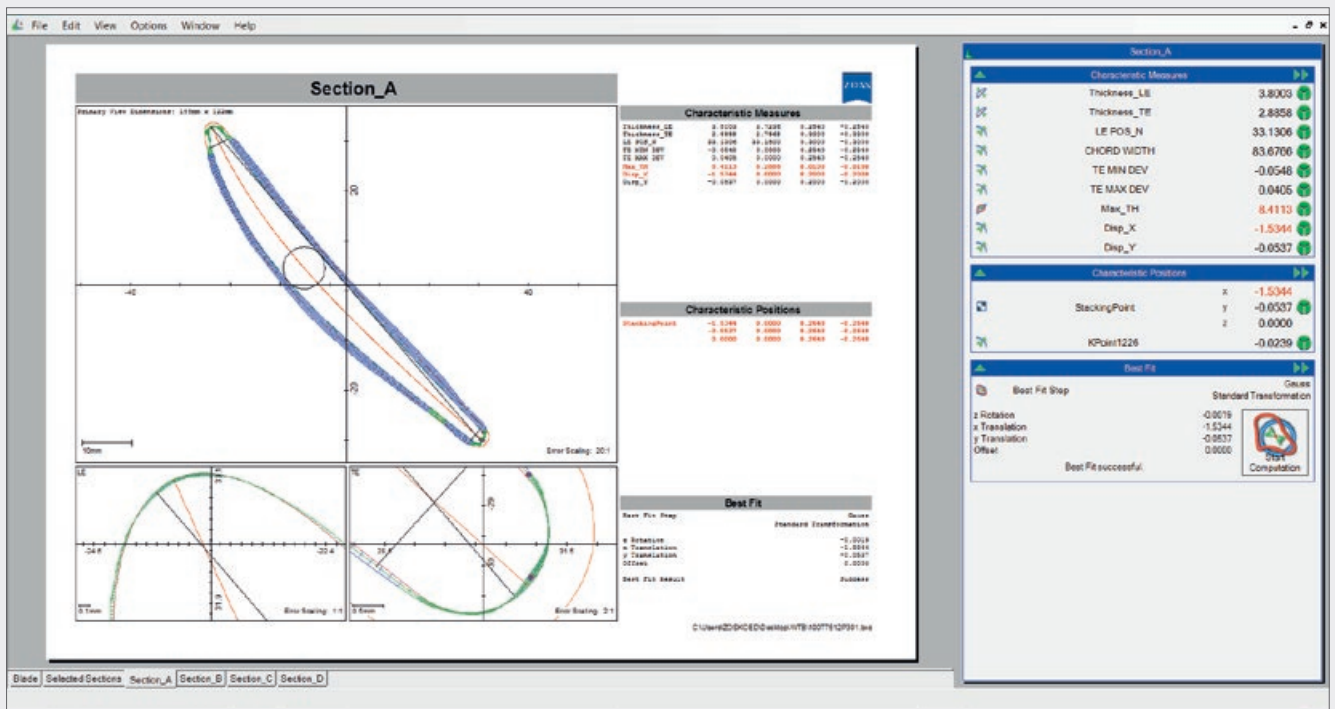

Analysis of a turbine blade with BLADE PRO



PRESET

Erosion electrodes

- External presetting of erosion electrodes to shorten setup times
- Graphic user guidance

With the PRESET erosion module you can measure offset and rotation when exchanging erosion electrodes in a matter of minutes. PRESET offers a collection of standard measurement plans. The graphic user guidance helps you configure the measuring run. CNC extensions are available for square and round basic geometries.



PTI

Polygon clamping devices

- Standardized measurement of workpiece holders with polygon taper interface

Manufacturers of PTI adapters use the PTI option to steer their milling, turning and grinding processes. Customers can use the same software in their incoming inspection and therefore receive comparable results. PTI supports the user in all work steps – from calibration of the stylus systems and the selection of the measuring programs to the adjustment of process-related grinding allowances.



BLADE PRO

Turbine blades

- Enormous range of blade section parameters
- Patented algorithm for improved evaluation on leading and trailing edges

BLADE PRO determines an enormous range of parameters for the analysis of turbine blades. The required specific analysis methods are featured in the software. Through the separation of length and form errors a patented algorithm improves the evaluation of leading and trailing edges. The neutral XML interface also permits usage with non-ZEISS metrology software.

ZEISS CALYPSO Options

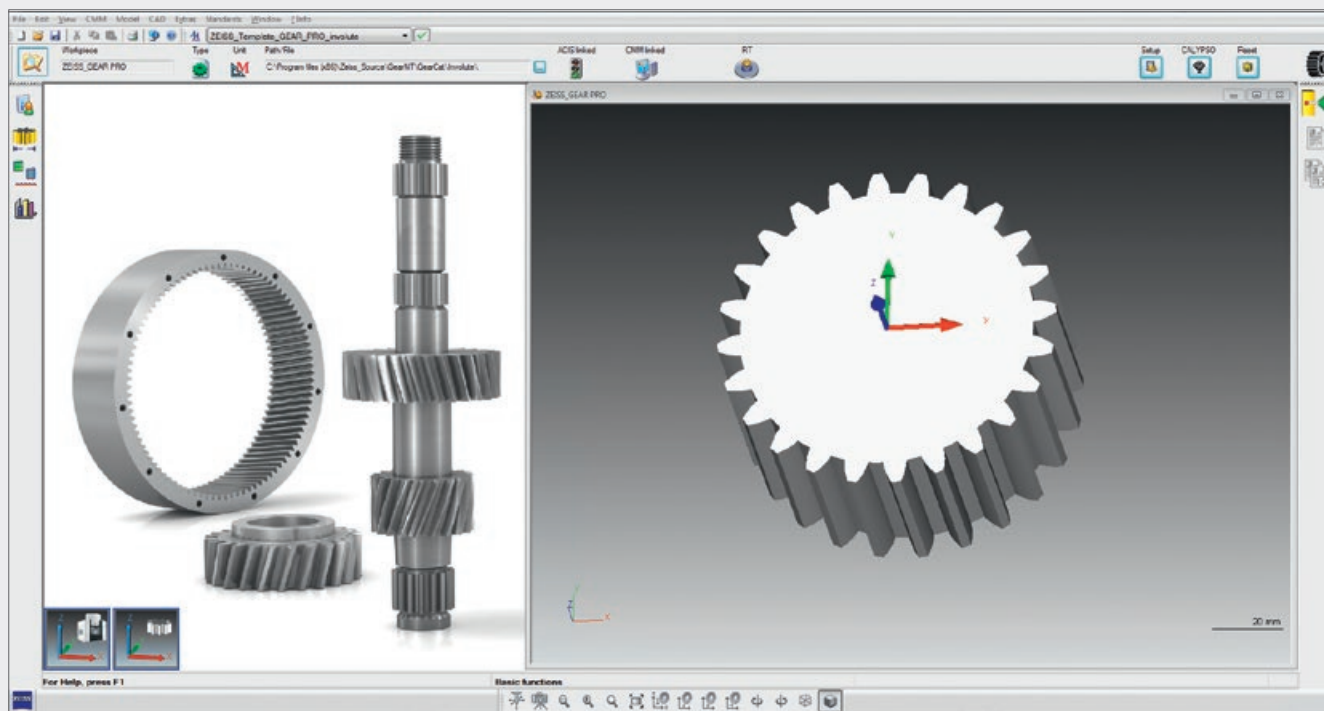

Specialist for spur gears: GEAR PRO involute

GE

GEAR PRO

Gear metrology

Highlights

- Graphic-supported input
- CAD simulation of the measuring run
- Active and passive sensors
- Measurement with and without rotary table
- Standard-compliant, automatic evaluation
- Application-oriented reporting

Gear metrology on the CMM

Narrow tolerances are the only way for gear wheels to transfer forces quietly with almost no loss. The precision of production and gear tooth measurement must go hand in hand. The GEAR PRO option for ZEISS CALYPSO enables gear tooth measurements on coordinate measuring machines. The analytical 3D gear model and the graphic-supported input windows make measuring with GEAR PRO highly effective.

Visual inspection

Through the interaction of the software core and the graphic user interface, GEAR PRO generates a CAD model of the gear from the definition of the geometry. The graphic display of the CAD model allows you to quickly and visually check the input values. A standard measurement can already be started on the basis of the geometry definition.

User guidance

Graphic input windows and systematic guidance with each step simplify the adjustment of the measuring run to the respective measuring task. A few mouse clicks are all that is needed to define, for example, evaluation and measuring ranges, with the aid of windows and graphic visualization.

Variable evaluation

GEAR PRO offers numerous possibilities for evaluating gear features. This depends on the previously specified scope. Measurements can also be subsequently evaluated with changed parameters.



Evaluation of a worm profile with GEAR PRO worm

Five packages are available for typical fields of application:

Cylindrical gears – GEAR PRO involute

- Involute splines
- Conically corrected gears
- Beveloids
- Linear profiles
- GDE interface

Bevel gears – GEAR PRO bevel

- Spiral gear or straight bevel gear
- Variations such as pinions, ring gears and dies

The nominal data can be generated in typical industry formats or can be imported from a CAD model. Alternatively, the master gear method can be used.

Worm gears – GEAR PRO worm

Suitable for typical worm profiles such as ZI, ZA, ZN and ZK.

Rotors (screw compressors) – GEAR PRO rotor

GEAR PRO rotor supports male, female and straight rotors. The nominal data can be generated from a profile transverse section or a CAD model.

Gear hobs – GEAR PRO hob

- Single and multi-gear gear hobs can be measured for the manufacture of involute gears.
- Gear hobs with reversing plate technology
- Gear hobs with tangential cutting geometry

Specialist for freeform surfaces

ZEISS CALIGO

A large number of measuring points is needed for testing freeform surfaces. The software architecture of ZEISS CALIGO is specially designed for this purpose. Intelligent functions and a logically structured interface make measuring with ZEISS CALIGO easy and fast. The software provides efficient tools for analysis measurements, serial measurements, simulations and reporting.



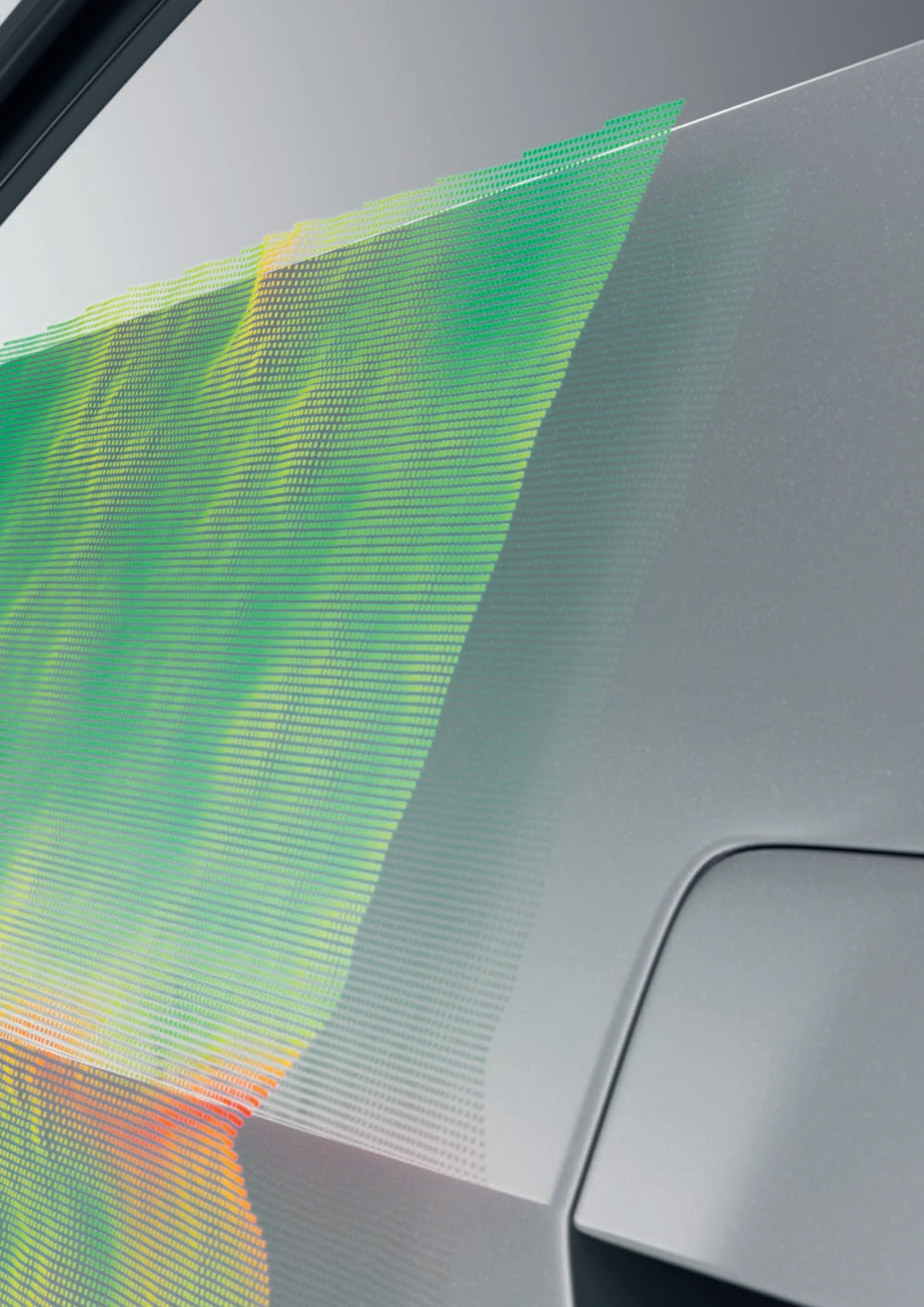



ZEISS CALIGO

Universal metrology software
focused on
freeform surfaces

Highlights

- Efficient tools for testing freeform surfaces and standard geometries in car body construction
- Ease of use
- Powerful software architecture for processing large amounts of data
- Efficient change management
- Integrated simulation functions for off-line programming
- Collision protection through automatic travel paths
- Path-in/Path-out
- Includes ZEISS PiWeb reporting

Efficient tools for users in car body construction

By focusing on the measurement of freeform surfaces, ZEISS CALIGO is primarily intended for users in car body construction. They receive a total solution that enables them to measure and evaluate standard geometries in addition to freeform surfaces. ZEISS CALIGO is easy to use, has a short learning curve, and offers powerful data processing tools and many functions that simplify quality assurance.

Tailor-made for large amounts of data

With its modern, modular system architecture, ZEISS CALIGO is designed to meet future challenges. Optimal usage of the system resources available enables fast processing and provision of the extensive data generated during the measurement of freeform surfaces.

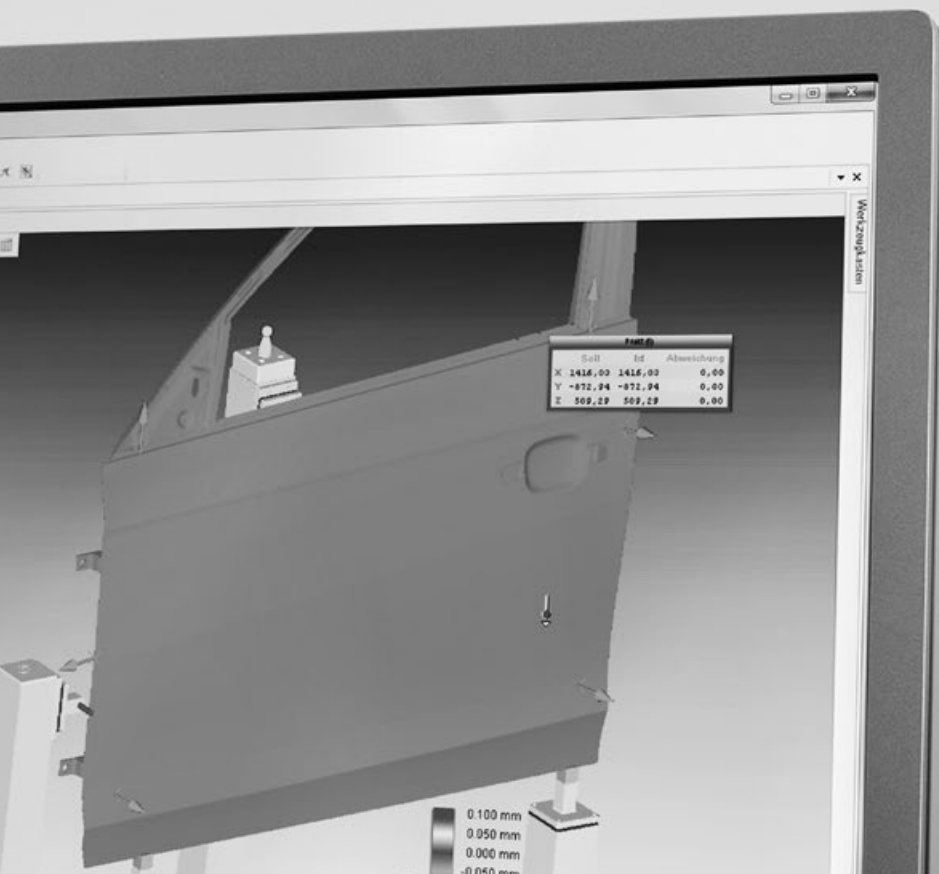

The time-saving way to manage changes

ZEISS CALIGO offers efficient change management. Feature lists can be imported and directly saved as measurement plans. The synchronization function compares changed feature lists to the current measurement plan. Every modification is shown to users, who can then decide if they wish to accept the change by mouse click or make additional modifications.

Simulation of the measurement run

The simulation functions in ZEISS CALIGO provide you with many ways of analyzing measuring programs off-line. The measuring run is displayed as an animation in the CAD window. Functions such as collision control, travel path track and collision ball will help you to optimize programming and to troubleshoot. Various horizontal arm measuring machines and duplex

systems can be completely simulated in ZEISS CALIGO. The ZEISS EagleEye optical sensor has also been taken into consideration. This allows you to set up a run with the ZEISS EagleEye off-line.

Automatic travel paths

ZEISS CALIGO can generate travel paths automatically around a protective cover to prevent collisions with the workpiece and automatically finds the path from feature to feature. Furthermore, the new "Path in/Path out" navigation function is integrated into ZEISS CALIGO. This enables you to program a safe path into and back out of an interior space. Certain features from an extensive measurement plan or new features can be programmed quickly and measured reliably.

ZEISS PiWeb reporting included

ZEISS PiWeb reporting is included with ZEISS CALYPSO on delivery. Use the report templates or generate your own reports or templates. The option ZEISS PiWeb reporting plus allows you to expand the integrated statistics function from 10 to 1,000 measurements. The packages ZEISS PiWeb sbs and ZEISS PiWeb enterprise (see pages 22–23) provide you with a complete system for web-based quality data management.

Perfect control of all important data. Everywhere.

ZEISS PiWeb

ZEISS PiWeb is a scalable IT solution for quality data management. With the database-supported versions ZEISS PiWeb sbs and ZEISS PiWeb enterprise, you can organize the information flow resulting from Industry 4.0 and therefore enhance the quality of your products and productivity. Entry into modern data management is easy: ZEISS PiWeb reporting is already contained in ZEISS CALYPSO and ZEISS CALIGO.



Pi

ZEISS PiWeb

Quality data management

Highlights

ZEISS PiWeb network solutions

- Scalable quality data management
- Manufacturer-independent and flexible: supports many data types such as DMO, DFQ, CSV, TXT, PCN and many more
- Easy generation of even complex report templates
- Simple and fast knowledge sharing through intuitive reports in real time
- Interactive access to CAD displays, detailed information and additional data with a single mouse click
- Extensive statistical evaluations
- Secure internet access via https connection
- Modern, high-performance database technology

Single workstation solutions:

ZEISS PiWeb reporting, ZEISS PiWeb reporting plus

ZEISS PiWeb is available in four configurations. ZEISS PiWeb reporting already offers professional reporting and displays the value progression of the last ten measurements. ZEISS PiWeb reporting plus allows statistical evaluations of up to 1,000 measurements and measuring system analyses.

Networked solutions:

ZEISS PiWeb sbs, ZEISS PiWeb enterprise

For collecting data from several measuring machines and other data sources, ZEISS offers the database solutions ZEISS PiWeb sbs and ZEISS PiWeb enterprise. ZEISS PiWeb sbs has been designed for quality data management in measuring rooms and small companies. ZEISS PiWeb enterprise is focused on



large companies and is also suitable for multi-site and global data collection.

All required data in one report.

Access anywhere and everywhere.

The ZEISS PiWeb network solutions save quality data and other product-related data on a central server. Via a secure internet connection, this data can be accessed from any location and displayed in the form of reports. This means that quality data from a large number of measuring machines from different manufacturers are available on a global scale – and in real time.

Generate report templates the simple way

Generating report templates in ZEISS PiWeb is no problem. You work intuitively by drag & drop, guided by dialog menus. Numerous standard templates are available

and can be modified if necessary. Or generate your own templates with quality indicators, interactively adjustable CAD views, form plots, false color displays, histograms, box plots, Cp-Cpk diagrams, etc.

Dynamic reports

No reports published via ZEISS PiWeb are unalterable. All data displayed remains linked to the database. You have access to interactive reports via the PiWeb Monitor viewer. Here, for example, you can rotate and enlarge a CAD view. You can access detailed information by clicking on a measuring point. You can filter out data or even select other data sources.

Statistical analysis

ZEISS PiWeb offers all the tools you need for statistical analyses, e.g. different distributions and functions for outlier management and for measuring system

analyses. QDAS data can be imported and exported.

Recognize quality factors

Process data from production can also be processed by ZEISS PiWeb. This makes it possible to analyze the causal relationship between process parameters and quality characteristics. This knowledge will help you, for example, to prevent production errors and increase tool service life.

Software for optical 3D sensor systems

ZEISS colin3D

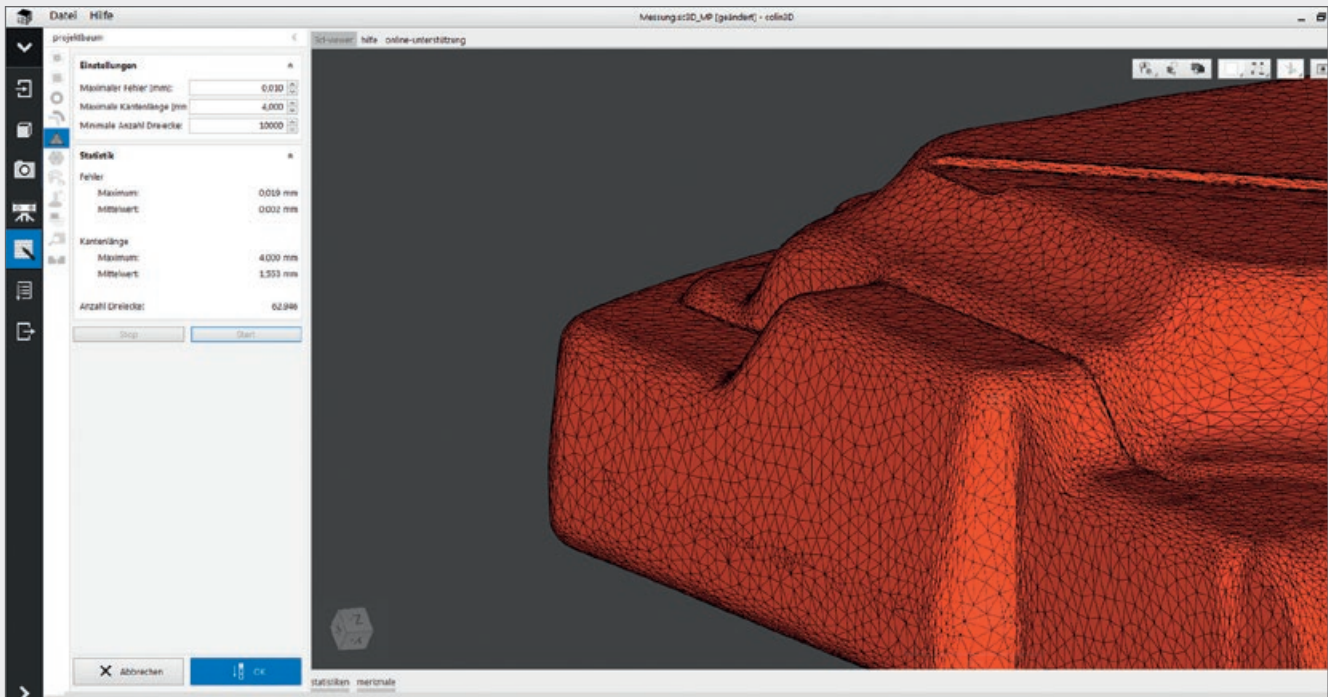

Quick triangular network computation using high-quality data reduction



ZEISS colin3D

Optical 3D capture
and 3D analysis

Highlights

- Perfectly matched to optical 3D sensor systems from ZEISS Optotechnik
- Fast triangular network generation
- Surface comparison with report function
- Intuitive network processing
- Documentation of calibration
- Monitoring of system accuracy
- Automatically high-quality measured data through intelligent quality criteria

Innovative functionality

The ZEISS colin3D software platform is designed to ideally complement the COMET, COMET Photogrammetry and T-SCAN sensor systems. The program independently identifies the ideal strategies for merging individual images (matching) and guides you to the ideal result using a completely redesigned, project-oriented user interface. Thanks to the CAD integration, you receive continual feedback about the component surface areas that still need to be captured.

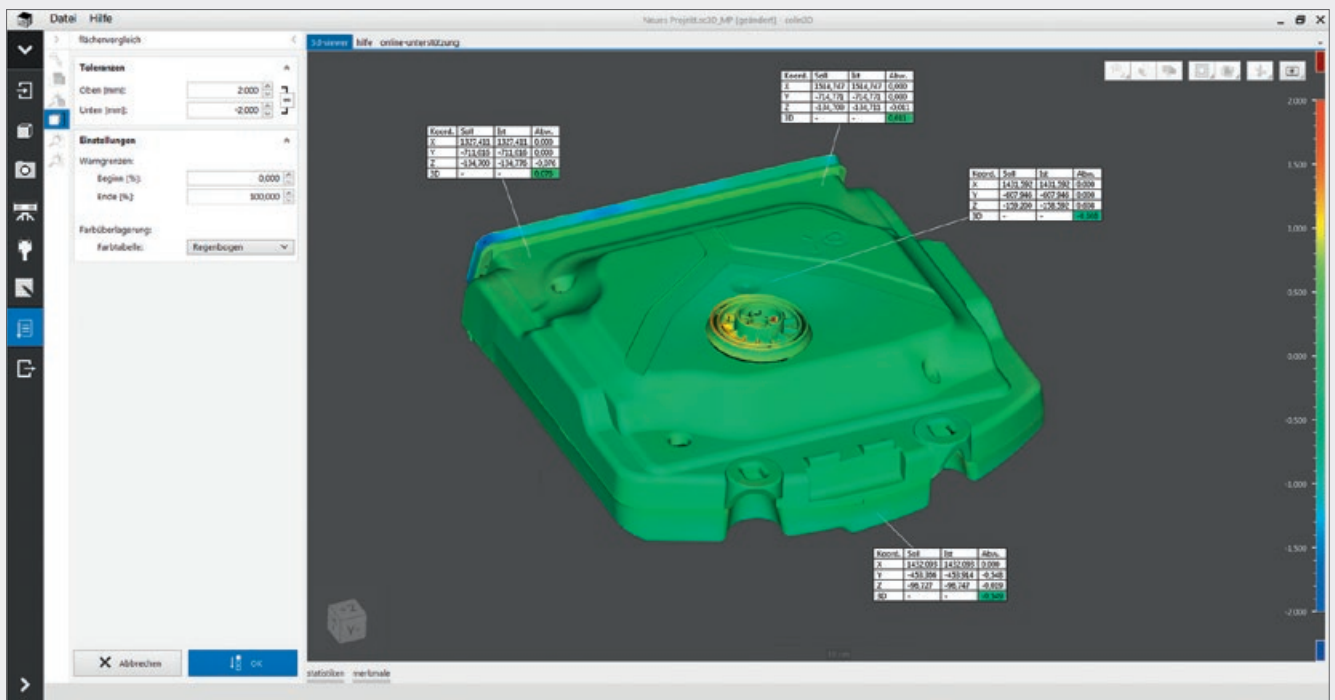

Simple off-color comparison

Maximum performance

Based on years of programming experience with 64-bit operating systems and the corresponding hardware such as graphics cards and multi-processor systems, the new algorithms of ZEISS colin3D achieve maximum performance and data quality.

Optimal user support

To quickly and efficiently position the T-SCAN system from ZEISS, the measurement field and scanner can be optionally displayed in ZEISS colin3D, making it easier to determine the ideal tracker position. Measuring programs for applications using the rotary tables COMETrotary and COMETdual rotary can be easily generated and executed. All individual measurements in a measurement sequence are subjected to quality checks and automatically repeated if necessary.

Data analysis functions

For quality assurance applications, the scan data can be compared on the surface of a CAD model using a simple best fit alignment. ZEISS colin3D contains a simple false color display with a color gradient and fixed values. To more precisely analyze deviations, users can place the flyers on the surface individually as required. Reports for documenting the measurement results can be easily and quickly generated and managed.

Maximum ease of use

Thanks to the extremely user-friendly, reduced user interface, little training is required and the software is easy to work with. Adapted to the workflow, the standardized menu structure is logically and incrementally built and only contains the setting options that are of relevance to the application.

Back to the CAD model

ZEISS REVERSE ENGINEERING

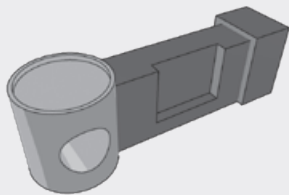

1. Product data set



2. Actual data: product

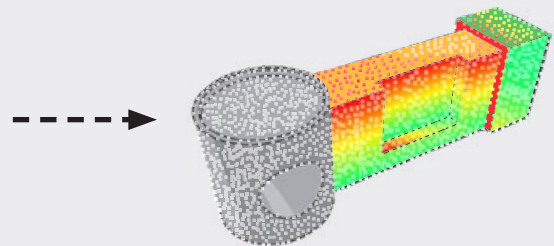

3. Analysis: plan-actual comparison

RE

ZEISS REVERSE ENGINEERING

Reverse engineering and tool correction

Highlights

- Highly precise reverse engineering
- User-friendly operation, modern optics
- Simple processing of point clouds
- Automated standard geometry recognition
- CAD quality analysis
- Basic CAD functions
- Special functions for tool correction

CAD data from point clouds

Reverse engineering is an important step to extract the design data from a finished component. The part must first be scanned, e.g. with an optical sensor or with a computer tomograph.

High result quality

From the resulting point clouds, ZEISS Reverse Engineering generates surface descriptions which can then be processed in the CAD system. As a result, complex

surfaces can be described in their entirety with small data quantities. Standard geometries are not only described as an approximation, but also through exact geometric elements. In addition to the precise description of the model, the algorithms smooth the surfaces to an extent that the transitions are as tangentially constant and curvature-constant as possible – a must for optimal milling paths.

Processing point clouds

Prior to reverse engineering, the input data must usually be structured and edited. ZEISS Reverse Engineering offers exactly the right tools for this task.

- Rectangle, polygon and Lasso selection (modes: add, delete, either-or)
- Efficient management of selected point quantities
- Deletion of outliers and digitizing errors

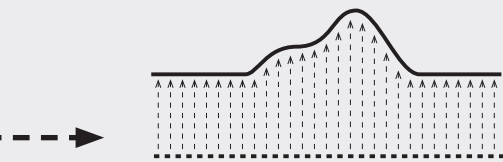

4. Errors are transferred to your tool

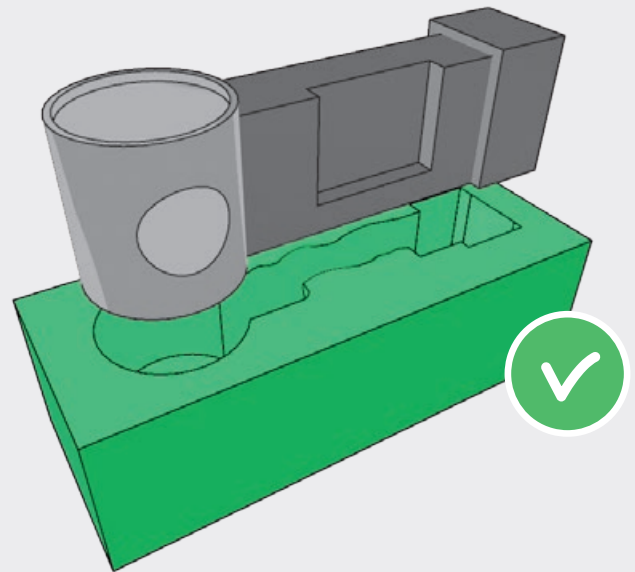

5. Corrected tool

Automated work steps

Intelligent algorithms simplify working with the software and improve the quality of the resulting CAD model.

- Curvature estimator for point cloud segmentation
- Feature extraction for automated standard geometry recognition
- Routines for point cloud thinning
- Automated tools for multi-step trimming of the computed surfaces

Quality analysis and CAD functions

In addition to reverse engineering, the software offers important functions to analyze the quality of the computed models. Basic CAD functionalities such as blending, extending and binding area also provided. These are needed, for example, to build complex components from the ground up.

Special functions for tool correction

The tool correction is an excellent feature of ZEISS Reverse Engineering. You generate ready-for-use CAD data for correcting injection molding tools. ZEISS Reverse Engineering determines not only the deviations of a scanned component from the nominal data, but also subsequently calculates the appropriately corrected tool form. A single correction loop is often sufficient to finish machining a tool, allowing the correction process to be cut by weeks. A particular benefit of the ZEISS Reverse Engineering software is the ability to stipulate continuity conditions. These can be easily modified to fit the particular component shape and the shrinkage behavior of the material used.

Automated to the Measuring Program

ZEISS iDA

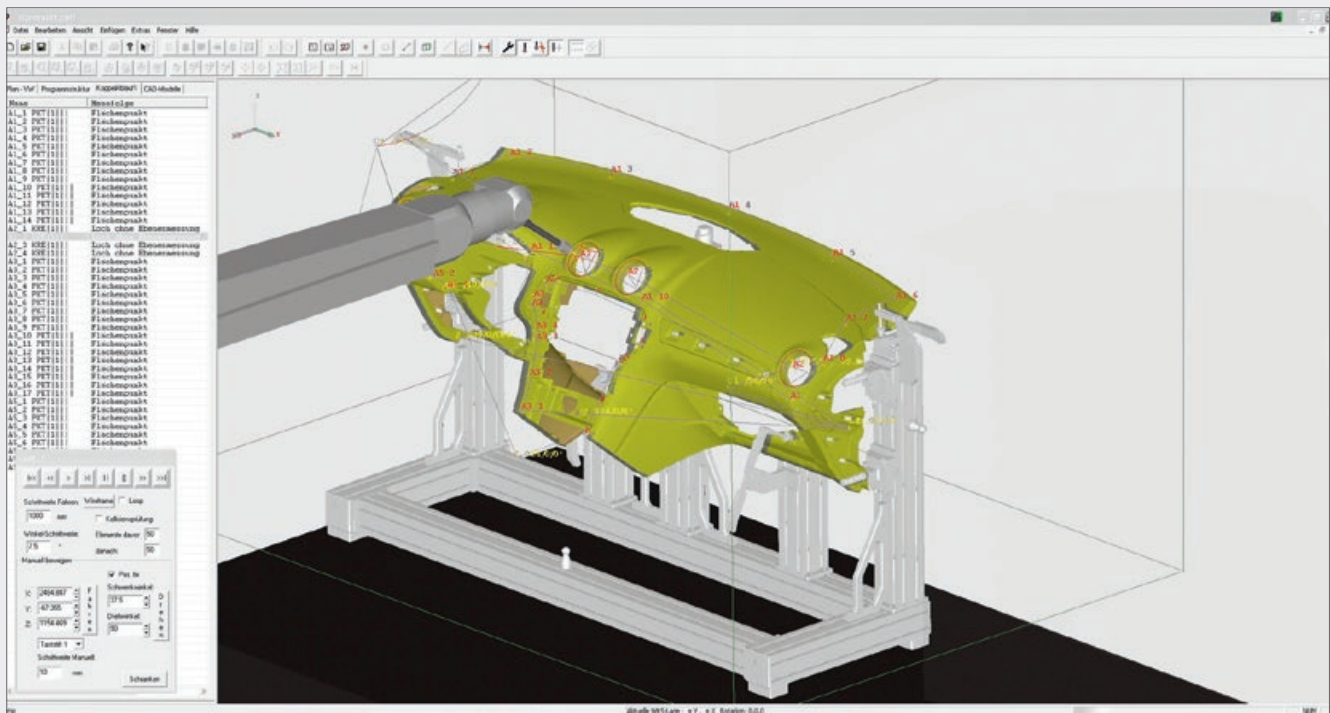

ZEISS iDA

Off-line programming system for car body construction

Highlights

- Manufacturer-neutral programs in DMIS format
- High degree of automation
- Measurement plan formats of all leading carmakers
- Machine simulation
- Collision check
- Change management
- I++ DME interface

Automated programming

ZEISS iDA provides the metrologist with efficient tools for measurement planning and off-line programming in car body construction. Thanks to a large number of automated functions ZEISS iDA accelerates the conversion of measuring plans into measuring programs. These are relayed in the standardized DMIS format to the appropriate measuring machines, regardless of the manufacturer. The abbreviation iDA stands for Integrated DMISGen Application. iDA accommodates the measuring plan formats of all leading carmakers.

Features

With ZEISS iDA, measurement planning and programming are performed using a complete 3D representation of the measuring machine, fixture and part. To simplify programming, the software uses standardized measuring principles which are, however, flexible thanks to parameterization.

The complete measuring run is simulated virtually and checked for possible collisions. The automated change management functionality of ZEISS iDA assists the metrologist in integrating changes to the measurement plans reliably and quickly in the corresponding measuring programs.

Manage coordinate measuring technology via the intranet

ZEISS Master Control Center

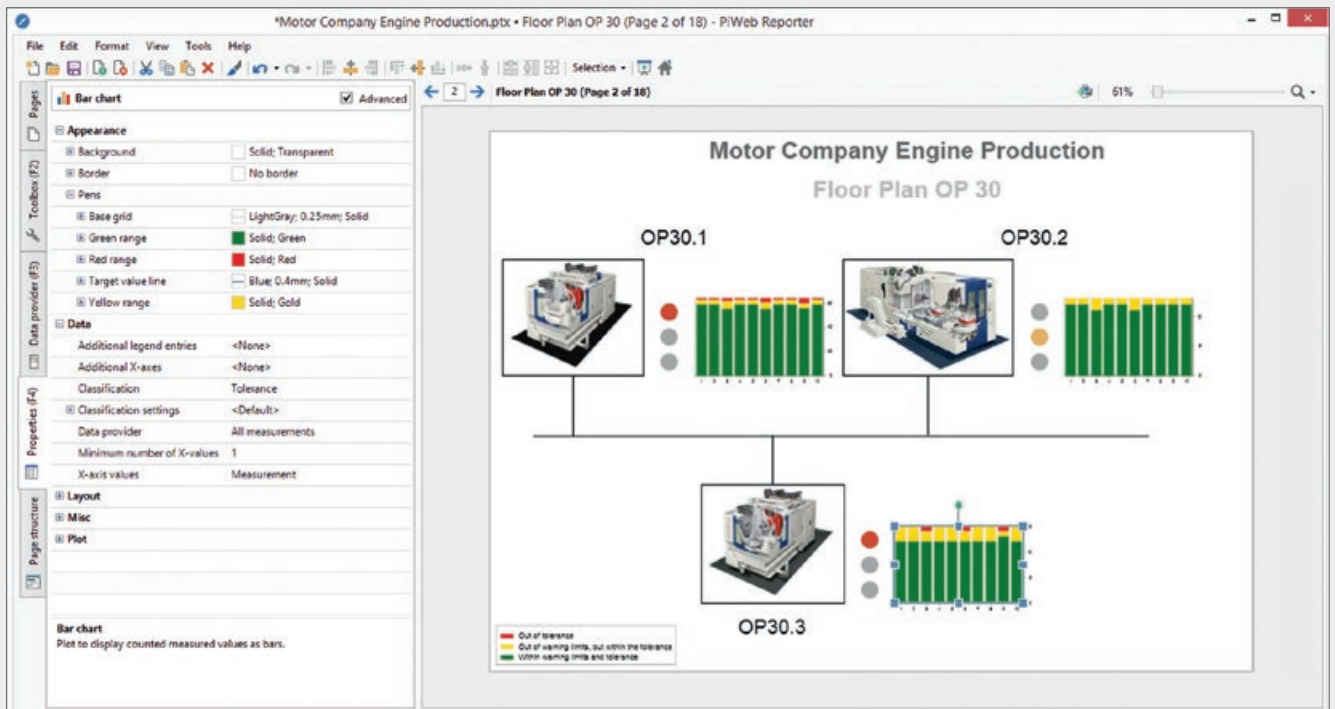

ZEISS Master Control Center

Metrology and knowledge management

Highlights

- Central organization of measuring machines, software, reports and other documents
- Master Control Center for coordinate metrology
- Web-based user and access management
- Clear structure
- Ease of use
- Index-based full text search
- Modular design

Central knowledge platform for coordinate metrology

The ZEISS Master Control Center organizes measuring machines, measuring software, reports and documents of different formats on the corporate intranet. This is a management system and knowledge portal specially optimized for coordinate metrology. It ensures that centrally organized metrology information is available where it is needed. Its technical basis is a secure server on the corporate intranet with web-based user and access management.

Easy operation and administration

Due to its intuitive operation and easy management, users of the ZEISS Master Control Center do not require any training or special courses. The content is clearly structured and easy to understand. It can be customized at any time and supplemented with new forums, albums and files. The index-based full text search enables users to access the data they need

quickly and easily. The search function scans all types of documents: PDF, Word, Excel, PowerPoint, Text and others.

Modular design

Because the ZEISS Master Control Center has a modular structure, investment costs can be easily calculated. Implementation can be performed step by step to meet your specific requirements.

Carl Zeiss
Industrielle Messtechnik GmbH
73446 Oberkochen/Germany
Sales: +49 7364 20-6336
Service: +49 7364 20-6337
Fax: +49 7364 20-3870
info.metrology.de@zeiss.com
www.zeiss.de/imt

Carl Zeiss
Industrial Metrology, LLC
6250 Sycamore Lane North
Maple Grove, MN 55369/USA
Phone: +1 763 744-2400
Fax: +1 763 533-0219
info.metrology.us@zeiss.com
www.zeiss.com/metrology