

## **User Manual**

### **Interroll Drum motor**

**i-Series**

**S-Series**

**S/A-Series**

**D-Series**

**Manufacturer**

Interroll Trommelmotoren GmbH  
Opelstr. 3  
41836 Hueckelhoven/Baal  
Germany  
Phone: +49 2433 44 610  
[www.interroll.com](http://www.interroll.com)

**Contents**

We strive for the information presented to be correct, up to date and complete. We have carefully worked out the contents of this document. However, we assume no liability for the information. We expressly deny any liability for damages or consequential damages that are connected in any form with the use of this document. We reserve the right to change the documented products and product information at any time.

**Copyright / intellectual property right**

Texts, images, graphics and the like as well as their arrangement are protected by copyright and other protection laws. Reproduction, modification, transfer or publication of any part or the entire content of the document in any form is prohibited. This document is intended exclusively for information purposes and for intended use and does not authorize replicating the respective products. All signs contained in this document (registered trademarks, such as logos and business designations) are the property of Interroll Trommelmotoren GmbH or third parties and may not be used, copied or distributed without prior written consent.

## Table of Contents

<b>Introduction.....</b>	<b>7</b>
Information about the manual.....	7
Contents.....	7
The instructions are part of the product.....	7
Warning notices in this document.....	7
Symbols.....	8
<b>Safety .....</b>	<b>9</b>
State of the art.....	9
Intended use .....	9
Unintended use .....	9
Personnel qualification .....	10
Operators .....	10
Service personnel.....	10
Electricians.....	10
Dangers.....	10
Bodily injury .....	10
Electricity.....	10
Oil.....	10
Rotating parts.....	10
Hot motor parts.....	11
Working environment .....	11
Faults during operation .....	11
Maintenance.....	11
Accidental motor start.....	11
Interfaces to other devices.....	11
<b>General technical information.....</b>	<b>12</b>
Product description .....	12
Options .....	12
Technical data .....	13
Product identification.....	13
Thermal protection.....	14
Standard design: Temperature limiter, automatically switching back.....	15
Optional version: PTC (positive temperature coefficient).....	15
Use of 50-Hz motors on 60-Hz supply system.....	16
Effect of using a motor with 50 Hz on a 60-Hz supply system.....	16
Effect of using a motor with 50-Hz on a 60-Hz supply system with 15/20 % higher voltage .....	17
<b>i-series product information.....</b>	<b>18</b>
Type plate of i-series drum motor .....	18
Electrical data of i-series .....	20
80i 3-phase.....	20
113i 3-phase.....	21
138i 3-phase.....	23



## Interroll Drum motor series i, S, S/A, D

### Table of Contents

165i and 217i* 3-phase .....	25
217i 3-phase .....	27
Dimensions of i-series drum motor .....	29
Connection diagrams for the i-series .....	30
Cable connections .....	30
Connections in the terminal box .....	33
<b>S-series product information .....</b>	<b>38</b>
Type plate of S-series drum motor .....	38
Electrical data of S-series .....	40
80S 1-phase .....	40
80S 3-phase .....	40
113S 1-phase .....	41
113S 3-phase .....	41
Dimensions of S-series drum motor .....	43
Connection diagrams for the S-series .....	45
Cable connections .....	45
Connections in the terminal box .....	47
<b>S/A-series product information .....</b>	<b>48</b>
Type plate of S/A-series drum motor .....	48
Electrical data of S/A-series .....	49
113S/A 1-phase .....	49
113S/A 3-phase .....	49
Dimensions of S/A-series drum motor .....	50
Connection diagrams for the S/A-series .....	51
Cable connections .....	51
Connections in the terminal box .....	53
<b>D-series product information .....</b>	<b>54</b>
Type plate of D-series drum motor .....	54
Electrical data of D-series .....	55
Dimensions of D-series drum motor .....	57
Connection diagrams for the D-series .....	57
Cable connections .....	58
Encoder connection .....	58
<b>Options and accessories .....</b>	<b>60</b>
Electromagnetic brake for the i-series .....	60
Brake rectifiers for i-series .....	62
Brake rectifier connections .....	62
Brake rectifier dimensions .....	64
Asynchronous drum motors with frequency inverters .....	66
Torque dependent on input frequency .....	66
Frequency inverter parameters .....	66
Encoder type BMB-6202 & 6205 SKF for the i-series .....	68
Technical data .....	68
Connections .....	69
Best connection option .....	70

## Interroll Drum motor series i, S, S/A, D

### Table of Contents

Encoder type RM44-RLS for the i and D-series .....	71
Technical data .....	71
Connections .....	72
Signal connection .....	72
Resolver type RE-15-1-LTN.....	73
Connections .....	73
Technical data .....	73
Impedance.....	74
<b>Transport and storage .....</b>	<b>75</b>
Transport.....	75
Storage .....	75
<b>Assembly and installation .....</b>	<b>77</b>
Warning notices concerning the installation .....	77
Installing the drum motor .....	77
Positioning the drum motor.....	77
Installing the motor with mounting brackets.....	78
Installation considering hygienic aspects .....	80
Belt assembly .....	80
Belt width / tube length.....	80
Belt adjustment.....	80
Tensioning the belt .....	81
Belt tension .....	82
Belt elongation.....	82
Measuring the belt elongation .....	83
Calculating the belt elongation .....	83
Drum coating.....	84
Sprockets .....	84
Warning notices concerning the electrical installation .....	85
Electrical connection of the drum motor.....	85
Connecting the drum motor – with a cable.....	85
Connecting the drum motor – with a terminal box.....	85
Single-phase motor .....	86
External motor protection.....	86
Integrated thermal protection .....	86
Frequency inverter .....	86
Backstop.....	87
Electromagnetic brake.....	87
<b>Initial startup and operation.....</b>	<b>89</b>
Initial startup .....	89
Checks before the initial startup .....	89
Operation.....	90
Checks before every startup.....	90
Procedure in case of accident or fault.....	90
<b>Maintenance and cleaning.....</b>	<b>91</b>
Warning notices concerning maintenance and cleaning.....	91



## Interroll Drum motor series i, S, S/A, D

---

### Table of Contents

Preparation for maintenance and cleaning by hand .....	91
Maintenance .....	91
Checking the drum motor .....	91
Relubricating the drum motor .....	91
Maintaining drum motors with optional, relubricating IP66 seals .....	91
Oil change at drum motor .....	92
Oil types .....	93
Oil quantities for the i-series in liters (standard installation) .....	94
Oil quantities for the i-series (vertical installation) .....	95
Cleaning .....	95
Cleaning the drum motor with pressure washer .....	95
Hygienic cleaning .....	96
<b>Troubleshooting .....</b>	<b>97</b>
Troubleshooting .....	97
<b>Decommissioning and disposal .....</b>	<b>107</b>
Shutdown .....	107
Disposal .....	107
<b>Appendix .....</b>	<b>108</b>
List of abbreviations .....	108
Electrical data .....	108
Connection diagrams .....	109
Color coding .....	110
Installation declaration .....	111

## Introduction

### Information about the manual

The following drum motor types are described in this instruction manual:

- 80S, 113S
- 113S/A
- 80i, 113i, 138i, 165i, 217i
- 80D, 113D

### Contents

This instruction manual contains important notes and information about the various operating phases of the drum motor:

The instruction manual describes the drum motor as it is delivered by Interroll.

In addition to this instruction manual, special contractual agreements and technical documents apply to special versions.

### The instructions are part of the product

- ▶ For trouble-free, safe operation and warranty claims, read the instructions first and follow the notices.
- ▶ Keep the instructions close to the drum motor.
- ▶ Pass the instructions on to any subsequent operator or owner.
- ▶ **NOTICE! The manufacturer does not accept any liability for faults or defects due to non-observance of these instructions.**
- ▶ If you still have questions after reading the instructions, please contact Interroll customer service. Contact persons near you can be found on the Internet under [www.interroll.com/contact](http://www.interroll.com/contact).

### Warning notices in this document

The warning notices refer to risks which may arise while using the drum motor. They are available at four danger levels with the following signal words:

Signal word	Meaning
DANGER	Identifies a danger with high risk that leads to death or serious injury if it is not avoided.
WARNING	Identifies a danger with medium risk that can lead to death or serious injury if it is not avoided.
CAUTION	Identifies a danger with low risk that can lead to minor or medium injury if it is not avoided.
NOTICE	Identifies a danger that leads to property damages.



## Interroll Drum motor series i, S, S/A, D

---

### Introduction

### Symbols



This symbol marks useful and important information.

#### Requirement:

- This symbol represents a prerequisite to be met prior to assembly and maintenance work.
- ▶ This symbol marks the steps to be carried out.



## Safety

### State of the art

The conveyor is designed according to the state of the art and is reliable in operation, once distributed. However, risks may still arise.



Disregarding the notices in this manual may lead to serious injury.

- ▶ Carefully read the manual and follow its content.

### Intended use

The drum motor is intended for use in industrial environments, supermarkets and airports and is used for transporting general cargo, such as parts, cardboard boxes or boxes, as well as transporting bulk material such as granular material, powder and other fluid materials. The drum motor must be integrated into a conveyor module or conveyor system. Any other use is considered inappropriate.

Use of the drum motor is only allowed in the areas described in the product information chapter.

Any modifications that affect the safety of the product are not permitted.

The drum motor may only be operated within the defined operating limits.

### Unintended use

The drum motor must not be used for transporting people.

The drum motor is not intended for use under impact or shock loads.

The drum motor is not designed to be used under water. Such a use leads to personal or fatal injuries from electrocution as well as the penetration of water, resulting in a short circuit or motor damage.

The drum motor may not be used as a drive for cranes or lifting devices or for the corresponding hoist ropes, cables or chains.

Use of the drum motor for anything other than the intended purpose is subject to approval by Interroll.

Unless otherwise stated in writing and/or specified in a quote, Interroll and its dealers shall assume no liability for product damage or failure which result from failure to observe these specification and restrictions (see the chapter "Electrical data" of the respective series).

## Interroll Drum motor series i, S, S/A, D

### Safety

#### Personnel qualification

Unqualified personnel cannot recognize risks and, as a result, is subject to greater dangers.

- ▶ Authorize only qualified personnel with the activities described in these installation and operating instructions.
- ▶ The operating company must ensure that the personnel follows locally applicable regulations and rules during their work with regard to safety and dangers.

The following target groups are addressed in these installation and operating instructions:

<b>Operators</b>	Operators have been instructed in operating and cleaning the drum motor and follow the safety guidelines.
<b>Service personnel</b>	The service personnel features a technical training or has undergone training by the manufacturer and performs the maintenance and repair tasks.
<b>Electricians</b>	Persons working on electrical installations must have the pertinent technical training.

#### Dangers



The following list informs you about the various types of danger or damage that may occur while working with the drum motor.

<b>Bodily injury</b>	<ul style="list-style-type: none"><li>▶ Maintenance or repair work must only be executed by authorized and qualified persons in accordance with the applicable regulations.</li><li>▶ Before turning on the drum motor, ensure that no unauthorized persons are near the conveyor.</li></ul>
<b>Electricity</b>	<ul style="list-style-type: none"><li>▶ Only perform installation and maintenance work after you have switched off the power. Ensure that the drum motor cannot be turned on accidentally.</li></ul>
<b>Oil</b>	<ul style="list-style-type: none"><li>▶ Do not ingest the oil. In general, the oil used is relatively non-toxic, but it can still contain hazardous substances. Ingestion can lead to nausea, vomiting and/or diarrhea. Generally, medical care is not required, unless large quantities have been ingested. Nevertheless, a physician should be consulted.</li><li>▶ Avoid skin and eye contact. Prolonged or repeated skin contact without proper cleaning can clog the pores of the skin and lead to skin problems such as oil acne and folliculitis.</li><li>▶ Wipe up spilled oil as quickly as possible to avoid slippery surfaces. Ensure that oil does not reach the environment. Properly dispose of dirty rags or cleaning materials to avoid self-ignition and fires.</li><li>▶ Extinguish oil fires with foam, spraying water or water mist, dry chemical powder or carbon dioxide. Do not extinguish with water jet. Wear suitable protective clothing, incl. breathing mask.</li><li>▶ Observe the corresponding certificates at <a href="http://www.interroll.com">www.interroll.com</a>.</li></ul>
<b>Rotating parts</b>	<ul style="list-style-type: none"><li>▶ Do not reach into areas between drum motor and conveyor belts or roller chains.</li><li>▶ Tie long hair together.</li><li>▶ Never wear loose clothing.</li></ul>

## Interroll Drum motor series i, S, S/A, D

---

### Safety

- Hot motor parts**
  - ▶ Never wear jewelery, such as necklaces or bracelets.
  - ▶ Do not touch the surface of the drum motor. It can result in burns, even under regular operating temperature.
  - ▶ Install corresponding warnings on the conveyor.
- Working environment**
  - ▶ Do not use the drum motor in explosive atmospheres.
  - ▶ Remove equipment or material which is not required from the workspace.
  - ▶ Wear safety shoes.
  - ▶ Clearly specify and monitor the way materials are placed on the conveyor.
- Faults during operation**
  - ▶ Regularly check the drum motor for visible damage.
  - ▶ In case of fumes, unusual noise or blocked or damaged materials, stop the drum motor at once and ensure that the RollerDrive cannot be started accidentally.
  - ▶ Contact qualified personnel immediately to find the source of the fault.
  - ▶ During operation, do not step on the drum motor or the conveyor/the system in which it is installed.
- Maintenance**
  - ▶ Check the product regularly for visible damages, unusual noise and firm seating of fittings, screws and nuts. An additional maintenance is not required.
  - ▶ Do not open the drum motor.
- Accidental motor start**
  - ▶ Take care during installation and maintenance work or in the event of a drum motor fault: The drum motor could start up unintentionally.

### Interfaces to other devices

Hazards may occur while integrating the drum motor into a complete system. These are not part of this manual and have to be analyzed during the design, installation and startup of the complete system.

- ▶ After assembling the drum motor in a conveyor module, check the whole system for a new potential dangerous spot before switching on the conveyor.
- ▶ Additional constructive measures may be required.

### General technical information

#### Product description

The drum motor is a completely enclosed electrical drive roller. It replaces external components such as motors and gears, which require frequent maintenance.

The drum motor can be used in environments with high coarse and fine dust exposure as well as exposed to water jets and spraying water and is resistant to most of the aggressive ambient conditions. In aggressive environments and environments with salt water, only stainless steel motors should be used. Thanks to protection classification IP66 or IP69k and its stainless steel design (upon request), the drum motor is also suitable for use in the food processing industry and pharmaceutical industry as well as for applications with high hygienic demands. The drum motor can be used without as well as with a drum coating to increase the friction between drum motor and conveyor belt or with profile coating for the drive of form-fit driven belts.

The drum motors of series S, S/A and i are driven by an asynchronous three-phase induction motor. It is available in different power stages and for most of the international supply voltages.

The drum motors of the D-series are driven by a synchronous motor and must be connected to a suitable drive control unit. For additional information about the drive control unit, see the respective manual.

The drum motor contains oil as lubricant and coolant which dissipates the heat via the drum and the conveyor belt.

If an asynchronous drum motor without belt or with a form-fit driven belt is used, a special design is available to ensure cooling.

#### Options

**Integrated thermal overload protection:** A thermal cut motor protection switch integrated in the winding head protects against overheating. The switch trips if the motor overheats. However, it has to be connected to a suitable external control device that interrupts the current supply to the motor in case of overheating (see "*Thermal protection*", page 14).

**Integrated electromagnetic brake:** The integrated electromagnetic brake can hold loads. It acts directly on the rotor shaft of the drum motor and is controlled by a rectifier. The holding force of each drum motor with brake has to be calculated first and does not always correspond to the belt pull of the motor. The electromagnetic brake is available for all drum motors of the i-series (see "*Electromagnetic brake for the i-series*", page 60).

**Mechanical backstop:** The mechanical backstop attached to the rotor shaft and, for 80i, in the cover, can be used for ascending conveyors. It prevents the belt from running in reverse direction in case of a power failure. The mechanical backstop is available for all drum motors, except 113s and the D-series.

**Encoder:** The signal of the encoder can be used for position determination and for controlling the speed and rotational direction (see "*Options and accessories*", page 60).

## Interroll Drum motor series i, S, S/A, D

### General technical information

### Technical data

Protection class	IP65 (S/A-series) IP66 (i and S-series) IP69k (D-series)
Ambient temperature range for standard applications <sup>1)</sup>	+5 °C to +40 °C
Ambient temperature range for low-temperature applications <sup>1)</sup>	-25 °C to +15 °C
Ambient temperature range for reduced drum motors <sup>1)</sup>	+5 °C to +25 °C
Cycle times	max. 3 starts/stops per minute <sup>2)</sup>
Ramp times	i-series: ≥ 0.5 s S-series: ≥ 1 s D-series: ≤ 0.5 s
Installation altitude above sea level	max. 1000 m

<sup>1)</sup> Depending on the ambient temperature, different types of oil are required (see "Oil types", page 93). For ambient temperatures below +1 °C, Interroll recommends a standstill heater and special cables.

<sup>2)</sup> For start/stop applications, the motor shifts have to be designed completely backlash-free. If this requirement is met, higher cycle times with more than 3 starts/stops per minute are possible. Interroll strongly recommends using frequency inverters (FI) with set run-up or run-down ramps or special designs. This is used to reduce the starting torques, e.g. to prevent gear box damage. If you have questions, please contact Interroll.

### Product identification

The information given below is required in order to identify a drum motor. The values for a specific drum motor can be entered in the last column.

Information	Possible value	Own value
Type plate of drum motor	Motor type Speed in m/s Serial number Tube length in mm Number of poles Power in kW	
Drum diameter (tube diameter)	e.g. 112.3 mm drum ends 113.3 mm drum center	
Cover material	e.g. rubber, thickness, profile	

## Interroll Drum motor series i, S, S/A, D

---

### General technical information

#### Thermal protection

Under normal operating conditions, the thermal circuit breaker integrated in the stator winding is closed. When the motor limit temperature is reached (overheating), the switch opens at a preset temperature to prevent damage to the motor.

---

#### **WARNING**

**The thermal circuit breaker is automatically reset after the motor has cooled off.**

Inadvertent start-up of the motor

- ▶ Connect the thermal circuit breaker in series with a suitable relay or contactor so that the current supply to the motor is safely interrupted when the switch trips.
  - ▶ Ensure that the motor can be switched on again after overheating only with a confirmation button.
  - ▶ After the switch has tripped, wait until the motor has cooled off, and ensure prior to switch-on that there is no danger to persons.
-

## Interroll Drum motor series i, S, S/A, D

### General technical information

**Standard design:**  
Temperature limiter,  
automatically switching  
back

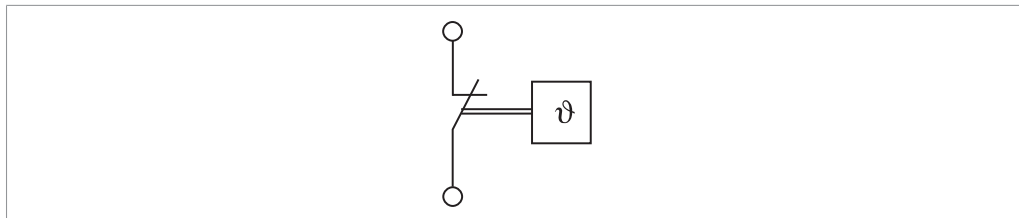

#### Service life: 10,000 cycles

AC	$\cos \varphi = 1$	2.5 A	250 V AC
	$\cos \varphi = 0.6$	1.6 A	250 V AC
DC		1.6 A	24 V DC
		1.25 A	48 V DC

#### Service life: 2000 cycles

AC	$\cos \varphi = 1$	6.3 A	250 V AC
Reset temperature		40 K $\pm$ 15 K	
Resistance		< 50 m $\Omega$	
Contact bounce time		< 1 ms	

**Optional version: PTC**  
(positive temperature  
coefficient)

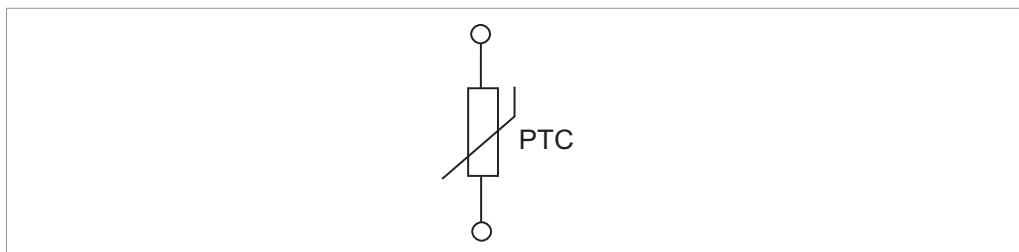

Maximum operating voltage		W	25
Thermal time constant		s	< 10
Resistance at switching temperature	+ 15 K	$\Omega$	1330 ... 4000
	+ 5 K	$\Omega$	550 ... 1330
		$\Omega$	550
	- 5 K	$\Omega$	250 ... 550
	- 20 K	$\Omega$	< 250



In particular, if the motor does not have an internal thermal winding protection, a suitable external thermal control relay/contactors must be connected upstream.

A thermal winding protection does not replace the overcurrent protection. In addition, every motor must be connected to a suitable overcurrent protection which is set to the rated motor current.

## Interroll Drum motor series i, S, S/A, D

### General technical information

#### Use of 50-Hz motors on 60-Hz supply system

This option is not available for the D-series.

#### Effect of using a motor with 50 Hz on a 60-Hz supply system

**Rated motor voltage:** 230/400 V - 3 ph - 50 Hz

**System voltage:** 230/400 V - 3 ph - 60 Hz

If a 50-Hz motor is connected to a 60-Hz supply system, the frequency increases and, as a result, the speed by 20 %. Since the torque decreases accordingly, the motor output remains constant. The voltage-dependent parameters change in the speed range under field control at 60 Hz according to the following table:

System voltage = rated motor voltage			
Power	P	kW	100 %
Rated speed	$n_n$	1/min	120 %
Rated torque	$M_n$	Nm	83.3 %
Starting torque	$M_A$	Nm	64 %
Pull-up torque	$M_S$	Nm	64 %
Pull-out torque	$M_K$	Nm	64 %
Rated current	$I_N$	A	95 %
Starting current	$I_A$	A	80 %
Power factor	$\cos \varphi$		106 %
Efficiency	$\eta$		99.5 %



## Interroll Drum motor series i, S, S/A, D

### General technical information

**Effect of using a motor with 50-Hz on a 60-Hz supply system with 15/20 % higher voltage**

**Rated motor voltage:** 230/400 V - 3 ph - 50 Hz

**System voltage:** 276/480 V - 3 ph - 60 Hz - 2 & 4 poles (motor voltage + 20 %)

**System voltage:** 265/460 V - 3 ph - 60 Hz - 6, 8 & 12 poles (motor voltage + 15 %)

If a 50-Hz motor with a 20% higher voltage is operated on a 60-Hz supply system, frequency and speed increase by 20 %. But except for minor deviations, the rated motor parameters remain constant (V/f constant).



If the supply voltage is increased by 15 % compared to the motor voltage, the actual motor output decreases to 92 % of the original motor output.

In this operating mode, the motor should have an output reserve of at least 20%.

Supply voltage = 1.2 x rated motor voltage (for 2 and 4 number of poles)

Power	P	kW	100 %
Rated speed	$n_n$	1/min	120 %
Rated torque	$M_n$	Nm	100 %
Starting torque	$M_A$	Nm	100 %
Pull-up torque	$M_S$	Nm	100 %
Pull-out torque	$M_K$	Nm	100 %
Rated current	$I_N$	A	102 %
Starting current	$I_A$	A	100 %
Power factor	$\cos \varphi$		100 %
Efficiency	$\eta$		98 %

## i-series product information

### Type plate of i-series drum motor

The information on the type plate of the drum motor is intended for its identification. This is the only way for the drum motor to be used properly.

For drum motors of the i-series, there are different types of type plates:

- Half-circle type plate on the end housing of the drum motor (glued or lasered)
- Rectangular type plate on the terminal box (if available)
- Rectangular type plates with rounded corners on the individual components with special information about the product features

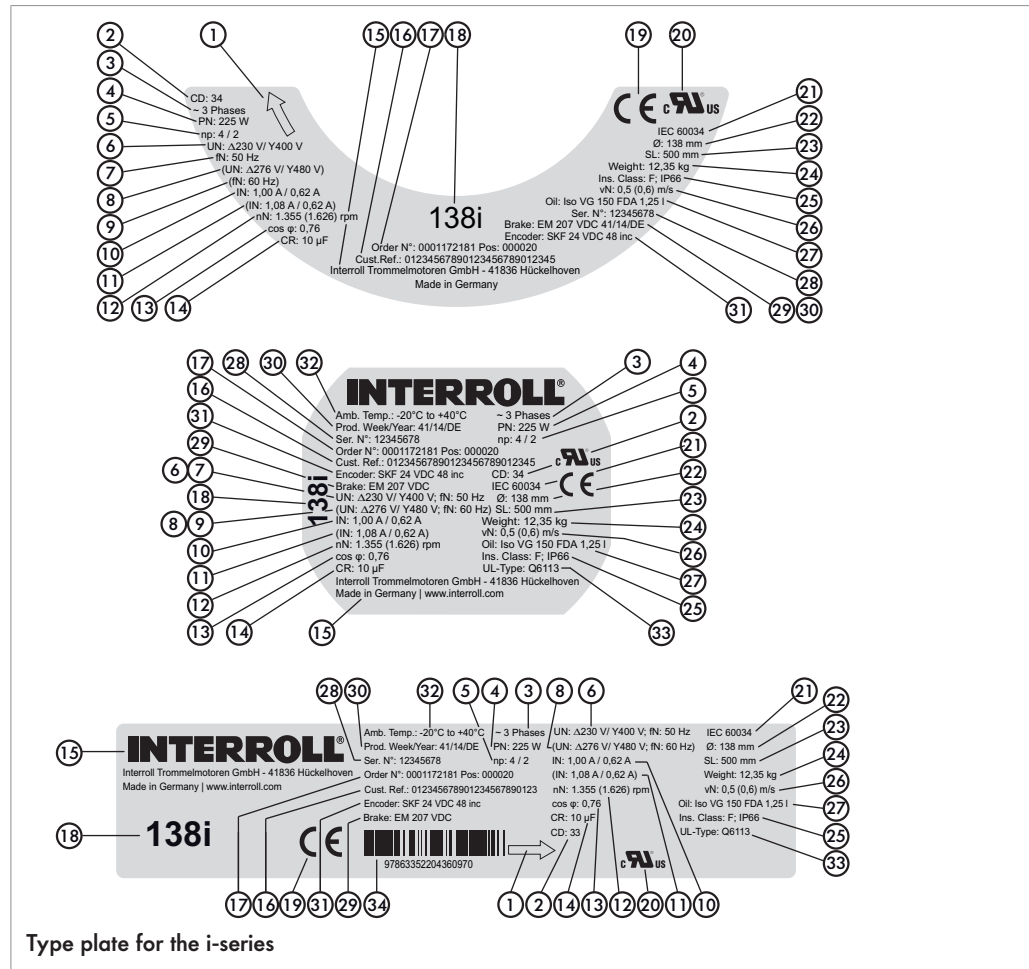

- |   |                           |    |                          |
|---|---------------------------|----|--------------------------|
| 1 | Direction of travel       | 18 | Type                     |
| 2 | Connection diagram number | 19 | CE mark                  |
| 3 | Number of phases          | 20 | UL mark                  |
| 4 | Rated power               | 21 | Standard for drum motors |
| 5 | Number of poles           | 22 | Max. diameter of tube    |

## Interroll Drum motor series i, S, S/A, D

---

### i-series product information

6	Rated voltage	23	Roller or tube length
7	Rated frequency	24	Weight
8	(rated voltage) <sup>1)</sup>	25	Insulation class and IP rating
9	(rated frequency) <sup>1)</sup>	26	Circumferential speed of tube
10	Rated current	27	Oil type
11	(rated current) <sup>1)</sup>	28	Serial number
12	Rated speed of rotor <sup>1)</sup>	29	Brake data
13	Power factor	30	Date of manufacture (week/year/country)
14	Run capacitor	31	Encoder data
15	Manufacturer / manufacturing location	32	Permissible ambient temperature
16	Customer part number	33	Type of UL standard
17	Part number	34	EAN code

<sup>1)</sup> The value depends on the voltage used. All values in parentheses refer to the rated voltage in parentheses.

## Interroll Drum motor series i, S, S/A, D

### i-series product information

#### Electrical data of i-series

Abbreviations see "List of abbreviations", page 108

#### 80i 3-phase

$P_N$	$n_p$	$n_N$	$f_N$	$U_N$	$I_N$	$\cos\varphi$	$\eta$	$J_R$	$I_s/I_N$	$M_s/M_N$	$M_B/M_N$	$M_p/M_N$	$M_N$	$R_M$	$U_{SH}$ delta	$U_{SH\ star}$	$C_r$
kW		min <sup>-1</sup>	Hz	W	A			kgcm <sup>2</sup>					Nm	Ω	V DC	V DC	μF
0.018	8	610	50	230	0.33	0.63	0.22	0.9	1.2	1	1.2	1	0.28	575	60	-	5
0.018	8	732	60	230	0.34	0.63	0.21	0.9	1.2	1.2	1.5	1	0.23	287.5	92	-	12
0.018	8	610	50	400	0.19	0.63	0.22	0.9	1.2	1	1.2	1	0.28	575	-	103	5
0.018	8	732	60	460	0.17	0.63	0.21	0.9	1.2	1.2	1.5	1	0.23	575	-	92	3
0.033	4	1384	50	230	0.3	0.62	0.45	0.4	1.7	2.73	2.74	2.48	0.23	286.5	27	-	4
0.033	4	1384	50	230	0.3	0.62	0.45	0.4	1.7	2.73	2.74	2.48	0.23	286.5	27	-	4
0.033	4	1384	50	400	0.17	0.62	0.45	0.4	1.7	2.73	2.74	2.48	0.23	286.5	-	45	4
0.033	4	1384	50	400	0.17	0.62	0.45	0.4	1.7	2.73	2.74	2.48	0.23	286.5	-	45	4
0.04	4	1384	50	230	0.37	0.68	0.41	0.4	1.9	1.8	2	1.8	0.28	240	30	-	5
0.04	4	1610	60	230	0.36	0.68	0.42	0.4	1.9	3.4	3.32	3	0.24	73.5	27	-	12
0.04	4	1384	50	400	0.21	0.68	0.41	0.4	1.9	1.8	2	1.8	0.28	240	-	51	5
0.04	4	1610	60	460	0.18	0.68	0.42	0.4	1.9	3.4	3.32	3	0.24	267.5	-	49	3
0.058	2	2750	50	230	0.26	0.78	0.71	0.4	2.4	2.15	2.26	1.9	0.201	183.5	19	-	-
0.058	2	2750	50	400	0.15	0.78	0.71	0.4	2.4	2.15	2.26	1.9	0.201	183.5	-	32	-
0.058	4	1310	50	230	0.39	0.68	0.54	0.6	2.4	2.31	2.31	2.15	0.423	106.4	14	-	-
0.058	4	1310	50	400	0.23	0.68	0.54	0.6	2.4	2.31	2.31	2.15	0.423	106.4	-	25	-
0.07	2	2778	50	230	0.38	0.82	0.56	0.4	2.6	1.9	2	1.9	0.24	190	30	-	-
0.07	2	3328	60	230	0.4	0.82	0.53	0.4	2.6	2.6	2.74	2.3	0.2	46	23	-	-
0.07	2	2778	50	400	0.22	0.82	0.56	0.4	2.6	1.9	2	1.9	0.24	190	-	51	-
0.07	2	3328	60	460	0.2	0.82	0.53	0.4	2.6	2.6	2.74	2.3	0.2	179.5	-	44	-
0.07	4	1288	50	230	0.48	0.68	0.53	0.6	1.4	1.66	1.75	1.66	0.52	156	25	-	7
0.07	4	1546	60	230	0.5	0.68	0.51	0.6	1.4	2.2	3.1	2.3	0.43	44	22	-	17
0.07	4	1288	50	400	0.28	0.68	0.53	0.6	1.4	1.66	1.75	1.66	0.52	156	-	45	7
0.07	4	1546	60	460	0.26	0.68	0.49	0.6	1.4	2.2	3.1	3	0.43	157.5	-	42	4
0.099	2	2727	50	230	0.45	0.78	0.71	0.6	2.4	2.31	2.31	2.15	0.347	106.4	19	-	-
0.099	2	2727	50	400	0.26	0.78	0.71	0.6	2.4	2.31	2.31	2.15	0.347	106.4	-	32	-
0.12	2	2778	50	230	0.59	0.78	0.65	0.6	2.6	2	2.1	2	0.41	89	20	-	-
0.12	2	3308	60	230	0.6	0.78	0.65	0.6	2.6	2.8	3	2.6	0.35	22.5	16	-	-
0.12	2	2778	50	400	0.34	0.78	0.65	0.6	2.6	2	2.1	2	0.41	89	-	35	-

## Interroll Drum motor series i, S, S/A, D

### i-series product information

$P_N$	$n_p$	$n_N$	$f_N$	$U_N$	$I_N$	$\cos\varphi$	$\eta$	$J_R$	$I_s/I_N$	$M_s/M_N$	$M_B/M_N$	$M_p/M_N$	$M_N$	$R_M$	$U_{SH}$ delta	$U_{SH\ star}$	$C_r$
kW		min <sup>-1</sup>	Hz	W	A			kgcm <sup>2</sup>					Nm	Ω	V DC	V DC	μF
0.12	2	3308	60	460	0.32	0.78	0.61	0.6	2.6	2.8	3	2.6	0.35	89	-	33	-

#### 113i 3-phase

$P_N$	$n_p$	$n_N$	$f_N$	$U_N$	$I_N$	$\cos\varphi$	$\eta$	$J_R$	$I_s/I_N$	$M_s/M_N$	$M_B/M_N$	$M_p/M_N$	$M_N$	$R_M$	$U_{SH}$ delta	$U_{SH\ star}$	$C_r$
kW		min <sup>-1</sup>	Hz	W	A			kgcm <sup>2</sup>					Nm	Ω	V DC	V DC	μF
0.035	12	353	50	230	0.71	0.6	0.21	3.3	2.4	1.1	1.46	1.1	0.95	208	44	-	10
0.035	12	353	50	400	0.41	0.6	0.21	3.3	2.4	1.1	1.46	1.1	0.95	208	-	77	10
0.058	12	353	50	230	0.91	0.6	0.26	5.7	1.9	1.07	1.16	0.91	1.569	144	39	-	-
0.058	12	353	50	400	0.53	0.6	0.26	5.7	1.9	1.07	1.16	0.91	1.569	144	-	69	-
0.066	8	680	50	230	0.55	0.6	0.5	3.3	2	1.57	1.82	1.74	0.927	190	31	-	-
0.066	8	680	50	400	0.32	0.6	0.5	3.3	2	1.57	1.82	1.74	0.927	190	-	55	-
0.07	12	353	50	230	1.07	0.6	0.27	5.7	2	1	1.3	1	1.89	128	41	-	15
0.07	12	415	60	230	1.08	0.6	0.21	5.7	1.92	1.2	1.29	1.1	1.4	128	62	-	11
0.07	12	353	50	400	0.62	0.6	0.27	5.7	2	1	1.3	1	1.89	128	-	71	15
0.07	12	415	60	460	0.62	0.6	0.21	5.7	1.92	1.2	1.29	1.1	1.4	128	-	143	11
0.08	8	680	50	230	0.69	0.6	0.48	3.3	2.2	1.4	1.6	1.4	1.12	164	34	-	10
0.08	8	680	50	400	0.4	0.6	0.48	3.3	2.2	1.4	1.6	1.4	1.12	164	-	59	10
0.083	6	865	50	230	0.66	0.63	0.5	3.3	1.9	1.82	1.74	1.49	0.916	126.4	26	-	-
0.083	6	865	50	400	0.38	0.63	0.5	3.3	1.9	1.82	1.74	1.49	0.916	126.4	-	45	-
0.1	6	865	50	230	0.8	0.66	0.47	3.3	2.1	1.8	2	1.8	1.1	111.4	29	-	11
0.1	6	865	50	400	0.46	0.66	0.47	3.3	2.1	1.8	2	1.8	1.1	111.4	-	51	11
0.1	6	1096	60	575	0.37	0.63	0.43	3.3	2.1	2.17	2.13	1.8	0.87	170	-	59	5
0.124	8	678	50	230	0.97	0.62	0.52	5.7	2	2.32	2.18	2.05	1.747	97	29	-	-
0.124	8	678	50	400	0.56	0.62	0.52	5.7	2	2.32	2.18	2.05	1.747	97	-	51	-
0.124	4	1360	50	230	0.65	0.7	0.67	2.1	2.9	1.57	1.57	1.32	0.871	86	20	-	-
0.124	4	1360	50	400	0.38	0.7	0.67	2.1	2.9	1.57	1.57	1.32	0.871	86	-	34	-
0.149	6	915	50	230	1.02	0.62	0.59	5.7	2.2	2.81	2.64	2.48	1.555	54.8	17	-	-
0.149	6	915	50	400	0.59	0.62	0.59	5.7	2.2	2.81	2.64	2.48	1.555	54.8	-	30	-
0.15	8	678	50	230	1.18	0.62	0.51	5.7	2.2	1.35	1.5	1.35	2.11	89	33	-	16
0.15	8	678	50	400	0.68	0.62	0.51	5.7	2.2	1.35	1.5	1.35	2.11	89	-	56	16
0.15	4	1350	50	230	0.94	0.71	0.56	2.1	3.2	1.85	2.15	1.85	1.06	71	24	-	13



## Interroll Drum motor series i, S, S/A, D

### i-series product information

$P_N$	$n_p$	$n_N$	$f_N$	$U_N$	$I_N$	$\cos\varphi$	$\eta$	$J_R$	$I_s/I_N$	$M_s/M_N$	$M_B/M_N$	$M_p/M_N$	$M_N$	$R_M$	$U_{SH}$ delta	$U_{SH\ star}$	$C_r$
kW		min <sup>-1</sup>	Hz	W	A			kgcm <sup>2</sup>					Nm	$\Omega$	V DC	V DC	$\mu F$
0.15	4	1632	60	575	0.38	0.7	0.57	2.1	3.2	1.9	1.9	1.6	0.88	114	-	45	5
0.15	4	1350	50	400	0.54	0.71	0.56	2.1	3.2	1.85	2.15	1.85	1.06	71	-	41	13
0.18	6	915	50	230	1.39	0.62	0.52	5.7	2.4	2.8	3	2.8	1.88	42.8	18	-	19
0.18	6	1098	60	230	1.36	0.76	0.44	5.7	3.2	3.4	3.2	3	1.57	43.5	34	-	12
0.18	6	915	50	400	0.8	0.62	0.52	5.7	2.4	2.8	3	2.8	1.88	42.8	-	32	19
0.18	6	1098	60	230	1.5	0.68	0.44	5.7	2.4	3.4	3.2	3	1.57	11.08	17	-	52
0.18	6	1098	60	460	0.75	0.68	0.44	5.7	3.2	3.4	3.2	3	1.57	43.5	-	33	13
0.18	6	1098	60	460	0.68	0.76	0.44	5.7	3.2	3.4	3.2	3	1.57	43.5	-	67	12
0.207	2	2850	50	230	1.1	0.71	0.66	1.4	4.2	2.48	2.56	2.31	0.69	36.1	14	-	-
0.207	2	2850	50	400	0.64	0.71	0.66	1.4	4.2	2.48	2.56	2.31	0.69	36.1	-	25	-
0.225	4	1308	50	230	1.56	0.71	0.51	2.1	2.7	2	2.3	2	1.64	40.6	22	-	21
0.225	4	1308	50	400	0.9	0.71	0.51	2.1	2.7	2	2.3	2	1.64	40.6	-	39	21
0.225	2	2821	50	230	1.21	0.71	0.65	1.4	4.6	3.5	3.7	3.5	0.76	29.6	13	-	-
0.225	2	3360	60	575	0.43	0.77	0.68	1.4	4.6	3	3.09	2.8	0.64	50	-	25	-
0.225	2	2821	50	400	0.7	0.71	0.65	1.4	4.6	3.5	3.7	3.5	0.76	29.6	-	22	-
0.248	4	1329	50	230	1.02	0.79	0.77	3.8	2.9	2.23	2.23	2.07	1.782	49.8	20	-	-
0.248	4	1329	50	400	0.59	0.79	0.77	3.8	2.9	2.23	2.23	2.07	1.782	49.8	-	35	-
0.3	4	1376	50	230	1.58	0.79	0.6	3.8	3.2	1.7	1.9	1.7	2.08	41	26	-	22
0.3	4	1652	60	230	1.6	0.78	0.6	3.8	3.2	2.7	2.7	2.55	1.73	40.95	38	-	14
0.3	4	1376	50	400	0.91	0.79	0.6	3.8	3.2	1.7	1.9	1.7	2.08	41	-	44	22
0.3	4	1652	60	230	1.55	0.78	0.62	3.8	3.2	2.7	2.65	2.5	1.73	10.55	19	-	54
0.3	4	1652	60	460	0.8	0.78	0.6	3.8	3.2	2.7	2.7	2.55	1.73	40.95	-	38	14
0.3	4	1652	60	460	0.8	0.78	0.6	3.8	3.2	2.7	2.7	2.55	1.73	40.95	-	77	14
0.3	4	1652	60	575	0.62	0.78	0.62	3.8	3.2	2.7	2.6	2.55	1.73	64	-	46	9
0.306	4	1376	50	230	1.43	0.78	0.68	3.8	2.9	2.23	2.23	2.07	2.124	41.5	23	-	-
0.306	4	1376	50	400	0.83	0.78	0.68	3.8	2.9	2.23	2.23	2.07	2.124	41.5	-	40	-
0.306	2	2880	50	230	1.41	0.79	0.68	2.4	4.2	2.48	2.56	2.31	1.015	20.5	11	-	-
0.306	2	2880	50	400	0.82	0.79	0.68	2.4	4.2	2.48	2.56	2.31	1.015	20.5	-	20	-
0.37	4	1301	50	230	1.91	0.79	0.62	3.8	3.2	2.4	2.3	2.2	2.72	26.4	20	-	26
0.37	4	1652	60	230	1.76	0.78	0.69	3.8	3.2	2.4	2.3	2.2	2.17	28.3	29	-	15
0.37	4	1301	50	400	1.1	0.79	0.62	3.8	3.2	2.4	2.3	2.2	2.72	26.4	-	34	26
0.37	4	1668	60	460	1.08	0.78	0.55	3.8	3.2	2.4	2.3	2.2	2.12	28.25	-	36	19
0.37	4	1652	60	460	0.87	0.78	0.69	3.8	3.2	2.4	2.3	2.2	2.14	28.25	-	29	15

## Interroll Drum motor series i, S, S/A, D

### i-series product information

$P_N$	$n_p$	$n_N$	$f_N$	$U_N$	$I_N$	$\cos\varphi$	$\eta$	$J_R$	$I_s/I_N$	$M_s/M_N$	$M_B/M_N$	$M_p/M_N$	$M_N$	$R_M$	$U_{SH}$ delta	$U_{SH\ star}$	$C_r$
kW		min <sup>-1</sup>	Hz	W	A			kgcm <sup>2</sup>					Nm	Ω	V DC	V DC	μF
0.37	4	1652	60	460	0.88	0.78	0.69	3.8	3.2	2.4	2.3	2.2	2.17	28.3	-	58	15
0.37	4	1668	60	575	0.77	0.78	0.62	3.8	3.2	2.4	2.3	2.2	2.12	45.65	-	41	11
0.37	2	2835	50	230	1.91	0.79	0.62	2.4	6.1	3.65	3.9	3.65	1.25	16.5	12	-	-
0.37	2	3402	60	230	1.39	0.79	0.74	2.4	6.1	4.1	4.07	3.55	1.04	16.75	14	-	-
0.37	2	2835	50	400	1.1	0.79	0.62	2.4	6.1	3.65	3.9	3.65	1.25	16.5	-	22	-
0.37	2	3402	60	230	1.6	0.79	0.74	2.4	6.1	4.1	4.07	3.55	1.04	4.15	8	-	-
0.37	2	3402	60	460	0.8	0.79	0.74	2.4	6.1	4.1	4.07	3.55	1.04	16.75	-	16	-
0.37	2	3402	60	460	0.8	0.79	0.74	2.4	6.1	4.1	4.07	3.55	1.04	16.75	-	32	-
0.37	2	3402	60	575	0.8	0.79	0.59	2.4	6.1	4.1	4.07	3.5	1.04	23.95	-	23	-
0.55	4	1690	60	230	2.73	0.64	0.62	4.9	3.9	2.42	2.45	2.42	3.11	17	15	-	30
0.55	4	1269	50	230	2.65	0.7	0.52	2.1	2.7	1.9	1.8	1.6	2.92	27.7	0	-	37
0.55	4	1380	50	230	3.36	0.68	0.6	4.9	3.5	2	2	2	3.81	16.4	19	-	47
0.55	4	1690	60	460	1.75	0.64	0.62	4.9	3.9	2.42	2.45	2.42	3.11	17	-	29	30
0.55	4	1269	50	400	1.53	0.7	0.52	2.1	2.7	1.9	1.8	1.6	2.92	27.7	-	45	37
0.55	4	1380	50	400	1.95	0.68	0.6	4.9	3.5	2	2	2	3.81	16.4	-	33	47
0.55	2	2679	50	230	2.42	0.8	0.69	1.4	4.6	3	3.1	2.8	1.9	19.5	19	-	-
0.55	2	2730	50	230	2.3	0.87	0.74	4.9	4.7	2.5	2.29	2.5	1.92	17	17	-	-
0.55	2	2679	50	400	1.4	0.8	0.69	1.4	4.6	3	3.1	2.8	1.9	19.5	-	33	-
0.55	2	2730	50	400	1.23	0.87	0.74	4.9	4.7	2.5	2.29	2.5	1.92	17	-	27	-

### 138i 3-phase

$P_N$	$n_p$	$n_N$	$f_N$	$U_N$	$I_N$	$\cos\varphi$	$\eta$	$J_R$	$I_s/I_N$	$M_s/M_N$	$M_B/M_N$	$M_p/M_N$	$M_N$	$R_M$	$U_{SH}$ delta	$U_{SH\ star}$	$C_r$
kW		min <sup>-1</sup>	Hz	W	A			kgcm <sup>2</sup>					Nm	Ω	V DC	V DC	μF
0.074	12	415	50	230	0.94	0.4	0.49	9.3	2.7	1.16	1.32	0.99	1.703	110	21	-	-
0.074	12	415	50	400	0.55	0.4	0.49	9.3	2.7	1.16	1.32	0.99	1.703	110	-	36	-
0.083	12	498	60	266	1.06	0.4	0.43	9.3	2.88	1.29	1.47	1.1	1.59	92	-	20	11
0.083	12	498	60	460	0.61	0.4	0.43	9.3	2.88	1.29	1.47	1.1	1.59	92	-	34	11
0.09	12	415	50	230	1.14	0.4	0.49	9.3	3	1.15	1.68	1.15	2.07	92	21	-	16
0.09	12	415	50	400	0.66	0.4	0.49	9.3	3	1.15	1.68	1.15	2.07	92	-	36	16
0.149	8	684	50	230	0.94	0.64	0.61	9.3	2.4	1.32	1.4	1.16	2.08	98	29	-	-
0.149	8	684	50	400	0.55	0.64	0.61	9.3	2.4	1.32	1.4	1.16	2.08	98	-	52	-



## Interroll Drum motor series i, S, S/A, D

### i-series product information

$P_N$	$n_p$	$n_N$	$f_N$	$U_N$	$I_N$	$\cos\varphi$	$\eta$	$J_R$	$I_s/I_N$	$M_s/M_N$	$M_b/M_N$	$M_p/M_N$	$M_N$	$R_M$	$U_{SH}$ delta	$U_{SH\ star}$	$C_r$
kW		min <sup>-1</sup>	Hz	W	A			kgcm <sup>2</sup>					Nm	$\Omega$	V DC	V DC	$\mu F$
0.18	8	684	50	230	1.21	0.64	0.58	9.3	2.6	1.1	1.55	1.1	2.51	64	25	-	17
0.18	8	820	60	230	1.2	0.64	0.59	9	2.6	1.6	1.7	1.4	2.1	65	37	-	10
0.18	8	684	50	400	0.7	0.64	0.58	9.3	2.6	1.1	1.55	1.1	2.51	64	-	43	17
0.18	8	820	60	460	0.6	0.64	0.59	9	2.6	1.6	1.7	1.4	2.1	65	-	75	10
0.207	6	920	50	230	1.1	0.68	0.69	9.3	2.7	1.4	1.4	1.24	2.149	47.8	18	-	-
0.207	6	920	50	400	0.64	0.68	0.69	9.3	2.7	1.4	1.4	1.24	2.149	47.8	-	31	-
0.25	6	910	50	230	1.3	0.72	0.67	9.3	3	1.35	1.75	1.35	2.62	44	21	-	18
0.25	6	1103	60	230	1.3	0.72	0.67	9	3	1.66	1.82	1.5	2.16	19.5	14	-	11
0.25	6	910	50	400	0.75	0.72	0.67	9.3	3	1.35	1.75	1.35	2.62	44	-	36	18
0.25	6	1103	60	460	0.65	0.72	0.67	9	3	1.66	1.82	1.5	2.16	19.5	-	27	11
0.25	6	1102	60	575	0.52	0.72	0.67	9	3	1.66	1.82	1.5	2.17	55	-	31	7
0.306	4	1350	50	230	1.26	0.79	0.77	5.6	3	1.34	1.49	1.16	2.165	33.1	16	-	-
0.306	4	1350	50	400	0.73	0.79	0.77	5.6	3	1.34	1.49	1.16	2.165	33.1	-	29	-
0.37	4	1340	50	230	1.68	0.79	0.7	5.6	3.3	1.55	1.95	1.55	2.64	26.5	18	-	23
0.37	4	1608	60	230	1.7	0.78	0.7	5.6	3.3	1.62	1.8	1.4	2.2	26.5	26	-	15
0.37	4	1340	50	400	0.97	0.79	0.7	5.6	3.3	1.55	1.95	1.55	2.64	26.5	-	30	23
0.37	4	1608	60	460	0.85	0.78	0.7	5.6	3.3	1.62	1.8	1.4	2.2	26.5	-	53	15
0.37	4	1655	60	575	0.65	0.78	0.74	5.6	3.7	1.62	1.8	1.5	2.14	41.5	-	32	9
0.455	2	2826	50	230	2.12	0.72	0.74	3.5	5	2.38	2.56	1.98	1.538	14.1	11	-	-
0.455	2	2826	50	400	1.23	0.72	0.74	3.5	5	2.38	2.56	1.98	1.538	14.1	-	19	-
0.55	2	2826	50	230	2.25	0.8	0.76	3.5	5.5	3.2	3.65	3.2	1.86	11.4	10	-	-
0.55	2	3321	60	230	2.2	0.81	0.77	3.5	5.5	2.88	3.1	2.4	1.58	95.8	128	-	-
0.55	2	2826	50	400	1.3	0.8	0.76	3.5	5.5	3.2	3.65	3.2	1.86	11.4	-	18	-
0.55	2	3321	60	460	1.1	0.81	0.77	3.5	5.5	2.88	3.1	2.4	1.58	95.8	-	256	-
0.55	2	3321	60	575	0.9	0.81	0.76	3.5	6.7	2.88	3.1	2.7	1.58	46	-	50	-
0.62	4	1395	50	230	2.66	0.79	0.73	9.9	3.1	1.07	1.24	1.4	4.244	11.8	12	-	-
0.62	4	1395	50	400	1.55	0.79	0.73	9.9	3.1	1.07	1.24	1.4	4.244	11.8	-	22	-
0.75	4	1381	50	230	3.29	0.8	0.71	9.9	3.4	2.1	2.45	2.1	5.19	9.7	13	-	45
0.75	4	1660	60	230	3.3	0.82	0.7	9.9	3.4	1.8	2.1	1.7	4.31	9.45	19	-	29
0.75	4	1381	50	400	1.9	0.8	0.71	9.9	3.4	2.1	2.45	2.1	5.19	9.7	-	22	45
0.75	4	1660	60	460	1.65	0.82	0.7	9.9	3.4	1.8	2.1	1.7	4.31	9.45	-	38	29
0.75	4	1674	60	575	1.3	0.79	0.73	10	3.4	1.3	1.5	1.7	4.28	18.9	-	29	18
0.826	2	2762	50	230	3.13	0.81	0.81	6.2	4.9	1.9	2.07	1.74	2.856	6.8	9	-	-



## Interroll Drum motor series i, S, S/A, D

### i-series product information

$P_N$	$n_p$	$n_N$	$f_N$	$U_N$	$I_N$	$\cos\varphi$	$\eta$	$J_R$	$I_s/I_N$	$M_s/M_N$	$M_B/M_N$	$M_p/M_N$	$M_N$	$R_M$	$U_{SH}$ delta	$U_{SH star}$	$C_r$
kW		min <sup>-1</sup>	Hz	W	A			kgcm <sup>2</sup>					Nm	Ω	V DC	V DC	μF
0.826	2	2762	50	400	1.82	0.81	0.81	6.2	4.9	1.9	2.07	1.74	2.856	6.8	-	15	-
1	2	2775	50	230	4.16	0.8	0.75	6.2	5.4	3.4	3.95	3.4	3.44	5.4	9	-	-
1	2	3330	60	230	4.2	0.8	0.75	6.2	5.4	2.8	3.1	2.5	2.87	5.4	14	-	-
1	2	2775	50	400	2.4	0.8	0.75	6.2	5.4	3.4	3.95	3.4	3.44	5.4	-	16	-
1	2	3330	60	460	2.1	0.8	0.75	6.2	5.4	2.8	3.1	2.5	2.87	5.4	-	27	-
1	2	3330	60	575	1.68	0.81	0.74	6.2	5.4	2.8	3.1	2.5	2.87	12.6	-	26	-

### 165i and 217i\* 3-phase

$P_N$	$n_p$	$n_N$	$f_N$	$U_N$	$I_N$	$\cos\varphi$	$\eta$	$J_R$	$I_s/I_N$	$M_s/M_N$	$M_B/M_N$	$M_p/M_N$	$M_N$	$R_M$	$U_{SH}$ delta	$U_{SH star}$	$C_r$
kW		min <sup>-1</sup>	Hz	W	A			kgcm <sup>2</sup>					Nm	Ω	V DC	V DC	μF
0.37	12	547	60	230	2.8	0.63	0.53	35.1	2	2.1	2.4	1.9	6.46	25	33	-	24
0.37	12	547	60	460	1.4	0.63	0.53	35.1	2	2.1	2.4	1.9	6.46	25	-	66	24
0.62	6	865	50	230	3.3	0.78	0.6	22.6	3.2	1.17	1.2	1.16	6.845	6.2	8	-	-
0.62	6	865	50	400	1.91	0.78	0.6	22.6	3.2	1.17	1.2	1.16	6.845	6.2	-	14	-
0.75	8	691	50	230	3.55	0.74	0.71	35.1	7.6	1.3	1.6	1.3	10.37	15.7	21	-	49
0.75	8	691	50	400	2.05	0.74	0.71	35.1	7.6	1.3	1.6	1.3	10.37	15.7	-	36	49
0.75	6	845	50	230	3.64	0.81	0.64	22.6	3.5	1.75	2	1.75	8.48	6.2	9	-	50
0.75	6	1014	60	230	3.7	0.81	0.63	35.1	3.5	1.4	1.45	1.2	7.06	5.5	12	-	32
0.75	6	845	50	400	2.1	0.81	0.64	22.6	3.5	1.75	2	1.75	8.48	6.2	-	16	50
0.75	6	1014	60	460	1.85	0.81	0.63	35.1	3.5	1.4	1.45	1.2	7.06	5.5	-	25	32
0.75	6	1014	60	575	1.35	0.81	0.69	35.1	3.5	1.41	1.45	1.4	7.06	18.1	-	30	19
1.24	4	1393	50	230	4.94	0.8	0.78	19.8	3.5	1.18	1.21	1.07	8.501	6.2	12	-	-
1.24	4	1393	50	400	2.86	0.8	0.78	19.8	3.5	1.18	1.21	1.07	8.501	6.2	-	21	-
1.5	4	1393	50	230	6.06	0.87	0.71	19.8	3.8	1.55	2.1	1.55	10.28	5.2	14	-	84
1.5	4	1672	60	230	6.2	0.85	0.72	11.3	4.8	1.43	1.46	1.3	8.57	5.155	20	-	54
1.5	4	1393	50	400	3.5	0.87	0.71	19.8	3.8	1.55	2.1	1.55	10.28	5.2	-	24	84
1.5	4	1672	60	460	3.1	0.85	0.72	11.3	4.8	1.43	1.46	1.3	8.57	5.155	-	41	54
1.5	4	1672	60	575	2.5	0.85	0.68	19.8	4.8	1.43	1.46	1.3	8.2	8	-	26	35
1.818	2	2850	50	230	6.43	0.85	0.83	7.6	4.8	2.07	2.31	1.65	6.092	6.2	17	-	-
1.818	2	2850	50	400	3.73	0.85	0.83	7.6	4.8	2.07	2.31	1.65	6.092	6.2	-	29	-
2.2	2	2840	50	230	7.88	0.86	0.81	7.6	5.3	2.6	3.2	2.6	7.4	6.2	21	-	-



## Interroll Drum motor series i, S, S/A, D

### i-series product information

$P_N$	$n_p$	$n_N$	$f_N$	$U_N$	$I_N$	$\cos\varphi$	$\eta$	$J_R$	$I_s/I_N$	$M_s/M_N$	$M_b/M_N$	$M_p/M_N$	$M_N$	$R_M$	$U_{SH}$ delta	$U_{SH\ star}$	$C_r$
kW		min <sup>-1</sup>	Hz	W	A			kgcm <sup>2</sup>					Nm	$\Omega$	V DC	V DC	$\mu F$
2.2	2	3408	60	230	8	0.86	0.8	7.6	3.4	3.2	2	3.2	6.16	2.35	12	-	-
2.2	2	2840	50	400	4.55	0.86	0.81	7.6	5.3	2.6	3.2	2.6	7.4	6.2	-	36	-
2.2	2	3408	60	460	4	0.86	0.8	7.6	3.4	3.2	2	3.2	6.16	2.35	-	24	-
2.2	2	3408	60	575	3.2	0.86	0.8	7.6	5.3	3.2	3.4	3.2	6.16	7.8	-	32	-
0.15	12	456	50	230	1.13	0.6	0.56	22.6	5.37	1	1.3	1	3.14	75.5	26	-	16
0.15	12	456	50	400	0.65	0.6	0.56	22.6	5.37	1	1.3	1	3.14	75.5	-	44	16
0.306	12	456	50	230	2.51	0.62	0.49	35.1	1.8	1.74	1.98	1.57	6.409	22.4	17	-	-
0.306	12	456	50	400	1.45	0.62	0.49	35.1	1.8	1.74	1.98	1.57	6.409	22.4	-	30	-
0.306	8	840	50	230	1.97	0.62	0.62	22.6	2.9	1.24	1.4	1.16	3.479	28	17	-	-
0.306	8	840	50	400	1.15	0.62	0.62	22.6	2.9	1.24	1.4	1.16	3.479	28	-	30	-
0.37	12	456	50	230	2.77	0.63	0.53	35.1	2	1.2	1.5	1.2	7.75	19.39	17	-	38
0.37	12	456	50	400	1.6	0.63	0.53	35.1	2	1.2	1.5	1.2	7.75	19.39	-	29	38
0.37	8	690	50	230	2.42	0.62	0.57	22.6	2.87	1.9	2.35	1.9	5.12	22	17	-	36
0.37	8	828	60	230	2.8	0.62	0.54	22.6	2.8	1.7	1.9	1.6	4.27	18.5	24	-	24
0.37	8	690	50	400	1.5	0.62	0.57	22.6	2.87	1.9	2.35	1.9	5.12	22	-	31	36
0.37	8	828	60	460	1.4	0.62	0.54	22.6	2.8	1.7	1.9	1.6	4.27	18.5	-	48	24
0.37	4	1375	50	230	1.9	0.77	0.66	11.3	3.2	1.6	1.8	1.6	2.7	29.2	21	-	-
0.37	4	1375	50	400	1.1	0.77	0.66	11.3	3.2	1.6	1.8	1.6	2.7	29.2	-	37	-
0.455	6	845	50	230	2.04	0.75	0.74	22.6	3.1	1.07	1.07	1.07	5.142	25	19	-	-
0.455	6	845	50	400	1.18	0.75	0.74	22.6	3.1	1.07	1.07	1.07	5.142	25	-	33	-
0.55	6	845	50	230	2.77	0.69	0.72	22.6	3.4	1.4	1.65	1.4	6.22	19.5	19	-	38
0.55	6	1060	60	230	2.6	0.8	0.67	22.6	3.4	2.2	2.3	2.1	4.96	19.35	30	-	22
0.55	6	845	50	400	1.6	0.69	0.72	22.6	3.4	1.4	1.65	1.4	6.22	19.5	-	32	38
0.55	6	1060	60	460	1.3	0.8	0.67	22.6	3.4	2.2	2.3	2.1	4.96	19.35	-	60	22
0.62	4	1378	50	230	2.55	0.8	0.76	11.3	3.6	1.26	1.49	1.07	4.297	14.4	15	-	-
0.62	4	1378	50	400	1.48	0.8	0.76	11.3	3.6	1.26	1.49	1.07	4.297	14.4	-	26	-
0.75	4	1355	50	230	3.12	0.8	0.75	11.3	3.5	1.53	1.8	1.3	5.29	23.9	30	-	43
0.75	4	1584	60	230	3.1	0.76	0.8	11.3	1.8	1.53	1.4	1.53	4.52	11.95	21	-	27
0.75	4	1355	50	400	1.8	0.8	0.75	11.3	3.5	1.53	1.8	1.3	5.29	23.9	-	52	43
0.75	4	1584	60	460	1.55	0.76	0.8	11.3	1.8	1.53	1.4	1.53	4.52	11.95	-	42	27
0.909	4	1320	50	230	3.92	0.84	0.69	11.3	3.7	1.16	1.24	1.07	6.576	8.3	14	-	-
0.909	4	1320	50	400	2.27	0.84	0.69	11.3	3.7	1.16	1.24	1.07	6.576	8.3	-	24	-
0.909	2	2860	50	230	3.3	0.86	0.8	7.3	4.6	2.48	2.64	1.74	3.035	6.2	9	-	-

## Interroll Drum motor series i, S, S/A, D

### i-series product information

$P_N$	$n_p$	$n_N$	$f_N$	$U_N$	$I_N$	$\cos\varphi$	$\eta$	$J_R$	$I_s/I_N$	$M_s/M_N$	$M_B/M_N$	$M_p/M_N$	$M_N$	$R_M$	$U_{SH}$ delta	$U_{SH star}$	$C_r$
kW		min <sup>-1</sup>	Hz	W	A			kgcm <sup>2</sup>					Nm	Ω	V DC	V DC	μF
0.909	2	2860	50	400	1.91	0.86	0.8	7.3	4.6	2.48	2.64	1.74	3.035	6.2	-	15	-
1.1	4	1320	50	230	4.85	0.82	0.69	11.3	3.5	1.5	1.7	1.3	7.96	7.2	14	-	67
1.1	4	1320	50	400	2.8	0.82	0.69	11.3	3.5	1.5	1.7	1.3	7.96	7.2	-	25	67
1.1	2	3414	60	230	4.2	0.86	0.77	6.8	3.42	3.15	2.1	3.15	3.08	2.9	8	-	-
1.1	2	2845	50	230	4.16	0.86	0.77	7.6	5.2	3.15	3.42	2.1	3.69	2.9	5	-	-
1.1	2	3414	60	460	2.1	0.86	0.77	6.8	3.42	3.15	2.1	3.15	3.08	2.9	-	16	-
1.1	2	2845	50	400	2.4	0.86	0.77	7.6	5.2	3.15	3.42	2.1	3.69	2.9	-	9	-

### 217i 3-phase

$P_N$	$n_p$	$n_N$	$f_N$	$U_N$	$I_N$	$\cos\varphi$	$\eta$	$J_R$	$I_s/I_N$	$M_s/M_N$	$M_B/M_N$	$M_p/M_N$	$M_N$	$R_M$	$U_{SH}$ delta	$U_{SH star}$	$C_r$
kW		min <sup>-1</sup>	Hz	W	A			kgcm <sup>2</sup>					Nm	Ω	V DC	V DC	μF
0.306	8	840	50	230	1.97	0.62	0.62	22.6	2.9	1.24	1.4	1.16	3.479	28	17	-	-
0.306	8	840	50	400	1.15	0.62	0.62	22.6	2.9	1.24	1.4	1.16	3.479	28	-	30	-
0.37	8	690	50	230	2.42	0.62	0.57	22.6	2.87	1.9	2.35	1.9	5.12	22	17	-	36
0.37	8	690	50	400	1.5	0.62	0.57	22.6	2.87	1.9	2.35	1.9	5.12	22	-	31	36
0.455	6	845	50	230	2.04	0.75	0.74	22.6	3.1	1.07	1.07	1.07	5.142	25	19	-	-
0.455	6	845	50	400	1.18	0.75	0.74	22.6	3.1	1.07	1.07	1.07	5.142	25	-	33	-
0.55	6	845	50	230	2.77	0.69	0.72	22.6	3.4	1.4	1.65	1.4	6.22	19.5	19	-	38
0.55	6	845	50	400	1.6	0.69	0.72	22.6	3.4	1.4	1.65	1.4	6.22	19.5	-	32	38
0.62	4	1378	50	230	2.55	0.8	0.76	11.3	3.6	1.26	1.49	1.07	4.297	14.4	15	-	-
0.62	4	1378	50	400	1.48	0.8	0.76	11.3	3.6	1.26	1.49	1.07	4.297	14.4	-	26	-
0.75	4	1355	50	230	3.12	0.8	0.75	11.3	3.5	1.53	1.8	1.3	5.29	23.9	30	-	43
0.75	4	1355	50	400	1.8	0.8	0.75	11.3	3.5	1.53	1.8	1.3	5.29	23.9	-	52	43
0.9	6	925	50	230	3.98	0.81	0.7	86	3.9	1.75	1.95	1.7	9.29	10.8	17	-	55
0.9	6	925	50	400	2.3	0.81	0.7	86	3.9	1.75	1.95	1.7	9.29	10.8	-	30	55
0.909	4	1320	50	230	3.92	0.84	0.69	11.3	3.7	1.16	1.24	1.07	6.576	8.3	14	-	-
0.909	4	1320	50	400	2.27	0.84	0.69	11.3	3.7	1.16	1.24	1.07	6.576	8.3	-	24	-
0.909	2	2860	50	230	3.3	0.86	0.8	7.3	4.6	2.48	2.64	1.74	3.035	6.2	9	-	-
0.909	2	2860	50	400	1.91	0.86	0.8	7.3	4.6	2.48	2.64	1.74	3.035	6.2	-	15	-
1.1	8	695	50	230	5.54	0.81	0.61	86	4.5	1.8	2.2	1.7	15.12	6.3	14	-	76
1.1	8	695	50	400	3.2	0.81	0.61	86	4.5	1.8	2.2	1.7	15.12	6.3	-	24	76



## Interroll Drum motor series i, S, S/A, D

### i-series product information

$P_N$	$n_p$	$n_N$	$f_N$	$U_N$	$I_N$	$\cos\varphi$	$\eta$	$J_R$	$I_s/I_N$	$M_s/M_N$	$M_B/M_N$	$M_p/M_N$	$M_N$	$R_M$	$U_{SH}$ delta	$U_{SH\ star}$	$C_r$
<b>kW</b>		$\text{min}^{-1}$	Hz	W	A			$\text{kgcm}^2$					Nm	$\Omega$	V DC	V DC	$\mu\text{F}$
1.1	4	1320	50	230	4.85	0.82	0.69	11.3	3.5	1.5	1.7	1.3	7.96	7.2	14	-	67
1.1	4	1320	50	400	2.8	0.82	0.69	11.3	3.5	1.5	1.7	1.3	7.96	7.2	-	25	67
1.1	2	2845	50	230	4.16	0.86	0.77	7.6	5.2	3.15	3.42	2.1	3.69	2.9	5	-	-
1.1	2	2845	50	400	2.4	0.86	0.77	7.6	5.2	3.15	3.42	2.1	3.69	2.9	-	9	-
1.5	6	960	50	230	6.93	0.82	0.66	86	4.8	2.1	2.5	1.9	14.92	4.3	12	-	95
1.5	6	960	50	400	4	0.82	0.66	86	4.8	2.1	2.5	1.9	14.92	4.3	-	21	95
1.5	4	1410	50	230	6.41	0.87	0.67	49.6	5.5	2.2	2.5	1.8	10.16	3.6	10	-	88
1.5	4	1410	50	400	3.7	0.87	0.67	49.6	5.5	2.2	2.5	1.8	10.16	3.6	-	17	88
1.5	2	2781	50	230	6.41	0.85	0.69	26	6.4	2.7	3.2	2.4	5.15	4.5	12	-	-
1.5	2	2781	50	400	3.7	0.85	0.69	26	6.4	2.7	3.2	2.4	5.15	4.5	-	21	-
2.2	6	934	50	230	9.87	0.8	0.7	86	5	2.1	2.5	1.9	22.49	3.6	14	-	136
2.2	6	934	50	400	5.7	0.8	0.7	86	5	2.1	2.5	1.9	22.49	3.6	-	25	136
2.2	4	1420	50	230	9.01	0.87	0.7	60	5.9	2.4	2.9	2.3	14.8	3.55	14	-	124
2.2	4	1420	50	400	5.2	0.87	0.7	60	5.9	2.4	2.9	2.3	14.8	3.55	-	24	124
2.2	2	2794	50	230	8.83	0.88	0.71	26	6.4	2.6	3.02	2.3	7.52	2.95	11	-	-
2.2	2	2794	50	400	5.1	0.88	0.71	26	6.4	2.6	3.02	2.3	7.52	2.95	-	20	-
3	4	1420	50	230	12.12	0.82	0.76	46.9	5	2.4	2.9	2.3	20.18	1.85	9	-	167
3	4	1420	50	400	7	0.82	0.76	46.9	5	2.4	2.9	2.3	20.18	1.85	-	16	167
3	2	2812	50	230	11.52	0.82	0.8	38.1	6.5	2.6	3.4	2.4	10.19	1.55	7	-	-
3	2	2812	50	400	6.65	0.82	0.8	38.1	6.5	2.6	3.4	2.4	10.19	1.55	-	13	-

## Interroll Drum motor series i, S, S/A, D

### i-series product information

#### Dimensions of i-series drum motor

Some dimensions are listed as "SL+". SL is the abbreviation for "shell length" (tube length). This information is located on the type plate of the drum motor (see "Type plate of i-series drum motor", page 18).

All the length-dependent dimensions in the catalog and in this manual comply with the requirements of DIN/ISO 2768 (medium quality).



The recommended distance between the mounting brackets (EL) under consideration of the maximum thermal expansion and internal tolerances is  $EL + 2$  mm.

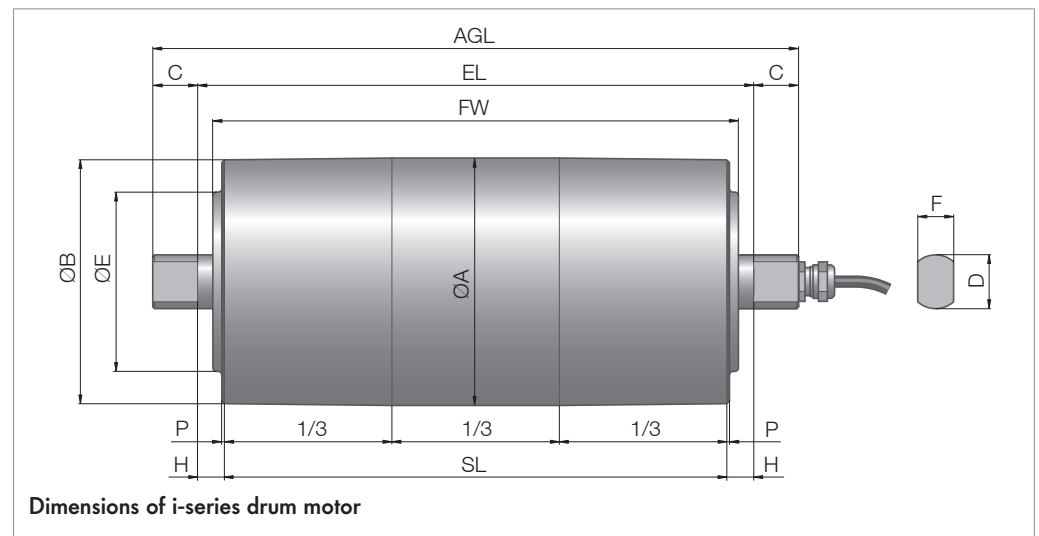

Dimensions of i-series drum motor

Type	A mm	B mm	C mm	D mm	E mm	F mm	H mm	P mm	FW mm	EL mm	AGL mm
80i cambered	81.5	80.5	12.5	17	43	13.5	6	2	SL+7	SL+12	SL+37
80i cylindrical	81	81	12.5	17	43	13.5	6	2	SL+7	SL+12	SL+37
80i cylindrical + key	81.7	81.7	12.5	17	43	13.5	6	2	SL+7	SL+12	SL+37
113i cambered	113.5	112	25	25	83	20	10	1.5	SL+10.6	SL+20	SL+70
113i cylindrical	112	112	25	25	83	20	10	1.5	SL+10.6	SL+20	SL+70
113i cylindrical + key	113	113	25	25	83	20	10	1.5	SL+10.6	SL+20	SL+70
138i cambered	138	136	25	30	100	20	15	1.5	SL+13	SL+30	SL+80
138i cylindrical	136	136	25	30	100	20	15	1.5	SL+13	SL+30	SL+80
138i cylindrical + key	137	137	25	30	100	20	15	1.5	SL+13	SL+30	SL+80
165i cambered	164	162	45	40	130	30	20	1.5	SL+17	SL+40	SL+130
165i cylindrical	162	162	45	40	130	30	20	1.5	SL+17	SL+40	SL+130
165i cylindrical + key	162	162	45	40	130	30	20	1.5	SL+17	SL+40	SL+130
217i cambered	217.5	215.5	45	40	130	30	20	1.5	SL+17	SL+40	SL+130
217i cylindrical	215.5	215.5	45	40	130	30	20	1.5	SL+17	SL+40	SL+130

## Interroll Drum motor series i, S, S/A, D

### i-series product information

#### Connection diagrams for the i-series

This instruction manual lists only standard connection diagrams. For other connection types, the connection diagram is supplied separately with the drum motor.

Abbreviations see "List of abbreviations", page 108

#### Cable connections

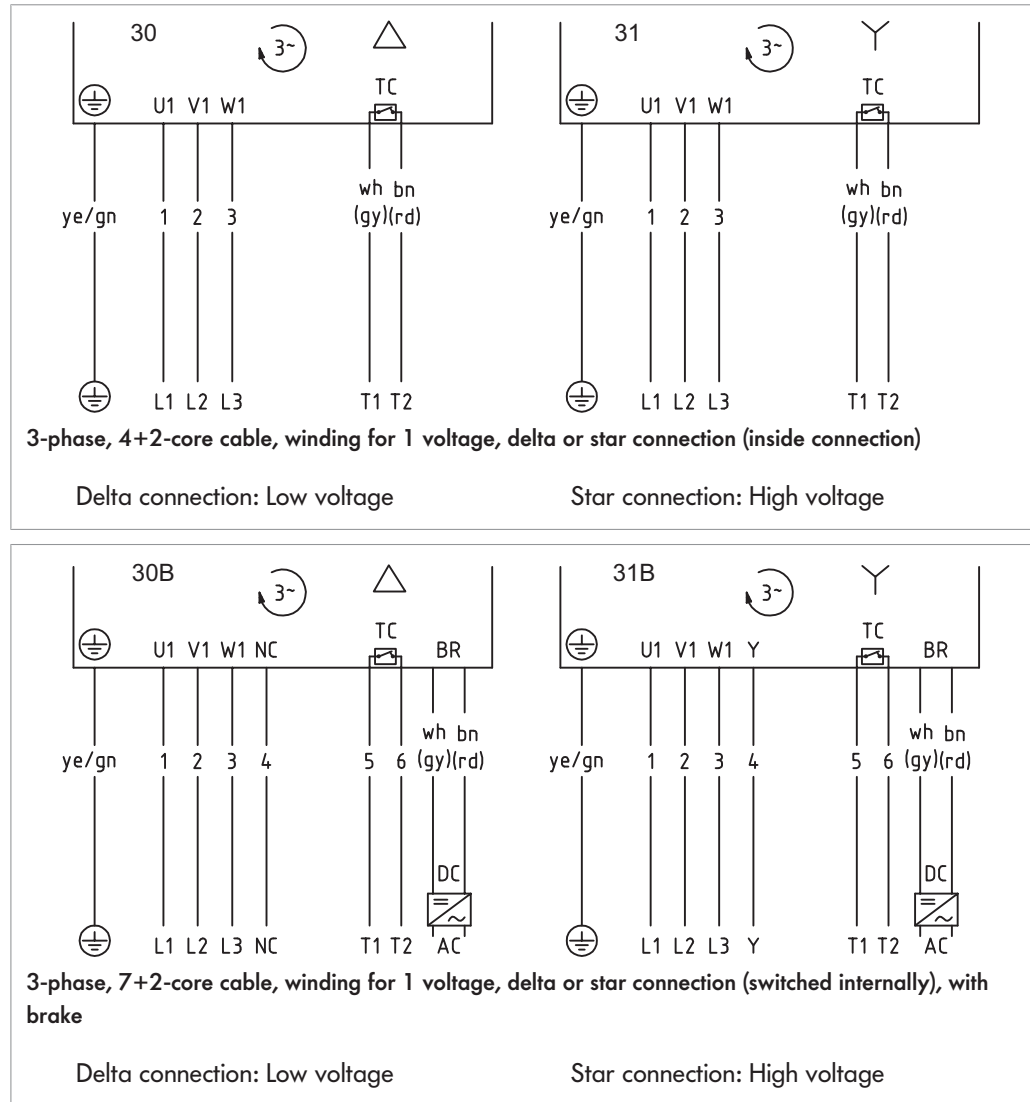

## Interroll Drum motor series i, S, S/A, D

### i-series product information

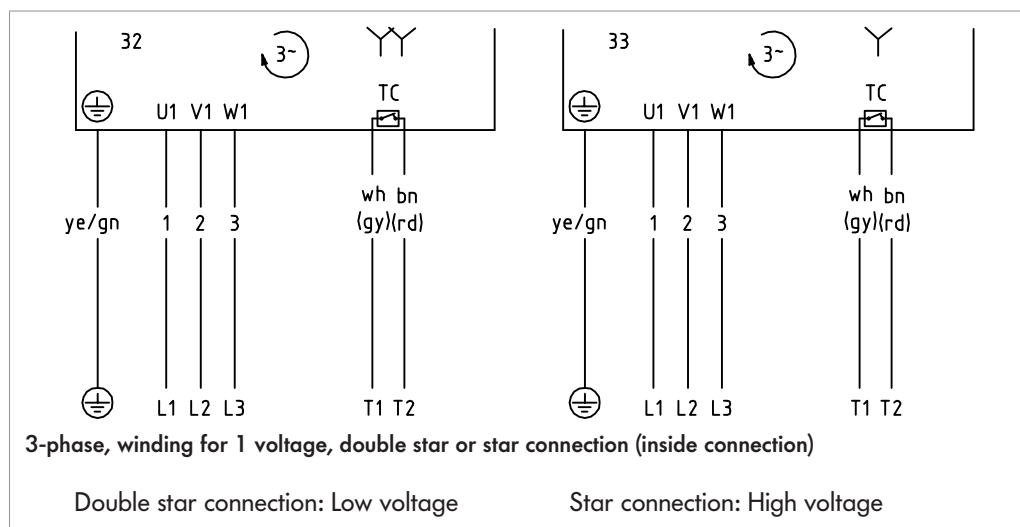
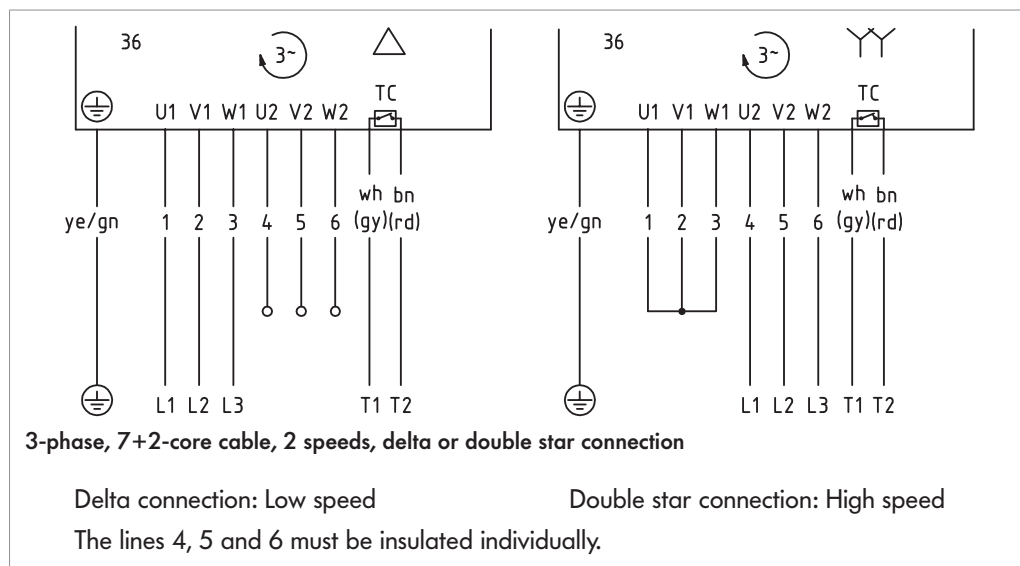
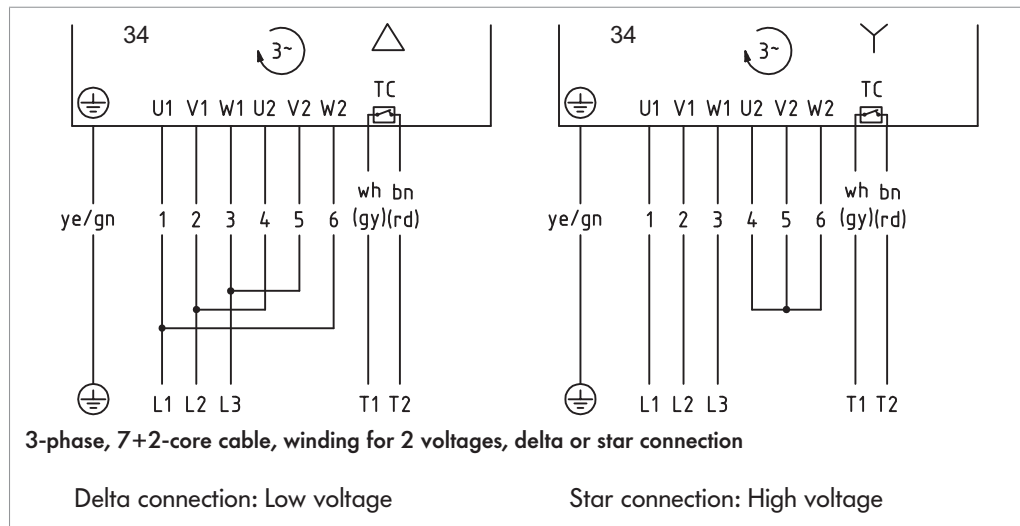

## Interroll Drum motor series i, S, S/A, D

### i-series product information

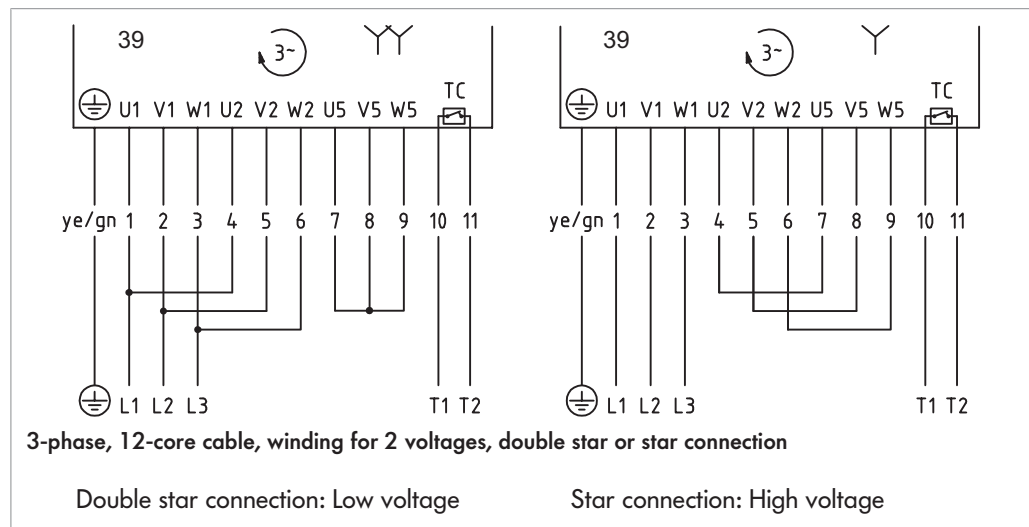
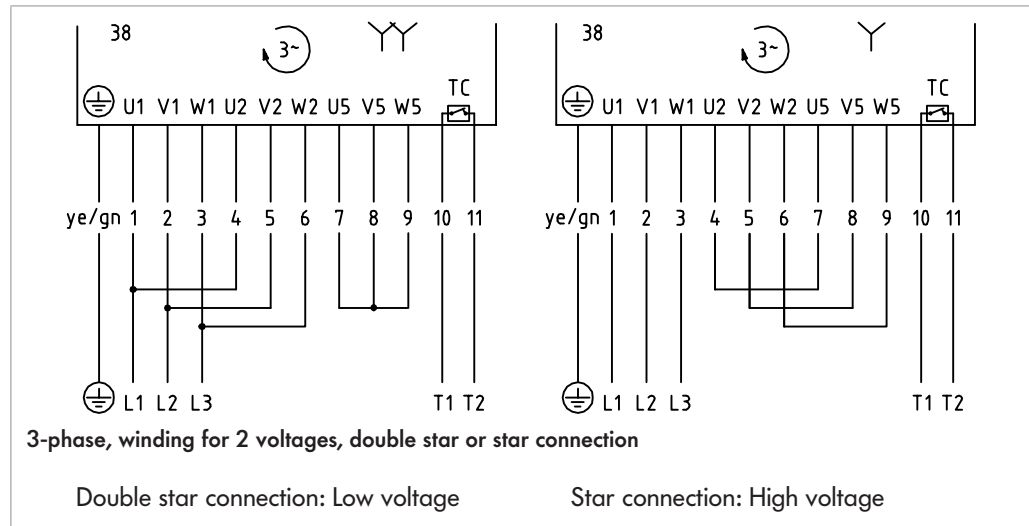
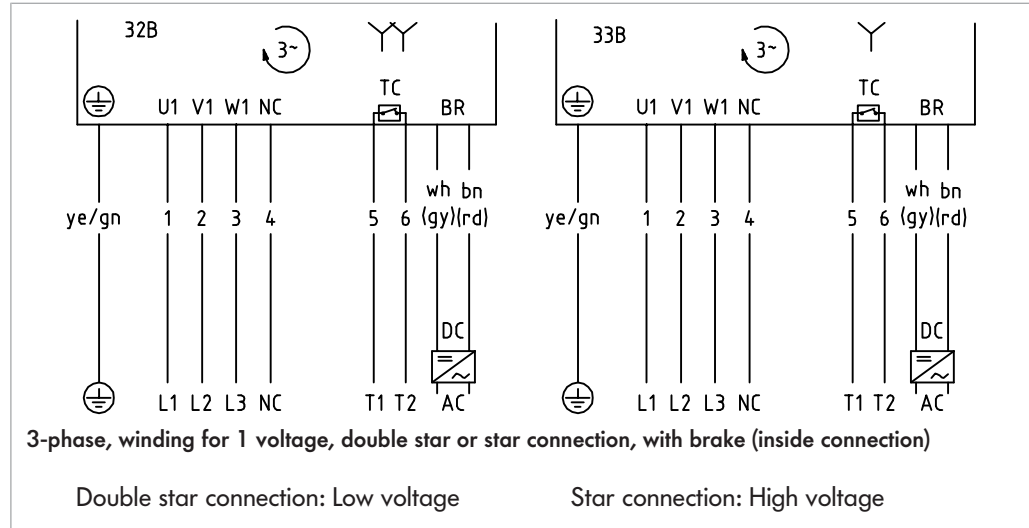



# Interroll Drum motor series i, S, S/A, D

## i-series product information

### Connections in the terminal box

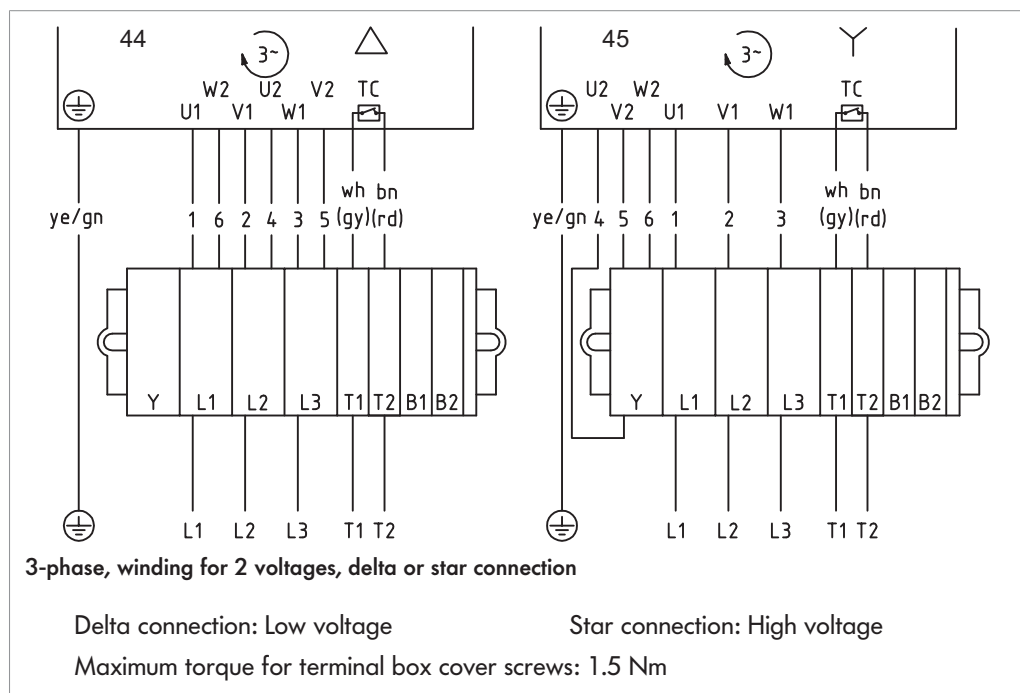
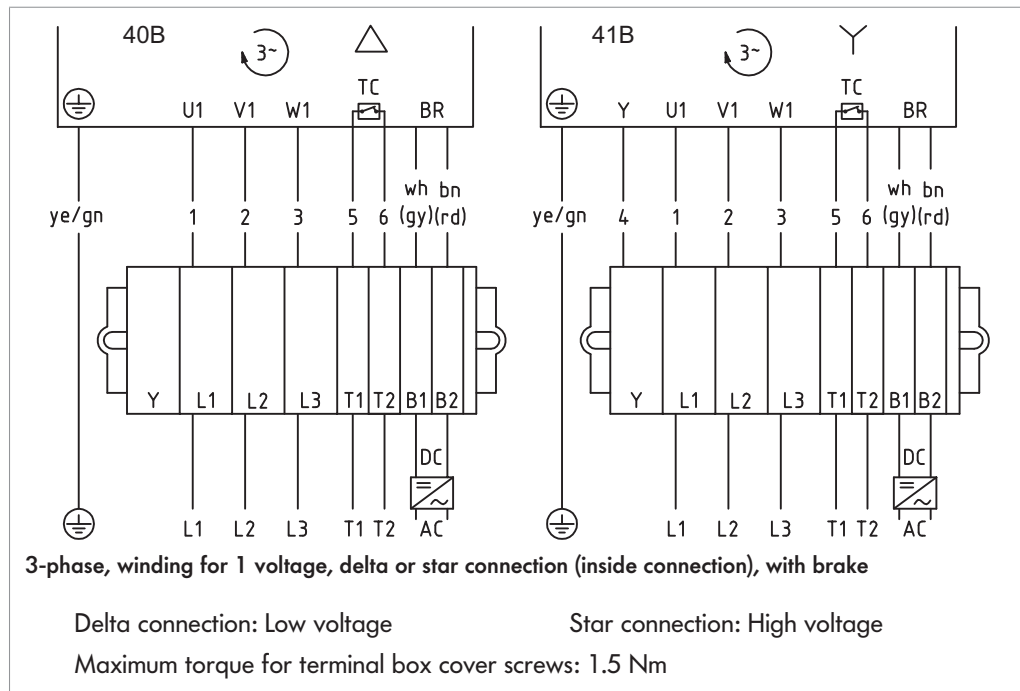

## Interroll Drum motor series i, S, S/A, D

### i-series product information

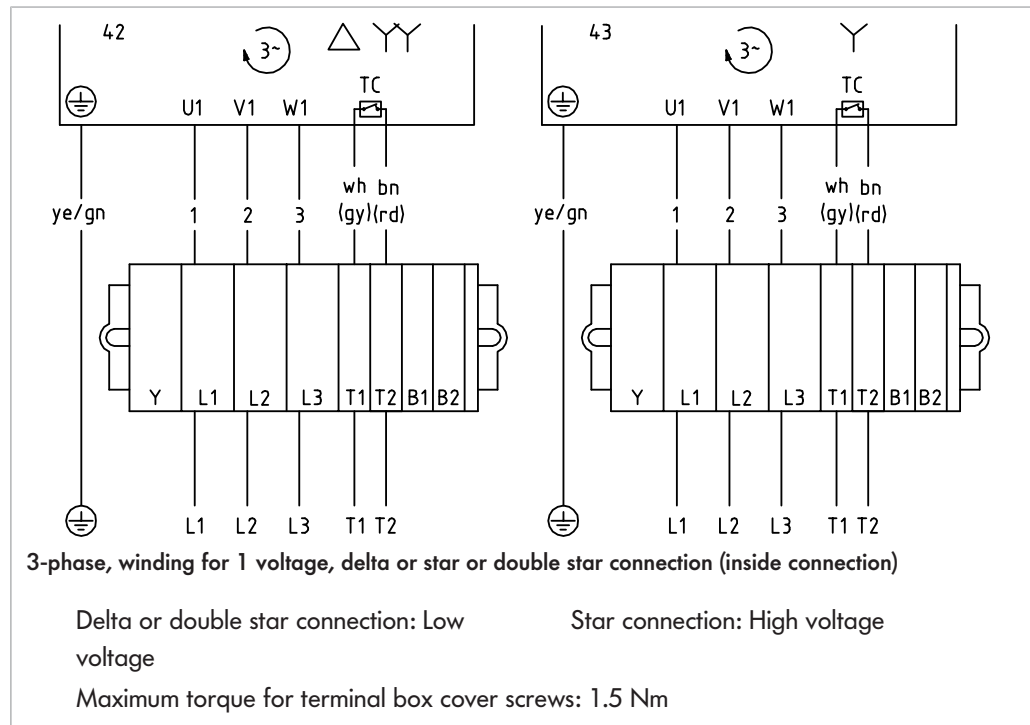
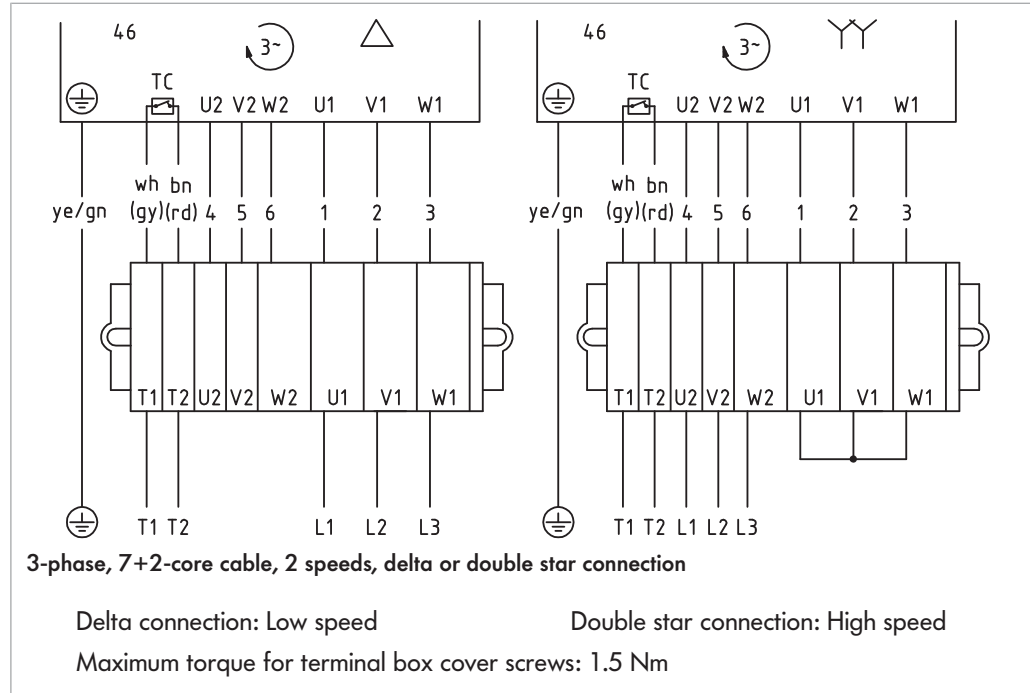

## Interroll Drum motor series i, S, S/A, D

### i-series product information

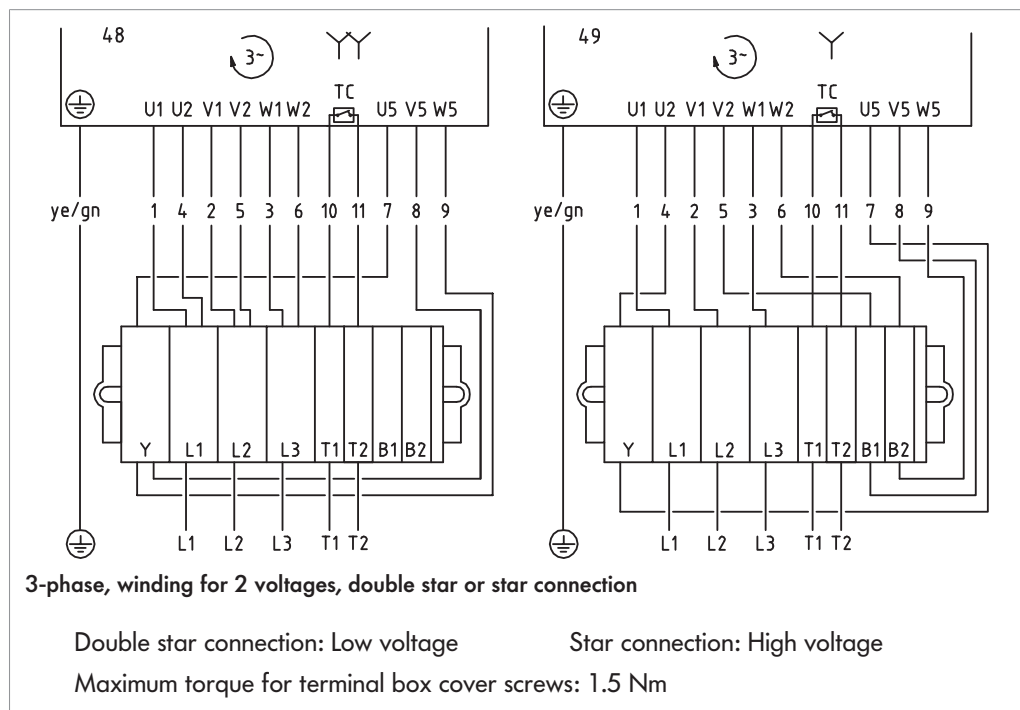
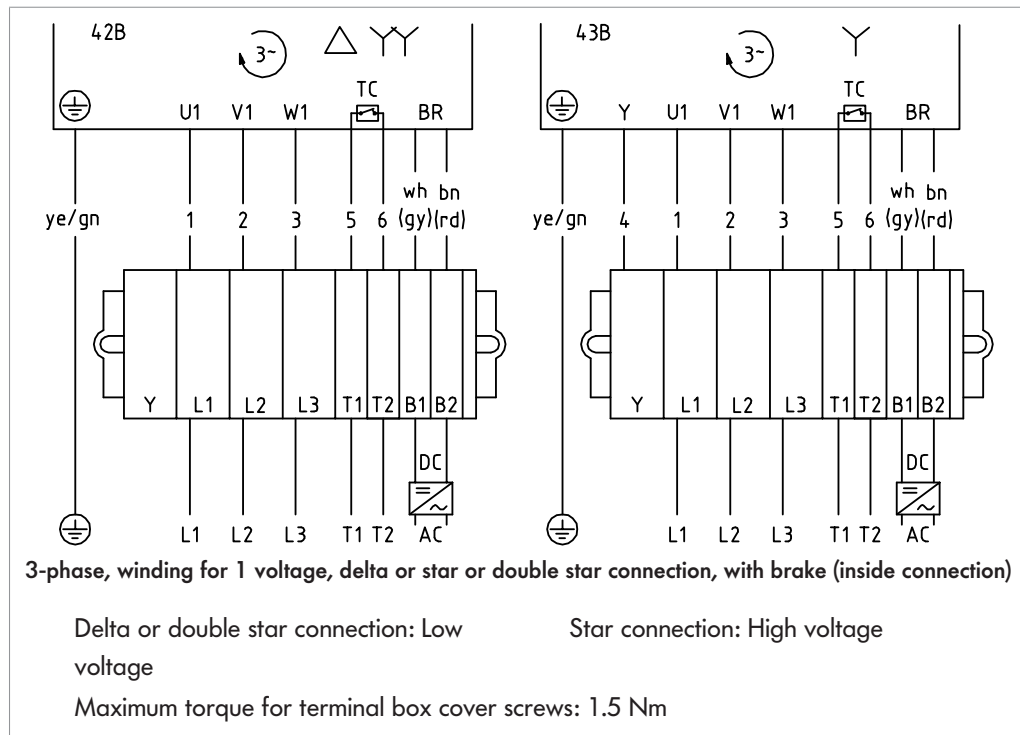

## Interroll Drum motor series i, S, S/A, D

### i-series product information

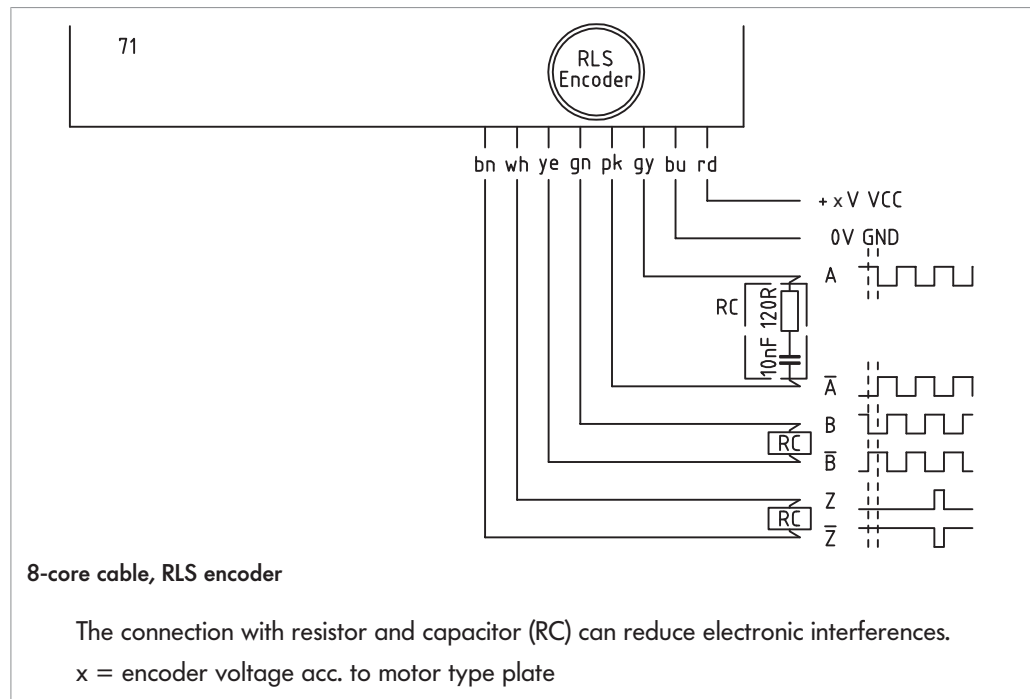
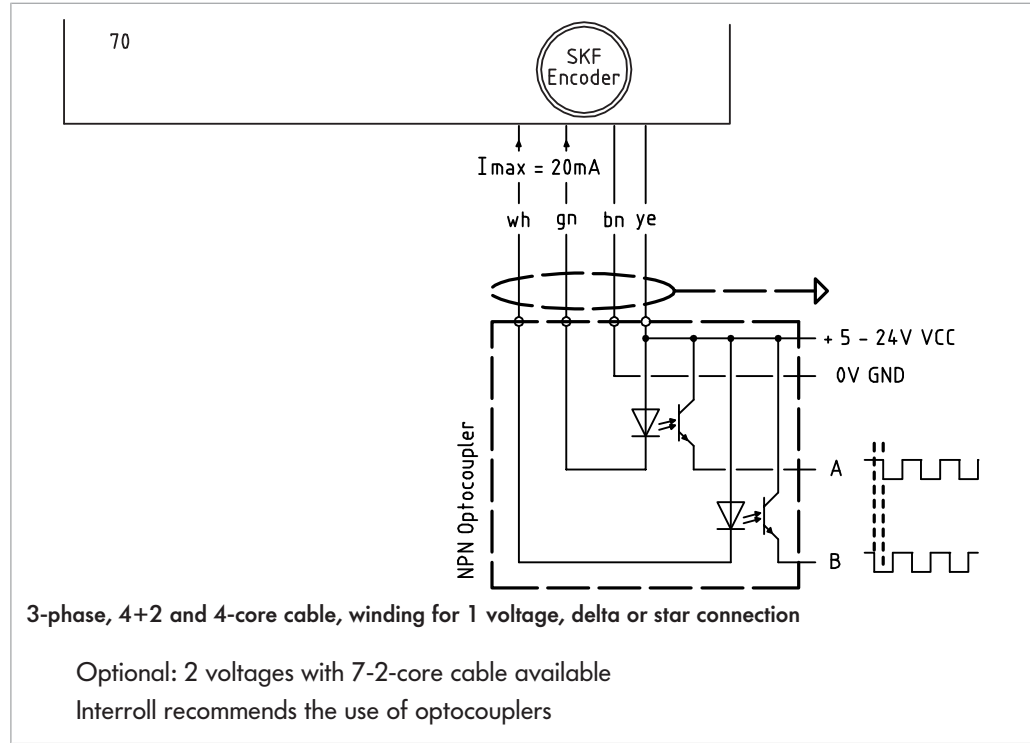

## Interroll Drum motor series i, S, S/A, D

### i-series product information

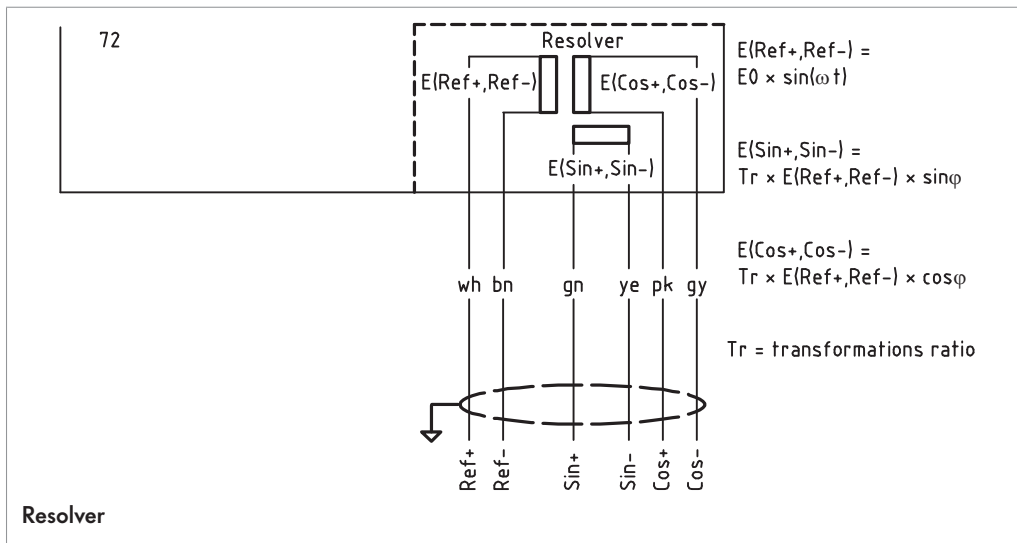

## S-series product information

### Type plate of S-series drum motor

The information on the type plate of the drum motor is intended for its identification. This is the only way for the drum motor to be used properly.

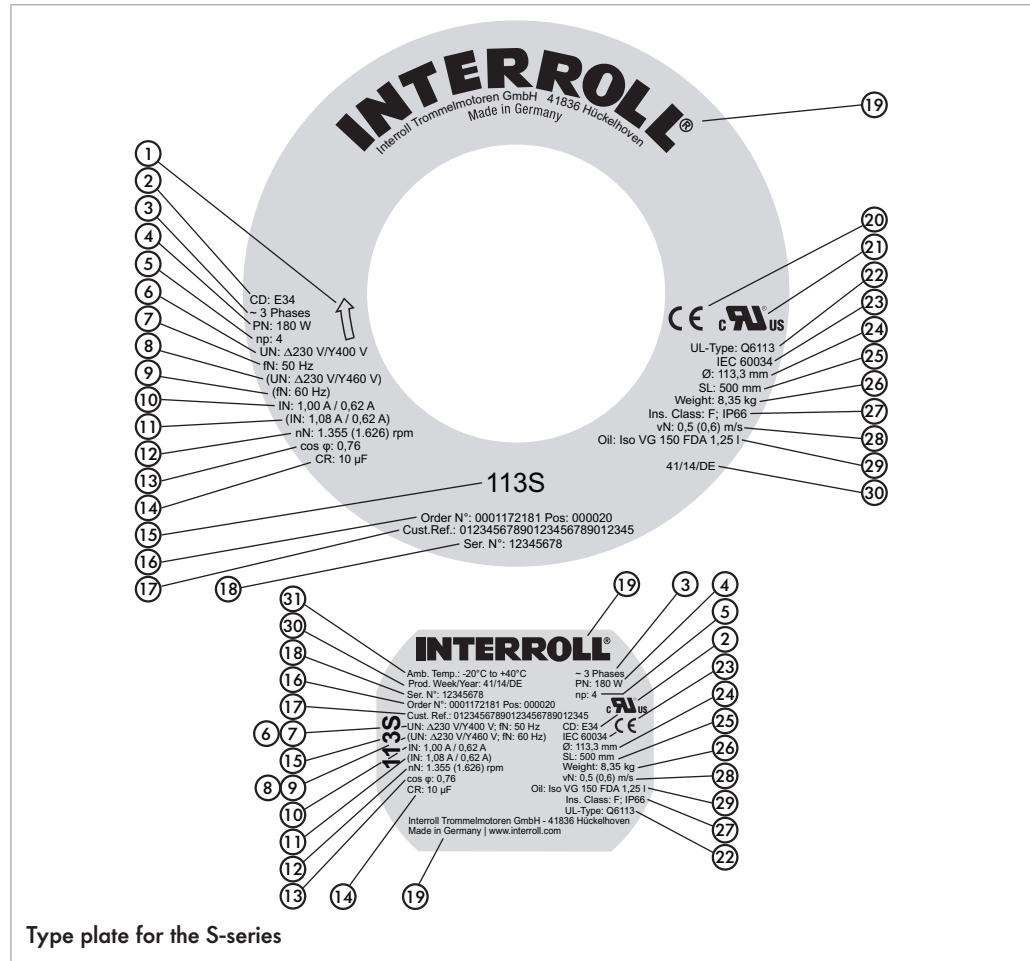

Type plate for the S-series

- |   |                                 |    |                                       |
|---|---------------------------------|----|---------------------------------------|
| 1 | Direction of travel             | 17 | Customer part number                  |
| 2 | Connection diagram number       | 18 | Serial number                         |
| 3 | Number of phases                | 19 | Manufacturer / manufacturing location |
| 4 | Rated power                     | 20 | CE mark                               |
| 5 | Number of poles                 | 21 | UL mark                               |
| 6 | Rated voltage                   | 22 | Type of UL standard                   |
| 7 | Rated frequency                 | 23 | Standard for drum motors              |
| 8 | (rated voltage) <sup>1)</sup>   | 24 | Max. diameter of tube                 |
| 9 | (rated frequency) <sup>1)</sup> | 25 | Roller or tube length                 |

## Interroll Drum motor series i, S, S/A, D

---

### S-series product information

10	Rated current	26	Weight
11	(rated current) <sup>1)</sup>	27	Insulation class and IP rating
12	Rated speed of rotor <sup>1)</sup>	28	Circumferential speed of tube
13	Power factor	29	Oil type
14	Run capacitor	30	Date of manufacture (week/year/country)
15	Type	31	Permissible ambient temperature
16	Part number		

<sup>1)</sup> The value depends on the voltage used. All values in parentheses refer to the rated voltage in parentheses.

## Interroll Drum motor series i, S, S/A, D

### S-series product information

#### Electrical data of S-series

Abbreviations see "List of abbreviations", page 108

#### 80S 1-phase

$P_N$	$n_p$	$n_N$	$f_N$	$U_N$	$I_N$	$\cos\varphi$	$\eta$	$J_R$	$I_s/I_N$	$M_s/M_N$	$M_B/M_N$	$M_p/M_N$	$M_N$	$R_M$	$U_{SH\sim}$	$C_r$
kW		min <sup>-1</sup>	Hz	W	A			kgcm <sup>2</sup>					Nm	$\Omega$	V DC	$\mu F$
0.025	4	1320	50	230	0.39	1	0.28	1.3	2.19	1.11	1.37	1.11	0.18	150	44	3
0.05	2	2750	50	230	0.54	1	0.4	0.9	3.08	0.94	1.71	0.94	0.17	82	33	3
0.075	2	2750	50	230	0.68	1	0.48	1	3.19	0.74	1.37	0.74	0.26	66	34	4
0.075	2	3300	60	230	0.68	1	0.49	1.3	4.89	1	1.83	1	0.22	38	19	6
0.085	2	2750	50	230	0.73	0.98	0.53	1.3	5.24	0.93	1.6	0.93	0.3	52	28	6
0.085	2	2750	50	230	0.73	0.98	0.53	1.3	5.24	0.93	1.6	0.93	0.3	52	28	6
0.085	2	3300	60	230	0.72	1	0.52	1.3	4.89	1	1.83	1	0.25	38	20	6
0.11	2	2750	50	230	0.94	1	0.51	1.3	1.97	0.73	1.15	0.73	0.38	51	36	8

#### 80S 3-phase

$P_N$	$n_p$	$n_N$	$f_N$	$U_N$	$I_N$	$\cos\varphi$	$\eta$	$J_R$	$I_s/I_N$	$M_s/M_N$	$M_B/M_N$	$M_p/M_N$	$M_N$	$R_M$	$U_{SH}$ delta	$U_{SH\ star}$	$C_r$
kW		min <sup>-1</sup>	Hz	W	A			kgcm <sup>2</sup>					Nm	$\Omega$	V DC	V DC	$\mu F$
0.04	4	1320	50	230	0.71	0.65	0.21	1	1.77	1.6	1.6	1.6	0.29	156.5	36	-	10
0.04	4	1320	50	400	0.43	0.65	0.21	1	1.77	1.6	1.6	1.6	0.29	156.5	-	66	10
0.05	2	2750	50	230	0.46	0.57	0.47	1	4.58	3.82	3.82	3.82	0.17	111.3	-	-	-
0.05	2	3300	60	230	0.45	0.64	0.42	1	5.67	3.29	3.29	3.29	0.14	111.3	-	-	-
0.05	2	2750	50	400	0.22	0.71	0.45	1	4.35	2.35	2.35	2.35	0.17	171	-	40	-
0.06	4	1320	50	230	0.79	0.65	0.29	1	1.77	1.6	1.6	1.6	0.43	156.5	40	-	11
0.06	4	1584	60	230	0.76	0.65	0.15	1	1.72	1.6	1.6	1.6	0.36	156.5	39	-	13
0.06	4	1320	50	400	0.46	0.65	0.29	1	1.77	1.6	1.6	1.6	0.43	156.5	-	70	11
0.06	4	1584	60	460	0.76	0.65	0.15	1	1.72	1.6	1.6	1.6	0.36	156.5	-	116	13
0.075	2	2820	50	230	0.51	0.69	0.53	1	4.58	2.5	2.5	2.5	0.25	111.3	-	-	-
0.075	2	3300	60	230	0.49	0.74	0.53	1	5.67	2.19	2.19	2.19	0.22	111.3	-	-	-
0.075	2	2820	50	400	0.3	0.7	0.51	1	4.46	2.5	2.5	2.5	0.25	113	-	36	-
0.075	2	3300	60	460	0.28	0.7	0.49	1	5.23	2.95	2.95	2.95	0.22	113	-	33	-
0.085	2	2800	50	230	0.53	0.73	0.55	1	4.58	2.24	2.24	2.24	0.29	111.3	-	-	-
0.085	2	3300	60	230	0.5	0.78	0.56	1	5.67	1.92	1.92	1.92	0.25	111.3	-	-	-
0.085	2	2800	50	400	0.32	0.74	0.52	1	4.46	2.24	2.24	2.24	0.29	113	-	40	-



## Interroll Drum motor series i, S, S/A, D

### S-series product information

$P_N$	$n_p$	$n_N$	$f_N$	$U_N$	$I_N$	$\cos\varphi$	$\eta$	$J_R$	$I_s/I_N$	$M_s/M_N$	$M_b/M_N$	$M_p/M_N$	$M_N$	$R_M$	$U_{SH}$ delta	$U_{SH\ star}$	$C_r$
kW		min <sup>-1</sup>	Hz	W	A			kgcm <sup>2</sup>					Nm	Ω	V DC	V DC	μF
0.085	2	3300	60	460	0.29	0.74	0.51	1	5.23	2.71	2.71	2.71	0.25	113	-	36	-

#### 113S 1-phase

$P_N$	$n_p$	$n_N$	$f_N$	$U_N$	$I_N$	$\cos\varphi$	$\eta$	$J_R$	$I_s/I_N$	$M_s/M_N$	$M_b/M_N$	$M_p/M_N$	$M_N$	$R_M$	$U_{SH \sim}$	$C_r$
kW		min <sup>-1</sup>	Hz	W	A			kgcm <sup>2</sup>					Nm	Ω	V DC	μF
0.06	4	1300	50	230	0.75	0.98	0.36	2.3	2.58	1.29	2.6	1.29	0.44	63.5	35	4
0.06	4	1560	60	230	0.86	0.97	0.32	2.3	2.58	1.29	2.6	1.29	0.37	63.5	40	4
0.08	6	890	50	230	1.35	0.99	0.26	4	1.88	0.7	1.65	0.7	0.86	45.9	46	8
0.09	4	1300	50	230	0.99	0.91	0.43	2.3	2.42	1.24	2.42	1.24	0.66	42.5	29	6
0.09	4	1300	50	230	0.99	0.91	0.43	2.3	2.42	1.24	2.42	1.24	0.66	42.5	29	6
0.09	4	1560	60	230	1.1	0.96	0.37	2.3	2.42	1.24	2.42	1.24	0.55	42.5	34	6
0.09	4	1560	60	230	1.1	0.96	0.37	2.3	2.42	1.24	2.42	1.24	0.55	42.5	34	6
0.11	4	1300	50	230	1.13	0.88	0.48	3.3	2.93	1.06	2.31	1.06	0.81	32.5	24	6
0.11	4	1560	60	115	2.2	0.94	0.46	3.3	3.24	1.08	2.8	1.08	0.67	6.3	10	16
0.11	4	1560	60	115	2.2	0.94	0.46	3.3	3.24	1.08	2.8	1.08	0.67	6.3	10	16
0.11	4	1560	60	230	1.16	0.99	0.41	3.3	2.93	1.06	2.31	1.06	0.67	32.5	28	6
0.15	4	1560	60	115	2.8	0.89	0.52	4	3.57	1.04	2.99	1.04	0.92	4	7	20

#### 113S 3-phase

$P_N$	$n_p$	$n_N$	$f_N$	$U_N$	$I_N$	$\cos\varphi$	$\eta$	$J_R$	$I_s/I_N$	$M_s/M_N$	$M_b/M_N$	$M_p/M_N$	$M_N$	$R_M$	$U_{SH}$ delta	$U_{SH\ star}$	$C_r$
kW		min <sup>-1</sup>	Hz	W	A			kgcm <sup>2</sup>					Nm	Ω	V DC	V DC	μF
0.04	8	720	50	230	0.64	0.58	0.27	3.9	1.53	1.59	1.59	1.49	0.53	187.5	35	-	9
0.04	8	864	60	230	0.55	0.58	0.24	3.9	1.53	1.92	1.92	1.79	0.44	187.5	30	-	6
0.04	8	720	50	400	0.37	0.58	0.27	3.9	1.53	1.59	1.59	1.49	0.53	187.5	-	60	9
0.04	8	864	60	460	0.36	0.58	0.24	3.9	1.53	1.92	1.92	1.79	0.44	187.5	-	59	6
0.11	6	865	50	230	1.05	0.67	0.39	4	2.25	2.24	2.35	2.24	1.21	30	-	-	15
0.11	6	865	50	400	0.62	0.62	0.41	4	2.03	3.14	3.35	3.14	1.21	92	-	53	15
0.11	4	1384	50	230	0.8	0.67	0.52	2.3	2.47	2.89	2.92	2.89	0.76	28	-	-	11
0.11	4	1384	50	400	0.45	0.72	0.49	2.3	3.33	2.82	2.86	2.82	0.76	83.5	-	41	11
0.11	4	1365	50	230	0.8	0.73	0.47	2.3	3.65	3.38	3.39	3.38	0.77	84	-	-	11



## Interroll Drum motor series i, S, S/A, D

### S-series product information

$P_N$	$n_p$	$n_N$	$f_N$	$U_N$	$I_N$	$\cos\varphi$	$\eta$	$J_R$	$I_s/I_N$	$M_s/M_N$	$M_b/M_N$	$M_p/M_N$	$M_N$	$R_M$	$U_{SH}$ delta	$U_{SH star}$	$C_r$
kW		$\text{min}^{-1}$	Hz	W	A			$\text{kgcm}^2$					Nm	$\Omega$	V DC	V DC	$\mu\text{F}$
0.11	4	1365	50	400	0.45	0.75	0.47	2.3	3.64	3.41	3.42	3.41	0.77	84	-	43	11
0.11	4	1635	60	230	0.75	0.73	0.5	2.3	2.72	3.18	3.19	3.18	0.64	84	-	-	9
0.11	4	1635	60	460	0.43	0.75	0.43	2.3	1.81	4.37	4.4	4.37	0.64	84	-	41	7
0.16	4	1665	60	230	0.87	0.78	0.5	3.9	1.8	2.09	2.09	2.09	0.92	64.1	22	-	9
0.16	4	1384	50	230	0.99	0.76	0.53	3.3	4.28	2.73	2.82	2.73	1.1	24.2	-	-	14
0.16	4	1348	50	400	0.57	0.76	0.53	3.3	3.85	3.29	3.39	3.29	1.13	60.5	-	39	14
0.16	4	1350	50	230	0.98	0.76	0.54	3.3	4.02	3.22	3.33	3.22	1.13	59.2	-	-	14
0.16	4	1350	50	400	0.57	0.75	0.54	3.3	3.98	3.25	3.35	3.25	1.13	59.2	-	38	14
0.16	4	1665	60	460	0.52	0.78	0.5	3.9	1.8	2.09	2.09	2.09	0.92	64.1	-	39	9
0.16	4	1610	60	230	1	0.76	0.53	3.3	4.28	3.07	2.99	3.07	0.95	59.2	-	-	12
0.16	4	1672	60	460	0.55	0.75	0.49	3.3	4.86	4.27	4.15	4.27	0.91	59.2	-	37	10
0.18	4	1383	50	230	0.98	0.76	0.55	5.6	3.71	1.76	2.08	1.76	1.24	47	18	-	15
0.18	4	1384	50	230	1	0.76	0.59	4	4	2.73	2.9	2.73	1.24	15	-	-	14
0.18	4	1384	50	400	0.62	0.76	0.55	4	3.71	3.13	3.27	3.13	1.24	47	-	33	15
0.18	4	1383	50	400	0.62	0.76	0.55	5.6	3.71	1.76	2.08	1.76	1.24	47	-	33	15
0.18	4	1355	50	230	1	0.77	0.59	4	4.37	3.54	3.74	3.54	1.27	45.5	-	-	14
0.18	4	1355	50	400	0.62	0.76	0.55	4	4.42	3.6	3.79	3.6	1.27	45.5	-	32	15
0.18	4	1665	60	575	0.47	0.73	0.53	4	3.91	3.23	3.15	3.23	1.03	88.5	-	46	6.5
0.18	4	1620	60	230	1.08	0.77	0.54	4	4.59	3.44	3.27	3.44	1.06	45.5	-	-	12
0.18	4	1675	60	460	0.62	0.76	0.48	4	5.22	4.76	4.54	4.76	1.03	45.5	-	32	11
0.33	2	2800	50	230	1.74	0.76	0.68	3.3	4.5	3.57	3.57	2.62	1.13	21.5	14	-	-
0.33	2	3420	60	230	1.43	0.73	0.68	3.3	4.5	3.2	3.2	3.2	0.92	21.5	11	-	-
0.33	2	2800	50	400	0.93	0.76	0.68	3.3	4.5	3.57	3.57	2.62	1.13	21.5	-	23	-
0.33	2	3420	60	460	0.83	0.73	0.68	3.3	4.5	3.2	3.2	3.2	0.92	21.5	-	20	-

## Interroll Drum motor series i, S, S/A, D

### S-series product information

#### Dimensions of S-series drum motor

Some dimensions are listed as "SL+". SL is the abbreviation for "shell length" (tube length). This information is located on the type plate of the drum motor (see "Type plate of S-series drum motor", page 38).

For the drum motors 80S and 113S that were manufactured before 2011, the RL dimension corresponds to the FW information used today.

- Drum motor 80S: SL = FW (RL) - 10
- Drum motor 113S: SL = FW (RL) - 22

All the length-dependent dimensions in the catalog and in this manual comply with the requirements of DIN/ISO 2768 (medium quality).



The recommended distance between the mounting brackets (EL) under consideration of the maximum thermal expansion and internal tolerances is  $EL + 2 \text{ mm}$ .

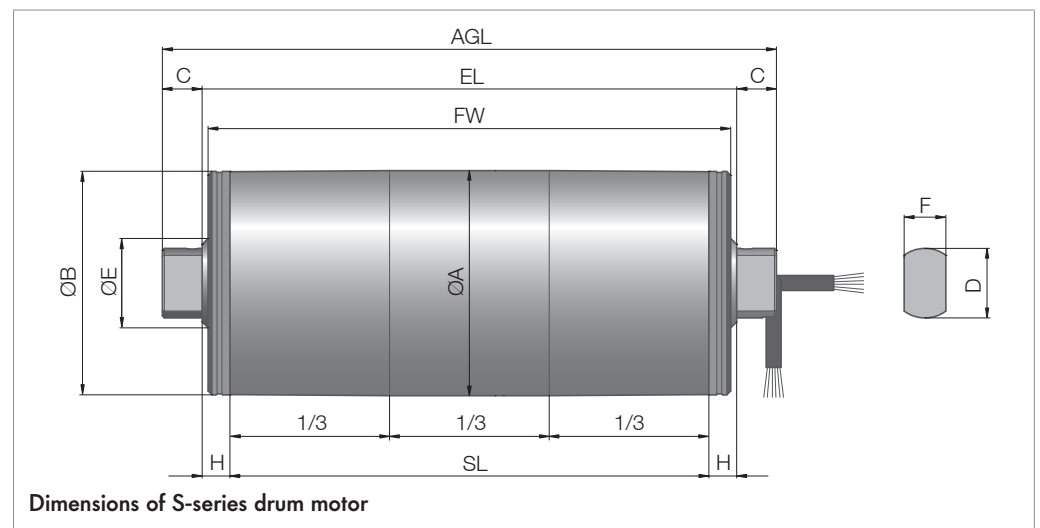

Type	A mm	B mm	C mm	D mm	E mm	F mm	H mm	FW mm	EL mm	AGL mm
80S cambered SL 260 to 602 mm	81.5	80	20	35	45	21	8	SL+10	SL+16	SL+56
80S cambered steel, center untreated and zinc-plated SL 603 to 952 mm	82.7	81	20	35	45	21	8	SL+10	SL+16	SL+56
80S cambered stainless steel, center untreated SL 603 to 952 mm	83	80	20	35	45	21	8	SL+10	SL+16	SL+56
80S cylindrical SL 260 to 602 mm	80.5	80.5	20	35	45	21	8	SL+10	SL+16	SL+56



## Interroll Drum motor series i, S, S/A, D

### S-series product information

Type	A mm	B mm	C mm	D mm	E mm	F mm	H mm	FW mm	EL mm	AGL mm
80S cylindrical, steel, outside untreated SL 603 to 952 mm	82.7	82.7	20	35	45	21	8	SL+10	SL+16	SL+56
80S cylindrical, stainless steel, outside untreated SL 603 to 952 mm	83	83	20	35	45	21	8	SL+10	SL+16	SL+56
113S cambered	113.3	112.4	20	35	45	21	14	SL+22	SL+28	SL+68
113S cylindrical	113.0	113.0	20	35	45	21	14	SL+22	SL+28	SL+68

## Interroll Drum motor series i, S, S/A, D

### S-series product information

#### Connection diagrams for the S-series

This instruction manual lists only standard connection diagrams. For other connection types, the connection diagram is supplied separately with the drum motor.

Abbreviations see "List of abbreviations", page 108

#### Cable connections

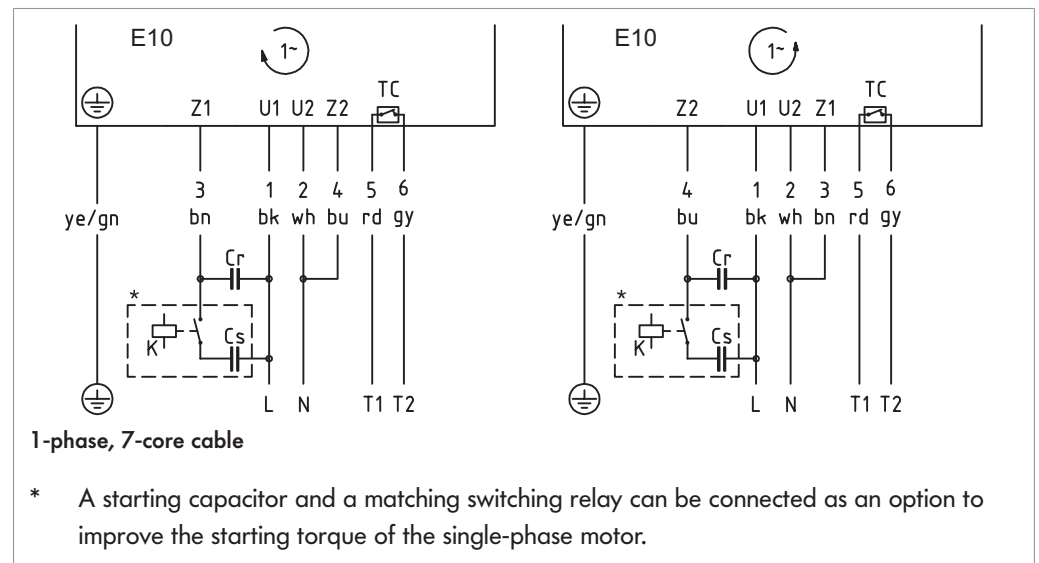
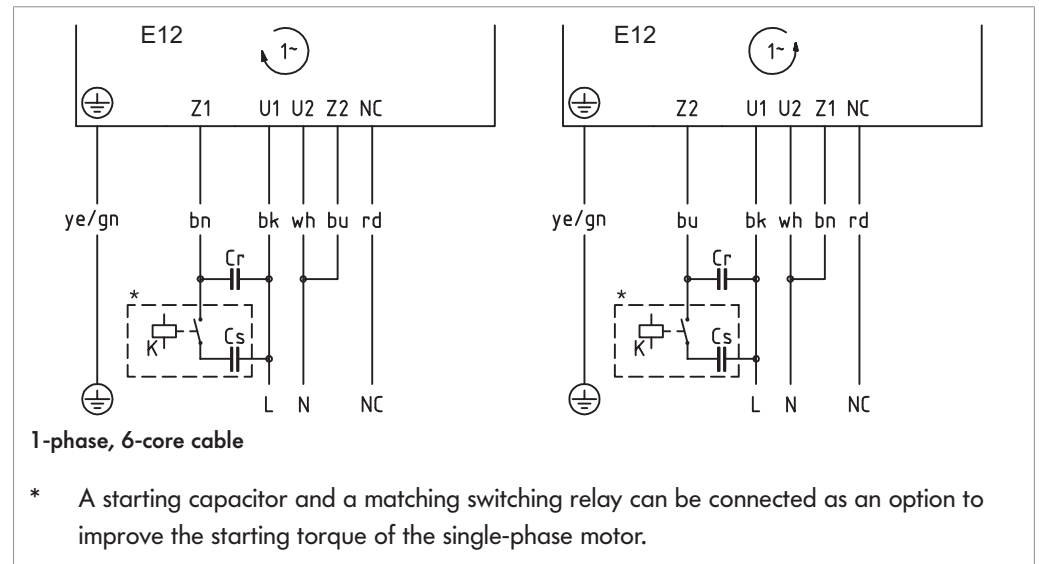

## Interroll Drum motor series i, S, S/A, D

### S-series product information

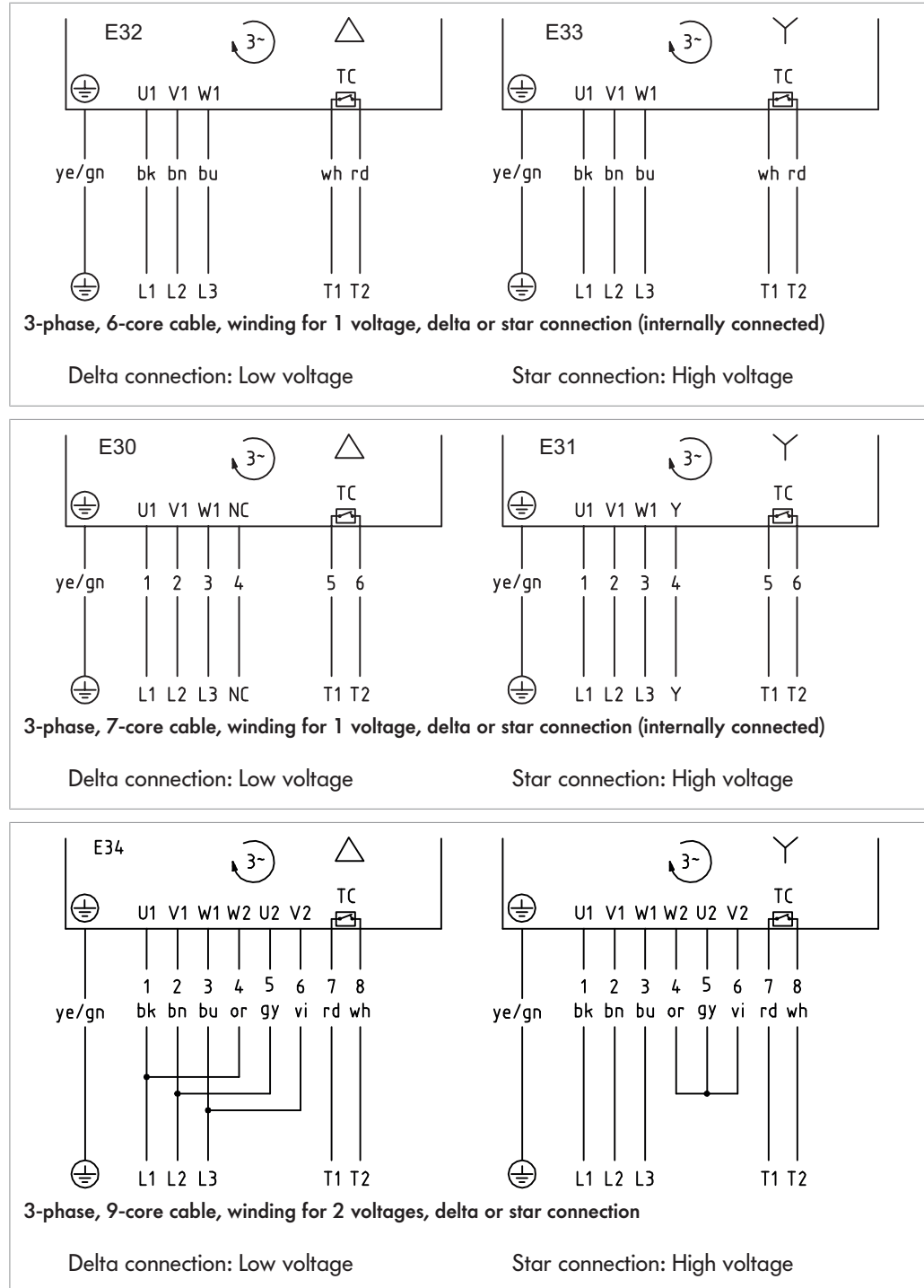

## Interroll Drum motor series i, S, S/A, D

### S-series product information

#### Connections in the terminal box

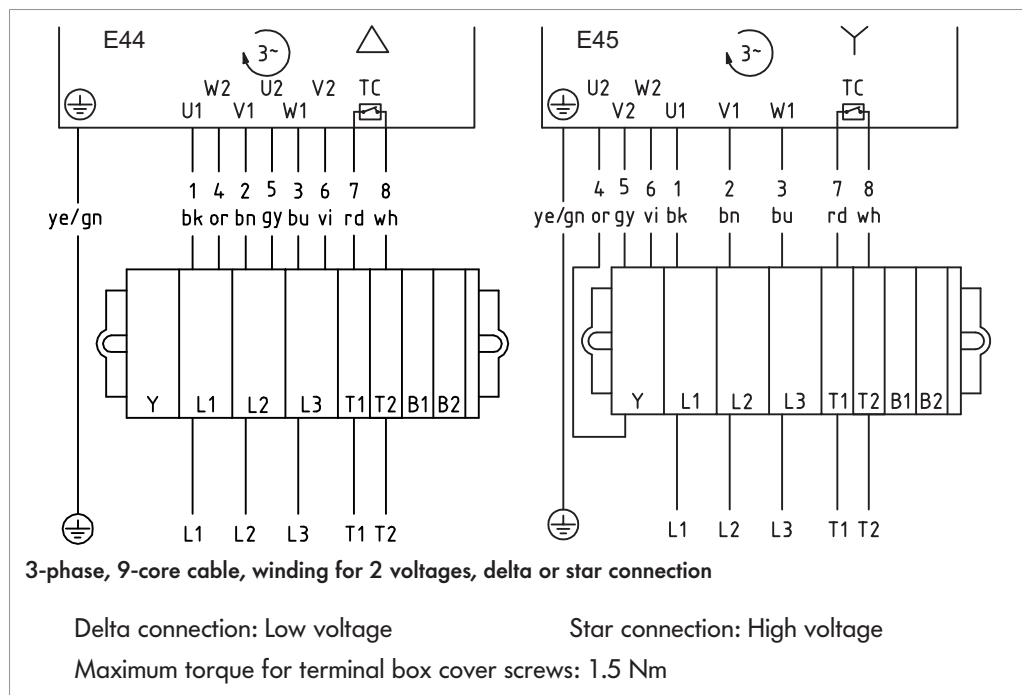
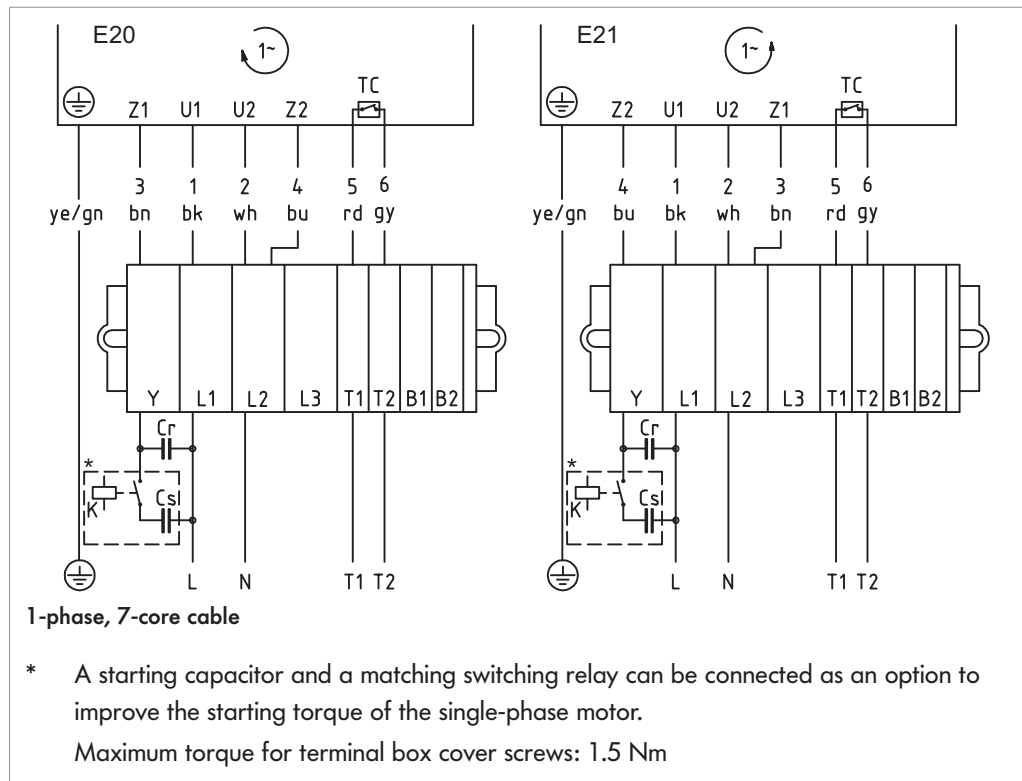

## S/A-series product information

### Type plate of S/A-series drum motor

The information on the type plate of the drum motor is intended for its identification. The type plate is used to be able to properly use the drum motor.

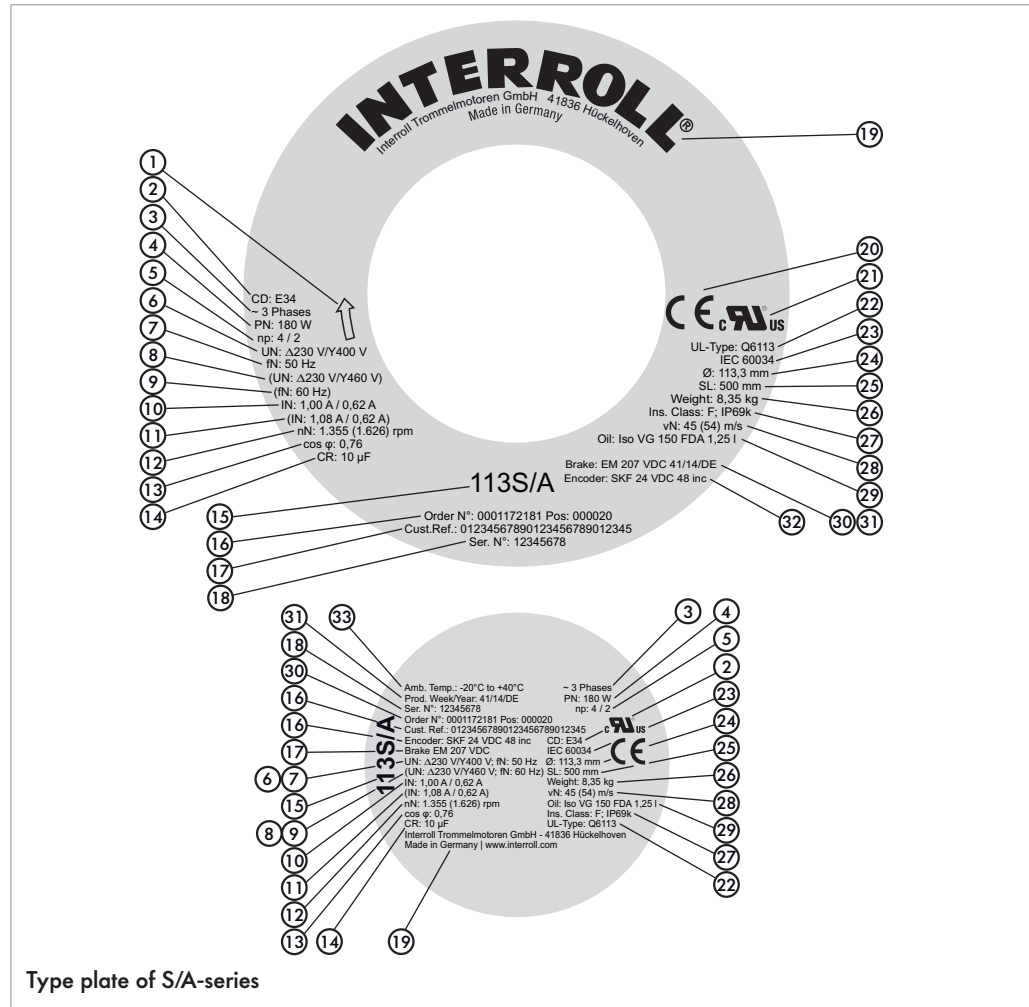

- |   |                               |    |                                       |
|---|-------------------------------|----|---------------------------------------|
| 1 | Direction of travel           | 18 | Serial number                         |
| 2 | Connection diagram number     | 19 | Manufacturer / manufacturing location |
| 3 | Number of phases              | 20 | CE mark                               |
| 4 | Rated power                   | 21 | UL mark                               |
| 5 | Number of poles               | 22 | Type of UL standard                   |
| 6 | Rated voltage                 | 23 | Standard for drum motors              |
| 7 | Rated frequency               | 24 | Max. diameter of tube                 |
| 8 | (rated voltage) <sup>1)</sup> | 25 | Roller or tube length                 |



## Interroll Drum motor series i, S, S/A, D

### S/A-series product information

9 (rated frequency) <sup>1)</sup>	26 Weight
10 Rated current	27 Insulation class and IP rating
11 (rated current) <sup>1)</sup>	28 Circumferential speed of tube
12 Rated speed of rotor <sup>1)</sup>	29 Oil type
13 Power factor	30 Brake data
14 Run capacitor	31 Date of manufacture (week/year/country)
15 Type	32 Encoder data
16 Part number	33 Permissible ambient temperature
17 Customer part number	

<sup>1)</sup> The value depends on the voltage used. All values in parentheses refer to the rated voltage in parentheses.

### Electrical data of S/A-series

Abbreviations see "List of abbreviations", page 108

#### 113S/A 1-phase

$P_N$	$n_p$	$n_N$	$f_N$	$U_N$	$I_N$	$\cos\varphi$	$\eta$	$J_R$	$I_s/I_N$	$M_s/M_N$	$M_B/M_N$	$M_p/M_N$	$M_N$	$R_M$	$C_r$
kW		$\text{min}^{-1}$	Hz	W	A			$\text{kgcm}^2$					Nm	$\Omega$	$\mu\text{F}$
0.25	4	1360	60	115	4.34	0.95	0.53	7.2	2.07	1.31	1.31	1.31	1.76	0	40
0.25	4	1360	50	230	2.4	0.97	0.47	7.2	1.25	1.1	1.1	1.1	1.76	12.7	12

#### 113S/A 3-phase

$P_N$	$n_p$	$n_N$	$f_N$	$U_N$	$I_N$	$\cos\varphi$	$\eta$	$J_R$	$I_s/I_N$	$M_s/M_N$	$M_B/M_N$	$M_p/M_N$	$M_N$	$R_M$	$U_{SH}$ delta	$U_{SH\ star}$	$C_r$
kW		$\text{min}^{-1}$	Hz	W	A			$\text{kgcm}^2$					Nm	$\Omega$	V DC	V DC	$\mu\text{F}$
0.37	4	1400	50	230	2.1	0.71	0.63	7.4	3.9	2.24	2.24	2.24	2.52	21.4	16	-	-
0.37	4	1700	60	230	1.7	0.78	0.54	7.4	4.8	2.67	2.67	2.67	2.08	21.4	14	-	19
0.37	4	1360	60	330	1.54	0.66	0.69	7.4	3.9	2.24	2.24	2.24	2.6	34	-	17	11
0.37	4	1400	50	400	1.2	0.71	0.63	7.4	3.9	2.24	2.24	2.24	2.52	21.4	-	27	-
0.37	4	1700	60	460	1.1	0.78	0.54	7.4	4.8	2.67	2.67	2.67	2.08	21.4	-	28	19
0.37	4	1360	60	575	0.82	0.66	0.69	7.4	3.9	2.24	2.24	2.24	2.6	34	-	28	11

## Interroll Drum motor series i, S, S/A, D

### S/A-series product information

#### Dimensions of S/A-series drum motor

Some dimensions are listed as "SL+". SL is the abbreviation for "shell length" (tube length). This dimension is indicated on the type plate of the drum motor (see "Type plate of S/A-series drum motor", page 48).

All the length-dependent dimensions in the catalog and in this manual comply with the requirements of DIN/ISO 2768 (medium quality).



The recommended distance between the mounting brackets (EL) under consideration of the maximum thermal expansion and internal tolerances is  $EL + 2 \text{ mm}$ .

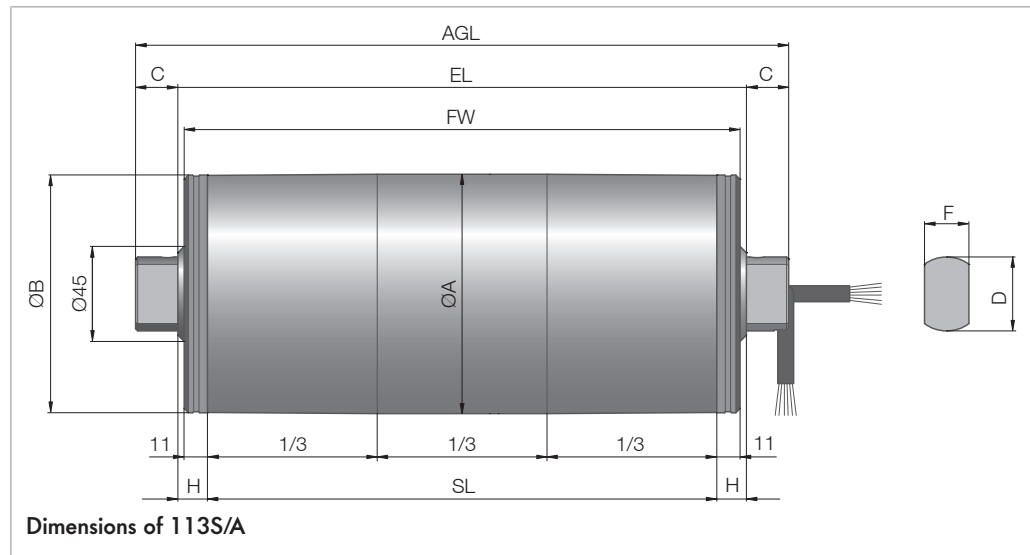

Type	A mm	B mm	C mm	D mm	F mm	H mm	EL mm	AGL mm
113 S/A solid axle version, cambered	113.3	112.4	25	25	20	14	SL+28	SL+78
113 S/A solid axle version, cylindrical	113	113	25	25	20	14	SL+28	SL+78
113 S/A shaft-end cap version, cambered	113.3	112.4	20	35	21	14	SL+28	SL+68
113 S/A shaft-end cap version, cylindrical	113	113	20	35	21	14	SL+28	SL+68

## Interroll Drum motor series i, S, S/A, D

### S/A-series product information

### Connection diagrams for the S/A-series

This instruction manual lists only standard connection diagrams. For other connection types, the connection diagram is supplied separately with the drum motor.

Abbreviations see "List of abbreviations", page 108

#### Cable connections

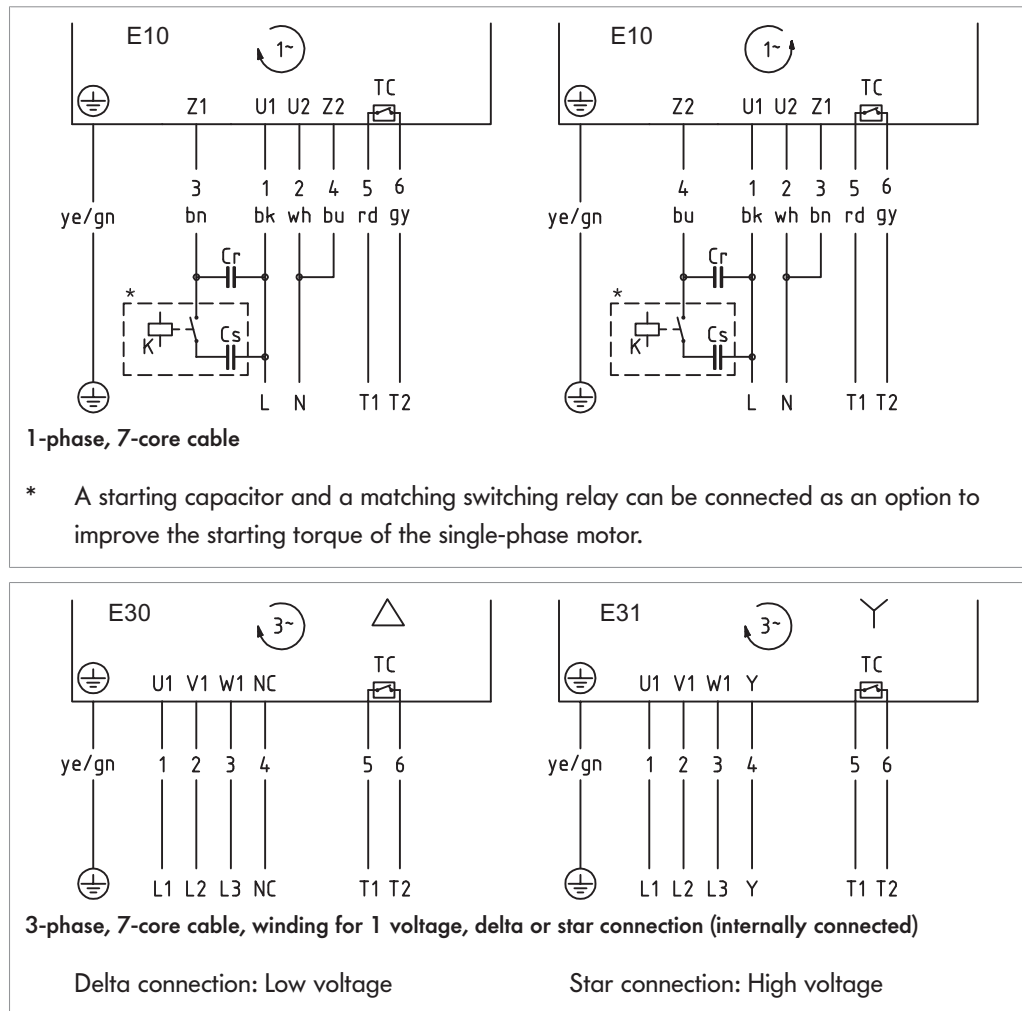

## Interroll Drum motor series i, S, S/A, D

### S/A-series product information

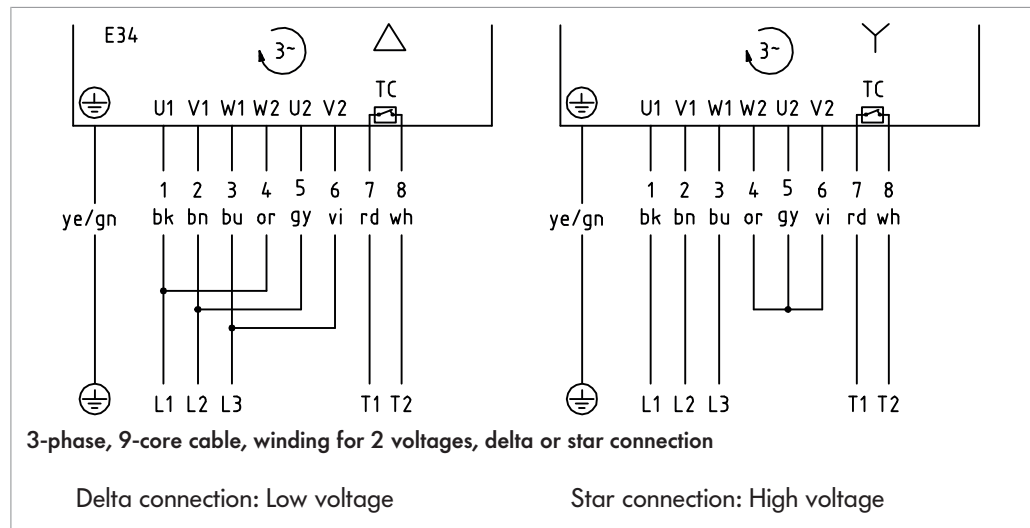
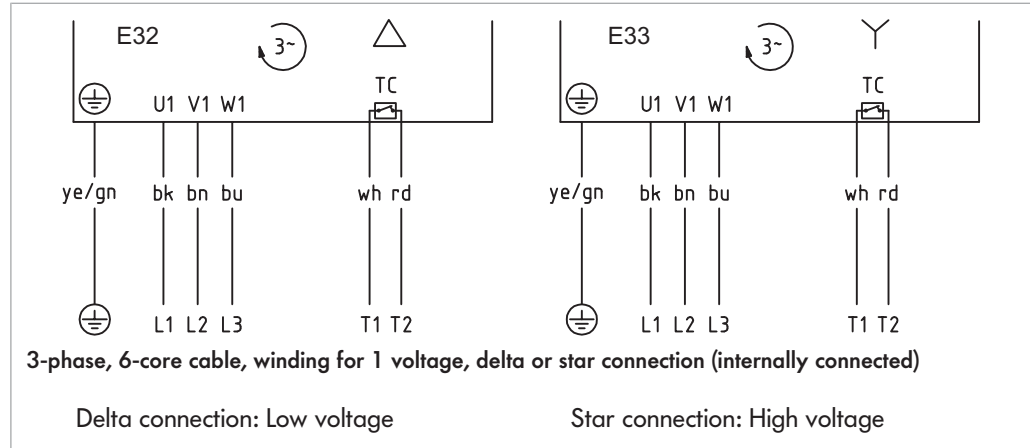

## Interroll Drum motor series i, S, S/A, D

### S/A-series product information

#### Connections in the terminal box

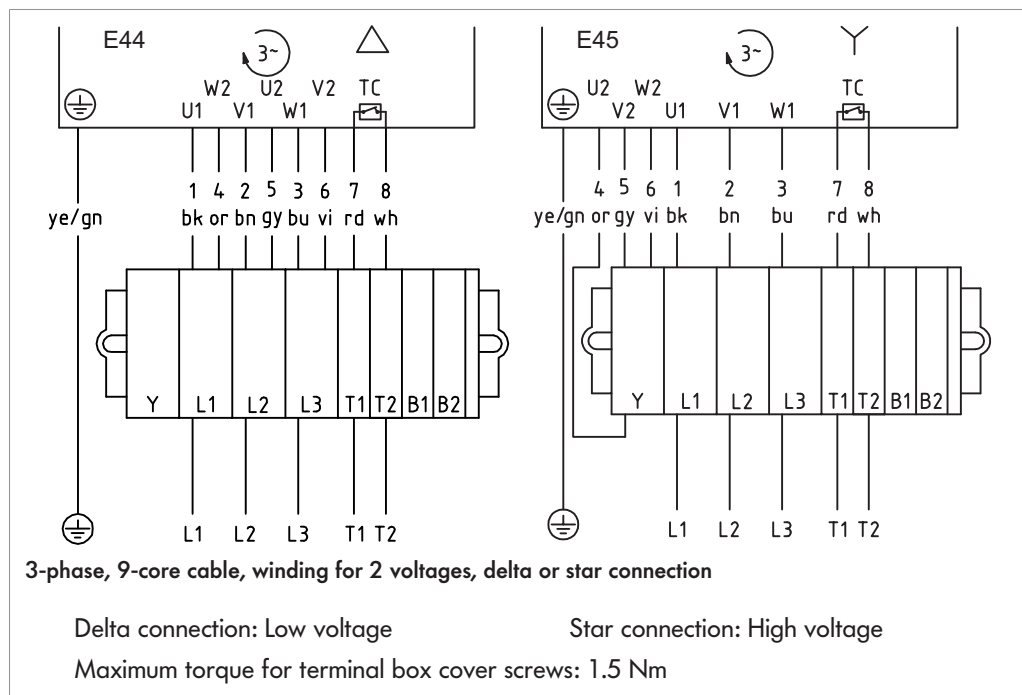
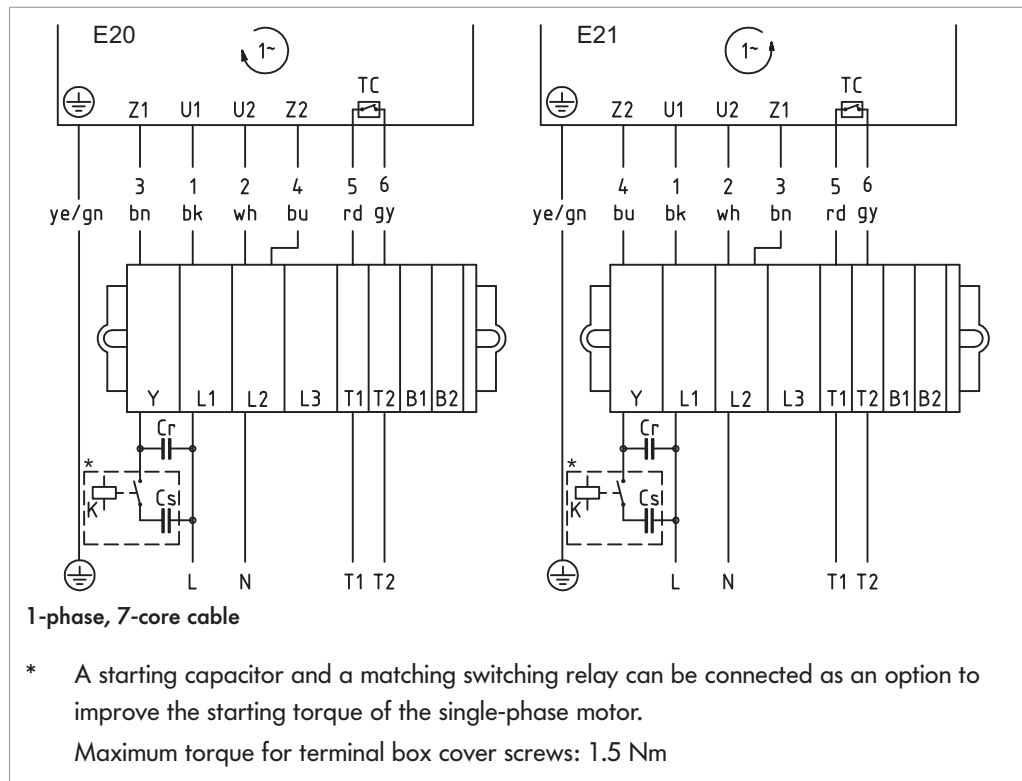

## D-series product information

### Type plate of D-series drum motor

The information on the type plate of the drum motor is intended for its identification. This is the only way for the drum motor to be used properly.

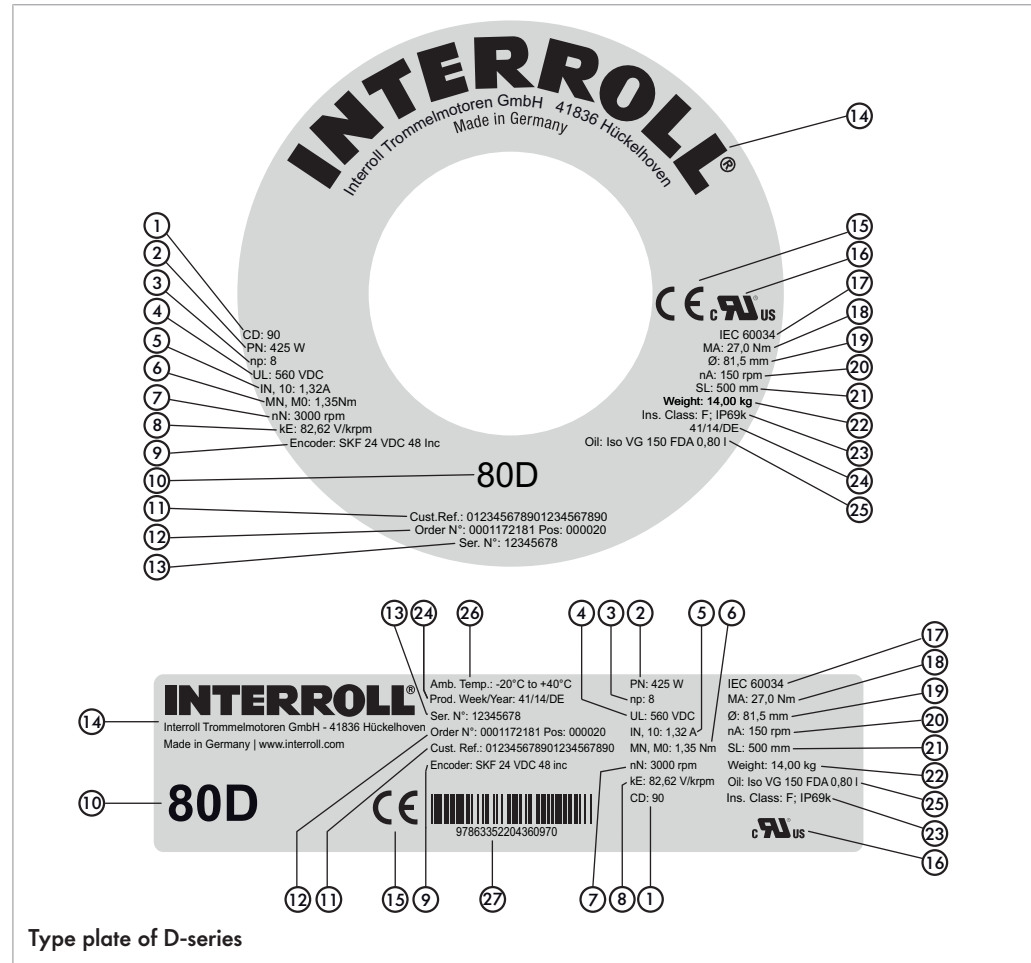

- |   |                              |    |                                |
|---|------------------------------|----|--------------------------------|
| 1 | Connection diagram number    | 15 | CE mark                        |
| 2 | Rated power                  | 16 | UL mark                        |
| 3 | Number of poles              | 17 | Standard for drum motors       |
| 4 | Intermediate circuit voltage | 18 | Rated torque of drum motor     |
| 5 | Rated current                | 19 | Max. diameter of tube          |
| 6 | Rated torque of rotor        | 20 | Rated speed of tube            |
| 7 | Rated speed of rotor         | 21 | Roller or tube length          |
| 8 | Induced motor voltage        | 22 | Weight                         |
| 9 | Encoder data                 | 23 | Insulation class and IP rating |

## Interroll Drum motor series i, S, S/A, D

### D-series product information

10 Type	24 Date of manufacture (week/year/country)
11 Customer part number	25 Oil type
12 Part number	26 Permissible ambient temperature
13 Serial number	27 EAN code
14 Manufacturer / manufacturing location	

### Electrical data of D-series

Abbreviations see "List of abbreviations", page 108

Number of poles	8 (4 pole pairs)
Rated speed of rotor	3000 1/min
Rated frequency	200 Hz
Winding connection	Star
Thermal protection type	TC 130 °C

$P_N$	$U_N$	$I_N$	$I_0$	$I_{max}$	$\eta$	$J_R$	$M_N$	$M_0$	$M_{max}$	$R_M$	$L_{sd}$	$L_{sq}$	$k_e$	$T_e$	$k_{TN}$	$U_{SH}$
kW	V	A	A	A		kgcm <sup>2</sup>	Nm	Nm	Nm	$\Omega$	mH	mH	V/krpm	ms	Nm/A	V
0.08	400	0.26	0.26	0.78	0.83	0.14	0.25	0.25	0.76	62.54	130.7	138.0	72.23	4.41	0.98	36
0.08	230	0.45	0.45	1.34	0.85	0.14	0.25	0.25	0.76	21.62	45.6	53.7	41.57	4.97	0.57	25
0.11	400	0.29	0.29	0.86	0.87	0.28	0.35	0.35	1.05	29.06	81.9	94.1	83.09	6.48	1.22	32
0.11	230	0.48	0.48	1.44	0.86	0.28	0.35	0.35	1.05	10.2	27.8	29.3	47.46	5.75	0.73	19
0.145	230	0.81	0.81	2.43	0.85	0.14	0.46	0.46	1.38	21.6	45.60	53.70	41.57	4.97	0.57	25
0.145	400	0.47	0.47	1.41	0.83	0.14	0.46	0.46	1.38	62.5	130.7	138.0	72.23	4.41	0.98	36
0.18	400	0.56	0.56	1.69	0.86	0.42	0.57	0.57	1.72	17.6	49.8	59	80.80	6.70	1.02	33
0.18	230	0.97	0.97	2.91	0.87	0.42	0.57	0.57	1.72	5.66	16.26	19.42	45.81	6.86	0.59	19
0.298	230	1.30	1.30	3.90	0.86	0.28	0.95	0.95	2.85	10.2	27.80	29.30	47.46	5.75	0.73	19
0.298	400	0.78	0.78	2.34	0.87	0.28	0.95	0.95	2.85	29.1	81.90	94.10	83.09	6.48	1.22	32
0.425	230	2.30	2.30	6.90	0.87	0.42	1.35	1.35	4.05	5.66	16.26	19.42	45.81	6.86	0.59	19
0.425	400	1.32	1.32	3.96	0.86	0.42	1.35	1.35	4.05	17.6	49.80	59.00	80.80	6.70	1.02	33

Number of poles	6 (3 pole pairs)
Rated speed of rotor	4500 1/min
Rated frequency	225 Hz
Winding connection	Star
Thermal protection type	TC 130 °C



## Interroll Drum motor series i, S, S/A, D

### D-series product information

$P_N$	$U_N$	$I_N$	$I_0$	$I_{max}$	$\eta$	$J_R$	$M_N$	$M_0$	$M_{max}$	$R_M$	$L_{sd}$	$L_{sq}$	$k_e$	$T_e$	$k_{TN}$	$U_{SH}$
kW	V	A	A	A		kgcm <sup>2</sup>	Nm	Nm	Nm	$\Omega$	mH	mH	V/krpm	ms	Nm/A	V
0.45	400	1.62	1.62	4.86	0.87	0.42	0.95	0.95	2.86	5.66	16.26	19.42	45.81	6.86	0.59	13.7
0.67	400	1.48	1.48	4.17	0.88	0.72	1.42	1.42	4	4.85	13.2	15.5	65.7	6.39	0.96	10.8
0.7	400	2.52	2.52	6.78	0.87	0.42	1.49	1.49	4	5.66	16.26	19.42	45.81	6.86	0.59	21.4
1.1	400	2.31	2.31	3.97	0.87	0.72	2.33	2.33	4	4.85	13.2	15.5	65.7	6.39	1.01	16.8

Averaged inductance:  $L_{sm} = (L_{sd} + L_{sq}) / 2$



## Interroll Drum motor series i, S, S/A, D

### D-series product information

#### Dimensions of D-series drum motor

Some dimensions are listed as "SL+". SL is the abbreviation for "shell length" (tube length). This dimension is indicated on the type plate of the drum motor (see "Type plate of D-series drum motor", page 54).

All length-dependent dimensions in the catalog and in this manual comply with the requirements of DIN/ISO 2768 (medium quality).



The recommended distance between the mounting brackets (EL) while taking into account the maximum thermal expansion and internal tolerances is  $EL + 2$  mm.

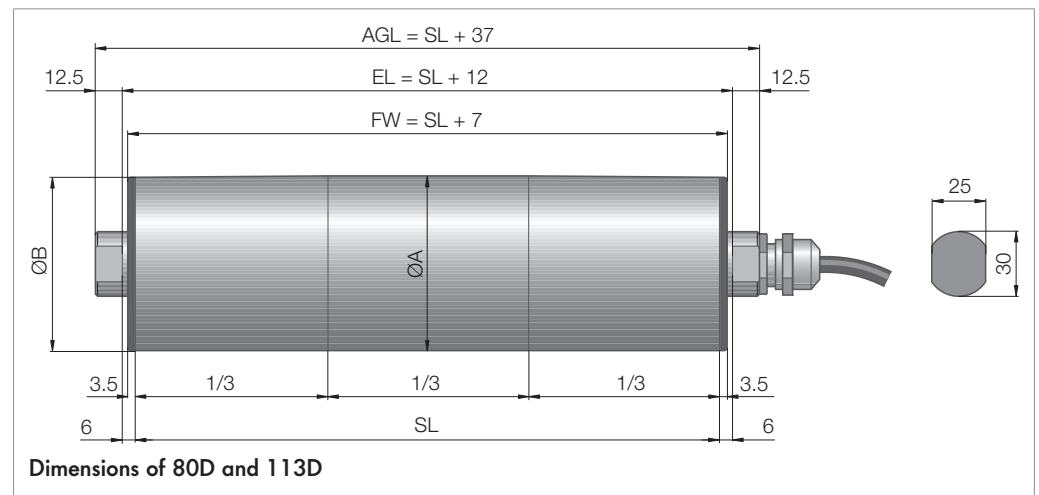

Type	A mm	B mm
80D cambered	81.5	80.5
80D cylindrical	81.0	81.0
80D cylindrical with key	81.7	81.7
113D cambered	113.5	112.0
113D cylindrical	112.0	112.0
113D cylindrical with key	113.0	113.0

#### Connection diagrams for the D-series

This instruction manual lists only standard connection diagrams. For other connection types, the connection diagram is supplied separately with the drum motor.

### NOTICE

#### Damage of the drum motor from incorrect connection

- ▶ Do not connect drum motors of the D-series directly to the supply system; instead, operate them via a suitable frequency inverter.

## Interroll Drum motor series i, S, S/A, D

### D-series product information

Abbreviations see "List of abbreviations", page 108

#### Cable connections

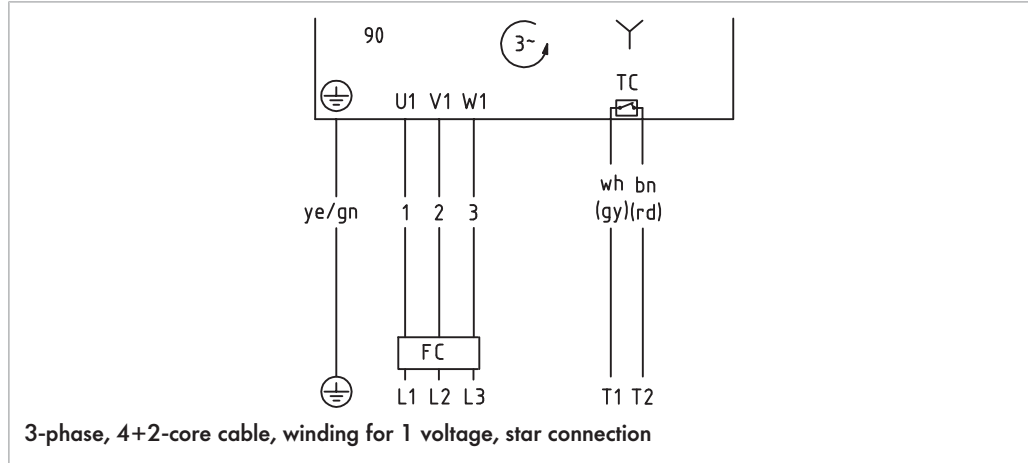

#### Encoder connection

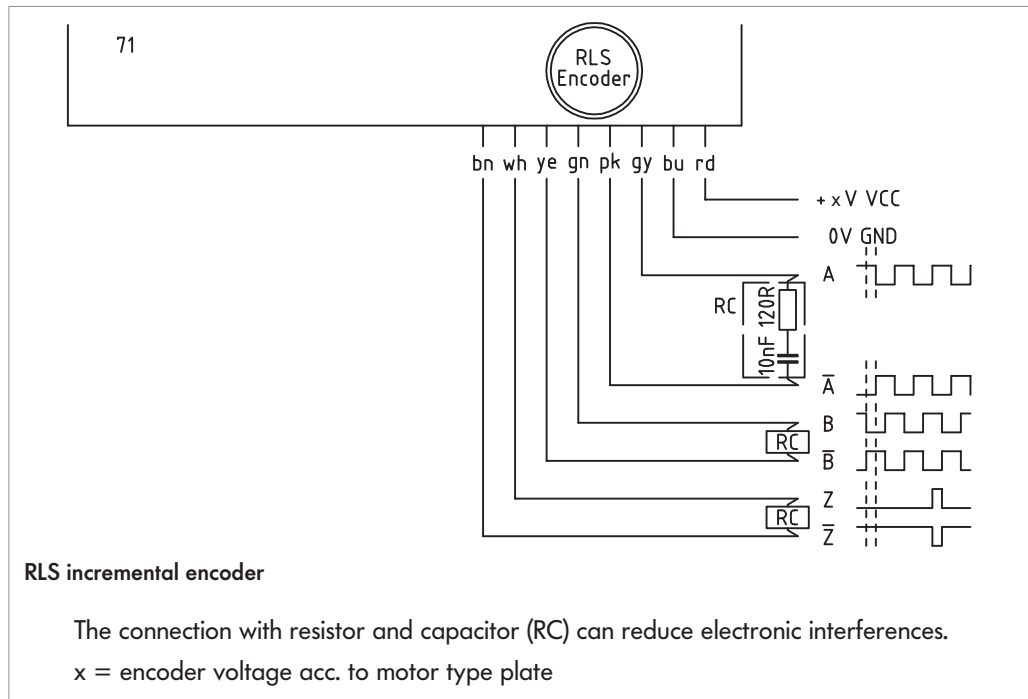

# Interroll Drum motor series i, S, S/A, D

## D-series product information

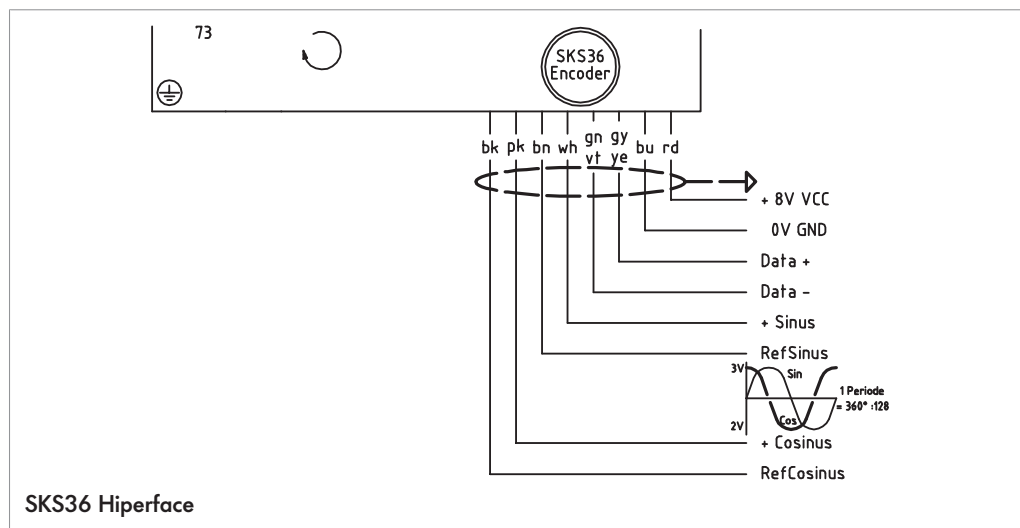
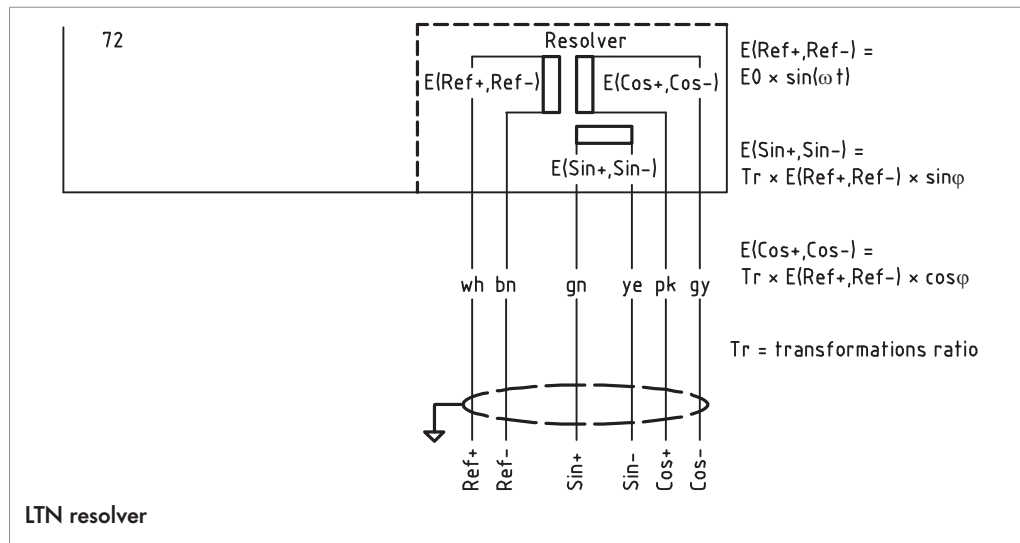

### Options and accessories

#### Electromagnetic brake for the i-series

M	Rated continuous torque of brake
$J_{BR}$	Brake moment of inertia
$U_{BR}$	Rated voltage
$P_{BR}$	Rated power
$I_{BR}$	Rated current
$t_{pick\ up}$	Brake response time
$t_{fall\ delay\ AC}$	Brake release switching time with AC-based switching
$t_{fall\ delay\ DC}$	Brake release switching time with DC-based switching

Motor	Brake size	M	$J_{BR}$	$P_{BR}$	$U_{BR}$	$I_{BR}$	$t_{pick\ up}$	$t_{fall\ delay\ AC}$	$t_{fall\ delay\ DC}$
		Nm	kgcm <sup>2</sup>	W	V DC	A	ms	ms	ms
80i	2	0.7	0.04	12	24	0.50	20	80	13
					104	0.12			
113i	3	1.5	0.08	17	24	0.71	25	120	20
					104	0.16			
					180	0.09			
138i	4	2.9	0.23	24	24	1.00	30	200	23
					104	0.23			
					180	0.13			
					207	0.12			
165 / 217i*	5	5.95	0.68	33	24	1.38	40	260	46
					104	0.32			
					207	0.16			
217i		12		50	104	0.48	60	500	60
					207	0.24			

217i\* see "165i and 217i\* 3-phase", page 25

## Interroll Drum motor series i, S, S/A, D

### Options and accessories

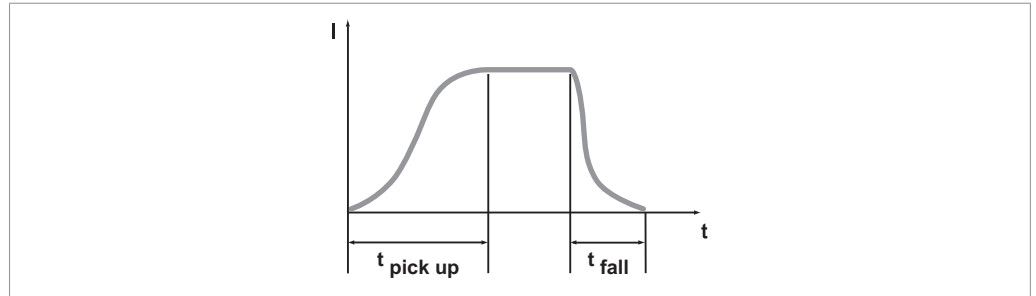

AC-switching (The input voltage at terminals 1 and 2 of the brake rectifier is switched.)	Long fall delay Brake voltage approx. 1 V Brake is softly applied
DC-switching (The output voltage is switched via terminals 3 and 4 of the brake rectifier.) The switching contact must be suitable for high-voltage peaks and contact-breaking sparks resulting from with DC-switching.	Short fall delay Brake voltage approx. 500 V Brake is abruptly applied
Electronic rectifier	Behavior similar to DC-switching

Overexcitation voltage = 2 x rated operating voltage,  $t_{pick\ up}$  is halved.

Standard 104 V DC, available off-the-shelf



The braking torque at the drum tube corresponds to the gear ratio of the motor times the braking torque listed in the table above. For safety purposes, 25 % reserve have to be figured into the dimensioning of the brake. The brake is not a safety holding brake. Since there are motor combinations that feature a higher torque than braking torque, it is always recommended to use the greatest possible gear ratio for the use of a brake.

All brakes are dimensioned for start/stop operation.

The rise and fall delays of the brakes can vary significantly depending on the following factors:

- Oil type and viscosity
- Oil quantity in the drum motor
- Ambient temperature
- Internal operating temperature of the motor

## Interroll Drum motor series i, S, S/A, D

### Options and accessories

#### Brake rectifiers for i-series

Input voltage V AC	Brake voltage V DC	Starting voltage V DC	Holding voltage V DC	Type	Application	Reference number
115	104	104	52	Fast-switching rectifier	Start/stop applications or continuous operation	61011343
230	207	207	104	Fast-switching rectifier	Start/stop applications or continuous operation	61011343
230	104	104	104	One-way half-wave rectifier and bridge rectifier	Start/stop applications or continuous operation	1001440
230	104	190	52	Phase rectifier	Continuous operation	1001442
400	104	180	104	Multi-switch	Continuous operation	1003326
460	104	180	104	Multi-switch	Continuous operation	1003326
460	207	207	207	One-way half-wave rectifier and bridge rectifier	Start/stop applications or continuous operation	1001441

The use of a fast-acting or phase rectifier allows saving energy since the holding voltage is lower than the rated braking voltage.

#### Brake rectifier connections

Interroll recommends installing a switch between 3 and 4 for a faster release of the brake.

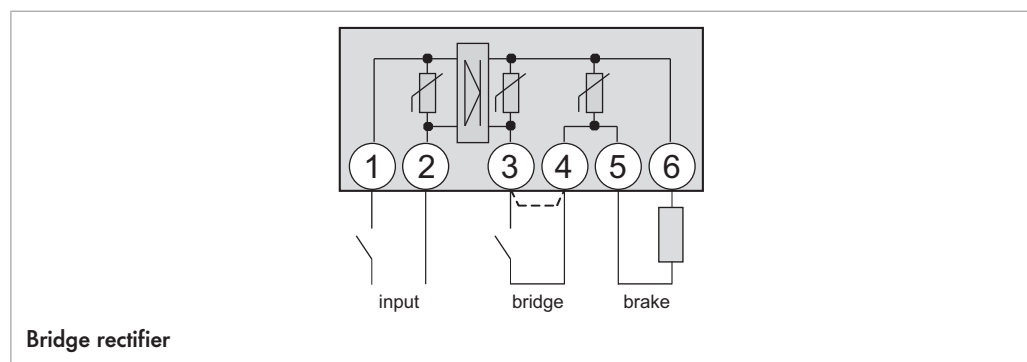
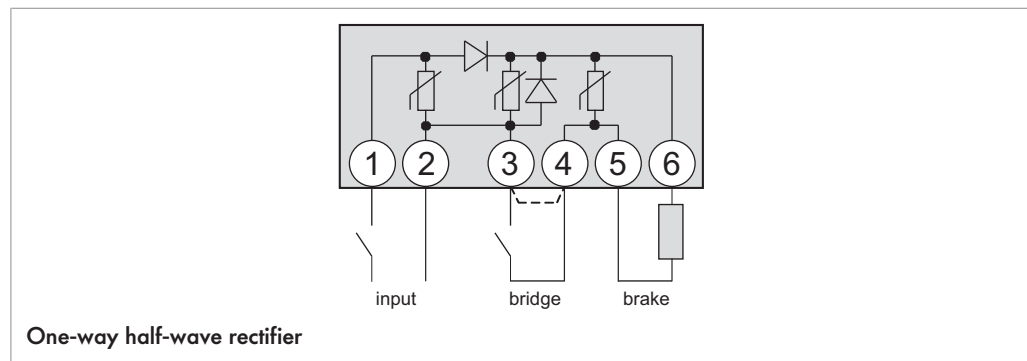

## Interroll Drum motor series i, S, S/A, D

### Options and accessories

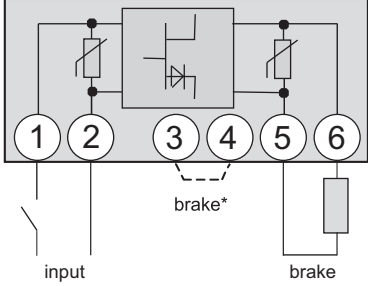

The diagram shows a phase rectifier circuit with six terminals labeled 1 through 6. Terminals 1 and 2 are connected to an AC input switch. Terminals 3 and 4 are connected to a bridge rectifier. Terminals 5 and 6 are connected to a brake resistor. A dashed line labeled 'brake\*' indicates a connection between terminals 3 and 4.

**Phase rectifier**

Maximum switching frequency = 2 cycles/second

\* Connection 3 & 4 interrupts the DC circuit and extends the fall delay

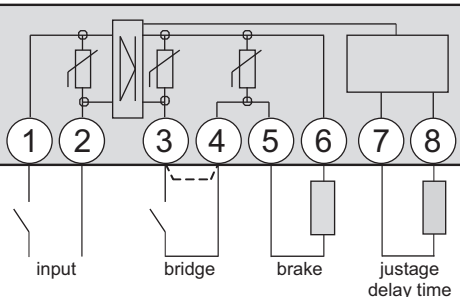

The diagram shows a fast-acting rectifier circuit with eight terminals labeled 1 through 8. Terminals 1 and 2 are connected to an AC input switch. Terminals 3 and 4 are connected to a bridge rectifier. Terminals 5 and 6 are connected to a brake resistor. Terminals 7 and 8 are connected to a justage delay time component. A dashed line labeled 'bridge' indicates a connection between terminals 3 and 4.

**Fast-acting rectifier**

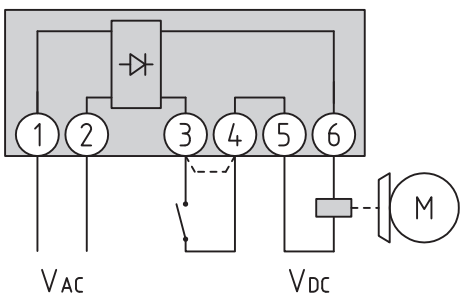

The diagram shows a multi-switch rectifier circuit with six terminals labeled 1 through 6. Terminals 1 and 2 are connected to an AC input switch labeled V<sub>AC</sub>. Terminals 3 and 4 are connected to a bridge rectifier. Terminals 5 and 6 are connected to a DC output labeled V<sub>DC</sub>, which is connected to a motor symbol 'M'. A dashed line indicates a connection between terminals 3 and 4.

**Multi-switch rectifier**

## Interroll Drum motor series i, S, S/A, D

### Options and accessories

#### Brake rectifier dimensions

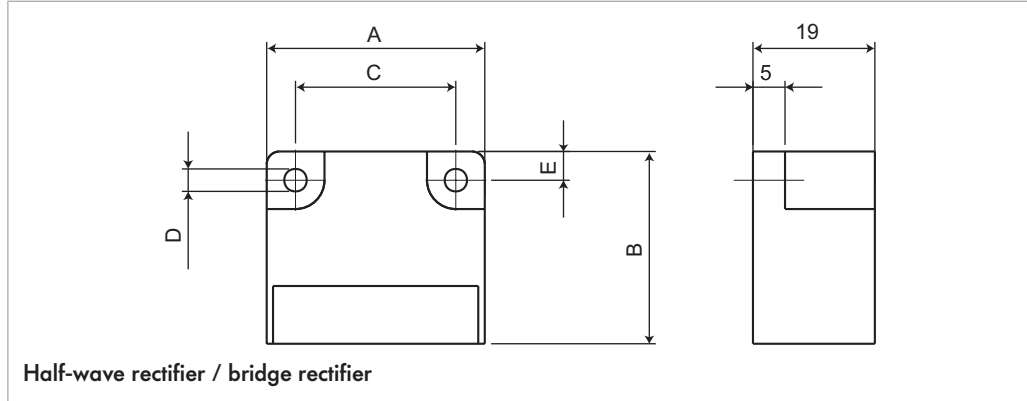

Reference number	A mm	B mm	C mm	D mm	E mm
1001440	34	30	25	3.5	4.5
1001441	64	30	54	4.5	5

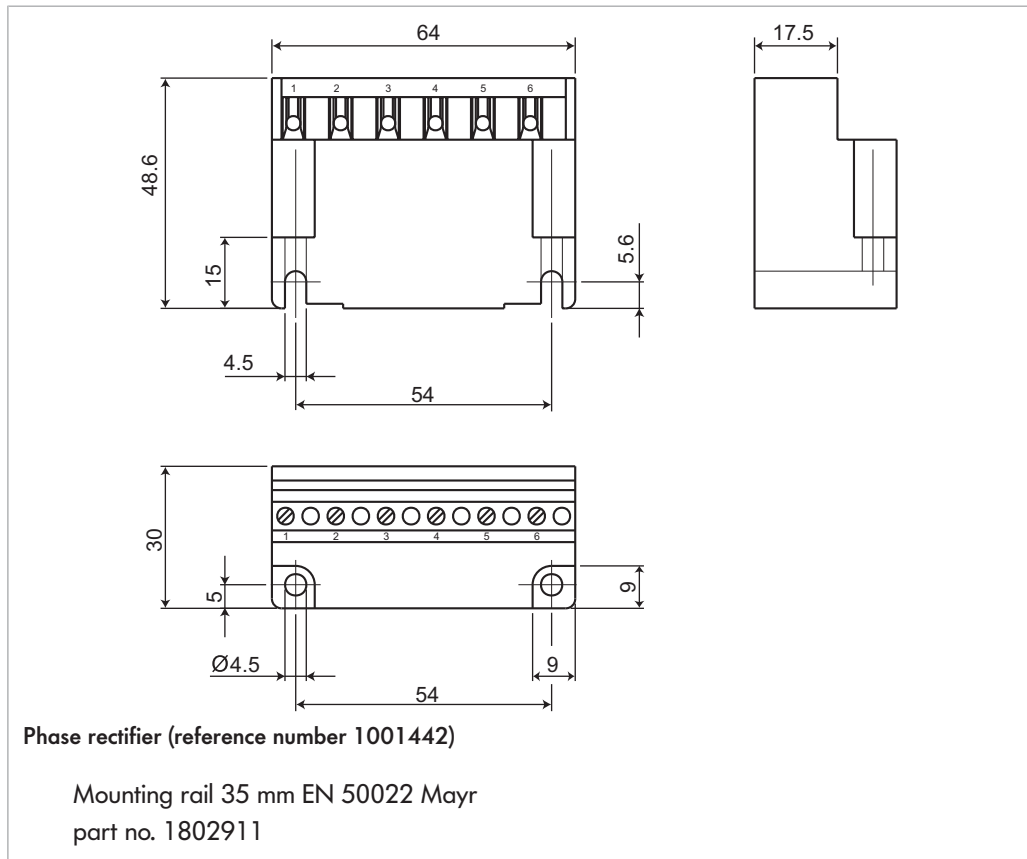



## Interroll Drum motor series i, S, S/A, D

### Options and accessories

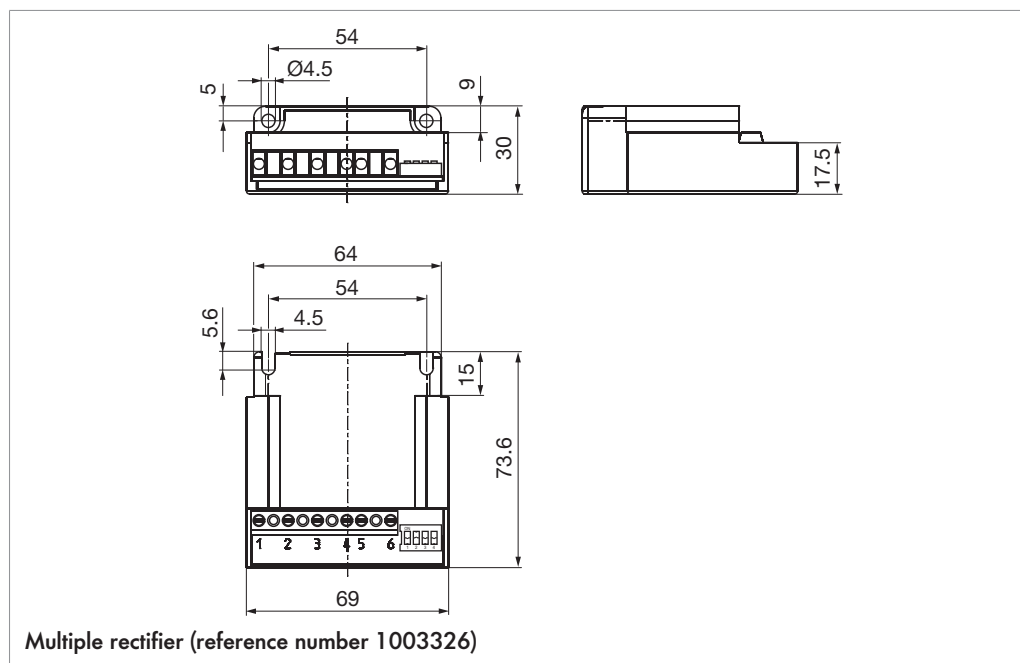
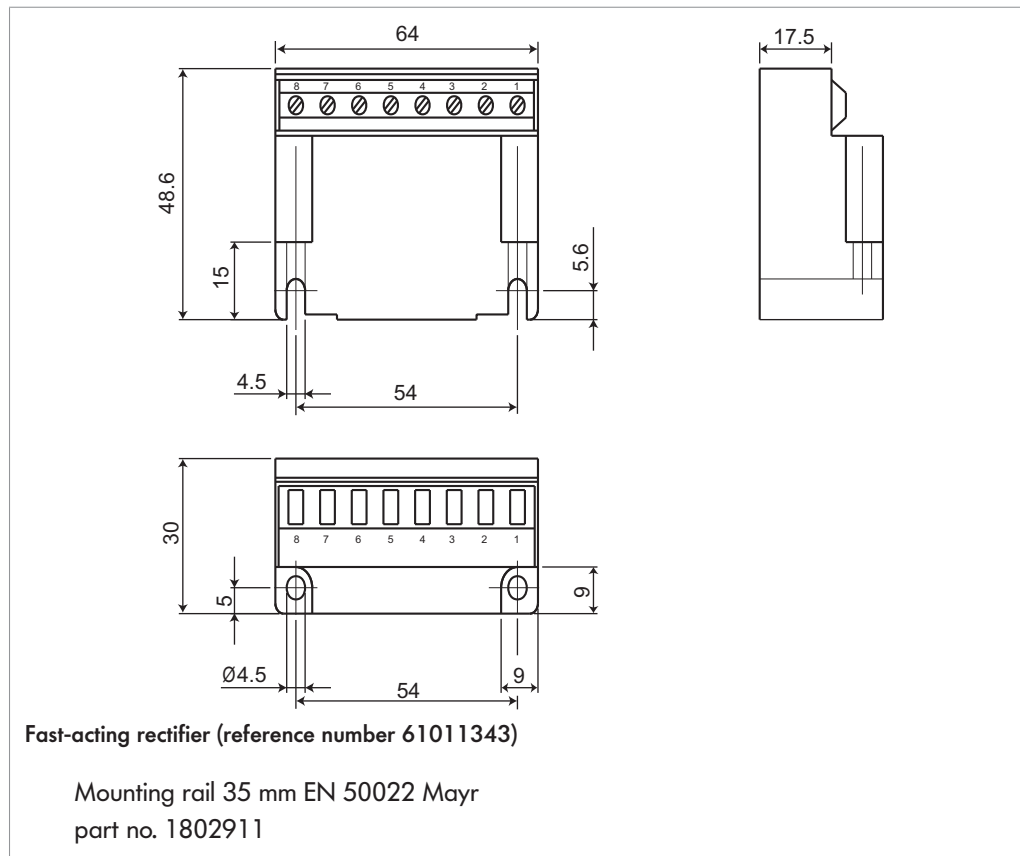

## Interroll Drum motor series i, S, S/A, D

### Options and accessories

### Asynchronous drum motors with frequency inverters

Torque dependent on input frequency

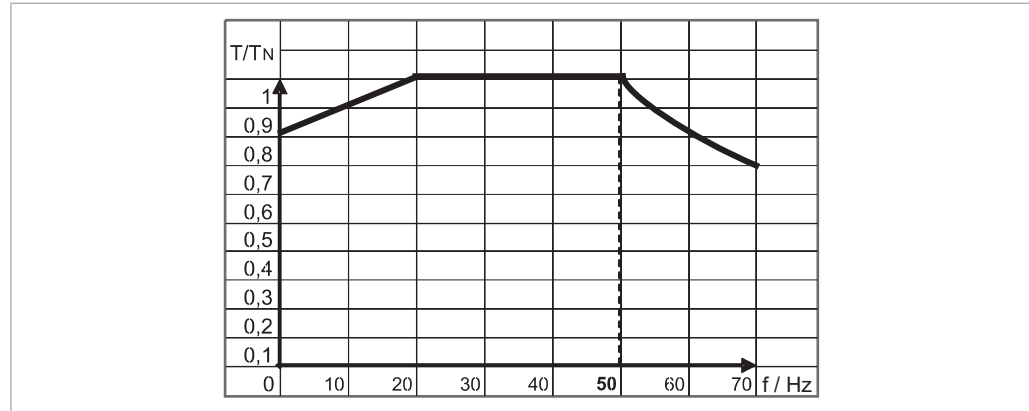

Operating frequency [Hz]	5	10	15	20	25	30-50	55	60	65	70	75	80
<b>Available motor torque in %</b>												
<b>Rated motor frequency</b>	<b>50 Hz</b>	80	85	90	95	100	100	91	83	77	71	
<b>Rated motor frequency</b>	<b>60 Hz</b>	75	80	85	90	95	100	100	100	92	86	80

Value 1: Based on a rated motor frequency of 50 Hz (50-Hz motors should be operated only up to 70 Hz in the speed range under field control.)

Value 2: Based on a rated motor frequency of 60 Hz (60-Hz motors should be operated only up to 80 Hz in the speed range under field control.)

The torque dependency depicted in the figure above is expressed as  $P = T \times \omega$ . With a reduced operating frequency of below 20/24 Hz, the motor torque is reduced by changing heat dissipation conditions. The power loss dissipation is a result of the oil quantity, in contrast to standard ventilated motors. For frequencies starting at 80 ... 85 / 95 100 Hz, the curve for the output torque does not have a hyperbolic shape, but is instead replaced with a quadratic function which is the result of the effect of the pull-out torque and the voltage. The output/frequency characteristics of most frequency inverters supplied with 3 x 400 V / 3 x 460 V can be parameterized to 400 V / 87 Hz in order to connect motors with 230 V / 50 Hz. This may create further losses in the motor and lead to its overheating if the motor is dimensioned with insufficient power reserves.

#### Frequency inverter parameters

- **Clock frequency:** A high clock frequency leads to a better utilization factor of the motor. Optimum frequencies are 8 or 16 kHz. Parameters such as smooth running test quality (motor is running smoothly) and noise development are also affected positively by high frequencies.
- **Voltage increase:** Interroll motor windings are dimensioned for a rated voltage increase rate of 1 kV/μs. If a frequency inverter generates a steeper voltage increase, motor chokes must be installed between frequency inverter and motor. But since all drum motors from Interroll run in an oil bath, the risk of overheating or damage of the motor due to large voltage increase rates is extremely low. Contact your local Interroll dealer about the need for motor chokes.

## Interroll Drum motor series i, S, S/A, D

---

### Options and accessories

- **Voltage:** If a frequency inverter with single-phase supply is installed at the drum motor, it must be ensured that the specified motor is dimensioned for the frequency inverter output voltage and is connected accordingly. Single-phase motors cannot be operated on the frequency inverter.
- **Output frequency:** Applications with output frequencies in the speed range under field control above 70 Hz should be avoided (for asynchronous motors only). High frequencies can cause noise, vibrations and resonances and reduce the rated output torque of the motor. With 87-HZ technology, asynchronous motors can be operated up to a maximum frequency of 87 Hz. However, at 87 Hz the motor may not take up more power than specified on the type plate of the motor. 87-Hz technology requires a motor that has at least 75 % power reserves in 50-Hz operation. Caution should be exercised when using V/f-regulated inverters with frequencies below 20 Hz since it could result in overheating or power loss of the motor. For information about required power reserves, see your local Interroll dealer. Synchronous motors can be operated with frequency inverters that are sold by Interroll between 7 Hz and 200 Hz.
- **Motor output:** Not all frequency inverters can operate motors with more than 6 poles and/or output powers below 0.2 KW / 0.27 PS. If in doubt, please contact your local Interroll dealer or the supplier of the frequency inverters.
- **Frequency inverter parameters:** Frequency inverters are usually delivered with factory settings. Given these settings, the inverter is generally not immediately ready for operation. The parameters have to be adjusted to the respective motor. For frequency inverters sold by Interroll, startup instructions specifically created for drum motors for the respective frequency inverters can be supplied upon request.

## Interroll Drum motor series i, S, S/A, D

### Options and accessories

#### Encoder type BMB-6202 & 6205 SKF for the i-series

##### Manufacturer: SKF

The encoder consists of two components: A standard bearing with built-in magnetic encoder and a corresponding load resistance whose size varies depending on the operating voltage. The load resistance is not part of the scope of supply.

The resolution INC is determined by the size of the bearing and, therefore, by the motor frame size.

The resolution INC in increments per drum revolution is calculated as follows:

$$\text{INC} = p \times \text{gear ratio (i)}$$

The gear ratio (i) is listed in the drum motors main catalog and can be requested from Interroll.

p = number of encoder pulses per rotor revolution selected based on the following table:

Encoder type	Bearing size	Drum motor size	Pulses per rotor revolution (p)
EB-6202-SKF- HTLOC-32-N-0,5	6202	80i ... 138i <sup>1)</sup>	32
EB-6205-SKF- HTLOC-48-N-0,5	6205	165i ... 217i	48

<sup>1)</sup> For 80i, only available with a special shaft diameter of 25 mm.

#### Technical data

Rated operating voltage	4.5 to 24 V DC
Max. rated output current	20 mA
Max. operating current	8 to 10 mA
Pulses per revolution (p)	32/48
High voltage	> 3.5 V
Low voltage	< 0.1 V

## Interroll Drum motor series i, S, S/A, D

### Options and accessories

#### Connections

### NOTICE

#### Damage of the encoder from excessive voltages/currents

- ▶ Ensure that the maximum switching current is always less than 20 mA.
- ▶ Do not operate the encoder with voltages above 24 V.

Abbreviations see "List of abbreviations", page 108

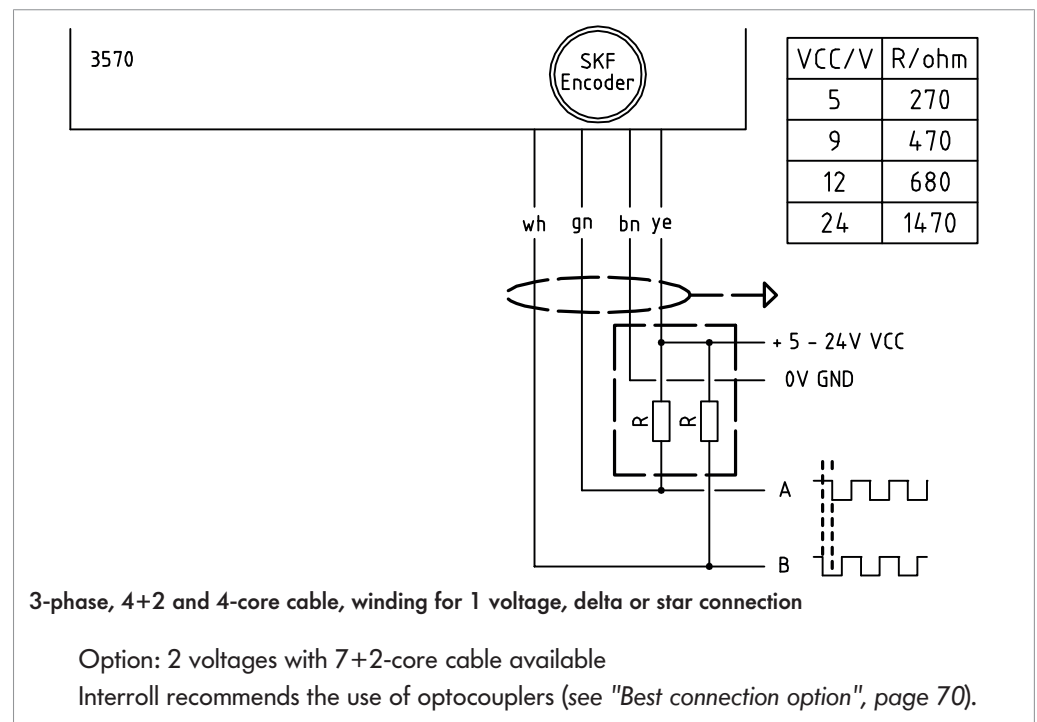

The signal sequence of A and B depends on the gear stages of the drum motor. For this reason, the rotational direction for drum motors with identical number of poles and output, but different gear stages. In this case, the signal cables A and B can be swapped with each other.

## Interroll Drum motor series i, S, S/A, D

### Options and accessories

#### Best connection option

#### Best connection option of an encoder with NPN open-collector output to an input device

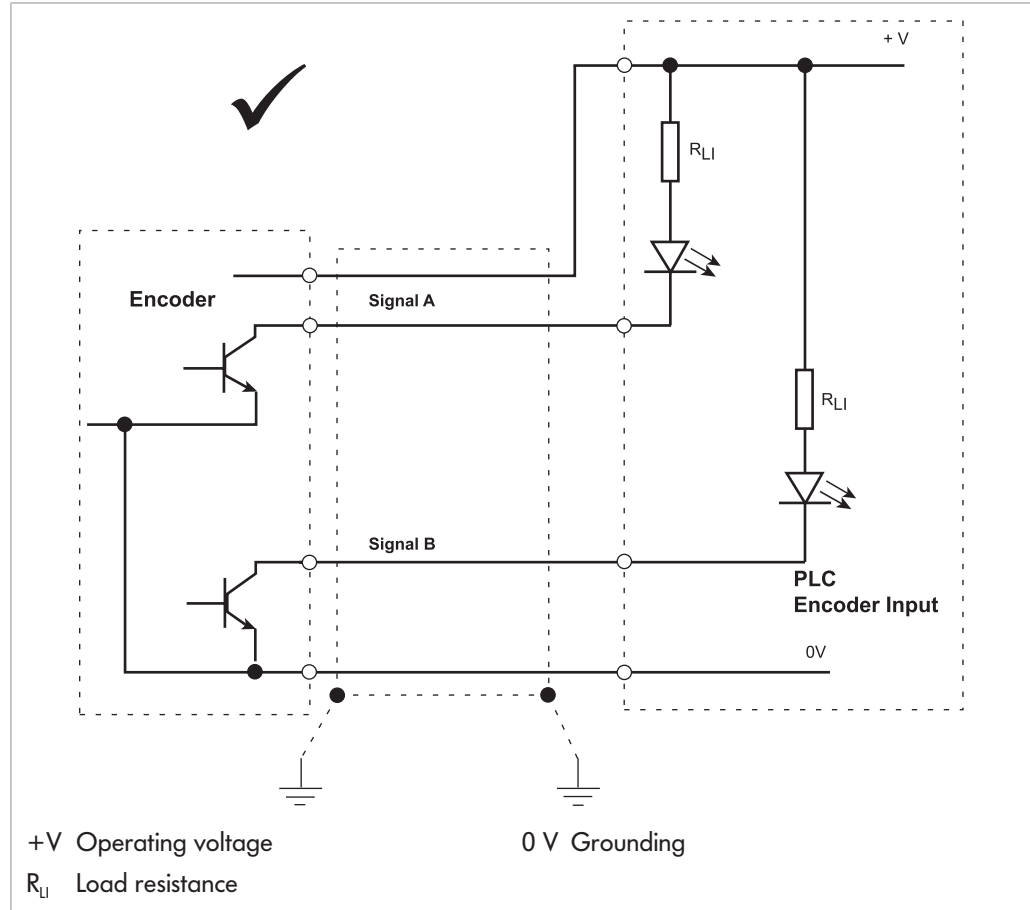

#### Requirement:

- ☑  $R_L$  must be dimensioned for the specified output current range of the encoder.
- ▶ Connect the encoder to an interface, following the illustration above as best as possible. The integrated load resistance  $R_L$  is generally dimensioned for a load current range of 15 mA so that no overload occurs at the encoder output. The signal level of some input devices can be set to NPN or PNP via the hardware or via the software. In this case, NPN is required.
- ▶ If this is not possible, use a signal coupler. The function of a signal coupler is shown in the illustration above. The following can be used:

WAGO	Electronics terminal with optocoupler	Reference no. 859-758
PHOENIX	Input optocoupler	Type: DEK-OE-24DC/24DC/100kHz
WEIDMUELLER	Optocoupler Waveseries	Type: MOS 12-28VDC 100kHz

## Interroll Drum motor series i, S, S/A, D

### Options and accessories

#### Encoder type RM44-RLS for the i and D-series

##### Output: Incremental, RS422A 5 V, push-pull, 24 V

The resolution INC in increments per drum revolution is calculated as follows:

$$\text{INC} = p \times i$$

p = number of encoder pulses per rotor revolution

i = gear ratio of drum motor

#### Technical data

	RS422A 5 V	Push-pull 24 V
Motor size	80i <sup>1)</sup> ... 217i D-series	80i <sup>1)</sup> ... 217i D-series
Supply voltage	5 V ± 5 %	8 - 26 V
Power supply	35 mA	50 mA at 24 V
Resolution p (pulses per revolution)	1024, 512 <sup>2)</sup>	1024, 512 <sup>2)</sup>
Output signal (RS422A)	A/ $\bar{A}$ , B/ $\bar{B}$ , Z/ $\bar{Z}$	A/ $\bar{A}$ , B/ $\bar{B}$ , Z/ $\bar{Z}$
Max. cable length	50 m	20 m
Accuracy <sup>3)</sup>	± 0.5°	± 0.5°
Hysteresis	0.18°	0.18°

<sup>1)</sup> For 80i, only available with a special shaft diameter of 25 mm.

<sup>2)</sup> Additional resolutions upon request. Please contact Interroll.

<sup>3)</sup> Worst-case scenario within the operating parameters, including magnet position and temperature.

## Interroll Drum motor series i, S, S/A, D

### Options and accessories

#### Connections

Abbreviations see "List of abbreviations", page 108

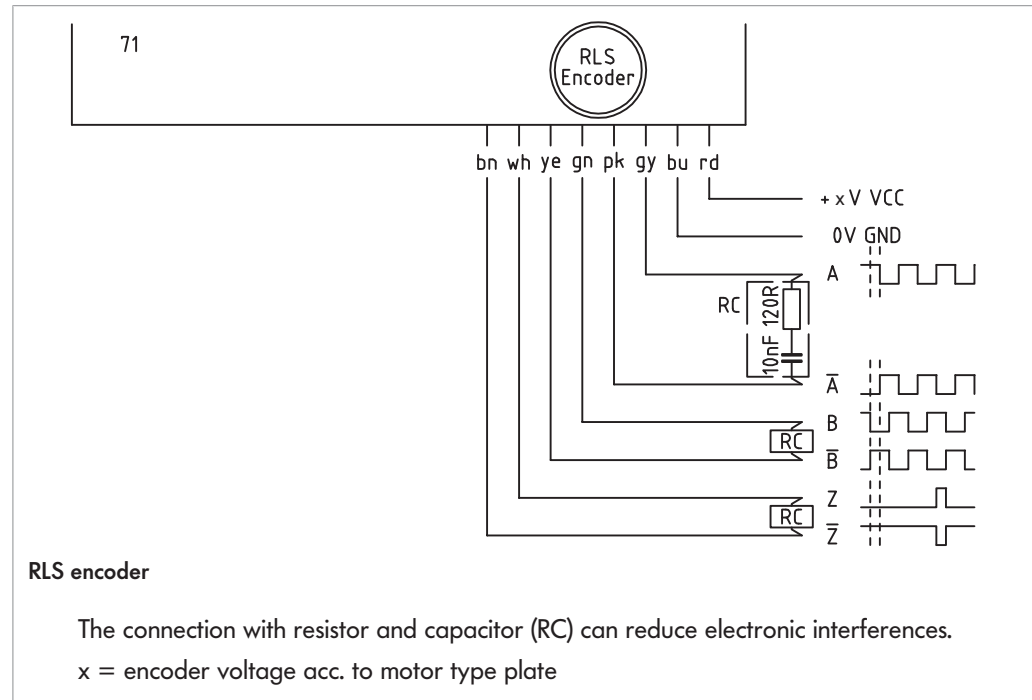

The signal sequence of A and  $\bar{A}$  and B and  $\bar{B}$  depends on the gear stages of the drum motor. For this reason, the rotational direction for drum motors with identical number of poles and output, but different gear stages. In this case, the signal cables A and  $\bar{A}$  and B and  $\bar{B}$  can be swapped with each other.

#### Signal connection

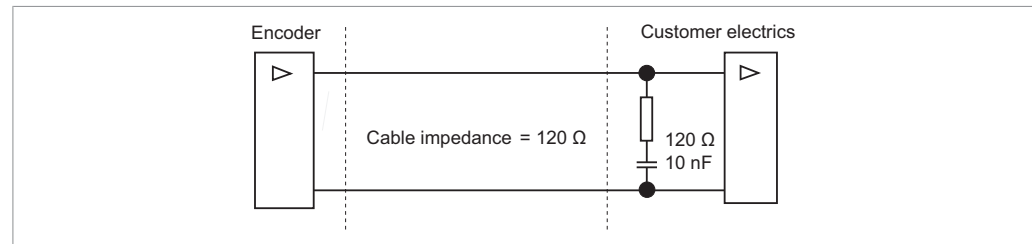



## Interroll Drum motor series i, S, S/A, D

### Options and accessories

#### Resolver type RE-15-1-LTN

A resolver is an inductive, robust feedback system. It is integrated in the drum motor and is used primarily in servo systems.

#### Connections

Abbreviations see "List of abbreviations", page 108

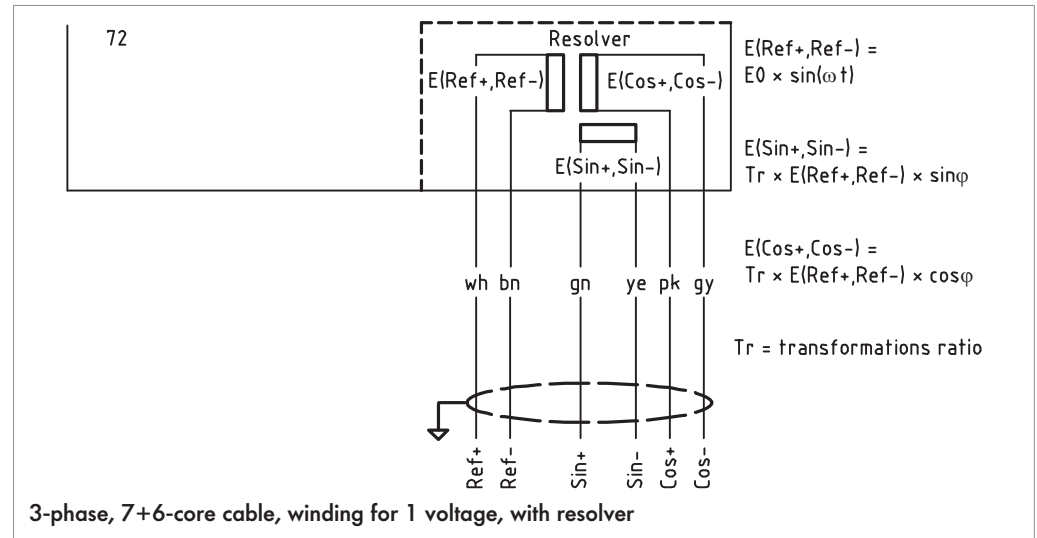

Connection	Ref+ to Ref-	Cos+ to Cos-	Sin+ to Sin-
Resistance	40 $\Omega$	102 $\Omega$	102 $\Omega$

#### Technical data

Input frequency	5 kHz	10 kHz
Input voltage	7 $V_{\text{rms}}$	
Input current	58 mA	36 mA
Phase shift ( $\pm 3^\circ$ )	$8^\circ$	$-6^\circ$
Zero voltage	max. 30 mV	
Accuracy	$\pm 10'$ , $\pm 6'$ upon request	
Harmonic	max. 1'	
Operating temperature	$-55^\circ\text{C}$ to $+155^\circ\text{C}$	
Max. permissible speed	20,000 1/min	
Rotor weight	25 g	
Stator weight	60 g	
Rotor moment of inertia	0.02 $\text{kgcm}^2$	
Hi-Pot housing/winding	min. 500 V	
Hi-Pot winding/winding	min. 250 V	
Stator length	16.1 mm	

## Interroll Drum motor series i, S, S/A, D

### Options and accessories

#### Impedance

Input frequency	5 kHz	10 kHz
$Z_{ro}$ in $\Omega$	75j 98	110j 159
$Z_{rs}$ in $\Omega$	70j 85	96j 150
$Z_{so}$ in $\Omega$	180j 230	245j 400
$Z_{ss}$ in $\Omega$	170j 200	216j 370

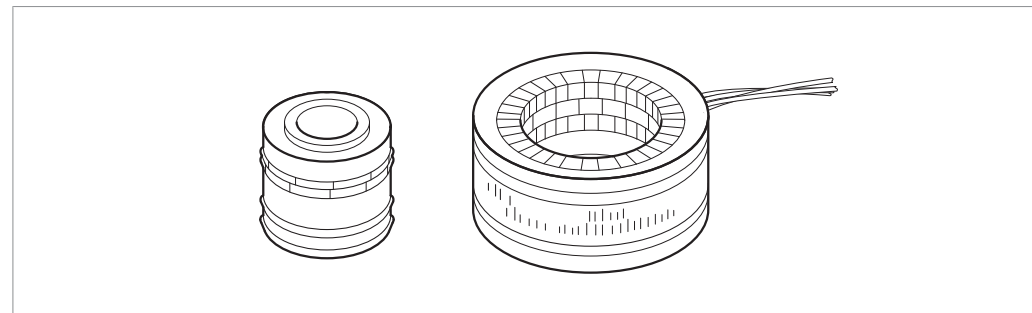
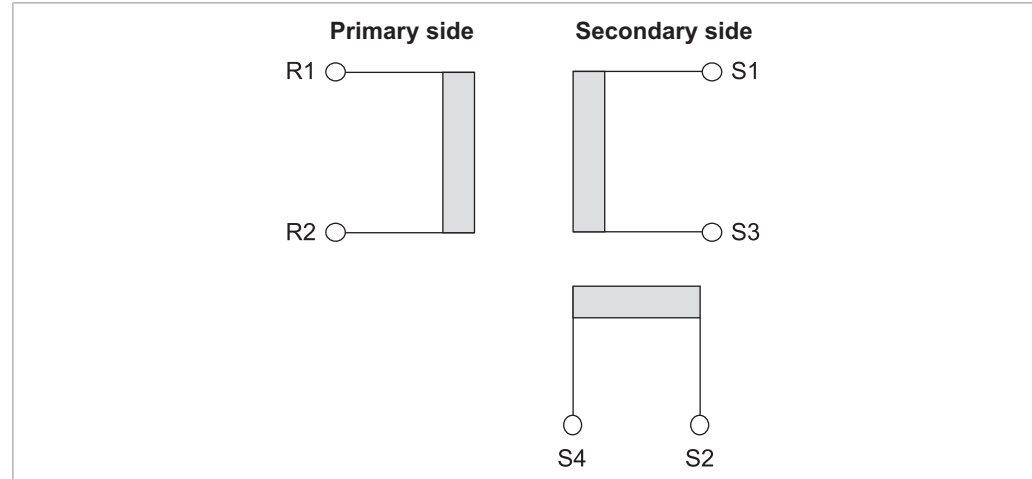

## Transport and storage

### Transport

---

#### **⚠ CAUTION**

##### **Improper transport poses a risk of injury.**

- ▶ Transport-related tasks should only be carried out by qualified and authorized persons.
  - ▶ For drum motors with a diameter of 136 mm or more, use a crane or hoisting equipment during the transport. The rated load of the crane or hoisting equipment must be greater than the weight of the drum motor. Crane rope/cable and hoisting equipment must be securely fastened to the shafts of the drum motor during lifting.
  - ▶ Do not stack pallets.
  - ▶ Before the transport, ensure that the drum motor is sufficiently secured.
- 

#### **NOTICE**

##### **Risk of damages to the drum motor due to improper transport**

- ▶ Avoid serious impacts during transport.
  - ▶ Do not lift the drum motor at the cable or terminal box.
  - ▶ Do not transfer the drum motors between warm and cold environments. This may lead to the formation of condensation.
  - ▶ For the transport in shipping containers, ensure that the temperature in the container is not permanently above 70 °C (158 °F).
  - ▶ Ensure that motors of the S-series that are intended for vertical mounting are transported in horizontal position.
- 

- ▶ Check each drum motor visually for damage after transport.
  - ▶ In the event of damage, take photos of the damaged parts.
  - ▶ In case of a transport damage, immediately notify the carrier and Interroll to avoid losing any claims for compensation.
- 

### Storage

---

#### **⚠ CAUTION**

##### **Risk of injury due to improper storage**

- ▶ Do not stack pallets.
  - ▶ Do not stack more than four cardboard boxes on top of each other.
  - ▶ Ensure that proper fastening is in place.
-



## Interroll Drum motor series i, S, S/A, D

---

### Transport and storage

- ▶ Store the drum motor horizontally in a clean, dry and enclosed location at +15 to +30 °C; protect it from moisture and humidity.
- ▶ For storage times exceeding three months, turn the shaft occasionally to prevent damage to the shaft seals.
- ▶ Inspect each drum motor for damage after storage.

# Assembly and installation

## Warning notices concerning the installation

---

### CAUTION

#### Rotating parts and inadvertent startup of the motor



Risk of crushing for fingers

- ▶ Do not reach into areas between drum motor and conveyor belts or roller chains.
  - ▶ Install a protection device (such as a guard plate) to prevent fingers from getting trapped in the chain belts or roller chains.
  - ▶ Install an appropriate warning on the conveyor.
- 

### NOTICE

#### Risk of damage leading to failure or shortened service life of the drum motor

- ▶ Observe the following safety information.
  - ▶ Do not drop or mishandle the drum motor to avoid internal damages.
  - ▶ Prior to the installation, inspect each drum motor for damage after storage.
  - ▶ Do not hold, carry, or support the drum motor by the wires or terminal boxes extending out of the mounting shaft to avoid damage to the internal parts and seals.
  - ▶ Do not twist the motor cable.
  - ▶ Do not overtension the belt.
- 

#### Positioning the drum motor

- ▶ Ensure that the data on the type plate are correct, and match the ordered and confirmed product.



A special design must be used for installing the drum motor in non-horizontal applications. The exact version must be specified at the time of ordering. In case of doubt, contact Interroll.



The drum motor must be mounted horizontally with a clearance of  $\pm 5^\circ$  (drum motor 113S:  $\pm 2^\circ$ ; 113S/A:  $-5^\circ/+15^\circ$ ), unless specified differently in the order confirmation.

## Interroll Drum motor series i, S, S/A, D

### Assembly and installation

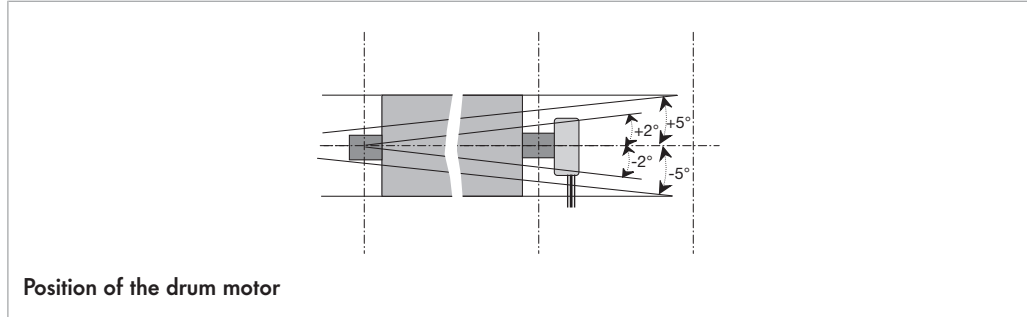

All drum motors are identified with the serial number on one end of the shaft and some with the letters UP.

### NOTICE

#### Property damages from incorrect mounting position

- ▶ Do not install motors of the i-series in the 180° mounting position (serial number must not be upside down).
- ▶ Ensure that the serial number and/or the UP indicator is located at one of the positions indicated in the following table.

The models 80S, 113S and the D-series can be installed in any orientation.

Motor type/mounting position	0°	-45°	-90°	45°	90°	180°
80i - 217i asynchronous motor	✓	✓	✓	✓	✓	⊘
80S / 113S / 113S/A	✓	✓	✓	✓	✓	✓
80D / 113D synchronous motor	✓	✓	✓	✓	✓	✓

#### Installing the motor with mounting brackets

The mounting brackets must be sufficiently robust to withstand the motor torque.

- ▶ Install the brackets at the conveyor or machine frame. Ensure that the drum motor is installed parallel to the idler pulley and at a right angle to the conveyor frame.
- ▶ Insert the shaft ends of the drum motor into the mounting brackets according to the "Mounting position" table (see above).
- ▶ If the shaft must be fastened to the mounting brackets (e.g. with a screw through a cross hole in the journal), it should be done only on one side so that the other side can move in axial direction in case of thermal expansion.
- ▶ Ensure that at least 80% of the drum motor flats are held by the mounting brackets.
- ▶ Ensure that the distance between the flats and the bracket is not more than 0.4 mm.
- ▶ If the drum motor is used for frequent reversing duty or for start/stop operation: Ensure that there is no gap between key surfaces and the mounting brackets.

## Interroll Drum motor series i, S, S/A, D

### Assembly and installation



The drum motor can also be installed without mounting brackets. In this case, the shaft ends must be installed into corresponding recesses in the conveyor frame; these recesses must be reinforced in such a way that they meet the aforementioned requirements.

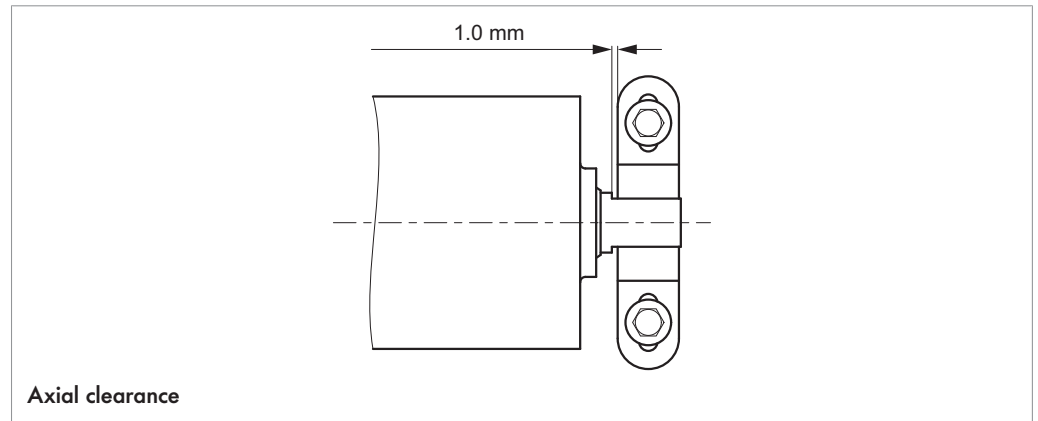

The entire axial clearance of the drum motor should be at least 1 mm (0.5 mm per side) and no more than 2 mm (1 mm per side).

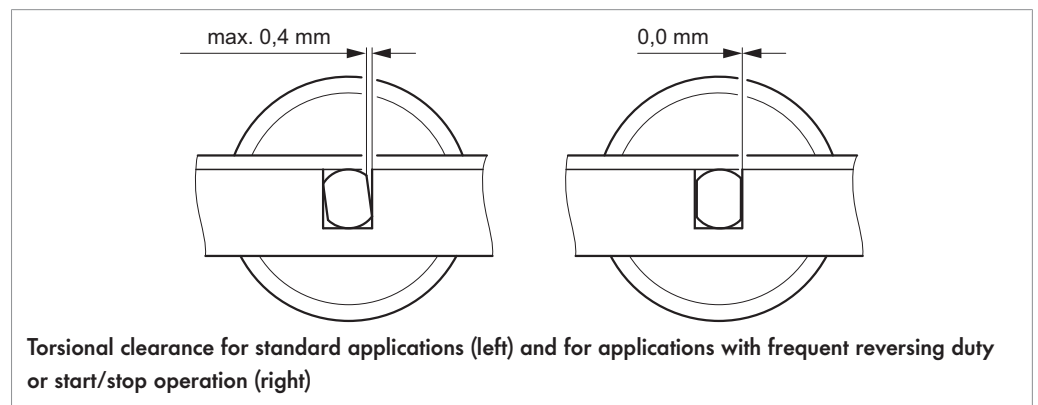

- ▶ If necessary, install a support plate above the mounting bracket to secure the drum motor shaft.

## Interroll Drum motor series i, S, S/A, D

### Assembly and installation

#### Installation considering hygienic aspects

- ▶ Ensure that the installation position is open and easily accessible to facilitate cleaning or testing.

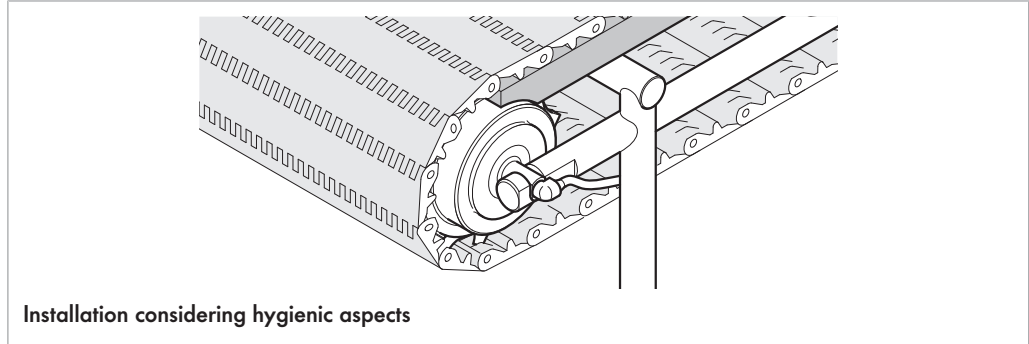

- ▶ To adhere to the recommendations of the EHEDG, it must be ensured that there is no metal-to-metal contact at the bearing surfaces between motor shaft and conveyor frame, e.g. by inserting a rubber seal between shaft and frame. The material of the seal must meet the specifications of the USDA/FDA and EG 1935/2004.

### Belt assembly

#### Belt width / tube length

#### **NOTICE**

##### **Risk of overheating if belt is too small**

- ▶ Ensure that the drum motor is operated with a conveyor belt that covers at least 70 % of the drum tube.

For drum motors with less than 70 % belt contact and drum motors with form-fit driven belts or without belt, a motor dimensioned for this purpose is required. This must be specified at the time of ordering. If in doubt, please contact Interroll.

#### Belt adjustment

Convex tubes center and guide the belt during regular operation. Nevertheless, the belt should be carefully aligned, frequently checked during startup and readjusted depending on the load.

#### **NOTICE**

##### **Adjustment errors can lead to a shortened service life as well as damages of the belt and the drum motor ball bearings.**

- ▶ Adjust the drum motor, belt and idler pulleys according to the instructions in this instruction manual.
- ▶ Adjust the belt with the synchronous returning rollers and support rollers and/or (if available) with the idler pulleys or snub pulleys.



## Interroll Drum motor series i, S, S/A, D

### Assembly and installation

- ▶ Check the diagonal dimensions (between the shafts of the drum motor and the shafts of the end/guide rollers or from belt edge to belt edge).  
The difference must not be greater than 0.5 %.



The idler pulley should be cylindrical since a camber in the idler pulley could work against the camber in the drum motor, thereby causing a belt migration.

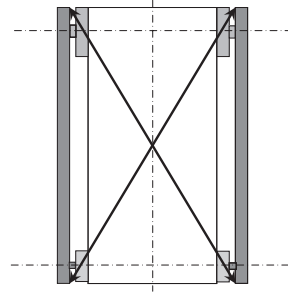

Diagonal check

The distance between the belt and the gliding plate must not exceed 3 mm.

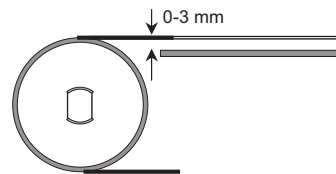

Belt position

### Tensioning the belt

The required belt tension depends on the respective application. The pertinent information is located in the catalog of the belt manufacturer, or contact Interroll.

## NOTICE

**Overtensioned belts can lead to a shortened service life, wear of bearings or oil leakage.**

- ▶ Do not tension the belt beyond the value recommended by the manufacturer or specified in the product tables of the catalog.
  - ▶ Link belts, steel belts, Teflon-coated fiberglass belts and hot-formed PU belts should not be tensioned (see the instructions from the belt manufacturer).
- 
- ▶ Adjust the belt tension by tightening or loosening the corresponding screws on both sides of the conveyor to ensure that the drum motor is positioned at a right angle to the conveyor frame and parallel to the end roller/idler pulley.
  - ▶ Tension the belt only so much that belt and load are being driven.

## Interroll Drum motor series i, S, S/A, D

### Assembly and installation

#### Belt tension

The following must be observed when calculating the belt tension:

- Length and width of conveyor belt
- Belt type
- The belt tension required for transporting the load
- The belt elongation required for the assembly (depending on the load, the belt elongation for the assembly should measure between 0.2 and 0.5 % of the belt length)
- The required belt tension must not exceed the maximum belt tension (TE) of the drum motor.

The values for the belt tension and elongation are available from the belt manufacturer.

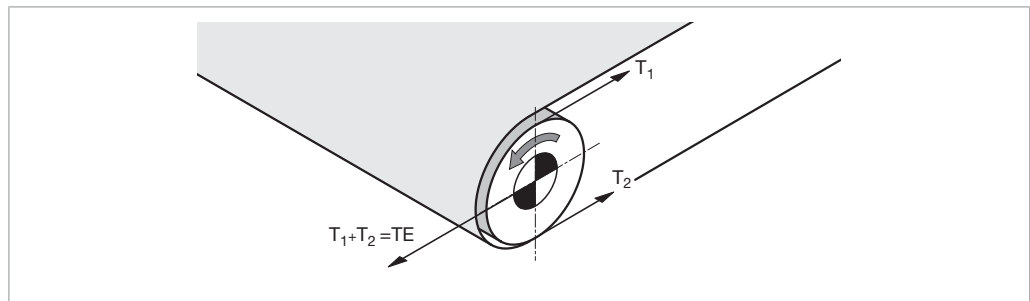

The required belt tension T1 (top) and T2 (bottom) can be calculated according to the specifications of DIN 22101 or CEMA. Based on the information from the belt manufacturer, the actual belt tension can be roughly determined by a measurement of the belt elongation during tensioning.

The maximum permissible belt tension (TE) of a drum motor is listed in the drum motor tables of the catalog. Belt type, belt thickness and drum motor diameter must match the information from the belt manufacturer. If the diameter of the drum motor is too small, it can lead to damages to the belt.

If the belt tension is too strong, it can damage the shaft bearings and/or other internal components of the drum motor and shorten the service life of the product.

#### Belt elongation

The belt tension is created by the force of the belt when it is stretched in longitudinal direction. To prevent damages to the drum motor, it is absolutely necessary to measure the belt elongation and to determine the static belt tensioning force. The calculated belt tension must be equal to or lower than the values specified in the drum motor tables of the catalog.

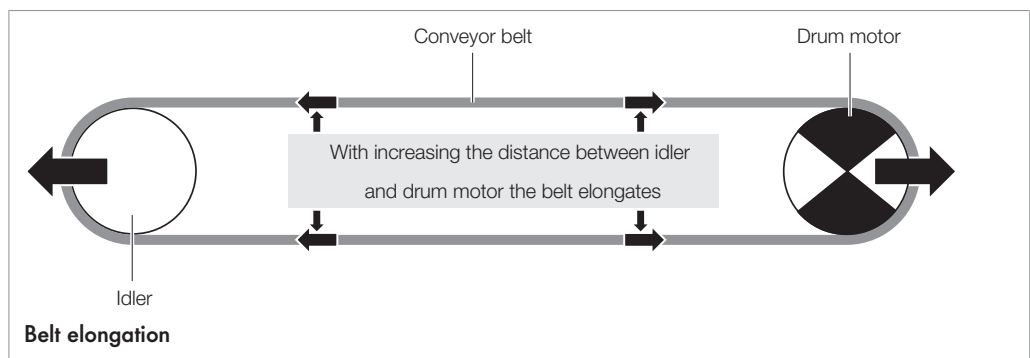

## Interroll Drum motor series i, S, S/A, D

### Assembly and installation

#### Measuring the belt elongation

The belt elongation can very easily be determined using a measuring tape.

- ▶ Mark the untensioned belt at two points in the center where the outer diameter of the drum motor and the idler pulley are the largest due to the camber.
- ▶ Measure the distance between the two markings parallel to the belt edge (Be0). The greater the distance between the two markings, the more precise the belt elongation can be measured.
- ▶ Tension and align the belt.
- ▶ Measure the distance between the markings (Be) again.

The belt elongation increases the distance.

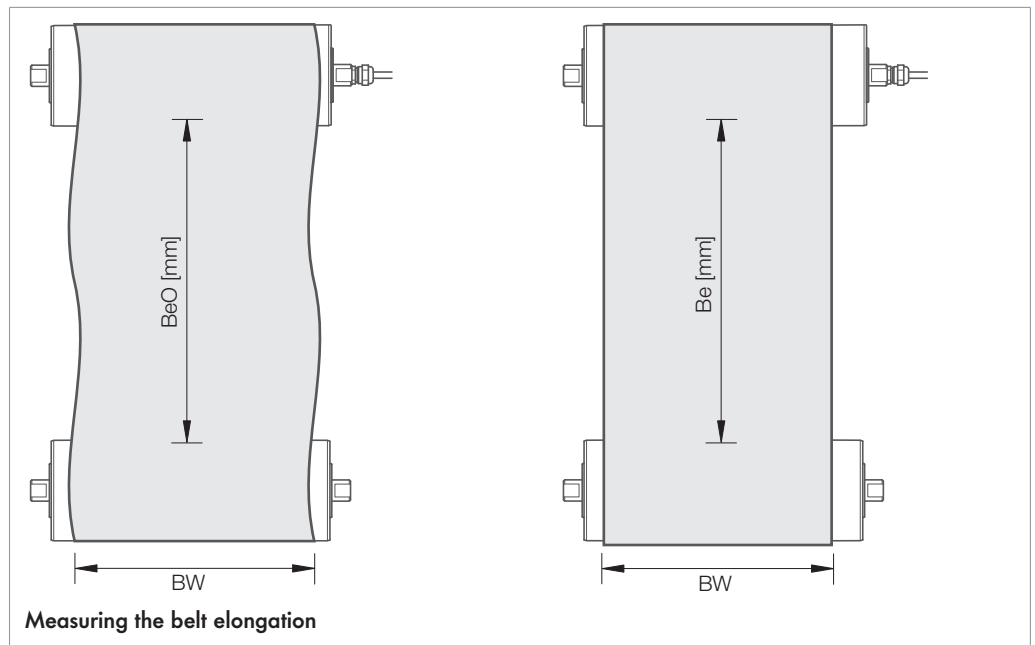

#### Calculating the belt elongation

The belt elongation can be calculated in % with the determined measure of the belt elongation.

$$B_{e\%} = \frac{B_e \cdot 100\%}{B_{e0}} - 100$$

Formula for calculating the belt elongation in %

Calculating the belt elongation requires the following values:

- Belt width in mm (BW)
- Static force per mm belt width with 1 % elongation in N/mm (k1 %). (The value is recorded on the data sheet for the belt or can be obtained from the belt supplier.)

$$TE_{[static]} = BW \cdot k1\% \cdot B_{e\%} \cdot 2$$

Formula for calculating the static belt tensioning force in N

## Interroll Drum motor series i, S, S/A, D

---

### Assembly and installation

#### Drum coating

A drum coating (e.g. rubber coating) that was applied retroactively can cause the drum motor to overheat. For some drum motors, there may be restrictions concerning the thickness of the drum coating.

To avoid a thermal overload, the required output should be multiplied with 1.2.



Please contact Interroll concerning the type and maximum thickness of a drum coating if you want to apply one.

#### Sprockets

To operate link belts with sprockets requires that a sufficient number of sprockets are attached to the drum shell in order to support the belt and to correctly transfer the force. Sprockets that engage with the belt must have a floating fit to prevent them from interfering with the thermal expansion of the belt. Only one sprocket may be affixed for belt guidance; as an alternative, the belt may also be guided at the sides.

For a belt guidance with fixed sprocket, the number of sprockets should be odd so that the fixed sprocket can be arranged in the center. At least one sprocket should be used for every 100 mm belt width. The minimum number of sprockets is 3.

The force is transferred using a key steel welded onto the drum tube. In general, this key steel is 50 mm shorter than the tube length (SL).

---

## **NOTICE**

### **Damage to the belt**

- ▶ Do not use a fixed sprocket together with side guides.
-

## Interroll Drum motor series i, S, S/A, D

---

### Assembly and installation

### Warning notices concerning the electrical installation

---

#### **⚠ WARNING**

##### **Electrocution due to improper installation**

- ▶ All electrical work should only be performed by qualified and authorized persons.
  - ▶ Disconnect the power supply before installing, removing or rewiring the drum motor.
  - ▶ Always observe the connection instructions and ensure that the power and control circuits of the motor are correctly connected.
  - ▶ Ensure that metal conveyor belt frames are sufficiently grounded.
- 

#### **NOTICE**

##### **Damage of the drum motor from incorrect power supply**

- ▶ Do not connect an AC drum motor to an excessively high DC voltage supply and a DC drum motor to an AC voltage supply – this will lead to irreparable damages.
  - ▶ Do not connect drum motors of the D-series directly to the supply system. D-drum motors must be operated via suitable frequency inverters or servo drive controllers.
- 

#### **Connecting the drum motor – with a cable**

##### **Electrical connection of the drum motor**

- ▶ Ensure that the motor is connected to the correct supply voltage according to the motor type plate.
  - ▶ Ensure that the drum motor is correctly grounded with the yellow-green cable.
  - ▶ Connect the drum motor according to the connection diagrams (see "Connection diagrams for the i-series", page 30 or see "Connection diagrams for the S-series", page 45 or see "Connection diagrams for the S/A-series", page 51 or see "Connection diagrams for the D-series", page 57).
- 

#### **Connecting the drum motor – with a terminal box**

#### **NOTICE**

##### **Damage to the internal wiring due to changes to the terminal box**

- ▶ Do not disassemble, reassemble or modify the terminal box.
  - ▶ Remove the cover of the terminal box.
  - ▶ Ensure that the motor is connected to the correct supply voltage according to the motor type plate.
  - ▶ Ensure that the terminal box of the drum motor is correctly grounded.
  - ▶ Connect the drum motor according to the connection diagrams (see the chapter "Connection diagrams" of the respective series).
  - ▶ Replace cover and seals. Tighten the screws of the cover with 1.5 N to ensure that the terminal box is sealed tight.
-

## Interroll Drum motor series i, S, S/A, D

---

### Assembly and installation

#### Single-phase motor

If a starting torque of 100% is required, single-phase drum motors, should be connected to a starting capacitor and a run capacitor. An operation without starting capacitor can reduce the starting torque to 70 % of the rated torque listed in the Interroll catalog.

Connect the starting capacitors according to the connection diagrams (see "Connection diagrams for the S-series", page 45).

#### External motor protection

The motor must always be installed together with a suitable motor protection, e.g. a motor circuit breaker or frequency inverter with overcurrent protective function. The protective device must be adjusted to the rated current of the respective motor (see type plate).

#### Integrated thermal protection

---

### CAUTION

#### Accidental motor start

Crushing hazard for fingers

- ▶ Connect the integrated thermal circuit breaker to an external control device that interrupts the current supply to the motor at all poles in case of overheating.
- ▶ After the thermal circuit breaker has tripped, examine and remove the cause for overheating before the current supply is reactivated.

---

The standard maximum switching current of the thermal circuit breaker is 2.5 A. For other options, please contact Interroll.

For operational safety, the motor must be safeguarded against overload with an external motor protection, as well as an integrated thermal protection; otherwise, there is no warranty if the motor fails.

#### Frequency inverter

Asynchronous drum motors can be operated with frequency inverters. Frequency inverters from Interroll are general adjusted to factory setting and have to be parameterized for the respective drum motor. For this purpose, Interroll can supply parameterization instructions. In this case, please contact your local Interroll partner.

- ▶ If no frequency inverter from Interroll is used, the frequency inverter must be correctly parameterized according to the specified motor data. Interroll can provide only very limited support for frequency inverters that are not being sold by Interroll.
- ▶ Resonance frequencies in the power supply line must be prevented since they create voltage spikes in the motor.  
If the cable is too long, frequency inverters generate resonance frequencies in the line between frequency inverter and motor.
- ▶ Use a completely shielded cable to connect the frequency inverter to the motor.
- ▶ Install a sine-wave filter or a motor choke if the cable is longer than 10 meter or if a frequency inverter controls several motors.
- ▶ Ensure that the cable shield is connected to a grounded part according to the electrotechnical guidelines and local EMC recommendations.
- ▶ Always observe the installation guidelines of the frequency inverter manufacturer.

## Interroll Drum motor series i, S, S/A, D

---

### Assembly and installation

---

#### Backstop

### NOTICE

#### Damage of the drum motor with backstop due an incorrect connection of the rotational direction

- ▶ Connect the drum motor according to the connection diagrams (see the chapter "Connection diagrams" of the respective series). An arrow on the housing end cover on the electrical connection side of the drum motor shows the correct rotational direction.
- 

#### Electromagnetic brake

The drum motor is delivered with an installed electromagnetic brake (if it does not feature a 24-V-DC brake). The rectifier is an accessory part and must be ordered separate from the motor.

- ▶ Connect the rectifier and the brake according to the connection diagrams (see "Connection diagrams for the i-series", page 30).



The rectifier has an AC input and a DC output to the brake winding.

---

### DANGER

#### Risk of injuries when used as safety brake

When large loads are being held, the motor can unexpectedly rotate in the opposite direction. As a result, loads may fall down and hit or fatally injure persons.

- ▶ Do not use the electromagnetic brake as safety brake.
  - ▶ If a safety brake is required, install a suitable additional safety brake system.
- 

### NOTICE

#### Damage of the drum motor and the brake if both are operated simultaneously

- ▶ Route the control circuits in such a way that motor and brake do not work against each other.
  - ▶ Consider the response time for applying and releasing the brake (depending on temperature and oil viscosity, it can amount to 0.4 to 0.6 seconds).
  - ▶ Apply the brake only after the current supply to the motor has been switched off.
  - ▶ Start the motor only after the brake has been released.
- 

### NOTICE

#### Damage of the drum motor due to insufficient holding torque of the brake

The holding torque of the brake can be too small for the rated torque of some motors.

- ▶ Ensure that the holding torque of the brake is sufficient. Contact Interroll for the required holding torque.
-

## Interroll Drum motor series i, S, S/A, D

---

### Assembly and installation

The cable should be as short as possible, and the cable cross section should correspond to the national/international regulations so that the voltage supply at the rectifier does not deviate from the rated voltage by more than  $\pm 2\%$ .



If the drum motor with electromagnetic brake is used at an ambient temperature below  $+5\text{ }^{\circ}\text{C}$ , a special oil must be used. In case of doubt, contact Interroll.

The electromagnetic brake is a pure holding brake and should not be used for positioning or braking the motor. Positioning applications should be implemented with a frequency inverter in conjunction with an encoder integrated in the motor. Braking applications should be implemented with a frequency inverter.



### Initial startup and operation

#### Initial startup

The drum motor may be put into operation only if it is correctly installed and connected to the power supply and all rotating parts have been fitted with the corresponding protective devices and guards.

#### Checks before the initial startup

The drum motor is filled with the correct oil quantity at the factory and ready for installation. Prior to the initial startup of the motor, the following steps have to be performed:

- ▶ Ensure that the motor type plate matches the version ordered.
- ▶ Ensure that no contact points exist between objects, conveyor belts and rotating or moving parts.
- ▶ Ensure that the drum motor and the conveyor belt can move freely.
- ▶ Ensure that the belt features the correct tension according to the recommendations from Interroll.
- ▶ Ensure that all bolts are tightened according to the specifications.
- ▶ Ensure that no additional dangerous areas arise due to interfaces to other components.
- ▶ Ensure that the drum motor is correctly wired and connected to the voltage supply with the correct voltage.
- ▶ Check all safety devices.
- ▶ Ensure that no bystanders are in dangerous areas around the conveyor.
- ▶ Ensure that the external motor protection is correctly adjusted to the rated motor current and a corresponding switching device can switch off the motor voltage at all poles if the integrated thermal circuit breaker trips.

## Interroll Drum motor series i, S, S/A, D

---

### Initial startup and operation

### Operation

---

#### CAUTION

##### Rotating parts and accidental starting



Risk of crushing for fingers

- ▶ Do not reach between drum motor and belt.
  - ▶ Do not remove the protection device.
  - ▶ Keep fingers, hair and loose clothing away from the drum motor and the belt.
  - ▶ Keep wristwatches, rings, necklaces, piercings and comparable jewelry away from the drum motor and the belt.
- 

#### NOTICE

##### Damage of drum motor in reversing operation

- ▶ Ensure that a time delay is in place between forward and reversing movement. Before reversing, the motor must come to a complete standstill.
- 



If exact speeds are required, a frequency inverter and/or encoder may have to be used. The specified rated speeds of the motor can deviate by  $\pm 10\%$ . The belt speed indicated on the type plate is the calculated speed at the drum diameter under full load, rated voltage and rated frequency.

##### Checks before every startup

- ▶ Check the drum motor for visible damage.
- ▶ Ensure that no contact points exist between objects, conveyor belts and rotating or moving parts.
- ▶ Ensure that the drum motor and the conveyor belt can move freely.
- ▶ Check all safety devices.
- ▶ Ensure that no bystanders are in dangerous areas around the conveyor.
- ▶ Clearly specify and monitor the way materials are placed on the conveyor.

##### Procedure in case of accident or fault

- ▶ Stop the drum motor at once and ensure that it cannot be started accidentally.
- ▶ In case of an accident: Provide first aid and make an emergency call.
- ▶ Inform the responsible person.
- ▶ Have the malfunction repaired by qualified persons.
- ▶ Start the drum motor only after this has been approved by qualified persons.

# Maintenance and cleaning

## Warning notices concerning maintenance and cleaning

---

### **⚠ CAUTION**

#### **Risk of injury due to improper handling or accidental motor starts**

- ▶ Maintenance work and cleaning must only be performed by qualified and authorized persons.
  - ▶ Perform maintenance work only after switching off the power. Ensure that the drum motor cannot be turned on accidentally.
  - ▶ Set up signs indicating that maintenance work is in progress.
- 

### **Preparation for maintenance and cleaning by hand**

- ▶ Switch off the power supply to the drum motor.
- ▶ Switch off the main power switch to switch off the drum motor.
- ▶ Open terminal box or distribution box and disconnect the cables.
- ▶ Attach a sign to the control station that maintenance work is in progress.

### **Maintenance**

Generally, Interroll drum motors do not have to be maintained and require no special care during their regular service life. Nevertheless, certain checks have to be performed at regular intervals:

#### **Checking the drum motor**

- ▶ Ensure daily that the drum motor can rotate freely.
- ▶ Check the drum motor for visible damage every day.
- ▶ Ensure daily that the belt is correctly aligned and centered on the drum motor as well as parallel to the frame of the conveyor. Correct the alignment as necessary.
- ▶ Ensure weekly that motor shaft and brackets are firmly fastened to the conveyor frame.
- ▶ Ensure weekly that cables, lines and connections are in good condition and securely fastened.

#### **Relubricating the drum motor**

Some drum motors are equipped with grease nipples.

- ▶ In this case, refill the Shell Cassida RLS 2 foodgrade grease after every high-pressure cleaning with hot water.
- ▶ If cleaning is performed using only flowing warm water, relubricate the drum motor once every week.

#### **Maintaining drum motors with optional, relubricating IP66 seals**

- ▶ Lubricate the relubricating IP66 seals regularly with lubricant and/or a foodgrade grease according to operating and ambient conditions.
- ▶ Lubricate the motor more often if it is used under aggressive ambient conditions and in constant contact with water, salt, dust, etc. or under full load.

## Interroll Drum motor series i, S, S/A, D

---

### Maintenance and cleaning

#### Oil change at drum motor

An oil change is not required, but it can be performed for special reasons (for i-series only).

---

#### **⚠ WARNING**

**The oil can ignite, create slippery surfaces and contain hazardous substances.**

Risk of damages to a person's health or the environment

- ▶ Do not ingest the oil. Ingestion can lead to nausea, vomiting and/or diarrhea. Generally, medical care is not required, unless large quantities have been ingested. Nevertheless, a physician should be consulted.
  - ▶ Avoid skin and eye contact. Prolonged or repeated skin contact without proper cleaning can clog the pores of the skin and lead to skin problems such as oil acne and folliculitis.
  - ▶ Wipe up spilled oil as quickly as possible to avoid slippery surfaces; ensure that the oil does not reach the environment. Properly dispose of dirty rags or cleaning materials to avoid self-ignition and fires.
  - ▶ Extinguish oil fires with foam, spraying water or water mist, dry chemical powder or carbon dioxide. Do not extinguish with water jet. Wear suitable protective clothing, incl. breathing mask.
- 

#### **NOTICE**

**Damage to the motor from incorrect oil**

- ▶ When changing the oil, observe the motor type plate or the list of oil types (see "Oil types", page 93).
  - ▶ Do not use oils with additives that could damage the motor insulation or seals.
  - ▶ Do not use any oil containing graphite or molybdenum disulfide as well as other oils based on electrically conducting substances.
- 
- ▶ Remove the oil drain plug and remove any metal particles on the magnetic oil drain plug (if installed).
  - ▶ Drain the oil from the drum motor and dispose of it according to the recommendations (see "Disposal", page 107).
  - ▶ Fill the drum motor with new oil (oil type and quantity according to the following tables).
  - ▶ Insert the oil drain plug into the drum motor and tighten it.

## Interroll Drum motor series i, S, S/A, D

### Maintenance and cleaning

Oil types	Drum motor	Oil type	Ambient temperature °C	Viscosity	Reference number
	80S	Mineral	+10 to +40	ISO VG 68	1001783
		Foodgrade, synthetic	+10 to +40	ISO VG 68	1001777
		For low temperatures, foodgrade, synthetic	-25 to +20	ISO VG 15	1001784
	113S	Mineral	0 to +40	ISO VG 32	1001782
		Foodgrade, synthetic	0 to +40	ISO VG 32	1001785
		For low temperatures, foodgrade, synthetic	-25 to +20	ISO VG 15	1001784
	80i	Mineral	+10 to +40	ISO VG 100	1001783
		For low temperatures, foodgrade, synthetic	-20 to +40	ISO VG 68	1001777
	80i with brake	For low temperatures, foodgrade, synthetic	-10 to +40	ISO VG 68	1001777
	113i to 217i	Mineral	+5 to +40	ISO VG 150	1101314
		For low temperatures, foodgrade, synthetic	-25 to +40	ISO VG 150	1001776
	113i to 217i with brake	Mineral	+10 to +40	ISO VG 150	1101314
		Foodgrade, synthetic	+10 to +40	ISO VG 150	1001776
		For low temperatures, foodgrade, synthetic	-10 to +15	ISO VG 68	1001777
	80D, 113D	Foodgrade, synthetic	-25 to +40	ISO VG 150	1001776

Foodgrade oils meet the following standards:

- FDA
- NSF International (categories H1, HT-1 and 3H)
- ISO 21469:2006
- EN 1672/2 (1997) and EC 389/89 (1989)
- Halal-Kosher

The ISO viscosity classes are based on ISO 3498-1979.



## Interroll Drum motor series i, S, S/A, D

### Maintenance and cleaning

Oil quantities for the  
i-series in liters  
(standard installation)

SL mm	80i	113i	138i	165i	217i*	217i			
	$SL_{min} =$ 250 mm	$SL_{min} =$ 300 mm	$SL_{min} =$ 300 mm	$SL_{min} =$ 350 mm	$SL_{min} =$ 400 mm	$SL_{min} =$ 450 mm	$SL_{min} =$ 400 mm	$SL_{min} =$ 500 mm	
200	0.12								
250	0.14	0.40							
300	0.17	0.50	0.40	0.70					
350	0.21	0.60	0.40	0.80	0.70				
400	0.25	0.60	0.50	1.00	0.80	1.20	3.10		
450	0.29	0.70	0.60	1.10	1.00	1.40	1.20	3.30	2.0
500	0.32	0.80	0.70	1.30	1.10	1.60	1.40	3.70	2.1
550	0.36	0.90	0.80	1.40	1.30	1.80	1.60	4.10	2.3
600	0.40	1.00	0.90	1.60	1.40	1.90	1.80	4.50	2.6
650	0.44	1.10	1.00	1.70	1.60	2.10	2.00	4.90	2.9
700	0.48	1.20	1.10	1.90	1.70	2.30	2.10	5.30	3.1
750	0.51	1.30	1.20	2.00	1.90	2.50	2.30	5.70	3.4
800	0.55	1.40	1.30	2.20	2.00	2.70	2.50	6.10	3.6
850	0.59	1.50	1.40	2.30	2.20	2.90	2.70	6.50	3.9
900	0.63	1.60	1.50	2.50	2.30	3.10	2.90	6.90	4.1
950	0.67	1.70	1.60	2.60	2.40	3.30	3.10	7.30	4.4
1000	0.70	1.80	1.70	2.70	2.60	3.50	3.30	7.70	4.7
1050		1.90	1.80	2.90	2.70	3.70	3.50	8.10	4.9
1100		2.00	1.90	3.00	2.90	3.80	3.70	8.50	5.2
1150		2.10	2.00	3.20	3.00	4.00	3.90	8.90	5.4
1200		2.20	2.10	3.30	3.20	4.20	4.00	9.30	5.7
1250		2.30	2.20	3.50	3.30	4.40	4.20	9.70	6.0
1300		2.40	2.30	3.60	3.50	4.60	4.40	10.10	6.2
1350		2.50	2.40	3.80	3.60	4.80	4.60	10.50	6.5
1400		2.60	2.50	3.90	3.80	5.00	4.80	10.90	6.7
1450		2.70	2.60	4.10	3.90	5.20	5.00	11.30	7.0
1500		2.80	2.70	4.20	4.10	5.40	5.20	11.70	7.2
1550		2.90	2.80	4.40	4.20	5.60	5.40	12.10	7.5
1600		3.00	2.90	4.50	4.40	5.70	5.60	12.50	7.8

## Interroll Drum motor series i, S, S/A, D

### Maintenance and cleaning

#### Oil quantities for the i-series (vertical installation)

Type	Liter	Electrical connection	Version
80i	0.20	Top	Special version
113i	0.60	Top	Special version
138i	2.00	Top	Special version
165i	3.00	Top	Special version
217i	5.00	Top	Special version

### Cleaning



Material deposited on the drum motor or the underside of the belt can lead to slippage of the belt and to damage to the belt. Material deposited between belt and gliding plate or rollers can also lead to a decrease of the belt speed and to increased current consumption. Regular cleaning guarantees a high effect on the drive and a correct alignment of the belt.

- ▶ Remove foreign material from the drum shell.
- ▶ Do not use sharp-edged tools to clean the drum shell.

#### Cleaning the drum motor with pressure washer

Only drum motors made of stainless steel with IP66 or IP69k seal are suitable for cleaning with a pressure washer.

## NOTICE

### Seal not tight due to excessive pressure

- ▶ Do not hold the nozzle in a position directed onto the shaft seal when cleaning the labyrinth or the seal.
- ▶ Move the nozzle continuously and evenly over the entire drum motor.

Observe the following when using a pressure washer:

- ▶ Ensure that the distance between the high-pressure nozzle and the drum motor is at least 30 cm.
- ▶ Observe the maximum pressure from the table below.
- ▶ Perform the pressure washing of the drum motor only during running operation; otherwise, water could enter or the seals could be damaged.

The maximum value for cleaning temperature and pressure depends on the seal type.

Seal type	Max. temperature	Max. water pressure	Comment
NBR IP66 seal	80 °C	50 bar	All series for general use
NBR or FPM IP66 seal	80 °C	50 bar	i-series for wet and foodgrade applications

## Interroll Drum motor series i, S, S/A, D

### Maintenance and cleaning

Seal type	Max. temperature	Max. water pressure	Comment
Relubricating NBR IP66 seal	60 °C	50 bar	S-series for wet and foodgrade applications <ul style="list-style-type: none"> <li>▶ Relubricate motors of the S-series after cleaning (see "Relubricating the drum motor", page 91).</li> </ul>
PTFE IP69K seal	80 °C	80 bar	D-series for wet and foodgrade applications

### Hygienic cleaning

## NOTICE

### Risk of damages to the drum motor due to improper cleaning

- ▶ Never use an acidic cleaner together with a chlorinated cleaner since the resulting dangerous chlorine gases can damage stainless steel and rubber components.
- ▶ Do not apply any acidic cleaners to aluminum or zinc-plated components.
- ▶ Avoid temperatures over 55 °C so that no proteins can be deposited on the surface. Remove greases at lower temperatures and with suitable cleaners.
- ▶ Avoid water pressures over 20 bar so that no aerosols are created.
- ▶ Maintain a distance of 30 cm between the nozzle and the surface to be cleaned.
- ▶ Do not direct the nozzle directly onto the labyrinth and the seals.

- ▶ Wipe off larger, loose contamination.
- ▶ Pre-clean with water (20 bar, 55 °C).
- ▶ Direct the nozzle down onto the surface at an angle of 45°.
- ▶ For a more thorough cleaning, clean seals, grooves and other recesses with a soft brush.
- ▶ In case of heavy contamination, use a soft brush and/or a plastic scraper together with spraying water.
- ▶ Clean for approx. 15 minutes using a cold alkaline or acidic agent.
- ▶ Spray off cleaner with water (20 bar, 55 °C).
- ▶ Disinfect with cold agents for approx. 10 min.
- ▶ Spray off with water (20 bar, 55 °C).
- ▶ After cleaning, check surfaces, grooves and recesses for residues.



For scale deposits, we recommend the use of an acidic cleaner 1 to 4 times per month. If a cleaning with chlorine is permissible, we recommend alkaline cleaners and disinfectants. In this case, the last disinfecting step can be omitted depending on the degree of contamination.

- ▶ Observe the corresponding certificates at [www.interroll.com](http://www.interroll.com).



## Troubleshooting

### Troubleshooting

Fault	Possible cause	Remedy
Motor does not start or stops during operation	No power supply	Check the voltage supply.
	Incorrect connection or loose/ defective cable connection	Check connection according to connection diagram. Check whether cables are defective or connections are loose.
	Motor overheating	See the fault "Motor heats up in regular operation".
	Motor overload	Disconnect main power supply, determine and remove cause of overload.
	Internal thermal circuit breaker tripped / failure	Check whether it is overload or overheating. After cooling off, check continuity of internal thermal protection. See the fault "Motor heats up in regular operation".
	External thermal circuit breaker tripped / failure	Check whether it is overload or overheating. Check continuity and function of external overload protection. Check whether the correct motor current is set in the external overload protection.
	Motor winding phase error	Replace drum motor or contact local Interroll dealer.
	Motor winding short circuit (insulation fault)	Replace drum motor or contact local Interroll dealer.
	Brake does not apply	Check whether the brake works during start-up. During the brake release, one can generally hear the clicking noise of the brake in the motor. The drum tube must then easily turn by hand. Depending on the gear ratio, the motors can be turned more easily or harder. Check connections and continuity of the brake winding. If connections and brake winding are OK, check the rectifiers.
	Wrong rotation of backstop	Immediately switch off the current supply and turn drum by hand to determine whether the backstop is already mechanically damaged. Check the correct rotational direction of the connection and change the phase connection if necessary so that the drum shell turns in the correct direction or, if possible, reinstall the drum motor so that it turns in the other direction.

## Interroll Drum motor series i, S, S/A, D

### Troubleshooting

Fault	Possible cause	Remedy
Motor does not start or stops during operation	Drum shell or conveyor belt blocked	Ensure that belt and drum motor are not being blocked and all rollers and drum shells can turn freely. If the drum motor cannot turn freely, the gear box or the bearing may be blocked. In this case, contact the local Interroll dealer.
	Low ambient temperature / high oil viscosity	Check whether the oil viscosity is suitable for the current ambient temperature. If not, fill in new oil with the correct viscosity (only possible for i-series). Install a heater or more powerful drum motor. In this case, contact the local Interroll dealer.
	Gear box or bearing blocked	Check by hand if the drum shell can be turned freely. If not, replace drum motor or contact local Interroll dealer.
	Incorrect assembly	Check whether a starting capacitor is required for a single-phase motor. Ensure that the motor is not rubbing against the conveyor belt frame.
Motor is running, drum shell does not turn	Transfer loss	Contact local Interroll dealer.

## Interroll Drum motor series i, S, S/A, D

### Troubleshooting

Fault	Possible cause	Remedy
Motor heats up in regular operation	Overload of the drum motor	Check rated current for overload. Ensure that the motor is not rubbing against the conveyor belt frame.
	Ambient temperature above 40 °C	Check ambient temperature. If the ambient temperature is too high, install a cooling unit. Contact local Interroll dealer.
	Excessive or frequent stops/starts	Check whether the number of stops/starts corresponds to the specifications of the drum motor and reduce this number if necessary. Install a frequency inverter to optimize the motor output. Do not use motors of the S-series for start-stop operation. For motors of the i-series, the start-and-stop ramps may not be less than 0.5 seconds. Ramps can be set with a frequency inverter. For shorter ramps, a motor of the D-series must be used. Contact local Interroll dealer.
	Belt tension too high	Check belt tension and reduce as necessary.
	Motor is not suitable for the application	Check whether the application meets the specifications of the drum motor. Use special reduced-power motors for the operation with link belts or without belts.
	Coating too thick	Replace coating or contact local Interroll dealer.
	Wrong voltage supply	Check the voltage supply. For single-phase motors, ensure that the correct starting or run capacitors are used. For 3-phase motors, ensure that no phase has failed.
Loud noise of drum motor in regular operation	Wrong settings at frequency inverter	Check whether the frequency inverter settings meet the specifications of the drum motor and change them if necessary.
	Loose motor mount	Check motor mount, shaft tolerances and fasteners.
	Belt tension too high	Check belt tension and reduce as necessary.
	Wrong/incorrect profile between drum shell and belt	Ensure that belt and drum profile match and are correctly connected. Replace as needed. Observe installation guidelines of the belt manufacturer.
	Drum motor incorrectly mounted	Check the mounting location of the serial number (see "Positioning the drum motor", page 77).
	An outer conductor failed	Check connection, check supply system.

## Interroll Drum motor series i, S, S/A, D

### Troubleshooting

Fault	Possible cause	Remedy
Drum motor vibrates heavily	Wrong settings at frequency inverter	Check whether the frequency inverter settings meet the specifications of the drum motor and change them if necessary.
	Loose motor mount	Check motor mount, shaft tolerances and fasteners.
	Drum motor runs unevenly	Check whether the specifications of the drum motor contain a static or dynamic balancing and adjust it. Single-phase motors naturally do not run completely even and, for this reason, are louder and vibrate more than three-phase motors.
Drum motor runs with interruptions	Drum motor/belt is occasionally or partially blocked	Ensure that belt and drum motor are not being blocked and all rollers and drum shells can turn freely.
	Wrong or loose power cable connection	Check connections.
	Gear box is damaged	Check by hand if the drum shell can be turned freely. If not, replace drum motor or contact local Interroll dealer.
	Wrong or faulty voltage supply	Check the voltage supply. For single-phase motors: Check capacitors.
Drum motor/belt runs more slowly than specified	Wrong motor speed ordered/delivered	Check drum motor specifications and tolerances. Replace drum motor or contact local Interroll dealer.
	Drum motor/belt is occasionally or partially blocked	Ensure that belt and drum motor are not being blocked and all rollers and drum shells can turn freely.
	Wrong settings at frequency inverter	Check whether the frequency inverter settings meet the specifications of the drum motor and change them if necessary.
	Belt slips	See the fault "Belt slips on drum motor".
Drum motor/belt runs more slowly than specified	Coating slips on the drum shell	Check condition of coating and fix coating on drum shell. Replace coating. Sandblast or abrade drum surface to guarantee a good adhesion of the coating.
	Use of a 60-Hz motor in a 50-Hz supply system	Check whether motor specifications and tolerances correspond to the supply voltage/frequency. Replace drum motor or contact local Interroll dealer.

## Interroll Drum motor series i, S, S/A, D

### Troubleshooting

<b>Fault</b>	<b>Possible cause</b>	<b>Remedy</b>
Drum motor runs faster than specified.	Wrong motor speed ordered/delivered	Check drum motor specifications and tolerances. Replace drum motor or contact local Interroll dealer.
	Wrong settings at frequency inverter	Check whether the frequency inverter settings meet the specifications of the drum motor and change them if necessary.
	Use of a 50-Hz motor in a 60-Hz supply system	Check whether motor specifications and tolerances correspond to the supply voltage/frequency. Replace drum motor or contact local Interroll dealer.
	Thickness of rubber coating increased the belt speed beyond the rated speed of the motor	Measure thickness of rubber coating and check whether this value was considered and calculated in the selection of the drum motor speed. Reduce thickness of rubber coating or install a frequency inverter or install new drum motor with lower speed.
Motor winding: one phase failed	Failure/overload of winding insulation	Check continuity, current and resistance of phase winding. Replace drum motor or contact local Interroll dealer.
Motor winding: two phases failed	Power failure at one phase which leads to overload at the other two phases / separating failure	Check power supply to all phases. Check continuity, current and resistance of phase winding. Replace drum motor or contact local Interroll dealer.
Motor winding: all three phases failed	Motor overload / wrong current connection	Check whether the correct supply voltage is present. Check continuity, current and resistance of phase winding. Replace drum motor or contact local Interroll dealer.

## Interroll Drum motor series i, S, S/A, D

### Troubleshooting

Fault	Possible cause	Remedy
Belt slips on drum motor	Belt blocked	Ensure that belt and drum motor are not being blocked and all rollers and drum shells can turn freely.
	Friction too low between drum motor and belt	Check condition and tension of the belt. Check condition of drum shell or coating. Check whether oil or grease is between belt and drum motor.
	Friction too high between belt and bracket/gliding plate	Check underside of belt and gliding plate for contamination / defective surface coating. Check whether water entered between belt and gliding plate and a suction/draft occurs.
	Belt tension too low	Check condition of belt and tension or shorten it.
	Drum profile too low for link belt or wrong	Ensure that belt and drum profile / teeth are correctly connected. Ensure that height and tension of belt meets the manufacturer data.
	Oil, lubricant or grease between belt and drum shell of drum motor	Remove excess oil, grease or lubricant. Ensure correct functioning of cleaning devices.
	Diameter of start roller/end roller/transfer roller too low for the belt	Check minimum drum diameter for belt. Knife edges/roller with small diameter can cause an excessive friction and, therefore, a higher current demand.
	Coating slips on the drum shell	Check condition of coating and fix coating on drum shell. Replace coating. Sandblast or abrade drum surface to guarantee a good adhesion of the coating.
Belt skips on drum motor	Belt blocked or material deposits on the drum shells	Ensure that belt and drum shell are not being blocked and all rollers and drum shells can turn freely.
	Poor or damaged belt connection	Check belt connection. Ensure that the motor pulls the belt and does not push it.
	Friction too high between belt and gliding plate	
Conveyor belt loose or damaged	Conveyor belt loose or damaged	Check tension and condition of belt and condition of coating. Check belt tracking and belt adjustment.
	Wrong coating/sprocket profile for link belt	See the fault "Belt slips on drum motor".

## Interroll Drum motor series i, S, S/A, D

### Troubleshooting

Fault	Possible cause	Remedy
Belt not correctly adjusted / belt does not run centered	Material deposits on drum motor/rollers/belt	Ensure that belt and drum shell are not being blocked and all rollers and drum shells can turn freely. Check belt connection.
	Material deposits on rollers	Check whether material detaches itself and ensure that the cleaning devices function correctly.
	Defective or poorly fixed belt	Check belt condition and belt connections.
	Belt tension higher on one side	Ensure that the belt tension is equal on both sides. Check whether continuous connection of belt was done in parallel.
	Top/bottom rollers not correctly adjusted	Check adjustment of support and returning rollers.
	Start roller/end roller/interim roller not correctly adjusted	Check adjustment of drum motor and roller.
	Conveyor frame not correctly adjusted	Ensure that the conveyor frame is rectangular, parallel and straight over the entire length.
	Feeding materials from one side	Check force or friction at transfer point.
	Belt profile not connected with drum profile	Ensure that belt and drum profile match and are correctly connected and adjusted.
	Drum camber too low for belt	Check belt / drum motor specifications.
Oil exiting at shaft seal	Shaft seal worn	Check whether negative chemical or aggressive materials/ conditions are present. Check operating service life of seals.
	Shaft seal damaged	Ensure that there are no steel residues, material deposits or other particles at the seals.
	Cap bearing damaged / worn	Check whether the belt is tensioned or loaded too much. Check whether water or chemicals have entered.
	Excess grease in labyrinth seal	Check whether oil or grease is exiting. Oil remains fluid and grease hardens when it cools down. Remove excess grease. If the problem persists, contact local Interroll dealer. Small amount of grease exiting in the S-series is normal and not a problem.
Oil exiting at the cable/ terminal box	Loose cable connection socket Defect at internal cable seal	Ensure that cable connection socket and seals are tight and not stressed by overheating or chemicals.
	Loose cable connection socket Seal at terminal box defective	Ensure that cable connection socket and seals at terminal box are tight and not stressed by overheating or chemicals.

## Interroll Drum motor series i, S, S/A, D

### Troubleshooting

Fault	Possible cause	Remedy
Oil exiting at drum shell/end cap	End cap in drum shell is loose	Check whether there are gaps between drum shell and end housing. Check whether the belt is tensioned too much or impact-loaded.
	End cap/drum seal defective	Check whether the belt is overheated, tensioned too much or impact-loaded.
Oil discolorization - silver-metallic particles	Wear of gear teeth or bearings	Check condition of bearings and seals. Check whether an overload is present.
Oil discolorization - white colorization	Contamination through water or other liquid	Check condition and contamination through water/liquid. Change oil (see "Oil change at drum motor", page 92).
Oil discolorization - black colorization	Extremely high operating temperature Overload No belt installed	Check whether the application / operating conditions meet/meets the specifications of the drum motor. Check whether an overload current or high ambient temperature is present.
Cable/terminal box defective or damaged	Wrong operation by the customer or damage during installation	Check type of damage and possible cause. Replace terminal box.
	Damage during transport	Check type of damage and possible cause. Replace terminal box.
Cap bearing failed	Overload	Check whether the load of the application meets the specifications of the drum motor.
	Impact load	Check whether the load of the application meets the specifications of the drum motor.
	Belt tension too high	Check whether the belt is tensioned too much. Reduce belt tension as necessary.
	Poor lubrication	Check oil level and installation of drum motor. With vertical mounting or if the motor is tilted by more than 5° (2° for 113S), check motor specifications of drum motor.
	Loading or wrong adjustment of shaft	Check whether screws have been overtightened and whether frame or motor mount are incorrectly adjusted.
	Shaft seal damaged/worn	Check for external contamination. Contact local Interroll dealer.
	Loose or fixed seating of bearing on the shaft	Contact local Interroll dealer.
Gear box failure	Overload/impact load or regular wear	Check whether the load of the application meets the specifications of the drum motor. Check service life.
Rotor bearing worn/failed	Poor lubrication	Check correct oil type and oil level.



## Interroll Drum motor series i, S, S/A, D

### Troubleshooting

Fault	Possible cause	Remedy
Rotor drive worn or teeth broken off	Excessive or frequent stops/starts, very high starting torque	Check whether the load of the application meets the specifications of the drum motor. Check oil, maximum number of stops/starts and permissible starting torque. Use frequency inverter with start-and-stop ramps (0.5 s or more).
Toothed sprocket worn or teeth/bolts broken off	Start-up under overload and/or impact load or blocking	Check whether the application and load meet the specifications of the drum motor. Check whether a blockage is present. Use frequency inverter with start-and-stop ramps (0.5 s or more).
Interim gear box and bearing worn/failed	Poor lubrication or worn gear box or bearing	Check oil level. Check service life and tolerances of journals and drives/shafts. Use frequency inverter with start-and-stop ramps (0.5 s or more).
Complete or temporary failure of brake and rectifier	Wrong operating voltage applied	Ensure that the correct rectifier was installed and that the correct input voltage (V/ph/Hz) is present.
	Wrong connection	Never connect the rectifier to the frequency inverter. Ensure that the brake was connected according to connection diagram.
	Insufficient shielding against external voltage spikes from cables and external devices	Ensure that all cables between brake, rectifier and voltage supply are shielded and grounded according to IEC recommendations.
Complete or temporary failure of brake and rectifier	Voltage drop due to cable with excessive length	Check whether a voltage drop occurs in long cables and ensure that the cable cross section meets the IEC specifications.
	Excessive stops/starts	Ensure that the specifications for brake and rectifier meet the requirements of the application.
	Wrong rectifier connected	Contact Interroll. We will give you the name of the correct rectifier for the corresponding brake and application.
	Voltage overshoot / regeneration with connection of motor star point rectifier	Conveyor belts with incline can lead to an overload of the motor and cause a regeneration if motor star point voltage is applied.
	Short circuit of brake winding	Check continuity of winding and rectifier.
Slow switching of brake and rectifier	Wrong brake / wrong rectifier selected or specified	Ensure that the specifications for brake and rectifier meet the requirements of the application.
	Low ambient temperature or excessive oil viscosity	Ensure that the oil viscosity is suitable for the ambient temperature. If not, fill in new oil with the correct viscosity. Install a heater or more powerful motor. In this case, contact the local Interroll dealer.



## Interroll Drum motor series i, S, S/A, D

---

### Troubleshooting

<b>Fault</b>	<b>Possible cause</b>	<b>Remedy</b>
Encoder (temporarily) not working	Incorrect connection or loose/ defective cable connection	Check connection diagrams and determine whether cables are defective or connections are loose.
	Failure of electronic backfeed system	The troubleshooting should be performed only by an electrician.
	Error or failure of encoder	The troubleshooting should be performed only by an electrician.
	Error at PC or drive	The troubleshooting should be performed only by an electrician.

### Decommissioning and disposal

- ▶ When disposing the motor oil, observe the disposal documents of the motor manufacturer.
- ▶ The packaging must be recycled to provide environmental relief.

### Shutdown

---

#### CAUTION

##### **Risk of injury due to incorrect handling**

- ▶ Shut-down may only be executed by qualified and authorized persons.
  - ▶ Only shut down the drum motor after switching off the power. Ensure that the drum motor cannot be turned on accidentally.
- 
- ▶ Disconnect the motor cable from the power supply and motor control.
  - ▶ Relax the belt.
  - ▶ Remove holding plate from the motor mount.
  - ▶ Remove the drum motor out of the conveyor frame.

### Disposal

The operator is responsible for the proper disposal of the drum motor.

- ▶ In doing so, industry-specific and local provisions must be observed for the disposal of the drum motor and its packaging.

### Appendix

#### List of abbreviations

##### Electrical data

$P_N$ in kW	Rated output in kilowatt
np	Number of poles
$n_N$ in 1/min.	Rated speed of rotor in revolutions per minute
$f_N$ in Hz	Rated frequency in Hz
$U_N$ in V	Rated voltage in volt
$I_N$ in A	Rated current in ampere
$I_0$ in A	Rated open-circuit current in ampere
$I_{max}$ in A	Maximum current in ampere
cos $\varphi$	Power factor
$\eta$	Efficiency
$J_R$ in kgcm <sup>2</sup>	Rotor moment of inertia
$I_S/I_N$	Ratio of startup current to rated current
$M_S/M_N$	Ratio of starting torque to rated torque
$M_p/M_N$	Ratio of pull-up torque to rated torque
$M_B/M_N$	Ratio of pull-out torque to rated torque
$M_N$ in Nm	Rated torque of rotor in Newton meter
$M_0$ in Nm	Stalled torque in Newton meter
$M_{max}$ in Nm	Maximum torque in Newton meter
$R_M$ in $\Omega$	Phase resistance in ohm
$R_A$ in $\Omega$	Phase resistance of auxiliary winding in ohm
$L_{sd}$ in mH	Inductance of d-axes in millihenry
$L_{sq}$ in mH	Inductance of q-axes in millihenry
$L_{sm}$ in mH	Averaged inductance in millihenry
$k_e$ in V/krpm	Induced motor voltage
$T_e$ in ms	Electrical time constant in milliseconds
$k_{TN}$ in Nm/A	Torque constant in Newton meter per ampere
$U_{SH}$ in V	Heating voltage in volt
$U_{SH \text{ delta}}$ in V	Standstill heating voltage in delta connection in volt
$U_{SH \text{ star}}$ in V	Standstill heating voltage in star connection in volt
$U_{SH \sim}$ in V	Heating voltage for single-phase units in volt
$C_r$ in $\mu$ F	Run capacitor (1~) / Steinmetz capacitor (3~) in microfarad

## Interroll Drum motor series i, S, S/A, D

### Appendix

#### Connection diagrams

1~	Single-phase motor
3~	Three-phase motor
B1	Input of electromagnetic brake
B2	Output of electromagnetic brake
BR	Brake (optional)
Cos -	Cosine signal 0
Cos +	Cosine signal +
Cr	Run capacitor
Cs	Starting capacitor
FI	Frequency inverter
L1	Phase 1
L2	Phase 2
L3	Phase 3
N	Neutral conductor
NC	Not connected
RC	Series circuit of resistor and capacitor
Ref -	Reference signal 0
Ref +	Reference signal +
Sin -	Sine signal 0
Sin +	Sine signal +
T1	Input thermistor
T2	Output thermistor
TC	Thermal protection
U1	Input winding phase 1
U2	Output winding phase 1
V1	Input winding phase 2
V2	Output winding phase 2
W1	Input winding phase 3
W2	Output winding phase 3
Z1	Input auxiliary winding single-phase motor
Z2	Output auxiliary winding single-phase motor



## Interroll Drum motor series i, S, S/A, D

---

### Appendix

#### Color coding

Color coding of cables in the connection diagrams:

---

bk: black	gn: green	pk: pink	wh: white
bn: brown	gy: gray	rd: red	ye: yellow
bu: blue	or: orange	vi/vt: violet	ye/gn: yellow/green
(): alternate color			

---

## Interroll Drum motor series i, S, S/A, D

---

### Appendix

#### Installation declaration

In accordance with EC Machinery Directive 2006/42/EC, Appendix II 1 B.

The manufacturer:

Interroll Trommelmotoren GmbH  
Opelstr. 3  
D - 41836 Hueckelhoven/Baal  
Germany

hereby declares with sole responsibility that the product range

- Drum motor i-series
- Drum motor S-series
- Drum motor S/A-series
- Drum motor D-series

meets the following requirements in accordance with Appendix I of the above-referenced directive:

1.1.2, 1.1.3, 1.1.5, 1.5.8, 1.5.9, 1.6.4, 1.7.2.

The special technical documents according to Appendix VII Part B were created for the product. Upon justified request, these documents can be transmitted to a sovereign authority via e-mail.

#### Applied EU Directives:

- EMC Directive 2014/30/EU
- RoHS Directive 2011/65/EU
- Low Voltage Directive 2014/35/EU

#### Applicable harmonized standards:

- EN ISO 12100:2010-03
- EN 60034-1:2010/AC: 2010
- EN 60034-5:2001/A1:2007
- EN 60034-6:1993
- EN 60034-11:2004
- EN 60034-14:2004
- EN 60204-1:2006/AC: 2010

Person authorized to prepare the technical documents:

Holger Hoefler, Interroll Trommelmotoren GmbH, Opelstr. 3, D - 41836 Hueckelhoven, Germany

Initial startup of this product is not permitted until the machine or system in which this product is to be installed or of which it is a component complies with the requirements of all relevant directives.

Hueckelhoven - May 30, 2016

Dr. Hauke Tiedemann  
(Managing Director)

(This installation declaration can be obtained at [www.interroll.com](http://www.interroll.com), if needed.)

