

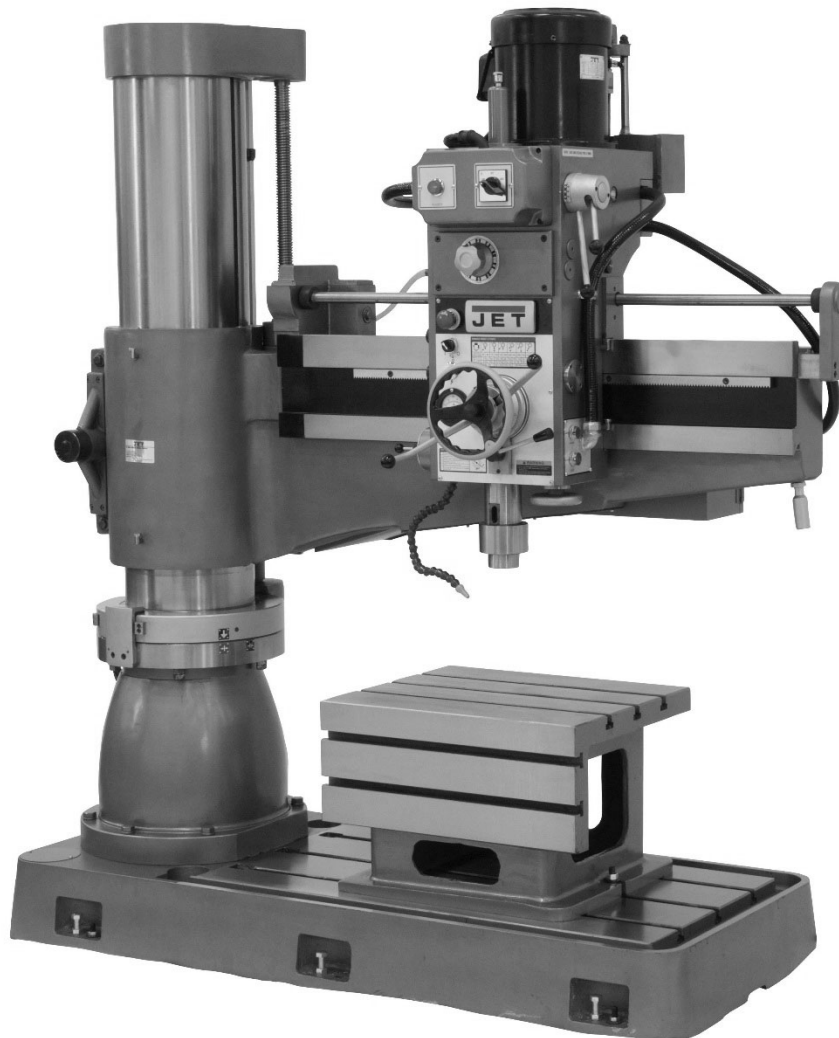

Operating Instructions and Parts Manual 4-ft. Radial Arm Drill Press

Models J-1230R, J-1230R-4



JET
427 New Sanford Road
LaVergne, Tennessee 37086
Ph.: 800-274-6848
www.jettools.com

Part No. M-320036
Revision F1 11/2020
Copyright © 2015 JET

1.0 Warranty and Service

JET warrants every product it sells against manufacturers' defects. If one of our tools needs service or repair, please contact Technical Service by calling 1-800-274-6846, 8AM to 5PM CST, Monday through Friday.

Warranty Period

The general warranty lasts for the time period specified in the literature included with your product or on the official JET branded website.

- JET products carry a limited warranty which varies in duration based upon the product. (See chart below)
- Accessories carry a limited warranty of one year from the date of receipt.
- Consumable items are defined as expendable parts or accessories expected to become inoperable within a reasonable amount of use and are covered by a 90 day limited warranty against manufacturer's defects.

Who is Covered

This warranty covers only the initial purchaser of the product from the date of delivery.

What is Covered

This warranty covers any defects in workmanship or materials subject to the limitations stated below. This warranty does not cover failures due directly or indirectly to misuse, abuse, negligence or accidents, normal wear-and-tear, improper repair, alterations or lack of maintenance. JET woodworking machinery is designed to be used with Wood. Use of these machines in the processing of metal, plastics, or other materials outside recommended guidelines may void the warranty. The exceptions are acrylics and other natural items that are made specifically for wood turning.

Warranty Limitations

Woodworking products with a Five Year Warranty that are used for commercial or industrial purposes default to a Two Year Warranty. Please contact Technical Service at 1-800-274-6846 for further clarification.

How to Get Technical Support

Please contact Technical Service by calling 1-800-274-6846. **Please note that you will be asked to provide proof of initial purchase when calling.** If a product requires further inspection, the Technical Service representative will explain and assist with any additional action needed. JET has Authorized Service Centers located throughout the United States. For the name of an Authorized Service Center in your area call 1-800-274-6846 or use the Service Center Locator on the JET website.

More Information

JET is constantly adding new products. For complete, up-to-date product information, check with your local distributor or visit the JET website.

How State Law Applies

This warranty gives you specific legal rights, subject to applicable state law.

Limitations on This Warranty

JET LIMITS ALL IMPLIED WARRANTIES TO THE PERIOD OF THE LIMITED WARRANTY FOR EACH PRODUCT. EXCEPT AS STATED HEREIN, ANY IMPLIED WARRANTIES OF MERCHANTABILITY AND FITNESS FOR A PARTICULAR PURPOSE ARE EXCLUDED. SOME STATES DO NOT ALLOW LIMITATIONS ON HOW LONG AN IMPLIED WARRANTY LASTS, SO THE ABOVE LIMITATION MAY NOT APPLY TO YOU. JET SHALL IN NO EVENT BE LIABLE FOR DEATH, INJURIES TO PERSONS OR PROPERTY, OR FOR INCIDENTAL, CONTINGENT, SPECIAL, OR CONSEQUENTIAL DAMAGES ARISING FROM THE USE OF OUR PRODUCTS. SOME STATES DO NOT ALLOW THE EXCLUSION OR LIMITATION OF INCIDENTAL OR CONSEQUENTIAL DAMAGES, SO THE ABOVE LIMITATION OR EXCLUSION MAY NOT APPLY TO YOU.

JET sells through distributors only. The specifications listed in JET printed materials and on official JET website are given as general information and are not binding. JET reserves the right to effect at any time, without prior notice, those alterations to parts, fittings, and accessory equipment which they may deem necessary for any reason whatsoever. JET® branded products are not sold in Canada by JPW Industries, Inc.

Product Listing with Warranty Period

90 Days – Parts; Consumable items
1 Year – Motors; Machine Accessories
2 Year – Metalworking Machinery; Electric Hoists, Electric Hoist Accessories; Woodworking Machinery used for industrial or commercial purposes
5 Year – Woodworking Machinery
Limited Lifetime – JET Parallel clamps; VOLT Series Electric Hoists; Manual Hoists; Manual Hoist Accessories; Shop Tools; Warehouse & Dock products; Hand Tools; Air Tools

NOTE: JET is a division of JPW Industries, Inc. References in this document to JET also apply to JPW Industries, Inc., or any of its successors in interest to the JET brand.

2.0 Table of Contents

Section	Page
1.0 Warranty and Service.....	2
2.0 Table of Contents.....	3
3.0 IMPORTANT SAFETY INSTRUCTIONS.....	5
3.1 Machinery General Safety Warnings.....	5
3.2 General Electrical Cautions.....	6
3.3 Safety Instructions for Drill Presses.....	6
4.0 Specifications.....	7
4.1 Machining Capacities.....	7
4.2 Machine Environment.....	8
4.3 Power Supply Requirements.....	8
4.4 Overall Dimensions, J-1230R.....	9
5.0 General Features and Terminology.....	10
6.0 Set-Up and Assembly.....	12
6.1 Floor Diagrams for J-1230R.....	12
6.2 Unpacking.....	13
6.3 Machine Set-Up.....	14
6.4 Electrical Connections.....	15
7.0 Operating Controls.....	16
8.0 Operation.....	17
8.1 Clamping workpieces.....	17
8.2 Tool insertion.....	17
8.3 Tool Positioning over workpiece.....	17
8.4 Unlocking arm and column mechanisms.....	18
8.5 Raising and lowering radial arm.....	18
8.6 Moving drill head along arm.....	18
8.7 Rotating arm on support column.....	18
8.8 Setting spindle speed.....	18
8.9 Feed rate and depth of cut.....	19
8.10 Setting feed rate.....	19
8.11 Setting depth of cut using power feed system.....	20
8.12 Spindle direction and power feed.....	20
8.13 Hand feed – roughing operations.....	20
8.14 Fine hand feed using power feed system.....	20
8.15 Tapping.....	21
8.16 Power ON/OFF.....	21
8.17 Power ON light.....	21
8.18 Coolant control.....	21
8.19 Spindle motor controls.....	21
8.20 Turning off spindle drive.....	21
8.21 Resetting STOP switch.....	21
8.22 Using load ammeter.....	21
8.23 Tapping operations.....	21
8.24 Arm/spindle control lever.....	22
9.0 Adjustments.....	22
9.1 Clamping Device.....	22
9.2 Head/Rail Backlash.....	22
10.0 Spindle Speed Chart.....	24
11.0 Troubleshooting the J-1230R.....	25
12.0 Maintenance.....	26
12.1 General Cleaning.....	26
12.2 Lubrication.....	26
13.0 Replacement Parts.....	28
13.1.1 Riser Mechanism: Exploded View.....	28
13.1.2 Riser Mechanism: Parts List.....	29
13.2.1 Column and Base: Exploded View.....	30
13.2.2 Column and Base: Parts List.....	31
13.3.1 Arm (Front): Exploded View.....	32
13.3.2 Arm (Front): Parts List.....	33
13.4.1 Arm (Rear) and Clamping Gearbox: Exploded View.....	34

13.4.2 Arm (Rear) and Clamping Gearbox: Parts List.....	35
13.5.1 Coolant System: Exploded View	37
13.5.2 Coolant System: Parts List	37
13.6.1 Gearbox Assembly (Head): Exploded View	38
13.6.2 Gearbox Assembly (Head): Parts List	39
13.7.1 Rear of Head: Exploded View	42
13.7.2 Rear of Head: Parts List.....	43
13.8.1 Counterweight Assembly: Exploded View.....	44
13.8.2 Counterweight Assembly: Parts List.....	44
14.0 Electrical Connections for J-1230R.....	45
14.1 Electrical Connections for J-1230R: Parts List.....	46

Familiarize yourself with the following safety notices used in this manual:

⚠CAUTION This means that if precautions are not heeded, it may result in minor injury and/or possible machine damage.

⚠WARNING This means that if precautions are not heeded, it may result in serious or even fatal injury.



3.0 IMPORTANT SAFETY INSTRUCTIONS

- Misuse of this machine can cause serious injury.
- For safety, machine must be set up, used and serviced properly.
- Read, understand and follow instructions in the operator's and parts manual which was shipped with your machine.

When setting up machine:

- Always avoid using machine in damp or poorly lighted work areas.
- Always be sure machine is securely anchored to the floor.
- Always keep machine guards in place.
- Always put start switch in "OFF" position before plugging in machine.

When using machine:

- Never operate with machine guards missing.
- Always wear safety glasses with side shields (See ANSI Z87.1)
- Never wear loose clothing or jewelry.
- Never overreach — you may slip and fall into the machine.

- Never leave machine running while you are away from it.

-Always shut off the machine when not in use.

When servicing machine:

- Always unplug machine from electrical power while servicing.
- Always follow instructions in operator's and parts manual when changing accessory tools or parts.
- Never modify the machine without consulting JET.

Read and follow these simple rules for best results and full benefits from your machine. Used properly, JET machinery is among the best in design and safety. However, any machine used improperly can be rendered inefficient and unsafe. It is mandatory that those who use our products be properly trained in how to use them correctly. They should read and understand the Operating Instructions and Parts Manual as well as all labels affixed to the machine. Failure to follow all of these warnings can cause serious injuries.

3.1 Machinery General Safety Warnings

1. Always wear protective eye wear when operating machinery. Eye wear shall be impact resistant, protective safety glasses with side shields which comply with ANSI Z87.1 specifications. Use of eye wear which does not comply with ANSI Z87.1 specifications could result in severe injury from breakage of eye protection.
2. Wear proper apparel. No loose clothing or jewelry which can get caught in moving parts. Contain long hair. Rubber soled footwear is recommended for best footing.
3. Do not overreach. Failure to maintain proper working position can cause you to fall into the machine or cause your clothing to get caught — pulling you into the machine.
4. Keep guards in place and in proper working order. Do not operate the machine with guards removed.
5. Avoid dangerous working environments. Do not use stationary machine tools in wet or damp locations, or in an explosive environment. Keep work areas clean and well lit. Special electrics should be used when working on flammable materials.
6. Avoid accidental starts by being sure the start switch is "OFF" before plugging in the machine.
7. Machinery must be anchored to the floor.
8. Never leave the machine running while unattended. Machine shall be shut off whenever it is not in operation.
9. Disconnect electrical power before servicing. Whenever changing accessories or general maintenance is done on the machine, electrical power to the machine must be disconnected before work is done.
10. Maintain all machine tools with care. Follow all maintenance instructions for lubricating and the changing of accessories. No attempt shall be made to modify or have makeshift repairs done to the machine. This not only voids the warranty but also renders the machine unsafe.
11. Secure work. Use clamps or a vise to hold work, when practical. It is safer than using your hands and it frees both hands to operate the machine.
12. Never brush away chips while the machine is in operation.
13. Keep work area clean. Cluttered areas invite accidents.
14. Remove adjusting keys and wrenches before turning machine on.
15. Use the right tool. Don't force a tool or attachment to do a job for which it was not designed.
16. Use only recommended accessories and follow manufacturer's instructions pertaining to them.
17. Keep hands in sight and clear of all moving parts and cutting surfaces.
18. All visitors should be kept a safe distance from the work area. Make workshop completely safe by using padlocks, master switches, or by removing starter keys.
19. Know the tool you are using; its application, limitations, and potential hazards.

3.2 General Electrical Cautions

This machine should be grounded in accordance with the National Electrical Code and local codes and ordinances. This work should be done by a qualified electrician. The machine should be grounded to protect the user from electrical shock.

Caution: For circuits which are far away from the electrical service box, the wire size must be increased in order to deliver ample voltage to the motor. To minimize power losses and to prevent motor overheating and burnout, the use of wire sizes for

branch circuits or electrical extension cords according to the following table is recommended:

Conductor Length	AWG Number	
	240 Volt Lines	120 Volt
0 – 50 Ft.	No. 14	No. 14
50 – 100 Ft.	No. 14	No. 12
Over 100 Ft.	No. 12	No. 8

Table 1

3.3 Safety Instructions for Drill Presses

1. All work shall be secured using either clamps or a vise to the drill press table. It is unsafe to use your hands to hold any workpiece being drilled.
2. Drill press head and table shall be securely locked to the column before operating the drill press. This must always be checked prior to starting the machine.
3. Always use the correct tooling. Tooling shall always be maintained and properly sharpened. All tooling must be run at the proper speeds and feeds as they apply to the job. Use only recommended accessories and follow those manufacturer's instructions pertaining to them. Tooling shall not be forced into any workpiece but fed according to the proper specifications. Failure to follow these instructions will not only ruin the tooling as well as the machine, but can cause serious injury.
4. Never brush away shavings or chips while the machine is in operation. All clean up should be done after the machine is stopped.
5. Keep hands in sight. Do not put hands or fingers around, on, or below any rotating cutting tools. Leather safety gloves should be used when handling any sharp objects or cutting tools. See Figure A.
6. Always wear protective eye wear when operating, servicing or adjusting machinery. Eyewear shall be impact resistant, protective safety glasses with side shields complying with ANSI Z87.1 specifications. Use of eye wear which does not comply with ANSI Z87.1 specifications could result in severe injury from breakage of eye protection. See Figure B.
7. When drilling in material which causes dust, a dust mask shall be worn. See Figure C.
8. Avoid contact with coolant, especially guarding the eyes.
9. Non-slip footwear and safety shoes are recommended. See Figure D.
10. Wear ear protectors (plugs or muffs) during extended periods of operation. See Figure E.

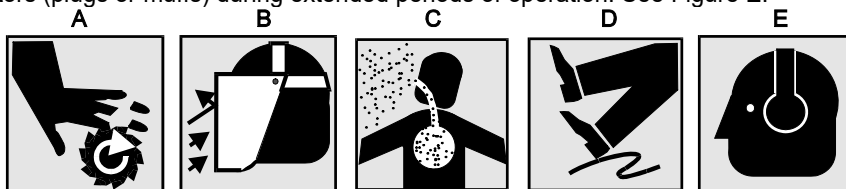

Figure 1

⚠ WARNING: This product can expose you to chemicals including lead and cadmium which are known to the State of California to cause cancer and birth defects or other reproductive harm, and phthalates which are known to the State of California to cause birth defects or other reproductive harm. For more information go to <http://www.p65warnings.ca.gov>.

⚠ WARNING: Some dust, fumes and gases created by power sanding, sawing, grinding, drilling, welding and other construction activities contain chemicals known to the State of California to cause cancer and birth defects or other reproductive harm. Some examples of these chemicals are:

- lead from lead based paint
- crystalline silica from bricks, cement and other masonry products
- arsenic and chromium from chemically treated lumber

Your risk of exposure varies, depending on how often you do this type of work. To reduce your exposure to these chemicals, work in a well-ventilated area and work with approved safety equipment, such as dust masks that are specifically designed to filter out microscopic particles. For more information go to <http://www.p65warnings.ca.gov/> and <http://www.p65warnings.ca.gov/wood>.

4.0 Specifications

The JET Model J-1230R is a powerful and versatile radial arm drill press. The drill head is mounted on an arm and can slide along the arm to position the spindle over the work piece. The arm itself can be rotated on its support column to allow centering the spindle over the work piece.

Drilling can be performed manually or with power feed assistance. In addition, parameters of RPM, power feed rate and drilling depth can be pre-set by the operator, using controls conveniently positioned on the drill head.

The power train gears and spline shaft are made of high quality heat-treated and ground nickel chrome steel, offering greater strength and smoothness to high-torque loads. The spindle is of case hardened steel and supported by dual row taper roller and thrust ball bearings at the nose, with thrust and axial bearings at the top. The frame is made of Meehanite® and high-tensile strength cast iron.

A precision machined box table allows convenient positioning and clamping of smaller work pieces. The box table can be removed from the base to allow larger workpieces to be clamped on the base itself. Both table and base have multiple T-slots for clamping set-ups.

Model number J-1230R
(J-1230R-4 is the same machine but wired for 460V operation)

Stock numbers:

J-1230R 320036
 J-1230R-4 320037

Head and Spindle:

Push button controls 110V
 Spindle motor (*model J-1230R*) TEFC, 5/3 HP (3.7/2.2kW), 3 PH, **230V only**, 13/18 A, 60Hz
 Spindle motor (*model J-1230R-4*) TEFC, 5/3 HP (3.7/2.2kW), 3 PH, **460V only**, 6.6/7.5 A, 60Hz
 Spindle taper Morse No. 4
 Spindle speeds twelve speeds, within 45-1550 RPM
 Quill (spindle) travel 9-7/8 in. (247mm)
 Quill (spindle) travel with powerfeed engaged 9-7/16 (240mm)
 Spindle travel along arm, total 35 in. (875mm)
 Feed rates (distance per revolution) 0.002, 0.004, 0.006 in/rev
 Base surface to spindle, maximum (no tooling) 54 in. (1350mm)
 Base surface to spindle, minimum (no tooling) 19-3/8 in. (484mm)
 Column to spindle center distance, maximum 46 in. (1170mm)
 Column to spindle center distance, minimum 13-3/8 in. (334mm)
 Sound level (approx. 3-1/4 ft./1m from gearbox) * 82 dB at 1500 rpm; 79 dB at 88 RPM

Arm and Column:

Column diameter 11-13/16 in. (300mm)
 Arm vertical travel on column 34-5/8 in. (880mm)
 Arm elevating motor TEFC, 1 HP (0.75kW), 3 PH, 230/460V, 3.2/1.6A, 60Hz
 Clamping motor TEFC, 1 HP (0.75kW), 3 PH, 230/460V, 3.2/1.6A, 60Hz

Base and Table:

Box table dimensions (LxWxH) 25 x 20-1/2 x 16-1/2 in. (635 x 520 x 419mm)
 T-slots in Table five at 3/4 in. (19mm)
 Base dimensions (LxWxH) 68 x 28 x 7 in. (1710 x 715 x 180mm)
 T-slots in Base three at 3/4 in. (19mm)

Additional specifications:

Coolant pump motor TEFC, 1/8 HP (0.1kW), 3 PH, 220/440V, 0.2/0.1A, 60Hz
 Machine height (floor to motor at maximum elevation) 109-1/2 in. (2780mm)
 Shipping Dimensions (LxWxH) 80 x 39 x 88 in. (2035 x 995 x 2240mm)
 Net weight 4,630 lbs/2100kg
 Shipping weight 5,070 lbs/2300kg

* Measured under test conditions SS41 material, 32mm thick, Ø32mm tool.

4.1 Machining Capacities

	Drilling	Tapping	Boring
Mild Steel	1-7/8 in. (47.63mm)	1" (25.4mm)	3-3/8" (84mm)
Cast iron	2-5/16 in. (58.75mm)	1-1/2" (38.1mm)	4-3/4" (119mm)

Table 2

4.2 Machine Environment

1. Do not position the machine where it receives direct sunlight.
2. Normal ambient temperature should be between +5°C (41°F) and 40°C (104°F).
3. Humidity: Between 30% and 95%. At maximum temperature of 40°C/104°F, relative humidity should not be over 50%. Higher humidity is acceptable at relative lower temperatures (e.g. 90% humidity at 20°C).
4. Keep machine away from gasoline, chemical substances, dust, acid, sulfides, magnetic interference and explosive environments.
5. Keep machine away from electrical interference sources such as welding machines and EDM (Electric Discharge Machining).
6. Illumination of work area should be greater than 500lux.
7. Work area must have adequate ventilation.

4.3 Power Supply Requirements

1. Acceptable voltage fluctuation: normally +/- 10%
2. Acceptable frequency fluctuation: +/- 1Hz (50/60Hz)
3. Acceptable momentary power-off duration: less than 10m.sec
4. Acceptable voltage impulse:
 - Peak value: 200% or less than the line voltage of the actual value (rms.value).
 - Duration: 1.5m.sec or less.
5. Acceptable AC voltage of the waveform distortion.
6. Acceptable imbalance of the line voltage: 5% or less.

4.4 Overall Dimensions, J-1230R

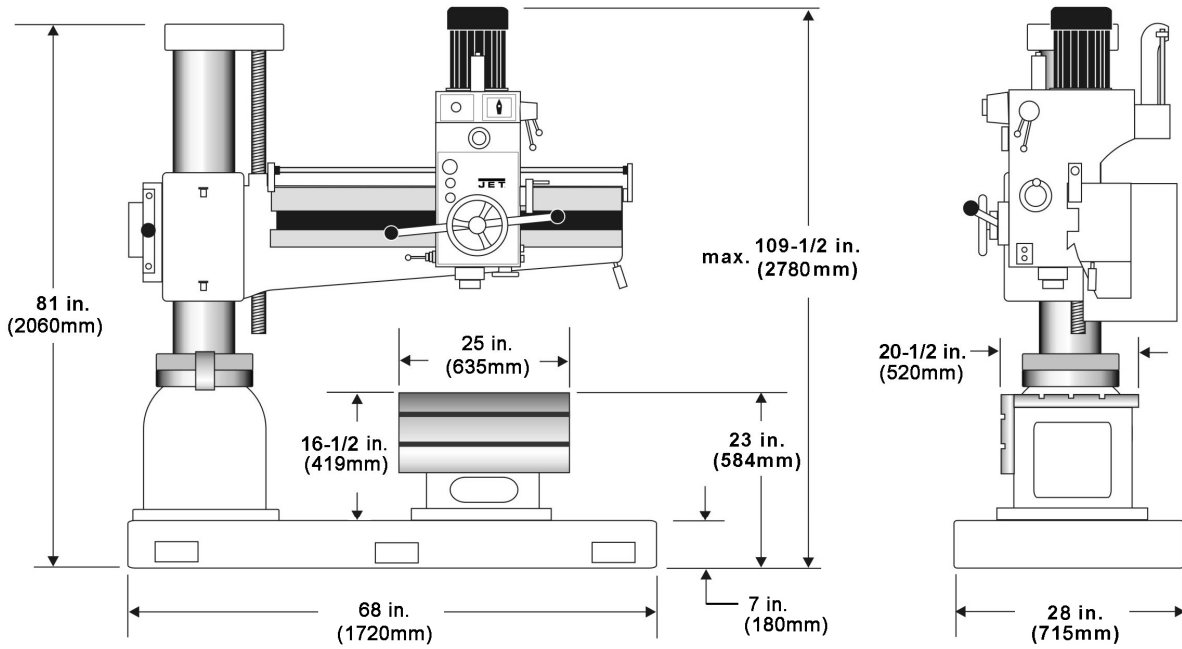

Figure 2

The specifications in this manual were current at time of publication, but because of our policy of continuous improvement, JET reserves the right to change specifications at any time and without prior notice, without incurring obligations.

5.0 General Features and Terminology

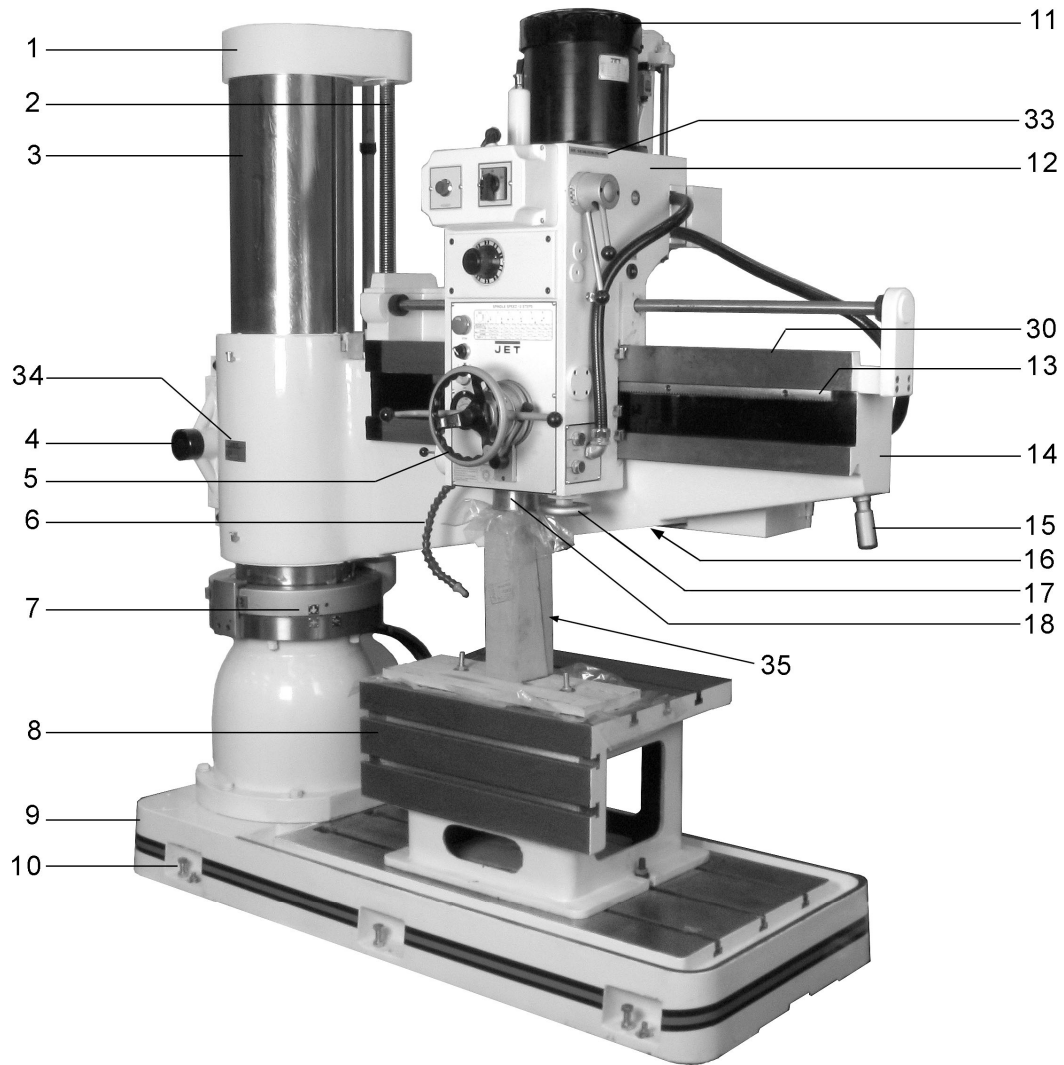

Figure 3

- | | |
|--|--|
| 1. Top Cap | 19. Work Lamp Toggle Switch |
| 2. Elevating Ball Screw | 20. Electrical cabinet |
| 3. Column | 21. Counterweight System |
| 4. Locking Nut | 22. Clamping Rod |
| 5. Handwheel (horizontal gearbox travel) | 23. Guard Panel |
| 6. Coolant Nozzle | 24. Clamping Gear |
| 7. Column Clamping Indicators | 25. Coolant Pump |
| 8. Box Table | 26. Arm Raising Motor |
| 9. Base | 27. Clamping Motor |
| 10. Leveling Screws | 28. Clamping Gearbox |
| 11. Spindle Motor | 29. Elevating Worm Gear Reducer |
| 12. Drill Head/Gearbox (see Figure 10 for details) | 30. Arm Rail |
| 13. RaCK | 31. Caution Label – High Voltage (p/n CL-HV) |
| 14. Arm | 32. Warning Label – Tipping Risk (p/n J1230R-WL) |
| 15. Arm Rotation Handle | 33. Caution Label – Stop Spindle (p/n J1230R-CL) |
| 16. Work Lamp | 34. Machine Identification Plate |
| 17. Fine Feed Handwheel | 35. Support Block (for shipping only) |
| 18. Spindle | |

General Features and Terminology (cont.)

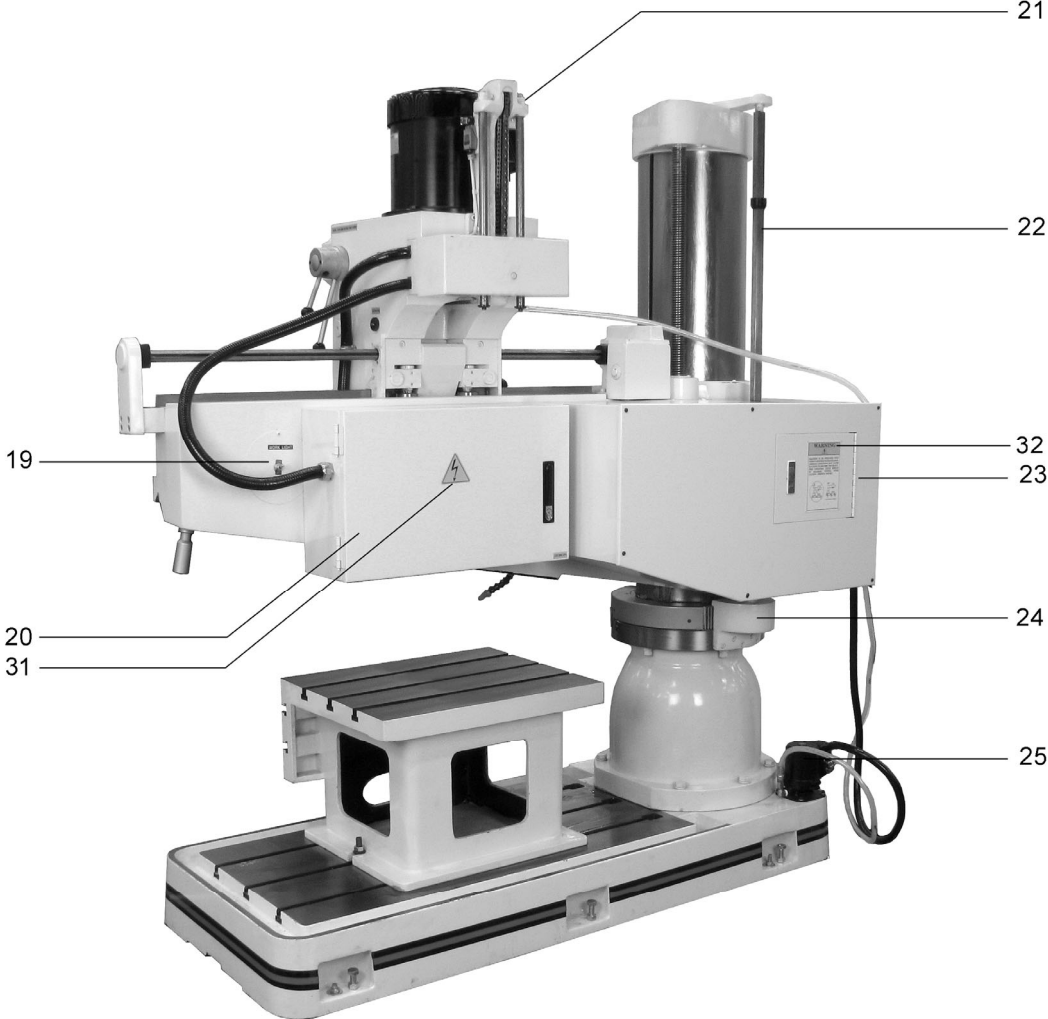

Figure 4

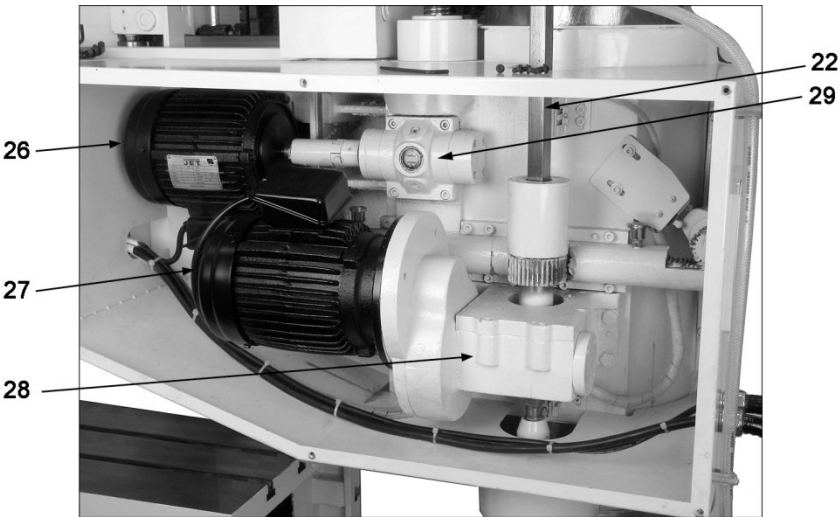

Figure 5

6.0 Set-Up and Assembly

6.1 Floor Diagrams for J-1230R

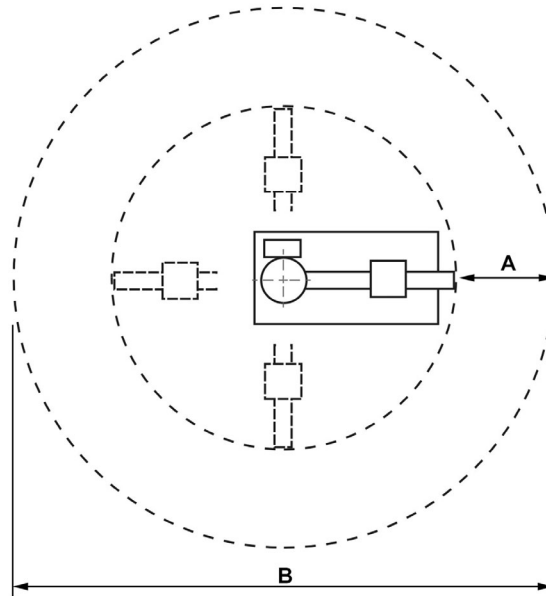

Figure 6

Figure 4 shows spacing for the 360° rotational path of the arm, plus 1000mm (approx. 40 inches) of general maintenance area on each side.

Distance column center to arm limit	Maintenance area (A)	Total space required (B)
1546mm (61 in.)	1000mm (40 inches)	5092mm (200 in.)

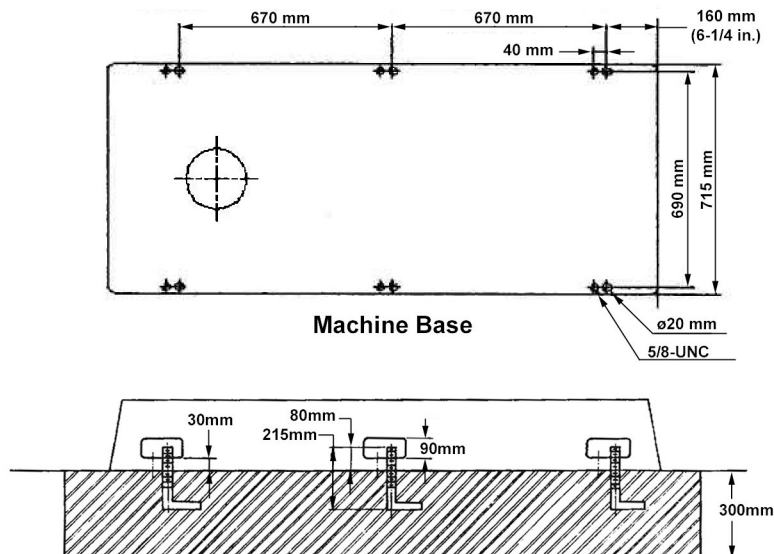

Figure 7

6.2 Unpacking

Remove any remnants of the shipping crate and check for shipping damage. Report any damage immediately to your distributor and shipping agent. Do not discard any shipping material until the Radial Arm Drill Press is installed and running properly.

Compare the contents of your container with the following parts list to make sure all parts are intact. Missing parts, if any, should be reported to your distributor. Read the instruction manual thoroughly for assembly, maintenance and safety instructions.

Contents of Shipping Container

(Figure 9)

- 1 Radial Arm Drill Press (not shown)
- 6 Leveling Pads
- 1 Tool Box, containing:
 - 1 Grease gun
 - 1 Oil bottle
 - 1 Tapered Drift
 - 1 Adjustable wrench
 - 1 Set of hex keys
 - 1 Flat blade screwdriver
 - 1 Cross point screwdriver
- 1 Instructions and Parts Manual (not shown)
- 1 Warranty Card (not shown)
- 1 Manufacturer's Test Chart (not shown)



Figure 8

⚠WARNING

Read and understand the entire contents of this manual before attempting set-up or operation! Failure to comply may cause serious injury.

6.3 Machine Set-Up

1. After dismantling the crate, remove the toolbox and any accessory items from around the machine.
2. Place lifting straps as shown in Figure 9. Use cushioning to protect machine surfaces.

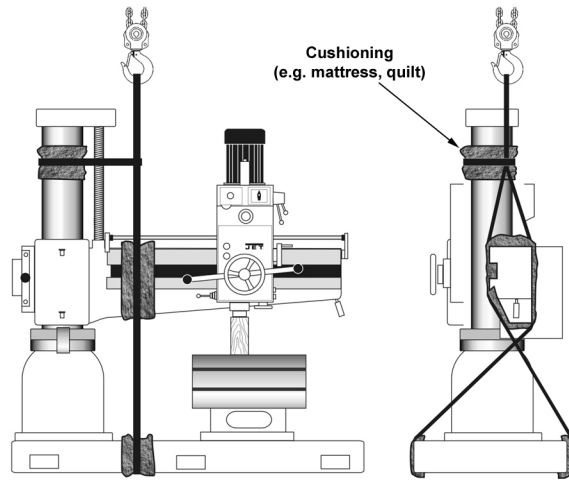

Figure 9

3. Remove the bolts holding the machine to the skid.

⚠ WARNING All lifting equipment must be rated appropriately to safely sustain the weight of the drill press. Do not allow anyone near or beneath the machine while it is being moved.

4. Lift the machine and position it over the anchor bolts in an area with good lighting, and a level and well-supported floor.
5. Place the leveling pads beneath the level adjusting bolts. Place a level (its tolerance should be within 0.02mm/m) on the box table and level the machine.
6. The drill press **MUST** be anchored to the floor. Use the layout diagram in Section 6.1 as a guide, and mount the nuts to the ground bolts.

⚠ WARNING Failure to anchor the machine properly, according to the diagrams, could result in the machine tipping over and consequent damage to the machine and possible injury to the machine operator and bystanders.

7. Connect the electrical service branch to the machine according to the instructions which follow in section 6.4 *Electrical Connections*. This work should be done only by a qualified and licensed electrician who is familiar with machine service and national and local codes.

8. Turn on the drill press (see Section 8.0 *Operation*), push the unlock button, and move the arm elevation lever to UP, until the quill clears the shipping block. Remove shipping block and wood platform from the box table.
9. Wipe the surfaces of the machine which have been treated with a protective coating, using mineral spirits or a cleaner/degreaser.
10. Inspect all sight glasses on the machine to be certain they are filled to their level lines. If low, add fluid as necessary according to instructions in Section 11.2 *Lubrication*.
11. Perform a lubrication check at all points recommended in Section 11.0.
12. Follow directions in Section 8.0 *Operation* to check all operation functions of the drill press. If coolant is being used, put coolant in the sump and test coolant delivery.
13. When all of the above operations are complete, the machine is ready for service.

6.4 Electrical Connections

⚠WARNING Electrical set-up should be performed only by a licensed electrician who is familiar with national and local electrical codes. This machine must be properly grounded to help prevent electrical shock and possible fatal injury.

Model J-1230R radial drills are tested before shipping, for all functions and circuits under electrical power specified for the machine and motors. The only hook-up requirement should be for correct connection to an appropriate cutout on an appropriate service branch.

Where the following instructions do not agree with local electrical codes and procedures, the applicable codes and procedures should be followed, exclusively.

Wiring diagram

A wiring diagram for the drill press is found inside the door of the electrical cabinet. It is also shown at the back of this manual. This diagram is for reference by your licensed installing or servicing electrician. In addition to using a licensed electrician for connection to the drill press service branch, the servicing of components and circuits inside the control box should be serviced only by a qualified electrician. This includes fuse replacement, if required. If any of these fuses, upon replacement, should continue to fail at short service intervals, the electrician should be asked to check all machine components for excessive loads, short circuits or other failures.

Electrical branch service

The machine is wired for either a 230V or 460V 3-phase service branch. The cable supplying the drill press will be tagged with the voltage at which the machine was tested and corresponding to the customer's order.

If the tag has been lost, it will be necessary for you to open the electrical cabinet on the rear of the drill press and examine the connections on the transformer found inside the box. The transformer can be connected to either a 230 or 460 volt source and its taps are labeled for voltage. By locating the source tap on the transformer you will be able to determine the branch voltage required.

A service disconnect is recommended. The use of fuses or circuit breakers for each of the voltage supply wires is required. Use fuses or circuit breakers which are appropriate to the voltage for the motor system delivered.

A positive cut-out/lock-out lever or rocker switch should be located on the outside of the service disconnect to allow the machine operator to disconnect from the branch circuit when working with tooling on the machine.

It is recommended that the **230 volt** Drill Press be connected to a dedicated 25 amp circuit with a 25 amp circuit breaker or time delay fuse. Connect the **460 volt** drill press to a dedicated 15 amp circuit with 15 amp circuit breaker or time delay fuse. **Local codes take precedence over recommendations.**

Connecting branch to drill press

1. Disconnect the service branch to the machine by moving the lever or rocker switch on the cutout box to OFF.
2. Connect the green wire (or green with white trace) to the branch ground.
3. Connect the remaining three wires in the cable (labeled R, S and T) to the three power lines in the branch.
4. Turn the power to the machine ON at the cutout box.
5. Turn the coolant switch (See Figure 10) to the ON position.

⚠CAUTION Make sure there is coolant in the flood coolant system before operating the pump.

6. Observe the rotation through the glass atop the pump. The shaft should be rotating in the direction of the arrow cast into the pump assembly. If the shaft is rotating the wrong direction, the power leads need to be switched. Correct as follows:
7. Disconnect power to the machine by turning it off at the cutout box.
8. Reverse *any two* of the power lead connections.
9. Repeat steps 4, 5, and 6, above, and you should observe the pump shaft turning in the proper direction. The electrical service to the machine is now complete.

8.0 Operation

8.1 Clamping workpieces

To load/unload heavier workpieces, unlock the arm and rotate it out of the way. Lift the workpiece with slings or other properly rated lifting equipment.

Both the box table and the base surface are slotted to accept a suitably sized T-slot clamp. Before beginning any work on the drill press, anchor the work piece, and the box table if used, to be certain that the workpiece and/or box table will not move when the tool enters the workpiece.

If the box table will not be used, simply remove the nuts at the base, and move the table off using proper lifting equipment.

⚠WARNING Failure to properly anchor workpiece and box table could result in damage to machine, damage to workpiece, and severe injury to machine operator. Never work on the drill press without clamping the materials using a T-slot system set-up.

8.2 Tool insertion

The Model J-1230R uses a No. 4 Morse taper in the spindle to secure tooling. Any drill, milling cutter, or tool holder with an MT-4 can be inserted into the quill.

⚠CAUTION The first step in removing or inserting any tooling is to **be absolutely certain the machine cannot be accidentally started during the insertion or removal operation.** The only way to be certain of this fact is to disconnect power to the machine. The service box should have a cut-out switch or lever on the outside of the box. Put the switch or lever in the OFF position before inserting or removing tooling.

To insert tooling:

1. Verify that machine is disconnected from power.
2. Be certain the spindle is clean, free from oil, and ready to accept the shank of any tooling.
3. Check the shank of the tooling to be certain the tooling is free from dirt, nicks or burrs. If nicks or burrs are discovered, file or stone the shank until it is smooth.
4. Be certain quill is in full UP position.
5. Slide shank of tooling into the spindle until it seats.
6. Use a soft-faced mallet (such as lead, plastic, brass, etc.) to give the tooling a sharp tap on its tip. This will secure the tooling in the taper.
7. Reestablish power to the machine and the drill is ready to use.

To remove tooling:

8. Verify that machine is disconnected from power.
9. Place a wood block under the tooling in the spindle, to prevent it being damaged should it fall out during the removal process.
10. Lower the quill using the feed levers until the tool removal window is exposed.
11. Insert tapered drift (included in toolbox) into the removal window, above the tip of the tooling shank.
12. Use leather gloves to hold the tooling with your hand to prevent it falling from the quill.
13. With your free hand, tap the tapered drift with a hammer until the tooling can be removed.

8.3 Tool Positioning over workpiece

After the workpiece has been clamped to the base or table, position the tooling over the workpiece, using any or all of the following methods:

1. Adjusting the height of the arm on the support column.
2. Moving the drill head along the arm.
3. Rotating the column upon which the arm and head are attached.

8.4 Unlocking arm and column mechanisms

A motorized locking system is used to lock the head to the arm, the arm to the column, and the column to the base.

When you push UNLOCK, *all* of the locks are unlocked. When you push LOCK, *all* of the locks are locked.

The buttons which control the locks are located on the right-hand side of the drill head (see Figure 10). Press and hold the UNLOCK button until the arrow (Figure 11) points to “B”. Release the button. The clamping device is now disengaged. When locking, press and hold the LOCK button until the arrow points to “A”. The clamping device is now re-engaged.

CAUTION Always be certain the locks are engaged before using the drill press. Pull on the arm handle and try to rotate the handwheel at the front of the head, before starting the spindle. Failure to have all locks secure may result in damage to tooling, damage to workpiece, and possible injury to the operator.



Figure 11

8.5 Raising and lowering radial arm

1. Power to the drill press must be ON – then release the machine locks by pushing the UNLOCK button.
2. Raise or lower arm to required height using the arm/spindle control lever (see Figure 10). See also Section 8.24 *Using the control lever*.
3. When the arm is at required height and if no other adjustments to spindle location are required, press the LOCK button to secure all machine locks.

8.6 Moving drill head along arm

1. Power to the drill press must be ON – then release the machine locks by pushing the UNLOCK button.

2. Turn handwheel to move the drill head along the arm. See Figure 10.
3. When drill head is at desired position on the arm and if no other adjustments to spindle location are required, push the LOCK button to secure all machine locks.

WARNING NEVER swing the drill press arm on the support column unless you are absolutely certain the drill press base is firmly attached to the shop floor. If the arm is moved off its position directly above the base and the base is not bolted to the floor, **THE DRILL MAY TIP OVER AND CAUSE SERIOUS INJURY TO THE DRILL PRESS OPERATOR**, and will certainly result in damage to the drill press itself.

8.7 Rotating arm on support column

1. Power to the drill press must be ON – then release the machine locks by pushing the UNLOCK push button.
2. Swing the arm using the handle (see Figure 10) to required spindle position.
3. When the spindle is positioned correctly and no other adjustments are required, push the LOCK button to secure all machine locks.

8.8 Setting spindle speed

Spindle speeds are established using the gear change levers on the upper right-hand side of the drill head (See Figure 10). The shorter of the two levers operates a two-speed mechanism which puts the gearbox in either high gear or low gear. A HI/LOW indicator on the upper left hand side of the drill head identifies the selected speed range.

The longer gear change lever operates a three speed gearbox mechanism. A detent in the middle of the lever travel indicates when the lever is in intermediate gear position.

This gearbox set-up gives you a total of six spindle speeds which may be selected. The two-speed spindle drive motor, therefore, increases the number of available speeds to 12. The speed selected clearly depends on the position of *both gear change levers* and whether the *motor switch* on the top front of the drill head is on LOW or HI speed.

A table on the front of the drill head shows gear change lever and motor switch values required to select each speed. A similar table is included in Section 10.0 of this manual.

On the gear change table you will also find the recommended drill sizes for the various speeds which are selectable. **These recommendations are only approximate.** With the wide variety of drill types and coatings available, as well as cutting fluids, and the even wider variety of work piece materials which you might be machining – you

need to consult with your tooling, coolant and/or work piece suppliers to determine the best spindle speed to use for any specific drilling operation.

CAUTION Do not try to change gears while the spindle is turning. This may cause serious damage to the spindle drive system.

Allow the spindle to stop completely before attempting to change gears. If the gear change lever you want to move does not slip easily into the new position, jog the motor for a second using the control lever. Then allow the spindle to come to a stop before attempting to change gears again. Repeat this jogging process, as necessary, until the gears match up properly for changing.

CAUTION Plan for quill movement during high speed spindle rotation. High speed rotation without quill travel will increase spindle temperatures.

8.9 Feed rate and depth of cut

The J-1230R has limit switches on the quill which cut power to the drive motor when the quill has reached either the upper or lower limit of its travel. This system is designed to prevent gearbox damage if the power feed mechanism is engaged – damage which would occur if the quill were to bottom out against the upper or lower limit of quill travel. In the event of failure of either limit switch there is also a safety clutch mechanism which will slip when travel limits are reached.

However, while you are able to use virtually the full travel of the quill for drilling or other operations, the drill press operator typically sets both the rate of feed (travel-per-revolution of the spindle), and the depth of cut (quill travel to make the required cut).

These two operations are described here:

8.10 Setting feed rate

The feed rate is set using the knob and dial on the front of the drill head. See Figure 12. The knob can be rotated to select any of three different feed rates, plus a neutral position where the power feed does not operate on the quill.

CAUTION Do not try to change feed rate while the spindle is turning. This may cause serious damage to the spindle drive system.

It is recommended that when doing operations not requiring power feed that the dial be set to neutral. This minimizes any wear on the power feed mechanism.

Feed rate selection is indicated by a pair of rivet heads (A, Figure 12) on opposing edges of the dial. These values are indicated in smaller type on the outer edge of the dial plate.

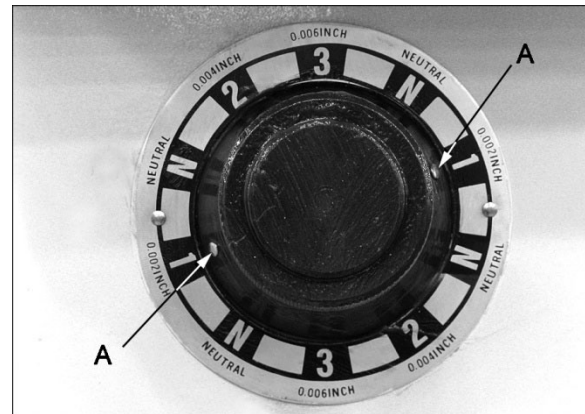

Figure 12

Any of the three feed rates are available for selection using any of the spindle speeds available. There will be a recommended feed rate for any drilling or boring operation, and this rate must be determined by consulting appropriate machining handbooks or by consulting with your tooling and work piece suppliers.

8.11 Setting depth of cut using power feed system

There is a mechanism for engaging power feed and there is also a "trip" mechanism which can be set to disengage the power feed when a pre-set depth has been reached.

The feed levers (A, Figure 13) can be pulled outward or pushed inward on pivots in the feed lever hub. When the levers are pushed toward the drill head, the power feed mechanism is disengaged. When the feed levers are pulled outward, the power feed system is engaged. In the power feed position (outward) the quill and spindle will be driven until one of the following happens:

- Spindle reaches limit of travel and the limit switches disable power; or
- The "trip" mechanism automatically disengages the power feed; or
- The drill press operator pushes the feed levers into the disengaged position.

To set depth of cut:

Refer to Figure 13.

1. Rotate feed levers (A) counterclockwise to lower the drill until it just contacts the work piece. Drill-to-workpiece contact represents zero depth position.
2. Push lever (B) to unlock depth control.
3. Rotate dial (D) until the indicator (E) is at the feed depth required on the scale (C).
4. Push lever (B) to lock depth setting.
5. Pull feed levers (A) outward to engage power feed clutch.

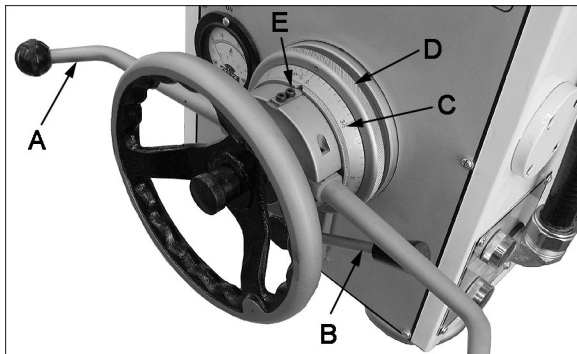

Figure 13

Note: Because the dial (D) makes one rotation before contacting the mechanical trip dog, you are limited to 4 inches (100mm) of travel during any power feed operation when using this dial depth stop system. If you need to make deeper holes, you must do the machining in steps.

Power feed is used only for drilling, not for threading. Feed rate must be set (off neutral) for power feed to be engaged.

8.12 Spindle direction and power feed

Spindle rotation direction is managed by the arm/spindle control lever on the left hand side of the drill head. See Figure 10.

Clockwise or "forward" rotation is the direction of rotation for right-hand tooling – the vast majority of tooling used in machine operations. Reverse spindle rotation for left hand tooling.

Power feed direction is determined by the spindle direction. When spindle is set to its most common direction – clockwise or forward – the quill and spindle are driven downward. When spindle direction is set counterclockwise (reverse), quill and spindle are driven upward.

8.13 Hand feed – roughing operations

When the feed levers are pushed toward the drill head the power feed mechanism is disengaged. In this position, the feed levers can be used to move the quill and spindle and perform manual drilling or other machining operations.

8.14 Fine hand feed using power feed system

The fine feed control wheel is located on the underside of the right-hand side of the drill head. See Figure 10. The fine feed control is used as follows:

1. Set feed rate dial to N (neutral).
2. Pull feed levers out to engage power feed clutch.
3. Turn on drill press, and set arm/spindle control lever to desired direction.
4. Turn fine feed control wheel by hand. Quill and spindle will move downward or upward (depending upon which way you turn the wheel and the direction the spindle is turning) until you stop turning the control wheel.

8.15 Tapping

1. Insert screw tap into spindle.
2. Move spindle into position.
3. Set spindle control to Forward.
4. Rotate the feed levers counterclockwise until desired tapping depth is reached.
5. Reverse spindle direction and allow tap to withdraw completely from workpiece.
6. Stop spindle by moving spindle control switch to center.

8.16 Power ON/OFF

If your J-1230R was connected to its service branch correctly, there will be a service disconnect with an external power cutoff lever or switch which disconnects the drill press from the service branch. This is your ultimate protection against accidental machine start-up when clamping work pieces or inserting and removing tooling. Always be certain you have turned off power at this disconnect before beginning such procedures.

8.17 Power ON light

When the cutout box power is ON, the red POWER light on the upper left hand side of the drill head (Figure 10) will be lit. In this mode, power to the coolant pump and to the spindle drive motor is controlled by the switches on the control console.

8.18 Coolant control

The flood coolant system is controlled by the dial on the front of the gearbox (Figure 10). If coolant has been turned on, but does not flow, check the pump rotation by observing the pump shaft. It should be rotating in the direction of the arrow on the pump casting. If rotation is incorrect, see Section 6.4 *Electrical Connections*, for more information.

Open the valve to the coolant nozzle using the handle at the left of the head (see Figure 10). The proximity of the nozzle can be adjusted by loosening the two knobs and sliding the coolant pipe up or down as needed. Retighten knobs.

8.19 Spindle motor controls

Power to spindle motor is controlled as follows:

1. The cutout box control lever must be in the ON position.
2. The motor speed control switch must be in either HI or LOW position.
3. The Emergency Stop switch must be disengaged.

4. The arm/spindle control lever must be engaged for selected rotation. See Section 8.24 *Arm/spindle control lever*.

8.20 Turning off spindle drive

To turn power OFF on the spindle drive motor do one of the following:

1. Put the two speed motor switch in OFF position, OR...
2. Put arm/spindle control lever in neutral, OR...
3. Push red STOP switch, OR...
4. When servicing the tooling or other machine components, put the service disconnect lever in OFF position.

Once the STOP switch has been pushed (step 3 above) none of the other switches on the panel can be used to control power to the spindle drive motor or coolant pump until the STOP switch has been reset.

8.21 Resetting STOP switch

Turn the Stop switch clockwise in the direction of the arrow on the red button. The switch is re-set and the other spindle motor controls can be used.

8.22 Using load ammeter

An ammeter on the control console is used to monitor the load on the spindle drive motor. It is connected into one of the three power lines which supply the main drive motor.

When the drive motor is ON and up to speed, and there is no tooling being used to drill, tap or bore a hole, the ammeter should read approximately 2.5 amps. If it exceeds this value there is a problem internally (such as lack of lubrication in the gearboxes, bad bearings, etc.). You should turn off the machine and determine the cause of any excessive free-running load.

Monitor the ammeter during machining operations. The ammeter should stay below 9 amps of current draw during machining. You should adjust spindle speed, feed rate and coolant use to maintain full load current draw below the 9 amp value.

If you exceed 9 amps current draw a thermal overload switch in the electrical control panel will trip. If this occurs, locate and reset the thermal switch.

8.23 Tapping operations

1. Determine the most efficient tapping speed (spindle speed) by consulting appropriate machinist's tables, your tap supplier, coolant supplier and/or workpiece supplier.
2. Be certain that feed rate dial is at neutral. See Section 8.10 *Setting feed rate*.

3. Turn on spindle motor. Also, turn on the coolant pump if coolant is being used.
4. Move arm/spindle control lever to *Forward*.
5. Use the feed levers to move the tap into its pilot hole until the tap makes its initial thread cut and is engaged in the work piece.
6. Allow the tap to "self-feed" into the pilot hole until it has completed its tapping operation.
7. Move arm/spindle control lever to neutral and allow spindle to stop completely.
8. Move arm/spindle control lever to reverse, so that tap unscrews itself from the hole it has just threaded.

8.24 Arm/spindle control lever

The four-position arm/spindle control lever is located on the left hand side of the drill head console. See Figure 10. It controls spindle rotation direction and raising and lowering of the arm.

The ability to control the height of the arm is available when:

1. The main power to the machine is ON at its branch service panel.
2. The emergency STOP switch is disengaged.
3. The arm/spindle control lever is pushed up or down.
4. The column and arm UNLOCK button (right hand side of the drill head – see Figure 10) is pressed to disengage the machine locks.

NOTE: The control lever does not return to neutral when released, but remains in position. This means unless you return it to neutral, the arm will keep raising or lowering until it contacts a limit switch.

9.0 Adjustments

After extended use – usually several years – the radial arm drill may require adjustment of certain parts. Two areas require particular attention:

- The clamping device.
- The gap between head and rail.

9.1 Clamping Device

If there is backlash in the clamping device, correct as follows.

Refer to Figure 14.

1. Press and hold the *unlock button* (see Figure 10) until the arrow (Figure 14) points to "B". Release the button. The clamping device is now disengaged.
2. Loosen the five *locking nuts* (C).

3. Turn the five upper *adjusting nuts* (D) counterclockwise (i.e. tighten them up against the clamping ring) approximately 180°.
4. Re-tighten the five locking nuts (C).
5. Press and hold the *lock button* until the arrow returns to (A). The clamping device is now engaged.

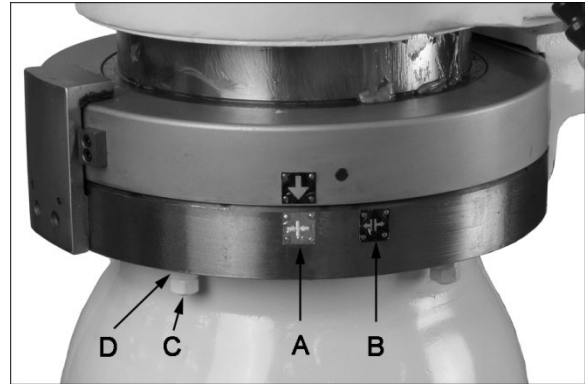

Figure 14

6. Move arm/spindle control lever to Arm UP.
7. Press emergency stop button after the arm has elevated a short distance.
8. Press the unlock button to release the clamping device.
9. Adjust the nut (E, Figure 15) one notch clockwise.
10. Move arm/spindle control lever to neutral.
11. Reset emergency stop button.



Figure 15

9.2 Head/Rail Backlash

If backlash ever appears between the gearbox head and the arm rail, the tightness between rail and bearings can be corrected, as follows.

Refer to Figure 16.

1. Remove side plate (F) by removing screws.
2. Loosen set screws (G).
3. Insert hex key into holes (H), and rotate the bearing shaft. Rotate handwheel on the front of the head; it should be snug but still easily turned.

4. Tighten set screws (G).
5. Repeat steps 1 through 4 for opposite side of the head.
6. Back at the original side of head, loosen set screws (I).
7. Insert hex key into hole (J) and rotate bearing shaft. Test the handwheel tightness again. When satisfied, retighten set screws (I).
8. Repeat steps 6 and 7 for opposite side of the head.
9. Install side plates (F) on both sides of head.

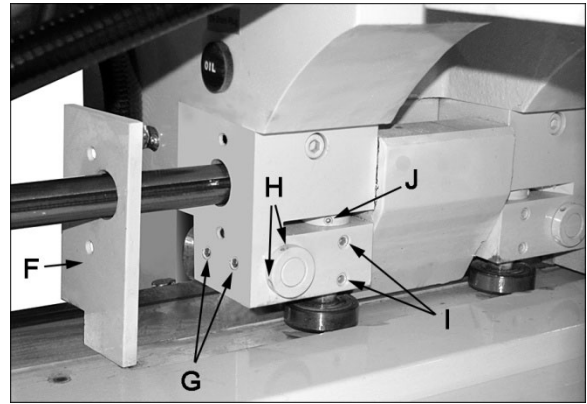

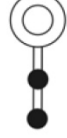



Figure 16

10.0 Spindle Speed Chart

Note: A similar chart is found on the front of the drill head.

12-Step Spindle Speed Settings for J-1230R Radial Arm Drill		1 		2 		3 	
		LOW	HIGH	LOW	HIGH	LOW	HIGH
Speed (RPM)	60Hz	44	88	77	154	141	282
	50Hz	37	74	64	129	118	236
Suitable drilling diameter (inches)	Steel	1-9/16 ~ 31/32		31/32 ~ 3/4		3/4 ~ 15/32	
	Cast Iron	1-3/16 ~ 1-1/2		1-1/2 ~ 1-3/32		1-3/32 ~ 7/8	
Tapping (inches)		3/4 ~ 5/8		5/8 ~ 7/32		7/32 ~ 1/8	

		4 		5 		6 	
		LOW	HIGH	LOW	HIGH	LOW	HIGH
Speed (RPM)	60Hz	228	456	398	796	750	1500
	50Hz	190	381	332	665	626	1253
Suitable drilling diameter (inches)	Steel	3/4 ~ 15/32	15/32 ~ 3/8	3/8 ~ 7/32		7/32 ~ 1/8	
	Cast Iron	1-3/32 ~ 7/8	7/8 ~ 3/4	3/4 ~ 3/8		3/8 ~ 1/8	
Tapping (inches)		7/32 ~ 1/8	Not recommended				

Table 3

11.0 Troubleshooting the J-1230R

Trouble	Probable Cause	Suggested Remedy
Spindle overloads, causing relay to trip.	Drill bit is too large.	Turn off power, wait three minutes after spindle stops turning, then push the re-set on the relay in the control box.
	Feed rate too fast.	
	Operation not in compliance with speed and feed rate tables.	Correct initial problem by using shorter drill bit or lower feed rate; consult appropriate feed and speed rate tables.
	Fuse is burned out.	Replace fuse if needed. Verify proper voltage at power source.
	Low voltage.	
Spindle overloads, causing fuse to blow.	Drill bit is too large.	Replace fuse in control box.
	Feed rate too fast.	Correct initial problem by using smaller drill bit or lower feed rate; consult appropriate feed and speed rate tables.
	Operation not in compliance with speed and feed rate tables.	

Table 4

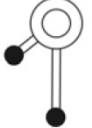
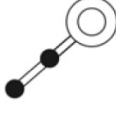
If drill bit gets broken in the spindle:

1. Move arm/spindle control lever to neutral.
2. Press emergency stop button.
3. Push the head/gearbox out of the way.
4. Pinch the end of the broken bit with pliers.
5. Rotate counterclockwise and pull it out upwards.

If screw tap gets broken in the spindle:

1. Move arm/spindle control lever to neutral.
2. Press emergency stop button.
3. Using a thread reaser, rotate the screw tap counterclockwise until it comes out.

If something becomes entangled during operation:

1. Press emergency stop button.
2. Disconnect power.
3. Switch speed change lever to highest gear.
4. Rotate spindle by hand in reverse direction from that used during the operation, until the obstruction is free.

12.0 Maintenance

Regularly scheduled maintenance is crucial to ensure a long service life for your machine. The schedule below shows general cleaning, lubrication points and coolant replacement information for the J-1230R Radial Arm Drill Press. Item numbers are located in figures 17-21. Using proper eye protection, clean parts using a metal brush and a rag dipped with oil (Mobil Vactra AA or equivalent). **Push stop button and power off before lubricating.** Follow local regulations for disposal of used coolant/lubricants.

12.1 General Cleaning

No.	Item	Action	Interval	Lubricant
1	Column	Clean and lightly wipe with oil	Daily	Mobil Vactra oil AA
2	Arm Rail	Clean and lightly wipe with oil	Daily	Mobil Vactra oil AA
3	Spindle	Clean and lightly wipe with oil	Daily	Mobil Vactra oil AA
4	Box Table	Clean and lightly wipe with oil	Daily	Mobil Vactra oil AA
5	Base	Remove shavings; clean and wipe with oil	Daily	Mobil Vactra oil AA
6	Ball Screw	Clean with metal brush and oiled rag	Weekly	Mobilux Grease No. 3
7	Counterweight guide rails	Clean and wipe with oil	Daily	Daily
8	Spindle motor	Blow dust from fan housing with compressed air	Periodically	--

Table 5

12.2 Lubrication

No.	Item	Location	Action	Interval	Lubricant *
9	Oil Cup (for arm/column contact)	Top and bottom of arm base at column	Add lubricant to full capacity	Daily	Mobil Vactra oil AA
10	Oil Cup (for spindle)	Top of drill head	Add lubricant to full capacity	Daily	Mobil Vactra oil AA
11	Oil Cups - 2 (for head/arm contact)	Right side of drill head	Add lubricant to full capacity	Daily	Mobil Vactra oil AA
12	Arm Raising Worm Gear	Rear of column	Top off at fill hole (12a). Fill to sight glass full level (12b).	Check sight glass daily	Mobil Vactra oil AA
			Replace annually; drain at (12c). Use sight glass to fill to capacity. Capacity = 2 liters (1/2 gal.)	Once per year	
13	Counterweight Chain	Behind drill head	Wipe with oiled rag	Weekly	Mobil Vactra oil AA
14	Coolant	Reservoir in base	Monitor for cleanliness and efficiency. Replace when dirty or when cutting becomes inefficient. Capacity = 30 liters (8 gal.)	Frequent inspection; top off as needed	Use high quality coolant of choice
15	Grease nipple (for spindle)	On spindle	Lubricate with lube gun	Daily	Mobilux Grease No. 3
16	Rack	On arm	Lubricate with lube gun	Every 3 days	Mobil Vactra oil AA
17	Oil Cups - 2 (for clamping)	Rear of column	Add lubricant to capacity	Daily	Mobil Vactra oil AA
18	Gearbox	Top and right side of drill head	Top off at fill hole (18a). Fill to sight glass full level (18b).	Check sight glass daily	Mobil Vactra oil AA
			Replace annually; drain at (18c). Use sight glass (18b) to fill to capacity. NOTE: Put pipe thread compound on drain plug before re-installing. Capacity: 4.5 Liters (1.2 gal.)	Once per year	

Table 6

* **IMPORTANT:** If switching brands of lubricants, prevent compatibility issues by thoroughly draining and, if possible, cleaning the reservoir before filling with the replacement brand.

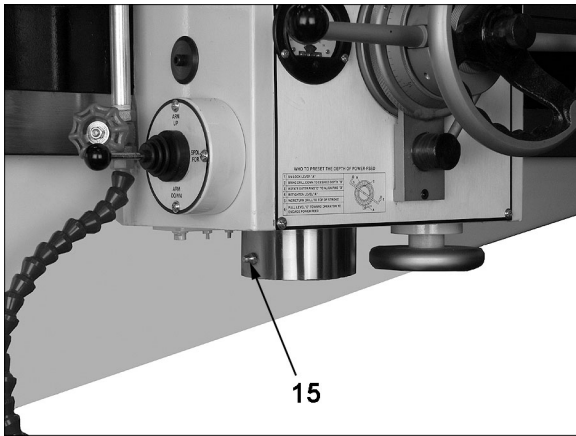

Figure 17

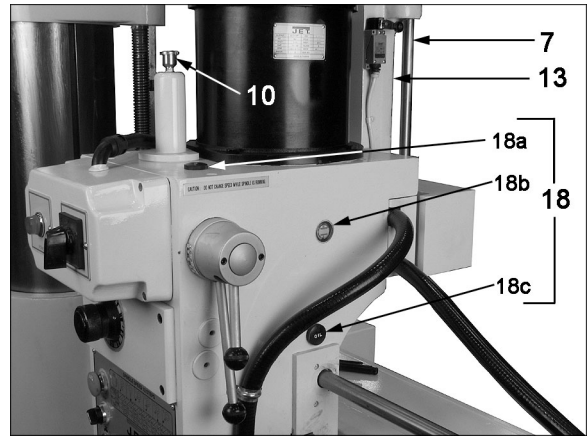

Figure 18

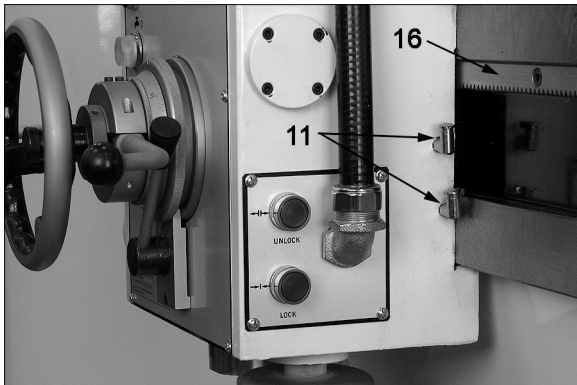

Figure 19

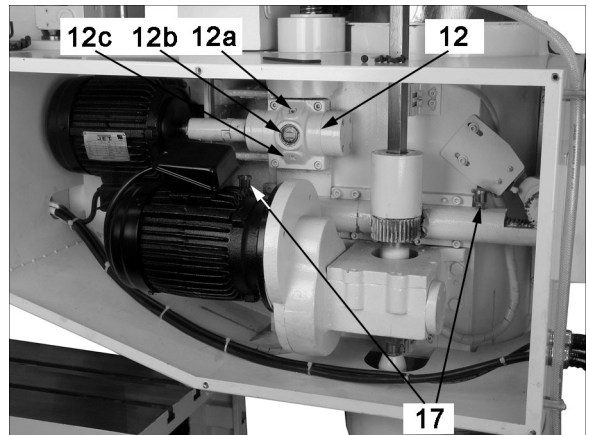

Figure 20

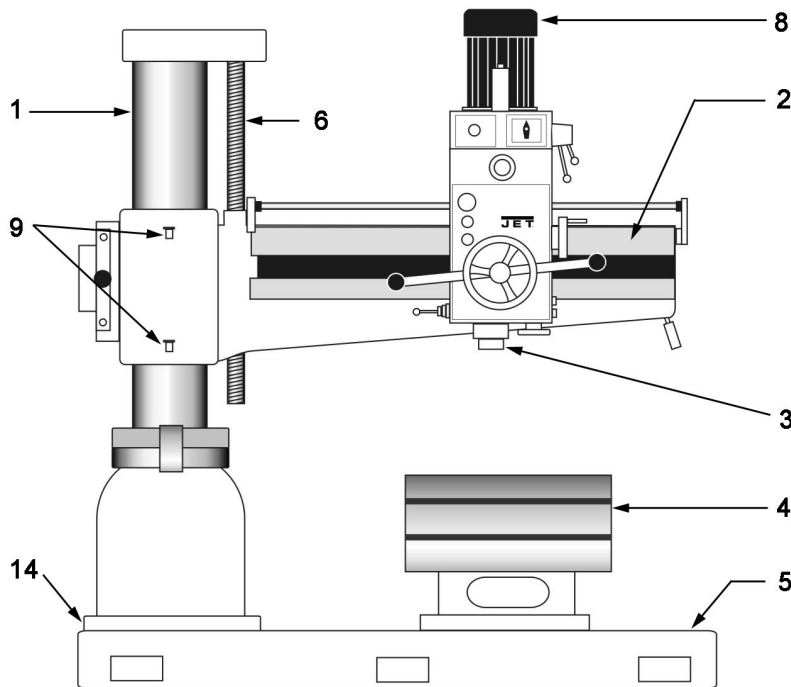
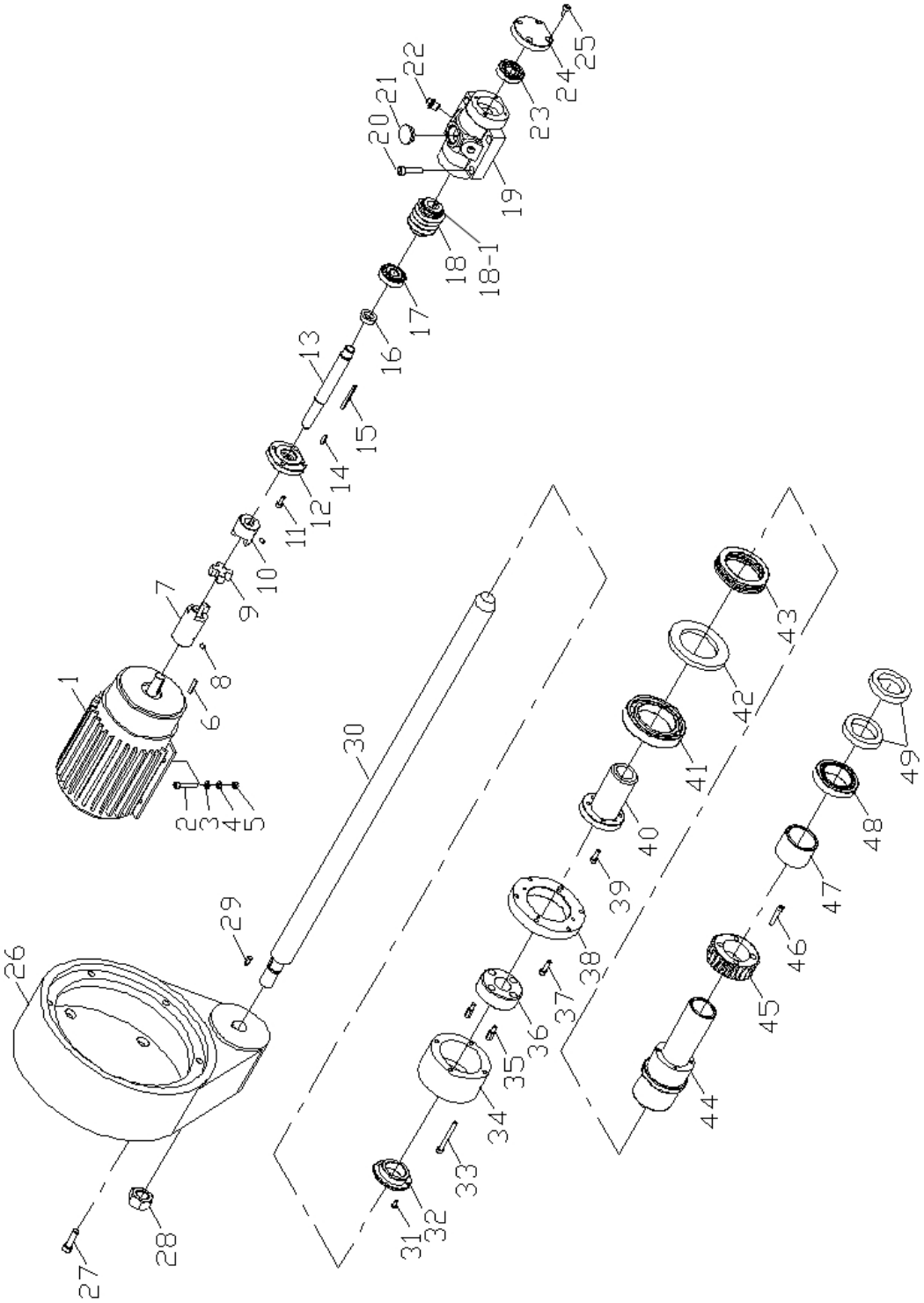

Figure 21

13.0 Replacement Parts

Replacement parts are listed on the following pages. To order parts or reach our service department, call 1-800-274-6848 Monday through Friday, 8:00 a.m. to 5:00 p.m. CST. Having the Model Number and Serial Number of your machine available when you call will allow us to serve you quickly and accurately.

13.1.1 Riser Mechanism: Exploded View



13.1.2 Riser Mechanism: Parts List

Index No.	Part No.	Description	Size	Qty
1	5232451	Motor (Elevating)	1HP, 230/460V	1
2	TS-1503091	Socket Head Cap Screw	M6 x 40L	4
3	TS-2361061	Spring Washer	M6	4
4	TS-1550041	Flat Washer	M6	4
5	TS-1540041	Hex Nut	M6	4
6	5232461	Key	6mm x 30L	1
7	5232481G	Adaptor		1
8	5232471	Set Screw	M6 x 8L	4
9	5232491	Plastic Joint		1
10	5232521G	Adaptor		1
11	5232531	Socket Head Cap Screw	M6 x 14L	4
12	5232541G	Cover		1
13	5232591	Worm Shaft		1
14	5232571	Key	5mm x 20L	1
15	5232581	Key	5mm x 55L	1
16	5232551	Oil Seal	TC17 x 28 x 7 mm	1
17	5232561	Bearing	30303	1
18	5232621	Worm		1
18-1	M1312-S36	Retainer	S36	1
19	5232641G	Worm Housing		1
20	TS-1504081	Socket Head Cap Screw	M8 x 40L	1
21	5232631	Oil Level Gauge		4
22	M0604006	Plug	PT1/4"	1
23	5232651	Bearing	30303	2
24	5232661G	Bearing Cover		1
25	5232671	Socket Head Cap Screw	M6x14L	1
26	J-5232681G	Top Cap		1
27	TS-1505051	Socket Head Cap Screw	M10 x 35L	1
28	5232691	Nut	M24	6
29	5232711	Key	6mm x 20L	1
30	5232721	Lead Screw		1
31	TS-1533042	Phillips Pan Head Machine Screw	M5 x 12L	1
32	10415	Compression Cover		2
33	M1401-M6x65	Socket Head Cap Screw	M6 x 65L	1
34	5232811G	Safety Device Cover		4
35	10177	Bolt		1
36	5232791	Safety Nut		2
37	TS-1503061	Socket Head Cap Screw	M6 x 25L	1
38	5232781G	Bearing Cover		6
39	TS-1503051	Socket Head Cap Screw	M6 x 20L	1
40	5232761	Brass Sleeve		4
41	5232751	Ball Bearing	6014ZZ	1
42	5232741	Collar		1
43	5232731	Bearing	51114	1
44	5232881	Up-Down Rolling Shaft		1
45	5232871	Worm Gear		1
46	TS-1503081	Socket Head Cap Screw	M6 x 35L	1
47	5232861	Collar		4
48	5232851	Bearing	32010	1
49	5232841	Oil Seal	TC50 x 72 x 12mm	1

13.2.1 Column and Base: Exploded View

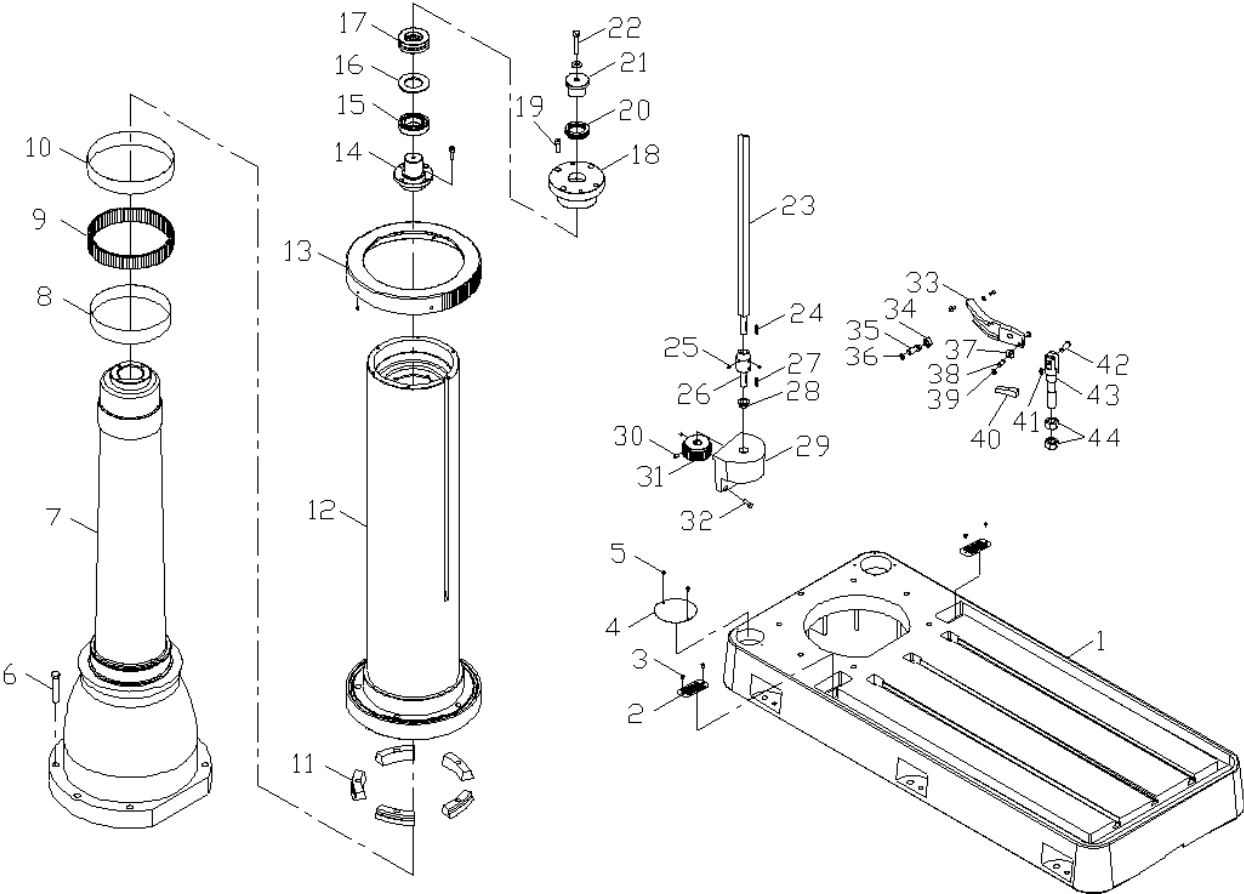

13.2.2 Column and Base: Parts List

Index No.	Part No.	Description	Size	Qty
1	J-5232911G	Base		1
2	10277G	Filter Screen		2
3	5513357	Phillips Pan Head Machine Screw	3/16" x 3/8"L	4
4	J-10037G	Cover		1
5	5513357	Phillips Pan Head Machine Screw	3/16" x 3/8"L	2
6	J-5232921	Bolt	M18 x 100L	7
7	5232941G	Internal Column		1
8-10	5232931	Needle Bearing		1
11	5233131	Wedge		5
12	5233041	External Column		1
13	J-5233281	Locking Cover		1
14	5233031	Top Bearing Cover		1
15	5233021	Bearing	6211	1
16	5233011	Washer		1
17	5232991	Thrust Bearing	3911	1
18	5232981	Fixed Bearing Cover		1
19	TS-1505051	Socket Head Cap Screw	M10 x 35L	4
20	5232971	Thrust Bearing	51111	1
21	5232961	Top Bearing Cover		1
22	5232951	Bolt	1/2"-12N x 3"L	1
23	5233271	Locking Shaft		1
24	5233251	Key	6mm x 30L	1
25	TS-1524021	Set Screw	M8 x 10L	2
26	5233211G	Shaft		1
27	5233141	Key	6mm x 30L	1
28	5233221	Bushing		1
29	J-5233231G	Locking Bracket		1
30	TS-1524021	Set Screw	M8 x 10L	2
31	5233261	Clamping Gear		1
32	TS-1504051	Socket Head Cap Screw	M8 x 25L	5
33	5233051	Slip Block		5
34	10241	Collar		5
35	5233071	Slip Bar		5
36	5233061	Retaining Ring		5
37	5233171	Roller		5
38	5233081	Fixing Shaft		5
39	5233091	Retaining Ring	E6	10
40	5233181	Slip Bracket		5
41	5233061	Retaining Ring	S10	5
42	5233071	Slip Bar		5
43	5233151	Elevating Shaft		5
44	5233111	Nut	5/8"-11UNC	10
	1230BT	Box Table (not shown)	635 x 520 x 419mm	1

13.3.1 Arm (Front): Exploded View

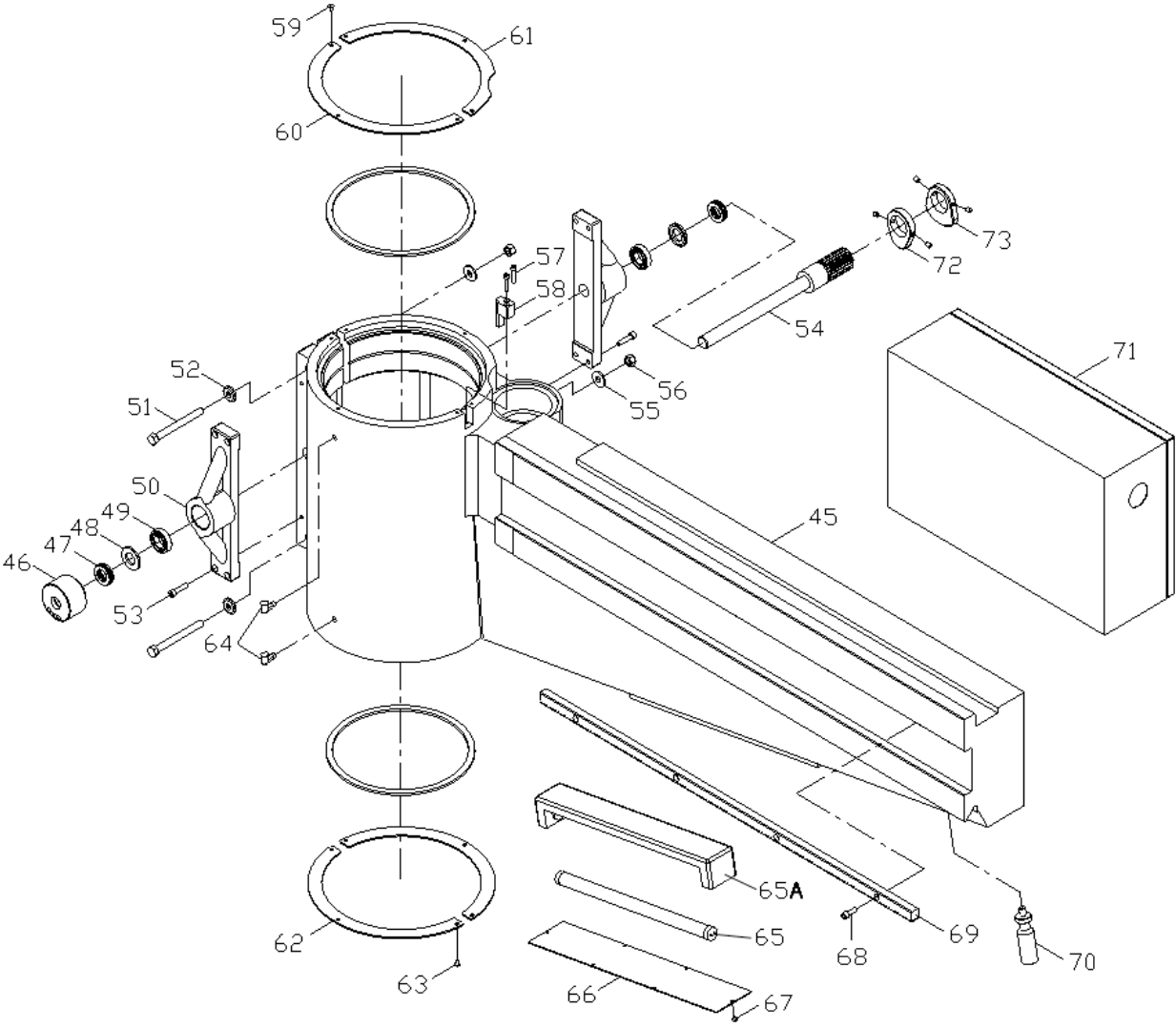

13.3.2 Arm (Front): Parts List

Index No.	Part No.	Description	Size	Qty
45	J-5233371G	Arm		1
46	5233431	Locking Nut		1
47	5233441	Thrust Bearing	51105	2
48	5233451	Plain Washer		2
49	5233461	Ball Bearing	6005ZZ	2
50	J-5233411G	Fixed Clamping Block		2
51	5233421	Bolt	1/2" x 5"L	2
52	10040	Washer		2
53	TS-1504071	Socket Head Cap Screw	M8 x 35L	8
54	5233381	Locking Shaft		1
55	J1230R-455	Washer		2
56	5235811	Hex Nut	1/2"	2
57	TS-1503071	Socket Head Cap Screw	M6 x 30L	2
58	10032	Key		1
59	M1425001	Pan Head Socket Screw	3/16" x 3/8"L	6
60	J1230R-460G	Upper Compression Cover		1
61	10798G	Upper Compression Cover (notched)		1
62	J1230R-462G	Lower Compression Cover		2
63	M1425001	Pan Head Socket Screw	3/16" x 3/8"L	6
64	5233391	Oil Cup	PT1/8" x 90°	2
65	5233331	Work Lamp	FS51441	1
65A	5233341	Lamp Seat		1
66	5233311	Acrylic Lamp Cover		1
67	5513357	Phillips Pan Head Machine Screw	3/16" x 3/8"L	12
68	TS-1504051	Socket Head Cap Screw	M8 x 25L	4
69	5233351	Arm Rack		1
70	10033	Handle		1
71	J-10393G	Electric Control Box (without components)		1
72	10259	Collar		1
73	10258	Collar		1
74	CL-HV	Triangular Caution Label-High Voltage (not shown)	...3"W x 2-1/2"H	1

13.4.2 Arm (Rear) and Clamping Gearbox: Parts List

Index No.	Part No.	Description	Size	Qty
1	J-5236011	Motor (Clamping)	1HP, 230/460V	1
2	5236031	Key	6mm x 30L	1
3	5236021	Motor Gear		1
4	J-5236071G	Upper Cover		1
5	TS-1504051	Socket Head Cap Screw	M8 x 25L	6
6	5236081	Bearing	32205	1
7	5236091	Gear		1
8	5236151	Worm Shaft		1
9	5236211	Key	7mm x 25L	1
10	J-5236141G	Gear Case		1
11	5236161	Bearing	32205	1
12	J-5236181G	Bearing Cover		1
13	TS-1503041	Socket Head Cap Screw	M6 x 16L	4
14	J-5236131G	Gear Case Cover		1
15	TS-1504051	Socket Head Cap Screw	M8 x 25L	5
16	5236431	Bearing	6009ZZ	1
17	5236411	Collar		1
19	TS-1503061	Socket Head Cap Screw	M6 x 25L	4
20	5236391	Worm Gear		1
21	5236381	Shaft		1
22	5236471	Key	6mm x 30L	2
23	5236371	Bearing	6009ZZ	1
24	5236351	Retainer	R75	1
25	5236331	Gear		1
26	TS-1524021	Set Screw	M8 x 10L	1
27	J-5236221G	Bushing		1
28	5236231	Cover		1
29	M1414006	Pan Head Socket Screw	3/16" x 3/8"L	3
30	5236261	Locking Shaft		1
31	5236271	Bushing		1
32	TS-1523031	Set Screw	M6 x 10L	2
33	5236291	Bushing		1
34	J-5236311G	Block		1
35	TS-1504061	Socket Head Cap Screw	M8 x 30L	4
36	J-5236321G	Arm		1
37	5236621	Arm Rack		1
38	5236591	Bolt	M8 x 30L	2
39	5236611	Rack Shaft		1
40	5236581G	Block		1
41	5236571G	Block		1
42	TS-1504051	Socket Head Cap Screw	M8 x 25L	12
43	TS-1504061	Socket Head Cap Screw	M8 x 30L	4
44	J-5236641G	Block		1
45	BB-6004ZZ	Ball Bearing	6004ZZ	1
46	5236841	Rubber Tap		1
47	5236651	Shaft		1
48	5236841	Rubber Tap		1
49	5236741	Bushing		1
50	5236771	Gear		1
51	5236751	Bushing		1
52	5236761	Retaining Ring	S15	1
53	5236721	Retaining Ring	S19	1
54	5236731	Bushing		1
55	5236681	Shaft		1
56	5236691	Key	5mm x 50L	1
57	5236781	Gear		1
58	TS-1523021	Set Screw	M6 x 8L	2
59	5236821	Gear		1
60	TS-1523021	Set Screw	M6 x 8L	1
61	5236671	Bushing		1

Index No.	Part No.	Description	Size	Qty
62	5236711	Retaining Ring	S19	1
63	10314WG	Gear Box Cover		1
64	5236781	Gear		1
65	5236441	Bushing		1
66	10315	Washer		1
67	5236531	Shaft		1
68	5236521	Key	5mm x 18L	1
69	5236541	Key	6mm x 30L	1
70	5236561	Gear		1
71	TS-1524021	Set Screw	M8 x 10L	1
72	5236491G	Block		1
73	TS-1505041	Socket Head Cap Screw	M10 x 30L	2
74	TS-1523021	Set Screw	M6 x 8L	1
75	J-10301G	Gear Box		1
77	J1230R-WL	Warning Label – Tipping Risk (not shown)	5-1/4"W x 8-1/4" H	1

13.5.1 Coolant System: Exploded View

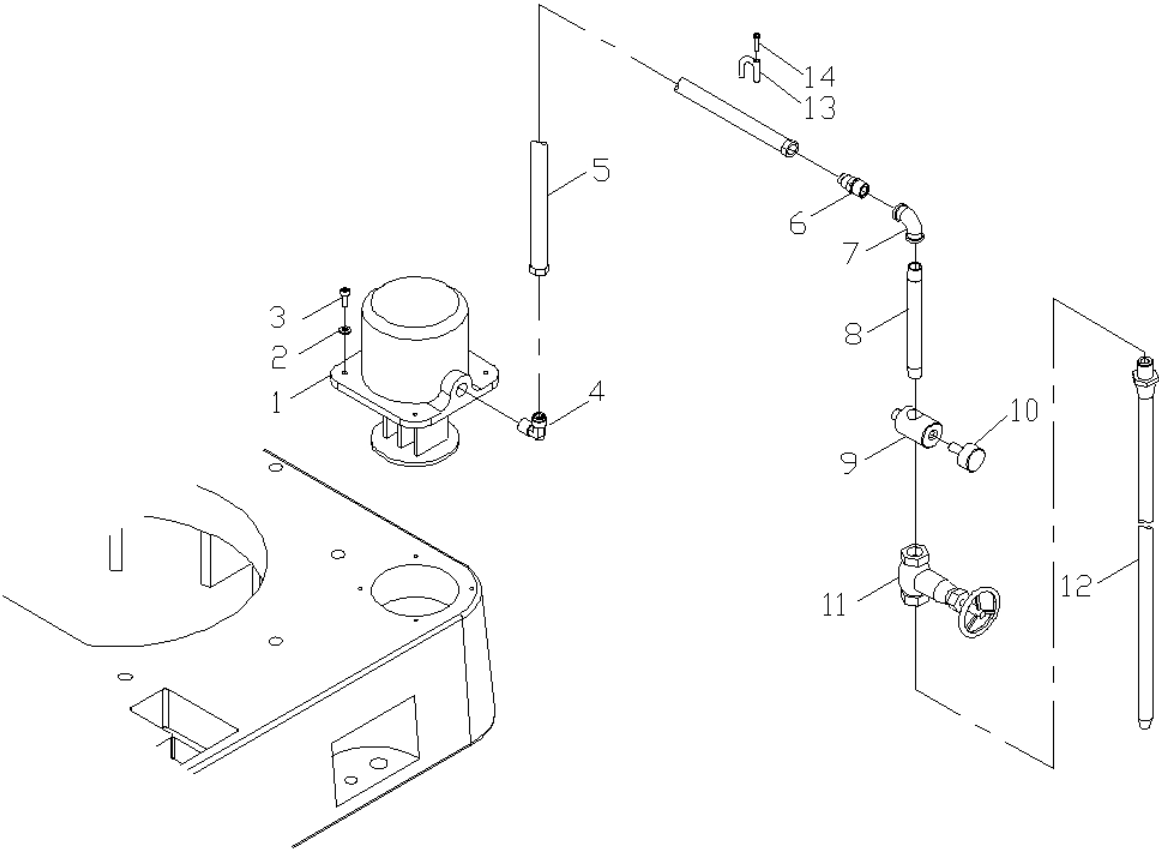

13.5.2 Coolant System: Parts List

Index No.	Part No.	Description	Size	Qty
1	J-5232291	Coolant Pump	1/8HP 130L 220/440V	1
2	TS-1550041	Flat Washer	M6	4
3	TS-1503041	Socket Head Cap Screw	M6 x 16L	4
4	5232321	90-Degree Elbow	PT1/4" x PS1/4" x 90°	1
5	5232271	Hose	PT3/8" x 130"L	1
6	5232411	Male Connector	PT3/8" x PS3/8"	1
7	5232341	90-Degree Elbow	3/8" x 90°	1
8	5232371	Tube	3/8" x 15"L	1
9	5232351	Tube Sleeve		2
10	5232391	Knurled Screw	M10 x 25L	2
11	5232421	Brass Valve	3/8"	1
12	5232431	Coolant Hose	3/8" x 450L	1
13	M1315017	Tube Holder	UC-5	2
14	5513357	Phillips Pan Head Machine Screw	3/16" x 3/8"L	2

13.6.1 Gearbox Assembly (Head): Exploded View

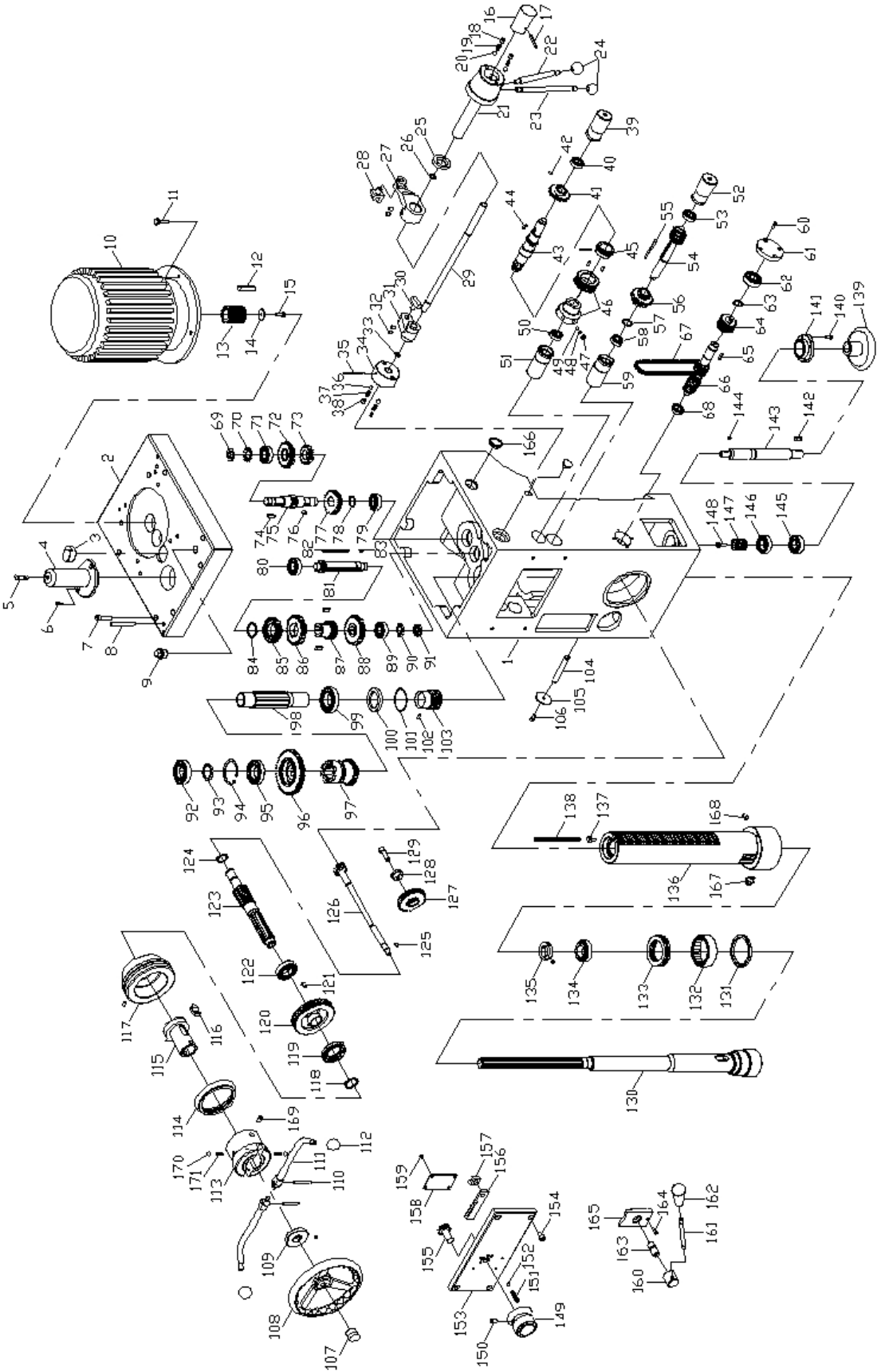

13.6.2 Gearbox Assembly (Head): Parts List

Index No.	Part No.	Description	Size	Qty
	J-5235431GA	Gearbox Assembly (includes #1 thru 171)		1
1	J-5235431G	Gearbox Housing		1
2	J-5234151G	Gearbox Cover		1
3	5234211	Gasket		1
4	J-5234161G	Spindle Cover		1
5	5234171	Oil Cup	PT1/8" x 3/4"	1
6	TS-1503031	Socket Head Cap Screw	M6 x 12L	2
7	M1401-M8x65	Socket Head Cap Screw	M8 x 65L	8
8	5234191	Taper Pin	#7 x 75L	2
9	M0604005	Oil Fill Plug	PT1/2"	2
10	J-5234431	Motor (Spindle)	3/5 HP, 230V	1
	J-5234431-460	Motor (Spindle)	5 HP, 460V	1
11	5234421	Bolt	M10 x 30L	4
12	5234411	Key	8mm x 40L	1
13	5234441	Motor Gear		1
14	5234451	Plain Washer		1
15	TS-1503051	Socket Head Cap Screw	M6 x 20L	1
16	5234631	Shaft Cover		1
17	M1305-5x40	Spring Pin	5mm x 40L	1
18	TS-1525011	Set Screw	M10 x 10L	2
19	10681	Spring		2
20	SB-5/16	Steel Ball	5/16"	2
21	5234651	Three Step Speed Change Lever Adaptor		1
22	5234861	Three Step Speed Change Lever (Short)		1
23	10324	Three Step Speed Change Lever (Long)		1
24	5234871	Plastic Knob	3/8"	2
25	5234661	Oil Seal	TC30 x 45 x 8mm	1
26	5234741	O-Ring	P12	1
27	5234671	Speed Change Rocker Arm		1
28	5234681	Copper Block		1
29	5234621	Spindle Change Shaft		1
30	5234711	Copper Block		1
31	5234721	Speed Change Rocker Arm		1
32	TS-1524021	Set Screw	M8 x 10L	4
33	5234741	O-Ring	P12	1
34	5234031	Feed Speed Selector		1
35	5234041	Spring Pin	5mm x 60L	1
36	SB-5/16	Steel Ball	5/16"	2
37	5234021	Spring		2
38	TS-1525011	Set Screw	M10 x 10L	2
39	5234941	Bushing		1
40	BB-6002ZZ	Ball Bearing	6002ZZ	1
41	5234921	Middle Gear		1
42	TS-1523021	Set Screw	M6 x 8L	1
43	5234891	Lower Feed Gear Shaft		1
44	5234881	Key	5mm x 12L	1
45	5234851	Gear		1
	J-5234831WGSA	Worm Gear with Sleeve Assembly (includes #46 thru 49)		1
46	J-5234831	Worm Gear with Sleeve		1
47	5235021	Set Screw	M10 x 6L	6
48	5234781	Spring		6
49	SB-5/16	Steel Ball	5/16"	6
50	5233971	Bearing	6002ZZ	1
51	5233981	Bushing		1
52	5234971	Bushing		1
53	BB-6002ZZ	Ball Bearing	6002ZZ	1
54	5235011	Lower Feed Gear Shaft		1
55	5234991	Key	5mm x 65L	1
56	5234771	Gear		1
57	5235031	Retaining Ring	S22	1

Index No.	Part No.	Description	Size	Qty
58	5233941	Ball Bearing	6002ZZ	1
59	5233951	Bushing		1
60	TS-1502031	Socket Head Cap Screw	M5 x 12L	4
61	J-5235061	Bearing Cover		1
62	BB-6204ZZ	Ball Bearing	6204ZZ	1
63	5235031	Retaining Ring	S22	1
64	5235081	Helical Tooth Gear		1
65	5235351	Key	5mm x 20L	1
66	5235111	Sprocket Shaft		1
67	5235091	Chain	25H x 86	1
68	BB-6002ZZ	Ball Bearing	6002ZZ	1
69	5234481	Lock Nut		1
70	5234491	Crown Washer	AW04	1
71	BB-6004ZZ	Ball Bearing	6004ZZ	1
72	5234521	Gear		1
73	5234531	Gear		1
74	5234551	Key	7mm x 20L	1
75	5234561	Gear Shaft		1
76	5234571	Key	7mm x 12L	1
77	5234581	Gear		1
78	5234591	Retaining Ring	S22	1
79	BB-6004ZZ	Ball Bearing	6004ZZ	1
80	BB-6004ZZ	Ball Bearing	6004ZZ	1
81	5234361	Gear Shaft		1
82	5234371	Key	6mm x 85L	2
83	5234351	Key	6mm x 10L	2
84	5234341	Retaining Ring	S35	1
85	5234331	Gear		1
86	5234321	Gear		1
87	5234311	Gear		1
88	5234281	Gear		1
89	BB-6004ZZ	Ball Bearing	6004ZZ	1
90	5234261	Crown Washer	AW04	1
91	5234251	Lock Nut		1
92	5234141	Ball Bearing	6007UU	1
93	5234131	Washer		1
94	M1312-R62	Retaining Ring	R62	1
95	5234121	Ball Bearing	6007UU	1
96	5234111	Clutch Upper Gear		1
97	5234091	Clutch Lower Gear		1
98	5234231	Spindle Shaft		1
99	5234241	Bearing	6007UU	1
100	5234071	Oil Seal	TC42 x 58 x 8	1
101	5234081	O-Ring	P30	1
102	TS-1523031	Set Screw	M6 x 6L	1
103	5234061	Worm		1
104	10353	Copper Key		1
105	10123	Washer		1
106	TS-1503031	Socket Head Cap Screw	M6 x 12L	1
107	5233551	Hand Wheel Lock Nut		1
108	5233561	Hand Wheel		1
109	10103	Nut		1
110	5233591	Spring Pin	5mm x 50L	2
111	5233581	Feed Handle		2
112	5233571	Plastic Knob	3/8"	2
113	5233611	Clutch Housing		1
114	5233651	Dial		1
115	5233691	Clutch Upper Gear		1
116	5233681	Key		1
117	5233661	Dial Seat		1
118	5233751	Retaining Ring	S30	1
119	5233761	Clutch		1

Index No.	Part No.	Description	Size	Qty
120	5233771	Worm Gear		1
121	5233731	Bolt	M6 x 14L	4
122	BB-6006ZZ	Ball Bearing	6006ZZ	1
123	5233781	Gear Shaft		1
124	5233791	Retaining Ring	S24	1
125	5233811	Key	5mm x 12L	1
126	5233741	Pinion Shaft		1
127	10215	Gear		1
128	10108	Eccentric Bushing		1
129	TS-1505041	Socket Head Cap Screw	M10 x 30L	1
130	5235151	Spindle		1
131	5235131	Lock Nut		1
132	5235191	Needle Bearing	RNA4911	1
133	BB-51111	Thrust Bearing	51111	1
134	BB-32006	Taper Bearing	32006	1
135	J-10190	Lock Nut		1
136	5235181	Quill		1
137	10352	Special Bolt		1
138	M1204006	Chain	25H x 86	1
139	5235421	Manual Feed Hand Wheel		1
140	TS-1502031	Socket Head Cap Screw	M5 x 12L	4
141	5235261	Bearing Housing		1
142	5235311	Key	6mm x 20L	1
143	5235321	Pinion Shaft		1
144	5235121	Key	4mm x 12L	1
145	BB-6204ZZ	Ball Bearing	6204ZZ	1
146	BB-6005ZZ	Ball Bearing	6005ZZ	1
147	5235331	Helical Tooth Gear		1
148	TS-1503051	Socket Head Cap Screw	M6 x 20L	1
149	5233871	Feed Speed Selector		1
150	5233841	Bolt	M10 x 16L	1
151	5233851	Spring		1
152	SB-5/16	Steel Ball	5/16"	1
153	J-5233891G	Gear Box Front Plate		1
154	TS-1504031	Socket Head Cap Screw	M8 x 16L	4
155	5233911	Feed Speed Change Gear		1
156	5233821	Feed Speed Change Rack		1
157	5233831	Copper Block		1
158	5233921	Plate		1
159	5233931	Bolt	3/16" x 1/4"L	1
160	10111	Nut		1
161	10072	Lock Lever		1
162	M1317005	Plastic Knob	5/16"	1
163	10110	Lock Screw		1
164	TS-1502041	Socket Head Cap Screw	M5 x 16L	1
165	10109	Set Block		1
166	5234751	Oil Level Gauge		1
167	5235271	Grease Nipple	PT1/8"	1
168	TS-1523021	Set Screw	M6x8L	1
169	5233641	Pin		1
170	SB-3/8	Steel Ball	3/8"	2
171	5233711	Spring		2

13.7.1 Rear of Head: Exploded View

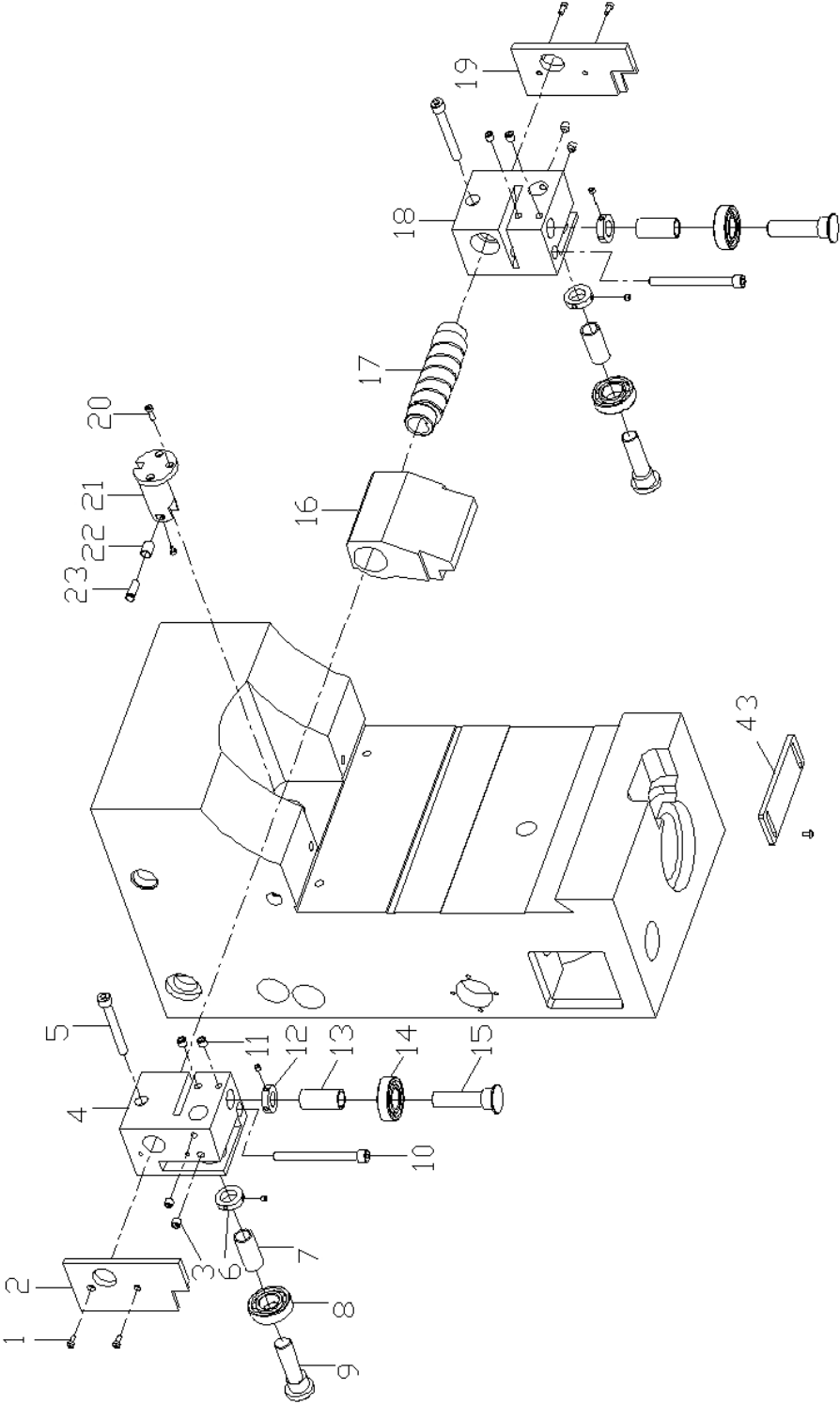

13.7.2 Rear of Head: Parts List

Index No.	Part No.	Description	Size	Qty
1	5235731	Bolt	3/16" x 1/2"L	4
2	J-5235721G	Aluminum Plate		1
3	TS-1525011	Set Screw	M10 x 10L	4
4	J-5235471G	Bearing Bracket		1
5	5235441	Socket Head Cap Screw	M10 x 85L	2
6	5235451	Adjustable Collar		2
7	5235691	Bushing		2
8	BB-6205ZZ	Bearing	6205ZZ	2
9	5235711	Eccentric Shaft		2
10	5235651	Bolt	M10 x 110L	2
11	TS-1525011	Set Screw	M10 x 10L	4
12	5235461	Adjustable Collar		2
13	5235671	Bushing		2
14	BB-6205ZZ	Bearing	6205ZZ	2
15	5235641	Eccentric Shaft		2
16	J-5235491G	Cam Shaft Sleeve		1
17	5235481	Cam Shaft		1
18	J-5235511G	Bearing Bracket		1
19	J-5235561G	Aluminum Plate		1
20	TS-1502041	Socket Head Cap Screw	M5 x 16L	3
21	5235421G	Eccentric Shaft		1
22	M0924-IRT1015-1	Bearing Inner Ring	IRT1015-1	1
23	10221	Shaft		1
43	10356G	Mounting Plate		1

13.8.1 Counterweight Assembly: Exploded View

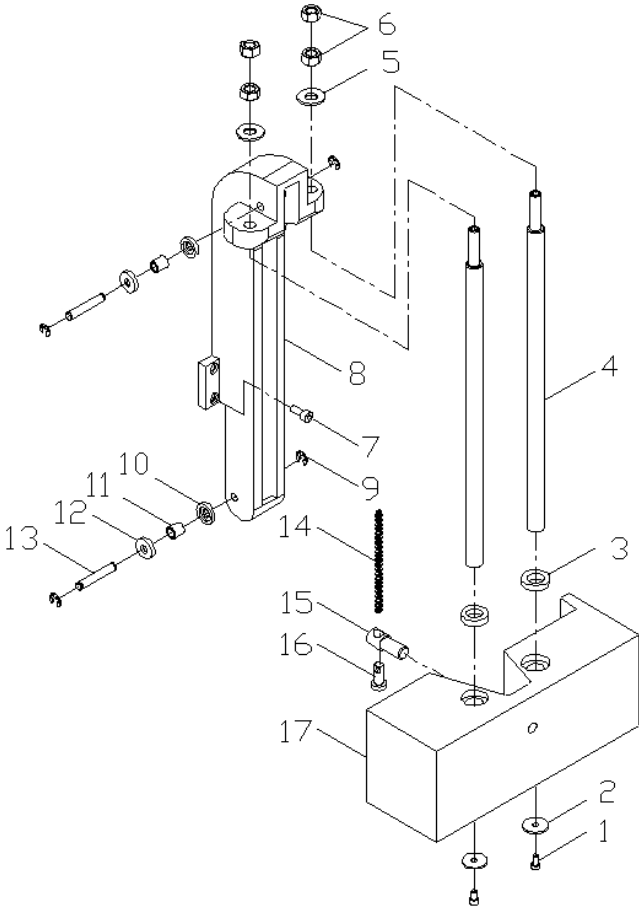

13.8.2 Counterweight Assembly: Parts List

Index No.	Part No.	Description	Size	Qty
1	TS-1503031	Socket Head Cap Screw	M6 x 12L	2
2	5235761	Washer		2
3	5235771	Oil Seal	TC19 x 32 x 8	2
4	5235781	Round Bar		2
5	5235791	Washer	1/2"	2
6	5235811	Nut	1/2"	4
7	5235831	Socket Head Cap Screw	M8 x 120L	4
8	J-5235841G	Chain Frame		1
9	5235911	Retainer	E9	4
10	10376	Collar		2
11	5235931	Bearing	TA1015Z	2
12	10376	Collar		2
13	5235941	Shaft		2
14	5235961	Chain	3/8" x 130	1
15	5235971	Bolt		1
16	5235981	Chain Adapter		1
17	J-5235991G	Cast Iron Block		1

14.0 Electrical Connections for J-1230R

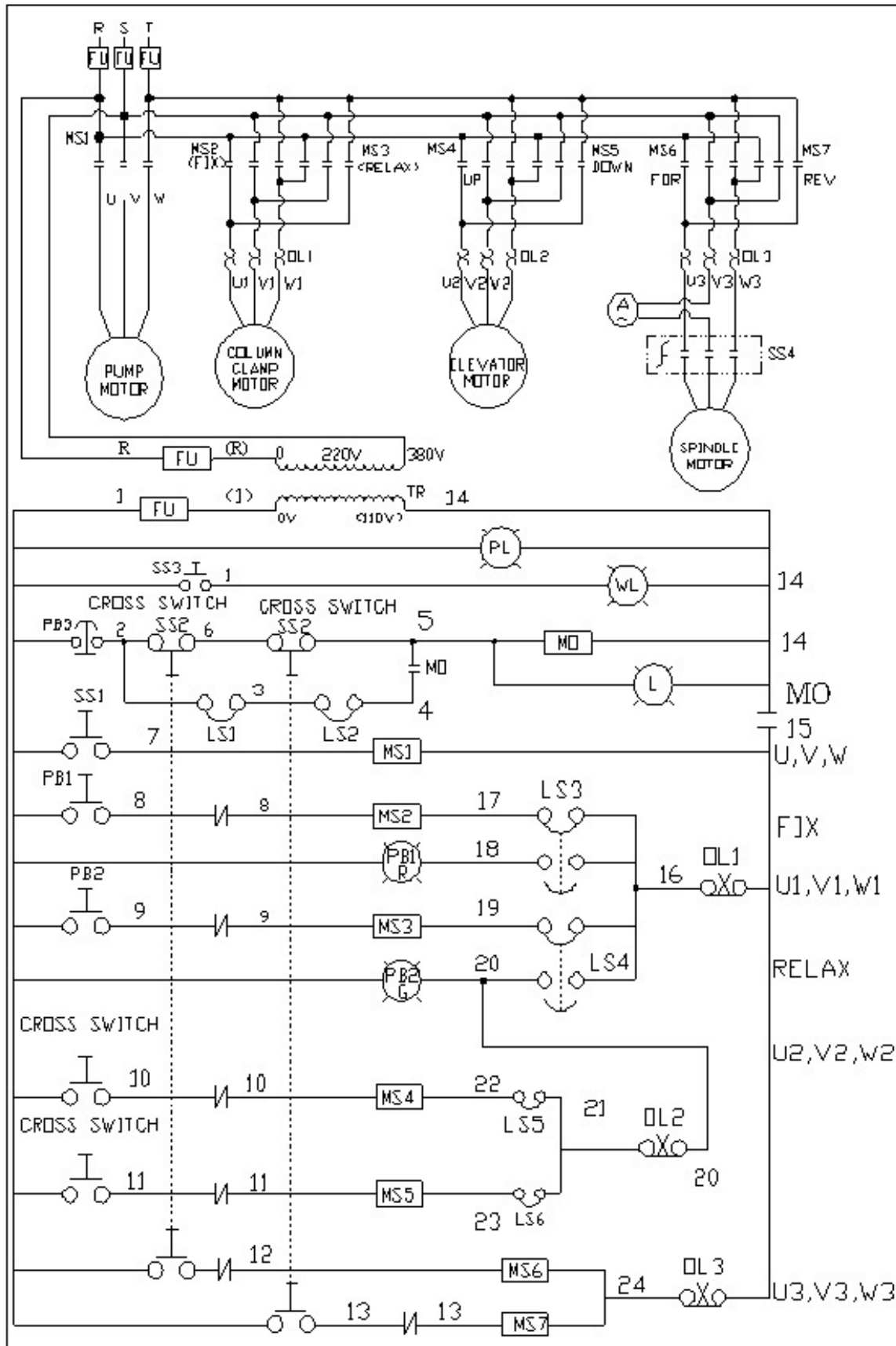

14.1 Electrical Connections for J-1230R: Parts List

Part No.	Symbol	Description	Size	Qty
E0701020	MS1	Magnetic Contactor	CU11,3a1b,110V	1
E0701020	MS2	Magnetic Contactor	CU11,3a1b,110V	1
E0701020	MS3	Magnetic Contactor	CU11,3a1b,110V	1
E0701020	MS4	Magnetic Contactor	CU11,3a1b,110V	1
E0701020	MS5	Magnetic Contactor	CU11,3a1b,110V	1
E0701021	MS6	Magnetic Contactor	CU18,110V	1
E0701021	MS7	Magnetic Contactor	CU18,110V	1
E0701020	MO	Magnetic Contactor	CU11,3a1b,110V	1
E2802003	Fu	Fuse Seat	3P(14*51)	1
E2802013	Fu	Fuse Seat	1P(14*51)	1
E3101012	Fu	Fuse	40A(14*51)	3
E3101016	Fu	Fuse	5A(14*51)	2
E1801047	TR	Transformer	PT40 100VA	1
E1602001		Safety Switch	XF163B	1
E1303001	SS1	Coolant Switch	ST-302	1
5231981	SS2	Cross Switch (includes 5231951)	Up 1A Down 1A	1
E1604001	SS3	Selector Switch	SN1021	1
E1603001	SS4	Pole Reversing Switch (Speed Change)	A441,CA10	1
E1701002	WL	Work Lamp	FS 51441	1
E1202011	PB1	Push Button	YK ϕ 22, 110V 1a1b (R)	1
E1202003	PB2	Push Button	YK ϕ 22, 110V 1a1b (G)	1
E1203002	PB3	Emergency Push Button	SBT-307	1
E2303006	L	Control Light	SP301 110V (White)	1
E2303007	PL	Power Light	SP301 110V (Red)	1
E0207002	OL1	Overload Relay (for 230V)	RHN 10/3.5-4.8A	1
E0207002	OL2	Overload Relay (for 230V)	RHN 10/3.5-4.8A	1
E0207040	OL3	Overload Relay (for 230V)	RHN 10/17-24A	1
E0207018	OL1	Overload Relay (for 460V)	RHN 10/1.8-2.5A	1
E0207018	OL2	Overload Relay (for 460V)	RHN 10/1.8-2.5A	1
E0207035	OL3	Overload Relay (for 460V)	RHN 10/8.5-12.5A	1
E0901006	LS1	Micro Switch	MJ2-1308R	1
E0901008	LS2	Micro Switch	TZ-8104	1
E0901007	LS3	Micro Switch	MJ2-1704	1
E0901007	LS4	Micro Switch	MJ2-1704	1
E0901007	LS5	Micro Switch	MJ2-1704	1
E0901007	LS6	Micro Switch	MJ2-1704	1
E3602001	A	Ammeter	SO65,30A	1
*		Coolant Pump	1/8HP, 2P, 3PH, L:130mm	1
*		Column Clamping Motor	1HP, 3PH, 4P	1
*		Elevating Motor	1HP, 3PH, 4P	1
*		Main (Spindle) Motor	5HP/3HP, 4P/8P	1

* see relevant breakdowns for stock numbers

This page intentionally left blank.



427 New Sanford Road
LaVergne, Tennessee 37086
Phone: 800-274-6848
www.jettools.com