



SHIFTING THE LIMITS



Fronius Datamanager

EN-US

Operating Instructions

System monitoring



Dear reader,

Introduction

Thank you for the trust you have placed in our company and congratulations on buying this high-quality Fronius product. These instructions will help you familiarize yourself with the product. Reading the instructions carefully will enable you to learn about the many different features it has to offer. This will allow you to make full use of its advantages.

Please also note the safety rules to ensure greater safety when using the product. Careful handling of the product will repay you with years of safe and reliable operation. These are essential prerequisites for excellent results.

Contents

General Information	7
General	9
General	9
Available Versions of Fronius Datamanager.....	9
Applicable DATCOM Components	9
Prerequisites for Operation	9
Required Inverter Software	10
Notes regarding radio certification	10
Scope of Supply.....	11
Configuration Examples.....	11
Calculating the data volume.....	13
General	13
Firmware versions for calculating the data volume.....	13
Calculating Data Volumes.....	13
Calculation examples.....	14
General information for the network administrator.....	16
Requirements.....	16
General firewall settings.....	16
Sending service messages via a DSL Internet connection.....	16
Using Fronius Solar.web and sending service messages	17
Controls, connections and indicators	18
Safety.....	18
Controls, Connections and Indicators	18
Schematic Connection of I/Os	20
Cabling.....	21
Fronius Solar Net clients.....	21
Fronius Solar Net Client Cabling.....	21
Requirements for the Solar Net Data Cables.....	21
Preassembled data cables.....	22
Installing Fronius Datamanager	23
Installing Fronius Datamanager – LAN overview.....	25
Safety.....	25
Installing Fronius Datamanager – LAN Overview	25
Installing Fronius Datamanager – WiFi overview.....	27
Safety.....	27
Installing Fronius Datamanager – WiFi Overview.....	25
Network settings for PC/laptop	29
General	29
Network settings for PC/laptop	29
Internet options for PC/laptop	31
Inserting Fronius Datamanager into an inverter.....	33
General	33
Safety.....	33
Fronius Datamanager plug-in positions	34
Installing and connecting WLAN antennas	35
General.....	35
Fronius IG, Fronius IG Plus, Fronius IG Plus V, Fronius CL: Installing and connecting antennas	35
Fronius IG USA, Fronius IG Plus USA, Fronius IG Plus V USA: Installing and Connecting Antennas	37
Installing Fronius Datamanager in Fronius Solar Net	39
Installing Inverters with Fronius Datamanager in Fronius Solar Net.....	39
Starting for the First Time – Opening the Fronius Datamanager Web Interface.....	40
Starting for the First Time – Opening the Fronius Datamanager Web Interface.....	40
Fronius Datamanager Web Interface – Overview.....	41
The Settings Menu.....	42
Other settings options	43
Starting up Fronius Datamanager – LAN.....	44

Starting Up Fronius Datamanager – LAN	44
Starting up Fronius Datamanager – WiFi.....	45
Starting Up Fronius Datamanager – WiFi	45
Connect to Fronius Datamanager	47
Connecting to Fronius Datamanager via internet browser.....	49
General	49
Requirements.....	49
Connecting to Fronius Datamanager via Internet Browser	49
For the network administrator	50
Connecting to Fronius Datamanager via Fronius Solar.access	51
General	51
Requirements	51
Connecting to Fronius Datamanager via Fronius Solar.access	51
For the network administrator	52
Connecting to Fronius Datamanager via the Internet and Fronius Solar.web	53
General	53
Function overview	53
Requirements	53
Accessing data from Fronius Datamanager via the Internet and Fronius Solar.web.....	54
For the network administrator	54
Current Data in Fronius Datamanager	55
Current Data in Fronius Datamanager.....	57
Current Comparison View.....	57
System Overview	58
Inverter/Sensor View.....	59
Fronius Datamanager Services	61
Services – System Information	63
System Information	63
Services – Network Diagnostics	64
Network Diagnostics	64
Services – Firmware Update.....	65
General	65
Automatic Update Search	65
Manual update search	66
Firmware update via web.....	67
Firmware update via LAN	68
Fronius Datamanager Settings	69
Settings – Passwords	71
General	71
Passwords	71
User password	71
Administrator Password	72
Forgot Your Password?	72
Settings – Time/Date	73
Time/Date General.....	73
Time/Date	73
Settings – General	75
General	75
Settings – Inverter.....	76
Views – Inverter	76
Settings – Sensor Cards	77
Sensor Cards	77
Settings – Logging	78
General	78
Logging	78
Memory capacity.....	78

Calculating memory capacity	78
Calculation example.....	79
Overwriting data when memory is full	79
"Delete Data" button	79
Settings – Internet Connection.....	80
General	80
Internet settings	80
Settings – LAN	81
General	81
LAN	81
Settings – WiFi.....	82
General	82
WiFi.....	82
Settings – WiFi Management.....	83
Setting Up Fronius Datamanager for WiFi Connection.....	83
Settings – Solar.web	85
General	85
Solar.web	85
Daily data transmission to Solar.web.....	85
Hourly data transmission to Solar.web	85
Settings – Service Messages.....	86
General	86
Service Messages.....	86
Settings – Energy Manager	88
General	88
Energy Manager	88
Settings – UC Editor	89
General	89
UC Editor	89
Connection Example.....	90
Appendix	93
Technical data.....	95
Technical Data	95

General Information

General

General

Fronius Datamanager is a network-compatible datalogger which combines the functionality of the Fronius Com Card and Fronius Datalogger Web on a plug-in card.

The Fronius Datamanager web interface provides a quick overview of the photovoltaic system.

The web interface can be accessed via a direct connection from the Intranet or, if properly configured, via the Internet.

Fronius Datamanager is equipped with an easy-to-configure system monitoring feature with an automatic alarm. The alarm can be signaled via SMS, e-mail, or fax.

When connected to Fronius Solar.access, real-time photovoltaic system data as well as archived data can be saved to a PC and analyzed. You can also make settings to all devices in Fronius Solar Net.

When connected to Fronius Solar.web, the real-time and archived data of a photovoltaic system can be easily accessed via the Internet or the Fronius Solar.web App. No difficult configuration is required. Data is sent automatically from Fronius Datamanager to Fronius Solar.web.

Available Versions of Fronius Datamanager

The following versions of Fronius Datamanager are available for the Fronius IG, Fronius IG Plus and Fronius CL inverters:

- with Fronius Com Card function
- with Fronius Com Card function and with WiFi

Various different antenna installation sets are available with the WiFi versions, depending on the inverter.

With the exception of the Fronius IG-TL and Fronius Agilo inverters, existing inverters can be upgraded with Fronius Datamanager.

Applicable DAT-COM Components

The Fronius Datamanager plug-in card installed in the inverter can be operated with the following DATCOM components:

- up to 100 x Fronius inverters
(incl. the inverter in which the Fronius Datamanager is installed)
 - up to 10 x Fronius Sensor Card or Fronius Sensor Box
 - up to 10 x Fronius Public Display Card or Fronius Public Display Box
 - up to 1 x Fronius Interface Card or Fronius Interface Box
 - up to 200 x Fronius String Control
-

Prerequisites for Operation

In order to ensure flawless data exchange online, it is essential to use an appropriate internet connection:

- For cabled internet solutions, Fronius recommends a download speed of at least 512 KB/s and an upload speed of at least 256 KB/s.
- For solutions with mobile internet services, Fronius recommends a standard transmission of at least 3 G with reliable signal strength.

These specifications do not provide an absolute guarantee of flawless operation. High error rates in the transmission, fluctuating receptions or misfires can have an adverse effect on Fronius Datamanager's online operation. Fronius recommends on-site testing to ensure that the connections meet the minimum requirements.

Since Fronius Datamanager acts as a data logger, no other data logger may be present in the Fronius Solar Net ring. Only have one Fronius Datamanager for each Fronius Solar Net ring.

The following DATCOM components may not be operated together with the Fronius Datamanager in a Fronius Solar Net ring:

- Fronius Com Card
- Fronius Power Control Card/Box
- Fronius Modbus Card
- Fronius Datalogger Web
- Fronius Personal Display DL Box
- Fronius Datalogger easy/pro

The plug-in card must be installed in an inverter in order for Fronius Datamanager to operate.

Required Inverter Software

The following inverter software versions must be used in order to correctly display the daily energy with Fronius Datamanager:

Inverter	required software version according to display (MainControl)
Fronius IG 15 - 60	V2.9.4 or higher
Fronius IG 2000 - 5100	starting from series no. 19153444
Fronius IG 300 - 500	V3.6.4.0 or higher
Fronius IG Plus 35 - 150	V4.22.00 or higher

The relevant inverter software version can be downloaded for free from our homepage (<http://www.fronius.com>).

If you have any questions, please contact pv-support@fronius.com.

Notes regarding radio certification

Fronius Datamanager plug-in cards with WLAN are equipped with a wireless module.

Wireless modules in the USA require FCC certification:



This device complies with Part 15 of the FCC Rules. Operation is subject to the following conditions:

- (1) The device may not cause harmful interference
- (2) The device must accept any interference received, including interference that may cause undesired operation.

This device meets the FCC exposure limits for an uncontrolled environment. The internal/external antenna used for this module must be kept at a distance of at least 20 cm from all persons and may not be fitted or operated near other antennas or transmitters.

FCC ID: PV7-WIBEAR-SF-STA

Unless otherwise expressly permitted by the manufacturer, changes or modifications to the wireless module are not allowed and lead to a loss of the right of use to the device by the user.

Scope of Supply

Basic equipment:

- 1 x Fronius Datamanager plug-in card
- 1 x Ethernet cable 5 m, blue
- 1 x Terminating plugs
- 1 x 12-pin plug

Additional equipment, depending on the inverter and WLAN antenna installation set:

- 1 x antenna	Fronius IG
- 1 x 1 m RG58 antenna cable	Fronius IG Plus
- 1 x mounting bracket	Fronius IG Plus V
- 1 x Double-sided adhesive tape	
- 1 x antenna	Fronius IG 300 - 500
- 1 x 3 m RG58 antenna cable	Fronius CL
- 1 x mounting bracket	Fronius CL - USA
- 1 x Double-sided adhesive tape	
- 1 x antenna	Fronius IG 2000 - 5100 - USA
- 1 x 0.4 m RG58 antenna cable	Fronius IG Plus - USA
- 1 x 3/4 in. Screw joint	Fronius IG Plus V - USA
- 1 x 3/4 in. Hex nut	
- 1 x 3/4 in. Seal	

Configuration Examples

Linking inverters with Fronius Datamanager to a PC:

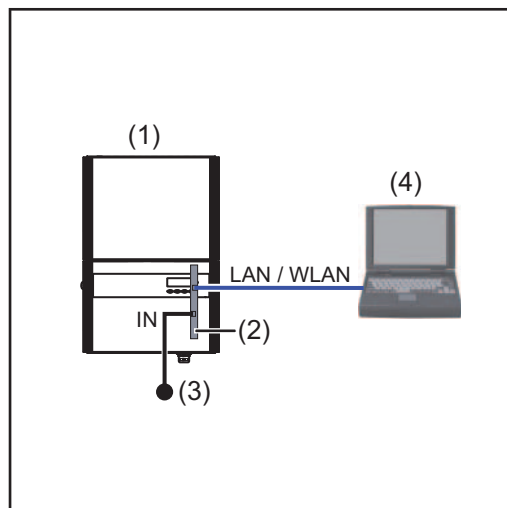

- (1) Inverter
- +
- (2) Fronius Datamanager
- (3) Terminating plug
- (4) PC/Laptop



NOTE! When linking an inverter with Fronius Datamanager to a PC it is necessary to insert a terminating plug into the Fronius Datamanager IN connection socket.

Linking inverters with Fronius Datamanager to other inverters, a Fronius Sensor Box, and a PC:

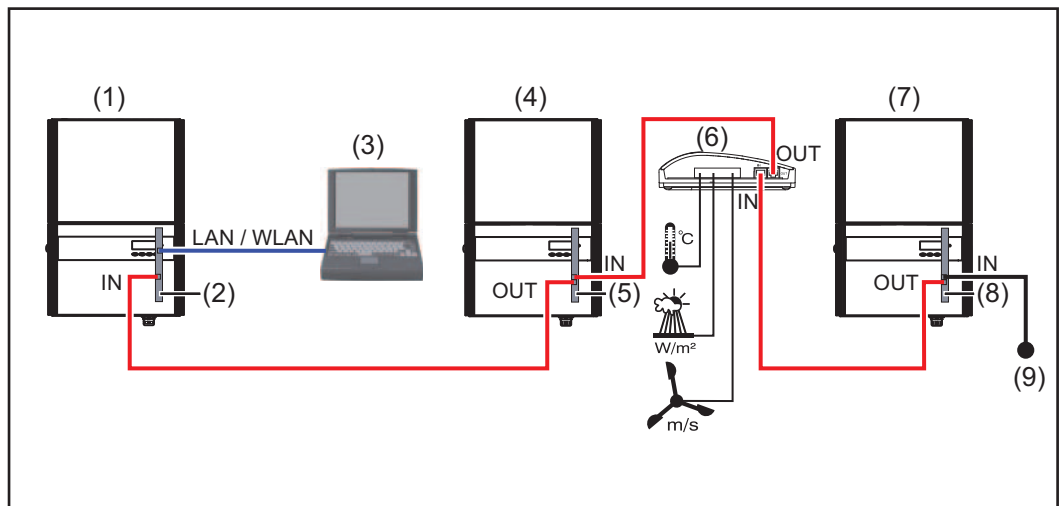

- | | | | |
|-----|---------------------|-----|--------------------|
| (1) | Inverter | (6) | Fronius Sensor Box |
| | + | (7) | Inverter |
| (2) | Fronius Datamanager | | + |
| (3) | PC/Laptop | (8) | Fronius Com Card |
| (4) | Inverter | (9) | Terminating plug |
| | + | | |
| (5) | Fronius Com Card | | |



NOTE! When linking several DATCOM components in a Fronius Datamanager network:

Use the data cable to connect the IN connection socket of Fronius Datamanager with the OUT connection socket of the next DATCOM component. A terminating plug must be inserted into the empty IN connection socket of the last DATCOM component.

The inverter with the Fronius Datamanager must always be connected either at the start or at the end of the data chain.

Calculating the data volume

General

When operating the Fronius Datamanager, data is generated and needs to be transmitted online.

In order to select a suitable internet connection it is necessary to calculate the data volume.

The following data volume calculation provides an overview of the amount of data generated when operating Fronius Datamanager.

Firmware versions for calculating the data volume

The data volume calculation is based on Fronius Datamanager Firmware versions V 2.3.x-x and lower.

Higher firmware versions can cause a higher data volume due to their increased functional range.

Calculating Data Volumes

The data volume calculation depends on which Fronius Datamanager functions are activated.

Function	Data volume	
Make real-time data available in Fronius Solar.web	Once ¹⁾	150 bytes 32 KB/h
View real-time data in Fronius Solar.web	Current Total View per sensor card/sensor box	42 KB/h + 300 KB/h
	Current Comparison View per inverter	13 KB/h + 4 KB/h
	Home	0 KB/h
	System Comparison View	0 KB/h
Send archived data/logging data to Fronius Solar.web	(Memory sectors per day ²⁾ x 4 KB) + 8 KB Transmission time ³⁾	(600 bytes/min)
Sending service messages or errors	For daily sending per service message or error	1 KB/day + 300 bytes
	For immediate sending per service message or error	1 KB

1) Only after a restart or if the internet connection has been disconnected

2) Calculation of memory sectors per day according to chapter "Logging", section "Calculating memory capacity"

3) Depending on the quality of the internet connection

IMPORTANT! Since the values listed in the table are "rough data" for Fronius Datamanager and the provider's bill may show discrepancies as a result of the various different ways of calculating the transfer volume, the total values should be increased by 10–20%.

If the functions have been deactivated, no data volume is generated.

A certain data volume is also required to update the Fronius Datamanager firmware. This data volume depends on the size of the relevant update package and cannot therefore be taken into account for any advance calculation of the data volume.

IMPORTANT! Fronius recommends a flat rate in order to avoid unforeseeable data volumes.

Calculation examples

Example 1 - Home System

1 inverter;	+ 0.15 KB
No Fronius Sensor Card/Box;	
Fronius Datamanager has a 24-hour internet connection;	+ 32 KB/h x 24 h = 768 KB
Archived data is sent to Fronius Solar.web;	
30 minutes transfer time;	+ 0.6 KB/min x 30 min = 18 KB
inverters operate 14 h/day;	
15 minutes storage interval;	+ (1 memory sector/day x 4 KB) + 8 KB = 12 KB
(This results in 1 memory sector per day in accordance with the section "Calculating memory capacity")	
Real-time data is viewed over a 15-minute period every day	+ 42 KB/h x 0.25 h = 10.5 KB
1 service message sent each day to confirm average error rate	+ 1 service message x 1 KB = 1 KB
Subtotal without safety	0.15 KB 768.00 KB 18.00 KB 12.00 KB 10.50 KB 1.00 KB
	<hr/> 809.65 KB
A 10% safety factor is added to the calculation	809.65 KB + 10%
Final result	890.615 KB/day

Example 2 - Large System

100 inverters; + 0.15 KB
 10 sensor cards/sensor boxes;
 Fronius Datamanager has a + 32 KB/h x 24 h = 768 KB
 24-hour internet connection;

Archived data is sent to Fronius Solar.web;
 120 minutes transfer time; + 0.6 KB/min x 120 min = 72 KB
 inverters operate 14 h/day;
 5 minutes storage interval; + (173 memory sectors/day x 4 KB)
 (This results in 173 memory sectors per + 8 KB
 day in accordance with the section "Calculating memory capacity") = 700 KB

The current Total View and the current Comparison View are viewed over a two-hour period every day + 42 KB/h x 2 h
+ 300 KB/h x 10 x 2 h
+ (13 KB/h + 100 x 4 KB/h) x 2 h
= 6910 KB

50 service messages sent each day to confirm average error rate + 50 service messages x 1 KB = 50 KB

Subtotal without safety 0.15 KB
768.00 KB
72.00 KB
700.00 KB
6910.00 KB
50.00 KB

8,500.15 KB

A 10% safety factor is added to the calculation 8,500.15 KB + 10%

Final result	9,350.165 KB/day (approx. 9.35 MB/day)
---------------------	--

General information for the network administrator

Requirements



NOTE! Configuring a network for Fronius Datamanager requires knowledge of network technology.

If Fronius Datamanager is being integrated into an existing network, the Fronius Datamanager address must be adapted to the network.

Example: Network address range = 192.168.1.x, subnet mask = 255.255.255.0

- An IP address between 192.168.1.1 and 192.168.1.254 must be assigned to Fronius Datamanager.
- The IP address selected may not be already assigned in the network.
- The subnet mask must correspond to the existing network (e.g. 255.255.255.0).

If Fronius Datamanager will be sending service messages and/or data to Fronius Solar.web, then a gateway address and a DNS server address must also be entered. Fronius Datamanager uses the gateway address to access the Internet. The IP address of the DSL router can be used as a gateway address, for example.

IMPORTANT!

- Fronius Datamanager may not have the same IP address as the PC/laptop!
- Fronius Datamanager cannot connect to the Internet spontaneously. A router must be used for a DSL connection to the Internet.

If you are using the WLAN network connection, the Fronius Datamanager must be equipped with a WLAN function and a WLAN antenna suitable for the inverter.

General firewall settings

The firewall must be configured as follows in order to use the different Fronius Datamanager functions:

	49049/UDP output	15015/TCP input	80/TCP input
Sending service messages	x	-	-
Connecting to datalogger via 'Fronius Solar.web'	x	-	-
Connecting to datalogger via 'Fronius Solar.access'	-	x	x
Access to the Fronius Datamanager web interface	-	-	x

Service messages are sent via Fronius Solar.web.

Sending service messages via a DSL Internet connection

Normally, no additional router configuration is required for a regular DSL Internet connection for accessing 'Fronius Solar.web' and/or sending service messages, because connections from the LAN to the Internet are open.

Using Fronius Solar.web and sending service messages

However, an internet connection is required to use Fronius Solar.web and send service messages.

Fronius Datamanager cannot connect to the Internet spontaneously. A router must be used for a DSL connection to the Internet.

Controls, connections and indicators

Safety



WARNING! Operating the device incorrectly can cause serious injury and damage. Do not use the functions described until you have thoroughly read and understood the following documents:

- these operating instructions
- all operating instructions for system components, especially the safety rules

Controls, Connections and Indicators

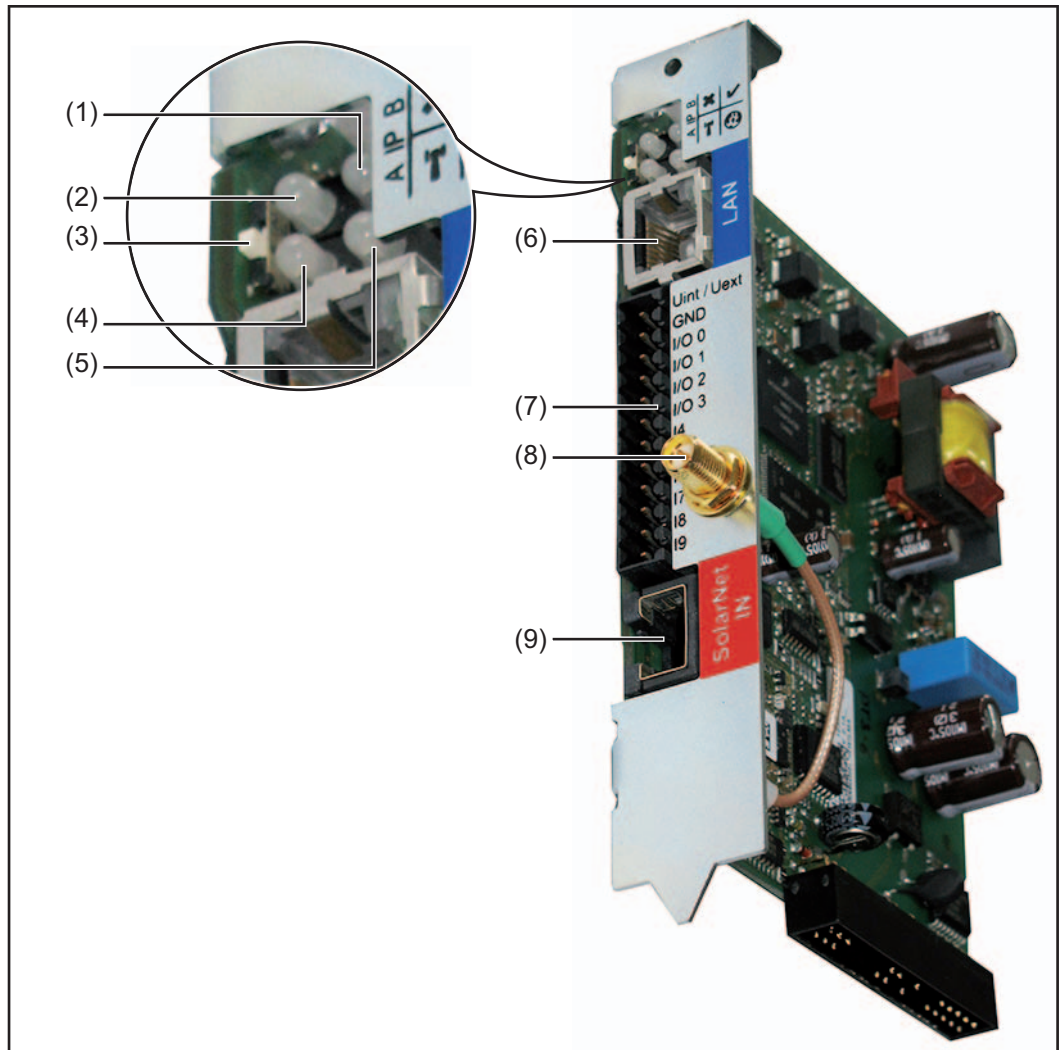

No.	Function
(1)	Supply LED
	- lights up green: When sufficient power is coming from Fronius Solar Net; Fronius Datamanager is operational ✓
	- does not light up: When no power or not enough power is coming from Fronius Solar Net; an external power supply is required
	- flashes red: During an update process
	IMPORTANT! Do not interrupt the power supply during an update process
	- lights up red: the update process failed

No.	Function	
(2)	Connection LED	x
	<ul style="list-style-type: none"> - lights up green: When there is an active connection within Fronius Solar Net - lights up red: When there is an interrupted connection within Fronius Solar Net 	
(3)	IP switch	
	for changing the IP address:	
	A default IP address "169.254.0.180" Fronius Datamanager uses the fixed IP address 169.254.0.180; the fixed IP address is used for a direct connection to a PC via LAN without first having to pre-configure the PC	
	B assigned IP address Fronius Datamanager operates using an assigned IP address (factory setting 192.168.1.180); The IP address can be set on the Fronius Datamanager web interface	
(4)	WiFi LED	T
	<ul style="list-style-type: none"> - lights up green: When there is an existing network connection - lights up red: When there is no existing network connection - does not light up: Plug-in card without WiFi 	
(5)	Solar Web LED connection	⊕
	<ul style="list-style-type: none"> - lights up green: When there is an existing connection to Fronius Solar.web - lights up red: When there is no connection to Fronius Solar.web, but one is required - does not light up: When no connection to Fronius Solar.web is required 	
(6)	LAN connection socket Ethernet interface colored blue for connecting an Ethernet cable	
(7)	I/Os digital inputs and outputs	
	Digital inputs: I/O 0 – I/O 3, I 4 – I 9 voltage level: low = min. 0 V – max. 1.8 V; high = min. 3 V – max. 30 V input currents: dependent on input voltage; input resistance = 46 kOhm	
	Digital outputs: I/O 0 – I/O 3 Switching capacity when supplied by the Datamanager plug-in card: 3.2 W, 10.7 V in total for all 4 digital outputs	
	Switching capacity when supplied by an external power supply with min. 10.7 – max. 24 V DC, connected to Uint / Uext and GND: 1 A, 10.7 – 24 V DC (de- pending on the external power supply) per digital output	
	The connection to the I/Os is made via the supplied mating connector.	
(8)	WiFi Antenna Socket (only for versions with WiFi) used for connecting the WiFi antenna or the WiFi antenna extension cable	
(9)	Solar Net IN connection socket Fronius Solar Net input colored red for connecting other DATCOM components (e.g., inverters, sensor cards, etc.)	

Schematic Connection of I/Os

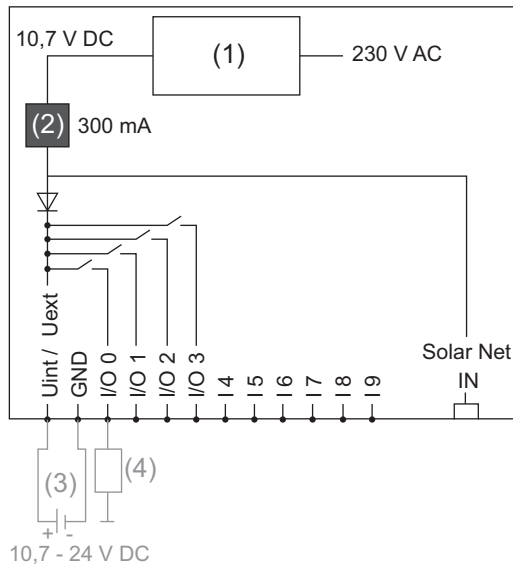

Supply via Datamanager plug-in card:

- (1) Power supply
- (2) Current limit

Supply via external power supply:

- (3) External power supply
- (4) Load

NOTE! When the supply is via an external power supply, the external power supply must be galvanically isolated.

Cabling

Fronius Solar Net clients Inverters with Fronius Datamanager or Fronius Com Card, DATCOM components with external housing or other DATCOM components will hereinafter be referred to as Fronius Solar Net.

Fronius Solar Net Client Cabling The data connection for the Fronius Solar Net client is a 1:1 connection using 8-pin data cables and RJ-45 plugs. The overall line length in a Fronius Solar Net ring must not exceed 1000 m.

Requirements for the Solar Net Data Cables Shielded CAT5 (new) and CAT5e (old) cables compliant with ISO 11801 and EN 50173 must be used for the Fronius Solar Net client cabling. Other cables are not permitted.



IMPORTANT! Do not use ISO/IEC-11801 U/UTP cables!

Permitted cables:

- S/STP
- F/STP
- S/FTP
- F/FTP
- SF/FTP
- S/UTP
- F/UTP
- U/FTP
- U/STP

The shield must be crimped onto a CAT5-compatible shielded plug.

Due to the fact that the wires in Ethernet cables are twisted, you must make sure the twisted pairs of wires are assigned correctly for cabling in accordance with TIA/EIA-568B:

Fronius Solar Net contact	Pair no.	Color
1 +12 V	3	 white/orange line
2 GND	3	 orange/white line or orange
3 TX+ IN, RX+ OUT	2	 white/green line
4 RX+ IN, TX+ OUT	1	 blue/white line or blue
5 RX- IN, TX- OUT	1	 white/blue line
6 TX- IN, RX- OUT	2	 green/white line or green
7 GND	4	 white/brown line
8 +12 V	4	 brown/white line or brown

Cabling compliant with TIA/EIA-568B

- Make sure that the wires are assigned correctly.
- When setting up an independent ground connection (e.g., in patch panels), make sure that the shield is grounded on one side of the cable only.

The following structured cabling standards must generally be observed:

- EN 50173-1 for Europe
- ISO/IEC 11801:2002 internationally
- TIA/EIA 568 for North America

Rules for use of copper cables apply.

**Preassembled
data cables**

The following preassembled data cables are available from Fronius:

- CAT5 cable 1 m ... 43,0004,2435
- CAT5 cable 20 m ... 43,0004,2434
- CAT5 cable 60 m ... 43,0004,2436

The cables listed above are 8-pin, 1:1 LAN network cables, shielded and twisted, including RJ 45 plugs.

IMPORTANT! Data cables are not UV resistant. They should be protected from sunlight when laid outdoors.

Installing Fronius Datamanager

Installing Fronius Datamanager – LAN overview

Safety



WARNING! Operating the device incorrectly can cause serious injury and damage. Do not use the functions described until you have thoroughly read and understood the following documents:

- these operating instructions
- all operating instructions for system components, especially the safety rules



NOTE! Installing Fronius Datamanager requires knowledge of network technology.

Installing Fronius Datamanager – LAN Overview

- 1 Adjust the network settings for the Fronius Datamanager on the PC/laptop



See section "Adjusting network settings for PC/laptop"

- 2 Insert Fronius Datamanager into the inverter



See section "Inserting Fronius Datamanager into an inverter"

- 3 Insert blue Ethernet cable into Fronius Datamanager (LAN connection socket)

- 4 Insert terminating plug into Fronius Datamanager (Solar Net IN connection socket)

- 5 Insert blue Ethernet cable into the PC/laptop



See section "Installing Fronius Datamanager in Fronius Solar Net"

- 6 Switch IP switch on Fronius Datamanager to position - A -

- 7 Close the inverter and switch it on

- 8 After approx. 1 minute, open the browser on the PC/laptop and enter the following address:

http://169.254.0.180

The Fronius Datamanager web interface appears.



NOTE! If a connection to Fronius Datamanager is not established, check the network settings:

- System Controls / Network and Sharing Center / LAN Connection / Properties (General) / Internet Protocol (TCP/IP) / Properties / Activate "Obtain IP Address Automatically" + "Obtain DNS Server Address Automatically"
- Internet Browser / Extras / Internet Options / Connections / LAN Settings / Deactivate "Use Proxy Server for LAN"



See section "Starting for the First Time – Opening the Fronius Datamanager Web Interface"

Upon initial installation of Fronius Datamanager a message indicating the time and date is displayed.

- 9 Click on the message and set the time and date

If the message does not appear:
Settings / TIME/DATE / Set Time and Date

 See section "Settings – Time/Date"

10 Settings / Internet Connection / LAN – save

 See section "Settings – Internet Connections"

11 Settings / LAN / select:
"dynamic"(assign host name)
or
"static" (enter data)

 See section "Settings – LAN"

12 Settings / SOLAR.WEB / Enter Data, save

 See section "Settings – Solar.web"

13 System Information / Note Datalogger ID (required for registration in Solar.web)

 See section "Services – System Information"

14 Turn off and open inverters

15 Switch IP switch on Fronius Datamanager back to position - B -

16 Close the inverter and switch it on

17 Disconnect the blue Ethernet cable from PC/laptop

18 Insert the blue Ethernet cable into the router

 See section "Starting up Fronius Datamanager – LAN"

Installing Fronius Datamanager – WiFi overview

Safety



WARNING! Operating the device incorrectly can cause serious injury and damage. Do not use the functions described until you have thoroughly read and understood the following documents:

- these operating instructions
- all operating instructions for system components, especially the safety rules



NOTE! Installing Fronius Datamanager requires knowledge of network technology.

Installing Fronius Datamanager – WiFi Overview

- 1 Adjust the network settings for the Fronius Datamanager on the PC/laptop



See section "Adjusting network settings for PC/laptop"

- 2 Insert Fronius Datamanager into the inverter



See section "Inserting Fronius Datamanager into an inverter"

- 3 Install WiFi antenna



See section "Installing WiFi Antenna"

- 4 Insert blue Ethernet cable into Fronius Datamanager (LAN connection socket)

- 5 Insert terminating plug into Fronius Datamanager (Solar Net IN connection socket)

- 6 Insert blue Ethernet cable into the PC/laptop



See section "Installing Fronius Datamanager in Fronius Solar Net"

- 7 Switch IP switch on Fronius Datamanager to position - A -

- 8 Close the inverter and switch it on

- 9 After approx. 1 minute, open the browser on the PC/laptop and enter the following address:

`http://169.254.0.180`

The Fronius Datamanager web interface appears.



NOTE! If a connection to Fronius Datamanager is not established, check the network settings:

- System Controls / Network and Sharing Center / LAN Connection / Properties (General) / Internet Protocol (TCP/IP) / Properties / Activate "Obtain IP Address Automatically" + "Obtain DNS Server Address Automatically"
- Internet Browser / Extras / Internet Options / Connections / LAN Settings / Deactivate "Use Proxy Server for LAN"



See section "Starting for the First Time – Opening the Fronius Datamanager Web Interface"

Upon initial installation of Fronius Datamanager a message indicating the time and date is displayed.

10 Click on the message and set the time and date

If the message does not appear:
Settings / TIME/DATE / Set Time and Date

 See section "Settings – Time/Date"

11 Settings / Internet Connection / WiFi – save

 See section "Settings – Internet Connections"

12 Settings / WiFi / select:
"dynamic" (assign host name)
or
"static" (enter data)

 See section "Settings – WiFi"

13 Settings / WiFi MANAGEMENT / Update Networks

 See section "Settings – WiFi Management"

14 Settings / SOLAR.WEB / Enter Data, save

 See section "Settings – Solar.web"

15 System Information / Note Datalogger ID (required for registration in Solar.web)

 See section "Services – System Information"

16 Turn off and open inverters

17 Switch IP switch on Fronius Datamanager back to position - B -

18 Disconnect the blue Ethernet cable from Fronius Datamanager

19 Close the inverter and switch it on

20 Disconnect the blue Ethernet cable from PC/laptop

 See section "Starting up Fronius Datamanager – WiFi"

Network settings for PC/laptop

General

The PC/laptop is also a member of the network and must also be assigned a unique network address like Fronius Datamanager.

If the PC is already integrated in the network, no further settings are required.

Network settings for PC/laptop

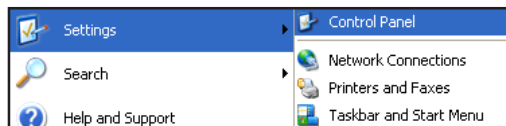

- 1 Start / Control Panel / Network and Internet Connections
- 2 Double-click on "Network Connections"

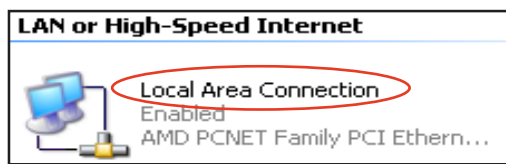

- 3 Double-click on "Local Area Connection"

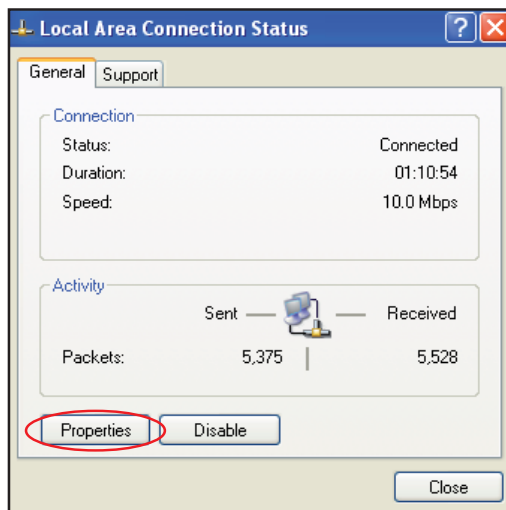

- 4 Click on the "Properties" button in the "General" tab

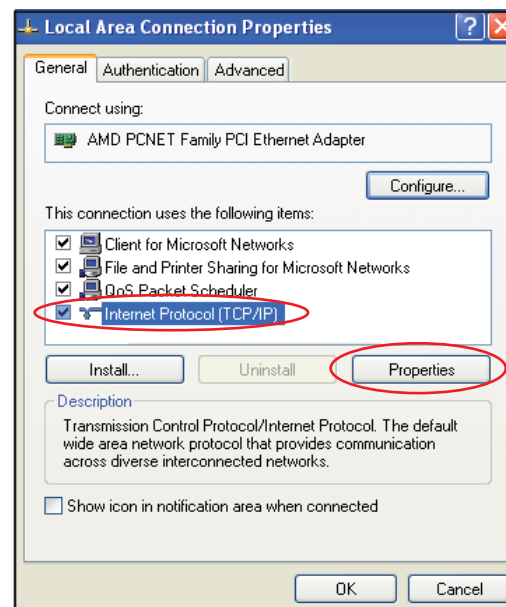

- 5 Click on "Internet Protocol (TCP/IP)"
- 6 Click on the "Properties" button

The "Internet Protocol (TCP/IP) Properties" window will appear.

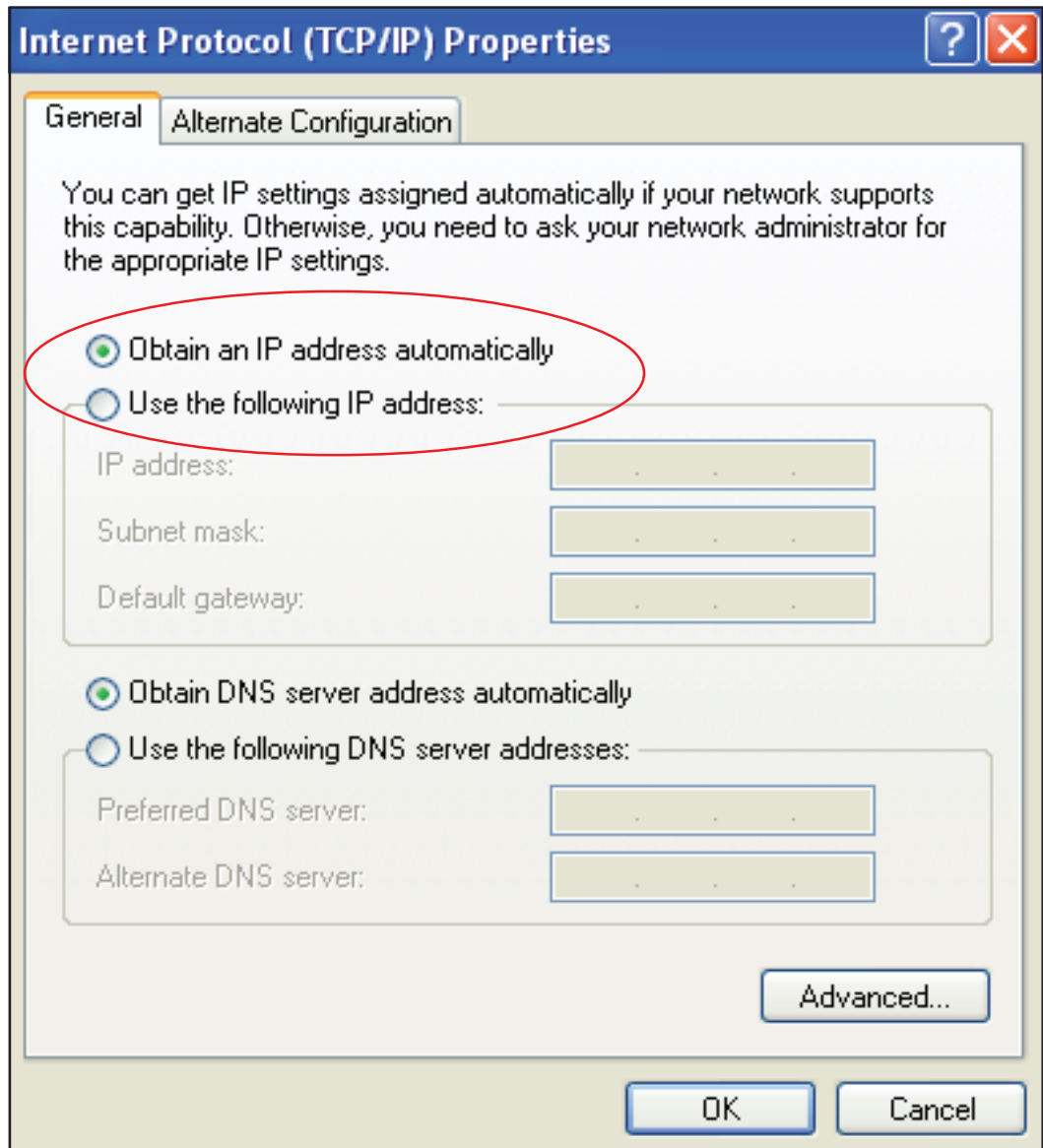

If a DHCP server is available in the network:

- 7 Select "Obtain an IP address automatically"

If a DHCP server is not available in the network:

- 7a Select "Use the following IP address"
- 7b Assign a unique IP address to the PC/laptop

Example: Network address range = 192.168.1.x, subnet mask = 255.255.255.0

- An IP address between 192.168.1.1 and 192.168.1.254 must be assigned to the PC/laptop.
- The IP address selected may not be already assigned in the network.
- The subnet mask must correspond to the existing network (e.g. 255.255.255.0).
- The "Default gateway" setting is not relevant for the Fronius Datamanager connection.

IMPORTANT! The PC/laptop must not have the same IP address as Fronius Data-manager!

- 8 Activate "Obtain DNS server address automatically"

Internet options for PC/laptop

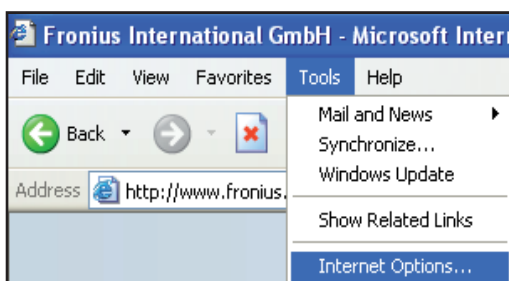

- 1 Open the internet browser (e.g. Microsoft Internet Explorer)
- 2 Click on "Tools"
- 3 Click on "Internet Options"

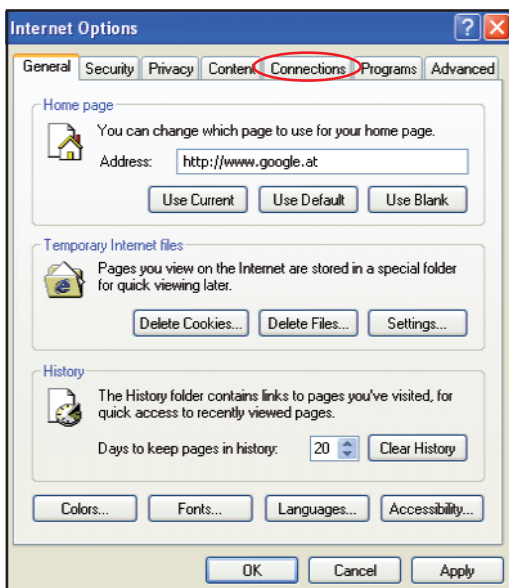

- 4 Click on the "Connections" tab

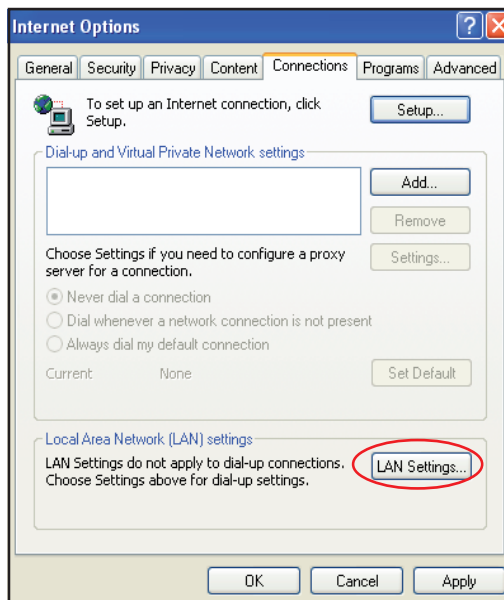

5 Click on the "LAN settings" button at the bottom

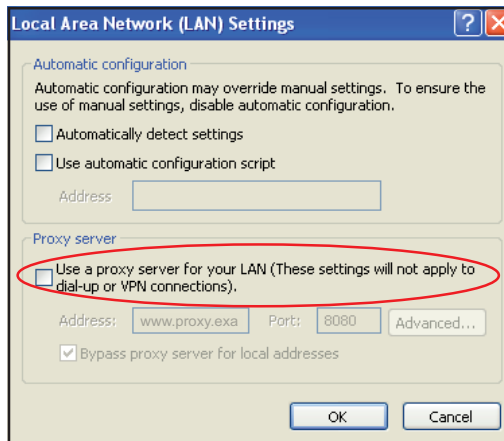

6 When the "Use a proxy server for your LAN" option is not activated like in the picture, the setting options below it are grayed and not accessible.

If "Use a proxy server for your LAN" is activated:

- Click on "Advanced"

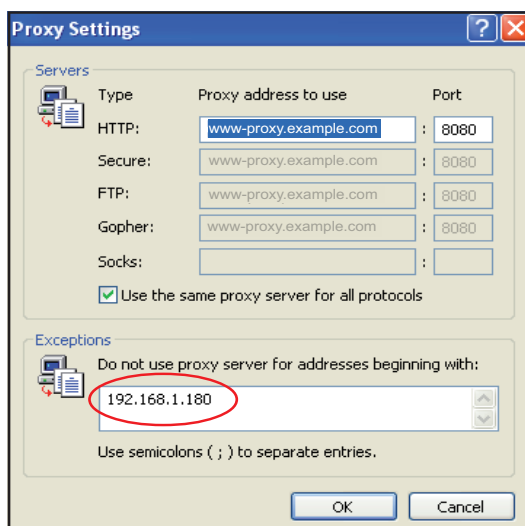

- Enter the IP address for Fronius Data-manager in the "Exceptions" field, e.g. 192.168.1.180
- Click on "OK"

Inserting Fronius Datamanager into an inverter

General

Please see the operating instructions for the respective inverter for information regarding plug-in card installation. Please note the safety and warning information in your inverter's operating instructions.

IMPORTANT! Before inserting the Fronius Datamanager plug-in card, remove any existing Fronius Com Card, Fronius Power Control Card, or Fronius Modbus Card!

Safety



WARNING! An electric shock can be fatal. Danger from grid voltage and DC voltage from solar modules.

- The connection area should only be opened by a licensed electrician.
- The separate power stage set area should only be disconnected from the connection area after first being disconnected from the grid power.
- The separate power stage set area should only be opened by Fronius-trained service personnel.

Before making any connections, make sure that the AC and DC sides are disconnected from the inverter, e.g.:

- Switch off the AC automatic circuit breaker for the inverter
- Cover solar modules

Please observe the 5 safety rules.



WARNING! An electric shock can be fatal. Danger from residual voltage from capacitors.

You must wait until the capacitors have discharged.



NOTE! Follow general ESD precautions when handling plug-in cards.

**Fronius Dataman-
ager plug-in posi-
tions**

The Fronius Dataman-ager plug-in position is specified for each inverter type:

Inverter	Plug-in position
Fronius IG 15 - 60	ENS plug *)
Fronius IG 300 - 500	ENS plug *)
Fronius IG Plus, Fronius IG Plus V	on the far right, unless a ML-MON plug-in card is present
Fronius CL	on the far right, unless a ML-MON plug-in card is present

*) If an ENS plug-in card has been inserted into an ENS slot:
Insert Fronius Dataman-ager in the next slot to the right of the ENS slot.

IMPORTANT!

The next slot must remain empty!

Do not remove an inserted ENS plug-in card under any circumstances!

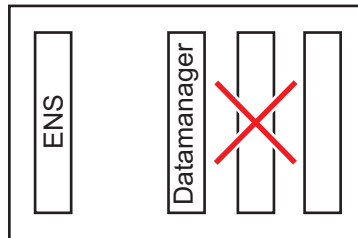

Installing and connecting WLAN antennas

General

If the Fronius Datamanager is equipped with WLAN, the WLAN antenna must be installed either inside or outside the inverter, depending on which inverter is being used.

IMPORTANT! Always follow the relevant operating instructions when opening an inverter. Observe the safety guidelines.

Fronius IG, Fronius IG Plus, Fronius IG Plus V, Fronius CL: Installing and connecting antennas

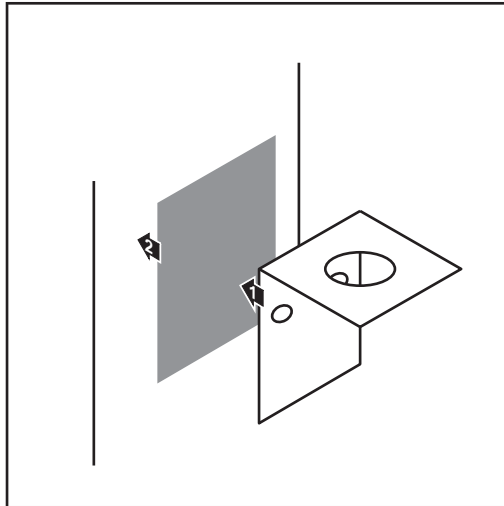

- 1 Use the double-sided adhesive tape to fasten the mounting bracket to the outside of the inverter housing or, if suitable for the antenna cable, secure it in a position near the inverter

IMPORTANT! The double-sided adhesive tape only reaches its maximum bond strength after 24 hours.

IMPORTANT! The mounting bracket may not be screwed to the inverter housing. It may however be fitted in a nearby position. The relevant screws are not included in the scope of delivery and must be selected by the installer.

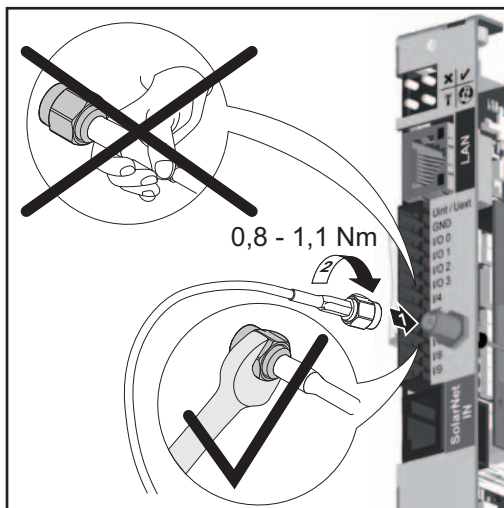

- 2 Connect the antenna cable to Fronius Datamanager
- 3 Run the antenna cable out through the "DATCOM Opening" on the inverter
- 4 If possible, secure the cable with a strain relief device
- 5 Close or seal the "DATCOM Opening" in accordance with the inverter operating instructions

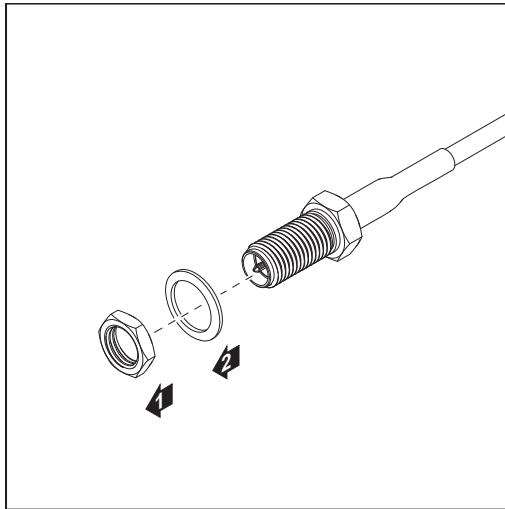

- 6 Remove the hex nut and washer from the outside thread of the antenna cable



NOTE! To avoid damaging the antenna, only use the hexagonal head to fasten the antenna.

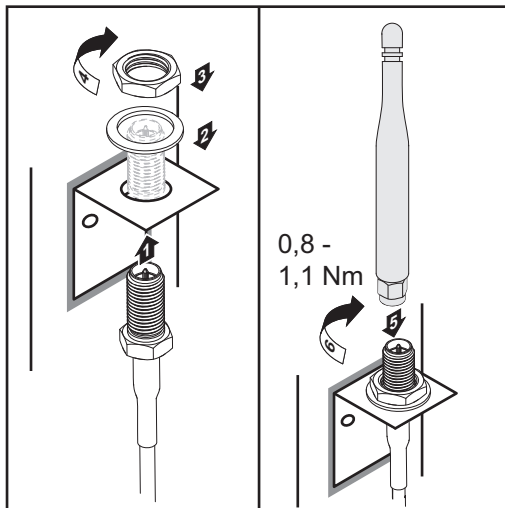

- 7 Run the antenna cable through the drill hole on the mounting bracket
- 8 Attach the lock washer and screw on the hex nut
- 9 Screw on the antenna

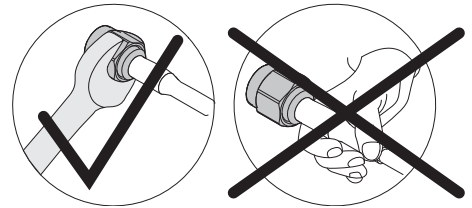

Fronius IG USA,
 Fronius IG Plus
 USA, Fronius IG
 Plus V USA: In-
 installing and Con-
 necting Antennas

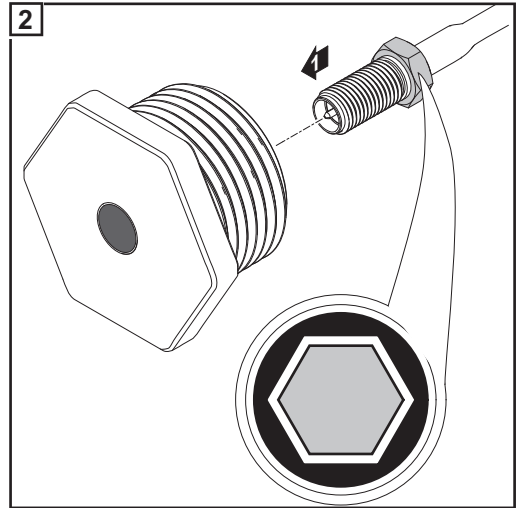
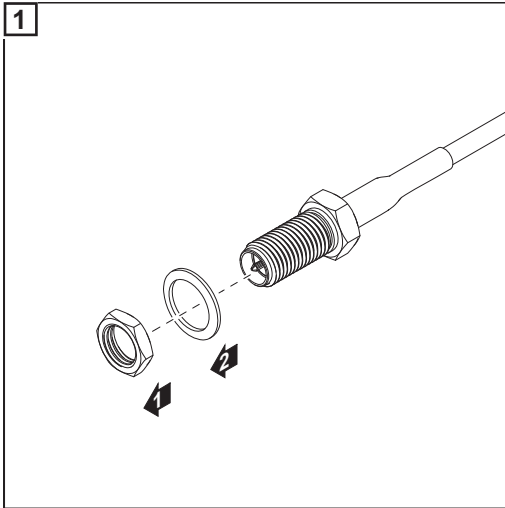

CAUTION! Danger of short circuit caused by loose metal parts from knockouts. Loose metal parts in the inverter may cause short circuits when the inverter is powered up. When removing knockouts, make sure that

- no loose metal parts fall into the inverter
- any metal pieces that do fall into the inverter are removed immediately.

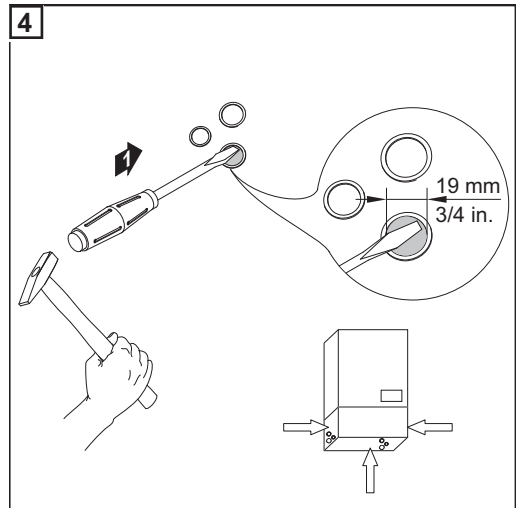
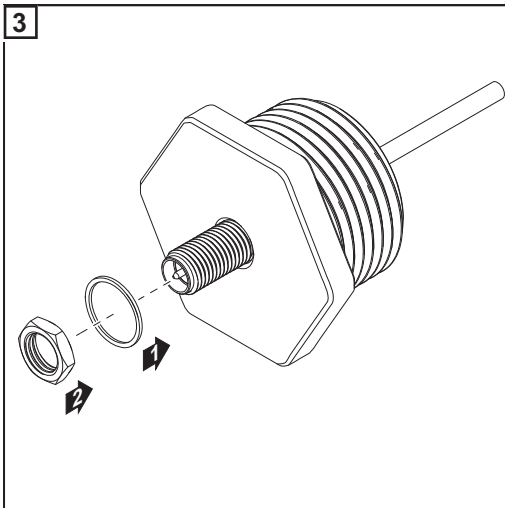

NOTE! In order to ensure leak-tightness, the sealing ring must be fitted to the antenna screw joint before inserting the antenna screw joint into the inverter housing.

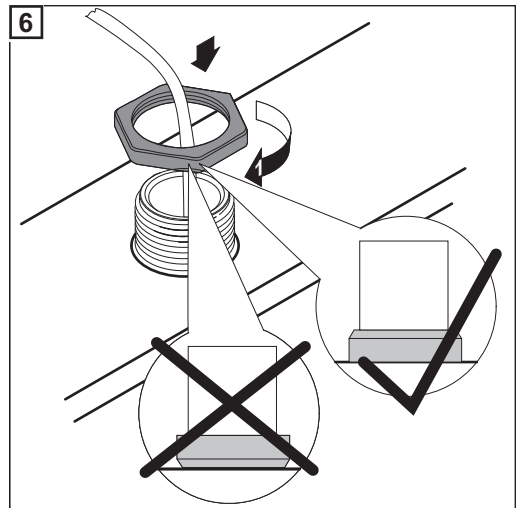
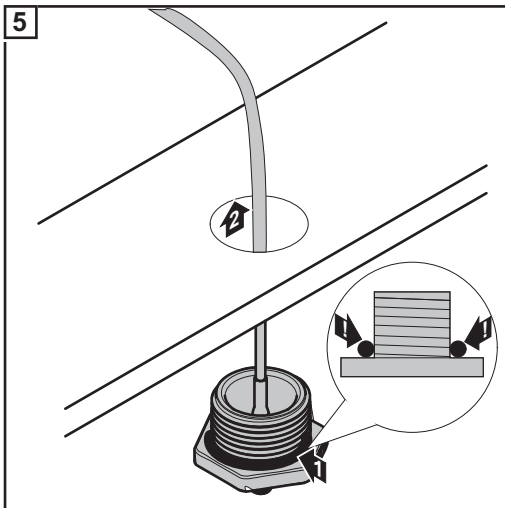

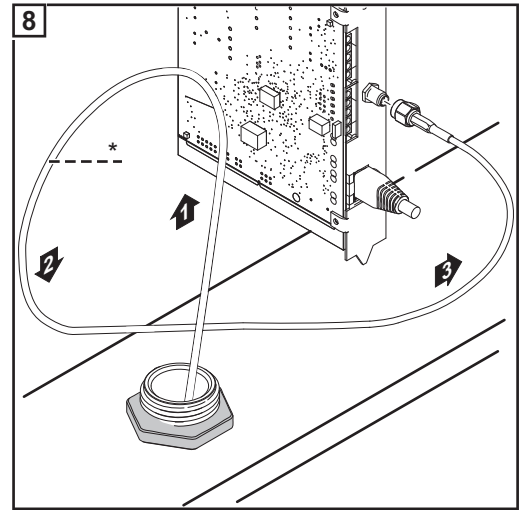
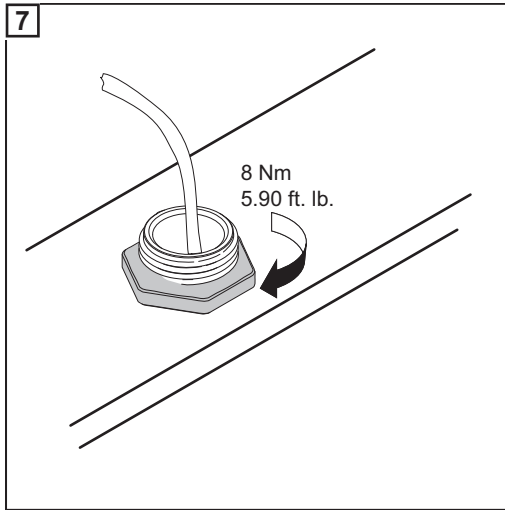

* Bending radius of the antenna cable: at least 25.4 mm/1 in.



NOTE! To avoid damaging the antenna, only use the hexagonal head to fasten the antenna.

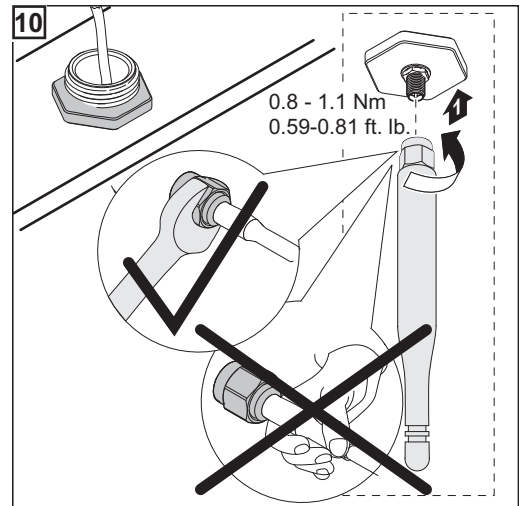
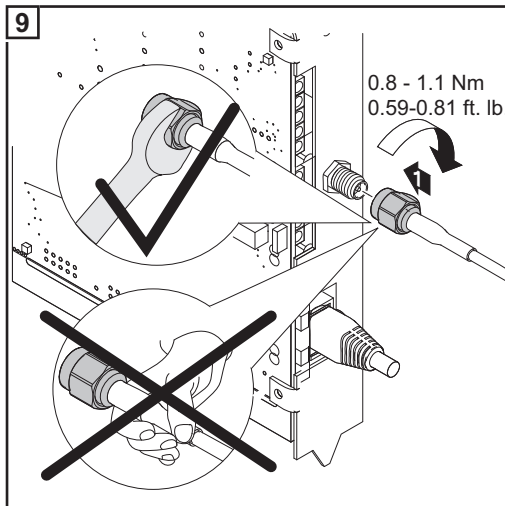

Installing Fronius Datamanager in Fronius Solar Net

Installing Inverters with Fronius Datamanager in Fronius Solar Net

CAUTION! DATCOM components and/or the PC/laptop may be seriously damaged if the Ethernet or Solar Net cables are connected incorrectly to Fronius Datamanager.

- The Ethernet cable should only be inserted into the LAN connection socket (colored blue).
- The Solar Net cable should only be inserted into the Solar Net IN connection socket (colored red).

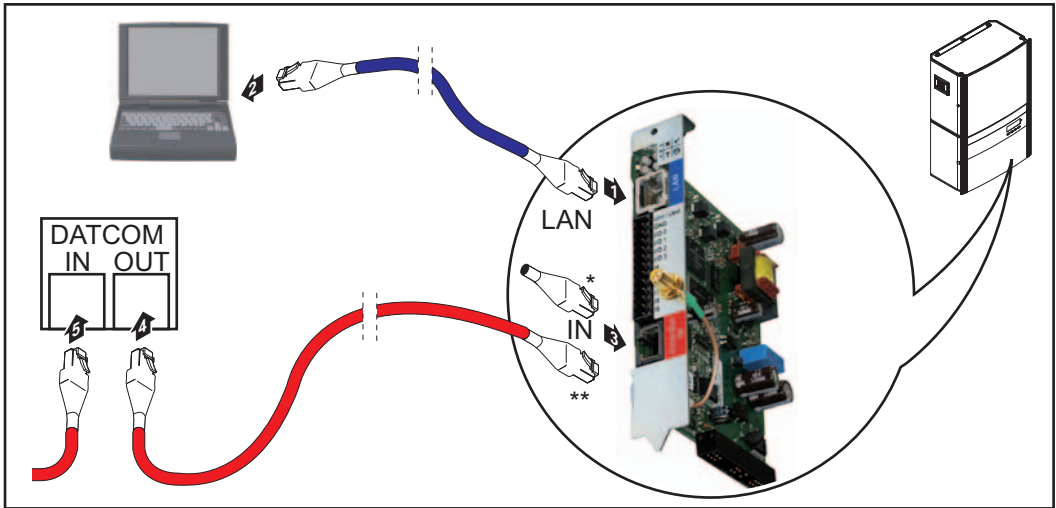

- * Terminating plug, if only one inverter with Fronius Datamanager is linked to a PC
- ** Solar Net Cable, if an inverter with Fronius Datamanager is linked to a PC and other DATCOM components

- 1 Insert and lay the Ethernet cable in the inverter like a data communication cable in accordance with the operating instructions for the inverter.
- 2 Insert the Ethernet cable into the LAN connection socket.
- 3 Insert the Ethernet cable into the PC/laptop or into a suitable network connection socket.
- 4 If only one inverter with Fronius Datamanager is being linked to a PC: Insert the terminating plug into the Solar Net IN connection socket

If other DATCOM components are connected to the network, besides the inverter with Fronius Datamanager:
Insert the Solar Net cable into the Solar Net IN connection socket of Fronius Datamanager.

- 5 Connect the other DATCOM components.

IMPORTANT! A terminating plug must be inserted into the empty IN connection socket of the last DATCOM component.

Starting for the First Time – Opening the Fronius Datamanager Web Interface

Starting for the First Time – Opening the Fronius Datamanager Web Interface



WARNING! An electric shock can be fatal. Danger from grid voltage and DC voltage from solar modules.

Before opening the inverter:

- You must wait until the capacitors have discharged.
- Follow the operating instructions when opening the inverter.
- Observe the safety rules and safety instructions contained in the inverter's operating instructions.

To start up Fronius Datamanager, the plug-in card must be installed in the inverter and in the Fronius Solar Net.

- 1 In the inverter on the Fronius Datamanager, switch the IP switch to position - A - as per the figure:

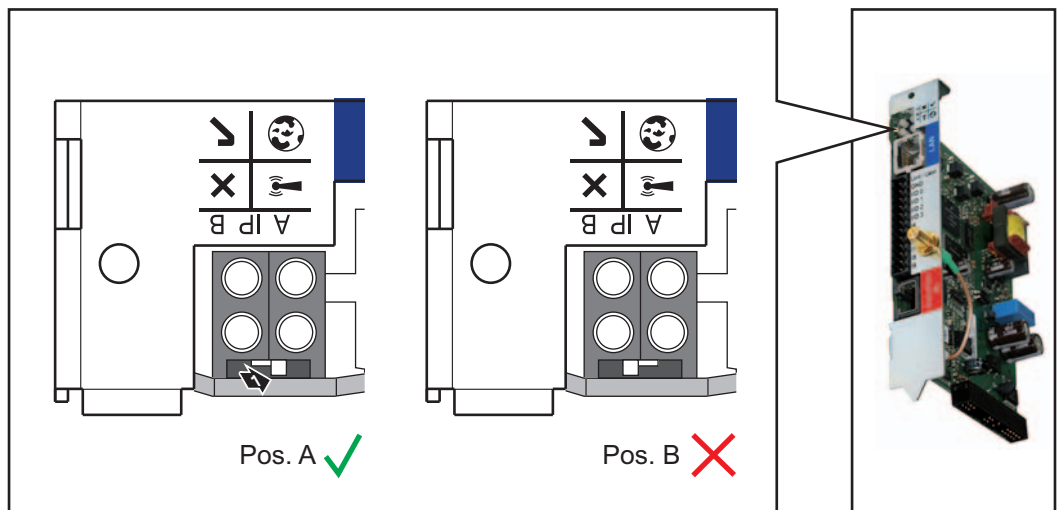

- 2 Close and switch on the inverter in accordance with the operating instructions
- 3 Wait for approx. 1 minute until the connection to Fronius Datamanager is established. In the task bar of the PC/laptop, the "Connectivity" symbol can be displayed:



- 4 Open the PC's/laptop's internet browser (e.g., Microsoft Internet Explorer)
- 5 Enter the following address in the address field:
`http://169.254.0.180;`

the Fronius Datamanager web interface will appear



NOTE! If a connection to Fronius Datamanager is not established, check the network settings:

- System Controls / Network and Sharing Center / LAN Connection / Properties (General) / Internet Protocol (TCP/IP) / Properties / Activate "Obtain IP Address Automatically" + "Obtain DNS Server Address Automatically"
- Internet Browser / Extras / Internet Options / Connections / LAN Settings / Deactivate "Use Proxy Server for LAN"

**Fronius Dataman-
ager Web Inter-
face – Overview**

The following data is displayed on the Fronius Dataman-ager web interface:

- (1) Current comparison view of all inverters in the Fronius Solar Net ring
- (2) System overview: Current / Day / Year / Total
- (3) Inverters
- (4) Sensors
- (5) Services
system information, network diagnostics, firmware update
- (6) The Settings menu
- (7) Other setting options

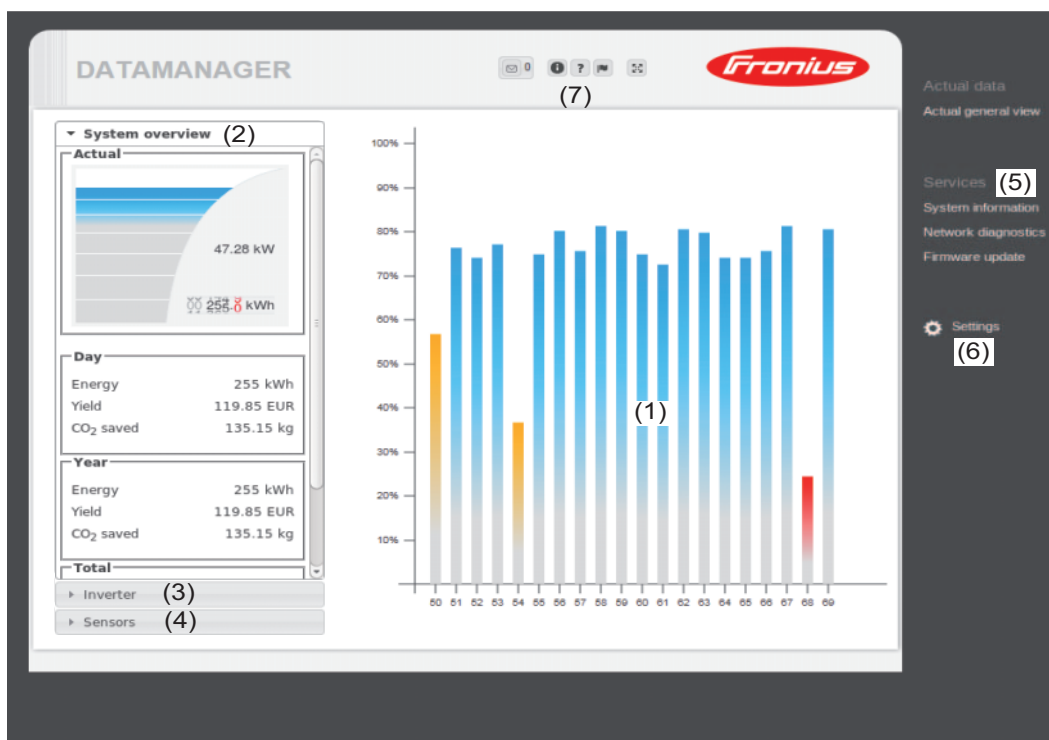

The Settings Menu

After clicking on "Settings," the Settings menu is opened on the Fronius Datamanager web interface.

The web interface is configured in the Settings menu.



Menu items in Settings menu

General Adjustment and Viewing of Menu Items

- 1 Connect to Fronius Datamanager
- 2 Click on "Settings"
- 3 Click on the desired menu item;
the desired menu item is opened
- 4 View menu item or edit accordingly
- 5 If found, click on the relevant button (e.g., Save, Synchronize, etc.)
and the changed data are accepted

- * Selected menu item
- ** The Date/Time setting is mandatory
- *** The menu items "Internet Connection," "WiFi," and "WiFi Management" are only present if the Fronius Datamanager plug-in card is equipped with WiFi.





Due to the different software versions, functions may be listed in these operating instructions that are not supported by Fronius Datamanager. These functions will not be displayed.

The current software version can be found at <http://www.fronius.com>.

Other settings options

Other settings options are shown in the top right corner of the Fronius Datamanager web interface:



- 
0 Display notifications
- 
 System information:
 Data logger ID, software version, hardware version, Solar Net connection, Solar.web connection
- 
 Help:
 Fronius Datamanager operating instructions, available in both English and German
- 
 Language:
 For setting the language (English or German)

The Fronius Datamanager web interface will appear in the language set in the browser or in the last language selected.
- 
 Expand contents:
 The Real-time Data/Settings menu is hidden

Starting up Fronius Datamanager – LAN

Starting Up Fronius Datamanager – LAN

- 1 Turn off inverter



WARNING! An electric shock can be fatal. Danger from grid voltage and DC voltage from solar modules.

Before opening the inverter:

- You must wait until the capacitors have discharged.
- Follow the operating instructions when opening the inverter.
- Observe the safety rules and safety instructions contained in the inverter's operating instructions.

- 2 Open the inverter

- 3 In the inverter on the Fronius Datamanager plug-in card, switch the IP switch to position - B - as per the figure:

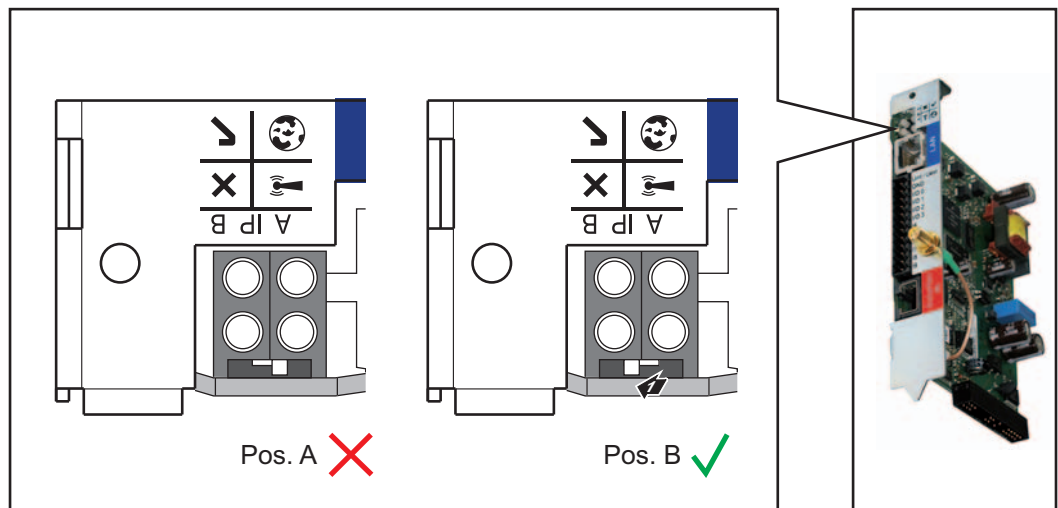

- 4 Close and switch on the inverter in accordance with the operating instructions
- 5 Disconnect the Ethernet cable from the PC/laptop
- 6 Insert the Ethernet cable into the router

Starting up Fronius Datamanager – WiFi

Starting Up Fronius Datamanager – WiFi

- 1 Turn off inverter



WARNING! An electric shock can be fatal. Danger from grid voltage and DC voltage from solar modules.

Before opening the inverter:

- You must wait until the capacitors have discharged.
- Follow the operating instructions when opening the inverter.
- Observe the safety rules and safety instructions contained in the inverter's operating instructions.

- 2 Open the inverter

- 3 In the inverter on the Fronius Datamanager plug-in card, switch the IP switch to position - B - as per the figure:

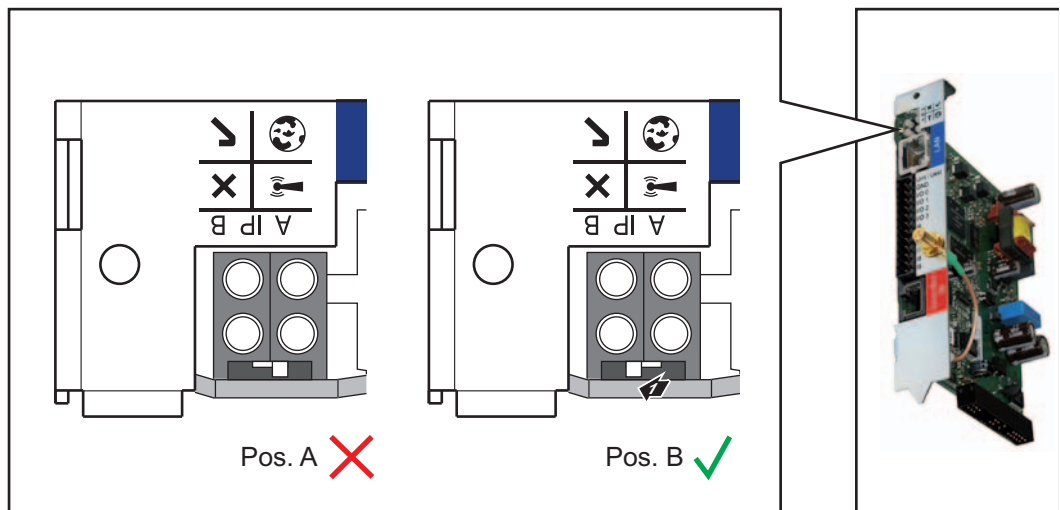

- 4 Disconnect the Ethernet cable from the Fronius Datamanager plug-in card and remove from the inverter

- 5 Close and switch on the inverter in accordance with the operating instructions

Connect to Fronius Datamanager

Connecting to Fronius Datamanager via internet browser

General

The connection to Fronius Datamanager via an internet browser is suitable for accessing current values with several PC users in a LAN (e.g. company networks, schools, etc.).

For example, total and daily yields can be accessed and/or inverter comparisons can be made on the Fronius Manager web interface.

Requirements

- At least a LAN or WLAN connection
- Internet browser (e.g. Microsoft Internet Explorer IE >= 9.0, Firefox 4, Google Chrome, etc.)
- PC/laptop in the same network segment as Fronius Datamanager

Connecting to Fronius Datamanager via Internet Browser

- 1 Open internet browser
- 2 Enter the IP address or the host name and the domain name for Fronius Datamanager in the address field;

the Fronius Datamanager web interface appears

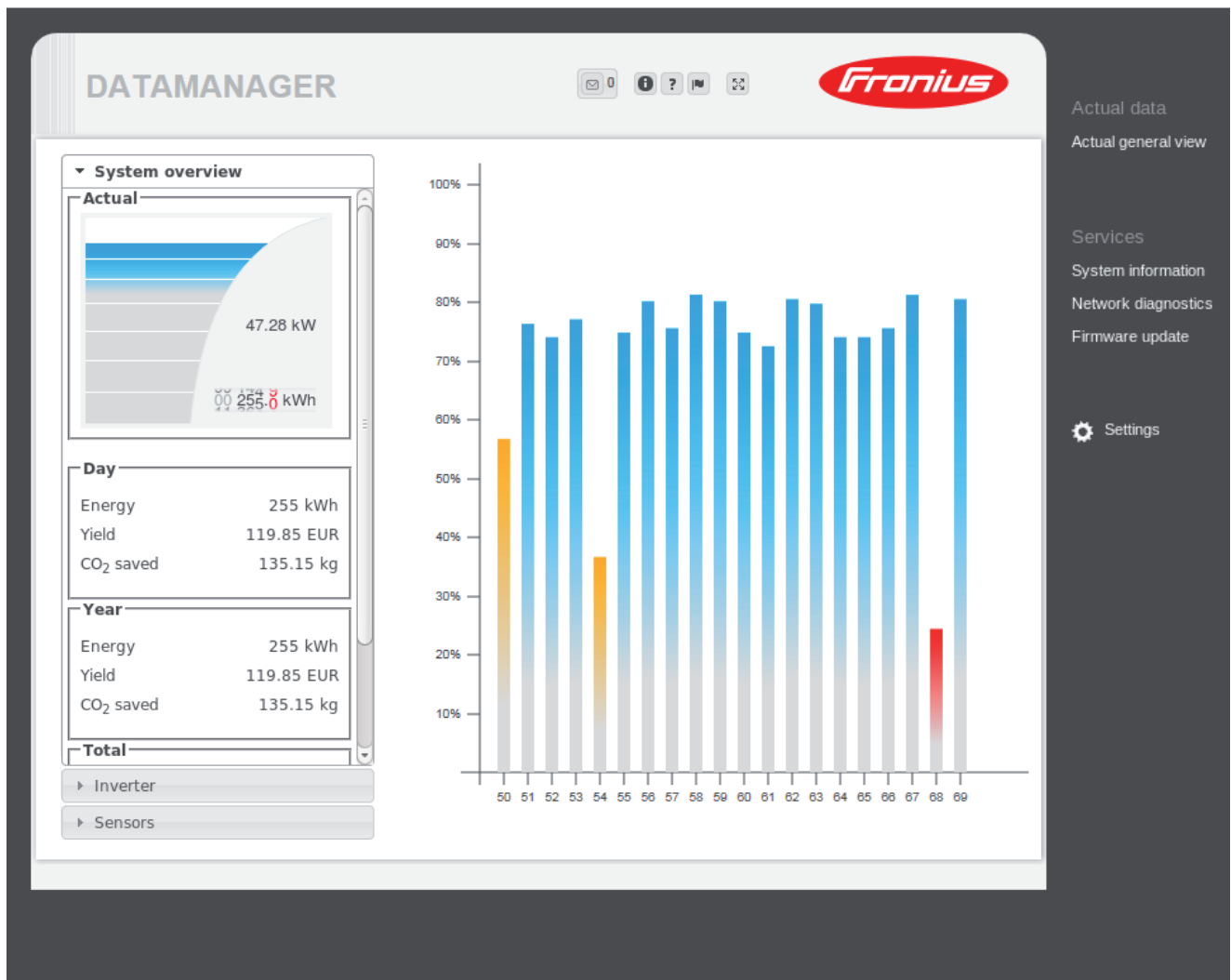

For the network administrator

To access the Fronius Datamanager web interface outside of the LAN:

- Configure the network router so that requests are forwarded to port 80/TCP on Fronius Datamanager

Connecting to Fronius Datamanager via Fronius Solar.access

General

The connection to Fronius Datamanager via Fronius Solar.access is suitable for detailed long-term data recording and offers full settings options and data preparation for the photovoltaic system.

Requirements

- At least a LAN or WLAN connection
- Internet browser: Microsoft Internet Explorer IE >= 7.0
- Datalogger network configuration in accordance with the section "Fronius Datamanager network configuration"
- PC/laptop in the same network segment as Fronius Datamanager
- PC/laptop operating system: Win 2000, Win XP, Win Vista or Win 7
- Fronius Solar.access software installed on PC/laptop
- Photovoltaic system created in Fronius Solar.access as per Fronius Solar.access on-line help (Open Fronius Solar.access / Administration / PV Systems / Set up PV System)

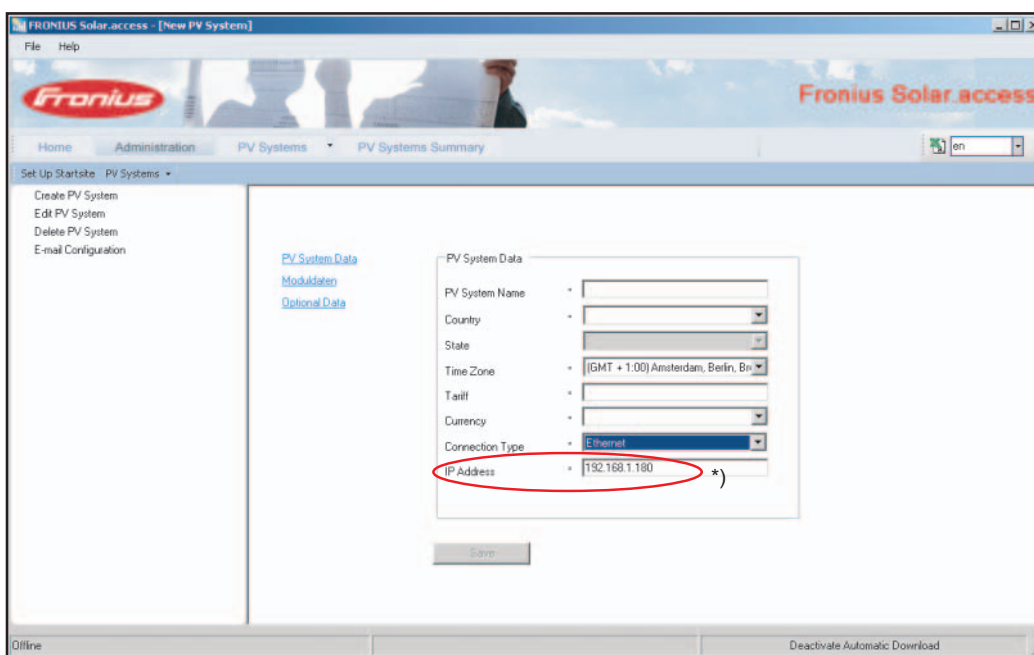

*) Assigned IP address or assigned host name for Fronius Datamanager

Connecting to Fronius Datamanager via Fronius Solar.access

- 1 Open the Fronius Solar.access software
- 2 Select "PV Systems"
- 3 Select the desired photovoltaic system

The connection is soon made to the selected photovoltaic system. The word "online" and the version of the Fronius Datamanager will be displayed in the bottom left status bar.

For the network administrator

To access the Fronius Datamanager outside of the LAN:

- Configure the network router so that requests are forwarded to port 80/TCP and port 15015/TCP on Fronius Datamanager

Connecting to Fronius Datamanager via the Internet and Fronius Solar.web

General

By connecting to Fronius Datamanager via the Internet and Fronius Solar.web, you can access archived data and real-time photovoltaic system data online from anywhere in the world.

You can also provide other users with guest access so that they can view your photovoltaic system, or you can make a comparison of several systems.

Function overview

Fronius Datamanager is connected to the Internet (e.g. via a DSL router). Fronius Datamanager regularly logs on to Fronius Solar.web and sends its saved data every day. Fronius Solar.web can actively contact Fronius Datamanager, e.g. to display real-time data.

Requirements

- Internet access
- Internet browser

IMPORTANT! Fronius Datamanager cannot connect itself to the Internet. A router must be used for a DSL connection to the Internet.

- Registration of photovoltaic system with Fronius Solar.web (1). The Fronius Datamanager ID is required for the registration. The ID is available in Settings/System Information.
- In order to access real-time data in Fronius Solar.web, the "Yes" selection option must be activated under "Send real-time data to Solar.web" in Fronius Datamanager (2).
- In order to access archived data in Fronius Solar.web, the "Daily at" or "Hourly" selection option must be activated under "Send archived data to Solar.web" in Fronius Datamanager (3).

The screenshot shows the 'SOLAR.WEB' settings page. On the left is a navigation menu with options: PASSWORDS, TIME/DATE, GENERAL, INVERTERS, SENSOR CARDS, LOGGING, INTERNET CONNECTION, LAN, WLAN, and WLAN MANAGEMENT. The 'SOLAR.WEB' option is highlighted in blue.

The main content area is titled 'Solar.web registration (1)'. It contains the following settings:

- Send current data to Solar.web:** Radio buttons for 'no' and 'yes (2)'. The 'yes' option is selected.
- Send archive data to Solar.web:** Radio buttons for 'never' and 'daily (3)'. The 'daily' option is selected.
 - Under 'daily', there is a dropdown menu set to 'At 0:00' and a 'Daily' button.
 - Below this, there are checkboxes for days of the week: Monday, Tuesday, Wednesday, Thursday, Friday, Saturday, and Sunday. All are checked.
 - Under 'daily', there is also a radio button for 'Hourly (3)'.
 - Below this, there is a grid of checkboxes for hours from 0:00 to 23:00. The hours 6:00, 7:00, 8:00, 9:00, 10:00, 11:00, 12:00, 13:00, 14:00, 15:00, 16:00, 17:00, 18:00, 19:00, 20:00, and 21:00 are checked.

At the bottom of the settings area are 'Save' and 'Cancel' buttons.

Accessing data from Fronius Datamanager via the Internet and Fronius Solar.web

To access real-time and archived data from Fronius Datamanager using Fronius Solar.web:

- 1 Open the "Solar Electronics" tab on the Fronius homepage (www.fronius.com)
- 2 Start Fronius Solar.web

For more information about Fronius Solar.web, see the online help.

For the network administrator

Configure the firewall so that the IP address of Fronius Datamanager can send data to port 49049/UDP of solarweb.fronius.com.

DSL routers usually enable you to send data to the Internet and therefore do not normally have to be configured.

Current Data in Fronius Datamanager

Current Data in Fronius Datamanager

Current Comparison View

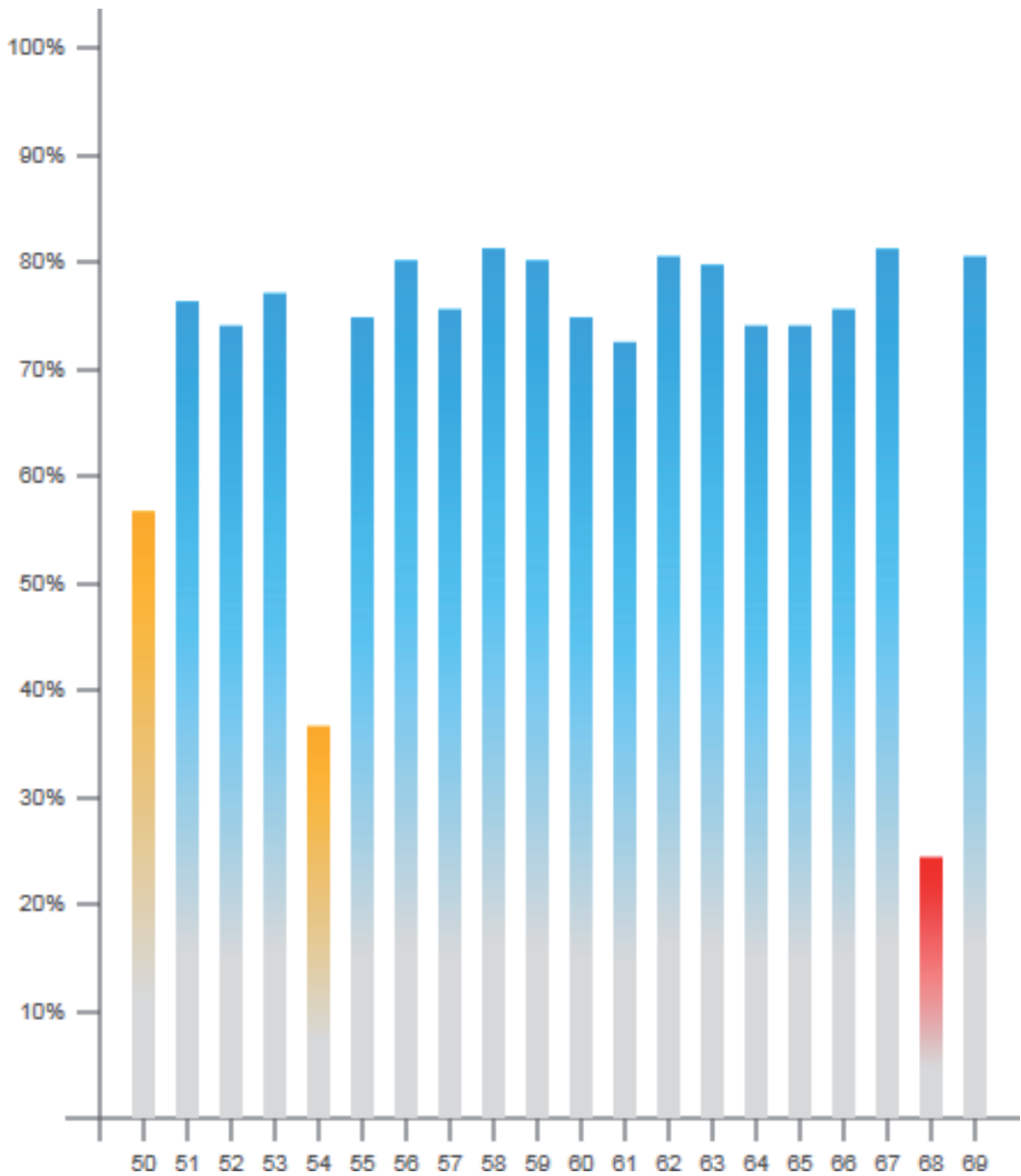

Several inverters in the same photovoltaic system can be compared in the current Comparison View.

The real-time inverter AC power is displayed as a percentage of the power from the solar module connected to the respective inverter (shown in a bar diagram). A bar is displayed for each inverter. The bar color indicates the power range of the inverter:

- Blue: the inverter power corresponds to the average power of all inverters.
- Yellow: the inverter power deviates slightly from the average power of all inverters (50–90% from the average).
- Red: the inverter power deviates significantly from the average power of all inverters or an error has occurred in the inverter (< 50% from the average).

System Overview

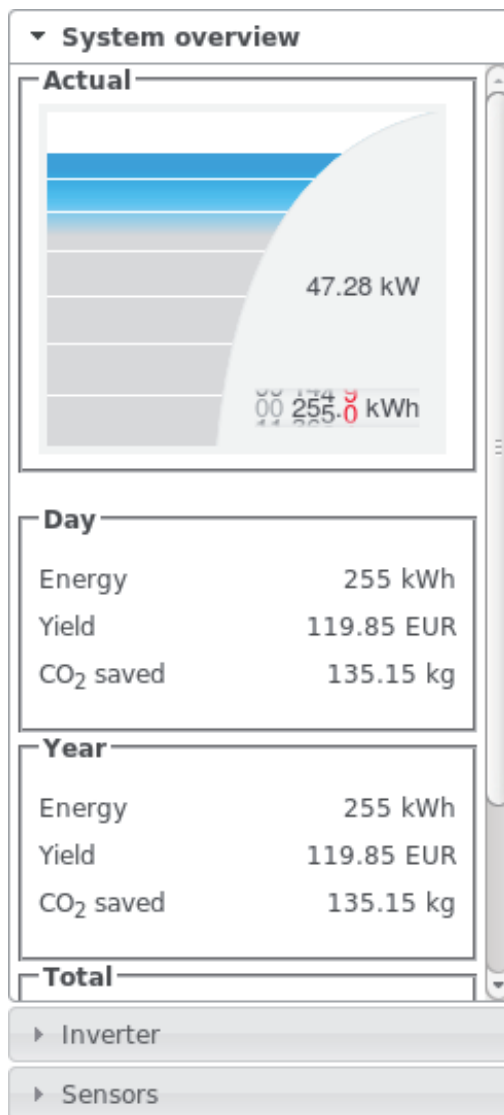

The system overview contains:

- the real-time power data of a photovoltaic system
- the active devices
- the energy generated per day, per year, and in total
- the yield per day, per year, and in total
- CO₂ savings per day, per year, and in total.

Inverter/Sensor View

Inverter View



The Inverter View displays all the inverters present in the system.

*) Clicking on an inverter or the corresponding bar in the Comparison View displays the inverter's real-time data:

Inverter 53	
<i>Fronius IG 30 Dummy</i>	
Operational status	Running
Power	2358 W
Daily energy	8000 Wh
Annual energy	8000 Wh
Total energy	286 kWh
DC voltage	335 V
Direct current	7.4 A
Alternating voltage	229 V
Alternating current	10.3 A
Grid frequency	50.01 Hz

Sensor View

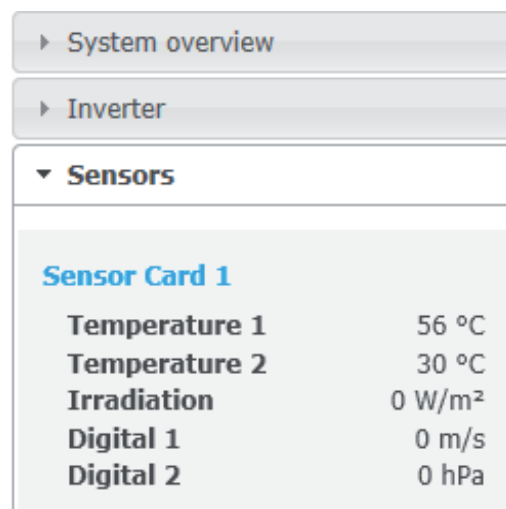





The Sensor View displays all the sensor cards/boxes present in the system.

Fronius Datamanager Services

Services – System Information

System Information

Datalogger ID	240.20817
Circuit board version	2.0A
Software version	3.0.2-1
System time	Apr 15 2013, 11:26:48 CEST
Uptime	0 d, 2 h, 10 min, 11 sec.
User agent	Mozilla/5.0 (X11; Linux x86_64) AppleWebKit/534.34 (KHTML, like Gecko) Qt/4.8.1 Safari/534.34
Gateway	10.5.32.254 (eth0)
DNS server	10.1.1.60, 10.1.1.2
LED states	   
LAN interface	
IP address	10.5.32.132
Subnet mask	255.255.255.0
MAC address	00:03:AC:01:0F:32
WLAN interface	
IP address	192.168.1.170
Subnet mask	255.255.255.0
MAC address	00:06:C6:26:09:E6

Note: This device contains open source software.
 For detailed information about the software being used and the requirements of the corresponding source code, please contact Fronius Tech Support.



- (1) "Data logger Restart" button used to restart Fronius Datamanager
- (2) "Reset to factory settings" button with the following selection options:

all settings except for the network,
 used to reset Fronius Datamanager to factory settings.
 Network settings remain unchanged.

All settings
 used to reset Fronius Datamanager and the network settings to factory settings.

IMPORTANT! Using the "Reset to factory settings" button does not affect the time and date settings. When Fronius Datamanager is reset to factory settings, the time and date settings must be checked.

Services – Network Diagnostics

Network Diagnostics Under Services / Network Diagnostics, "Ping" and "Trace route commands" can be entered.

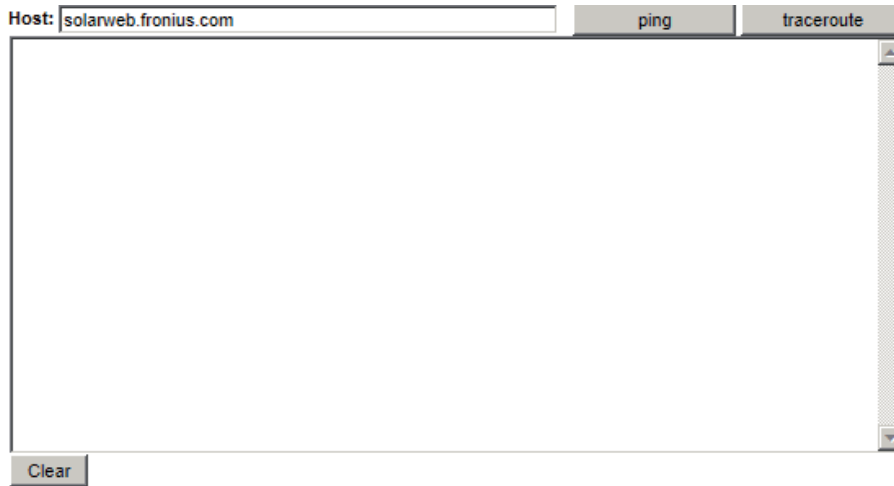

The screenshot shows a web-based interface for network diagnostics. At the top, there is a text input field labeled "Host:" containing the text "solarweb.fronius.com". To the right of this field are two buttons: "ping" and "traceroute". Below the input field is a large, empty rectangular area, likely a scrollable text box for displaying results. At the bottom left of this area is a "Clear" button.

The "Ping command"

is used to determine whether or not a "host" is available and how much time a data transfer will take.

Sending a "Ping" command:

- 1 Enter a host name in the "Host" field
- 2 Click on the "Ping" button
 - Ping command is sent
 - The resulting data is displayed

A "Trace route command"

is used to determine via which intermediate stations the data reaches the "host."

Sending a "Trace route command":

- 1 Enter a host name in the "Host" field
- 2 Click on the "Trace route" button
 - The Trace route command is sent
 - The resulting data is displayed

Services – Firmware Update

General You can update the Fronius Datamanager firmware under Services / Firmware Update. A "firmware update" can be performed via LAN or web.

Automatic Update Search When the "Automatic update search" option (1) is activated, Fronius Datamanager will automatically search for updates once a day. If new updates are available, these are displayed at the bottom of the Fronius Datamanager web interface.

Configuration

Automatic update search ([check now](#)) (1)

Use proxy server for Web update

Proxy server: Port:

User:

Password:

The update process can take several minutes. **The power supply should not be interrupted during this time.** The web interface and the connection to Solar.access/Solar Web will not be available during the update.

The Power LED will blink red during the update. If the update is successful, the LED will stop blinking and remain green, or light up red if there is an error.

Update via Web:
Please make sure that the Datalogger has an active Internet connection.

Carry out

Update via Web

Update via LAN

IP address of your computer: . . .

Manual update search

When the "Automatic update search" function is deactivated, there will be no automatic update search.

1 To search manually for updates, use the "Check now" button (3)

Configuration

Automatic update search ([check now](#)) (3)

Use proxy server for Web update

Proxy server: Port:

User:

Password:

The update process can take several minutes. **The power supply should not be interrupted during this time.** The web interface and the connection to Solar.access/Solar Web will not be available during the update.

The Power LED will blink red during the update. If the update is successful, the LED will stop blinking and remain green, or light up red if there is an error.

Update via Web:

Please make sure that the Datalogger has an active Internet connection.

Carry out

Update via Web

Update via LAN

IP address of your computer: . . .

Firmware update via web

Configuration

Automatic update search ([check now](#))

Use proxy server for Web update

Proxy server: Port:

User:

Password:

The update process can take several minutes. **The power supply should not be interrupted during this time.** The web interface and the connection to Solar.access/Solar Web will not be available during the update.

The Power LED will blink red during the update. If the update is successful, the LED will stop blinking and remain green, or light up red if there is an error.

Update via Web:

Please make sure that the Datalogger has an active Internet connection.

Carry out

Update via Web

Update via LAN

IP address of your computer: . . .

Procedure:

- 1 Use your internet browser to open the Fronius Datamanager web interface
- 2 Open Settings/Firmware update
- 3 Click on the "Run update" button



NOTE! The update process can take several minutes. The power supply to Fronius Datamanager and the internet connection should not be disconnected during this time. The web interface and the connection to Fronius Solar.access or Fronius Solar.web will not be available during the update process.

The update is complete when the "Supply LED" lights up green.

If the connection to the server fails:

- Deactivate the firewall for the duration of the update
- Retry the update

IMPORTANT! If a proxy server is used to connect to the Internet:

- The 'Use proxy server for Web update' selection option must be activated
- The required data must be entered

Firmware update via LAN

Configuration

Automatic update search ([check now](#))

Use proxy server for Web update

Proxy server: Port:

User:

Password:

Carry out

Update via Web

Update via LAN

IP address of your computer: . . .

The update process can take several minutes. **The power supply should not be interrupted during this time.** The web interface and the connection to Solar.access/Solar Web will not be available during the update.

The Power LED will blink red during the update. If the update is successful, the LED will stop blinking and remain green, or light up red if there is an error.

Update via Web:

Please make sure that the Datalogger has an active Internet connection.

Procedure:

- 1 Download the current firmware from the Fronius homepage
- 2 Run the downloaded update file on the PC/laptop

This will start a web server from which Fronius Datamanager will download the required files.

- 3 Use your internet browser to open the Fronius Datamanager web interface
- 4 Open Settings/Firmware update
- 5 Enter the IP address of the PC/laptop
- 6 Click on the "Run update" button



NOTE! The update process can take several minutes. The power supply to Fronius Datamanager and the internet connection should not be disconnected during this time. The web interface and the connection to Fronius Solar.access or Fronius Solar.web will not be available during the update process.

The update is complete when the "Supply LED" lights up green.

If the connection to the server fails:

- Deactivate the firewall for the duration of the update
- Retry the update

Fronius Datamanager Settings

Settings – Passwords

General

Access to Fronius Datamanager is regulated by assigning passwords. 2 different password types are available:

- The user password
- The administrator password

IMPORTANT! New passwords are only activated when the jumper IP address for the Fronius Datamanager plug-in card inside the inverter is reset to the start position.

Passwords

User password

Old password

New password

Re-enter new password

Administrator Password

Old password

New password

Re-enter new password

User password

An assigned user password only gives the user read access to Fronius Datamanager. The user cannot open the "Settings" menu.

Users must enter their username and password every time they connect to Fronius Datamanager.



Username = user

Administrator Password

An assigned administrator password gives the user both read and write access to Fronius Datamanager. The user can then open the "Settings" menu and make any changes as desired.

When assigning an administrator password, the user must enter the username and password in Fronius Datamanager to open the "Settings" menu.

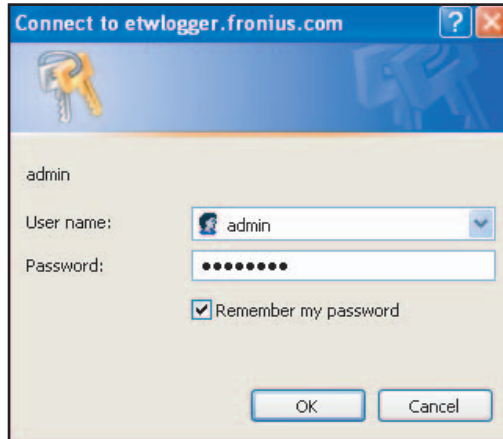

Username = admin

Forgot Your Password?

- 1 Directly connect to Fronius Datamanager:
 - in accordance with chapter "Fronius Datamanager network configuration"
 - in accordance with section "Starting up Fronius Datamanager and opening the Fronius Datamanager web interface"

The Fronius Datamanager web interface will appear (no request for passwords)

- 2 Enter new passwords

Settings – Time/Date

General

The date and time have several tasks in the system.
The time and date are saved for every data record that is logged.



NOTE! You must set the time and date in order to operate Fronius Datamanager.
Data can only be logged if the time and date are set.

Time/Date

Date/Time for Datalogger

: : (1)
 . . (2)
 (3)

Set Date/Time

PC sync (4)
 Automatically adjust for daylight saving changes (5)

Manual

: : (6)
 . . (7)
 (8)

(9)
 (10)

Date/Time for Datalogger

: : (1)
 . . (2)
 (3)

Set Date/Time

PC sync (4)
 Automatically adjust for daylight saving changes (5)

Manual

: : (6)
 . . (7)
 (8)



(9)
 (10)

- (1) Time display
- (2) Date display
- (3) Time zone
- (4) Time/Date setting option:
synchronize to PC/laptop or manual
- (5) Automatically adjust for daylight saving time

IMPORTANT! For the automatic daylight saving time setting, the correct time zone must be selected.

- (6) Time from PC/laptop for PC synchronization setting
Field for manually setting the time
- (7) Date from PC/laptop for PC synchronization setting
- (7a) Calendar icon
- (7b) Calendar (opens when you click on the calendar icon)
- (8) Field for setting the time zone
- (9) "Synchronization" button
- (10) "Cancel" button

Settings – General

General

Yield (1) per kWh

CO₂ factor (2) per kWh

You can enter the charge rate per kWh and the currency for calculating the yield in "Yield" (1). The yield is shown in the current Total View.

You can enter the CO₂ savings per kWh and the unit for calculating the CO₂ savings in CO₂ factor (2). The CO₂ savings are shown in the current Total View.

Settings – Inverter

Views – Inverter

Comparison view

Non-displayed inverters

Select all

>
>>
<
<<

Displayed inverters

Inverter 50 (Fronius IG 30 Dummy) 3000 Wp
Inverter 51 (Fronius IG 30 Dummy) 5000 Wp
Inverter 52 (Fronius IG 30 Dummy) 3000 Wp
Inverter 53 (Fronius IG 30 Dummy) 3000 Wp
Inverter 54 (Fronius IG 30 Dummy) 10000 Wp
Inverter 55 (Fronius IG 30 Dummy) 3000 Wp
Inverter 56 (Fronius IG 30 Dummy) 3000 Wp

Select all

PV Power Wp

The data for the Comparison View is defined in "Inverters":

- 1 Select an inverter to be displayed in the Comparison View
- 2 Enter the respective solar module power for each inverter (the nominal output of the inverter is entered by default)
- 3 Assign PV power to the relevant inverter using the "Accept" button
- 4 Click on "Save."

The settings for the Comparison View are applied.

Settings – Sensor Cards

Sensor Cards

Sensor Card 1 ▾

Measuring Channel	Channel Name
Temperature 1	Temperature 1
Temperature 2	Temperature 2
Insolation	Irradiation
Digital 1	Digital 1
Digital 2	Digital 2
Current	Current

Save Cancel

A specific channel name can be assigned to each sensor value of a Sensor Card in "Sensor Cards" (e.g., Wind Speed)

- 1 Select Sensor Card for which the channel names are to be changed
- 2 Enter the desired channel names
- 3 Click on "Save"

The settings for the Total View are applied.

Settings – Logging

General

At regular intervals, Fronius Datamanager saves the real-time data of all inverters as well as all sensor cards and Fronius sensor boxes integrated into the system. The save interval can be defined in a range of 5 - 30 minutes.

The data can be easily edited, archived, and viewed with a PC or laptop using the "Fronius Solar.access" software.

Logging

Inverter query cycle

Sensor Card query cycle

Memory capacity

Fronius Datamanager has a memory capacity of up to 5 years and 7 months for a photo-voltaic system with one inverter and a save interval of 15 minutes. However, the memory capacity is reduced depending on the number of inverters and/or Fronius sensor cards/boxes that are integrated into the system.

Calculating memory capacity

- 1 Determine logging points for inverters and Fronius sensor cards/boxes

$$\text{Logging points per day} = \frac{\text{Logging duration [min]}}{\text{Save interval [min]}}$$

Logging duration [min]

- For inverter: e.g., 14 hours = 840 minutes
- For Fronius Sensor Card/Fronius Sensor Box: 24 hours = 1440 minutes

- 2 Calculate the total logging points

$$\begin{aligned} \text{Total logging points} &= \\ &= (\text{number of inverters} \times \text{logging points per day}) + (\text{number of Fronius Sensor Cards/Boxes} \times \text{logging points per day}) \end{aligned}$$

- 3 Determine memory sectors per day

$$\text{Memory sectors per day} = \frac{\text{Total logging points}}{114}$$

- 4 Round to whole numbers

- 5 Determine memory capacity

$$\text{Memory capacity [days]} = \frac{2048}{\text{Memory sectors per day}}$$

Calculation example

2 inverters, logging duration = 14 hours (840 minutes)
 1 Fronius Sensor Card, logging duration = 24 hours (1440 minutes)

Save interval = 15 minutes

1. Logging points per day:

$$\text{Inverter logging points} = \frac{840 \text{ min}}{15 \text{ min}} = 56$$

$$\text{Sensor Card logging points} = \frac{1440 \text{ min}}{15 \text{ min}} = 96$$

2. Total logging points:

$$\text{Total logging points} = (2 \times 56) + (1 \times 96) = 208$$

(2 x 56) ... 2 inverters, (1 x 96) ... 1 Sensor Card

3. Memory sectors per day:

$$\text{Memory sectors} = \frac{208}{114} = 1,825$$

4. Rounded:

$$1,825 \quad \Rightarrow \quad 2$$

5. Memory capacity [days]:

$$\text{Memory capacity} = \frac{2048}{2} = 1024 \text{ days} (= 2 \text{ years, } 9 \text{ months, } 18 \text{ days})$$

$$\text{Memory capacity [days]} = \frac{2048}{\text{Memory sectors per day}}$$

Overwriting data when memory is full

When the Fronius Datamanager memory is full, the oldest data will be continually overwritten by the newest data.

"Delete Data" button

All log data saved to Fronius Datamanager is deleted using the "Delete Data" button.

IMPORTANT! The power supply to Fronius Datamanager must not be interrupted during the deletion process.

Settings – Internet Connection

General

The "Internet Settings" menu item is used to determine the type of internet connection (LAN or WiFi).

IMPORTANT! Depending on which internet connection you have selected, a gateway and a DNS server must be entered for the relevant interface.

If, for example, a LAN internet connection was selected, a gateway and a DNS server must be entered for the LAN interface.

In Fronius Datamanager with WiFi, the connection to the Internet can also be made via LAN.

Internet settings



The screenshot shows a dialog box titled "Internet connection" with two radio button options: "via LAN" (which is selected) and "via WLAN". Below the options are two buttons: "Save" and "Cancel".

Settings – LAN

General

The menu item "LAN" is used to determine whether the IP address is to be obtained statically or dynamically.

Obtaining IP address statically (factory setting):

The user enters a fixed IP address for Fronius Datamanager and also manually sets the subnet mask, gateway address, and DNS server address (from the provider).

Obtaining IP address dynamically:

- Fronius Datamanager obtains its IP address from a DHCP server (DHCP = Dynamic Host Configuration Protocol).
- The DHCP server must be configured so that Fronius Datamanager is always assigned the same IP address. You will then always know the IP address at which Fronius Datamanager can be found.
- If the DHCP server supports the "DNS dynamic updates" function, a name can be entered for Fronius Datamanager in the "Host name" field. The connection to Fronius Datamanager can then be established using the name instead of the IP address.

For example: Host name = sample_system, Domain name = fronius.com.

The Fronius Datamanager can be reached via the address "sample_system.fronius.com".

LAN

The screenshot shows a configuration window for LAN settings. At the top, there are two radio buttons: 'static' (unselected) and 'dynamic' (selected). Below this are five text input fields: 'Host name' with the value 'musteranlage', 'IP address' with '10.5.32.255', 'Subnet mask' with '255.255.133.0', 'Gateway' with '10.5.32.254', and 'DNS server' with '10.1.1.60'. At the bottom of the form are two buttons: 'Save' and 'Cancel'.

Settings – WiFi

General

The menu item "WiFi" is used to determine whether the IP address is to be obtained statically or dynamically.

Obtaining IP address statically (factory setting):

The user enters a fixed IP address for Fronius Datamanager and also manually sets the subnet mask, gateway address, and DNS server address (from the provider).

Obtaining IP address dynamically:

- Fronius Datamanager obtains its IP address from a DHCP server (DHCP = Dynamic Host Configuration Protocol).
- The DHCP server must be configured so that Fronius Datamanager is always assigned the same IP address. You will then always know the IP address at which Fronius Datamanager can be found.
- If the DHCP server supports the "DNS dynamic updates" function, a name can be entered for Fronius Datamanager in the "Host name" field. The connection to Fronius Datamanager can then be established using the name instead of the IP address.

For example: Host name = sample_system, Domain name = fronius.com.

The Fronius Datamanager can be reached via the address "sample_system.fronius.com".

WiFi

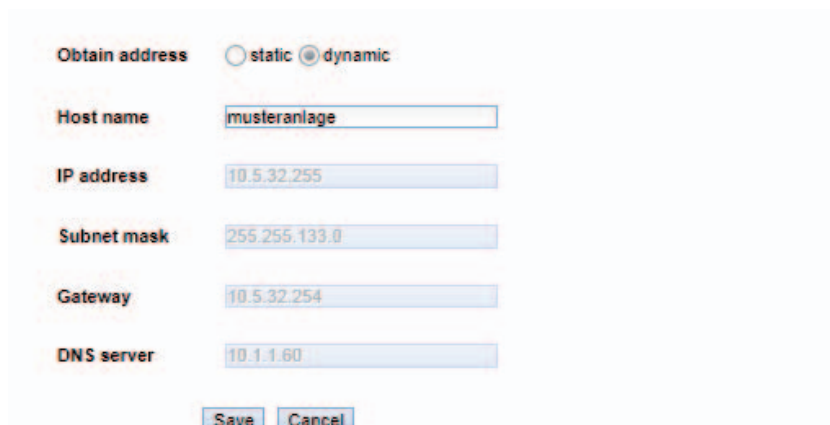

The screenshot shows a configuration window for WiFi settings. At the top, there are two radio buttons: "static" (unselected) and "dynamic" (selected). Below this are several text input fields:

- Host name: musleranlage
- IP address: 10.5.32.255
- Subnet mask: 255.255.133.0
- Gateway: 10.5.32.254
- DNS server: 10.1.1.60

At the bottom of the form, there are two buttons: "Save" and "Cancel".

Settings – WiFi Management

Setting Up Fro-nius Dataman-ager for WiFi Connection

The following steps are required if you decide to use the WiFi network connection.

- 1 Click on "WiFi Management" in the settings and "WiFi Management" appears displaying the available networks (1)

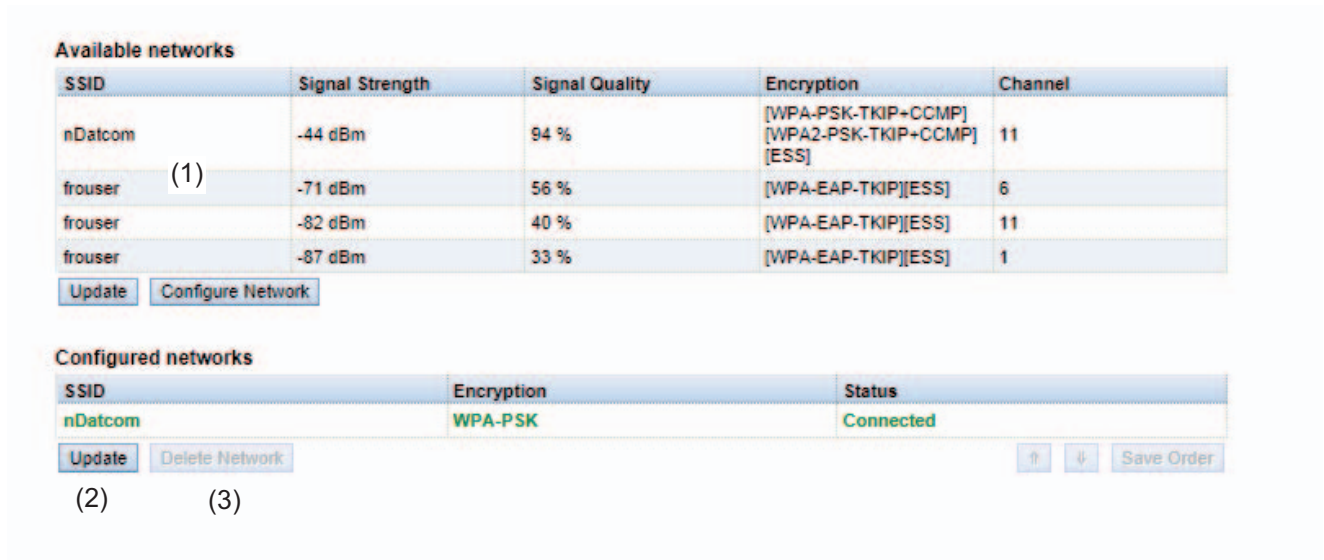

- 2 Click on "Update" (2) to update the networks
- 3 Select a suitable network by clicking on it
- 4 Click on "Network configuration" (3)

"Network configuration" appears

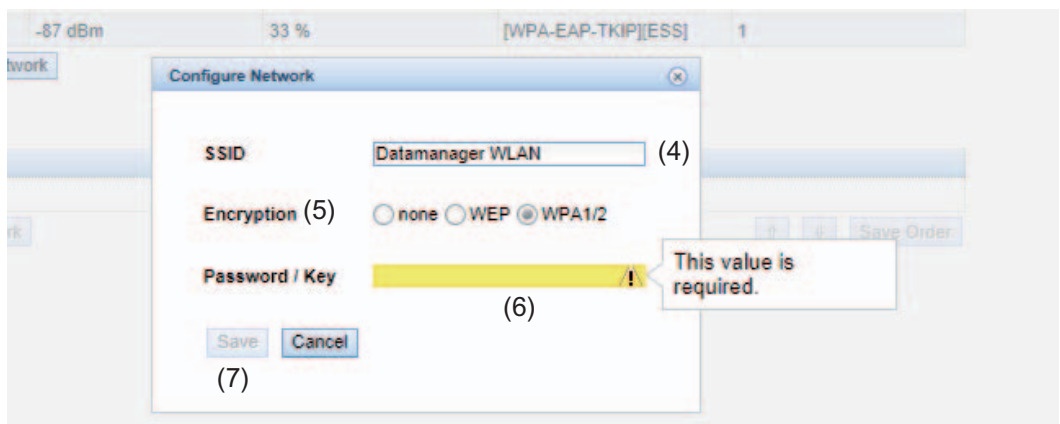

- 5 Enter the SSID network name (4)
- 6 Enter the encryption type (5):
 none = no encryption
 WEP = hexagonal encryption (10–26 hexadecimal numbers)
 WPA1/2 = encryption via pass phrase (8–63 ASCII characters)
- 7 Only if WEP or WPA 1/2 encryption has been selected:
 Enter the corresponding pass phrase/key (6)

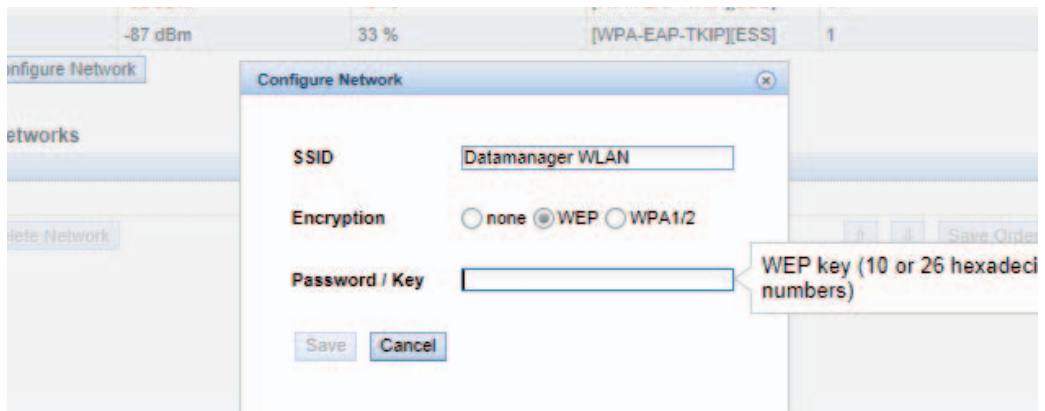
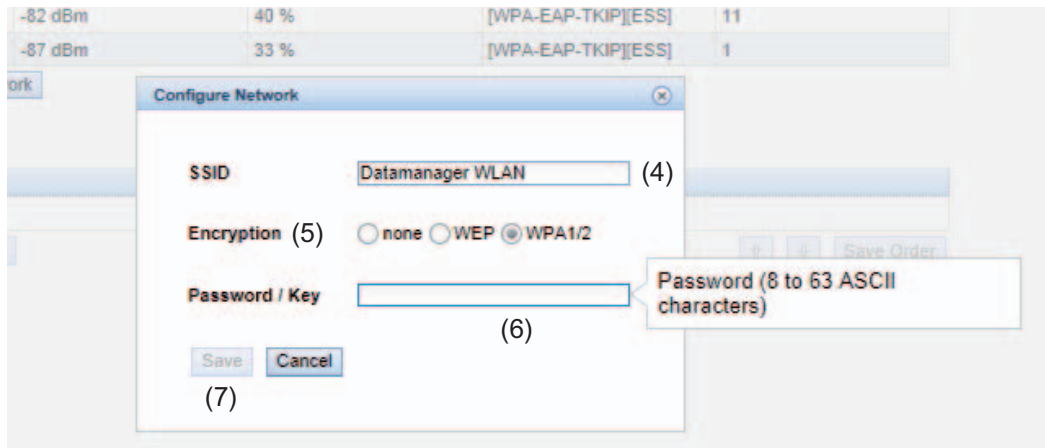

8 Click on "Save" (7)

After the changes have been loaded, the "Changes have been applied" message appears

9 Click on "OK"

and "WiFi-Management" appears

Available networks

SSID	Signal Strength	Signal Quality	Encryption	Channel
nDatcom	-44 dBm	94 %	[WPA-PSK-TKIP-CCMP] [WPA2-PSK-TKIP-CCMP] [ESS]	11
frouser	-71 dBm	56 %	[WPA-EAP-TKIP][ESS]	6
frouser	-82 dBm	40 %	[WPA-EAP-TKIP][ESS]	11
frouser	-87 dBm	33 %	[WPA-EAP-TKIP][ESS]	1

Update Configure Network

Configured networks

SSID	Encryption	Status
nDatcom	WPA-PSK	Connected

Update Delete Network ↑ ↓ Save Order

(8) (9)

You can use the arrow keys (8) and the "Save Order" key (9) to change the sequence of displayed networks.

Settings – Solar.web

General

The Solar.web menu item can be used to make a direct connection between Fronius Data-manager and Fronius Solar.web.

For more information about Fronius Solar.web, see:

- <http://www.fronius.com> – in the Fronius Datamanager operating instructions, section "Connecting to Fronius Datamanager via the Internet and Fronius Solar.web"
- the Fronius Solar.web online help.

Solar.web

Solar.web registration

Send current data to Solar.web
 no yes

Send archive data to Solar.web
 never
 daily

(1) At (2)

On Monday Tuesday Wednesday Thursday Friday Saturday Sunday (3)

Hourly (4)

<input type="checkbox"/> 0:00	<input type="checkbox"/> 3:00	<input checked="" type="checkbox"/> 6:00	<input checked="" type="checkbox"/> 9:00	<input checked="" type="checkbox"/> 12:00	<input checked="" type="checkbox"/> 15:00	<input checked="" type="checkbox"/> 18:00	<input checked="" type="checkbox"/> 21:00	<input type="checkbox"/> Ho
<input type="checkbox"/> 1:00	<input type="checkbox"/> 4:00	<input checked="" type="checkbox"/> 7:00	<input checked="" type="checkbox"/> 10:00	<input checked="" type="checkbox"/> 13:00	<input checked="" type="checkbox"/> 16:00	<input checked="" type="checkbox"/> 19:00	<input type="checkbox"/> 22:00	
<input type="checkbox"/> 2:00	<input type="checkbox"/> 5:00	<input checked="" type="checkbox"/> 8:00	<input checked="" type="checkbox"/> 11:00	<input checked="" type="checkbox"/> 14:00	<input checked="" type="checkbox"/> 17:00	<input checked="" type="checkbox"/> 20:00	<input type="checkbox"/> 23:00	

Daily data transmission to Solar.web

- If the 'daily' selection option is activated, you can select:
- The time of day when data is transmitted (1)
 - Whether data is transmitted each day (2)
 - Whether data is transmitted only on specific days (3)

Hourly data transmission to Solar.web

- If the 'hourly' selection option is activated, you can select:
- The times of day when data is transmitted (4)
 - Whether data is transmitted each day on the hour every hour (5)

Settings – Service Messages

General

Service messages, inverter errors, the Fronius String Control, etc., are sent to Fronius Datamanager and saved. The "Service messages" selection option is used to define how service messages are communicated. They can be communicated via:

- E-mail
- Fax
- SMS

Service messages can be analyzed further using Fronius Solar.web or Fronius Solar.access.

Service Messages

PV System Name (1)

Language (2)

Message to

E-mail recipient: (4) (5) (6) (7)

Fax recipient: (9) (10) (11) (12) (13) (14)

SMS recipient: (16) (17) (18) (19) (20) (21)

(22) (23)

- (1) System name
Included in the service message text;
IMPORTANT The system name is used to identify the photovoltaic system that sent the message. Always enter a system name.
- (2) Selection field for the language in which the service message will be sent
- (3) Message to e-mail recipient
Activate to send service messages to one or more e-mail addresses
- (4) Field for up to a max. of 10 e-mail addresses
Separate e-mail addresses with ";"
- (5) Selection field to determine whether the service message will be sent immediately via e-mail or at a specific time
- (6) Selection field for the time at which a service message will be sent via e-mail
- (7) "Send test e-mail" button
- (8) Message to fax recipient
Activate to send service messages to a fax number

- (9) Field to enter the country code
e.g: +43 = country code for Austria
 - (10) Field to enter the fax area code
 - (11) Field to enter the fax number
 - (12) Field for sending daily
 - (13) Selection field for the time at which a service message is to be sent by fax
 - (14) "Send test fax" button
 - (15) Message to SMS recipient
Activate to send service messages as an SMS to a telephone number
 - (16) Field to enter the country code
e.g: +43 = country code for Austria
 - (17) Field to enter area code
 - (18) Field to enter the telephone number
 - (19) Field for sending daily
 - (20) Selection field for the time at which a service message is to be sent via SMS
 - (21) "Send Test SMS" button
- IMPORTANT!** Check your settings by sending a test message.
- (22) "Save" button
 - (23) "Cancel" button

Settings – Energy Manager

General

The output I/O 1 can be used to control an actuator (e.g., relay, contactor) via the "Energy Manager" function.

A load connected to I/O 1 can thus be controlled by assigning a power feed-dependent switch-on or switch-off point.

Energy Manager

Approved	output	PV power	
(1)	(2)	Operating point ON	Operating point OFF
<input checked="" type="checkbox"/>	I/O 1	<input type="text" value="45000 W"/> (3)	<input type="text" value="44000 W"/> (4)
		<input type="button" value="x Discard"/> (5)	
		<input type="button" value="Save"/> (6)	

- (1) Activating the rule
- (2) Output I/O 1
- (3) Switching threshold ON
For entering an effective power limit, at which the I/O 1 output is activated.
- (4) Switching threshold OFF
For entering an effective power limit, at which the I/O 1 output is deactivated.
- (5) Click "Reject" button
to reject all changes and load the current Fronius Datamanager settings
- (6) Click "Save" button
to save changes

Settings – UC Editor

General

In the "UC Editor" menu item, settings relevant to a utility company are made. An effective power limit in % and/or a power factor limit can be set.

IMPORTANT! Settings in the "UC Editor" menu item may only be made by technicians from the utility company!

UC Editor

(1)	(2)	(3)	(4)	(5)	(6)	(7)
Approved	Input pattern	Effective power	Power factor cosφ	PSC output	Excluded inverters	
	I/O 0 I/O 1 I/O 2 I/O 3 14 15 16 17 18 19			I/O 0		
<input checked="" type="checkbox"/>	■ ■ ■ □ □ □ □ □ □ □ □	<input checked="" type="checkbox"/> 100 %	<input type="checkbox"/> 1 <input type="radio"/> ind <input type="radio"/> cap	<input checked="" type="checkbox"/>	<input type="text"/>	⊖
<input checked="" type="checkbox"/>	■ ■ □ □ □ □ □ □ □ □ □ □	<input checked="" type="checkbox"/> 60 %	<input type="checkbox"/> 1 <input type="radio"/> ind <input type="radio"/> cap	<input checked="" type="checkbox"/>	<input type="text"/>	⊖
<input checked="" type="checkbox"/>	■ ■ □ □ □ □ □ □ □ □ □ □	<input checked="" type="checkbox"/> 30 %	<input type="checkbox"/> 1 <input type="radio"/> ind <input type="radio"/> cap	<input checked="" type="checkbox"/>	<input type="text"/>	⊖
<input checked="" type="checkbox"/>	■ ■ □ □ □ □ □ □ □ □ □ □	<input checked="" type="checkbox"/> 0 %	<input type="checkbox"/> 1 <input type="radio"/> ind <input type="radio"/> cap	<input checked="" type="checkbox"/>	<input type="text"/>	⊖
<input type="checkbox"/>	■ ■ □ □ □ □ □ □ □ □ □ □	<input type="checkbox"/> %	<input type="checkbox"/> <input type="radio"/> ind <input type="radio"/> cap	<input type="checkbox"/>	<input type="text"/>	⊕

... not usable [black]
 ... not considered [grey]
 ... contact open [white]
 ... contact closed [blue]

UC Editor – Factory setting with 100%, 60%, 30%, and 0% effective power. The settings can be changed at any time.

- (1) Activating the rule
- (2) Input Pattern (assignment of individual I/Os)
 - 1 x click = white
 - 2 x clicks = blue
 - 3 x clicks = gray
- (3) Firstly activate effective power then enter the desired effective power as a %
- (4) Firstly activate power factor cos phi then enter the desired power factor and then select ind or cap
 - ind = indicative
 - cap = capacitive
- (5) UC Output (feedback output)
 - When the rule is activated, the I/O 0 output will be activated (e.g., for operating a signal device)

- (6) Excluded inverters
Enter the numbers of inverters here that are to be excluded from the control, separating multiple inverters with commas
- (7) Delete/Add a Rule
+ = add a new rule
- = delete selected rule
- (8) Legend for use of colors
- (9) Click "Reject" button
to reject all changes and load the current Fronius Datamanager settings
- (10) Click "Save" button
to save rules and changes
- (11) Click "Import" button
to import rules in *.fpc format;

the function of the "Import" button is dependent on the browser used, e.g., Firefox and Google Chrome support the function
- (12) Click "Export" button
to save the rules separately in *.fpc format

Connection Example

- (1) Ripple control signal receiver with 3 relays for effective power limitation
- (2) Ripple control signal receiver with 3 relays for power factor limitation
- (3) I/Os on Fronius Datamanager
- (4) Loads (e.g., signal light, signal relay)

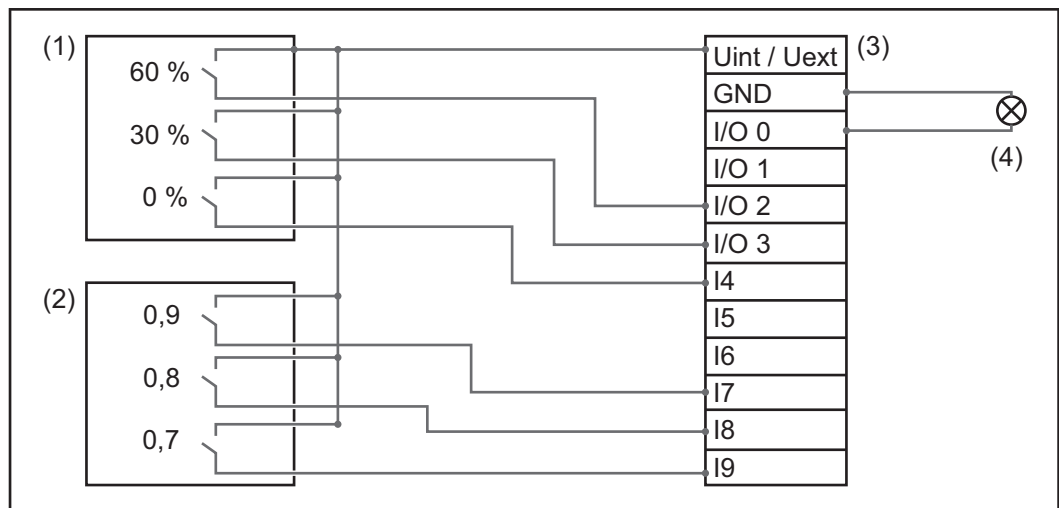

The ripple control signal receiver and the Fronius Datamanager plug are connected to one another using a 4-pin cable in accordance with the connection diagram.

For distances of greater than 10 m between Fronius Datamanager and the ripple control signal receiver, a shielded cable is recommended.

Settings on the UC Editor:

Approved	Input pattern	Effective power	Power factor $\cos\phi$	PSC output	Excluded inverters	
	I/O 0 I/O 1 I/O 2 I/O 3 4 5 6 7 8 9			I/O 0		
↑ <input checked="" type="checkbox"/>	■ ■ □ ■ □ □ ■ ■ ■ ■	<input checked="" type="checkbox"/> 60 %	<input type="checkbox"/> 1 <input type="radio"/> ind <input checked="" type="radio"/> cap	<input checked="" type="checkbox"/>	<input type="text"/>	⊖
(1) <input checked="" type="checkbox"/>	■ ■ □ □ ■ □ ■ ■ ■ ■	<input checked="" type="checkbox"/> 30 %	<input type="checkbox"/> 1 <input type="radio"/> ind <input checked="" type="radio"/> cap	<input checked="" type="checkbox"/>	<input type="text"/>	⊖
↓ <input checked="" type="checkbox"/>	■ ■ □ □ □ ■ ■ ■ ■ ■	<input checked="" type="checkbox"/> 0 %	<input type="checkbox"/> 1 <input type="radio"/> ind <input checked="" type="radio"/> cap	<input checked="" type="checkbox"/>	<input type="text"/>	⊖
↑ <input checked="" type="checkbox"/>	■ ■ ■ ■ ■ ■ ■ ■ □ □	<input type="checkbox"/> 100 %	<input checked="" type="checkbox"/> 0.9 <input type="radio"/> ind <input checked="" type="radio"/> cap	<input type="checkbox"/>	<input type="text"/>	⊖
(2) <input checked="" type="checkbox"/>	■ ■ ■ ■ ■ ■ ■ □ ■ □	<input type="checkbox"/> 100 %	<input checked="" type="checkbox"/> 0.8 <input type="radio"/> ind <input checked="" type="radio"/> cap	<input type="checkbox"/>	<input type="text"/>	⊖
↓ <input checked="" type="checkbox"/>	■ ■ ■ ■ ■ ■ ■ □ □ ■	<input type="checkbox"/> 100 %	<input checked="" type="checkbox"/> 0.7 <input type="radio"/> ind <input checked="" type="radio"/> cap	<input type="checkbox"/>	<input type="text"/>	⊖
<input type="checkbox"/>	■ ■ ■ ■ ■ ■ ■ ■ ■ ■	<input type="checkbox"/> %	<input type="checkbox"/> <input type="radio"/> ind <input checked="" type="radio"/> cap	<input type="checkbox"/>	<input type="text"/>	⊕

... not usable
 ... not considered
 ... contact open
 ... contact closed

Appendix

Technical data

Technical Data

Memory capacity	16 MB
Supply voltage	230 V AC
Energy consumption	typ. 1.4 W (without WiFi) typ. 2.2 W (with WiFi)
Dimensions	132 x 103 x 22 mm 5.2 x 4.1 x 0.9 in.
Ethernet (LAN)	RJ 45, 100 MB
WiFi	IEEE 802.11b/g Client
RS 485 (Fronius Solar Net)	RJ 45
Ambient temperature	-20 – +65°C -4 – +149°F
Solar Net power	approx. 3 W max. 3 DATCOM components *
I/O Connection Specifications	
Voltage level of digital inputs	low = min. 0 V – max. 1.8 V high = min. 3 V – max. 30 V
Input currents of digital inputs	depending on the input voltage; input resistance = 46 kOhm
Switching capacity of digital outputs when supplied by the Datamanager plug-in card	3.2 W, 10.7 V in total for all 4 digital outputs (minus other Solar Net participants)
Switching capacity of digital outputs when supplied by an external power supply with min. 10.7 – max. 24 V DC	1 A, 10.7 – 24 V DC (depending on the external power supply) per digital output
Max. switchable energy of digital outputs	76 mJ (per output)

- * When sufficient power is coming from Fronius Solar Net, the green LED lights up on every DATCOM component.
If the green LED does not light up, the power pack available from Fronius should be inserted into the 12 V power pack connection socket of the DATCOM component.
Check the cable and plug connections if necessary.

Fronius Worldwide - www.fronius.com/addresses

Fronius International GmbH
4600 Wels, Froniusplatz 1, Austria
E-Mail: pv@fronius.com
<http://www.fronius.com>

Fronius USA LLC Solar Electronics Division
6797 Fronius Drive, Portage, IN 46368
E-Mail: pv-us@fronius.com
<http://www.fronius-usa.com>

Under <http://www.fronius.com/addresses> you will find all addresses of our sales branches and partner firms!