

ifm electronic

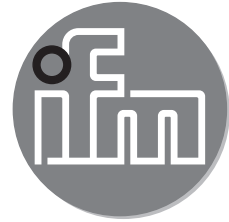

Operating instructions

**efector250**<sup>®</sup>

Robust camera system with  
analogue video output  
O2M20x

UK

706360 / 01 11 / 2015

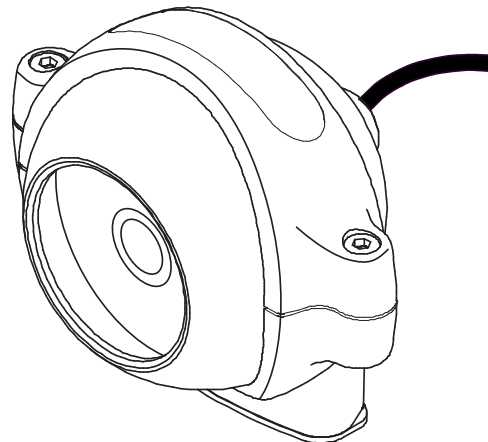

# Contents

1 Preliminary note .....	3
1.1 Symbols used .....	3
1.2 Warning signs used .....	3
2 Safety instructions .....	4
2.1 General .....	4
2.2 Target group .....	4
2.3 Electrical connection.....	4
2.4 Tampering with the device .....	5
3 Functions and features .....	6
3.1 Features at a glance .....	6
4 Installation.....	8
4.1 Mounting accessory.....	8
4.2 Mounting dimensions.....	8
4.3 Installation and adjustment of the camera.....	9
4.4 Installation location .....	10
5 Electrical connection.....	12
5.1 Camera.....	12
5.2 Voltage supply and operational availability .....	13
5.3 Connection and laying of cables.....	13
5.3.1 Connection to the dialogue module .....	14
5.4 Interference due to external influences .....	16
6 Maintenance, repair and disposal.....	16
7 Approvals/standards .....	16

# 1 Preliminary note

## 1.1 Symbols used

- ▶ Instruction
- > Reaction, result
- [...] Designation of keys, buttons or indications
- Cross-reference



Important note

Non-compliance can result in malfunction or interference.



Information

Supplementary note

UK

## 1.2 Warning signs used

### **WARNING**

Warning of serious personal injury.

Death or serious irreversible injuries may result.

### **CAUTION**

Warning of personal injury.

Slight reversible injuries may result.

### **NOTE**

Warning of damage to property.

## **2 Safety instructions**

### **2.1 General**

These instructions are part of the device. They contain texts and figures concerning the correct handling of the device and must be read before installation or use.

Observe the operating instructions. Non-observance of the instructions, operation which is not in accordance with use as prescribed below, wrong installation or incorrect handling can seriously affect the safety of operators and machinery.

### **2.2 Target group**

These instructions are intended for authorised persons according to the EMC and low-voltage directives. The device must only be installed, connected and put into operation by a qualified electrician.

### **2.3 Electrical connection**

Disconnect the unit externally before handling it. If necessary, also disconnect any independently supplied output load circuits.

If the device is not supplied by the mobile on-board system (12/24 V battery operation), it must be ensured that the external voltage is generated and supplied according to the criteria for safety extra-low voltage (SELV) as this voltage is supplied without further measures to the connected controller, the sensors and the actuators.

The wiring of all signals in connection with the SELV circuit of the device must also comply with the SELV criteria (safety extra-low voltage, safe electrical isolation from other electric circuits).

If the supplied SELV voltage is externally grounded (SELV becomes PELV), the responsibility lies with the user and the respective national

installation regulations must be complied with. All statements in this document refer to the device the SELV voltage of which is not grounded. The connection terminals may only be supplied with the signals indicated in the technical data and/or on the device label and only the approved accessories of ifm electronic may be connected.

## **2.4 Tampering with the device**

In case of malfunctions or uncertainties please contact the manufacturer. Any tampering with the device can seriously affect the safety of operators and machinery. This is not permitted and leads to the exclusion of any liability and warranty claims.

### 3 Functions and features

The camera serves for monitoring of areas outside of the field of view in mobile machines and utility vehicles. The connection and the visualisation of the images are made via dialogue modules with graphics capabilities.

The camera works with a PAL25 fps 720H x 576V (active 720 x 480) video signal and permanently provides images to the connected dialogue module.

Applications are for example:

- Rear area or blind spot monitoring for municipal vehicles
- Machine monitoring in construction machinery
- Rear view camera on vehicles

#### 3.1 Features at a glance

Article no.	Angle of aperture	Angle of aperture (integrated mirror function)
O2M200	78°	-
O2M201	-	78° M
O2M202	115°	-
O2M203	-	115° M

- Use and operation with process and dialogue module, e.g. CR1083
- 1/4" 4:3 VGA CMOS image sensor, resolution 680H x 480V
- Lens with fixed focal length
- Light sensitivity < 0.05 lux
- Automatic exposure, automatic white adjustment
- Dynamic range > 80 dB
- Temperature-controlled lens heating

- Resistance to materials in use for transport vehicles such as:

Medium	Concentration
Ammonia	5 %
Isopropanol	5...10 %
Soap water	min. 50 per cent by volume of soap
Alkaline defatting compounds	Concentrations as found for use in high-pressure cleaning devices

- Protection rating IP68 to ISO 20653 (10 m water depth / 30 min)
- Protection rating IP69K to ISO 20653
- IEC 60068-2-52 (cyclic salt spray test)
- Anodised, weather-proof aluminium housing
- Integrated protective circuitry against overvoltage or undervoltage supply, peak voltages, ripple and load dump of the voltage supply
- Nitrogen-filled housing (1 bar pressure)

UK

## 4 Installation

### 4.1 Mounting accessory

- ▶ The unit is supplied with an E2M210 universal mounting clamp. Other mounting accessories are available as alternative.

You can find more information about the available accessories at:

[www.ifm.com](http://www.ifm.com) → New search → O2M200 → Accessories  
or directly

[www.ifm.com](http://www.ifm.com) → New search → e.g. E2M210

### 4.2 Mounting dimensions

The supplied universal mounting clamp has a borehole spacing of 25 mm. Installation is effected via 2 M6 screws.

2 M6 x 20 mm screws, washers and M6 self-locking nuts are supplied with the unit.

Dimensions of the camera, e.g. O2M200:

[www.ifm.com](http://www.ifm.com) → New search → O2M200

Dimensions of the universal mounting clamp:

[www.ifm.com](http://www.ifm.com) → New search → E2M210

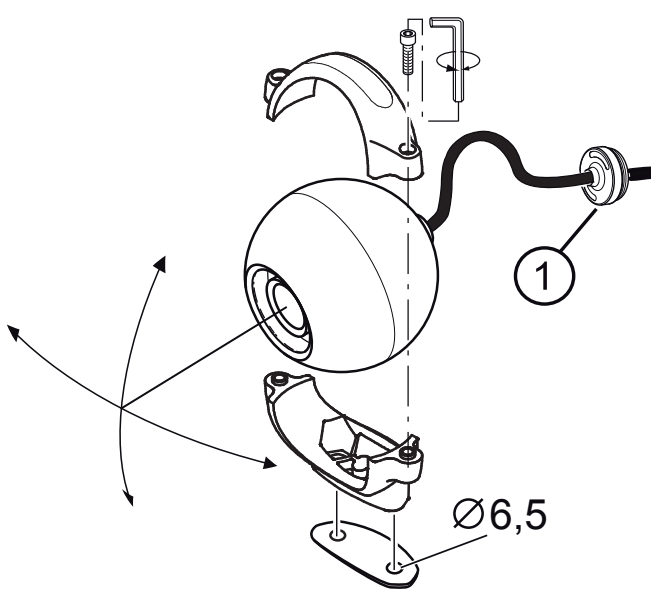

## 4.3 Installation and adjustment of the camera

Installation (example)	
1. Determine a suitable installation location (→ 4.4 Installation location).	
2. Bore the holes for the lower part of the universal mounting clamp. Borehole spacing = 25 cm.	
3. Fix the lower part of the mounting clamp with the M6 screws, washers and self-locking nuts supplied with the unit. Max. tightening torque 11 Nm ( $\pm 1$ Nm).	
4. Insert the camera in the lower part of the clamp. Fix the upper part with the supplied M3 socket head screws.	
5. Align the camera to the area to be monitored. Fix the mounting clamp with a max. tightening torque of 0.8...1 Nm.	
6. Provide for a borehole of $d = 19$ mm for the cable entry in the cabin / terminal chamber. Insert the camera cable and seal the cable entry with the freely positionable rubber grommet (1).	

UK



The minimum bending radius of the camera cable of 50 mm must be observed.

## 4.4 Installation location

► Mount the camera in front of or above the area to be monitored.

The size of the area to be monitored depends on the operating distance:

### Field of view size (2 m operating distance) O2M200 / O2M201

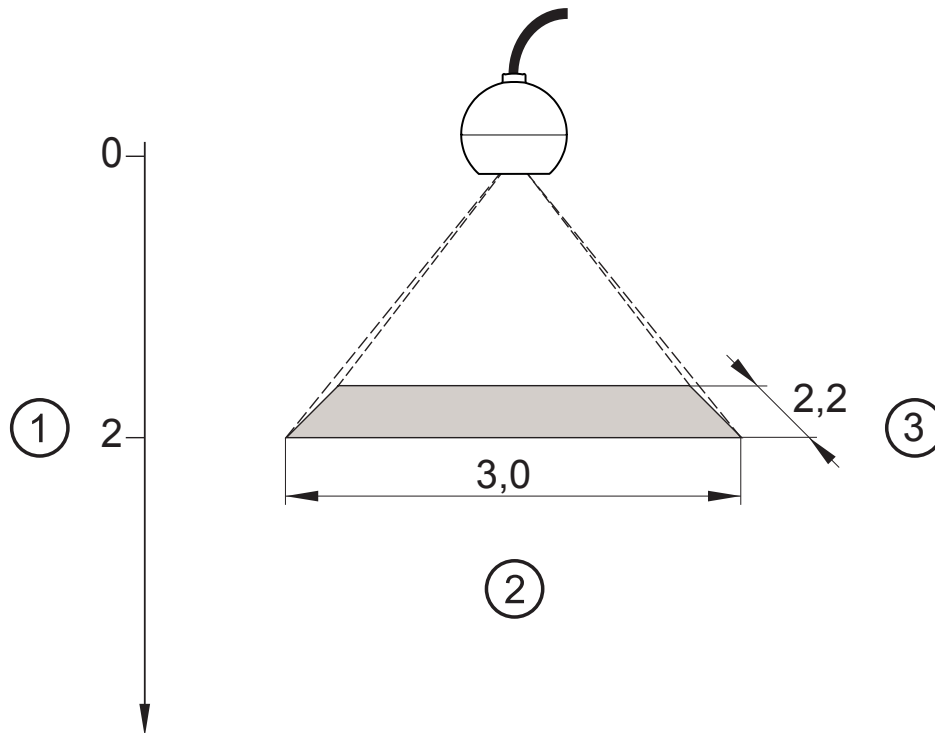

Figure 1: Operating distance and field of view size (78° angle of aperture)

1. Operating distance [m]	2. Width of field of view [m]	3. Height of field of view [m]
1.0	1.5	1.1
2.0	3	2.2
5.0	7.5	5.5



The values indicated in figure 1 are theoretical values and can be different in the application.

## Field of view size (2 m operating distance) O2M202 / O2M203

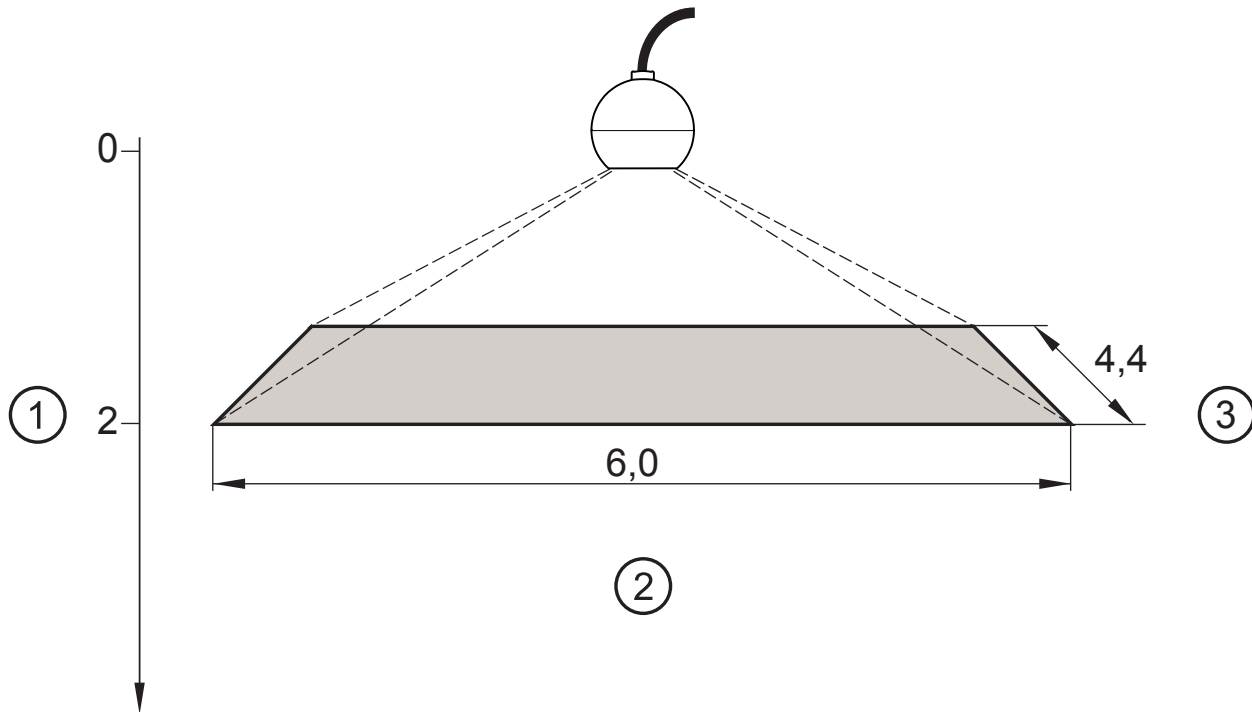

UK

Figure 2: Operating distance and field of view size (115° angle of aperture)

1. Operating distance [m]	2. Width of field of view [m]	3. Height of field of view [m]
1	3	2.2
2	6.0	4.4
5	15	11



The values indicated in figure 2 are theoretical values and can be different in the application.

- To avoid adverse effects on the image detection, avoid installation in heavily polluting areas of the machine (e.g. splashing water, tyre abrasion, etc.).

- ▶ Avoid installation in niches, observe the angle of aperture of the lens.
- ▶ Avoid back light.
- ▶ Do not position lighting elements directly facing the camera lens.
- ▶ Mount the device in such a way that the cables / connectors are connected from below.
- ▶ The connected cables must be provided with a strain relief.
- ▶ Observe the minimum bending radius of 50 mm of the camera cable.

## 5 Electrical connection

### 5.1 Camera

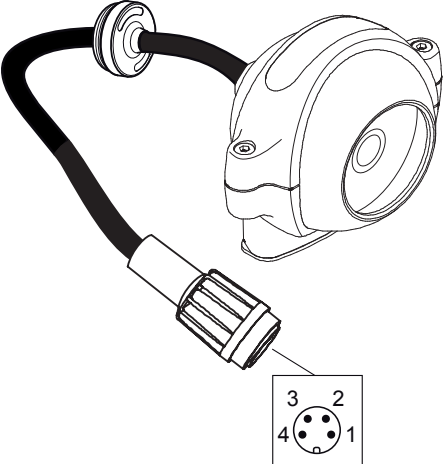
	Signal and supply voltage	
	M16 connector, 4 poles	
	1	Coax cable core (video signal)
	2	Coax screen (video GND)
	3	8...32 V DC
4	0 V	

Information about connection cables at:

[www.ifm.com](http://www.ifm.com) → New search → e.g. O2M200 → Accessories

## 5.2 Voltage supply and operational availability

Power supply	Video signal	Lens heating
< 6 V DC	-	-
> 6 V DC	Yes	-
> 7 V DC	Yes	20 % heating power
> 8 V DC	Yes	40 % heating power
12...33 V DC	Yes	100 % heating power
> 33 V DC	The overvoltage protection switches the camera and the heating element off. When 32 V DC are no longer reached, the overvoltage protection is deactivated.	

UK

## 5.3 Connection and laying of cables

- ▶ Use a screened cable  
[www.ifm.com](http://www.ifm.com) → New search → e.g. O2M200 → Accessories.
- ▶ Use screened connector housings.
- ▶ Do not lay the cable in parallel to live cables.
- ▶ Lay supply and signal cables away from the camera using the shortest possible route.

### 5.3.1 Connection to the dialogue module

- Use adapter cables and, if necessary, connection cables.

Connection principle: O2M20x camera at the dialogue module, e.g. CR1083

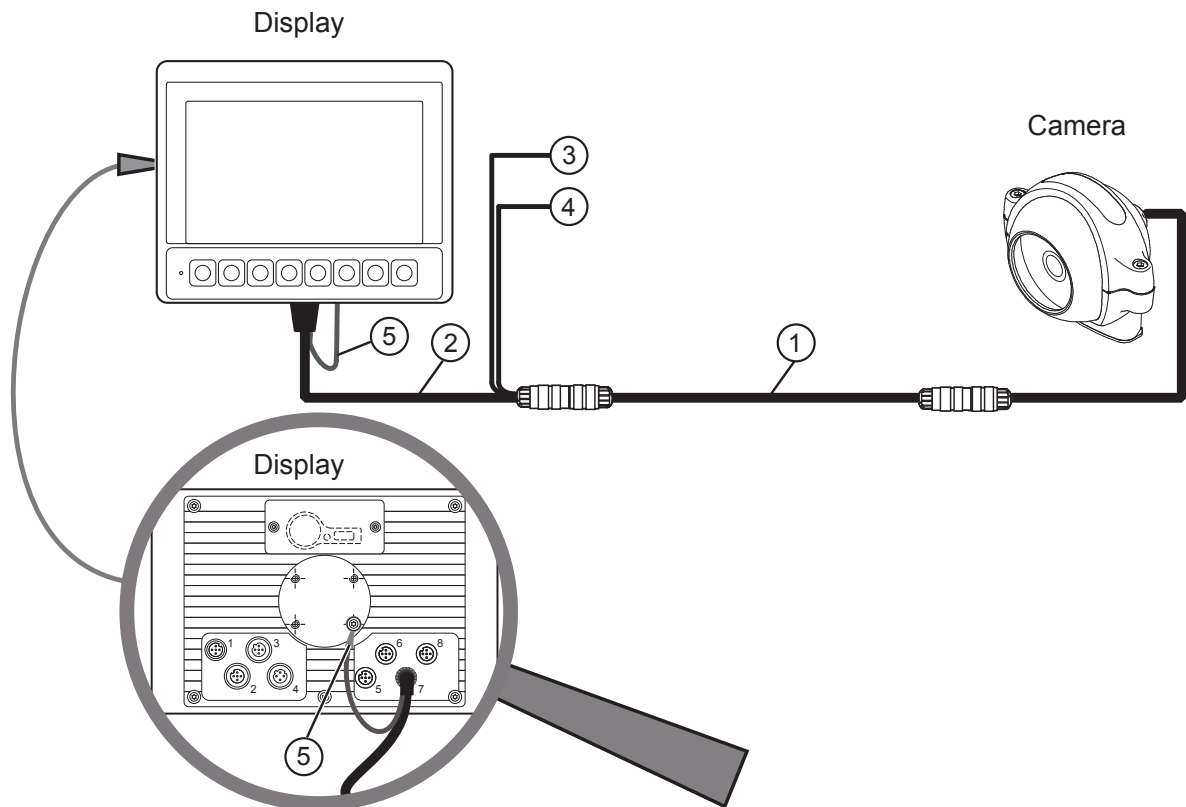

1. M16 connection cable
2. M12 ↔ M16 adapter cable
3. 8...32 V \*)
4. 0 V \*)
5. GND (screen) \*)

\*) Core colours of ifm adapter cables: 3 = RD (red); 4 = BK (black); GND = GY (grey)

You find more information about adapter or connection cables at:  
[www.ifm.com](http://www.ifm.com) → New search → e.g. O2M200 → Accessories

Information about the integration of the camera in a CODESYS application:  
[www.ifm.com](http://www.ifm.com) → New search → e.g. O2M200 → Operating instructions → Short instructions analogue camera at the CR108x dialogue module

Connection principle: Two O2M20x cameras at the dialogue module, e.g. CR1083

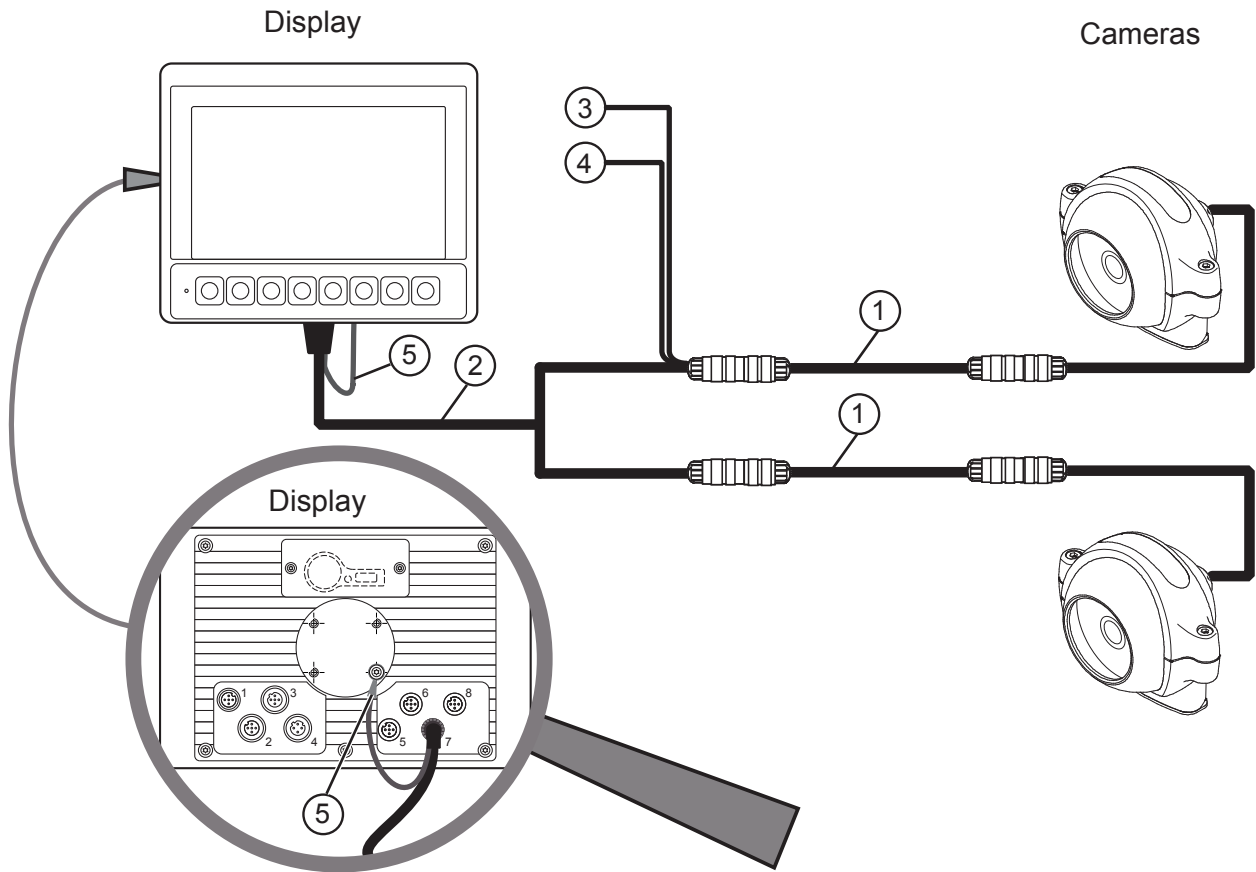

UK

1. M16 connection cable
2. M12 ↔ 2 x M16 Y adapter cable
3. 8...32 V \*)
4. 0 V \*)
5. GND (screen) \*)

\*) Core colours of ifm adapter cables: 3 = RD (red); 4 = BK (black); GND = GY (grey)

You find more information about adapter or connection cables at:  
[www.ifm.com](http://www.ifm.com) → New search → e.g. O2M200 → Accessories

## 5.4 Interference due to external influences



Faulty or insufficient radio interference suppressors in electrical equipment, such as inverters or generators, as well as voltage fluctuations when switching on/off electric loads may lead to problems with the image transmission.

## 6 Maintenance, repair and disposal



Keep the lens window of the camera free from soiling. Soiling may considerably affect the image quality!

- ▶ To clean the lens window, do not use any detergents or solvents which might damage the front glass.
- ▶ Do not open the housing as the device does not contain any components which can be repaired by the user. The device must only be repaired by the manufacturer.
- ▶ Dispose of the device in accordance with the national environmental regulations.

## 7 Approvals/standards

The CE declarations of conformity and approvals can be found at:  
[www.ifm.com](http://www.ifm.com) → New search → e.g. O2M200 → More information →  
Certificates