

Tamrotor

Operating Instructions

Tempest E3, E6

Table of Contents

1. Introduction	1
1.1 Storing the books	1
1.2 Warranty terms	1
1.3 Inquiries	1
2. Safety	2
2.1 Safety during installation and preparations for use	2
2.2 Safety during operation	3
2.3 Safety during maintenance	3
2.4 Safety signs	4
3. Maintenance instructions	5
3.1 Before maintenance	5
3.2 After maintenance	5
3.3 Adding and changing oil	6
3.3.1 Adding oil	6
3.3.2 Changing oil	6
3.4 Replacing the oil filter	7
3.4.1 Removing the oil filter	7
3.4.2 Installing the oil filter	8
3.5 Replacing the air filter	8
3.6 Replacing the oil separator cartridge and the seals of the discharge valve	9
3.7 Testing the pressure relief valve	10
3.8 Oil recommendations	11
3.8.1 Recommended lubricants	11
3.8.2 Oil specifications	11
3.8.3 General guidelines for oil change intervals for mobile use	12
4. Operating principles	13
4.1 Screw unit	13
4.2 Air compressing process	13
5. Technical Appendixes	15

Declaration by the manufacturer

(Directive 2006/42/EC Annex II B)

Manufacturer's Name:

Gardner Denver Oy

Manufacturer's Address:

Etu-Hankkionkatu 9
FIN-33700 Tampere
Finland

The Manufacturer hereby declares that

Tempest T3, T6, T12, T25
with the accessories

is intended to be incorporated into machinery or to be assembled with other machinery to constitute machinery covered by directive as amended

97/23/EC

2006/42/EC

and furthermore declares that the machinery into which it is to be incorporated or of which it is to be a component must be declared to be in conformity with the provisions of Directive

2006/42/EC

and with national implementing legislation, i.e. as a whole, including the machinery referred to in the declaration

Tampere

(Place)

6.9.2016

(Date)

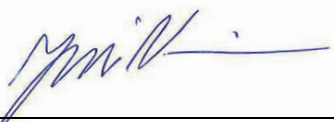

(Signature)

Jussi Nurminen, Managing director

(Name, position in company)

**Gardner Denver Oy
P.O.Box 516
FIN-33101 Tampere
Finland**

Declaration of Incorporation
(Machinery Directive 2006/42/EC, part B, Annex II) of Tempests
Type: Oil-Flooded Screw Compressor (called "Tempest" in the following text)

This tempest was manufactured from: **Gardner Denver Oy**
P.O.Box 516
FIN-33101 Tampere
Finland

The tempest concerned is an integrated oil separation system, type: T3, T6, T12, T25. The air end name plate shows the model, the part number and the serial number of the tempest. This tempest is allowed to compress air and separately specified gases. The maximum allowed operational temperature is 120°C.

The relevant technical documentation is compiled in accordance with part B of Annex VII of the Machinery Directive. All the relevant information of the tempest will be transmitted, in writing, in response to a reasoned request by the national authorities. This shall be done without prejudice to the intellectual property rights of the manufacturer of the tempest.

Documenting unit: **Gardner Denver Oy, Tampere**
Engineering Manager, sustaining: Harri Väänänen

The following essential health and safety requirements of Directive 2006/42/EC, Annex I, are applied and fulfilled:

• Principles of safety integration:

The incorporation of the tempest in the compressor shall be carried out only by qualified personnel. Qualified personnel is, as a general rule, The Gardner Denver Service personnel or the Service personnel authorized by Gardner Denver. The Service personnel should wear appropriate clothing and eye protection during the assembly of the tempest into the compressor. Safety footwear and safety glasses should be compulsory in all workshops. Safety helmets must be worn if there is any risk of falling objects. Gloves are recommended.

The tempest was tested before delivery according to PED 2014/68/EU.

• Materials and product:

The tempest is essentially made of cast iron. Remainder of mineral compressor oil (used in test run) could be inside the tempest.

• Handling:

The packaging of the tempest is done for safe transportation with a minimized risk of damaging during transportation. The installation and commissioning of the tempest should be done within 3 months after delivery. If the tempest should be stored over a long time period, please contact authorized distributor of Gardner Denver for appropriate preservation.

The tempest can only be moved and lifted by using of standard lifting gear. Eye bolts for attaching of lifting tackle have already been installed or are enclosed. Install a minimum of two eye bolts to lift the tempest.

All openings and holes of the tempest are covered and plugged during shipping. After removing covers do not grasp into the tempest! Be careful that no foreign particles or pollution could fall into the tempest during the assembly job or could end into the oil circuit.

• Protection against mechanical hazards

During the installation of the tempest into the compressor normally it's required to disassemble specific protective devices like coupling guard or V-belt guard. These specific protective devices must be reassembled before commissioning of the compressor. Oil must be filled in again according to the user manual. Follow the instructions of the compressor user manual when commissioning the compressor.

• Risk of uncontrolled movements:

During the assembly job the compressor unit must be isolated from the main power supply. When the compressor is DIESEL engine driven, the risk of accidental starting must be eliminated.

• Risk of other hazards:

The essential health and safety requirements, mentioned in the user manual of the compressor (machinery), must be fulfilled when the tempest is incorporated into the compressor and first and foremost when the compressor is commissioned or re-commissioned.

In particular the compressor discharge temperature and the discharge pressure must be monitored with sensors, connected to the compressor control system, tripping ALARM or SHUTDOWN when critical limits are reached.

The tempest must not be put into service until the compressor (final machinery) into which it is to be incorporated has been declared in conformity with the provisions of Directive 2006/42/EC.

Tampere
(Place)

12.1.2017
(Date)



(Signature)

Jussi Nurminen, Managing director
(Name, position in company)

1. Introduction

Gardner Denver wishes you welcome among the users of Gardner Denver screw compressors!

This manual gives you instructions on correct and safe operation and maintenance of your tempest.

Read these and other instructions carefully before taking your product into use. This ensures correct preparations and use from the very beginning.

1.1 Storing the books

All the instructions in this manual have been provided to guarantee a long life and reliable operation of your tempest.

Always keep the manual available near the tempest. Make sure that the tempest is operated and serviced according to the instructions.

1.2 Warranty terms

Get acquainted with the warranty terms of the tempest.

The warranty becomes void if the terms are not observed or if other than original Gardner Denver spare parts are used. Use only the recommended AEON oil types in order to ensure undisturbed operation.

All the service and maintenance duties, which are not covered in this manual should be made only by trained and qualified service personnel authorized by Gardner Denver or its representative.

1.3 Inquiries

When making inquiries concerning your tempest, always quote the complete type specification and the serial number as they are given on the data plate of the tempest.

Gardner Denver reserves the right to change the construction and manuals of the tempest without prior notice.

2. Safety

The general safety instructions concerning the tempest are presented in this chapter.

Read also the safety instructions for transportation, installation, operation and maintenance presented separately in each section of the manual.

Always read the safety instructions before starting to work.



The instructions concerning safety are marked with this symbol.

In addition to these instructions, the local regulations in your country may impose additional requirements that must be observed.

2.1 Safety during installation and preparations for use

The noise level of the compressor, which is presented in the "Technical data" on page 15, is determined according to ISO2151 and ISO3744. The noise level may rise higher if the walls surrounding the installing location reflect sound. Take this into consideration, when choosing the best location for the compressor.

Observe the local regulations concerning the use of ear protectors.

The intake air for the compressor must be clean and cool. **Prevent the used and hot cooling air circulating back to the cooling air intake.** Make sure that foreign objects cannot get into the compressor with the intake air. The intake air must not contain any explosive or inflammable gases or harmful substances.

Do not exceed compressor's rated maximum pressure, capacity or rotation speed. For more details see "Technical data" on page 15.

Use pneumatic hoses that can hold the working pressure. Pay special attention to the hose mountings. The pressure in the hoses must be removed before disconnecting. A whipping hose may cause unpredictable damage.

The pressure vessels in the pressurized air network must be in accordance with the pressure vessel regulations.

Only authorized and qualified personnel should make the electrical connections.

The condensate water contains oil. It should be disposed of according to the local regulations on waste oil.

2.2 Safety during operation

Do not blow pressurized air against the skin.

Use only the recommended AEON oil types. Do not mix different types of oil.

Do not use the compressor in explosive environment.

2.3 Safety during maintenance

While doing maintenance, the compressor must always be stopped and disconnected from the electrical mains connection. The shut-off valve of the pressurized air network must also be closed. Make sure that there is no pressure in the air/oil receiver before starting maintenance.

Use only original Gardner Denver spare parts.

Do not repair the receiver by welding.

All alterations must comply with the pressure vessel regulations PED 97/23/EC.

Do the regular checkups and maintenance of the compressor in order to ensure undisturbed operation.

Maintenance and service operations other than described in this manual must be left to service personnel authorized by Gardner Denver.

2.4 Safety signs



Read User Manual before starting the compressor



Wear ear protectors



Warning: hot surface



Warning: risk of electric shock



Warning: compressor is remotely controlled and may start without warning





Warning: moving parts



Warning: risk of hot exhaust fumes/hot air

General meaning of geometric shapes, safety colors and contrast colors for the safety signs

Geometric shape	Meaning	Safety color	Contrast color	Graphical symbol color
 Circle	Mandatory action	Blue	White	White
 Equilateral triangle	Warning	Yellow	Black	Black

3. Maintenance instructions

Maintenance and service operations other than those described in this manual must be left to service personnel authorized by Gardner Denver.



Always wear protective clothes and gloves during the maintenance.

Use only original Gardner Denver spare parts. The use of other spare parts may cause compressor damage.

3.1 Before maintenance



Before any maintenance operations, switch off the compressor with the main switch and make sure that the compressor cannot be accidentally started.

There are hot surfaces in the compressor immediately after stopping.

1. Stop the compressor and make sure that there is no pressure in the receiver. Wait for 2 minutes after stopping for the blow-down function to empty the receiver.
2. Turn the power off at the main switch and make sure that the compressor cannot be accidentally started.
3. Close the shut-off valve between the compressed air network and the compressor.
4. Open the pressure relief valve's cap with 4 to 5 turns.



The space between the discharge valve and the system shut-off valve stays under pressure when the compressor is stopped and the shut-off valve is closed. Release the pressure for example through a water drain.

3.2 After maintenance

1. Close the pressure relief valve.
2. Open the shut-off valve between the compressed air network and the compressor.
3. Start the compressor.

3.3 Adding and changing oil

Use only recommended AEON oil types. Do not mix different oils.



Oil is hot just after the compressor has stopped.

Do not open the oil filling plug or cooler drain plug if the system is pressurized.

Dispose used oil according to the waste oil regulations.

3.3.1 Adding oil

1. See "Before maintenance" sivulla 5 for precautions.
2. Open the oil filling plug (1) and add new oil until two-thirds, counting from bottom of the oil-checking glass, is reached. **Note! Do not over fill.**
3. Close the oil filling plug (1).
4. Close the pressure relief valve (2) and open the network shut-off valve.

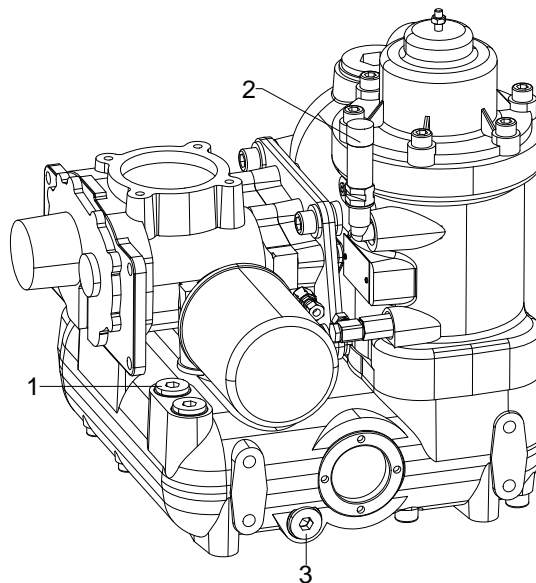

Adding oil

3.3.2 Changing oil

1. Run the compressor until oil temperature is +40...+50°C.
2. See "Before maintenance" sivulla 5 for precautions before starting the work.
3. Open the oil filling plug (1) and the oil drain plug (3). Drain oil into a suitable receiver. Close the oil drain plug (3).

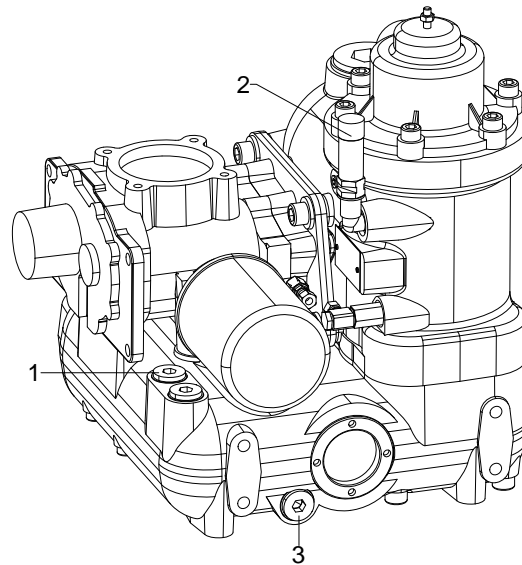

Changing oil

4. Replace the oil filter, see "Replacing the oil filter" sivulla 7.
5. Add new oil and close the oil filling plug (1).
6. Close the pressure relief valve (2) and open the network shut-off valve.
7. (Start the compressor and let it run for 5 minutes. Stop the compressor and wait for awhile so that oil settles and the pressure drops. Add new oil again. Repeat this two times.

3.4 Replacing the oil filter

Allow the compressor to cool down before replacing the oil separator.



Dispose the used oil filter in accordance with local hazardous waste regulations.

Only use original Gardner Denver spare parts. The use of other spare parts may cause compressor damage.

3.4.1 Removing the oil filter

1. See "Before maintenance" sivulla 5 for precautions.
2. The oil filter is installed on the air end. Use a protective cloth, as some oil will drain out when the filter is removed.
3. Remove the filter by rotating it counterclockwise.

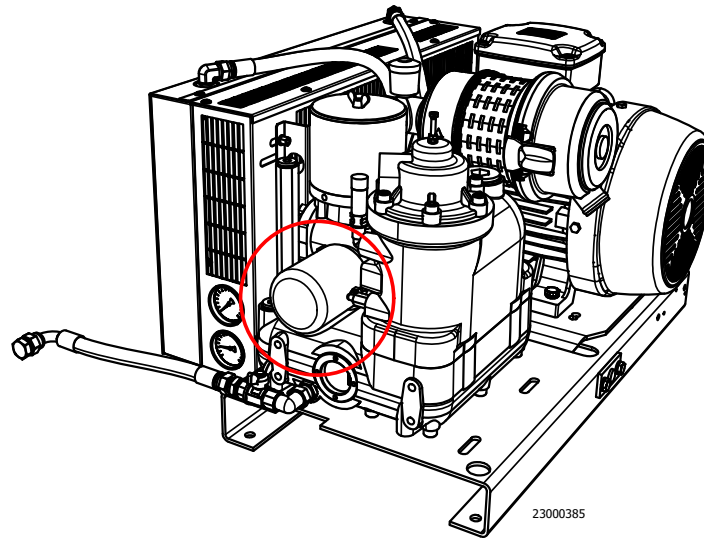

Replacing the oil filter

3.4.2 Installing the oil filter

1. Lubricate the oil filter sealing ring with clean oil.
2. Install the filter by tightening it up clockwise by hand.

3.5 Replacing the air filter

The air filter cannot be cleaned or reused.



Remove the filter with caution. Make sure that particles do not get into the inlet air channel.

Use only original Gardner Denver spare parts. The use of other spare parts may cause compressor damage.

1. See "Before maintenance" sivulla 5 for precautions.
2. Remove the air filter cover (3) and the old filter (2).
3. Clean the air filter housing (1).
4. Install the new air filter (2) and its cover (3) back to their places.

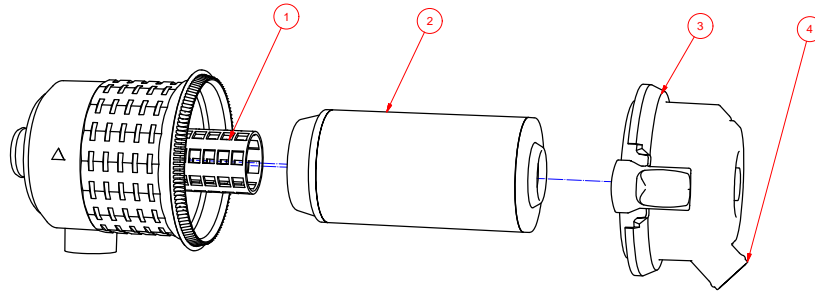

Replacing the air filter



Note! Install particle remover (4) always downwards.

3.6 Replacing the oil separator cartridge and the seals of the discharge valve

Allow the compressor to cool down before the replacement.



Dispose the used oil separation cartridge in accordance with local hazardous waste regulations.

Use only original Gardner Denver spare parts. The use of other spare parts may cause compressor damage.

1. See "Before maintenance" sivulla 5 for precautions before starting to replace the oil separator cartridge. Make sure that there is no pressure in the receiver. **Note! Pressure remains between the discharge valve and the shut-off valve.** Do not open the retaining ring in the bottom of the valve.
2. Remove the body of the discharge valve/the cover of the receiver (1) by opening the screws.
3. Remove the oil separator cartridge (2)
4. Clean the sealing surfaces on the receiver and on the discharge valve (1). Make sure that the inside of the receiver is free of particles.
5. Clean orifices (3) in the hose ends.
6. Replace the filter strainer (4) and clean the oil separator housing.
7. Lubricate the O-ring of the separator cartridge and install new separator cartridge (2) by hand.
8. Replace and lubricate the O-ring (5) between the oil separator housing and the discharge valve.
9. Replace the seals of the discharge valve with a new set if needed.

10. Install the assembled valve back in its place. When assembling the valve, tighten the screws alternately to even tightness.

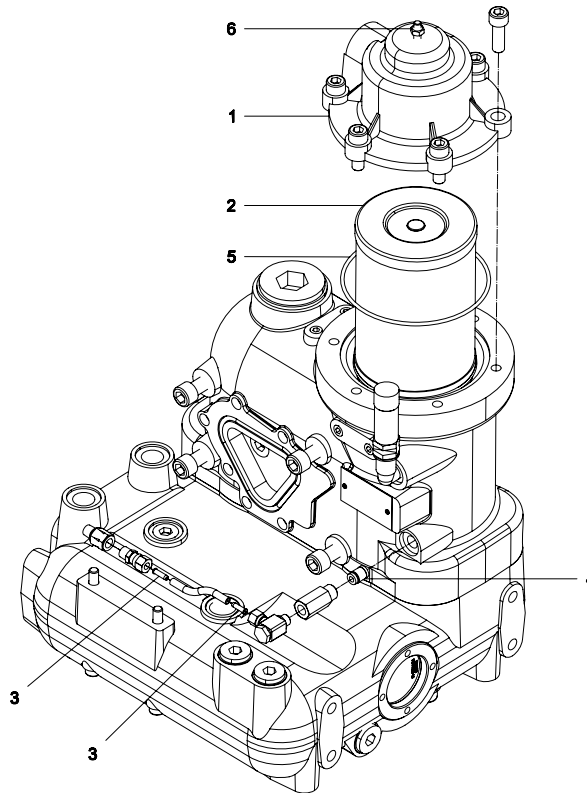

Replacing the oil separator cartridge



There should be about 2 mm clearance between the nut (6) and the top of the discharge valve, when there is no pressure in the receiver or the network. Do not tighten the nut!

3.7 Testing the pressure relief valve



All adjustment and repair operations of the pressure relief valve must be performed by qualified maintenance technicians. All local regulations must be observed.

The compressor must be stopped and secured from automatic restart before attempting this procedure.

The opening pressure of the pressure relief valve must be tested in a separate pressurized air line. The pressure relief valve has been tested at the manufacturer's site before shipping out the compressor. If the valve has been replaced, it needs to be tested for proper operation. This procedure can be performed only by a qualified mechanic.

The operation of the valve can be tested by turning the cap (1) counter-clockwise 1 to 2 turns. Always tighten up the pressure relief valve cap properly to avoid damage caused by vibration.

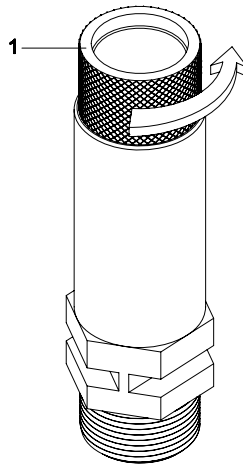

Testing the pressure relief valve

3.8 Oil recommendations

These oil recommendations are for Gardner Denver screw compressors in industrial use.

3.8.1 Recommended lubricants

Gardner Denver compressors are factory filled with AEON lubricants. These lubricants are formulated to the highest quality standards and are factory authorized, tested and approved for use in screw compressors. AEON lubricants are available through your authorized Gardner Denver compressor distributor.

3.8.2 Oil specifications

Recommended lubricants for the compressor:

- Gardner Denver AEON 3000 (mineral oil) factory first fill.
- Gardner Denver AEON 9000 SP (synthetic oil) by request.

Recommended lubricants for the compressor

Package size	AEON 3000* order no.	AEON 9000 SP order no.
3 X 5 litres pack	033 891 44	-
20 litres	033 891 42	897 560 89
209 litres	033 891 43	897 676 89

* first fill

3.8.3 General guidelines for oil change intervals for mobile use

For recommended oil change intervals, please see the table below.

Recommended oil change intervals

Running temperature of the compressor	AEON 3000 oil change interval	AEON 9000 SP oil change interval
70–87°C	500 hours	1 000 hours
88–92°C	500 hours	1 000 hours
≥ 93°C	300 hours	500 hours

Operating temperature of the compressor can be seen in temperature gauge.



Specific AEON lubricants are recommended for use in this equipment. Other lubricants will cause:

- shortened life time of oil filter, oil separating cartridges and oil
- varnishing and blockage of oil circuit
- increased oil consumption
- excessive oil carryover and compressor damage



Do not mix different types of oil

Note! If wrong oil type has been used or oil circuit is varnished, please contact an authorized distributor of Gardner Denver for oil circuit cleaning instructions.

4. Operating principles

4.1 Screw unit

Main components of the screw unit

1. Housing
2. Female rotor
3. Male rotor
4. Discharge flange
5. Shaft seal
6. Bearing cover

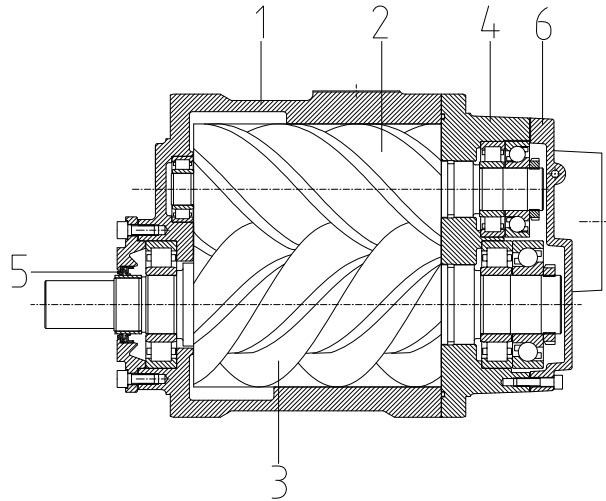

Screw unit

4.2 Air compressing process

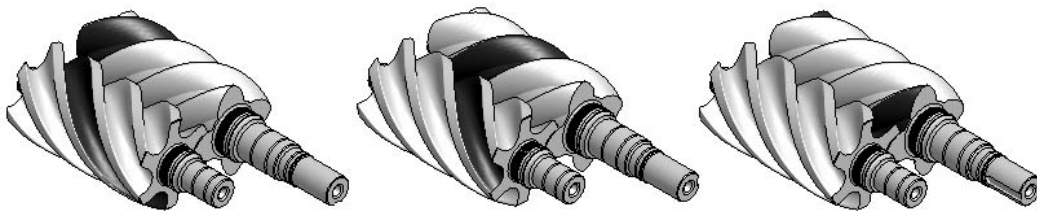

Rotors

In a screw compressor the air is compressed in the air end driven by a motor.

The meshing rotors take air in between the ridges as they pass the inlet opening. When the rotors turn, the connection to the inlet opening closes and the space between the ridges starts to decrease. At the end of the compression phase, the desired pressure has been reached and the connection to the receiver opens.

The air in the air end is cooled by oil that is injected into it. The oil cools also the air end. In addition, the oil lubricates the bearings and seals the clearances between the rotors and the rotor housing.

5. Technical Appendixes

Technical data

Dimensional drawings