INGERSOLL-RAND®

OPERATING, MAINTENANCE, PARTS MANUAL

COMPRESSOR MODELS

P130WJDU

P175WJDU

P185WJDU

Code: A



This manual contains important safety information.

Do not destroy this manual.

This manual must be available to the personnel who operate and maintain this machine.

INGERSOLL-RAND®

AIR COMPRESSORS

Portable Air Compressor Division
P.O. Box 868 - 501 Sanford Ave
Mocksville, N.C. 27028

Doosan purchased Bobcat Company from Ingersoll-Rand Company in 2007. Any reference to Ingersoll-Rand Company or use of trademarks, service marks, logos, or other proprietary identifying marks belonging to Ingersoll-Rand Company in this manual is historical or nominative in nature, and is not meant to suggest a current affiliation between Ingersoll-Rand Company and Doosan Company or the products of either.

QUALITY POLICY

We will supply products and services that consistently meet the requirements of our customers and each other.

CALIFORNIA

Proposition 65 Warning

Diesel engine exhaust and some of its constituents are known to the State of California to cause cancer, birth defects, and other reproductive harm.

Foreword

Machine models represented in this manual may be used in various locations worldwide. Machines sold and shipped into European common market countries requires that the machine display the EC Mark and conform to various directives. In such cases, the design specification of this machine has been certified as complying with EC directives. Any modification to any part is absolutely prohibited and would result in the CE certification and marking being rendered invalid. A declaration of that conformity follows:

Declaration of Conformity

WITH EC DIRECTIVE

98/37/EC

**Ingersoll-Rand Company
Portable Compressor Division
P.O. Box 868
501 Sanford Avenue
Mocksville, North Carolina 27028**

**We
Represented In EC By:**

**Ingersoll-Rand Company Limited
Standard Products Division
Swan Lane
Hindley Green
Wigan WN2 4EZ
United Kingdom**

Declare that, under our sole responsibility for manufacture and supply, the product(s)

HP1300WCU	VHP825WCU	XHP900WCAT	VHP750WCAT	XHP1070CAT
XP1400WCU	HP935WCU	XHP650WCAT	VHP850WCAT	NXP1300WCU
P1600WCU	XP1050WCU	XHP750WCAT	HP900WCAT	
XP900WCU	HP825WCU	XHP825WCAT	XP1000WCAT	

To which this declaration relates, is (are) in conformity with the provisions of the above directives using the following principal standards

**EN1012-1, EN29001, EN202, EN60204-1
PN8NTC2, EN 50081, EN50082**

Issued at Mocksville on 1-1-95



**Ric Lunsford
Manager of Quality Control**

Issued at Hindley Green on 1-1-95



H. Seddon, Q.A. Manager

Nothing contained in this document is intended to extend any promise, warranty or representation, expressed or implied, regarding the Ingersoll-Rand products described herein. Any such warranties or other terms and conditions of sale of products shall be in accordance with the standard terms and conditions of sale for such products, which are available upon request.

This manual contains instructions and technical data to cover all routine operation and scheduled maintenance tasks by operation and maintenance staff. Major overhauls are outside the scope of this manual and should be referred to an authorized Ingersoll-Rand service department.

All components, accessories, pipes and connectors added to the compressed air system should be:

- of good quality, procured from a reputable manufacturer and, wherever possible, be of a type approved by Ingersoll-Rand.
- clearly rated for a pressure at least equal to the machine maximum allowable working pressure.
- compatible with the compressor lubricant/coolant.
- accompanied with instructions for safe installation, operation and maintenance.

Details of approved equipment are available from Ingersoll-Rand Service departments.

The use of repair parts other than those included within the Ingersoll-Rand approved parts list may create hazardous conditions over which Ingersoll-Rand has no control. Therefore, Ingersoll-Rand cannot be held responsible for equipment in which non-approved repair parts are installed.

Ingersoll-Rand reserves the right to make changes and improvements to products without notice and without incurring any obligation to make such changes or add such improvements to products sold previously.

The intended uses of this machine are outlined below and examples of unapproved usage are also given. However, Ingersoll-Rand cannot anticipate every application or work situation that may arise. **If in doubt, consult supervision.**

This machine has been designed and supplied for above ground operation to be used for compression of normal ambient air containing no additional gases, vapors or particles within the ambient temperature range specified in the general data section of this manual.

This machine should not be used:

- A. For direct or indirect human consumption of the compressed air.
- B. Outside the ambient temperature range specified in the general data section of this manual.
- C. When an actual or foreseeable risk of hazardous levels of flammable gases or vapors exists.
- D. With other than Ingersoll-Rand approved components.
- E. With guards, or controls or switches missing or disabled.
- F. For storage or transportation of materials inside or on the enclosure.

This company accepts no responsibility for errors in translation of this manual from the original English version.

TABLE OF CONTENTS

SECTION 1 SAFETY

SECTION 2 WARRANTY/REGISTRATION

SECTION 3 NOISE EMISSION

SECTION 4 GENERAL DATA

SECTION 5 OPERATION

SECTION 6 MAINTENANCE

SECTION 7 LUBRICATION

SECTION 8 TROUBLESHOOTING

SECTION 9 PARTS ORDERING

SECTION 10 PARTS LIST

SECTION 11 OPTIONS PARTS LIST

SECTION 12 ENGINE

SECTION 1- SAFETY

SAFETY PRECAUTIONS

General Information

Ensure that the operator reads and understands the decals and consults the manuals before maintenance or operation.

Ensure that the Operation and Maintenance manual, and the manual holder if equipped, are not removed permanently from the machine.

Ensure that maintenance personnel are adequately trained, competent and have read the manuals.

Make sure that all protective covers are in place and that the canopy/doors are closed during operation.

The specification of this machine is such that the machine is not suitable for use in flammable gas risk areas. If such an application is required then all local regulations, codes of practice and site rules must be observed. To ensure that the machine can operate in a safe and reliable manner, additional equipment such as gas detection, exhaust spark arrestors, and intake (shut-off) valves may be required, dependent on local regulations or the degree of risk involved.

Air discharged from this machine may contain carbon monoxide or other contaminants which will cause serious injury or death. Do not breathe this air.

Compressed air can be dangerous if incorrectly handled. Before doing any work on the unit, ensure that all pressure is vented from the system and that the machine cannot be started accidentally.

Ensure that the machine is operating at the rated pressure and that the rated pressure is known to all relevant personnel.

All air pressure equipment installed in or connected to the machine must have safe working pressure ratings of at least the machine safety valve rating.

If more than one compressor is connected to one common downstream plant, effective check valves and isolation valves must be fitted and controlled by work procedures, so that one machine cannot accidentally be pressurized or over pressurized by another.

Compressed air must not be used for a feed to any form of breathing apparatus or mask.

The discharged air contains a very small percentage of compressor lubricating oil and care should be taken to ensure that downstream equipment is compatible.

If the discharged air is to be ultimately released into a confined space, adequate ventilation must be provided.

When using compressed air, always use appropriate personal protective equipment.

All pressure containing parts, especially flexible hoses and their couplings, must be regularly inspected, be free from defects and be replaced according to the Manual instructions.

Avoid bodily contact with compressed air.

The safety valve located in the separator tank must be checked periodically for correct operation.

Never operate unit without first observing all safety warnings and carefully reading the operation and maintenance manual shipped from the factory with this machine.

Never operate the engine of this machine inside a building without adequate ventilation. Avoid breathing exhaust fumes when working on or near the machine. Do not alter or modify this machine.

A battery contains sulfuric acid and can give off gases which are corrosive and potentially explosive. Avoid contact with skin, eyes and clothing. In case of contact, flush area immediately with water.

Exercise extreme caution when using booster battery. To jump battery, connect ends of one booster cable to the positive (+) terminal of each battery. Connect one end of other cable to the negative (-) terminal of the booster battery and other end to a ground connection away from dead battery (to avoid a spark occurring near any explosive gases that may be present). After starting unit, always disconnect cables in reverse order.

Never operate unit without first observing all safety warnings and carefully reading the operation and maintenance manual shipped from the factory with this machine.

This machine may include such materials as oil, diesel fuel, antifreeze, brake fluid, oil/air filters and batteries which may require proper disposal when performing maintenance and service tasks. Contact local authorities for proper disposal of these materials.

A battery contains sulfuric acid and can give off gases which are corrosive and potentially explosive. Avoid contact with skin, eyes and clothing. In case of contact, flush area immediately with water.

High Pressure Air can cause serious injury or death. Relieve pressure before removing filler plugs/caps, fittings or covers.

Air pressure can remain trapped in air supply line which can result in serious injury or death. Always carefully vent air supply line at tool or vent valve before performing any service.

This machine produces loud noise with the doors open or service valve vented. Extended exposure to loud noise can cause hearing loss. Always wear hearing protection when doors are open or service valve is vented.

Never inspect or service unit without first disconnecting battery cable(s) to prevent accidental starting.

Do not remove the pressure cap from a HOT radiator. Allow radiator to cool down before removing pressure cap.

Do not use petroleum products (solvents or fuels) under high pressure as this can penetrate the skin and result in serious illness. wear eye protection while cleaning unit with compressed air to prevent debris from injuring eye(s).

Disconnected air hoses whip and can cause serious injury or death. Always attach a safety flow restrictor

to each hose at the source of supply or branch line in accordance with OSHA Regulation 29CFR Section 1926.302(b).

Hot pressurized fluid can cause serious burns. Do not open radiator while hot.

Rotating fan blade can cause serious injury. Do not operate without guard in place.

Use care to avoid contacting hot surfaces (engine exhaust manifold and piping, air receiver and air discharge piping, etc.).

Ether is an extremely volatile, highly flammable gas. USE SPARINGLY! Do NOT use ETHER if unit has GLOW Plug starting aid. Engine damage will result.

Never allow the unit to sit stopped with pressure in the receiver-separator system. As a precaution, open the manual blowdown valve.

Never operate unit with guards, covers or screens removed. Keep hands, hair, clothing, tools, blow gun tips, etc. well away from moving parts.

Make sure wheels, tires and tow bar connectors are in safe operating condition and tow bar is properly connected before towing.

Whenever the machine is stopped, air will flow back into the compressor system from devices or systems downstream of the machine unless the service valve is closed. Install a check valve at the machine service valve to prevent reverse flow in the event of an unexpected shutdown when the service valve is open.

Hazardous Substance Precaution

The following substances are used in the manufacture of this machine and may be hazardous to health if used incorrectly. **Precaution:** Avoid ingestion, skin contact and breathing fumes for the following substances: Antifreeze, Compressor Oil, Engine Lubricating Oil, Preservative Grease, Rust Preventative, Diesel Fuel and Battery Electrolyte.

The following substances may be produced during the operation of this machine and may be hazardous to health: Avoid build-up of Engine Exhaust Fumes in confined spaces.

Avoid breathing Exhaust Fumes.

Avoid breathing Brake Lining Dust during maintenance.

SAFETY LABELS

Look for these signs on machines shipped to international markets outside North America, which point out potential hazards to the safety of you and others. Read and understand thoroughly. Heed warnings and follow instructions. If you do not understand, inform you supervisor.



Corrosion risk



Hot Surface

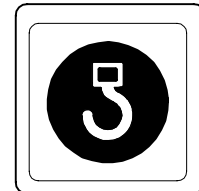

Lifting point



WARNING: Electrical shock risk.

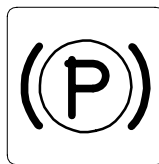

Parking Brake



No open flame

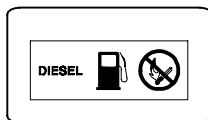

Diesel Fuel.
No open flame.

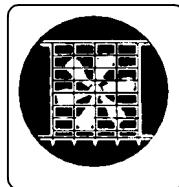

Do not operate the machine
without guard being fitted.



Lifting point



WARNING - Flammable liquid.

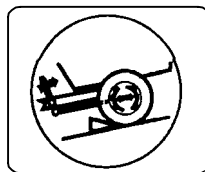

When parking use prop stand,
handbrake and wheel chocks.

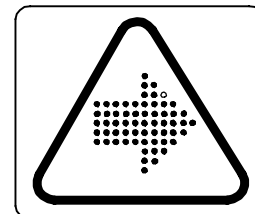

Air/gas flow or Air discharge.



WARNING - Hot and harmful exhaust gas.



Tie down point

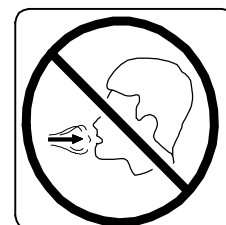

Do not breathe the compressed
air from this machine.



Read the Operation and Maintenance manual before operation or maintenance of this machine is undertaken.

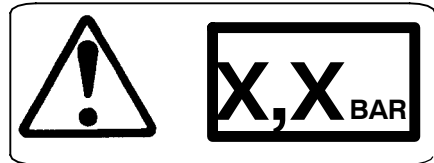

WARNING - Maintain correct tire pressure. (Refer to the *GENERAL INFORMATION* section of this manual).

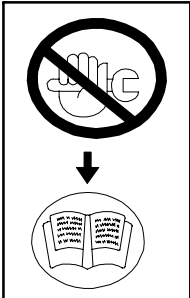

WARNING: Consult the operation and maintenance manual before performing any maintenance.



**Rough Service Designation
Wet Location Operation**

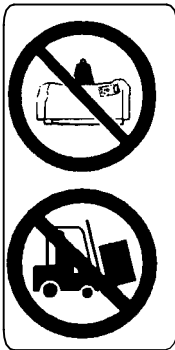

Do not stack

Do not use fork lift truck from this side

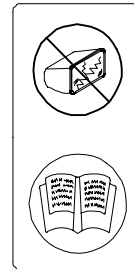

Replace any cracked protective shield.

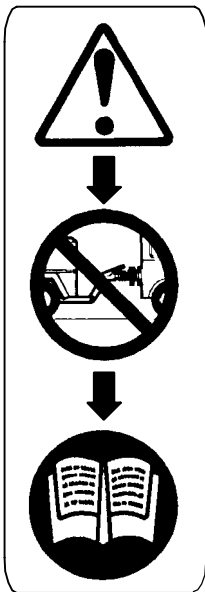

Do not operate with the doors or enclosure open.

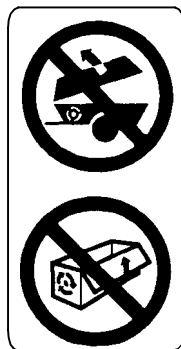

On (power).



Off (power).



Emergency stop.

WARNING - Before connecting the tow bar or when preparing to tow, consult the operation and maintenance manual.

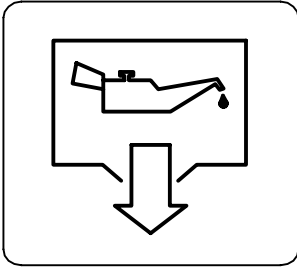

Oil Drain

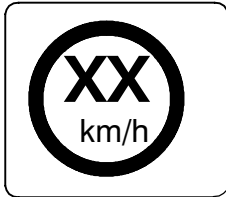

Do not exceed the speed limit.

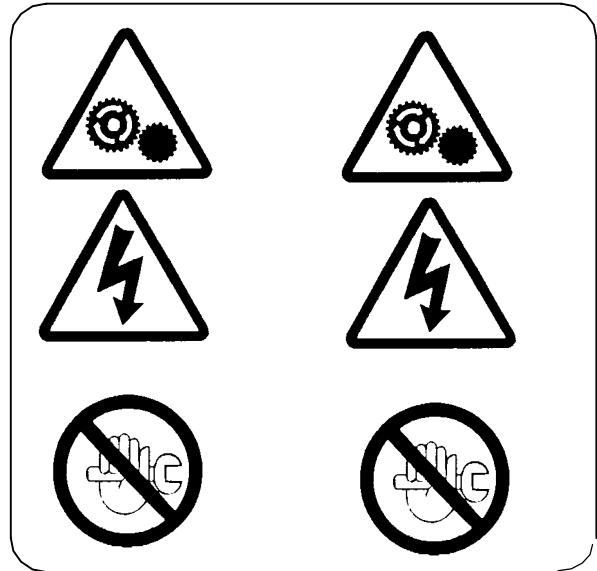

WARNING - Do not undertake any maintenance on this machine until the electrical supply is disconnected and the air pressure is totally relieved.

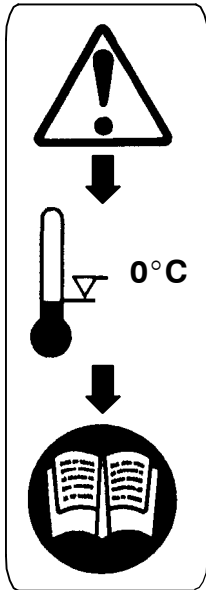

WARNING - For operating temperature below 0°C, consult the operation and maintenance manual.



Read the Operation and Maintenance manual before operation or maintenance of this machine is undertaken



Do not remove the Operating and Maintenance manual and manual holder from this machine.

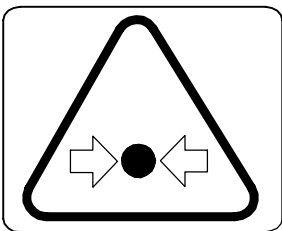

Pressurized vessel.



Use fork lift truck from this side only.

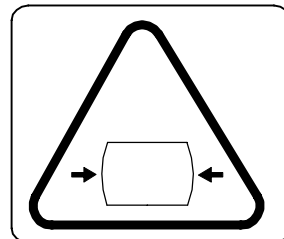

Pressurized component or system.

Look for these signs on machines shipped to markets in North America, which point out potential hazards to the safety of you and others. Read and understand thoroughly. Heed warnings and follow instructions. If you do not understand, inform you supervisor.



(Red Background)

Indicates the presence of a hazard which WILL cause serious injury, death or property damage, if ignored.



(Orange Background)

Indicates the presence of a hazard which CAN cause serious injury, death or property damage, if ignored.



(Yellow Background)

Indicates the presence of a hazard which WILL or can cause injury or property damage, if ignored.

NOTICE

(Blue Background)

Indicates important set-up, operating or maintenance information.

DANGER

Air discharged from this machine can contain carbon monoxide or other contaminants which will cause serious injury or death. Do not breathe this air.

WARNING

Trapped air pressure. Can cause serious injury or death.

Close service valve and operate tool to vent trapped air before performing any service.

WARNING

Hot pressurized fluid. Can cause serious burns. Do not open radiator while hot.

WARNING

High pressure air. Can cause serious injury or death.

Relieve pressure before removing filler plugs/caps, fittings or covers.

WARNING

Improper operation of this equipment. CAN cause serious injury or death.

Read Operator's Manual supplied with this machine before operation or servicing.

WARNING

Modification or alteration of this machine. CAN cause serious injury or death.

Do NOT alter or modify this machine without the express written consent of the manufacturer.

WARNING

Collapsing jack stand. Will cause serious injury.

Insert locking pin completely.

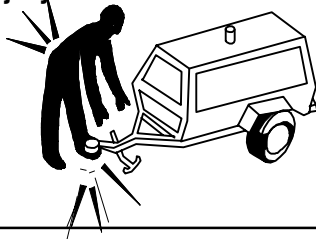

Excessive towing speed. Can cause serious injury or death.

Do NOT exceed 65 mph (104 km/hr)

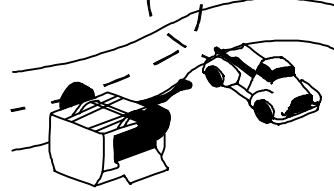

For Highway Towable Units

WARNING

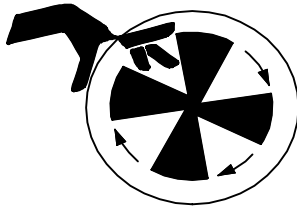

Rotating Fan Blade. CAN cause serious injury.

Do NOT operate with guard removed.

WARNING

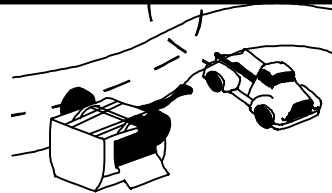

Excessive Towing Speed. CAN cause serious injury or death.

Do NOT Tow on Highway.

Do NOT exceed 20 mph (32 km/h)

For Non-Highway Towable Machines

WARNING

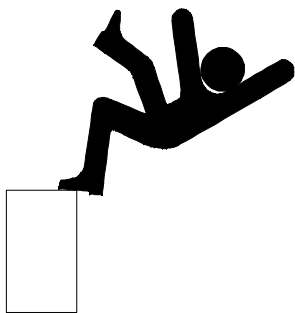

Falling off machine. CAN cause serious injury or death.

Access Lifting Bail from inside machine.

WARNING

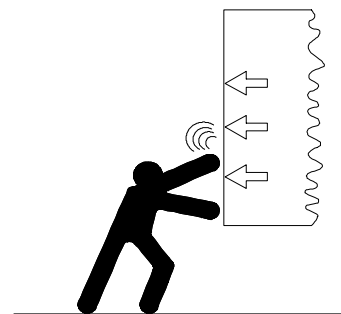

Door under pressure CAN cause serious injury.

Use both hands to open door when machine is running.

WARNING

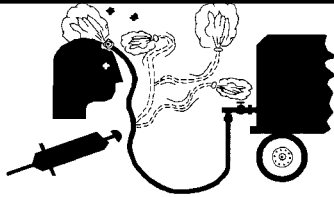

Disconnected Air Hoses Whip. CAN cause serious injury or death.

When using air tools attach safety device (OSHA Valve) at source of air supply for each tool.

WARNING



Combustible Gas. CAN cause serious burns, blindness or death.

Keep sparks and open flames away from batteries.

FREE SAFETY DECALS!

To promote communication of Safety Warnings on products manufactured by the Portable Compressor Division in Mocksville, N.C., Safety Decals are available **free** of charge. Safety decals are identified by the decal heading: **DANGER, WARNING or CAUTION.**

Decal part numbers are on the bottom of each decal and are also listed in the compressor's parts manual. Submit orders for Safety Decals to the Mocksville Parts Service Department. The no charge order should contain only Safety Decals. Help promote product safety! Assure that decals are present on the machines. Replace decals that are not readable.

SECTION 2 - Warranty

Ingersoll-Rand, through its distributor, warrants that each item of equipment manufactured by it and delivered hereunder to the initial user will be free of defects in material and workmanship for a period of three (3) months from initial operation or six (6) months from the date of shipment to the initial user, whichever occurs first.

With respect to the following types of equipment, the warranty period enumerated below will apply in lieu of the foregoing warranty period.

- A. **Aftercoolers** - The earlier of nine (9) months from date of shipment to or six (6) months from start up by initial user.

- B. **Portable Compressors, Portable Generator Sets (GENSET) 8KW, 11KW, 20KVA thru 575KVA, Portable Light Towers and Air Dryers** - The earlier of twelve (12) months from shipment to or the accumulation of 2,000 hours of service by the initial user.
3.5KW thru 7.0KW and 10KW - The earlier of twelve (12) months from shipment to or the accumulation of 2,000 hours of service by the initial user, whichever occurs first. Ingersoll-Rand will provide a new part or repaired part, at its election, in place of any part which is found to be defective in material or workmanship during the period described above. Labor cost to replace the part is the responsibility of the user.

- C. **Portable Compressor Air Ends** - The earlier of twenty-four (24) months from shipment to or the accumulation of 4,000 hours of service by the initial user. For Air Ends, the warranty against defects will include replacement of the complete Air End, provided the original Air End is returned assembled and unopened.

- C.1 **Portable Compressor Airend Limited Optional Warranty** - The earlier of sixty (60) months from shipment to or the accumulation of 10,000 hours of service. The optional warranty is limited to defects in rotors, housings, bearings and gears and provided all the following conditions are met:
 - 1. The original air end is returned assembled and unopened.
 - 2. Continued use of genuine Ingersoll-Rand parts, fluids, oil and filters.
 - 3. Maintenance is performed at prescribed intervals.**Oil-Free airends are fee-based and may require a maintenance agreement. Formal enrollment is required.**

- D. **Genset Generators 8KW, 11KW, 20KVA thru 575KVA** - The earlier of twenty-four (24) months from shipment to or the accumulation of 4,000 hours of service by the initial user.
3.5KW thru 7.0KW and 10KW - The earlier of twelve (12) months from shipment to or the accumulation of 2,000 hours of service.

- E. **Portable Light Tower Generators**- The earlier of twelve (12) months from shipment to or the accumulation of 2,000 hours of service by the initial user. Light Source model only, the earlier of twenty-four (24) months from shipment to or the accumulation of 4,000 hours of service.

- F. **Ingersoll-Rand Engines** - The earlier of twenty-four (24) months from shipment to or the accumulation of 4,000 hours of service.

G. **Ingersoll-Rand Platinum Drive Train Warranty (Optional)** – Platinum drive train pertains to the Ingersoll-Rand Engine and Airend combination. The earlier of sixty (60) months from shipment to, or the accumulation of 10,000 hours of service. The starter, alternator, fuel injection system and all electrical components are excluded from the extended warranty. The airend seal and drive coupling are included in the warranty (airend drive belts are not included). The optional warranty is automatically available when meeting the following conditions:

1. The original airend is returned assembled and unopened.
2. Continued use of genuine Ingersoll-Rand parts, fluids, oil and filters.
3. Maintenance is performed at prescribed intervals.

It is the obligation of the user to provide verification that these conditions have been satisfied when submitting warranty claims.

F. **Spare Parts**– Six (6) months from date of shipment.

Ingersoll-Rand will provide a new part or repaired part, at its election, in place of any part which is found upon its inspection to be defective in material and workmanship during the period prescribed above. Such part will be repaired or replaced without charge to the initial user during normal working hours at the place of business of an Ingersoll-Rand distributor authorized to sell the type of equipment involved or other establishment authorized by Ingersoll-Rand. User must present proof of purchase at the time of exercising warranty.

The above warranties do not apply to failures occurring as a result of abuse; misuse, negligent repairs, corrosion, erosion and normal wear and tear, alterations or modifications made to the product without express written consent of Ingersoll-Rand; or failure to follow the recommended operating practices and maintenance procedures as provided in the product's operating and maintenance publications.

Accessories or equipment furnished by Ingersoll-Rand, but manufactured by others, including, but not limited to, engines, tires, batteries, engine electrical equipment, hydraulic transmissions, carriers, shall carry whatever warranty the manufacturers have conveyed to Ingersoll-Rand and which can be passed on to the initial user.

THIS WARRANTY IS IN LIEU OF ALL OTHER WARRANTIES EXPRESSED OR IMPLIED, (EXCEPT THAT OF TITLE), AND THERE ARE NO WARRANTIES OF MERCHANTABILITY OR OF FITNESS FOR A PARTICULAR PURPOSE.

GENERAL WARRANTY INFORMATION

GENERAL WARRANTY			Extended Coverage
Portable Compressor	Package	1 year/2000 hours	
	Airend	2 years/4000 hours	5 years/10,000 hours Limited warranty, major components (refer to operator's manual).

Portable Genset 8KW, 11KW, 20KVA thru 575KVA	Package	1 year/2000 hours	None
	Generator	2 years/4000 hours	None

Portable Genset 3.5KW thru 7.0KW and 10KW	Package	1 year/2000 hours PARTS ONLY	None
	Generator	1 year/2000 hours PARTS ONLY	None

Light Tower	Package	1 year/2000 hours	
	Generator	1 year/2000 hours	2 years/4000 hours, for Lightsource introduced 8/16/99.

ENGINES			
	Months	Hours	Extended Coverage
Caterpillar	12	No Limit	Available at dealer
Cummins	24	2000	Major components 3 yrs/10,000 hours - available at dealer
John Deere (IN COMPRESSORS)	24	2000	5 yrs/5000 hours using OEM fluids & filters with \$250 deductible. 2 yrs/4000 hours using IR fluids & filters
(IN GENERATORS AS OF 1/1/01)	24	2000	
Deutz	24	2000	Available at dealer
Ingersoll-Rand	24	4000	5 years/10,000 hours when using genuine Ingersoll-Rand fluids and parts. Refer to operator's manual.
Kubota (North America Only)	24	2000	Major components 36 months/3000 hrs - parts only
(Western Europe & Oceania)	24	2000	None
(Central & South America, Asia, Middle East & Africa)	12	1000	None
Mitsubishi	24	2000	2 years/4000 hours using IR fluids and filters
Volvo	24	2000	2 years/4000 hours using IR fluids and filters
Honda	12	unlimited	None
Vanguard	24	unlimited	None

PARTS			
	Months	Hours	Coverage
Ingersoll-Rand	6	No Limit	Parts Only

AIREND EXCHANGE			
	Months	Hours	Extended Coverage
Airend	12	2000 hours	2 years/4000 hours - available from IR.

Note: Actual warranty times may change. Consult the manufacturer's warranty policy as shipped with each new product.

Extended Limited Airend Warranty

Ingersoll-Rand Portable Compressor Division is pleased to announce the availability of extended limited airend warranty. Announcement of the extended warranty coincides with the introduction of PRO•TEC™ Compressor Fluid. PRO•TEC™ Compressor Fluid is an amber colored fluid specially formulated for Portable Compressors and is being provided as the factory filled fluid for all machines except 1 XHP650/900/1070 models.

All machines have the standard airend warranty - *The earlier of 24 months from shipment to, or the accumulation of 4000 hours of service.*

The warranty against defects will include replacement of the complete airend, provided the original airend is returned assembled and unopened.

The optional limited warranty is the earlier of 60 months from shipment to, or the accumulation of 10,000 hours of service. The optional warranty is limited to defects in major components (rotors, housings, gears, bearings), and is automatically available when the following three conditions are met:

1. The original airend is returned assembled and unopened.
2. Submissions of proof that Ingersoll-Rand fluid, filters and separators have been used. Refer to the Operation and Parts manual for the correct fluids, filters and separator elements required.
3. Submission of proof that maintenance intervals have been followed.

WARRANTY	TIME	*BARE AIREND	** AIREND COMPONENTS
STANDARD	2 yrs/4000 hrs	100% parts and labor	100% parts and labor
OPTIONAL	5 yrs/10,000 hrs	100% parts and labor	0%

* Bare Airend - pertains to major airend parts (rotors, housings, gears and bearings).

** Airend Components - pertains to auxiliary attachments to the bare airend (drive coupling, seals, pumps, valves, tubes, hoses, fittings and filter housing).

PRO•TEC™ and XHP505 Compressor Fluids are available from the Mocksville Product Support department by calling 1-800-633-5206.

¹ XHP650/900/1070 will continue to use XHP505 and will have the extended warranty when above conditions are met.

WARRANTY REGISTRATION

Complete Machine Registration

Machines shipped to locations within the United States do not require a warranty registration unless the machine status changes (i.e. change of ownership).

Machines shipped outside the United States require notification be made to initiate the machine warranty.

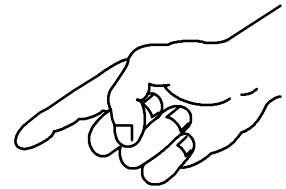

Fill out the Warranty Registration Form in this section, keep a copy for your records and mail form to:

Ingersoll-Rand Company
Portable Compressor Division
P.O. Box 868
Mocksville, North Carolina 27028
Attn: Warranty Department

Note: Completion of this form validates the warranty.

<u>Selling Distributor</u>	<u>Servicing Distributor</u>	WARRANTY REGISTRATION
Name _____	Name _____	Owner/User Name _____
Address _____	Address _____	Address _____
City _____	City _____	City _____
County _____	County _____	County _____
State _____	State _____	State _____
Zip Code _____	Zip Code _____	Zip Code _____
Telephone _____	Telephone _____	Telephone _____

Complete the Applicable Blocks
Owner/User Type of Business (check one only)

<input type="checkbox"/> Construction-Heavy (highway, excavation, etc.)	<input type="checkbox"/> Asphalt Contractor	<input type="checkbox"/> Coal Mining	<input type="checkbox"/> Other Mining
<input type="checkbox"/> Construction-Light (carpentry, plumbing, pools, mason, etc.)	<input type="checkbox"/> Government (municipal, state, county, etc.)	<input type="checkbox"/> Quarry	<input type="checkbox"/> Shallow Oil & Gas
<input type="checkbox"/> Rental (rental center, rental fleet, etc.)	<input type="checkbox"/> Building Contractor	<input type="checkbox"/> Waterwell	<input type="checkbox"/> Utility Company (gas, electric, water, etc.)
<input type="checkbox"/> Industrial (plant use)	<input type="checkbox"/> Other specify _____	<input type="checkbox"/> Exploration	<input type="checkbox"/> Utility Contractor

Model	Unit S/N	Engine S/N	Date Delivered
Unit-Hours	Airend S/N	Truck S/N	Truck Engine S/N

SERVICING DISTRIBUTOR/USER ACKNOWLEDGEMENT

1. The Purchaser has been instructed and/or has read the manual and understands proper preventative maintenance, general operation and safety precautions.
2. The warranty and limitation of liability has been reviewed and understood by the owner/user.
3. In the event that this unit is to be used within a nuclear facility, the owner/user shall notify Ingersoll-Rand of such use so that Ingersoll-Rand may arrange for appropriate nuclear liability protection from the owner-licensee of the facility.
4. Ingersoll-Rand reserves the right to make design changes or modifications of Ingersoll-Rand products at anytime without incurring any obligation to make similar changes or modifications on previously sold units.

Attention: Warranty Department

**Ingersoll-Rand Company
Portable Compressor Division
P.O. Box 868
Mocksville, North Carolina 27028**

fold

SECTION 3 - NOISE EMISSION

This section pertains only to machines distributed within the United States.

WARNING

TAMPERING WITH NOISE CONTROL SYSTEM PROHIBITED

Federal law prohibits the following acts or the causing thereof:

(1) The removal or rendering inoperative by any persons, other than for purposes of maintenance, repair, or replacement, of any device or element of design incorporated into any new compressor for the purpose of noise control prior to its sale or delivery to the ultimate purchaser or while it is in use; or (2) the use of the compressor after such device or element of design has been removed or rendered inoperative by any person.

Among those acts included in the prohibition against tampering are these:

4. Removal or rendering inoperative any of the following:
 - a. the engine exhaust system or parts thereof
 - b. the air intake system or parts thereof
 - c. enclosure or parts thereof
5. Removal of any of the following:
 - a. fan shroud
 - b. vibration mounts
 - c. sound absorption material
6. Operation of the compressor with any of the enclosure doors open.

Compressor Noise Emission Control Information

A. The removal or rendering inoperative, other than for the purpose of maintenance, repair, or replacement of any noise control device or element of design incorporated into this compressor in compliance with the noise control act;

B. The use of this compressor after such device or element of design has been removed or rendered inoperative.

Note: the above information applies only to units that are built in compliance with the U.S. Environmental Protection Agency.

Ingersoll-Rand Company reserves the right to make changes or add improvements without notice and without incurring any obligation to make such changes or add such improvements to products sold previously.

The Purchaser is urged to include the above provisions in any agreement for any resale of this compressor.



NOISE EMISSION CONTROL MAINTENANCE LOG

COMPRESSOR MODEL _____
SERIAL NO. _____
USER UNIT NO. _____

UNIT IDENTIFICATION Engine Make & Model: _____ Serial No.: _____ Purchaser or Owner: _____ Address: _____	DEALER OR DISTRIBUTOR FROM WHOM PURCHASED: _____ _____ Date Purchased: _____
--	--

The Noise Control Act of 1972 (86 Stat. 1234) prohibits tampering with the noise control system of any compressor manufactured and sold under the above regulations, specifically the following acts or the causing thereof:

(1) the removal or rendering inoperative by any persons, other than for purposes of maintenance, repair, or replacement, of any device or element of design incorporated into new compressor for the purpose of noise control prior to its sale or delivery to the ultimate purchaser or while it is in use; or (2) the use of the compressor after such device or element of design has been removed or rendered inoperative by any person.

NOISE EMISSION WARRANTY

The manufacturer warrants to the ultimate purchaser and each subsequent purchaser that this air compressor was designed, built and equipped to conform at the time of sale to the first retail purchaser, with all applicable U.S. EPA Noise Control Regulations.

This warranty is not limited to any particular part, component, or system of the air compressor. Defects in the design, assembly or in any part, component, or system of the compressor which, at the time of sale to the first retail purchaser, caused noise emissions to exceed Federal Standards are covered by this warranty for the life of the air compressor.

INTRODUCTION

The unit for which this Maintenance Log is provided conforms to U.S. E.P.A. Regulations for Noise Emissions, applicable to Portable Air Compressors.

The purpose of this book is to provide (1) the Maintenance Performance Schedule for all required noise emission controls and (2) space so that the purchaser or owner can record what maintenance was done, by whom, where and when. The Maintenance Schedule and detailed instructions on the maintenance items are given on following page.

MAINTENANCE SCHEDULE

ITEM	AREA	PERIOD
A.	Compressed Air Leaks	As Detected
B.	Safety and Control Systems	As Detected
C.	Acoustic Materials	Daily
D.	Fasteners	100 hours
E.	Enclosure Panels	100 hours
F.	Air Intake & Engine Exhaust	100 hours
G.	Cooling Systems	250 hours
H.	Isolation Mounts	250 hours
I.	Engine Operation	See Operator's Manual
J.	Fuels & Lubricants	See Operator's Manual

A. Compressed Air Leaks

Correct all compressed air leaks during the first shut-down period after discovery. If severe enough to cause serious noise problems and efficiency loss, shut down immediately and correct the leak(s).

B. Safety and Control Systems

Repair or replace all safety and control systems or circuits as malfunction occurs. No compressor should be operated with either system bypassed, disabled, or nonfunctional.

C. Acoustic Materials

In daily inspections, observe these materials. Maintain all acoustic material as nearly as possible in its original condition. Repair or replace all sections that have: 1) sustained damage, 2) have partially separated from panels to which they were attached, 3) are missing, or have otherwise deteriorated due to severe operating or storage conditions.

D. Fasteners

All fasteners such as hinges, nuts, bolts, clamps, screws, rivets, and latches should be inspected for looseness after each 100 hours of operation. They should be retightened, repaired, or if missing, replaced immediately to prevent subsequent damage and noise emission increase.

E. Enclosure Panels

Enclosure panels should also be inspected at 100 hour operational intervals. All panels that are warped, punctured, torn, or otherwise deformed, such that their noise containment function is reduced, should be repaired or replaced before the next operation interval. Doors, access panels, and hatch closures especially, should be checked and adjusted at this time to insure continuous seating between gasket or acoustic material and the mating frame.

F. Air Intake and Engine Exhaust

Engine and compressor air intake and engine exhaust systems should be inspected after each 100 hours of operation for loose, damaged, or deteriorated components. Repairs or replacements should be made before the next period of use.

G. Cooling Systems

All components of the cooling system for engine water and compressor oil should be inspected every 250 hours of use. Any discrepancies found should be corrected before placing the unit back in operation. Unrestricted airflow over the radiator and oil cooler must be maintained at all times during operation.

H. Isolation Mounts

Engine/airend isolation mounts should be inspected after each 250 hours of operation. Those mounts with cracks or splits in the molded rubber, or with bent or broken bolts due to operation or storage in severe environments, all should be replaced with equivalent parts.

I. Engine Operation

Inspect and maintain engine condition and operation as recommended in the manuals supplied by the engine manufacturer.

J. Fuels and Lubricants

Use only the types and grades of fuels and lubricants recommended in the Ingersoll-Rand Company and Engine Manufacturer's Operator and Maintenance Manuals.

SECTION 4 - GENERAL DATA

MODEL:

P-()-W-JD-U		130	175	185
--------------	--	-----	-----	-----

Rated Delivery:

CFM- (litres/sec/)		130 (61)	175 (83)	185 (87)
--------------------	--	----------	----------	----------

Engine:

Full - RPM *Constant		2000	2350	2500
Idle - RPM		2000	1700	1700
Engine Model -		3029	3029	4045

COMPRESSOR

Rated Operating Pressure 100 psi (7.03 kgf per cm²) (700kPa)
 Safety Valve Setting 150 psi (10.5 kgf per cm²) (1030 kPa)

ENGINE (DIESEL)

Manufacturer John Deere
 Electrical System 12 Volt

FLUID CAPACITIES

	P185	P130 - P175
Compressor Lubricant	12 quarts (11.4 litres)	12 quarts (11.4 litres)
Engine Crankcase Lubricant (including filters)	9 quarts (8.5 litres)	6.3 quarts (6.0 litres)
Engine Coolant Capacity	14.4 quarts (13.6 litres)	11.6 quarts (11 litres)
Fuel Tank (Diesel)	28 U.S gal. (106 litres)	28 U.S gal. (106 litres)

UNITS MEASUREMENTS

WEIGHTS

Overall Length 85.3 (2165)
 Overall Height 52.3 (1327)
 Overall Width 33.3 (845)

	P185	P130 - P175
Net Weight (less fuel)	2265 (1027)	2020 lbs. (916 kg)
Gross Weight (all fluids)	2460 (1116)	2216 lbs. (1005 kg)

EXPENDABLE SERVICE PARTS

	P185	P100-P175
Compressor Oil Filter Element	Part No. 35296920	P/N 35296920
Compressor Oil Separator Element	Part No. 36845303	P/N 36845303
Air Filter Element	Part No. 35291970	P/N 35291970
Engine Oil Filter Element	Part No. 35308030	P/N 35308030
Engine Fuel Filter Element	Part No. 35389527	P/N 35389527

WARNING! Modification or alteration of this machine. Can result in severe injury or death. Do not modify or alter without the express written consent of Ingersoll-Rand Co.

SECTION 5 - OPERATION

CONTROL PANEL

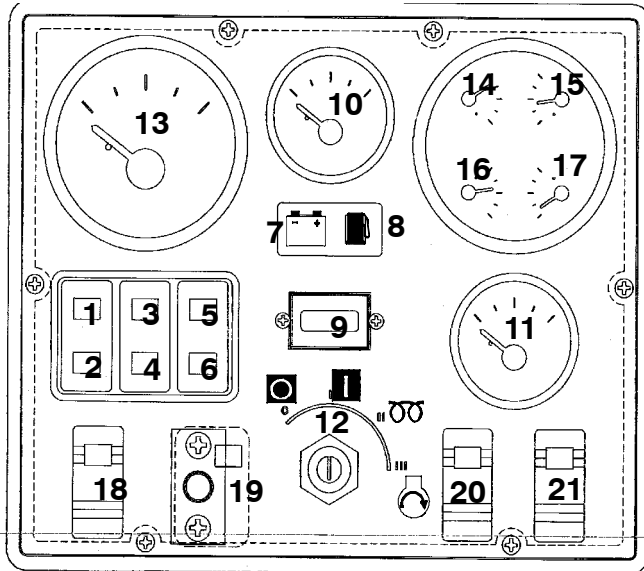

DIAGNOSTICS/AUTO SHUTDOWN (optional)

1. **High Engine Temperature** -
Coolant above 220°F (104°C) or more.
2. **Low Engine Oil Pressure** - 12 psi or less
3. **High Compressor Temperature** -
248°F (120°C).
4. **Air Filters Restricted** - Needs Servicing.
5. **Spare**
6. **Spare**

DIAGNOSTICS/AUTO SHUTDOWN (standard)

7. **Alternator Not Charging** - Needs attention
8. **Low Fuel Level** - Must add fuel to operate.
9. **Hourmeter** -
Records running time for maintenance.

10. **Compressor Discharge Pressure Gauge** -

Indicates pressure in receiver tank, psi (kPa).

11. **Fuel Level Gauge** -

Indicates amount of fuel in tank.

CONTROLS (Standard)

12. **Power Switch** - Flip "ON" to activate systems prior to Starting. Flip "OFF" to stop engine.

19. **Service Air Button** - After warm-up, PUSH. Provides full air pressure at the service outlet.

Indicates engine speed.

CONTROLS (Optional)

13. **Engine Speed Gauge** - Indicates engine speed.

14. **Discharge Air Temp. Gauge** -

Indicates in °F and °C. Normal operating range: 185°F/85°C to 248°F/120°C.

15. **Engine Oil Pressure Gauge** -

Indicates engine oil pressure.

16. **Engine Water Temp. Gauge** -

Indicates coolant temperature, with normal operating range from 180°F (82°C) to 210°F (99°C).

17. **Voltmeter** -

Indicates battery condition.

18. **Ether Inject Button** -

Injects a measured shot. **USE SPARINGLY.** (Not on WIR Models)

20. **Spare**

21. **Spare**

Begin with Serial Number 326650

UTILITY PACKAGE SET-UP

(no running gear)

INSTALLATION

The unit must be secured to a vehicle bed using mounting holes provided, to prevent unwanted motion of the unit while running or transporting. See Figure X for mounting holes provided in base.

The air going into the inlet grilles must be relatively free of oil, dirt, soot and other debris. It must be no more than 10 degrees F. (5 degrees C) over the ambient temperature.

The inlet and outlet grilles must not be restricted. See Figure Y for recommended clearance around the compressor. The cross-sectional area of any ductwork must be larger by a minimum of 10 percent.

The addition of any power-absorbing components (hydraulic pumps, paint mixers, etc.) must be approved by Ingersoll-Rand to maintain the warranty. Units with the optional engine-mounted auxiliary drive are approved for hydraulic pumps up to 15 HP.

CAUTION: Units with the optional engine mounted auxiliary drive and/or 4.5 kw generator can potentially overload the engine if the combination of air, hydraulic power and electrical power exceeds the Horsepower capability of the engine. This can lead to damage to the engine. Refer to Figure Z for the maximum HP available for the auxiliary drive.

High loading/continuous operation requires engine oil changes at 1/2 normal interval.

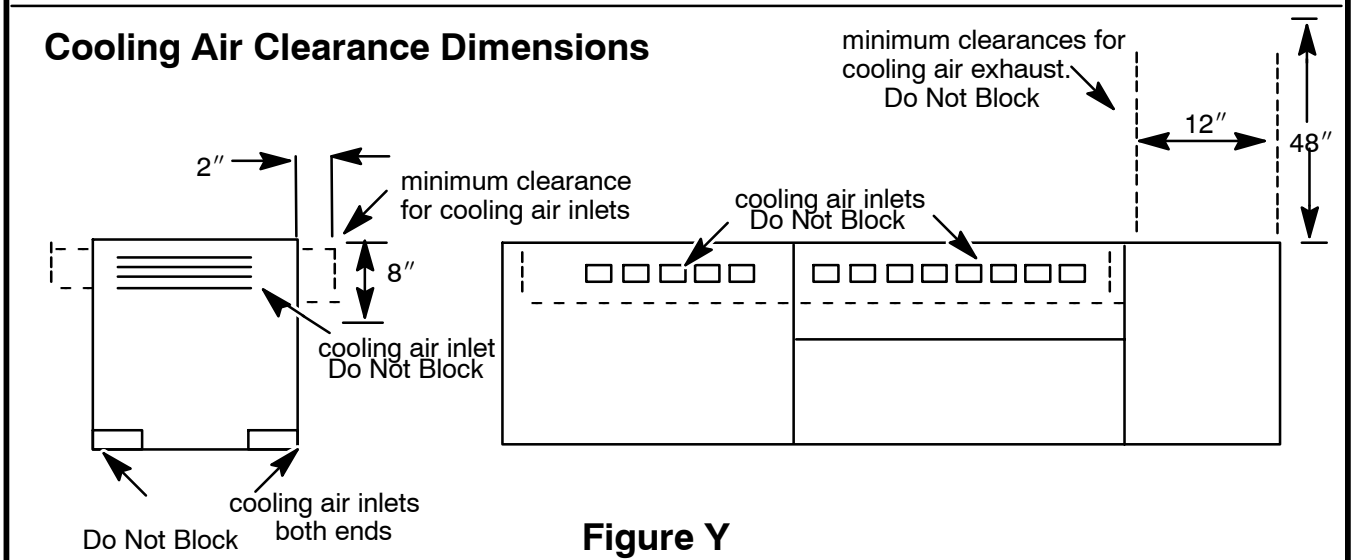
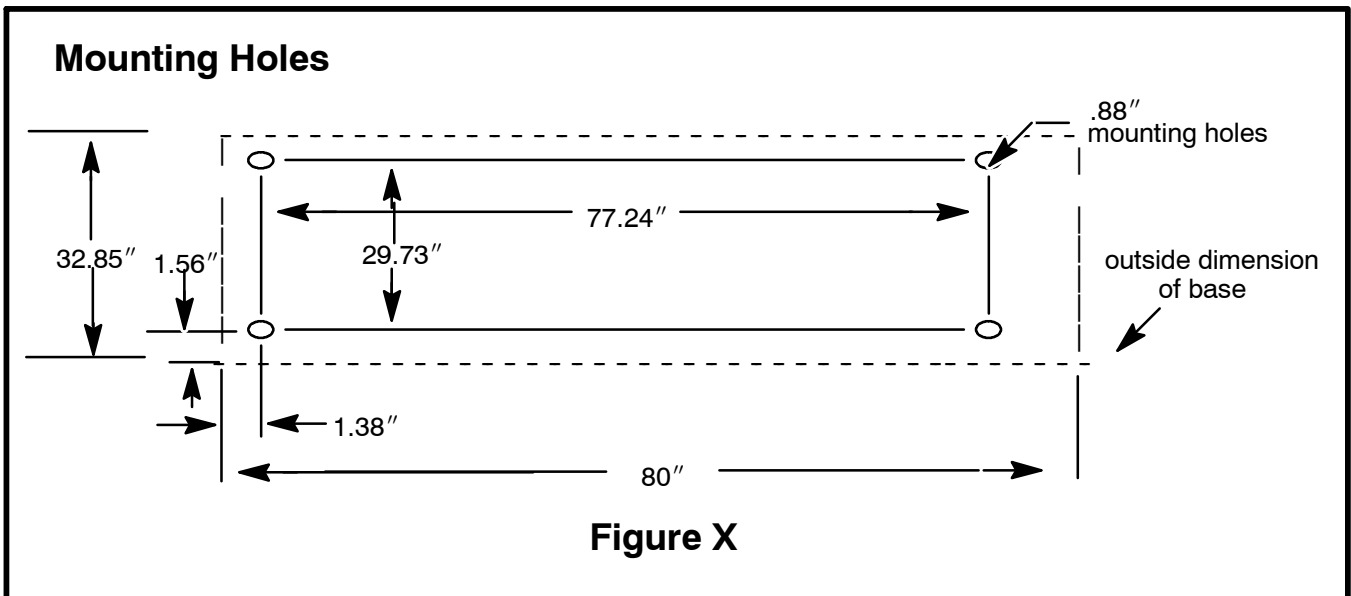

HOW TO USE THIS CHART:
 To determine HP available for auxiliary drive, enter chart at "CFM Used", move up to operating pressure line, read across for HP. Reduce HP according to altitude and power required for optional 4.5 kW generator.

HP Available for Aux. Drive vs. CFM Usage for P185AWJDU Compressor

Note: Engine SAE B-flange is rated at 30 HP max.

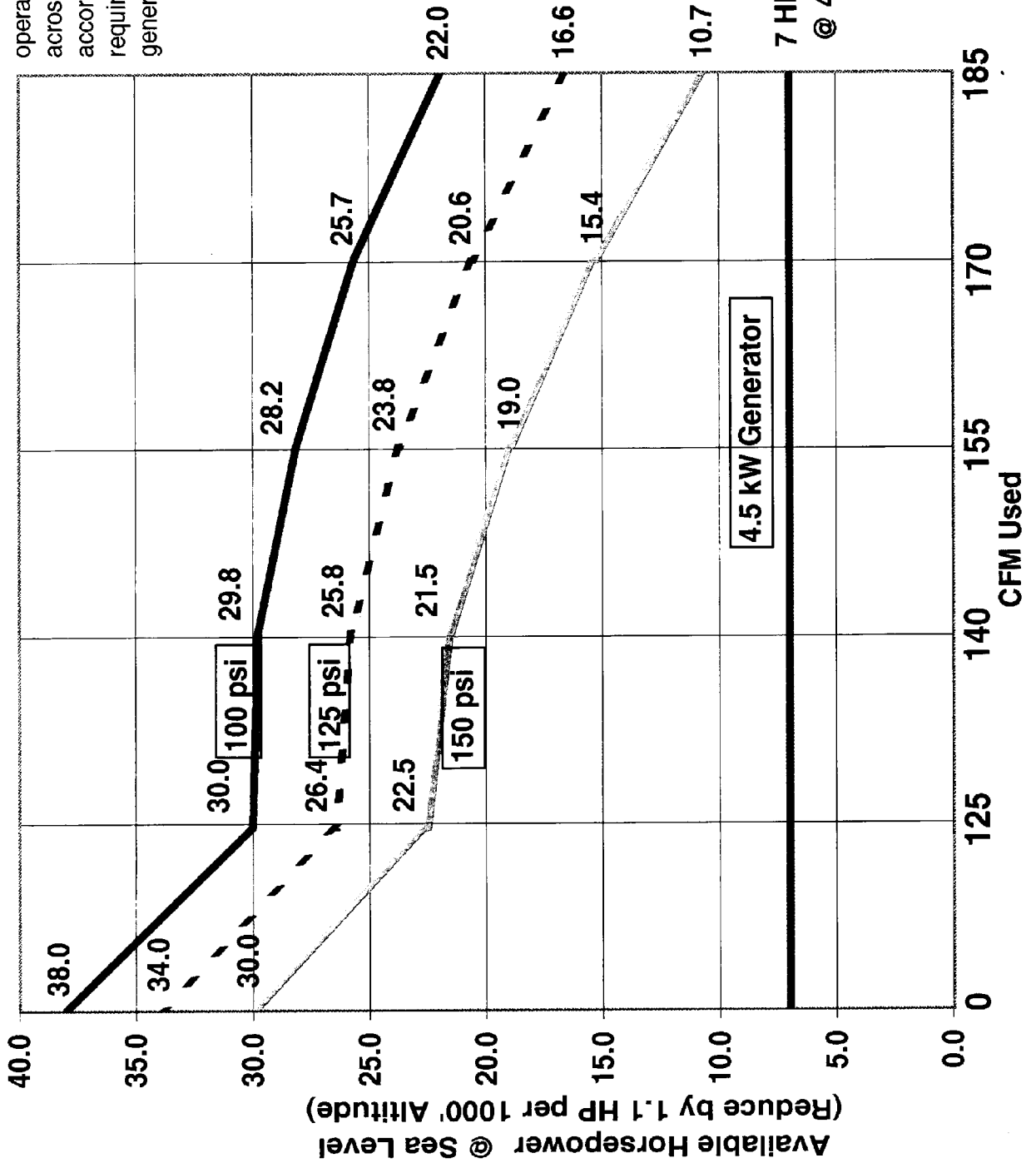

Figure Z

SETTING - UP (ALL UNITS)

- Position as level as possible. The design of these units permits a 15 degree sidewise limit on out-of-level operation.

- When the unit is to be operated out-of-level, it is important:

(1) To keep the engine crankcase oil level near the high level mark (with the unit level).

(2) To have the compressor oil level gauge show no more than mid-scale. Do not overfill either the engine crankcase or the compressor lubricating oil system.

(3) The side doors must be closed to maintain a cooling air path and to avoid recirculation hot air.

COMPRESSOR OIL LEVEL

The oil level should be checked before the unit is started. Always check the oil level while the unit is level, the engine off, and there is zero pressure in the separator tank. The optimum oil level is with the pointer at the top of the green section on the level gage. Add oil if the pointer reaches the bottom of the green section.

Note: The oil level gage will not read properly while the engine is running.

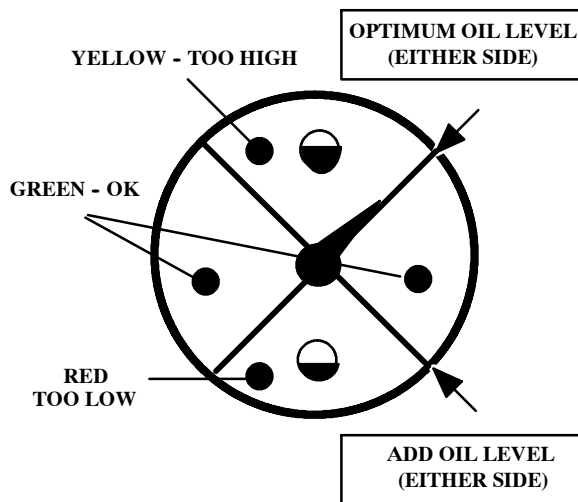

CAUTION

Do not remove pressure cap from a HOT radiator. Allow radiator to cool down before removing pressure cap. Use extreme care when

removing a pressure cap from a liquid cooling system for the engine. The sudden release of pressure from a heated cooling system can result in a loss of coolant and possible severe personal injury.

WARNING

NO SMOKING, SPARKS or OPEN FLAME near fuel.

CAUTION

Do not connect the air discharge on this unit into a common header with any other unit of any description, or any other source of compressed air, without first making sure a check valve is used between the header and the unit. If this unit is connected with another unit, a safety hazard could occur.

WARNING

Unrestricted air flow from a hose will result in a whipping motion of the hose which can cause severe injury or death. A safety device must be attached to the hose at the source of supply to reduce pressure in case of hose failure or other sudden pressure release. Reference: OSHA regulation 29 CFR Section 1926.302 (b).

BEFORE STARTING:

- All checks should be made while the unit is level.
- Open service valve (s) to ensure pressure is relieved in receiver-separator system. Close valve (s) in order to build up full air pressure and ensure proper oil circulation.
- Check battery for proper connections and condition.
- Check the engine oil level. Maintain per marks on dipstick.
- Check the fuel level. Add only CLEAN DIESEL fuel for maximum service from the engine.
- Check the compressor lubricating oil level. The optimum oil level is with the pointer at the top of the green section on the level gages. Add oil if the pointer reaches the bottom of the green section. Do not overfill.

Check the coolant level in the radiator and overflow bottle.

The coolant must cover the tubes in the top tank (approximately 1 inch high on a clean measuring rod stuck down filler neck). The coolant in the overflow bottle should be above the "COLD" mark for cold engine (<120°F).

A fuel level gauge reading can be obtained without starting the unit, by turning the power switch to "ON". Afterwards, turn the switch to "OFF".

Check the fuel level. Use Clean DIESEL fuel for maximum service from the engine.

WARNING

This machine produces loud noise with doors open. Extended exposure to loud noise can cause hearing loss. Wear hearing protection when doors or valve (s) are open.

- Close all doors to maintain a cooling air path and to avoid recirculation of hot air. This will maximize the life of the engine and compressor and protect the hearing of surrounding personnel.
- Be sure no one is IN or ON the compressor unit.

STARTING

Turn the POWER switch to "ON".

If so equipped, place the "Start-Run" Valve Switch, located in the bottom right hand corner of the instrument panel, to the "Start/Warm-Up" position.

Turn Power switch to "START" position to crank engine. Hold switch in "START" position for approximately 5 seconds after engine starts.

NOTICE

Do not operate the starter motor for more than 10 seconds without allowing at least 30 seconds cooling time between start attempts.

Release Power Switch (it will automatically move to the "ON" position) when the engine starts and sustains running.

Allow engine to warm up 5 to 10 minutes.

If so equipped, place the "Start-Run" Valve Switch in the "AIR" position.

Cold Weather Starting:

If so equipped, place the Start-Run valve switch, located in the bottom right hand corner of the instrument panel, to the "START/WARM-UP" position.

Open manual blowdown valve, if so equipped, and press ether inject button. Use Ether sparingly. Close manual blowdown valve after engine is running.

If equipped with the optional cold starting aid (ETHER), operate the valve once or twice ONLY while the engine is cranking.

CAUTION

Ether is an extremely volatile, highly flammable gas. Use sparingly! If too much is injected, the uncontrolled explosion may result in costly damage to the engine.

CAUTION

Exercise extreme caution when using a booster battery to start. To jump start: Connect the ends of one booster cable to the positive (+) terminals of each battery. Then connect one end of the other cable to the negative (-) terminal of the booster battery and the other end to the engine block. NOT TO THE NEGATIVE (-) TERMINAL OF THE WEAK BATTERY.

AFTER STARTING:

- Reduce engine speed to IDLE.
- Disconnect the negative (-) cable from the engine block first, then from the booster battery.
- Disconnect positive (+) cable from both batteries.

CAUTION

Do not remove pressure cap from a HOT radiator. Allow radiator to cool down before removing pressure cap. Use extreme care when removing a pressure cap from a liquid cooling system for the engine. The sudden release of pressure from a heated cooling system can result in a loss of coolant and possible severe personal injury.

Hose Reel Operation

To Unwind Hose

1. Disconnect end of hose from docking port at bottom right-hand corner of compressor.
2. Release reel lock pin on left-hand side of reel by pulling and rotating pin toward cradle and releasing it.
3. Pull hose to unwind.
4. Re-engage reel lock pin into reel.

To Retract Hose

1. Release reel lock pin on left-hand side of reel, by pulling and rotating pin toward cradle and releasing it.
2. Push and hold in "Reel Rewind" button at bottom right-hand corner of compressor.

WARNING: Keep Hands AWAY from Hose Reel while controlling hose.

3. Secure end of hose into docking port.
4. Reengage reel lock pin into reel.

To Swing Hose Reel Away from Compressor Door

1. Disconnect end of hose from docking port at bottom right-hand corner of compressor.
2. Release latch on right-side of hose reel frame.
3. Swing hose reel out, away from compressor door.

CAUTION: Hose Reel Must Be Returned To It's Latched Position Before Moving Vehicle.

OPERATION OF OPTIONAL GENERATOR

This unit will operate in three modes, depending on the position of the generator control switch (located on the front of the generator control panel).

- In "Generator" position, the engine will maintain idle speed, and the generator will give a constant voltage and frequency output, for use with sensitive equipment like computers, fusion welders, etc. No

compressed air is available at the service air valves in this mode.

- In "Gen/Air" position, voltage and frequency will vary as engine speed changes to meet air demands, and should only be used for lights and hand tools.
- In "Air" position, the generator provides no electrical power.

1. Start compressor with the Start-Run Switch located in the bottom right corner of the instrument panel) in the "Start/Warm-up" position.
2. Close all service air valves.
3. Place the start-run switch in the "Run" position.
4. Place the generator control switch in either "Generator" or "Gen/Air" position. The red light on the front of the generator control panel should glow, and the voltage meter should read 120 Volts AC.
5. Plug electric tools or lights into the receptacles on the front of the generator control panel.

-

Units with Diagnostic Lamps:

In a shutdown situation, the function of the panel lamps is to indicate what specific failure caused the unit to shut down. These lamps will remain illuminated until the Power Switch is turned "OFF".

UNITS WITH OPTIONAL DIAGNOSTICS LAMPS

NOTICE

None of the panel lamps should be glowing when machine is operating. If they are, shut unit down and refer to Trouble Shooting Section.

STOPPING

Close air service valve.

Allow the unit to run at idle for 3 to 5 minutes to reduce the engine temperatures.

Turn Power Switch to "OFF" position.

When the engine stops, automatic blowdown valve should relieve system air pressure. If automatic blowdown valve malfunction is suspected, open manual blowdown valve.

Never allow unit to sit under pressure when engine is not running.

WARNING

Since the service valve is closed, air downstream of the valve may be trapped. A vent hole in the service valve will slowly bleed air from the hose. Do not disconnect hoses until all pressure has been vented.

AUTOMATIC SHUTDOWN

This unit is protected with sensors (switches) for high discharge air temperature, high engine coolant temperature and low engine oil pressure.

Should any of three situations occur, the unit will stop. Before restarting the unit, check these three areas for excessive heat and fluid level. Other possible causes are listed on the Trouble Shooting Chart.

All units in this family of machines are protected by sensors or switches at the following locations:

- (1) Low engine oil pressure, in the engine.
- (2) High engine coolant temperature, in the engine.

High Discharge AIR Temperature

- (3) At the airend outlet.
- (4) In separator tank.

NOTICE

Do NOT wire around or bypass a shutdown sensor or switch.

DANGER

Even after pressure is relieved from the receiver-separator system, any air supply line from the compressor to a tool or a machine could remain under pressure and cause very serious personal injury or death. After the compressor stops, carefully open a valve at any tool or machine to exhaust the pressure in any line prior to removal or servicing.

P130WJDU Speed and Pressure Regulator Adjusting Instructions

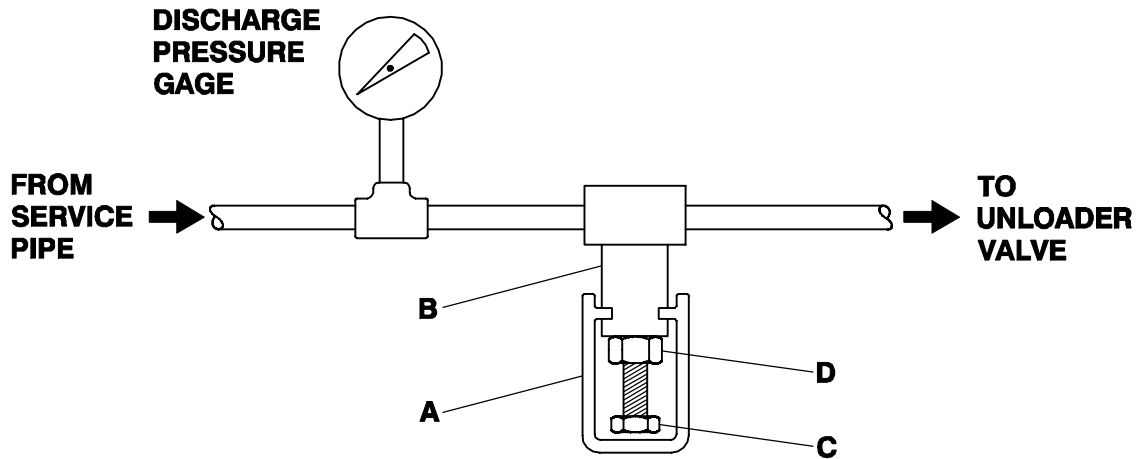

36511947

Normally, speed and pressure regulation requires no adjusting, but if proper adjustment is lost, proceed as follows. Refer to the General Data table for proper engine speeds.

Before Starting

1. Remove regulator valve cover (A), (if equipped) on valve (B) to expose adjusting screw (C). Loosen jam nut (D) on adjusting screw (C) and turn screw counterclockwise until tension is no longer felt on screw. Now, turn screw clockwise one full turn.
2. Close service valve(s).

After Starting Unit

3. Allow unit to warm up at least five minutes, then if equipped, place the Start-Run Valve Switch in the "AIR" position to obtain full service air pressure.
4. With Service Air Valve closed, turn the adjusting screw (C) clockwise until the discharge pressure reaches 120 psi (range =20psi). Tighten jam nut (D).
5. Replace regulator valve cover (A), if equipped.
6. To select any pressure range fro 85 to 100 psi, change adjusting screw (C) to obtain a "closed" service valve pressure that is 20 psi greater than the desired "working" service pressure. Always lock and protect pressure setting of adjusting screw (C) with jam nut (D) and regulator valve cover (A).

P175 - 185 Speed and Pressure Regulator Adjusting Instructions

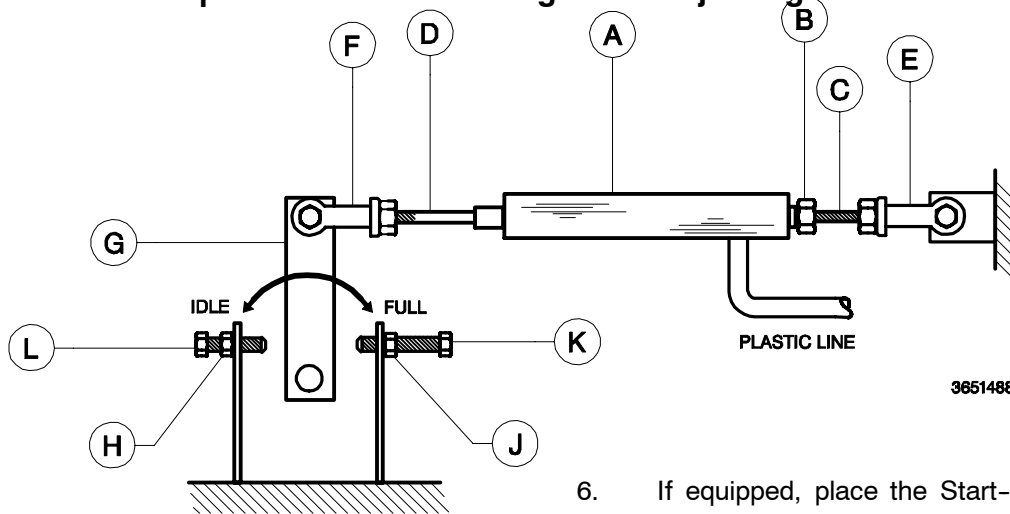

The engine idle and full speed settings are set and sealed at the factory, and should not be adjusted. Serious injury may result if the full speed is increased. Removal of the seals without authorization could affect the warranty. If speed settings are lost due to engine fuel pump service or other repairs, the speed settings can be reset as follows:

Before Starting

1. At the Pressure Regulator (on service pipe near receiver tank), remove the cover to expose the adjusting screw. Loosen the jam nut and turn screw counterclockwise until tension is no longer felt at the screw. Then, turn screw clockwise one full turn.
2. Close service valve(s).
3. At air cylinder (A), loosen jam nut (B) on adjusting rod (C). Turn rod (C) until it just touches the piston inside of the cylinder. This is determined by the movement of the air cylinder piston rod (D). Rod (D) should be fully retracted and just begin to extend when the adjusting rod (C) is properly set.
4. Lock jam nut (B).

After Starting Unit

5. Allow unit to warm up at an engine speed greater than IDLE speed (*) for at least five minutes. Do this by loosening jam nut (H) on the IDLE screw (L). Turn the IDLE screw until the speed is properly set (*).

6. If equipped, place the Start-Run Valve Switch to the "AIR" position. The unit should speed up and then unload (and drop back to IDLE). With the unit unloaded, turn the adjusting screw on the pressure regulator clockwise until the discharge pressure gauge indicates 125-130 psi. Tighten the pressure regulator jam nut. Replace cover.

7. Open the service valve and adjust the discharge pressure to 100 psi (700 kPa). Now turn adjusting rod (C) until the proper engine FULL speed setting (*) is reached.
8. If necessary, loosen jam nut (J) on FULL speed screw (K) and turn screw until it hits a stop. Recheck the FULL speed setting and reset if required. Tighten jam nuts (J) and (H).
9. Close the service valve and recheck IDLE speed (*). If necessary, adjust speed using screw (L). Tighten jam nut (H).
10. To obtain maximum cfm at any pressure between 80 psi (550 kPa) and maximum pressure rating (*), make adjustment at the pressure regulator to obtain desired discharge pressure at FULL engine speed. Lock adjusting screw and replace cover.

* See General Data Specifications.

SECTION 6 - MAINTENANCE

CAUTION

Any unauthorized modification or failure to maintain this equipment may make it unsafe and out of factory warranty.

If performing more than visual inspections, disconnect battery cables and open manual blowdown valve.

Use extreme care to avoid contacting hot surfaces (engine exhaust manifold and piping, air receiver and air discharge piping, etc.).

Never operate this machine with any guards removed.

Inch and metric hardware was used in the design and assembly of this unit. Consult the parts manual for clarification of usage.

Notice: Disregard any maintenance pertaining to components not provided on your machine.

GENERAL

In addition to periodic inspections, many of the components in these units require periodic servicing to provide maximum output and performance. Servicing may consist of pre-operation and post-operation procedures to be performed by the operating or maintenance personnel. The primary function of preventive maintenance is to prevent failure, and consequently, the need for repair. Preventive maintenance is the easiest and the least expensive type of maintenance. Maintaining your unit and keeping it clean at all times will facilitate servicing.

SCHEDULED MAINTENANCE

The maintenance schedule is based on normal operation of the unit. This page can be reproduced and used as a checklist by the service personnel. In the event unusual environmental operating conditions exist, the schedule should be adjusted accordingly.

COMPRESSOR OIL LEVEL

The oil level should be checked before the unit is started. Always check the oil level while the unit is level, the engine off, and there is zero pressure in the separator tank. The optimum oil level is with the pointer at the top of the green section on the level gage. Add oil if the pointer reaches the bottom of the green section.

Note: The oil level gage will not read properly while the engine is running.

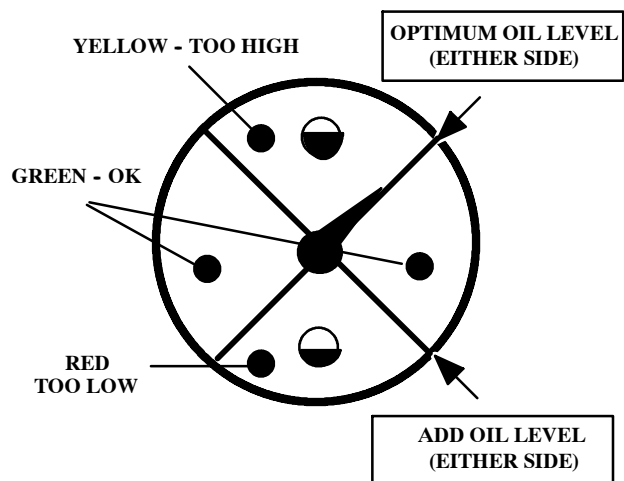

AIR CLEANER

If this unit is equipped with the Optional Diagnostic Panel, it has an AIR FILTERS RESTRICTED lamp on the instrument panel, covering both the engine and the compressor.

This should be checked daily during operation. If the lamp glows (red) with the unit operating at full speed, servicing of the cleaner element is necessary.

Also weekly squeeze the rubber valve (precleaner dirt dump) on each air cleaner housing to ensure that they are not clogged.

The air filters restricted sensor will automatically reset after the main power switch is turned to "OFF."

To service the air cleaners on all units proceed as follows:

1. Loosen outer wing nut and remove with cover. Remove Element.
2. Inspect air cleaner housing for any condition that might cause a leak and correct as necessary.
3. Wipe inside of air cleaner housing with a clean, damp cloth to remove any dirt accumulation, especially in the area where the element seals against the housing.
4. Inspect element by placing a bright light inside and rotating slowly. If any holes or tears are found in the paper, discard this element. If no ruptures are found, the element can be cleaned.
5. If a new air filter element is to be used check it closely for shipping damage.
6. Install cleaned or new elements in the reverse order to the above. Tighten wing nut firmly.
7. Inspect to ensure that the end cap seals tightly 360 degrees around the air cleaner body.

In the event that the filter element must be reused immediately, compressed air cleaning (as follows) is recommended since the element must be thoroughly dry. Direct compressed air through the element in the direction opposite to the normal air flow through the element.

Move the nozzle up and down while rotating the element. Be sure to keep the nozzle at least one inch (25.4 mm) from the pleated paper.

NOTE: To prevent damage to the element, never exceed a maximum air pressure of 100 psi (700 kPa).

In the event the element is contaminated with dry dirt, oil or greasy dirt deposits, and a new element is not available, cleaning can be accomplished by washing, using the air cleaner element manufacturer's recommendations.

NOTE: It is recommended that replacement elements be installed in the unit. The elements just removed for cleaning can be washed and stored as future replacement elements.

In addition, the air cleaner system (housing and piping) should be inspected every month for any leakage paths or inlet obstructions. Make sure the air cleaner mounting bolts and clamps are tight. Check the air cleaner housing for dents or damage which could lead to a leak. Inspect the air transfer tubing from the air cleaner to the compressor and the engine for leaks.

Make sure that all clamps and flange joints are tight.

GAUGES

The instruments or gauges are essential for safety, maximum productivity and long service life of the machine. Inspect the gauges and test any diagnostic lamps prior to start-up. During operation observe the gauges and any lamps for proper functioning. Refer to Operating Controls, for the normal readings.

FUEL TANK

CLEAN fuel in the fuel tanks is vitally important and every precaution should be taken to ensure that only clean fuel is poured or pumped into the tank.

When filling the fuel tank on this unit, by methods other than a pump and hose, use a CLEAN non-metallic funnel.

BATTERY

Keep the battery posts-to-cable connections clean, tight and lightly coated with a grease. Also the electrolyte level in each cell should cover the top of the plates. If necessary, top-up with clean distilled water.

FASTENERS

Visually check entire unit in regard to bolts, nuts and screws being properly secured. Spot check several capscrews and nuts for proper torque. If any are found loose, a more thorough inspection must be made. Take corrective action.

RADIATOR

NOTICE

The use of water alone in this engine can result in major engine failure.

HOSES

Each month it is recommended that all of the intake lines to and from the air cleaners, the engine cooling system hoses and all of the flexible hoses used for air, oil, and fuel be inspected.

To ensure freedom from air leaks, all rubber hose joints and the screw-type hose clamps must be absolutely tight. Regular inspection of these connections for wear or deterioration is necessary.

Premature wear of both the engine and compressor is ASSURED whenever dust-laden air is permitted to enter the engine's combustion chamber or the compressor intake.

The flexible hoses used in the fuel, oil and air lines on these units are primarily used for their ability to accommodate relative movement between components. It is important they be periodically inspected for wear and deterioration. It is also important the operator does not use the hoses as convenient hand hold or steps. Such use can cause early cover wear and hose failure.

NOTICE

Piping systems operating at less than 150 psi (1050 kPa) may use a special nylon tubing. The associated fittings are also of a special "push-in" design. If so, features are as follows:

Pulling on the tubing will cause the inner sleeve to withdraw and compress, thus tightening the connection. The tubing can be withdrawn only while holding the sleeve against the fitting. The tubing can be removed and replaced numerous times without losing its sealing ability.

To install the nylon tubing, make a mark (with tape or grease pencil) approximately 7/8 inch from the end of the tubing. Insert the tubing into the sleeve and "push-in" past the first resistance to the bottom. The mark should be approximately 1/16 inch from the sleeve, for the 3/8 inch O.D. tubing; 1/8 inch for the 0.25 inch O.D. tubing. This will ensure that the tubing is fully engaged in the sealing mechanism.

NOTICE

The oil filter must be replaced every 500 hours of operation or three (3) months, whichever comes first. On new or overhauled units, replace the element after the first 50 and 150 hours of operation; thereafter, service the oil filter every 500 hours.

To service the oil filters it will first be necessary to shut the unit down. Wipe off any external dirt and oil from the exterior of the filter to minimize any contamination from entering the lubrication system. Proceed as follows:

WARNING

High pressure air can cause severe injury or death from hot oil and flying parts. Always relieve pressure before removing caps, plugs, covers or other parts from pressurized air system.

1. Open the service air valve(s) to ensure that system is relieved of all pressure. Close the valve(s).
2. Turn the spin-on filter element counterclockwise to remove it from the filter housing. Inspect the filter.

NOTICE

If there is any indication of formation of varnishes, shellacs or lacquers on the oil filter element, it is a warning the compressor lubricating oil has improper characteristics and should be immediately changed.

3. Inspect the oil filter head to be sure the gasket was removed with the oil filter element. Clean the gasket seal area on the oil filter head.

NOTICE

Installing a new oil filter element when the old gasket remains on the filter head, will cause an oil leak and can cause property damage

1. Lubricate the new filter gasket with the same oil being used in the machine.
2. Install new filter by turning element clockwise until gasket makes initial contact. Tighten an additional 1/2 to 3/4 turn.
3. Start unit and allow to build up to rated pressure. Check for leaks before placing unit back into service.

COMPRESSOR OIL COOLER

The compressor lubricating and cooling oil is cooled by means of the fin and tube-type oil cooler, located beside the radiator. The lubricating and cooling oil, flowing internally through the core section, is cooled by the air stream from the cooling fan flowing past the core section. When grease, oil and dirt accumulate on the exterior surfaces of the oil cooler, its efficiency is impaired.

Each month it is recommended that the oil cooler be cleaned by directing compressed air which contains a nonflammable, non-caustic safety solvent through the core of the oil cooler. This should remove the accumulation of grease, oil and dirt from the exterior surfaces of the oil cooler core so that the entire cooling area can transmit the heat of the lubricating and cooling oil to the air stream.

In the event foreign deposits, such as sludge and lacquer, accumulate in the oil cooler to the extent that its cooling efficiency is impaired, a resulting high discharge air temperature is likely to occur, causing shut down of the unit. To correct this situation it will be necessary to clean it using a cleaning compound in accordance with the manufacturer's recommendations.

COMPRESSOR OIL

The lubricating and cooling oil must be replaced every 500 hours of operation or six (6) months, whichever comes first.

RECEIVER-SEPARATOR SYSTEMS

WARNING

High pressure air can cause severe injury or death from hot oil and flying parts. Always relieve pressure before removing caps, plugs, covers or other parts from pressurized air system.

- **Open service valve at end of machine.**
- **Ensure pressure is relieved, with BOTH:**
 - **Discharge air pressure gauge reads zero (0).**
 - **No air discharging from service valve.**

When draining oil, remove plug from the separator tank drain fitting.

When adding oil, remove and replace (make tight) plug on side of separator tank.

In the compressor lubricating and cooling system, separation of the oil from the compressed air takes place in the receiver-separator tank. As the compressed air enters the tank, the change in velocity and direction drop out most of the oil from the air.

Additional separation takes place in the oil separator element which is located in the top of the tank.

Any oil accumulation in this separator element is continuously drained off by means of a scavenge tube which returns the accumulated oil to the system.

The life of the oil separator element is dependent upon the operating environment (soot, dust, etc.) and should be replaced every twelve months or 2000 hours. To replace the element proceed as follows:

- Ensure the tank pressure is zero.
- Disconnect the hose from the scavenge tube.
- Remove scavenge tube from tank cover.
- Disconnect service line from cover.
- Remove cover mounting screws.
- Remove cover and element.
- Remove any gasket material left on cover or tank.
- Install new element.

NOTICE

Do not remove staples from the element/gasket connection.

- Place a straightedge across top of element and measure from bottom of straightedge to bottom of element (See Fig. 4.1).

- Replace scavenge tube in cover (cover is still off of tank).

- Measure from bottom of cover to end of scavenge tube. Measurement should be from 1/8" to 1/4" less than the element measurement. If not, cut to size.

- Remove scavenge tube.

- Reposition cover (use care not to damage gaskets).

- Replace cover mounting screws: tighten in a criss-cross pattern.

- Reconnect service line. Replace scavenge tube. Reconnect hose.

- Close service valve. Start unit and look for leaks.

When replacing the element, the scavenge lines, orifice, filter, and check valve should be thoroughly cleaned and the oil changed.

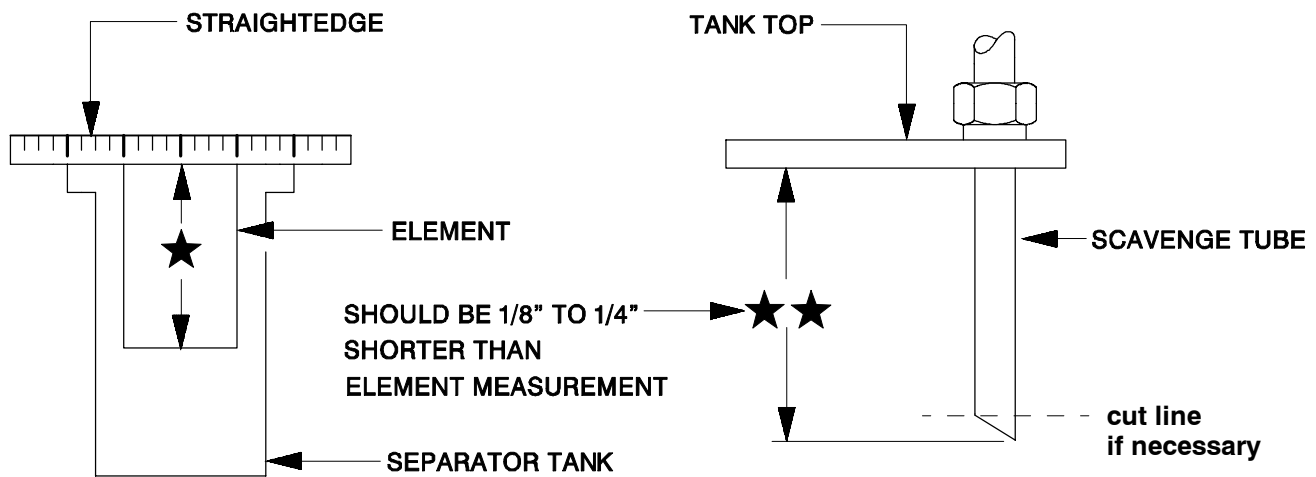

SCAVENGE LINE

WARNING

High pressure air can cause severe injury or death from hot oil and flying parts. Always relieve pressure before removing caps, plugs, covers or other parts from pressurized air system.

The scavenge line originates at the receiver-separator tank cover and terminates at the compressor air-end near the oil filter element. An orifice check valve is located on the scavenge tube.

Once a year or every 1000 hours of operation, whichever comes first, replace the separator element and clean the scavenge orifice/check valve.

NOTE: Excessive oil carry-over may be caused by an oil-logged separator element. Do not replace element without first performing the following maintenance procedure:

1. Check oil level. Maintain as indicated earlier in this section.
2. Thoroughly clean scavenge line, any orifice and check valve.
3. Assure minimum pressure valve/orifice is operational.
4. Run unit at rated operating pressure for 30 to 40 minutes to permit element to clear itself.

EXTERIOR FINISH CARE

This unit was painted and heat cured at the factory with a high quality, thermoset polyester powder coating. The following care will ensure the longest possible life from this finish.

1. If necessary to remove dust, pollen, etc. from housing, wash with water and soap or dish washing liquid detergent. Do not scrub with a rough cloth, pad, etc.
2. If grease removal is needed, a fast evaporating alcohol or chlorinated solvent can be used. Note: This may cause some dulling of the paint finish.

3. If the paint has faded or chalked, the use of a commercial grade, non-abrasive car wax may partially restore the color and gloss.

Field Repair of Texture Paint

1. The sheet metal should be washed and clean of foreign material and then thoroughly dried.
2. Clean and remove all grease and wax from the area to be painted using Duponts 3900S Cleaner prior to sanding.
3. Use 320 grit sanding paper to repair any scratches or defects necessary.
4. Scuff sand the entire area to be painted with a red scotch brite pad.
5. Wipe the area clean using Duponts 3900S.
6. Blow and tack the area to be painted.
7. Apply a smooth coat of Duponts 1854S Tuffcoat Primer to all bare metal areas and allow to dry.
8. Apply 2 medium - wet coats of Duponts 222S Adhesion Promoter over the entire area to be painted, with a 5 minute flash in between coats.
9. To apply the texture coat, use Duponts 1854S Tuffcoat Primer. The proper technique to do this is to spray the Tuffcoat Primer using a pressure pot and use about 2-5 pounds of air pressure. This will allow the primer to splatter causing the textured look. Note: you must be careful not to put too much primer on at one time, this will effect the amount of texture that you are trying to achieve. Allow the texture coat to flash for 20 minutes or until dry to touch.
10. Apply any of Duponts Topcoat Finishes such as Imron™ or Centari™ according to the label instructions.

Note: To re-topcoat the textured surfaces when sheet metal repairs are not necessary, follow steps 1, 2, 4, 5, 6, 8 and 10.

MAINTENANCE SCHEDULE

These time periods should be reduced if operating in extreme conditions (very hot, cold, dusty or wet).

	Daily	Weekly	Monthly	3 MOS .	6 MOS.	12 MOS.
SMALL UNITS (P100-P600)				250 hours	500 hours	1000 hours
LARGE UNITS (HP600-P1600)				500 hours	1000 hours	2000 hours
**Hydraulic Oil Level		C			R	
Compressor Oil Level	C					
Engine Oil Level	C					
**Radiator Coolant Level	C					
Gauges/Lamps	C					
Air Cleaner Service Indicators	C					
Fuel Tank (fill at end of day)	C				DRAIN	
**Fuel/Water Separator	DRAIN C					
Air Cleaner Precleaner Dumps		C				
Fan/Alternator Belts		C				
Battery Connections/Electrolyte		C				
**Tire Pressure and Surface		C				
**Wheel Lug Nuts			C			
Hoses (oil, air, intake, etc.)			C			
Automatic Shutdown System	Test		C			
Air Cleaner System	Visual		C			
Compressor Oil Cooler	Exterior		C	CLEAN		
**Engine Radiator	Exterior		C	CLEAN		
Fasteners, Guards				C		
Air Cleaner Elements				WI		
** Fuel/Water Separator Element					R	
*Compressor Oil Filter Element				B	A	
*Compressor Oil					R	
**Wheels (bearings, seals, etc)					C	C
Engine Coolant	Test				C	R
Shutdown Switch Settings	Test					C
Scavenge Orifice & related parts						CLEAN
Oil Separator Element						R
**Lights (running, brake, & turn)	CBT					
**Pintle Eye Bolts	CBT					
Engine (oil changes, oil & fuel filters, etc)				R		

**Disregard if not appropriate for this particular machine.

*NXP Units - consult manual

R=replace, **C**=check (adjust if necessary), **WI**=OR when indicated, **CBT** = check before towing.

A = Small Units

B = Large Units

Refer to specific sections of the operator's manual for more information.

SECTION 7 - LUBRICATION

GENERAL INFORMATION

Lubrication is an essential part of preventive maintenance, affecting to a great extent the useful life of the unit. Different lubricants are needed and some components in the unit require more frequent lubrication than others. Therefore, it is important that the instructions regarding types of lubricants and the frequency of their application be explicitly followed. Periodic lubrication of the moving parts reduces to a minimum the possibility of mechanical failures.

The Preventive Maintenance Schedule shows those items requiring regular service and the interval in which they should be performed. A regular service program should be developed to include all items and fluids. These intervals are based on average operating conditions. In the event of extremely severe (hot, cold, dusty or wet) operating conditions, more frequent lubrication than specified may be necessary. Details concerning lubrication of the running gear are in Maintenance Section.

All filters and filter elements for air and compressor lubricant must be obtained through Ingersoll-Rand to assure the proper size and filtration for the compressor.

COMPRESSOR OIL CHANGE

These units are normally furnished with an initial supply of oil sufficient to allow operation of the unit for approximately 6 months or 1000 hours, whichever comes first. If a unit has been completely drained of all oil, it must be refilled with new oil before it is placed in operation. Refer to specifications in Lubrication Table.

NOTICE

Some oil types are incompatible when mixed and result in the formation of varnishes, shellacs, or lacquers which may be insoluble. Such deposits can cause serious troubles including clogging of the filters. Where possible, do NOT mix oils of different types and avoid mixing different brands. A type or brand change is best made at the time of a complete oil drain and refill.

If the unit has been operated for the time/ hours mentioned above, it should be completely drained of oil. If the unit has been operated under adverse conditions, or after long periods in storage, an earlier change period may be necessary as oil deteriorates with time as well as by operating conditions.

WARNING

High pressure air can cause severe injury or death from hot oil and flying parts. Always relieve pressure before removing caps, plugs, covers or other parts from pressurized air system. Ensure the following conditions are met:

- Discharge air pressure gauge reads zero (0).
- No air discharging from an "open" manual blowdown valve.

An oil change is good insurance against the accumulation of dirt, sludge, or oxidized oil products.

Completely drain the receiver- separator, piping, and oil cooler. If the oil is drained immediately after the unit has been run for some time, most of the sediment will be in suspension and, therefore, will drain more readily. However, the fluid will be hot and care must be taken to avoid contact with the skin or eyes.

After the unit has been completely drained of all old oil, close the drain valve. Add oil in the specified quantity at the filler plug. Tighten the filler plug and run the machine to circulate the oil. Check the oil level WHEN RUNNING AT FULL LOAD. If not near the middle of the sight tube, stop the unit and make corrections. DO NOT OVERFILL.

NOTICE

Ingersoll-Rand provides compressor oil specifically formulated for Portable Compressors and requires the use of these fluids in order to obtain extended limited airtend warranty.

Portable Compressor Fluid Chart

Refer to these charts for correct compressor fluid required. Note that the selection of fluid is dependent on the design operating pressure of the machine and the ambient temperature expected to be encountered before the next oil change.

Note: Fluids listed as “preferred” are required for extended warranty.

Compressor oil carryover (oil consumption) may be greater with the use of alternative fluids.

Design Operating Pressure	Ambient Temperature	Specification
100 psi to 300 psi	-10°F to 125°F (-23°C to 52°C)	Preferred: IR Pro-Tec™ Alternate: ISO Viscosity Grade 46 with rust and oxidation inhibitors, designed for air compressor service.
350 psi	(-23°C to 52°C) -10°F to 125°F 65°F to 125°F (-18°C to 52°C)	Preferred: IR XHP 605 Alternate: IR XHP405 ISO Viscosity Grade 68 Group 3 or 5 with rust and oxidation inhibitors designed for air compressor service. Preferred: XHP605 IR XHP1001

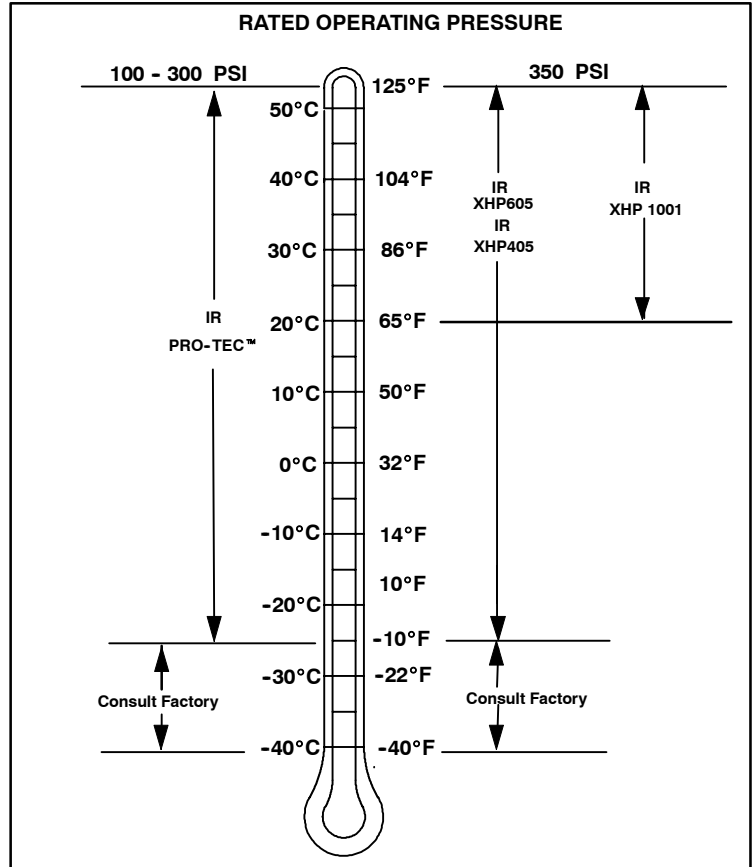

Preferred Ingersoll-Rand Fluids - Use of these fluids with original I-R filters can extend airtend warranty. Refer to operator's manual warranty section for details or contact your I-R representative.

Ingersoll-Rand Preferred Fluids	1 gal. (3.8 Litre)	5 gal. (19.0 Litre)	55 gal. (208.2 Litre)	220 gal. (836 litre)
Preferred:				
IR Pro-Tec™	36899698	36899706	36899714	36899722
IR XHP605	-	22252076	22252050	22252068
IR XHP1001	-	35612738	35300516	-
XHP405	-	22252126	22252100	22252118
Engine Oil	54480918	36875938	36866903	

SECTION 8 - Trouble Shooting

INTRODUCTION

Trouble shooting for a portable air compressor is an organized study of a particular problem or series of problems and a planned method of procedure for investigation and correction. The trouble shooting chart that follows includes some of the problems that an operator may encounter during the operation of a portable compressor.

The chart does not attempt to list all of the troubles that may occur, nor does it attempt to give all of the answers for correction of the problems. The chart does give those problems that are most apt to occur. To use the trouble shooting chart:

- A. Find the "complaint" depicted as a bold heading.
- B. Follow down that column to find the potential cause or causes. The causes are listed in order (1,2,3 etc.) to suggest an order to follow in trouble shooting.

ACTION PLAN

A. Think Before Acting

Study the problem thoroughly and ask yourself these questions:

- (1) What were the warning signals that preceded the trouble?
- (2) Has a similar trouble occurred before?
- (3) What previous maintenance work has been done?
- (4) If the compressor will still operate, is it safe to continue operating it to make further checks?

B. Do The Simplest Things First

Most troubles are simple and easily corrected. For example, most complaints are "low capacity" which may be caused by too low an engine speed or "compressor over- heats" which may be caused by low oil level.

Always check the easiest and most obvious things first; following this simple rule will save time and trouble.

Note: For trouble shooting electrical problems, refer to the Wiring Diagram Schematic found in Parts List Section.

C. Double Check Before Disassembly

The source of most compressor troubles can be traced not to one component alone, but to the relationship of one component with another. Too often, a compressor can be partially disassembled in search of the cause of a certain trouble and all evidence is destroyed during disassembly. Check again to be sure an easy solution to the problem has not been overlooked.

D. Find And Correct Basic Cause

After a mechanical failure has been corrected, be sure to locate and correct the cause of the trouble so the same failure will not be repeated. A complaint of "premature breakdown" may be corrected by repairing any improper wiring connections, but something caused the defective wiring. The cause may be excessive vibration.

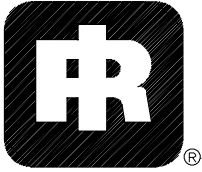

TROUBLE SHOOTING CHART

Bold Headings depict the COMPLAINT - Subheadings suggest the CAUSE

Note: Subheadings suggest sequence to follow troubleshooting.

1. Unit Shutdown:

Out of Fuel
Compressor Oil Temp. Too High
Engine Water Temp. Too High
Engine Oil Pressure Too Low
Broken Engine Fan Belt
Loose Wire Connection
Low Fuel Level Shutdown Switch
Defective Discharge Air Temp. Switch
Defective Engine Oil Pressure Switch
Defective Shutdown Solenoid
Malfunctioning Relay
* < 16 Volts at Shutdown Solenoid
Blown Fuse
Engine Malfunctioning
Airend Malfunctioning

Corrective Action

Add CLEAN diesel Fuel
See Complaint 10
Check coolant level. If necessary, Add.
See Complaint 3 and Complaint 4.
Replace fan belt.
Wiggle wires at switches & connector blocks. Make repairs.
Replace switch.
Replace switch.
Replace switch.
Replace solenoid.
Replace relay.
Check battery and alternator. Make repairs.
Replace fuse.
See Trouble Shooting in Engine Manual.
See Complaint 10.

2. Won't Start/Run:

Low Battery Voltage
* <16 Volts at Shutdown Solenoid
Blown Fuse
Malfunctioning Start Switch
Defective Safety Bypass Switch
Clogged Fuel Filters
Out of Fuel
Compressor Oil Temp. Too High
Engine Water Temp. Too High
Engine Oil Pressure Too Low
Loose Wire Connection
Defective Discharge Air Temp. Switch
Defective Engine Oil Pressure Switch
Defective Shutdown Solenoid
Malfunctioning Relay
Engine Malfunctioning
Airend Malfunctioning

Check electrolyte level. Check connections.
Charge battery and alternator. Make repairs.
Replace fuse.
Replace switch.
Replace switch.
Service filters. See Engine Operator's Manual.
Add CLEAN fuel.
See Complaint 10.
Check fluid level. If necessary, Add.
See Complaint 3 and Complaint 4.
Repair or replace connection.
Replace switch.
Replace switch.
Replace solenoid.
Replace relay.
See Trouble Shooting in Engine Manual.
See Complaint 10.

3. Engine Temperature Lamps Stays On:

Broken Engine Fan Belt
Malfunctioning Circuit Board
* Ambient Temp. >125°F (52°C)
Dirty Operating Conditions
Dirty Cooler
* Out of Level >15 degrees
Operating Pressure Too High
Recirculation of Cooling Air
Loose Wire Connection
Malfunctioning circuit board.

Replace fan belt set.
Replace circuit board.
Above spec limit.
Move unit to cleaner environment.
Clean exterior of cooler.
Relocate or reposition unit.
Reduce pressure to spec.
Close side doors.
Repair or replace.
Replace circuit board.

* : > = greater than, < = less than

4. Engine Oil Pressure Lamp Stays On:

Low Oil Level
Out of Level >15 degrees
Wrong Lube Oil
Clogged Oil Filter Element(s)
Engine Malfunctioning
Loose Wire Connection.
Malfunctioning circuit board

Corrective Action

Add oil.
Relocate or reposition.
See Engine Oil Spec. Change oil.
Replace element(s).
See Trouble Shooting in Engine Manual.
Repair or replace.
Replace circuit.

5. Engine Temperature Lamps Stays Off:

Bulb Burned Out
Malfunctioning circuit board

Replace circuit board.
Replace circuit board.

6. Engine Oil Pressure Lamp Stays Off:

Bulb Burned Out
Malfunctioning circuit board

Replace circuit board.
Replace circuit board.

7. Alternator Lamp Stays On:

Loose or Broken Belts
Loose Wire Connection
Low Battery Voltage

Malfunctioning Alternator
Malfunctioning circuit board

Tighten or replace belt set.
Repair or replace connection.
Check electrolyte level. Add if necessary.
Check connectors. Clean & tighten.
Recharge battery.
Repair or replace alternator.
Replace circuit board.

8. Alternator Lamp Stays Off:

Bulb Burned Out
Loose Wire Connection
Malfunctioning circuit board

Replace circuit board.
Repair or replace connector.
Replace circuit board.

9. Unit Fails To Shutdown:

Defective Low Fuel Shutdown Switch
Defective Discharge Air Temperature Switch
Defective Engine Oil Pressure Switch
Defective Shutdown Solenoid
Malfunctioning Relay
Defective Safety Bypass Switch

Pull wire off shutdown solenoid. Replace switch.
Pull wire off. Replace switch.
Pull wire off. Replace switch.
Carefully block air inlet to stop engine.
Replace solenoid.
Pull wire off shutdown solenoid. Replace relay.
Pull wire off shutdown solenoid. Replace defective item.

10. Excessive Compressor Oil Temperature:

Ambient Temp. > 125°F (52°C)
Out of Level > 15 degrees
Low Oil Level
Wrong Lube Oil
Dirty Cooler
Dirty Operating Conditions
Clogged Oil Filter Elements
Loose or Broken Belts
Operating Pressure Too High
Recirculation Of Cooling Air
Malfunctioning Thermostat
Malfunctioning Fan
Defective Oil Cooler Relief Valve
Defective Minimum Pressure Valve
Blocked or Restricted Oil Lines
Airend Malfunctioning

Corrective Action

Above spec limit.
Relocate or reposition unit.
Add oil. Look for any leaks.
Check spec in this manual.
Clean exterior surfaces.
Move unit to cleaner environment.
Replace elements. Change oil.
Tighten or replace belt set.
Reduce pressure to spec.
Close side doors. Replace belly pan.
Replace thermostat in bypass valve.
Check fan belt tension. Tighten or replace belt set.
Replace valve.
Repair or replace valve.
Clean by flushing or replace.
See Complaint 11, 12, 13, 15, 16 or 18.

11. Engine RPM Down:

Clogged Fuel Filter

Operating Pressure Too High
Incorrect Pressure Regulator Adjustment
Malfunctioning Pressure Regulator
Incorrect Linkage Adjustment
Dirty Air Filter
Malfunctioning Air Cylinder
Wrong Air Filter Element
Defective Separator Element
Engine Malfunctioning
Airend Malfunctioning

Clean primary filter. Replace final filter. Drain tanks.
Add CLEAN fuel.
Reduce pressure to spec limit.
See Section 6 in this manual.
Replace regulator.
See Section 6 in this manual.
Clean or replace elements.
Replace air cylinder and adjust per Section 6.
Install correct element.
Install new element per page 21.
See Trouble Shooting in Engine Manual.
Refer to Airend Rebuild Manual.

12. Excessive Vibration:

Rubber Mounts, Loose or Damaged
Defective Fan
Drive Coupling Defective
Engine Malfunctioning
Airend Malfunctioning
Anti-rumble valve not working.
Engine idle speed too low.

Tighten or replace.
Replace fan.
Replace coupling.
See Trouble Shooting in Engine Manual.
See Complaint 15 and 17.
Repair or Replace.
Raise "No Load" speed per Section 6.

13. Low CFM:

Dirty Air Filter
Incorrect Linkage Adjustment
Incorrect Pressure Regulator Adjustment
Malfunctioning Pressure Regulator
Malfunctioning Inlet Unloader/Butterfly Valve
Malfunctioning Air Cylinder
Defective Minimum Pressure Valve
Defective Separator Element
Wrong Air Filter Element

Clean or replace elements.
See Section 6 in this manual.
See Section 6 in this manual.
Replace regulator.
Inspect valve. Make adjustment per Section 6.
Replace air cylinder.
Repair or replace valve.
Install new element per Page 21.
Install correct element.

14. Short Air Cleaner Life:

Dirty Operating Conditions
Inadequate Element Cleaning
Incorrect Stopping Procedure
Wrong Air Filter Element
Oil Pump Drive Coupling

Corrective Action

Move unit to cleaner environment.
Install new element.
Read procedure in this manual.
Install proper element.
Inspect coupling. If necessary, replace coupling.

15. Excessive Oil In Air:

High Oil Level
Out of Level > 15 degrees
Clogged Scavenge Orifice
Scavenge Tube Blocked
Defective Scavenge Check Valve
Sep. Tank Blow Down Too Quickly
Defective Minimum Pressure Valve

Read procedure in this manual.
Relocate or reposition unit.
Remove scavenge orifice. Clean and Replace.
Remove scavenge tube. Clean and Replace.
Remove check valve. Replace with new valve.
Allow unit to blow down automatically.
Remove valve. Repair valve and replace.

16. Oil Seal Leak:

Contaminated Lube Oil
Blocked or Restricted Oil Line(s)
Malfunctioning Seal
Scored Shaft

Drain and flush system. Add new CLEAN oil.
Remove, clean and replace line(s).
Refer to Airend Rebuild Manual.
See instructions in new seal kit.

17. Will Not Unload:

Leak in Regulator Piping
Incorrect Pressure Regulator Adjustment
Malfunctioning Pressure Regulator
Malfunctioning Inlet Butterfly Valve
Ice in Regulation Lines/Orifice

Find and repair leak(s).
Refer to Section 6 in this manual.
Replace regulator.
Inspect valve fit. Readjust per Section 6.
Apply heat to line(s) and or orifice.

18. Oil In Air Cleaner:

Incorrect Stopping Procedure
Oil Pump Drive Coupling
Discharge Check Valve Faulty

Read Procedure in this manual.
Inspect coupling. Replace if necessary.
Replace.

19. Safety Valve Relieves:

Operating Pressure Too High
Leak In Regulator Piping
Incorrect Pressure Regulator Adjustment
Malfunctioning Pressure Regulator
Malfunctioning Inlet Unloader/Butterfly Valve
Defective Safety Valve
Defective Separator Element
Ice in Regulation Lines/Orifice

Reduce pressure to spec limit.
Repair leak(s).
Refer to Section 6 in this manual.
Replace regulator.
Inspect valve fit. Readjust per Section 6.
Replace safety valve.
Remove element. Install new.
Apply heat to lines and/or orifice.

SECTION 9 - PARTS ORDERING

GENERAL

This publication, which contains an illustrated parts breakdown, has been prepared as an aid in locating those parts which may be required in the maintenance of the unit. All of the compressor parts, listed in the parts breakdown, are manufactured with the same precision as the original equipment. For the greatest protection always insist on genuine Ingersoll-Rand Company parts for your compressor.

NOTICE

Ingersoll-Rand Company can bear no responsibility for injury or damages resulting directly from the use of non-approved repair parts.

Ingersoll-Rand Company service facilities and parts are available worldwide. There are Ingersoll-Rand Company Construction Equipment Group Sales Offices and authorized distributors located in the principal cities of the United States. In Canada our customers are serviced by the Canadian Ingersoll-Rand Company, Limited. There are also Ingersoll-Rand International autonomous companies and authorized distributors located in the principal cities throughout the free world.

Special order parts may not be included in this manual. Contact the Mocksville Parts Department with the unit serial number for assistance with these special parts.

DESCRIPTION

The illustrated parts breakdown illustrates and lists the various assemblies, subassemblies and detailed parts which make up this particular machine. This covers the standard models and the more popular options that are available.

A series of illustrations show each part distinctly and in

location relative to the other parts in the assembly. The part number, the description of the part and the quantity of parts required are shown on each illustration or on adjacent page. The quantities specified are the number of parts used per one assembly and are not necessarily the total number of parts used in the machine. Where no quantity is specified the quantity is assumed to be one.

Each description of a part is based upon the "noun first" method, i.e., the identifying noun or item name is always the first part of the description. The noun name is generally followed by a single descriptive modifier. The descriptive modifier may be followed by words or abbreviations such as upper, lower, inner, outer, front, rear, RH, LH, etc. when they are essential.

In referring to the rear, the front or to either side of the unit, always consider the **drawbar end** of the unit as the **front**. Standing at the rear of the unit facing the drawbar (front) will determine the right and left sides.

FASTENERS

Both SAE/inch and ISO/metric hardware have been used in the design and assembly of these units. In the disassembly and reassembly of parts, extreme care must be taken to avoid damaging threads by the use of wrong fasteners. In order to clarify the proper usage and for exact replacement parts, all standard fasteners have been identified by part number, size and description. This will enable a customer to obtain fasteners locally rather than ordering from the factory. These parts are identified in tables that will be found at the rear of the parts illustrations. Any fastener that has not been identified by both part number and size is a specially engineered part that must be ordered by part number to obtain the exact replacement part.

MARKINGS AND DECALS

NOTICE

Do not paint over safety warnings or instructional decals. If safety warning decals become illegible, immediately order replacements from the factory.

Part numbers for original individual decals and their mounting locations are shown within Parts List Section. These are available as long as a particular model is in production.

Afterwards, service sets of exterior decals and current production safety warning decals are available. Contact the Product Support Group at Mocksville for your particular needs and availability.

HOW TO USE PARTS LIST

- a. Turn to Parts List.
- b. Locate the area or system of the compressor in which the desired part is used and find illustration page number.
- c. Locate the desired part on the illustration by visual identification and make note of part number and description.

HOW TO ORDER

The satisfactory ordering of parts by a purchaser is greatly dependent upon the proper use of all available information. By supplying your nearest sales office, autonomous company or authorized distributor, with complete information, you will enable them to fill your order correctly and to avoid any unnecessary delays.

In order that all avoidable errors may be eliminated, the following instructions are offered as a guide to the purchaser when ordering replacement parts:

- a. Always specify the model number of the unit as shown on the general data decal attached to the unit.
- b. Always specify the serial number of the unit. **THIS IS IMPORTANT.** The serial number of the unit will be found stamped on a plate attached to the unit. (The serial number on the unit is also permanently stamped in the metal of the frame side rail.)

- c. Always specify the number of the parts list publication.
- d. Always specify the quantity of parts required.
- e. Always specify the part number, as well as the description of the part, or parts, exactly as it is given on the parts list illustration.

In the event parts are being returned to your nearest sales office, autonomous company or authorized distributor, for inspection or repair, it is important to include the serial number of the unit from which the parts were removed.

TERMS AND CONDITIONS ON PARTS ORDERS

Acceptance: Acceptance of an offer is expressly limited to the exact terms contained herein. If purchaser's order form is used for acceptance of an offer, it is expressly understood and agreed that the terms and conditions of such order form shall not apply unless expressly agreed to by Ingersoll-Rand Company ("Company") in writing. No additional or contrary terms will be binding upon the Company unless expressly agreed to in writing.

Taxes: Any tax or other governmental charge now or hereafter levied upon the production, sale, use or shipment of material and equipment ordered or sold is not included in the Company's price and will be charged to and paid for by the Purchaser.

Shipping dates shall be extended for delays due to acts of God, acts of Purchaser, acts of Government, fires, floods, strikes, riot, war, embargo, transportation shortages, delay or default on the part of the Company's vendors, or any other cause beyond the Company's reasonable control.

Should Purchaser request special shipping instruction, such as exclusive use of shipping facilities, including air freight when common carrier has been quoted and before change order to purchase order can be received by the Company, the additional charges will be honored by the Purchaser.

Warranty: The Company warrants that parts manufactured by it will be as specified and will be free from defects in materials and workmanship. The Company's liability under this warranty shall be limited to the repair or replacement of any part which was defective at the time of shipment provided Purchaser notifies the Company of any such defect promptly upon discovery, but in no event later than three (3) months from the date of shipment of such part by the Company. The only exception to the previous statement is the extended warranty as it applies to the special airend exchange program.

Repairs and replacements shall be made by the Company F.O.B. point of shipment. The Company shall not be responsible for costs of transportation, removal or installation.

Warranties applicable to material and equipment supplied by the Company but wholly manufactured by others shall be limited to the warranties extended to the Company by the manufacturer which are able to be conveyed to the Purchaser.

Delivery: Shipping dates are approximate. The Company will use best efforts to ship by the dates specified; however, the Company shall not be liable for any delay or failure in the estimated delivery or shipment of material and equipment or for any damages suffered by reason thereof.

The company makes no other warranty or representation of any kind whatsoever, expressed or implied, except that of title, and all implied warranties, including any warranty of merchantability and fitness for a particular purpose, are hereby disclaimed.

Limitation of Liability:

The remedies of the Purchaser set forth herein are exclusive, and the total liability of the Company with respect to this order whether based on contract, warranty, negligence, indemnity, strict liability or otherwise, shall not exceed the purchase price of the part upon which such liability is based.

The Company shall in no event be liable to the Purchaser, any successors in interest or any beneficiary of this order for any consequential, incidental, indirect, special or punitive damages arising out of this order or any breach thereof, or any defect in, or failure of, or malfunction of the parts hereunder, whether based upon loss of use, lost profits or revenue, interest, lost goodwill, work stoppage, impairment of other goods, loss by reason of shutdown or non-operation, increased expenses of operation or claims of customers of Purchaser for service interruption whether or not such loss or damage is based on contract, warranty, negligence, indemnity, strict liability or otherwise.

AIREND EXCHANGE PROGRAM

Your Ingersoll-Rand Company Construction Equipment Group Sales Offices and authorized distributors as well as Ingersoll-Rand International autonomous companies and authorized distributors now have an airend exchange program to benefit portable compressor users.

On the airend exchange program the exchange price is determined by the age and condition of the airend and may be classified by one of the following categories.

Category “A”: The airend must not be over two years old and must have reusable rotor housing(s) and rotor(s).

Category “B”: The airend must be between two and five years old and returned with two or more reusable major castings.

Category “C”: The airend must be over five years old.

Your nearest sales office, autonomous company or authorized distributor must first contact the Parts Service Department at the factory at which your portable air compressor was manufactured for an airend exchange number. The airend must be tagged with this preassigned number and returned to the factory pre-paid. The airend must be intact, with no excluded parts, otherwise the exchange agreement may be cancelled. The warranty on an exchange or factory rebuilt airend is 365 days.

Airends being returned to the factory in connection with a WARRANTY CLAIM must be processed through the Customer Service Department. If returned without a Warranty MRR (Material Return Request) Number, no warranty claim will be considered.

PARTS LIST

CONTENTS

Frame Complete
Engine Complete
Cooling Complete
Oil By-pass Vlv Complete
Airend Complete
Airend Assembly
Air Service Complete
Seperator Tank Complete
Central Drains
Air Intake Complete
Air Cleaner Assembly
Fuel Tank Complete
Remote Filters Complete
Air and Oil Piping
Air and Oil Piping
Instrument Panel
Battery Assembly
Wiring Diagram
Enclosure Complete
Acoustic Panels
Decal Location

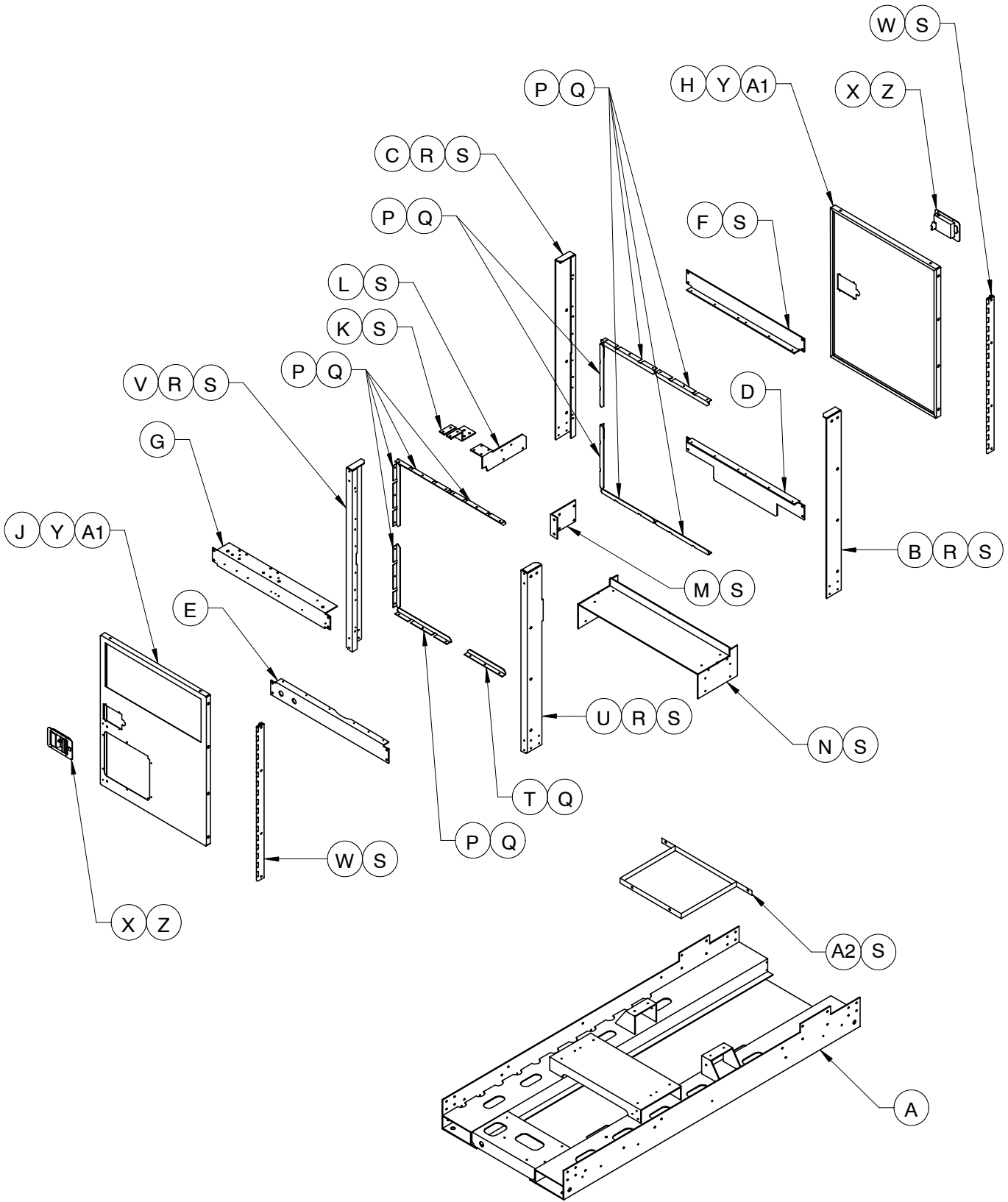

INGERSOLL-RAND COMPANY		
PORTABLE COMPRESSOR DIVISION		
DATE/DWN BY:	DESCRIPTION	
4/25/97	bc	FRAME COMPLETE
MODEL NO.	MANUAL NO.	DATE/REV:
P-130AWJDU - P-185AWJDU	35393065-02	4/98 B

ITEM	C.P.N.	QTY	DESCRIPTION
A	36890457	1	FRAME
B	36890499	1	CORNER, VERT CURB CAB
C	36890507	1	CORNER, VERT CURB BED
D	36890564	1	FRAME, DOOR LOWER
E	36890556	1	FRAME, DOOR LOWER
F	36890671	1	FRAME, DOOR UPPER
G	36890663	1	FRAME, DOOR UPPER
H	36890606	1	DOOR, STREET
J	36890598	1	DOOR, CURB SIDE
K	36890630	1	BRACKET, A/E OIL FILTER
L	36890622	1	BRACKET, ENG OIL/FUEL
M	36890614	1	BRACKET, AIR FILTER MTG.
N	36890465	1	BRIDGE, COOLER
P	36890572	11	SEAL, DOOR LONG
Q	36877587	48	RIVETS, 3/16 DIA
R	36895746	8	NUTSERT, HEX M8
S	35279025	50	SCREW, TAPPING M08-125 X 20
T	36890580	1	SEAL, DOOR SHORT
U	36890515	1	CORNER, VERT STREET CAB
V	36890523	1	CORNER, VERT STREET BED
W	36891810	2	HINGE, DOOR
X	36793602	2	LATCH, SLAM DOOR
Y	36797652	8	SCREW, TAPPING M06-1.00 X 12
Z	36794816	8	RIVET, 187X 020-125
A1	36865293	14	BUMPER, RUBBER
A2	36894210	1	PAN, FUEL TANK

INGERSOLL-RAND COMPANY		
PORTABLE COMPRESSOR DIVISION		
DATE/DWN BY:	DESCRIPTION	
4/25/97 bc	FRAME COMPLETE	
MODEL NO.	MANUAL NO.	DATE/REV:
P-130AWJDU - P-185AWJDU	35393065-03	4/98 C

INSTRUMENT PANEL

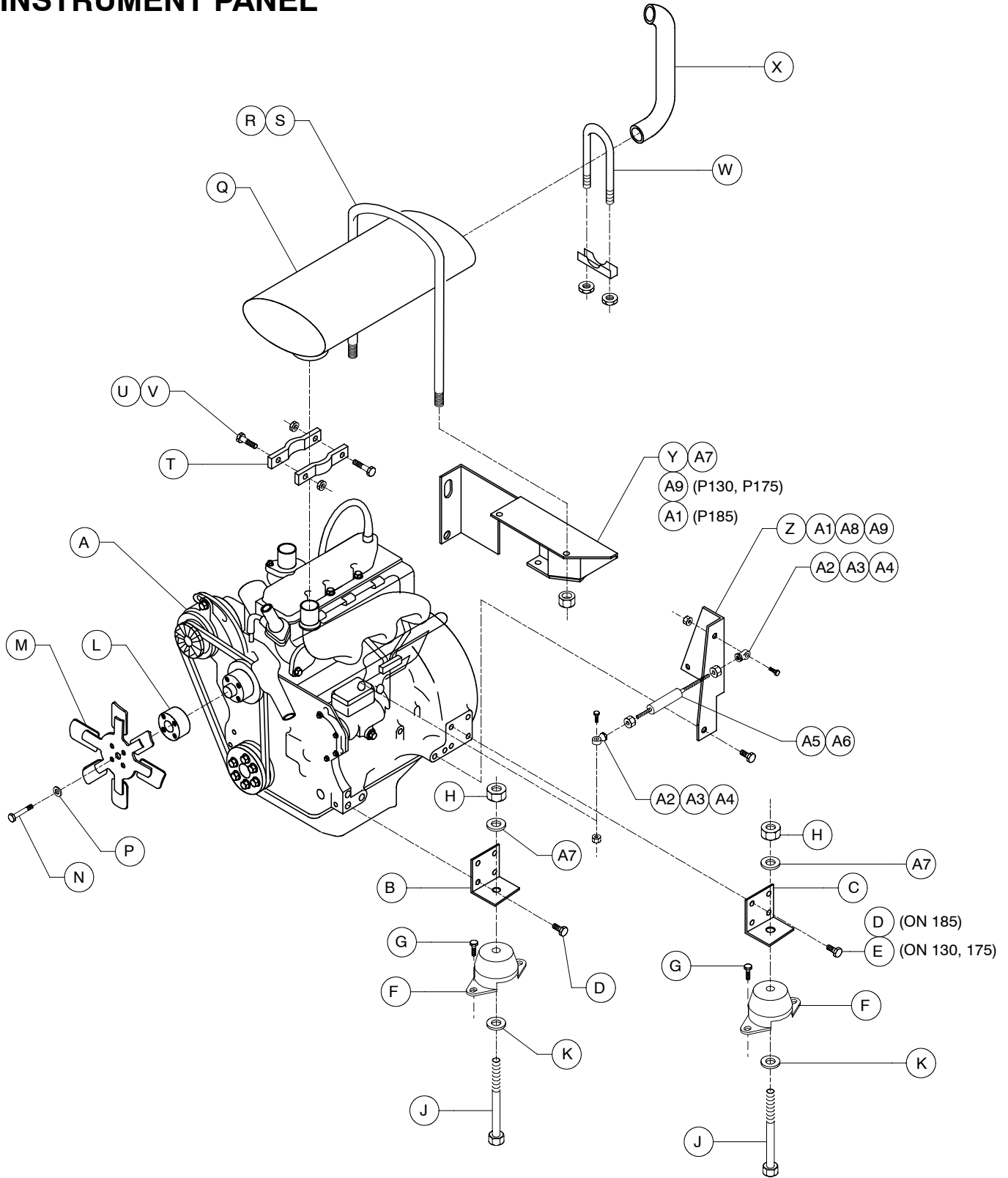

INGERSOLL-RAND COMPANY		
PORTABLE COMPRESSOR DIVISION		
DATE/DWN BY:	DESCRIPTION	
4/25/97	ENGINE COMPLETE	
MODEL NO.	MANUAL NO.	DATE/REV:
P-130AWJDU - P-185AWJDU	35393065-04	4/98 A

ITEM C.P.N. QTY DESCRIPTION

A	36889764	1	ENGINE 3 CYL. (P130, P175)	
	36889756	1	ENGINE 4 CYL. (P185)	{PRIOR TO S/N 295999}
	36920015	1	ENGINE 4 CYL. (P185)	{BEGIN WITH S/N 295999}
B	36888030	2	BRACKET, FRONT ENGINE	{PRIOR TO S/N 308296}
	54438643	2	BRACKET, FRONT ENGINE	{BEGIN WITH S/N 308296}
C	36890044	2	BRACKET, REAR ENGINE	{PRIOR TO S/N 308296}
	54444864	2	BRACKET, REAR ENGINE	{BEGIN WITH S/N 308296}
D	36888055	6	SCREW, HEX FLANGE HD M12-1.75 X 30	
E	36881712	8	SCREW, HEX FLANGE HD 1/2-13 X 1	
F	36876274	4	ISOLATOR	{PRIOR TO S/N 308296}
	54429303	4	ISOLATOR	{BEGIN WITH S/N 308296}
G	35279025	8	SCREW, TAPPING M08-1.25 X 20	
H	35273366	4	NUT, HEX NYLOCK M10	{PRIOR TO S/N 308296}
	35304047	4	NUT, HEX NYLOCK M12-1.75	{BEGIN WITH S/N 308296}
J	36766343	4	SCREW, HEX M10-1.50 X 60	{PRIOR TO S/N 308296}
	96739958	4	SCREW, HEX M12-1.75 X 70	{BEGIN WITH S/N 308296}
K	36766319	4	WASHER, SNUBBER	{PRIOR TO S/N 308296}
	54429295	4	WASHER, SNUBBER	{BEGIN WITH S/N 308296}
L	36892461	1	SPACER, 22" FAN	
M	36880649	1	FAN, 19" (P130, P175)	
	36878171	1	FAN, 22" (P185)	
N	95958955	4	SCREW, HEX 5/16-18 X 3 1/3 (P130, P175)	
	96721154	4	SCREW, HEX M08-1.25 X 90 (P185)	
P	95934998	4	WASHER, FLAT 3/8 X 7/8	
Q	36881563	1	MUFFLER	
R	35851377	1	U-BOLT 3/8-16	
S	95923322	2	NUT, HEX LOCK 3/8-16	
T	36796845	2	CLAMP, MUFFLER	
U	95935227	2	SCREW, HEX 5/16-18 X 1 1/4	
V	95929782	2	NUT, HEX 5/16-18	
W	35209048	1	CLAMP, SADDLE 2 1/2	
X	36775690	1	PIPE, EXHAUST TAIL	
Y	36880839	1	BRACKET, MUFFLER	
Z	36884864	1	SUPPORT, AIR CYLINDER (P175)	
	36877223	1	SUPPORT, AIR CYLINDER (P185)	
A1	35376953	3	SCREW, HEX M10-1.50 X 20 (P185)	
A2	35328467	2	BEARING, ROD END (P175-P185)	
A3	36771178	2	SCREW, HEX M06-1.0 X 30 (P175-P185)	
A4	36769032	2	NUT, HEX LOCK M06-1.0 (P175-P185)	
A5	35592435	1	CYLINDER, PNEUMATIC (P175-P185)	
A6	95923074	2	NUT, HEX JAM 5/16-24 (P175-P185)	
A7	95935037	4	WASHER, FLAT	{PRIOR TO S/N 308296}
	54429295	4	WASHER, FLAT	{BEGIN WITH S/N 308296}
A8	95958807	1	SCREW, HEX 5/8-12 X 1 (P175)	
A9	35144336	2	SCREW, LOCKING 5/16-18 X 3/4 (P175)	

ENGINE OIL FILTER ELEMENT 36881696
ENGINE FUEL FILTER ELEMENT 35389527 (P130 - P175)
ENGINE FUEL FILTER ELEMENT 36534659 (P185)

{PRIOR TO S/N 295999}
 {BEGIN WITH S/N 295999}

INGERSOLL-RAND COMPANY		
PORTABLE COMPRESSOR DIVISION		
DATE/DWN BY:	DESCRIPTION	
4/25/97 bc	ENGINE COMPLETE	
MODEL NO.	MANUAL NO.	DATE/REV:
P-130AWJDU - P-185AWJDU	35393065-05	4/00 D

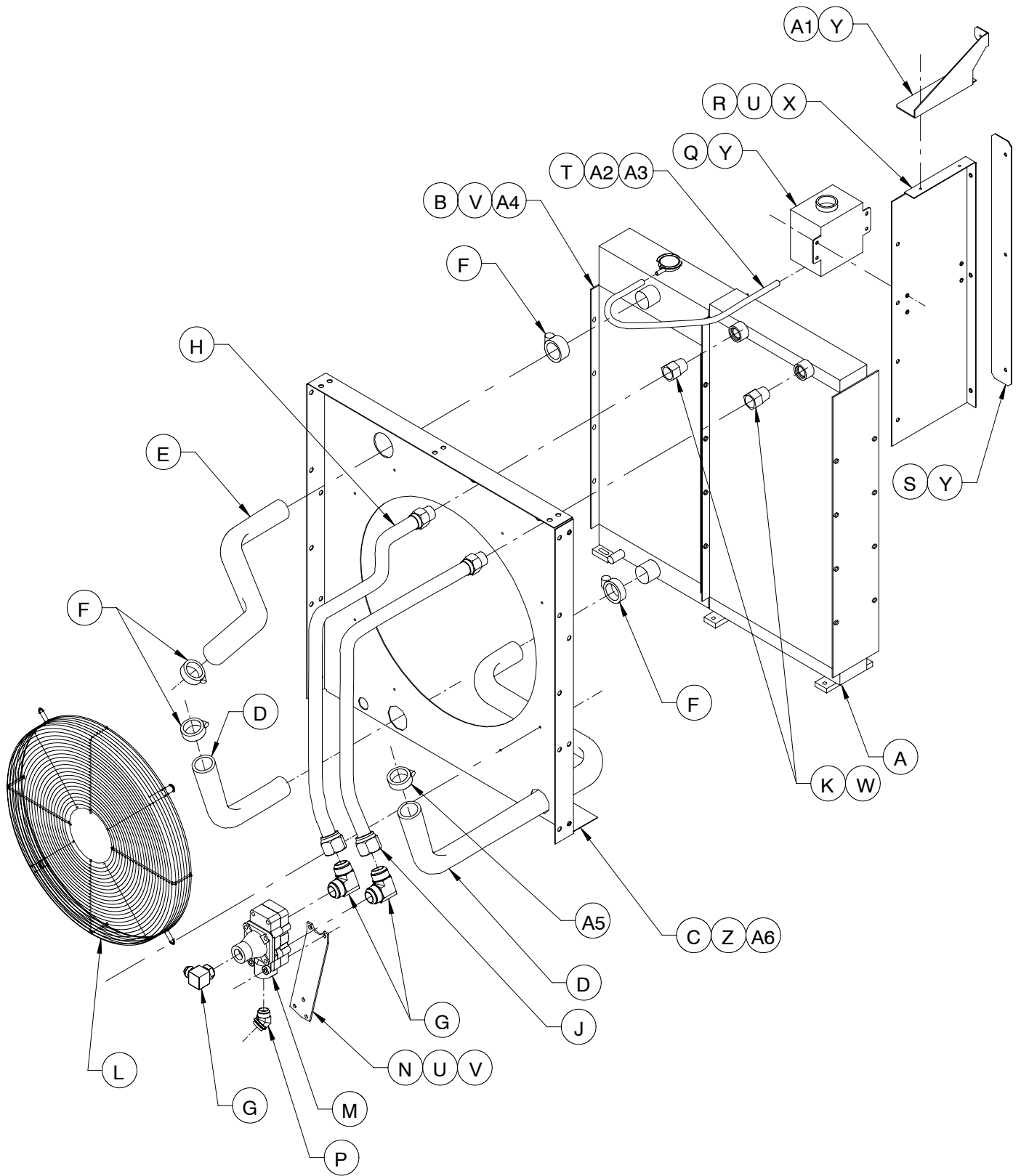

INGERSOLL-RAND COMPANY		
PORTABLE COMPRESSOR DIVISION		
DATE/DWN BY:	DESCRIPTION	
5/09/97 bc	COOLING COMPLETE	
MODEL NO.	MANUAL NO.	DATE/REV:
P-130AWJDU - P-185AWJDU	35393065-06	4/98 C

ITEM	C.P.N.	QTY	DESCRIPTION
A	36889780	1	COOLER, OIL
B	36889772	1	RADIATOR
C	36892040	1	ORIFICE, FAN (P130, P175)
	36890473	1	ORIFICE, FAN (P185)
D	36891174	1	HOSE, RADIATOR BOTTOM (P130, P175)
	36891158	1	HOSE, RADIATOR BOTTOM (P185)
E	36891166	1	HOSE, RADIATOR TOP (P130, P175)
	36891141	1	HOSE, RADIATOR TOP (P185)
F	35221662	4	CLAMP
G	35294750	3	ELBOW, 1.06-12
H	36891133	1	TUBE, OIL
J	36891091	1	TUBE, OIL
K	35295880	2	CONNECTOR, 1.06-12
L	36884096	1	GUARD, FAN (P130, P175)
	36878262	1	GUARD, FAN (P185)
M	36884179	1	VALVE, OIL BY-PASS
N	36890481	1	BRACKET, OIL BYPASS
P	35294727	1	ELBOW, 45°
Q	36884948	1	BATTLE, COOLANT RECOVERY
R	36890788	1	PANEL, PLENUM SPLITTER
S	36891570	1	COVER, PLENUM SPLITTER
T	35360775	38"	TUBING, 5/16"
U	36881886	10	NUT, HEX FLANGE M08-1.25
V	35279025	7	SCREW, TAPPING M08-1.25 X 20
W	35294768	2	O-RING
X	96702055	8	SCREW, HEX M08-1.25 X 20
Y	36797652	6	SCREW, TAPPING M06-1.00 X 14
Z	36895746	19	NUTSERT, HEX M08
A1	36890820	1	CAP, PLENUM SPLITTER
A2	35296342	1	CLAMP, WORMGEAR
A3	35225093	1	CLAMP, 1/2" RUBBER COATED
A4	36769560	1	CAP, RADIATOR
A5	35221639	1	CLAMP, HOSE (P185)
A6	36878221	2	GROMMET, RADIATOR HOSE

INGERSOLL-RAND COMPANY		
PORTABLE COMPRESSOR DIVISION		
DATE/DWN BY:	DESCRIPTION	
5/09/97 bc	COOLING COMPLETE	
MODEL NO.	MANUAL NO.	DATE/REV:
P-130AWJDU - P-185AWJDU	35393065-07	4/98 C

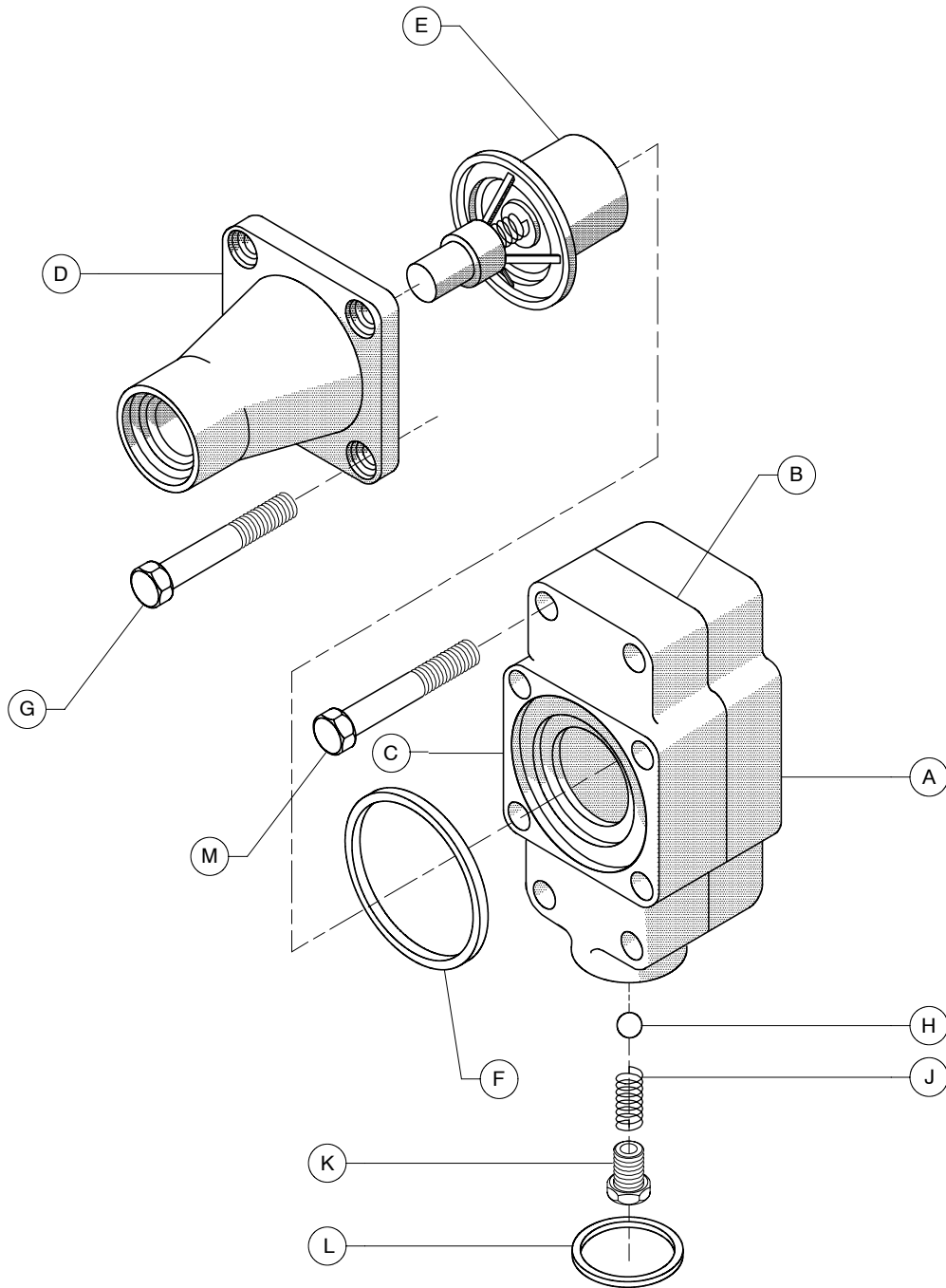

**OIL TEMPERATURE BYPASS VALVE
ASSEMBLY 36884179**

INGERSOLL-RAND COMPANY		
PORTABLE COMPRESSOR DIVISION		
DATE/DWN BY:	DESCRIPTION	
5/09/97	bc	OIL TEMP BYPASS VALVE
MODEL NO.	MANUAL NO.	DATE/REV:
P-130WJDU P-185WJDU	35393065-08	4/98 A

ITEM	C.P.N.	QTY	DESCRIPTION
A	36776714	1	BODY
B	35584242	1	GASKET
C	36788289	1	BODY
D	36765832	1	COVER
E	36782019	1	ELEMENT
F	95022307	1	O-RING
G	36786382	6	SCREW
H	35288448	1	BALL
J	35379940	1	SPRING
K	36788164	1	PLUG
L	36788172	1	SEAL
M	36884187	2	SCREW, HEX M08-125 X 80

**OIL TEMPERATURE BYPASS VALVE
ASSEMBLY 36884179**

INGERSOLL-RAND COMPANY		
PORTABLE COMPRESSOR DIVISION		
DATE/DWN BY:	DESCRIPTION	
5/09/97 bc	OIL TEMP BYPASS VALVE	
MODEL NO.	MANUAL NO.	DATE/REV:
P-130WJDU P-185WJDU	35393065-09	4/98 A

← FRONT

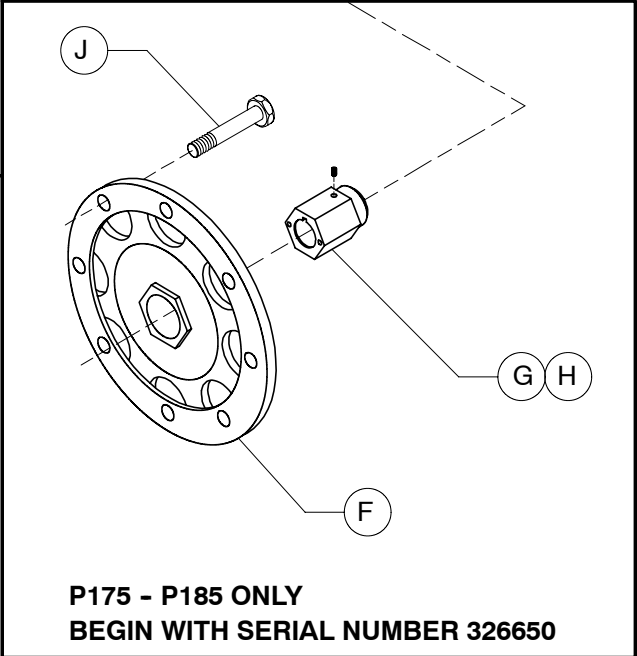
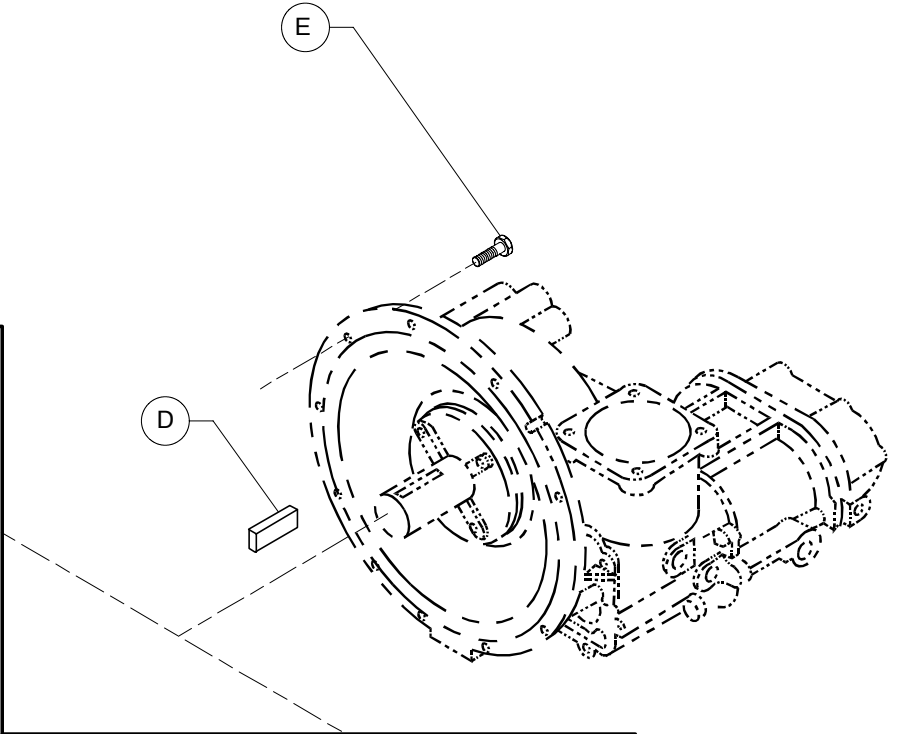
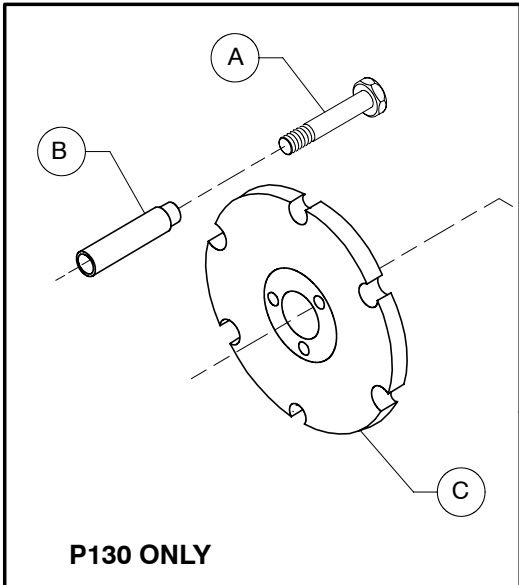

INGERSOLL-RAND COMPANY		
PORTABLE COMPRESSOR DIVISION		
DATE/DWN BY:	DESCRIPTION	
6/18/96	bc	AIREND COMPLETE
MODEL NO.	MANUAL NO.	DATE/REV:
	35393065-10	2/02 C

ITEM	C.P.N.	QTY	DESCRIPTION
A	95055307	8	SCREW, CAP SOC HD 3/8-16 X 2
B	35329887	8	DRIVER, COUPLING 3/8
C	36865012	1	COUPLING, DRIVE
D	36769289	1	KEY
E	36880995	9	SCREW, HEX FLANGE HD M10-1.5 X 30
F	54755087	1	COUPLING
G	54755111	1	BEARING, HEX
H	95065637	1	SCREW, SOCKET SET 3/8-16 X 1/4
J	36881704	8	SCREW, HEX FLANGE HD 3/8-16 X 1.25

INGERSOLL-RAND COMPANY		
PORTABLE COMPRESSOR DIVISION		
DATE/DWN BY:	DESCRIPTION	
6/18/96	bd	AIREND COMPLETE
MODEL NO.	MANUAL NO.	DATE/REV:
	35393065-11	2/02 C

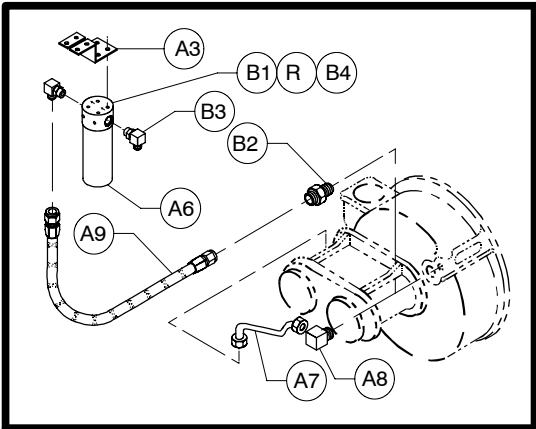

DRAWBAR END

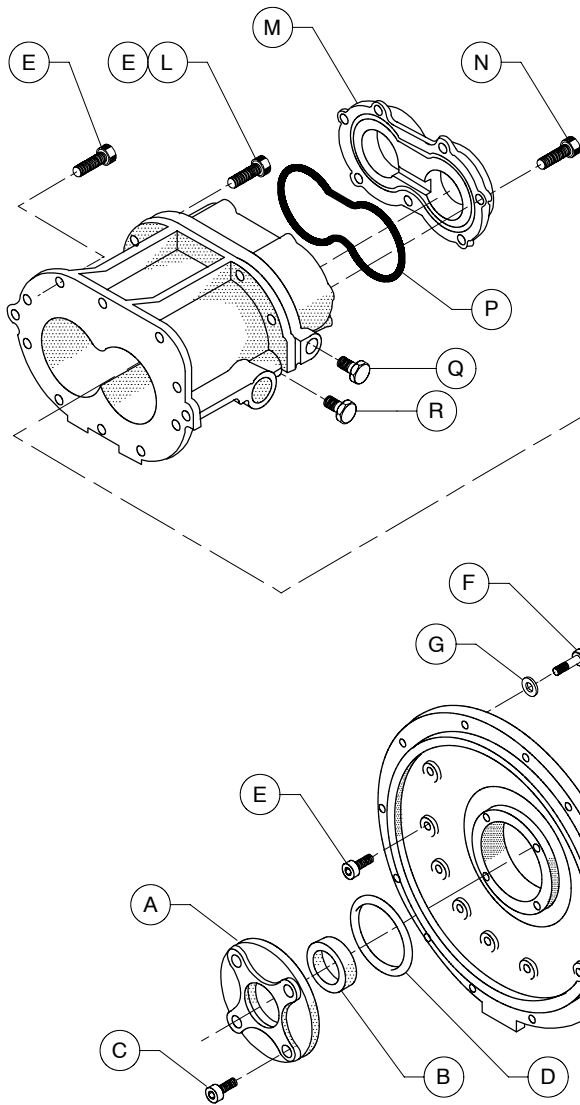
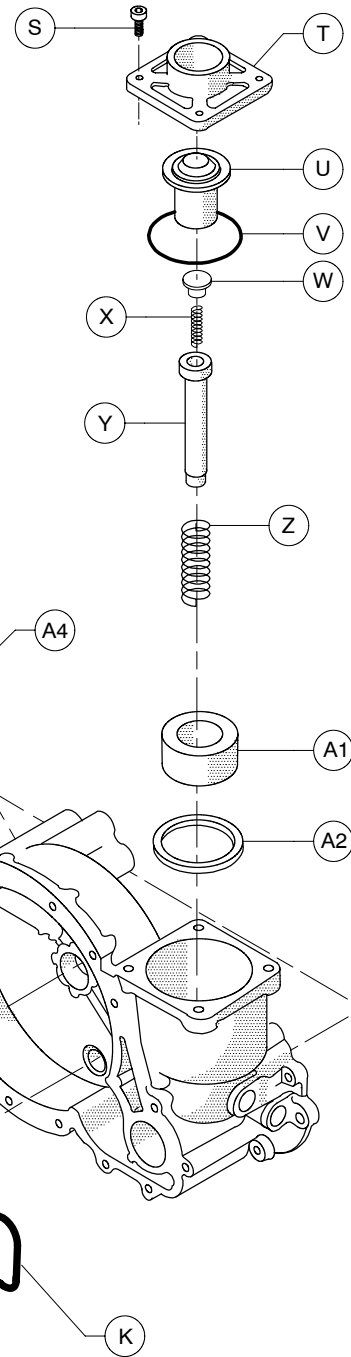

- * NEW P-130 AIREND ASSEMBLY 42430918
- * NEW P-175 AIREND ASSEMBLY 42430926
- * NEW P-185 AIREND ASSEMBLY 42430926

INGERSOLL-RAND COMPANY		
PORTABLE COMPRESSOR DIVISION		
DATE/DWN BY:	DESCRIPTION	
5/09/97	bc	AIREND ASSEMBLY
MODEL NO.	MANUAL NO.	DATE/REV:
P130WJDU P185WJDU	35393065-12	4/98 A

ITEM	C.P.N.	QTY	DESCRIPTION
A	39588413	1	SEAL COVER
B	35375369	1	SEAL
C	35611961	4	SCREW
D	95022331	1	O-RING
E	96708060	32	SCREW
F	36791689	2	SCREW
G	95094306	2	WASHER
H	35286004	1	BEARING
J	39101449	1	PLUG
K	95641734	1	O-RING
L	35612134	1	SCREW
M	36506442	1	BEARING COVER
N	35611953	7	SCREW
P	95023115	1	O-RING
Q	35289057	1	PLUG
R	35287556	3	PLUG, HEX 5/16-18
S	35287655	4	SCREW
T	36508471	1	INLET COVER
U	36511623	1	UNLOADER VALVE
V	90523107	1	O-RING
W	35379817	1	SPRING CAP
X	35376342	1	SPRING
Y	35611557	1	STEM
Z	35376334	1	SPRING
A1	35611615	1	PISTON
A2	35376359	1	SEAL
A3	36890630	1	BRACKET, A/E OIL FILTER
A4	35612175	1	CONNECTOR
A5	95257333	1	CAP
A6	36897353	1	ELEMENT, FILTER
A7	36764553	1	TUBE ASSY
A8	35286491	2	ELBOW
A9	35289503	1	HOSE ASSEMBLY (P130, P175)
	35323864	1	HOSE ASSEMBLY (P185)
B1	35355460	1	HEAD, FILTER
	36897445	1	HEAD, FILTER
B2	35295880	1	CONNECTOR, 1.06-12 JIC (P130, P175)
	36885093	1	ELBOW, 90° LONG (P185)
B3	35294750	2	ELBOW, 1.06-12
B4	96701479	4	SCREW, HEX M10-1.50 X 16

{PRIOR TO S/N 300624}
{BEGIN WITH S/N 300624}

* NEW P-130 AIREND ASSEMBLY 42430918
* NEW P-175 AIREND ASSEMBLY 42430926
* NEW P-185 AIREND ASSEMBLY 42430926

*** EXCHANGE AIREND OPTION:** INGERSOLL-RAND OFFERS FACTORY REMANUFACTURED AIRENDS THAT ARE BUILT TO THE LATEST DESIGNS. MEANING IT WILL REFLECT ALL THE ENGINEERING UPGRADES AND PERFORMANCE ENHANCEMENTS MADE TO THAT SIZE UNIT. ALL EXCHANGE AIRENDS COME WITH A ONE YEAR WARRANTY. THESE BENEFITS MAKE A FACTORY REBUILT AIREND THE ONLY COST EFFECTIVE OPTION. CALL YOUR LOCAL IR DEALER FOR MORE DETAILS. PLEASE PROVIDE YOUR AIREND SERIAL NUMBER.

INGERSOLL-RAND COMPANY PORTABLE COMPRESSOR DIVISION		
DATE/DWN BY:	DESCRIPTION	
5/09/97	bd AIREND ASSEMBLY	
MODEL NO.	MANUAL NO.	DATE/REV:
P130WJDU P185WJDU	35393065-13	5/99 C

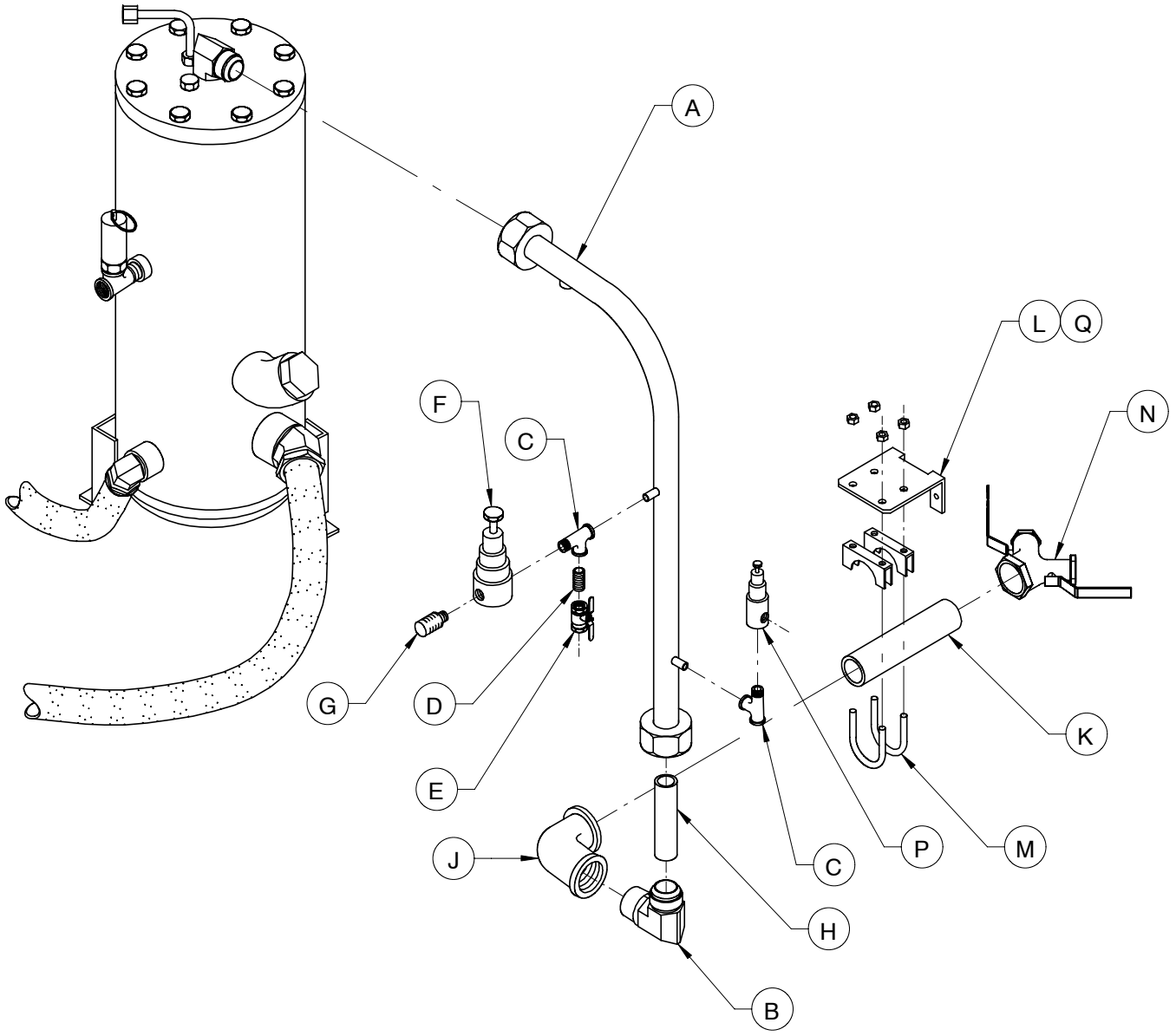

INGERSOLL-RAND COMPANY		
PORTABLE COMPRESSOR DIVISION		
DATE/DWN BY:	DESCRIPTION	
5/12/97	bc AIR SERVICE COMPLETE	
MODEL NO.	MANUAL NO.	DATE/REV:
P-130AWJDU - P-185AWJDU	35393065-14	4/98 A

ITEM	C.P.N.	QTY	DESCRIPTION	
A	36891505	1	TUBE, SERVICE	
B	95219861	1	ELBOW, TUBE	
C	35114545	2	TEE, STREET 1/4 NPT	
D	95048914	1	NIPPLE, 1/4NPT	
E	35324839	1	VALVE, BALL	
F	35322379	1	VALVE, BLOWDOWN	
G	36766772	1	ORIFICE, MUFFLER .062	
H	35608009	1	NOZZLE, .319 SONIC (P130)	{PRIOR TO S/N 305271}
	36923910	1	NOZZLE, .319 SONIC ORIFICE (P130)	{BEGIN WITH S/N 305271}
	35608025	1	NOZZLE, .378 SONIC (P175)	
	36865129	1	NOZZLE, .394 SONIC (P185)	{PRIOR TO S/N 305271}
	36921377	1	NOZZLE, .395 SONIC ORIFICE (P185)	{BEGIN WITH S/N 305271}
J	95953378	1	ELBOW, 90° 1.25	
K	95916268	1	NIPPLE, 1.25 X 8	
L	36890846	1	BRACKET, SERVICE PIPE	
M	36785277	1	CLAMP, SADDLE 1.62 Ø	
N	36881076	1	VALVE, WYE	
P	36854149	1	VALVE, PRESSURE REGULATOR	
Q	35279025	2	SCREW, TAPPING M08-1.25 X 20	

INGERSOLL-RAND COMPANY		
PORTABLE COMPRESSOR DIVISION		
DATE/DWN BY:	DESCRIPTION	
5/12/97	AIR SERVICE COMPLETE	
MODEL NO.	MANUAL NO.	DATE/REV:
P-130AWJDU - P-185AWJDU	35393065-15	11/99 B

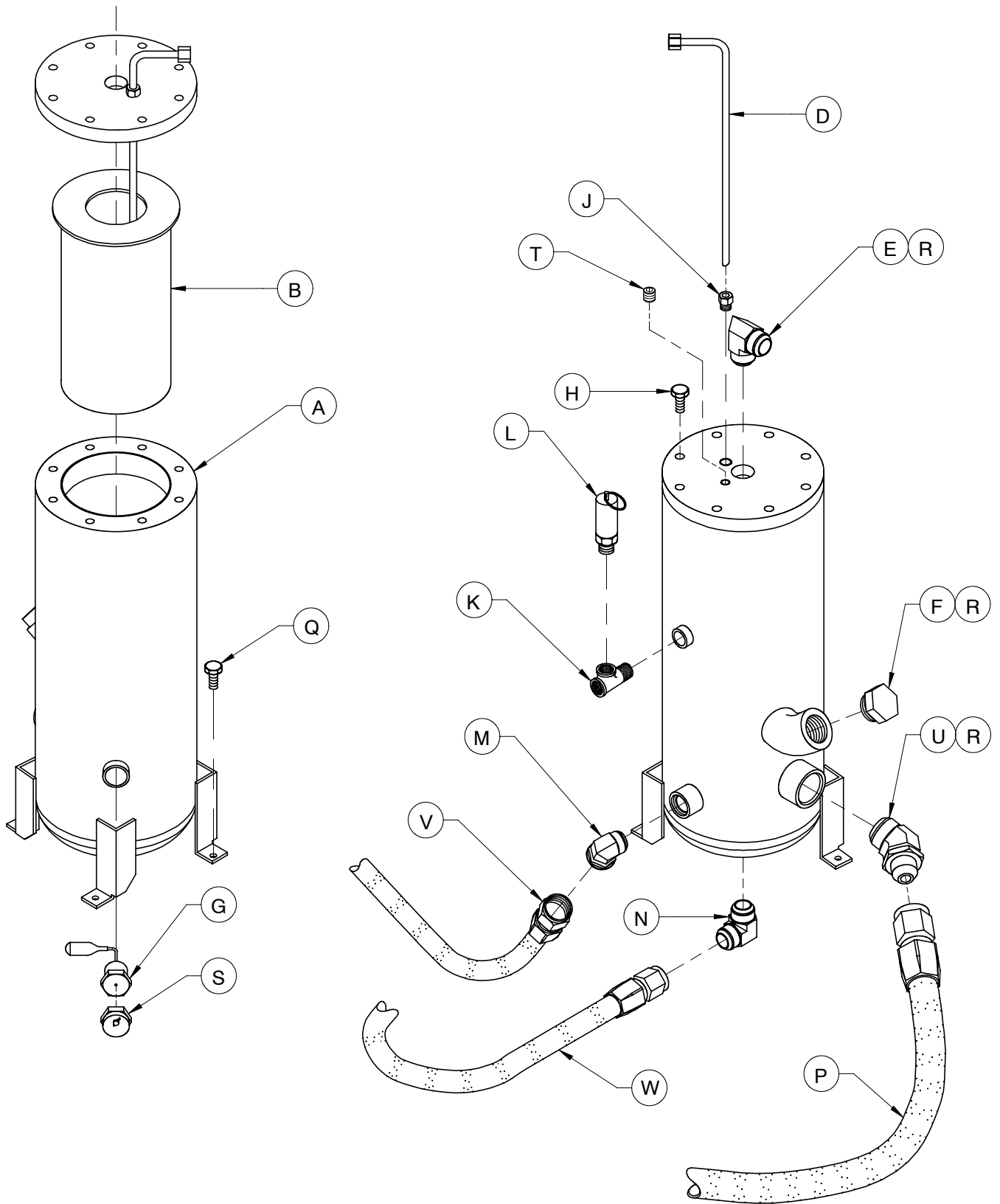

INGERSOLL-RAND COMPANY		
PORTABLE COMPRESSOR DIVISION		
DATE/DWN BY:	DESCRIPTION	
5/06/97	bc SEPARATOR TK COMPLETE	
MODEL NO.	MANUAL NO.	DATE/REV:
P-130AWJDU - P-185AWJDU	35393065-16	7/00 B

ITEM	C.P.N.	QTY	DESCRIPTION
A	54465984	1	TANK, SEPARATOR
B	36845303	1	ELEMENT, SEPARATOR
C	~	~	~
D	36781227	1	TUBE, SCAVENGE
E	35279777	1	ELBOW, 90° 1 5/8
F	35579630	1	PLUG, 1 5/8 HEX
G	36891083	1	GAGE ASSEMBLY, OIL LEVEL
H	36877793	8	SCREW, HEX M12-1.75 X 40
J	36890317	1	FITTING, SCAVENGE
K	95944708	1	TEE, STREET NPT 1/2
L	35325166	1	VALVE, SAFETY
M	35294727	1	ELBOW, 45°
N	36891059	1	ELBOW, 90° LONG
P	35121243	1	HOSE, 1 1/4 X 36
Q	35279025	3	SCREW, TAPPING M08-1.25 X 20
R	35279942	3	O-RING
S	* 36891489	1	POINTER ASSEMBLY, ROTATING
T	95252409	1	PLUG , 1/4 NPT
U	35283191	1	ELBOW, 45° 1 1/16-12
V	35287721	1	HOSE, 3/4 JIC X 17
W	35283043	1	HOSE, JIC -8 X 21

* INCLUDED WITH OIL LEVEL GAGE ASSEMBLY (36891083)

INGERSOLL-RAND COMPANY		
PORTABLE COMPRESSOR DIVISION		
DATE/DWN BY:	DESCRIPTION	
5/06/97	bd SEPARATOR TK COMPLETE	
MODEL NO.	MANUAL NO.	DATE/REV:
P-130AWJDU - P-185AWJDU	35393065-17	7/00 C

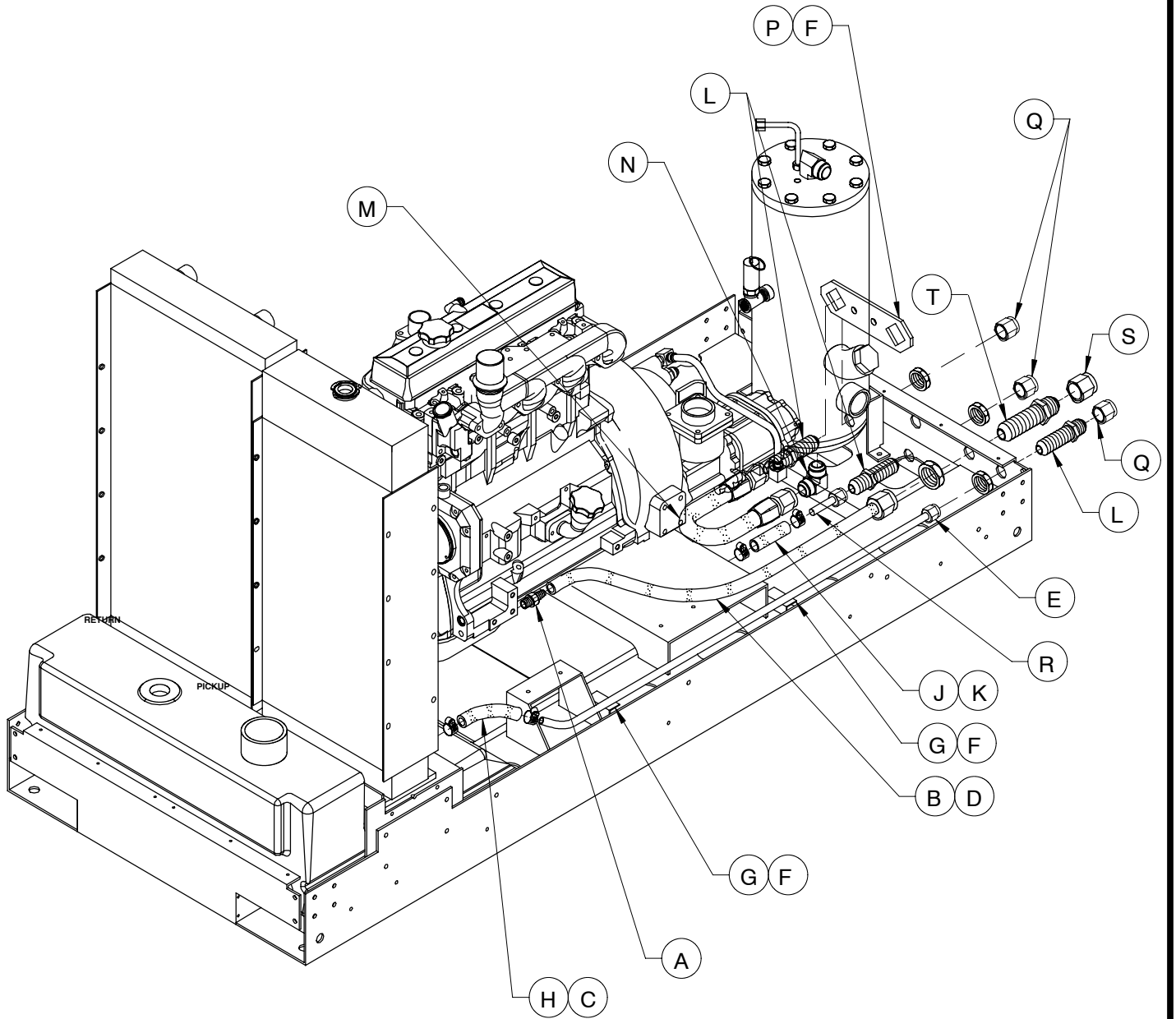

INGERSOLL-RAND COMPANY		
PORTABLE COMPRESSOR DIVISION		
DATE/DWN BY:	DESCRIPTION	
6/10/97 bc	CENTRAL DRAINS	
MODEL NO.	MANUAL NO.	DATE/REV:
P-130AWJDU - P-185AWJDU	35393065-18	4/98 A

	C.P.N.	QTY	DESCRIPTION
A	35294735	1	ELBOW, 3/4 NPT
B	35323807	1	HOSE, ENG OIL DRAIN
C	95220844	3	CLAMP, HOSE 9/16
D	35114081	1	CLAMP, HOSE 1.06
E	36891067	1	TUBE, RADIATOR DRAIN
F	35279025	6	SCREW, TAPPING M08-1.25 X 20
G	36891588	2	BRACKET, DRAIN PIPING
H	36892479	15"	HOSE, .50 ID
J	36892172	1	HOSE, DRAIN CONNECTOR
K	95220851	2	CLAMP, WORM GEAR
L	35285451	3	UNION, BULKHEAD
M	35283043	1	HOSE, JIC -8 X 21
N	36891059	1	ELBOW, 90° LONG
P	36891208	1	WRENCH, PLATE
Q	35313428	3	CAP, 3/4-16
R	36891042	1	TUBE, FUEL DRAIN
S	95730172	1	CAP, 1.06-12
T	95332599	1	CONNECTOR, BULKHEAD 1.06-12

INGERSOLL-RAND COMPANY		
PORTABLE COMPRESSOR DIVISION		
DATE/DWN BY:	DESCRIPTION	
6/10/97 bc	CENTRAL DRAINS	
MODEL NO.	MANUAL NO.	DATE/REV:
P-130AWJDU - P-185AWJDU	35393065-19	4/98 A

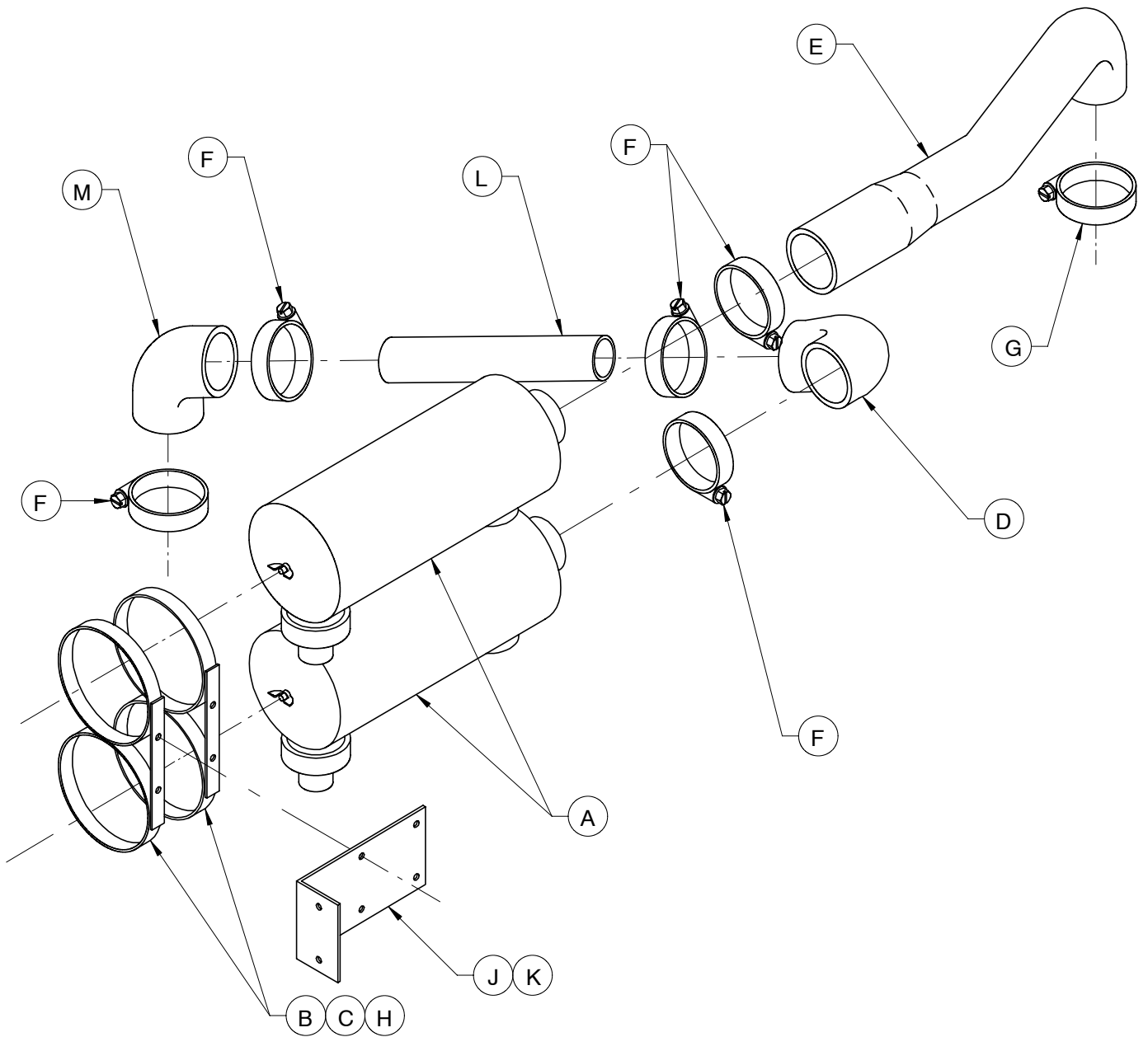

INGERSOLL-RAND COMPANY		
PORTABLE COMPRESSOR DIVISION		
DATE/DWN BY:	DESCRIPTION	
5/12/97	bd AIR INTAKE COMPLETE	
MODEL NO.	MANUAL NO.	DATE/REV:
P-130AWJDU - P-185AWJDU	35393065-20	4/98 A

ITEM	C.P.N.	QTY	DESCRIPTION
A	36862829	2	CLEANER, ASSEMBLY AIR
B	36778587	2	BAND, AIR CLEANER
C	96702048	4	SCREW, HEX M08-1.25 X 16
D	36778496	1	HOSE, AIR INTAKE
E	36891828	1	HOSE, ENGINE AIR INTAKE
F	35374073	5	CLAMP, TEE 3.62
G	35314996	1	CLAMP, TEE 3.12
H	36881886	4	NUT, HEX FLANGE M08-1.25
J	36890614	1	BRACKET, AIR FILTER MTG.
K	35279025	2	SCREW, TAPPING M08-1.25 X 20
L	35295229	1	TUBE, AIR INLET
M	36892032	1	HOSE, A/E AIR INTAKE (P130 - P175)
	36892024	1	HOSE, A/E AIR INTAKE (P185)

INGERSOLL-RAND COMPANY		
PORTABLE COMPRESSOR DIVISION		
DATE/DWN BY:	DESCRIPTION	
5/12/97	bd AIR INTAKE COMPLETE	
MODEL NO.	MANUAL NO.	DATE/REV:
P-130AWJDU - P-185AWJDU	35393065-21	4/98 A

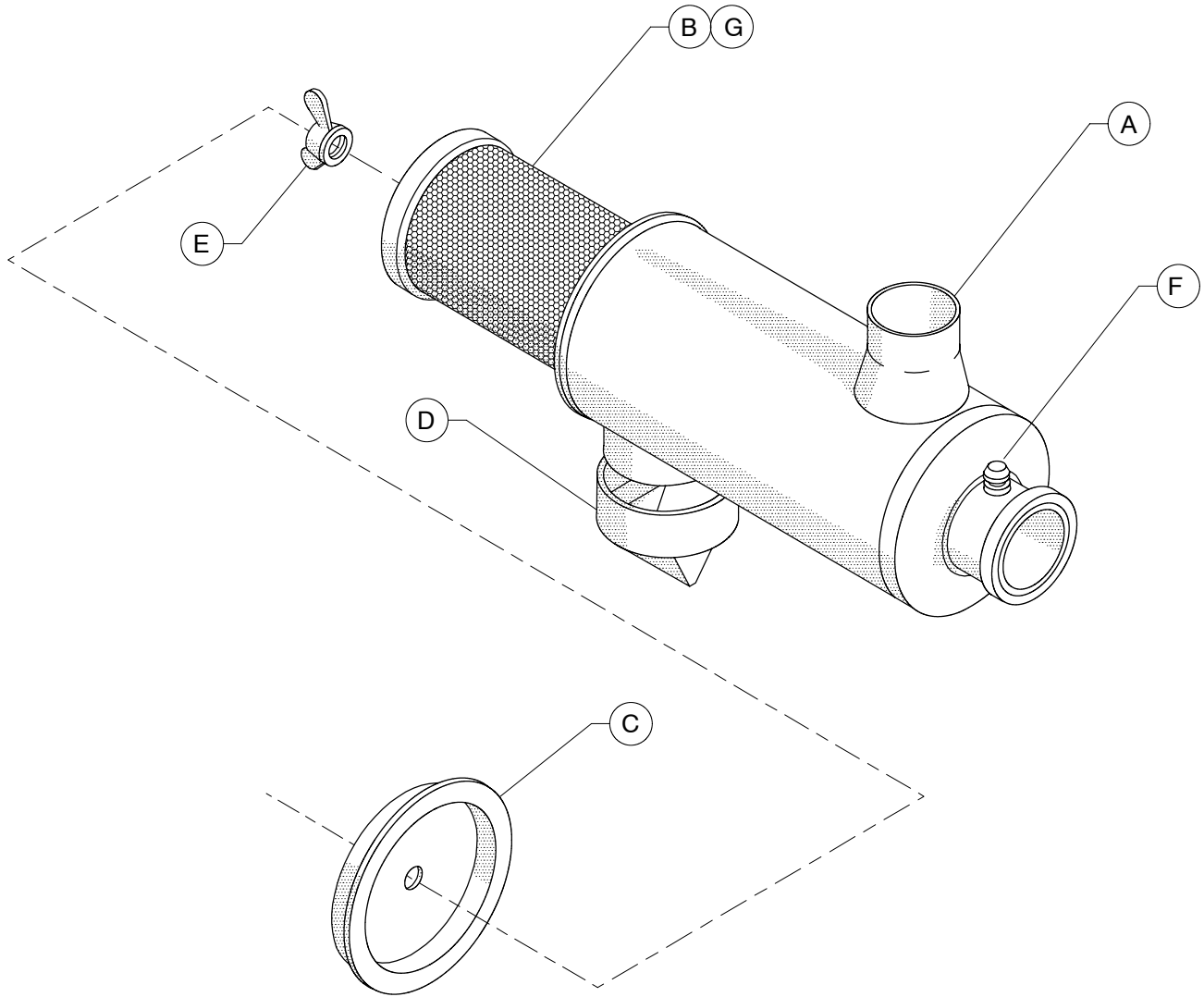

AIR CLEANER ASSEMBLY 36862829

INGERSOLL-RAND COMPANY		
PORTABLE COMPRESSOR DIVISION		
DATE/DWN BY:	DESCRIPTION	
8/19/93	bd	AIR CLEANER ASSEMBLY
MODEL NO.	MANUAL NO.	DATE/REV:
P-130BWJD P-185CWJD	35393065-22	4/98 E

ITEM	C.P.N.	QTY	DESCRIPTION
A	35388883	1	AIR CLEANER BODY
B	36876423	1	ELEMENT
C	35326032	1	COVER
D	35388891	1	VACUATOR VALVE
E	35291475	1	NUT
F	36790277	1	HEX CAP
G	35321637	1	SAFETY ELEMENT (OPTION)
	35291475	1	NUT (OPTION)

AIR CLEANER ASSEMBLY 36862829

INGERSOLL-RAND COMPANY		
PORTABLE COMPRESSOR DIVISION		
DATE/DWN BY:	DESCRIPTION	
8/19/93	bd	AIR CLEANER ASSEMBLY
MODEL NO.	MANUAL NO.	DATE/REV:
P-130BWJD P-185CWJD	35393065-23	4/98 F

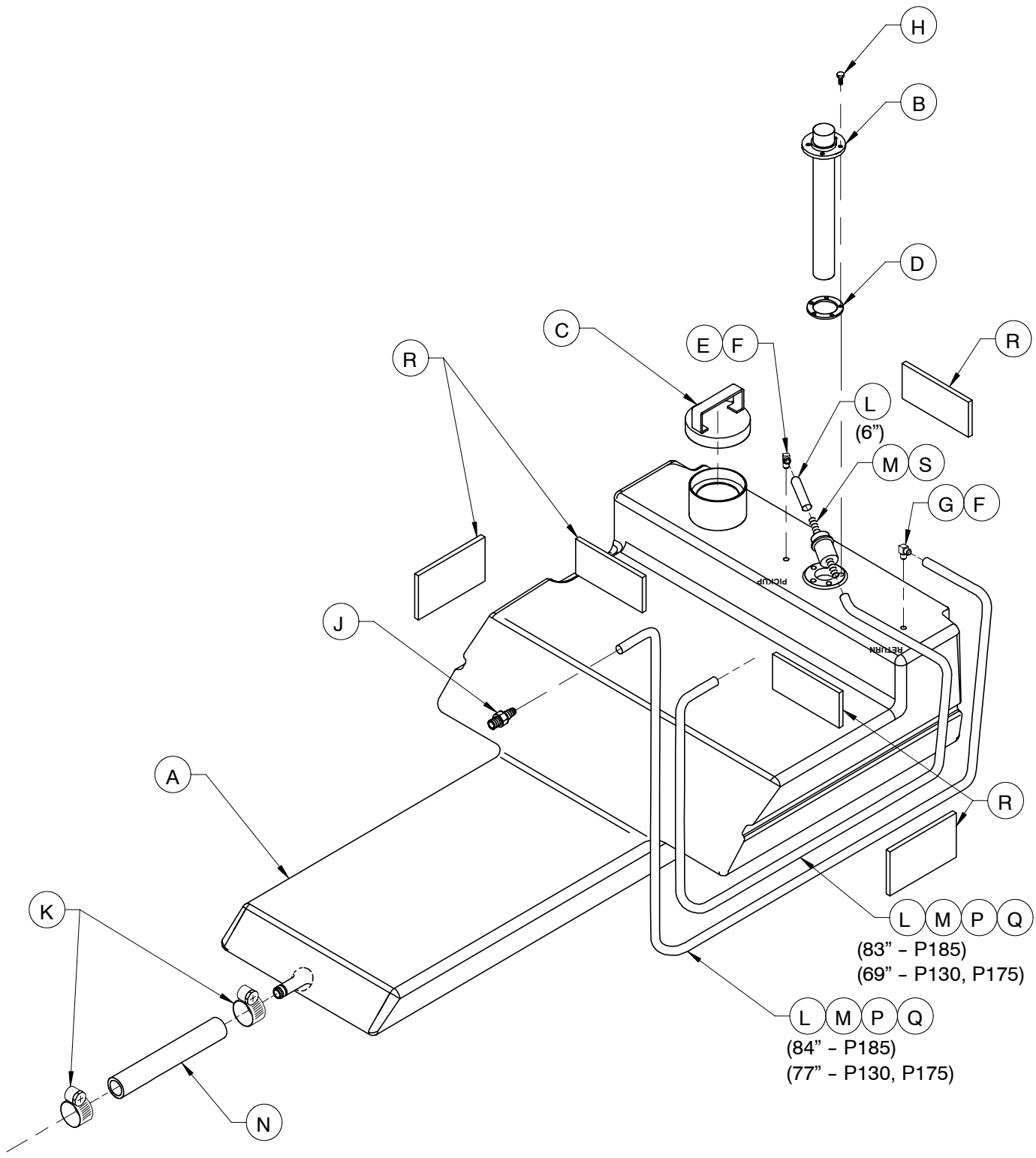

INGERSOLL-RAND COMPANY		
PORTABLE COMPRESSOR DIVISION		
DATE/DWN BY:	DESCRIPTION	
5/09/97	bc	FUEL TANK COMPLETE
MODEL NO.	MANUAL NO.	DATE/REV:
P-130AWJDU - P-185AWJDU	35393065-24	4/98 B

ITEM	C.P.N.	QTY	DESCRIPTION
A	36889939	1	TANK, FUEL
B	36890200	1	SENDER, FUEL LEVEL
C	36885564	1	CAP, FUEL
D	35361849	1	GASKET, FUEL SENDER
E	36892156	1	STANDPIPE ASSEMBLY, PICKUP
F	35384577	2	BUSHING, NITRILE
G	36892164	1	STANDPIPE ASSEMBLY, RETURN
H	95916532	5	SCREW, FILISTER SLTD HD 10-32 X .5
J	35322460	1	UNION, BARBED TUBE
K	95220851	2	CLAMP, HOSE
L	35363498	*	HOSE, FUEL .31" Ø
M	35296342	6	CLAMP, WORMGEAR
N	36892172	1	HOSE, DRAIN CONNECTOR
P	35225093	3	CLAMP, 1/2" SUPPORT
Q	35279025	1	SCREW, TAPPING M08-1.25 X 20
R	36767051	5	FOAM, CLOSED CELL
S	36845493	1	FILTER, FUEL

* SEE ILLUSTRATION FOR LENGTHS

INGERSOLL-RAND COMPANY		
PORTABLE COMPRESSOR DIVISION		
DATE/DWN BY:	DESCRIPTION	
6/25/97	bd	FUEL TANK COMPLETE
MODEL NO.	MANUAL NO.	DATE/REV:
P-130AWJDU - P-185AWJDU	35393065-25	4/98 B

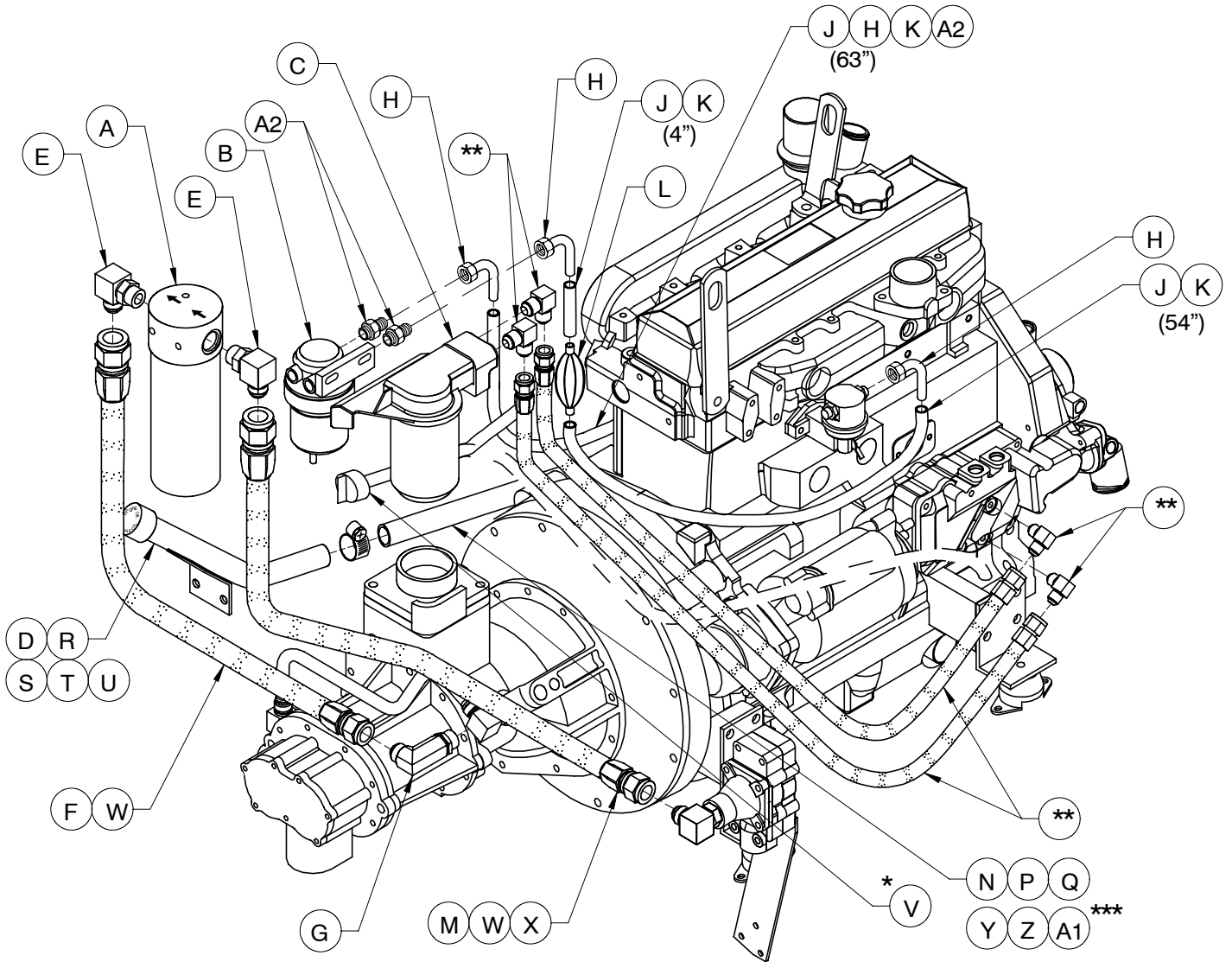

- * P185 MOUNTING SHOWN SOLID - P130, P175 MOUNTING SHOWN PHANTOM
- ** FURNISHED BY ENGINE MANUFACTURER
- *** P185 ONLY

INGERSOLL-RAND COMPANY		
PORTABLE COMPRESSOR DIVISION		
DATE/DWN BY:	DESCRIPTION	
5/14/97	bd REMOTE FILTERS COMPLETE	
MODEL NO.	MANUAL NO.	DATE/REV:
P-130AWJDU - P-185AWJDU	35393065-26	4/98 C

ITEM	C.P.N.	QTY	DESCRIPTION	
A	36739514	1	HEAD, FILTER	{PRIOR TO S/N 300624}
	36897445	1	HEAD, FILTER	{BEGIN WITH S/N 300624}
	36897353	1	ELEMENT, COMPRESSOR OIL FILTER	
B	35389527	1	ELEMENT, ENGINE FUEL FILTER	
C	36881696	1	ELEMENT, ENGINE OIL FILTER	
D	36891968	1	TUBE, OIL FILL	
E	35294750	2	ELBOW, 90° 1 1/16-12 JIC	
F	35289503	1	HOSE ASSEMBLY (P130, P175)	
	35323864	1	HOSE ASSEMBLY (P185)	
G	35295880	1	CONNECTOR, 1.06-12 JIC (P130, P175)	
	36885093	1	ELBOW, 90° LONG (P185)	
H	36889350	4	LINE, 90° FUEL	
J	35363498	*	HOSE, 5/16" FUEL	
K	35296342	6	CLAMP, WORM GEAR	
L	36889947	1	BULB, FUEL PRIMER	
M	35289503	1	HOSE ASSEMBLY	
N	36890895	1	HOSE, OIL FILL	
P	35221662	2	CLAMP, HOSE	
Q	36891117	1	ADAPTER, ENGINE OIL FILL (P130 - P175)	
	36891109	1	ADAPTER, ENGINE OIL FILL (P185)	
R	35113885	1	CLAMP, SUPPORT 1.25	
S	35376953	1	SCREW, HEX M10-1.50 X 20	
T	36879195	1	NUT, HEX FLANGE M10	
U	36877587	1	RIVET, 3/16 Ø	
V	36890176	1	DIPSTICK, REMOTE MOUNT (P130 - P175)	
	36890168	1	DIPSTICK, REMOTE MOUNT (P185)	
W	35114081	2	CLAMP, SUPPORT 1.07	
X	35300771	1	SCREW, TAPPING M06-1.0 X 20	
Y	96702055	2	SCREW, HEX M08-1.25 X 20 (P185)	
Z	95934998	2	WASHER, FLAT (P185)	
A1	36894160	1	GASKET, ENGINE OIL FILL (P185)	
A2	36895472	3	CONNECTOR, FUEL FILTER (P130 - P175)	

* SEE ILLUSTRATION FOR LENGTHS

INGERSOLL-RAND COMPANY		
PORTABLE COMPRESSOR DIVISION		
DATE/DWN BY:	DESCRIPTION	
5/14/97	bd REMOTE FILTERS COMPLETE	
MODEL NO.	MANUAL NO.	DATE/REV:
P-130AWJDU - P-185AWJDU	35393065-27	5/99 F

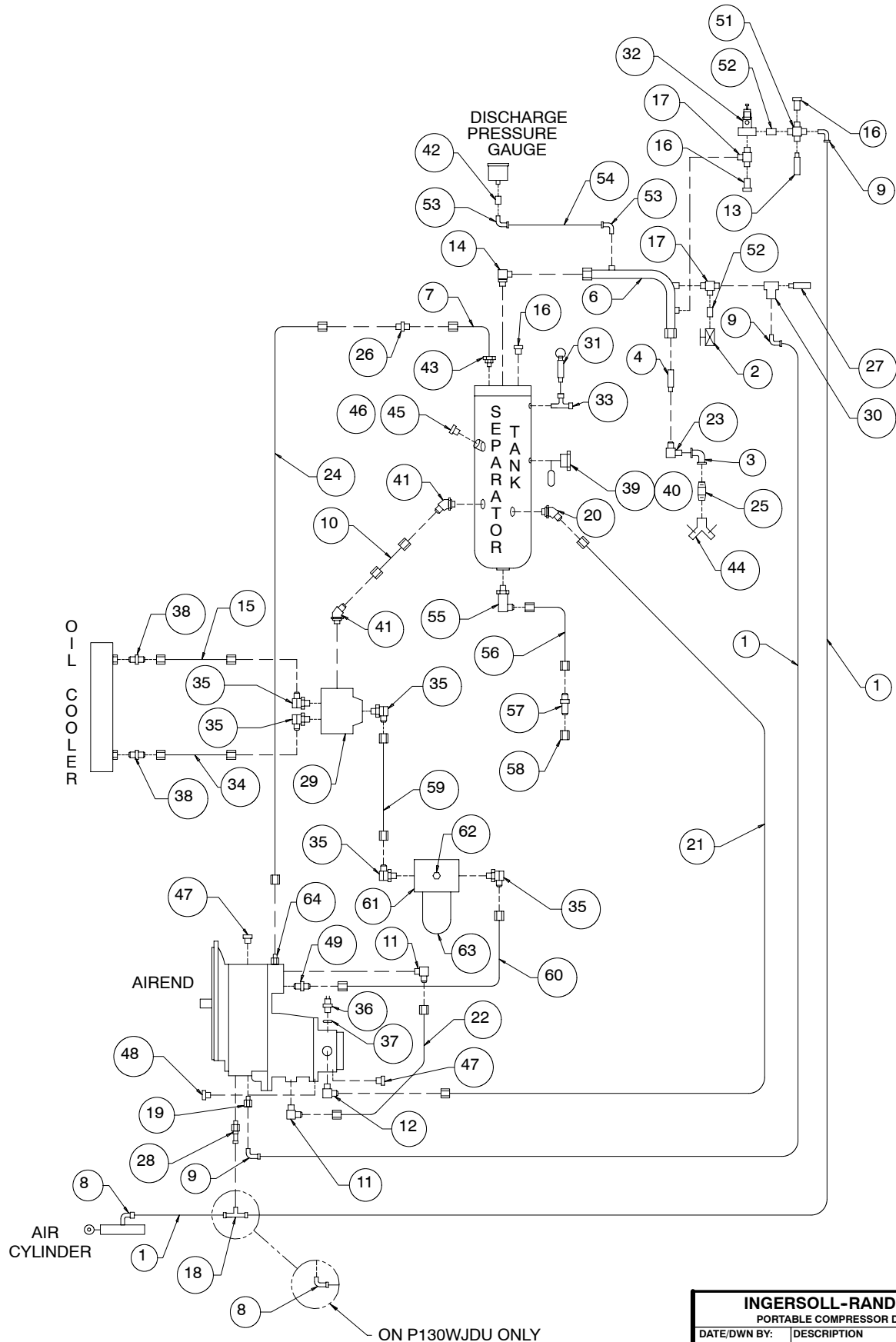

INGERSOLL-RAND COMPANY		
PORTABLE COMPRESSOR DIVISION		
DATE/DWN BY:	DESCRIPTION	
7/07/97	AIR & OIL PIPING	
MODEL NO.	MANUAL NO.	DATE/REV:
P-130AWJDU - P-185AWJDU	35393065-28	4/98 B

ITEM	C.P.N.	DESCRIPTION	ITEM	C.P.N.	DESCRIPTION
1	35356484	TUBING .38 OD	40	36891489	POINTER ASSY
2	35324839	VALVE, BALL .25 NPT	41	35294727	ELB 45° 1.06-12 X -12 JIC
3	95953378	ELB 90° 1.25 NPT	42	95930319	COUPLING .12 NPT
4	35608009	NOZ ,SONIC ORF (P130WJD) {PRIOR TO S/N 305271}	43	36890317	SLEEVE FITTING
	36923910	NOZ ,SONIC ORF (P130WJD) {BEGIN WITH S/N 305271}	44	36881076	VALVE, SERVICE
	35608025	NOZ ,SONIC ORF (P175WJD)	45	35579630	PLUG, VENTED 1.62-12 SAE
	36865129	NOZ ,SONIC ORF (P185WJD) {PRIOR TO S/N 305271}	46	35279942	O-RING
	36921377	NOZ ,SONIC ORF (P185WJD) {BEGIN WITH S/N 305271}	47	35287556	PLUG .56-18 SAE
5			48	35289057	PLUG .44-20 SAE
6	36891505	TUBE ASSY-SERVICE AIR	49	36885093	ELB 90° LONG -12 JIC (P185)
7	36781227	TUBE ASSY - OIL SCAVENGE		35295880	CONN -12 JIC (P130 & P175)
8	35370386	ELB 90° .12 NPT X .38TBG	50		
9	35369354	ELB 90° .25 NPT X .38TBG	51	95954293	CROSS, .25 NPT
10	35287721	HOSE ASSY -12 JIC	52	95667341	NIPPLE, .25 NPT X .88 LNG
11	35286491	ELB 90° .875-14 X -10 JIC	53	36891547	ELB 90° .12 NPT X .12 TBG
12	35374867	ELB 90° 1.875-12 X -20 JIC	54	36891562	TUBING .12 OD
13	36766756	ORIFICE .140	55	36891059	ELB 90° .75-16 X -8 JIC
14	35279777	ELB 90° 1.62-12 X -20 JIC	56	35283043	HOSE ASSY -8
15	36891091	TUBE ASSY -12 JIC	57	35285451	BULKHEAD UNION -8 JIC
16	95928230	PLUG, .25 NPT	58	35313428	CAP -8 JIC
17	35114545	TEE, STREET .25 NPT	59	35289503	HOSE ASSY -12 JIC
18	35369396	TEE MALE BRANCH .12NPT X .38TBG	60	35323864	HOSE ASSY -12 JIC (P185)
19	35302314	ADAPTER .56-18 X .25 NPT		35289503	HOSE ASSY -12 JIC (P130 & P175)
20	35283191	ELB 45° 1.62-12 X -20 JIC	61	35355460	HEAD, FILTER {PRIOR TO S/N 300624}
21	35121243	HOSE ASSY -20 JIC		36897445	HEAD, FILTER {BEGIN WITH S/N 300624}
22	36764553	TUBE ASSY -10 JIC	62	35287556	PLUG .56-18 SAE
23	95219861	ELB 90° 1.25 NPT X -20 JIC	63	35296920	ELEMENT OIL FLTR {PRIOR TO S/N 300624}
24	35315407	HOSE ASSY -4 JIC		36897353	ELEMENT OIL FLTR {BEGIN WITH S/N 300624}
25	95916268	NIPPLE 1.25 X 8 LG	64	35612175	CONN .75-16 X -4 JIC
26	36840437	INLINE ORIFICE/CHK VLV	65		
27	36766772	ORIFICE .062	66		
28	36886992	VALVE CHK ORIFICE .078	67		
29	36884179	VALVE BYPASS	68		
** 30	35322379	VALVE BLOWDOWN	69		
*			70		
31	35325166	VALVE, SAFETY 150 PSI	71		
** 32	36854149	REG. PRESS 100 PSI	72		
33	95944708	TEE STREET .50 NPT	73		
34	36891133	TUBE ASSY -12 JIC	** 74		
35	35294750	ELB 90° 1.06-12 X -12 JIC	75		
36	35596436	SWITCH SHUTDOWN	76		
37	39404165	O-RING	77		
38	35295880	CONN 1.06-12 X -12 JIC			
39	36891083	OIL LEVEL INDICATOR			

* 35379064 REPAIR KIT BLOWDOWN VALVE

** 35387919 REPAIR KIT DIAPHRAGM

INGERSOLL-RAND COMPANY		
PORTABLE COMPRESSOR DIVISION		
DATE/DWN BY:	DESCRIPTION	
7/07/97	bc AIR & OIL PIPING	
MODEL NO.	MANUAL NO.	DATE/REV:
P-130AWJDU - P-185AWJDU	35393065-29	11/99 D

SEPARATOR ELEMENT
DELTA P INDICATOR
OPTION

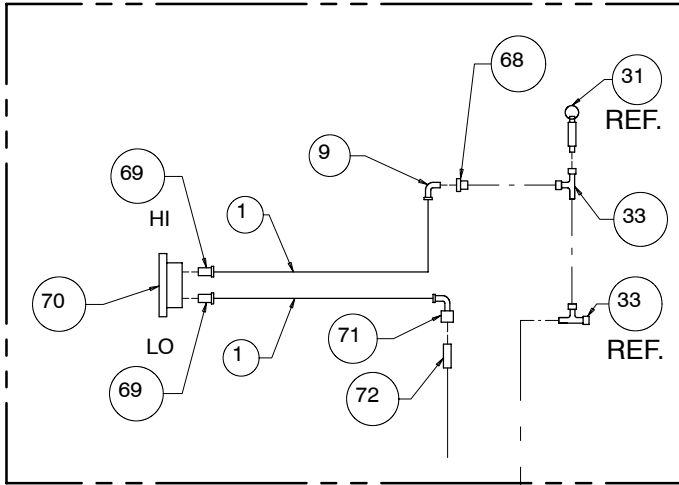

ELECTRIC
START / RUN
VALVE
OPTION

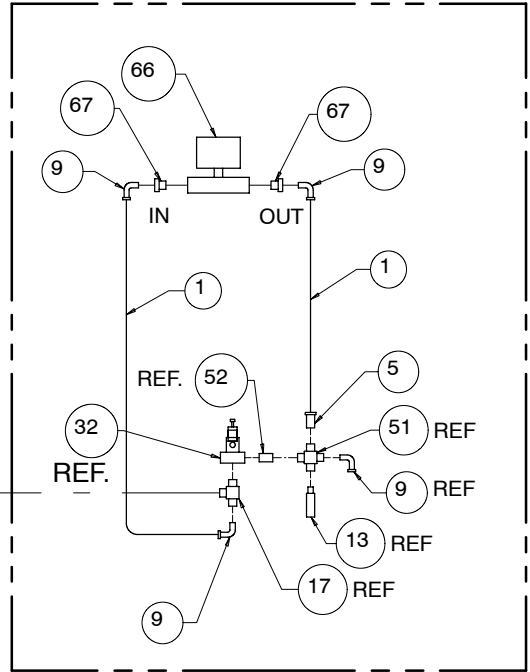

DUAL PRESSURE
REGULATION
OPTION

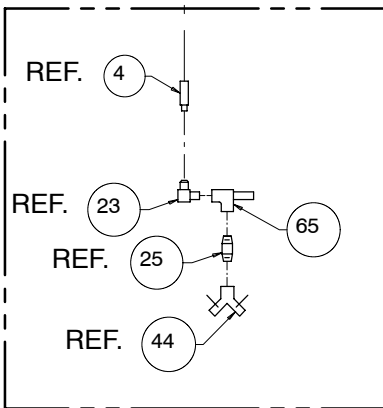
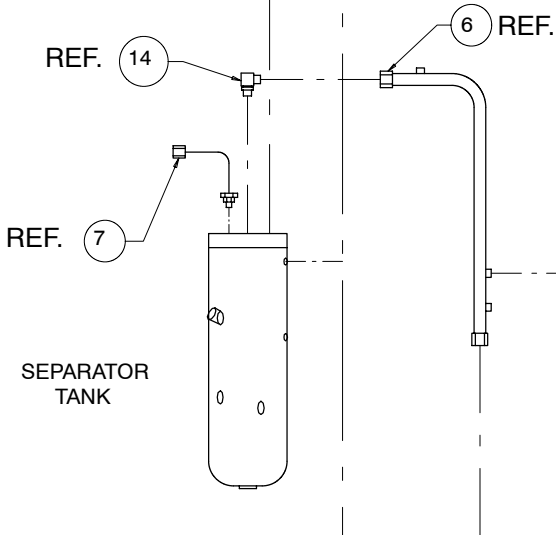
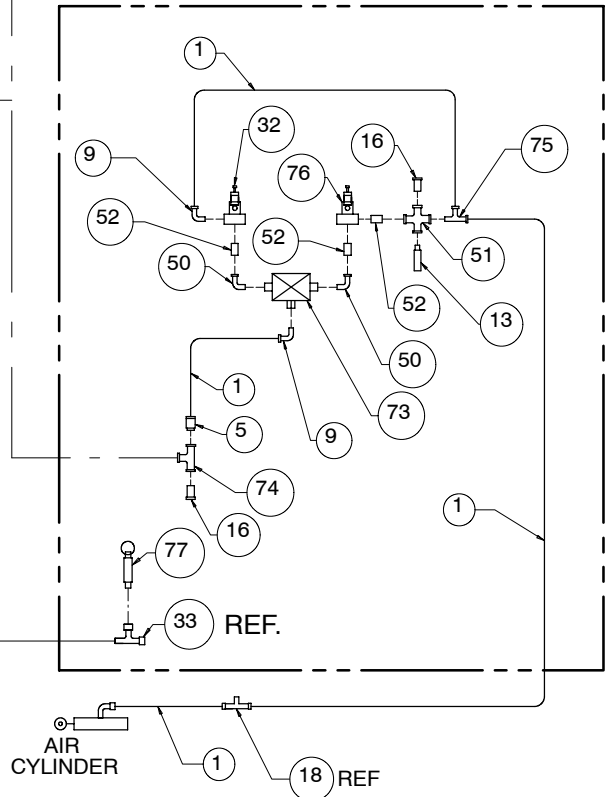

MINIMUM PRESSURE
VALVE OPTION

INGERSOLL-RAND COMPANY		
PORTABLE COMPRESSOR DIVISION		
DATE/DWN BY:	DESCRIPTION	
7/07/97	bc	AIR & OIL PIPING
MODEL NO.	MANUAL NO.	DATE/REV:
P-130AWJDU - P-185AWJDU	35393065-30	4/98 B

ITEM	C.P.N.	DESCRIPTION	ITEM	C.P.N.	DESCRIPTION
1	35356484	TUBING .38 OD	40		
2			41		
3			42		
4	35608009	NOZZLE ,SONIC ORIFICE (P130WJD)	43		
	35608025	NOZZLE ,SONIC ORIFICE (P175WJD)	44	36881076	VALVE, SERVICE
	36865129	NOZZLE ,SONIC ORIFICE (P185WJD)	45		
5	35369347	CONN .25 NPT X .38TBG	46		
6	36891505	TUBE ASSY-SERVICE AIR	47		
7	36781227	TUBE ASSY - OIL SCAVENGE	48		
8			49		
9	35369354	ELB 90° .25 NPT X .38TBG	50	95944666	ELB 90° STREET .25 NPT
10			51	95954293	CROSS, .25 NPT
11			52	95667341	NIPPLE, .25 NPT X .88 LNG
12			53		
13	36766756	ORIFICE .140	54		
14	35279777	ELB 90° 1.62-12 X -20 JIC	55		
15			56		
16	95928230	PLUG, .25 NPT	57		
17	35114545	TEE, STREET .25 NPT	58		
18	35369396	TEE MALE BRANCH .12NPT X .38TBG	59		
19			60		
20			61		
21			62		
22			63		
23	95219861	ELB 90° 1.25 NPT X -20 JIC	64		
24			65	36776219	VALVE, MIN PRESSURE
25	95916268	NIPPLE 1.25 X 8 LG	66	36843142	VALVE, SOLENOID 12VDC
26			67	95940748	BSHG RDC .38 NPT X .25 NPT
27			68	95944625	BSHG RDC .50 NPT X .25 NPT
28			69	35379700	CONN .12 NPT X .38 TBG
29			70	35825546	INDICATOR PRESSURE
* 30			71	35377035	ELB 90° .25 NPT X .38 TBG
31	35325166	VALVE, SAFETY 150 PSI	72	95084059	NIPPLE .25 NPT X 3.0 LNG
** 32	36854149	REG. PRESS 100 PSI	73	36864684	VALVE 3-WAY .25 NPT
33	95944708	TEE STREET .50 NPT	74	35321272	TEE .25 NPT
34			75	35369503	TEE MALE RUN .25 NPT X .38 TBG
35			** 76	36854495	REG. PRESS 150 PSI
36			77	35375971	VALVE SAFETY 188 PSI
37					
38					
39					

* 35379064 REPAIR KIT BLOWDOWN VALVE

** 35387919 REPAIR KIT DIAPHRAGM

INGERSOLL-RAND COMPANY		
PORTABLE COMPRESSOR DIVISION		
DATE/DWN BY:	DESCRIPTION	
7/07/97	AIR & OIL PIPING	
MODEL NO.	MANUAL NO.	DATE/REV:
P-130AWJDU - P-185AWJDU	35393065-31	4/98 B

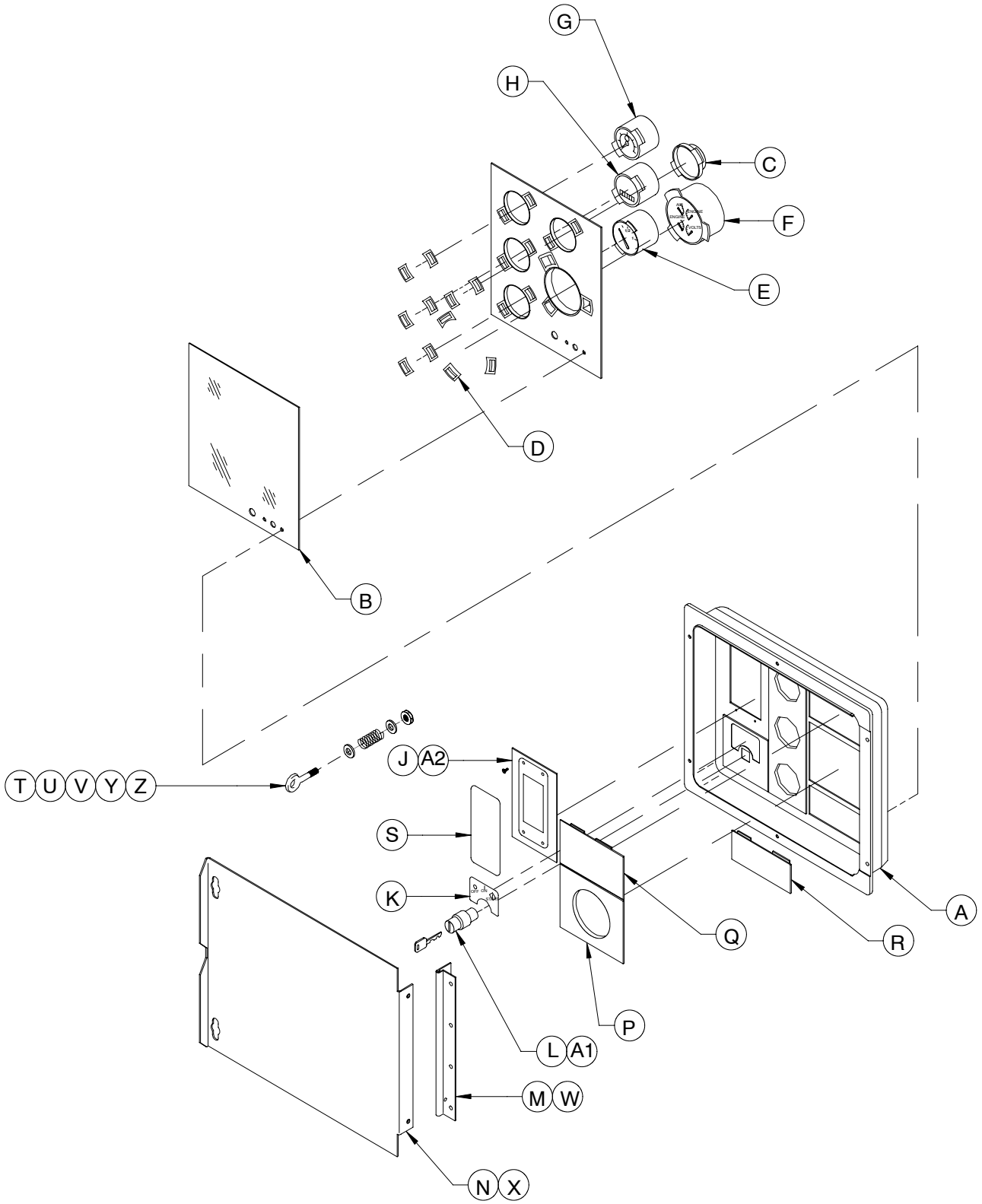

PRIOR TO SERIAL NUMBER 326650

INGERSOLL-RAND COMPANY		
PORTABLE COMPRESSOR DIVISION		
DATE/DWN BY:	DESCRIPTION	
5/12/97	INST/CONT PNL wo/SR VLV	
MODEL NO.	MANUAL NO.	DATE/REV:
P-130AWJDU - P-185AWJDU	35393065-32	4/98 A

ITEM	C.P.N.	QTY	DESCRIPTION
A	36884492	1	RECESSED FRAME ASSEMBLY
B	** 35390368	1	PANEL, ACRYLIC
C	35390319	1	CAP, 2" GAUGE
D	** 36880730	11	CLIP, GAUGE RETAINING
E	36879690	1	GAUGE, FUEL LEVEL
F	36879682	1	GAUGE, 4 in 1
G	36879898	1	GAUGE, 150 PSI PRESSURE
H	36879880	1	HOURMETER
J	35390343	1	COVER, WARNING MODULE
K	36879971	1	DECAL, SWITCH
L	36884211	1	SWITCH, IGNITION
M	36890085	1	HINGE, CONTROL PANEL
N	36891380	1	DOOR, INSTRUMENT PANEL
P	36879716	1	PANEL, 3 3/8 BEZEL
Q	35390285	1	COVER, 2.06" BEZEL
R	35390327	1	PANEL, SWITCH BEZEL
S	36882173	1	LABEL, BLANK WARNING MODULE
T	35607829	2	EYEBOLT
U	95935029	2	WASHER, FLAT
V	36772028	2	WASHER, PLASTIC
W	36920486	6	RIVET
	36920486	6	RIVET, .19 SS
X	36877587	2	RIVET
Y	35607837	2	SPRING
Z	95923298	2	NUT, HEX 1/4-20
A1	36884229	1	KEY
A2	35390400	4	SCREW, #6 X 3/8

{PRIOR TO S/N 296411}
{BEGIN WITH S/N 296411}

** FURNISHED WITH ITEM "A"

ITEMS "A" THROUGH "L" AND "P" THROUGH "S" ARE INCLUDED WITH PANEL ASSEMBLY 36890333

PRIOR TO SERIAL NUMBER 326650

INGERSOLL-RAND COMPANY		
PORTABLE COMPRESSOR DIVISION		
DATE/DWN BY:	DESCRIPTION	
5/12/97	INST/CONT PNL wo/SR VLV	
MODEL NO.	MANUAL NO.	DATE/REV:
P-130AWJDU - P-185AWJDU	35393065-32	12/98 C

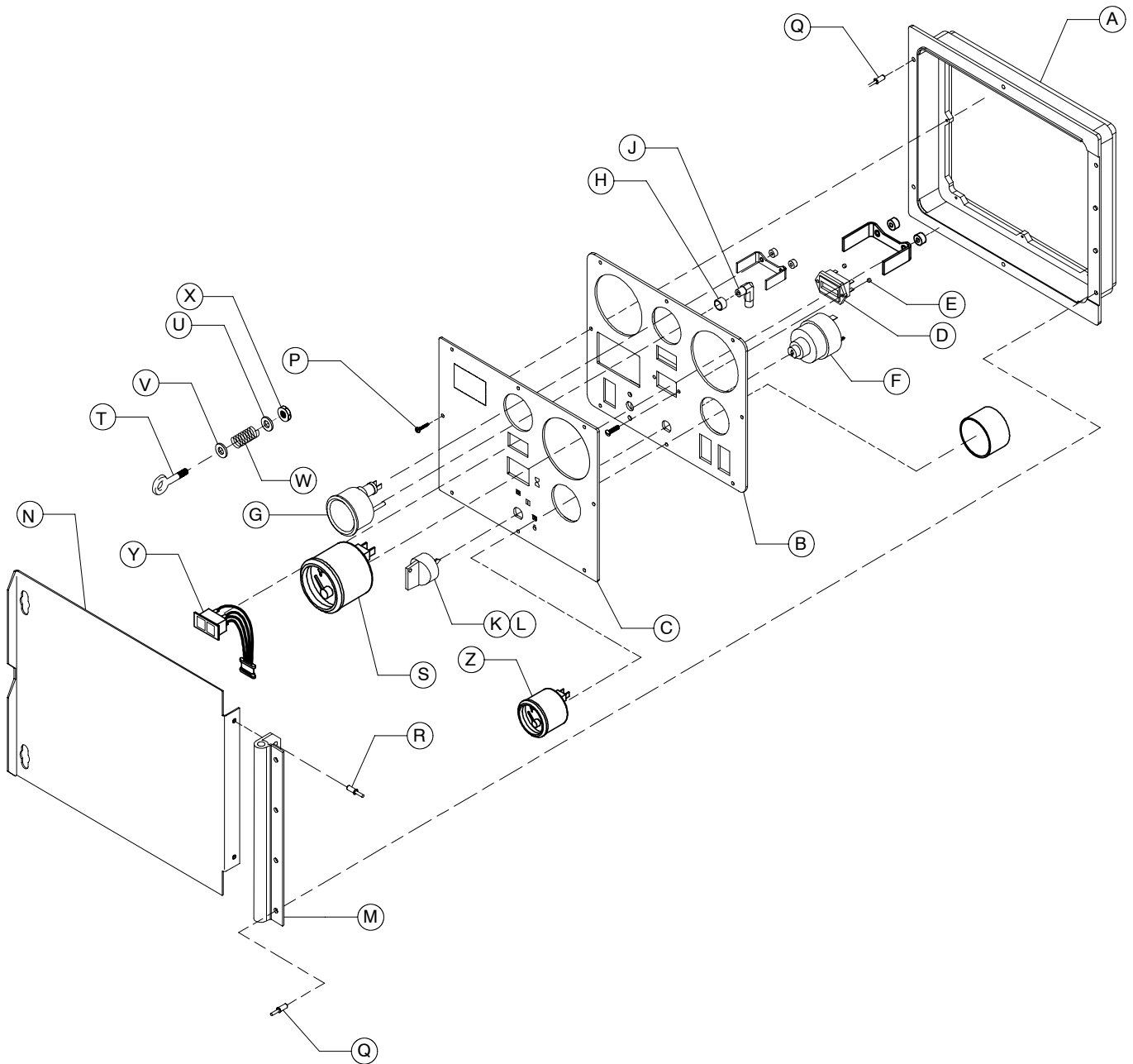

BEGIN WITH SERIAL NUMBER 326650

INGERSOLL-RAND COMPANY		
PORTABLE COMPRESSOR DIVISION		
DATE/DWN BY:	DESCRIPTION	
5/12/97	INST/CONT PNL wo/SR VLV	
MODEL NO.	MANUAL NO.	DATE/REV:
P-130AWJDU - P-185AWJDU	35393065-32	2/02 B

ITEM	C.P.N.	QTY	DESCRIPTION
A	54749601	1	FRAME, WW INSTR PANEL
B	54749619	1	PANEL, INSTRUMENT
C	54766845	1	DECAL, WW INSTR PANEL
D	54766704	1	METER, ELECTRONIC HOUR
E	22054159	2	NUT, PLASTIC 4-40
F	92086719	1	SWITCH, IGNITION
G	35604065	1	GAUGE, 150 PSI PRESSURE
H	95935599	1	COUPLING, STD 1/8 NPT X .75
J	35370386	1	ELBOW, 1/8 NPT X 3/8 TUBE
K	22054167	1	KEY, REMOVABLE IGNITION
L	54774104	1	KEY, NON-REMOVABLE IGNITION
M	36890085	1	HINGE, CONTROL PANEL
N	36897380	1	DOOR, INSTRUMENT PANEL
P	22070494	8	SCREW, PLASTIC TAPPING
Q	36920486	6	RIVET, 3/16 ALUMINUM
R	36877587	4	RIVET, 3/16 ALUMINUM
S	22058291	1	GAUGE ASM., 4-IN-1
T	35607829	2	EYEBOLT
U	95935029	2	WASHER, FLAT
V	36772028	2	WASHER, PLASTIC
W	35607837	2	SPRING
X	95923298	2	NUT, HEX 1/4-20
Y	54774112	1	MODULE, 2-LIGHT WARNING
Z	54774096	1	GAUGE, FUEL

BEGIN WITH SERIAL NUMBER 326650

INGERSOLL-RAND COMPANY		
PORTABLE COMPRESSOR DIVISION		
DATE/DWN BY:	DESCRIPTION	
5/12/97 bc	INST/CONT PNL wo/SR VLV	
MODEL NO.	MANUAL NO.	DATE/REV:
P-130AWJDU - P-185AWJDU	35393065-32	2/02 D

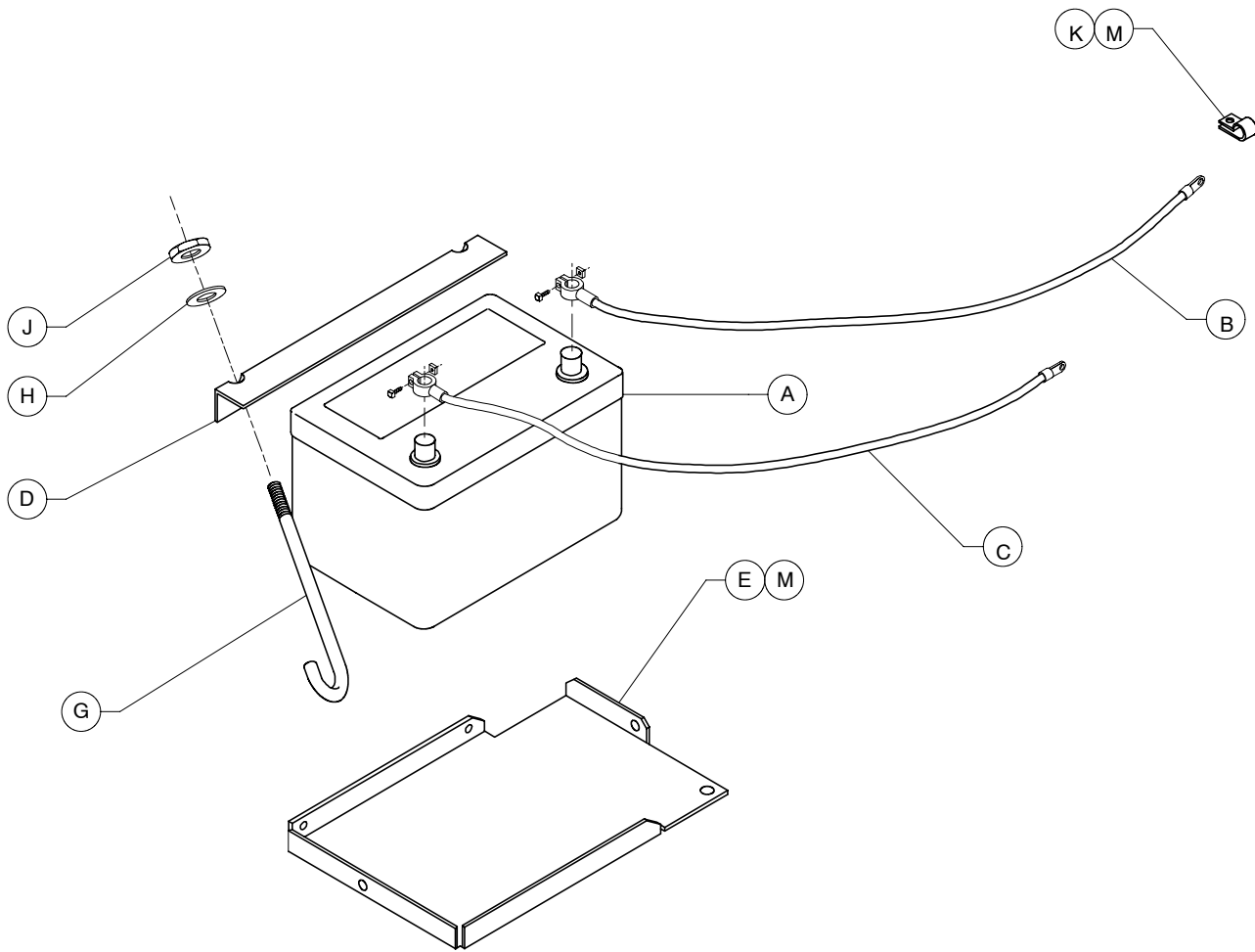
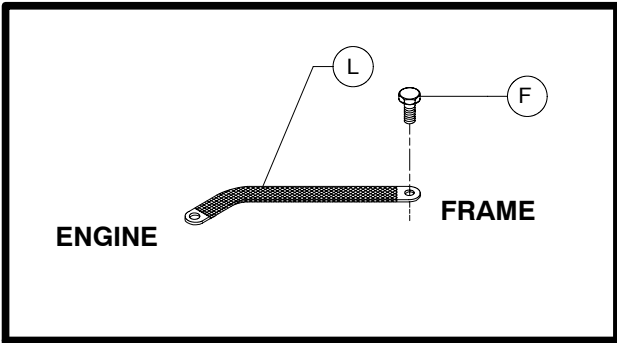

INGERSOLL-RAND COMPANY		
PORTABLE COMPRESSOR DIVISION		
DATE/DWN BY:	DESCRIPTION	
6/16/97	bc	BATTERY & MOUNTING
MODEL NO.	MANUAL NO.	DATE/REV:
P-130WJDU - P-185WJDU	35393065-34	4/98 A

ITEM	C.P.N.	QTY	DESCRIPTION
A	36844264	1	BATTERY
B	35516582	1	CABLE, POSITIVE BATTERY (48")
C	36892685	1	CABLE, NEGATIVE BATTERY (37")
D	36853257	1	ANGLE
E	36890648	1	TRAY, BATTERY
F	35130293	1	SCREW, TAPPING 3/8-16 X 3/4
G	36853240	2	J-BOLT
H	36853265	2	WASHER, PLASTIC
J	35144492	2	NUT, LOCK 1/4-20
K	35225093	2	CLAMP, 1/2" SUPPORT
L	36783488	1	STRAP, GROUND
M	35279025	5	SCREW, TAPPING M08-1.25 X 20

INGERSOLL-RAND COMPANY		
PORTABLE COMPRESSOR DIVISION		
DATE/DWN BY:	DESCRIPTION	
6/16/97 bc	BATTERY & MOUNTING	
MODEL NO.	MANUAL NO.	DATE/REV:
P-130WJDU - P-185WJDU	35393065-35	4/98 A

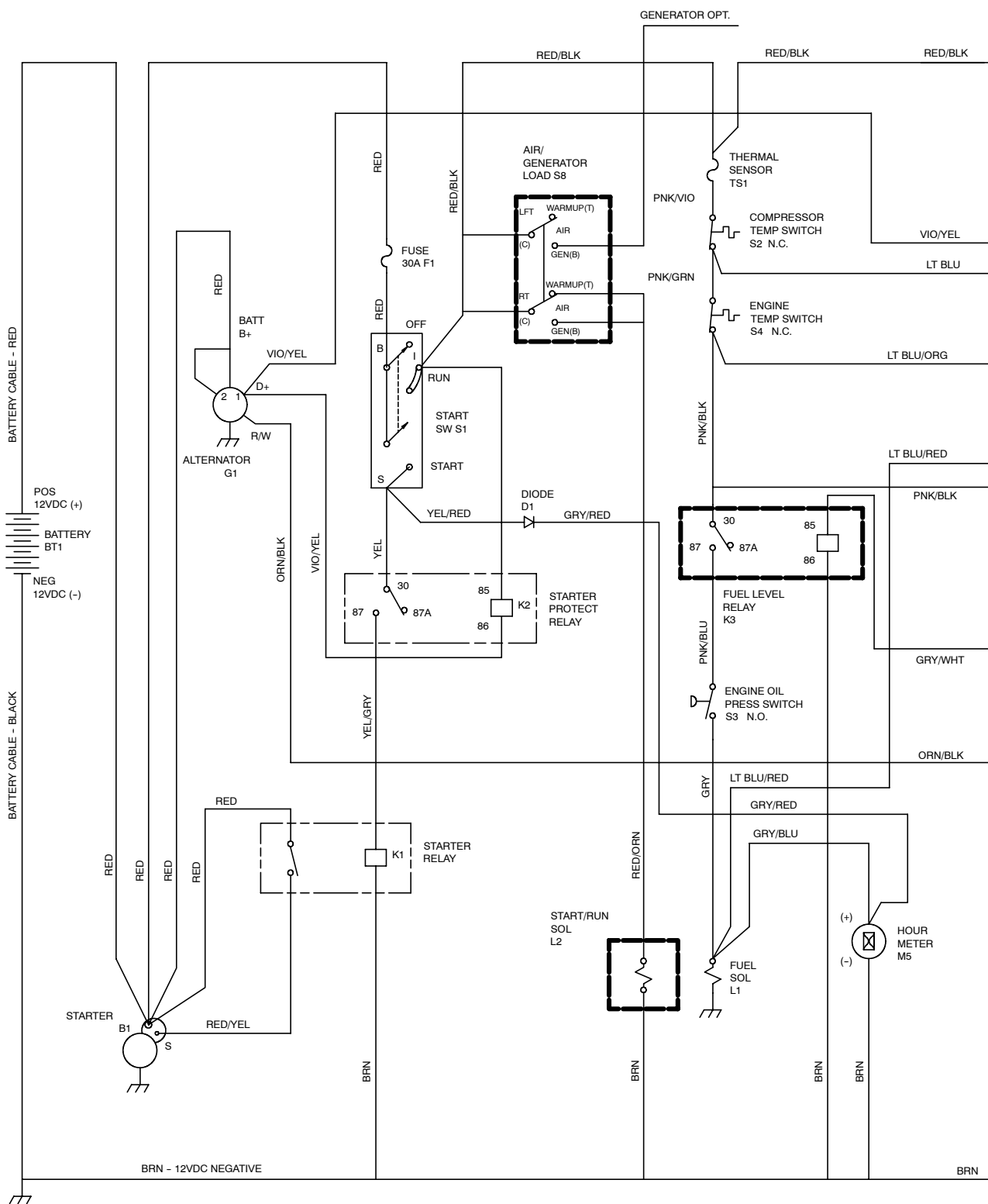

----- OPTIONAL ITEMS

SEE SHT. 3

PRIOR TO SERIAL NUMBER 326650

INGERSOLL-RAND COMPANY		
PORTABLE COMPRESSOR DIVISION		
DATE/DWN BY:	DESCRIPTION	
6/19/97	bc WIRING DIAGRAM	
MODEL NO.	MANUAL NO.	DATE/REV:
P-130WJDU P-185WJDU	35393065-36	4/98 A

ITEM	C.P.N.	DESCRIPTION
B1	*	STARTER
BT1	36844264	BATTERY
D1	35376169	DIODE
F1	36876259	FUSE, 30A
G1	*	ALTERNATOR
K1	36856250	RELAY,STARTER
K2	36878361	RELAY, START PROTECT
K3	36878361	RELAY, FUEL LEVEL
L1	*	SOLENOID, FUEL
L2	36843142	SOLENOID, START/RUN
M5	36879880	HOURMETER
S1	36884211	SWITCH, START
S2	35596436	SWITCH, CPRSR TEMP
S3	36878379	SWITCH, ENGINE OIL
S4	36893055	SWITCH, ENGINE TEMP
S8	36892545	SWITCH, AIR/GENERATOR LOAD
TS1	36865756	SENSOR, THERMAL
W1	36891406	HARNESS, ENGINE

* FURNISHED BY ENGINE MANUFACTURER

PRIOR TO SERIAL NUMBER 326650

INGERSOLL-RAND COMPANY		
PORTABLE COMPRESSOR DIVISION		
DATE/DWN BY:	DESCRIPTION	
6/19/97	bd	WIRING DIAGRAM
MODEL NO.	MANUAL NO.	DATE/REV:
P-130WJDU - P-185WJDU	35393065-37	10/01 B

S1 KEYSWITCH OPERATION SEQUENCE

ITEM	B	U	N	G	S	LG	O	K	P	R	W	Y
COLOR	BLK	BLU	BRN	GRN	GRY	LT GRN	ORG	PNK	PUR	RED	WHT	YEL

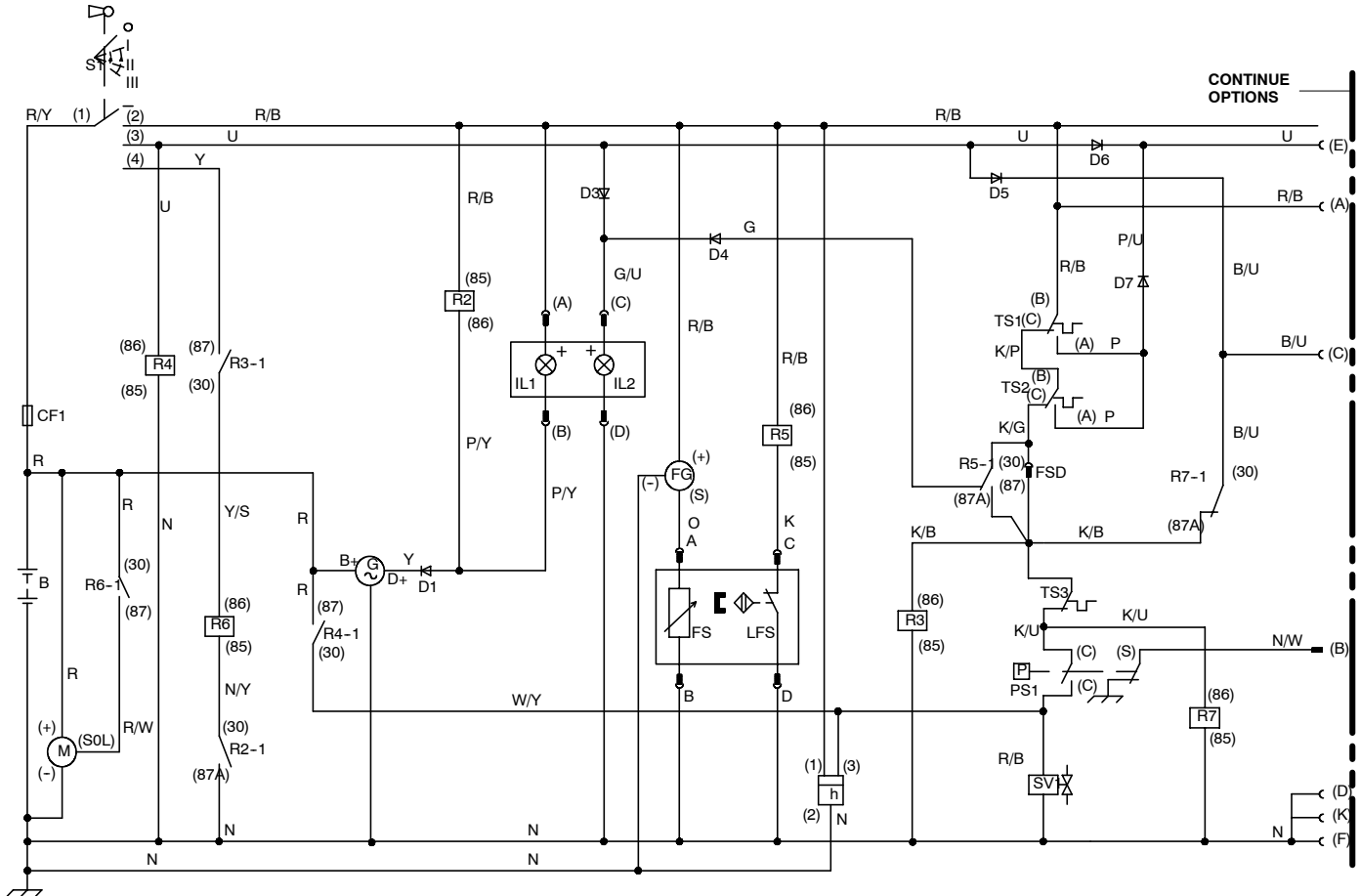
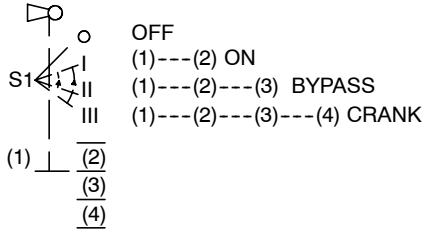

BEGIN WITH SERIAL NUMBER 326650

INGERSOLL-RAND COMPANY		
PORTABLE COMPRESSOR DIVISION		
DATE/DWN BY:	DESCRIPTION	
6/19/97 bc	WIRING DIAGRAM	
MODEL NO.	MANUAL NO.	DATE/REV:
P-130WJDU - P-185WJDU	35393065-36	2/02 B

ITEM C.P.N. QTY. DESCRIPTION

B	36844264	1	BATTERY
CF1	36792083	1	FUSE, 20A
D1	35676169	1	DIODE
D3	35676169	1	DIODE
D4	35676169	1	DIODE
D5	35676169	1	DIODE
D6	35676169	1	DIODE
D7	35676169	1	DIODE
G	36115558	1	ALTERNATOR (3CYLINDER)
	36124881	1	ALTERNATOR (4 CYLINDER)
FG	54774096	1	GAUGE, FUEL
FS	22058531	1	SENDER, FUEL
H	54766704	1	HOURMETER
** IL1	54774112	1	LOW OIL PRESS INDICATOR LAMP
** IL2	54774112	1	LOW OIL PRESS INDICATOR LAMP
* LFS	22058531	1	SWITCH, LOW FUEL
M	36120269	1	STARTER (3 CYLINDER)
	36120649	1	STARTER (4 CYLINDER)
PS1	54747935	1	SWITCH, ENGINE OIL PRESSURE
R2	54368048	1	RELAY, START PROTECT
R3	54368048	1	RELAY, START INHIBIT
R4	54368048	1	RELAY, FUEL SOLENOID
R5	54368048	1	RELAY, FUEL SHUTDOWN
R6	54368048	1	RELAY, CRANK
R7	54368048	1	RELAY, HIGH ENG TEMP
S1	92086719	1	SWITCH, KEY
*** SV1	36125409	1	SOLENOID, FUEL (4 CYLINDER)
TS1	54764964	1	SWITCH, A/E HIGH AIR TEMP
TS2	54764956	1	SWITCH, DISCRG HIGH AIR TEMP
TS3	36880706	1	SWITCH, HIGH ENGINE TEMP
W1	22060271	1	HARNES, ENGINE CONTROL
	22054167		KEY, REMOVABLE
	54774104		KEY, NON-REMOVABLE

* FS & LFS COMBINED IN ONE MODULE

** IL1 & IL2 COMBINED IN 2 LAMP MODULE

*** 3 CYLINDER FUEL SOLENOID IS AN INTERGRAL PART OF INJECTION PUMP.

BEGIN WITH SERIAL NUMBER 326650

INGERSOLL-RAND COMPANY		
PORTABLE COMPRESSOR DIVISION		
DATE/DWN BY:	DESCRIPTION	
6/19/97	bd	WIRING DIAGRAM
MODEL NO.	MANUAL NO.	DATE/REV:
P-130WJDU - P-185WJDU	35393065-37	2/02 C

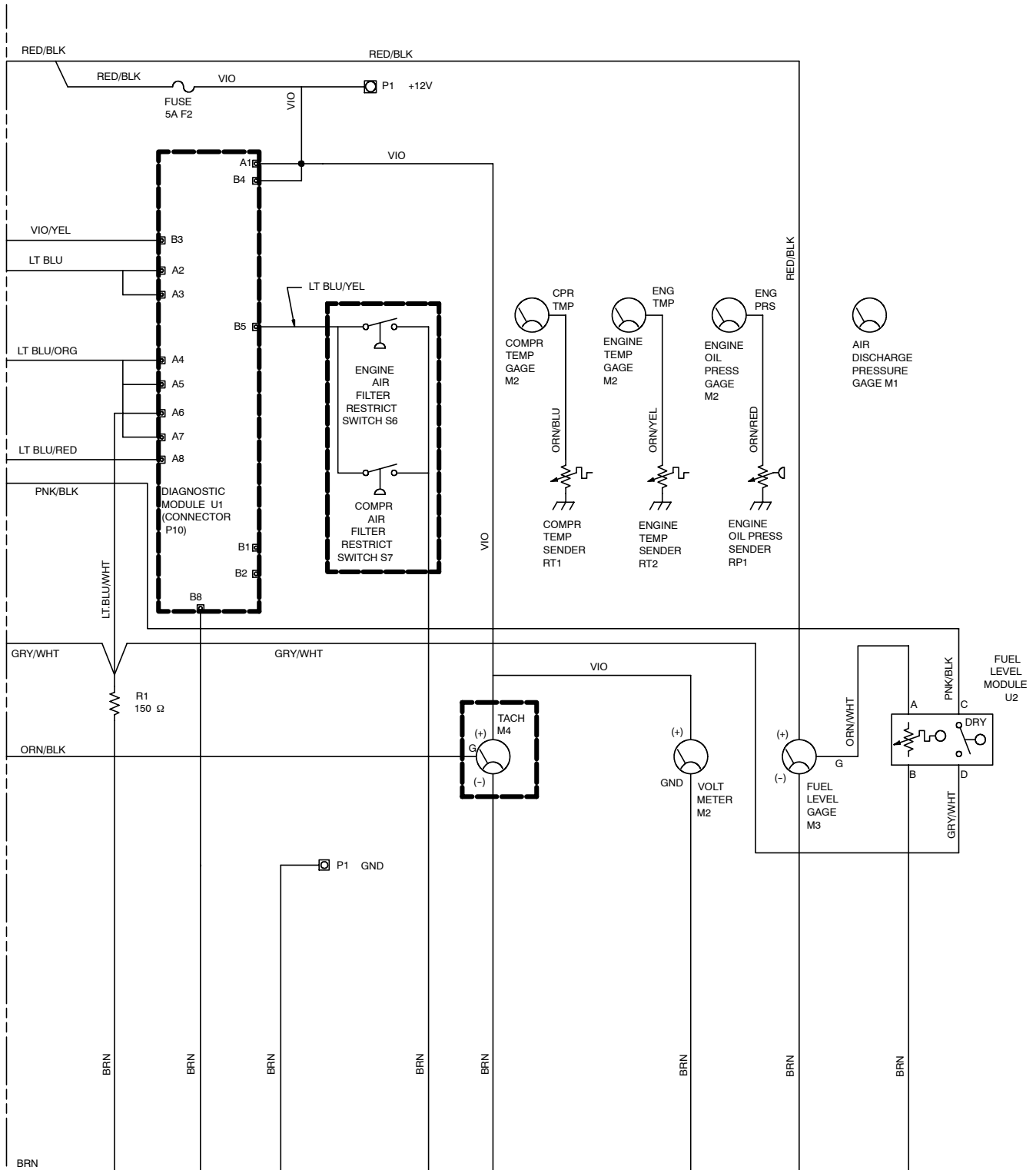

SEE SHT. 1

OPTIONAL ITEMS PRIOR TO SERIAL NUMBER 326650

INGERSOLL-RAND COMPANY		
PORTABLE COMPRESSOR DIVISION		
DATE/DWN BY:	DESCRIPTION	
6/19/97	bc WIRING DIAGRAM	
MODEL NO.	MANUAL NO.	DATE/REV:
P-130WJDU - P-185WJDU	35393065-38	4/98 A

ITEM	C.P.N.	DESCRIPTION
F2	36782654	FUSE, 5A
M1	36879898	GAGE, DISCHARGE PRESSURE
M2	36879682	GAGE, 4 IN 1
M3	36879690	GAGE, FUEL LEVEL
M4	36879740	TACHOMETER
R1	36892222	RESISTOR
RP1	36870608	SENDER, ENG OIL PRESSURE
RT1	35372457	SENDER, CPRSR TEMP
RT2	35604180	SENDER, ENG TEMP (P130, P175)
	35372457	SENDER, ENG TEMP (P185)
S6	35314939	SWITCH, ENG AIR RSTR IND
S7	35314939	SWITCH, A/E AIR RESTR IND
U1	36882033	MODULE, DIAGNOSTIC
U2	36890200	MODULE, FUEL LEVEL
W1	36891406	HARNES, ENGINE

* FURNISHED BY ENGINE MANUFACTURER

PRIOR TO SERIAL NUMBER 326650

INGERSOLL-RAND COMPANY		
PORTABLE COMPRESSOR DIVISION		
DATE/DWN BY:	DESCRIPTION	
6/19/97	bc	WIRING DIAGRAM
MODEL NO.	MANUAL NO.	DATE/REV:
P-130WJDU - P-185WJDU	35393065-39	4/98 A

ITEM	B	U	N	G	S	LG	O	K	P	R	W	Y	
COLOR	BLK	BLU	BRN	GRN	GRY	LT	GRN	OR	PNK	PUR	RED	WHT	YEL

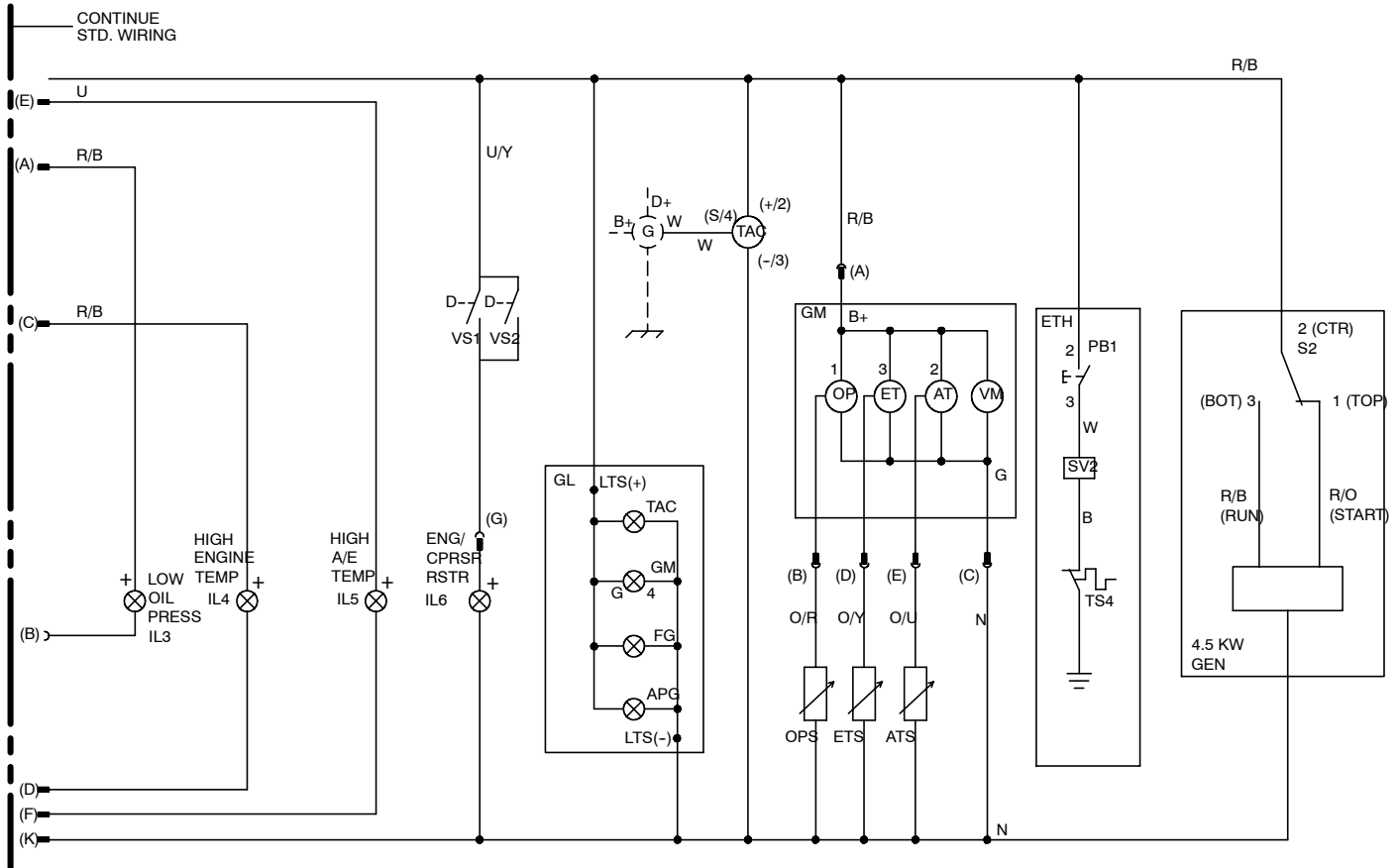

BEGIN WITH SERIAL NUMBER 326650

INGERSOLL-RAND COMPANY		
PORTABLE COMPRESSOR DIVISION		
DATE/DWN BY:	DESCRIPTION	
6/19/97	bc WIRING DIAGRAM	
MODEL NO.	MANUAL NO.	DATE/REV:
P-130WJDU - P-185WJDU	35393065-38	2/02 B

ITEM	C.P.N.	DESCRIPTION
ATS	35372457	AIREND TEMP SENDER
ETH	35367739	MANUAL ETHER START
	35377266	AUTOMATIC ETHER START
ETS	35604180	3 CYL. ENG. TEMP. SENDER
	35372457	4 CYL. ENG. TEMP. SENDER
GEN	36852622	4.5 KW GENERATOR
GL	36852622	GAUGE LIGHTS
	35333236	BULB, INCANDESCENT
IL3	** 22061493	LOW OIL PRESS INDICATOR LAMP
IL4	** 22061493	HIGH ENG TEMP INDICATOR LAMP
IL5	** 22061493	HIGH A/E TEMP INDICATOR LAMP
IL6	** 22061493	HIGH A/E TEMP INDICATOR LAMP
OPS	36870608	OIL PRESSURE SENDER
PB1	*	PUSH BUTTON SWITCH
SV2	*	TACHOMETER
TAC	22060198	SOLENOID, ETHER
TS4	*	SWITCH, BLOCK TEMP. ETHER
VS1	36847838	SWITCH, AIR FILTER RESTRICTION
VS2	36847838	SWITCH, AIR FILTER RESTRICTION
W3	22074843	HARNESS, GAUGE ILLUMINATION OPTION
W4	36842839	HARNESS, AIR FILTER RESTR OPTION
W5	36842821	HARNESS, MANUAL COLD START OPTION

* INCLUDED IN OPTION

** IL3 THROUGH IL6 COMBINED IN 4 LAMP MODULE

BEGIN WITH SERIAL NUMBER 326650

INGERSOLL-RAND COMPANY		
PORTABLE COMPRESSOR DIVISION		
DATE/DWN BY:	DESCRIPTION	
6/19/97	bd	WIRING DIAGRAM
MODEL NO.	MANUAL NO.	DATE/REV:
P-130WJDU - P-185WJDU	35393065-39	2/02 B

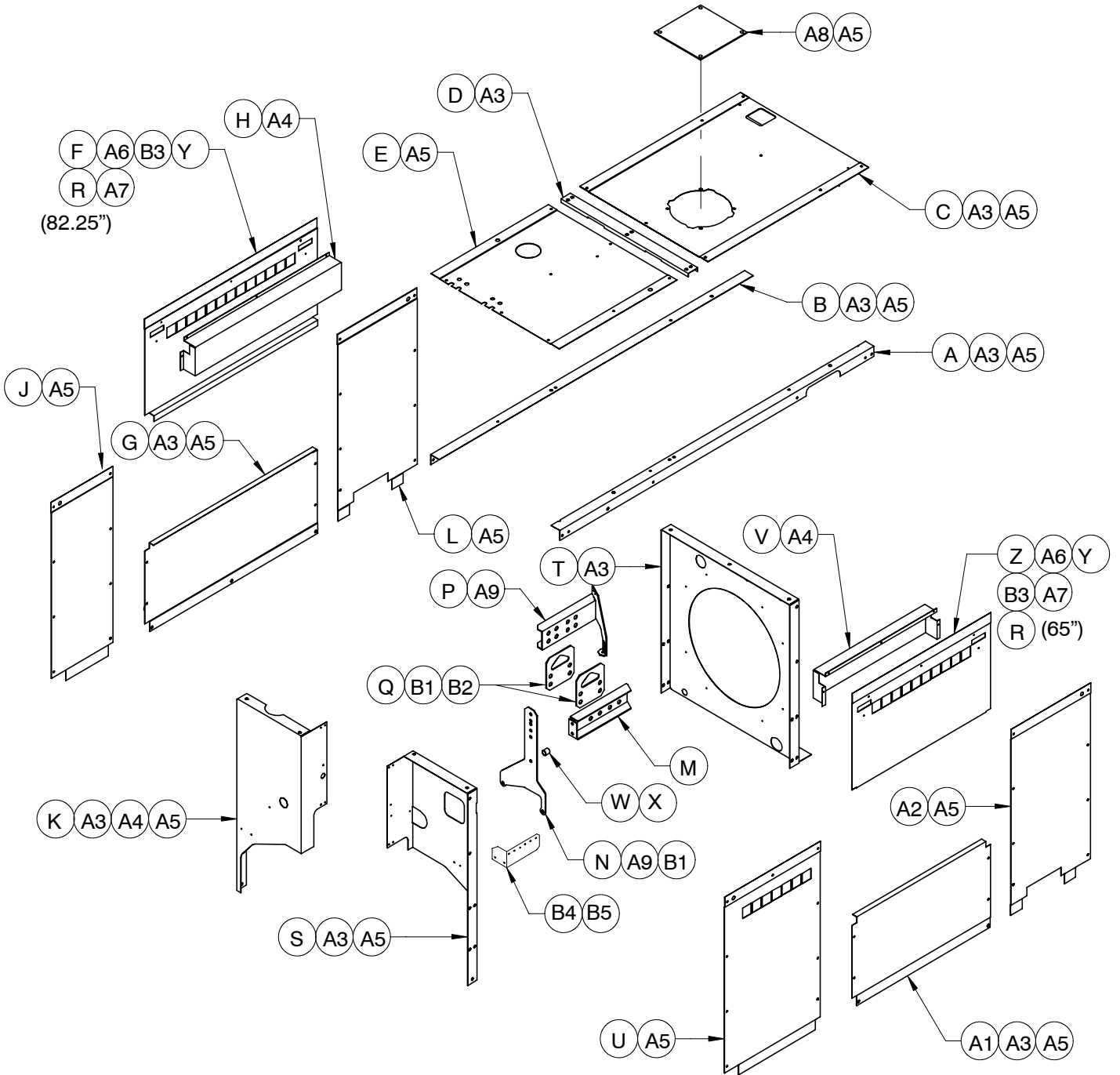

INGERSOLL-RAND COMPANY		
PORTABLE COMPRESSOR DIVISION		
DATE/DWN BY:	DESCRIPTION	
6/13/97	bd	ENCLOSURE COMPLETE
MODEL NO.	MANUAL NO.	DATE/REV:
P-130AWJDU - P-185AWJDU	35393065-40	2/02 B

ITEM	C.P.N.	QTY	DESCRIPTION
A	36890531	1	STRINGER, CAB SIDE
B	36890549	1	STRINGER, BED SIDE
C	36890762	1	PANEL, ROOF CLR END
D	36891414	1	CHANNEL, ROOF CONNECTOR
E	36890838	1	PANEL, ROOF (P130, P175)
	36890754	1	PANEL, ROOF (P185)
F	36890739	1	PANEL, UPPER ENG BED
G	36890721	1	PANEL, LWR ENG BED
H	36890812	1	BOX, AIR INLET BED
J	36890747	1	PANEL, FILTER END BED
K	36890804	1	BULKHEAD, REAR BED
L	36890713	1	PANEL, COOLER END BED
M	36891745	1	STRINGER, LIFT BEAM
N	36891729	1	MEMBER, LIFT BEAM REAR
P	36891737	1	MEMBER, LIFT BEAM FRONT
Q	36891760	2	EYE, LIFT BEAM
R	35368216	*	FOAM
S	36890796	1	BULKHEAD, REAR CAB
T	36892040	1	ORIFACE, FAN (P130, P175)
	36890473	1	ORIFACE, FAN (P185)
U	36890705	1	PANEL, FILTER END CAB
V	36890770	1	BOX, AIR INLET CAB
W	36892982	1	SPACER (P130, P175)
X	92304450	1	SCREW, HEX M12-1.75 X 50
Y	36786218	2	LANYARD, 1.6 X 355.6
Z	36890697	1	PANEL, UPPER ENG CAB
A1	36890689	1	PANEL, LWR ENG CAB
A2	36890655	1	PANEL, COOLER END CAB
A3	36895746	51	NUTSERT, HEX M08
A4	36877587	15	RIVET, 3/16 Ø
A5	35279025	73	SCREW, TAPPING M08-125 X 20
A6	36892677	4	LATCH, TRIGGER
A7	36861383	4	HOOK, #9 S
A8	35279413	1	COVER, ROOF ACCESS
A9	36879492	5	SCREW, HEX FLANGE M12 X 25
	36881712	2	SCREW, HEX FLANGE 1/2-13 X 1.0
B1	36879203	7	NUT, HEX FLANGE M12-1.75
B2	36877793	4	SCREW, HEX FLANGE M12-1.75 X 40
B3	36892206	4	CAP, VINYL
B4	22095533	1	BRACKET, RELAY MOUNTING
B5	36797652	2	SCREW, TAPPING M06-1.0 X 12

BEGIN WITH SERIAL NUMBER 326650
BEGIN WITH SERIAL NUMBER 326650

* SEE ILLUSTRATION FOR LENGHT

INGERSOLL-RAND COMPANY		
PORTABLE COMPRESSOR DIVISION		
DATE/DWN BY:	DESCRIPTION	
6/13/97 bc	ENCLOSURE COMPLETE	
MODEL NO.	MANUAL NO.	DATE/REV:
P-130AWJDU - P-185AWJDU	35393065-41	2/02 C

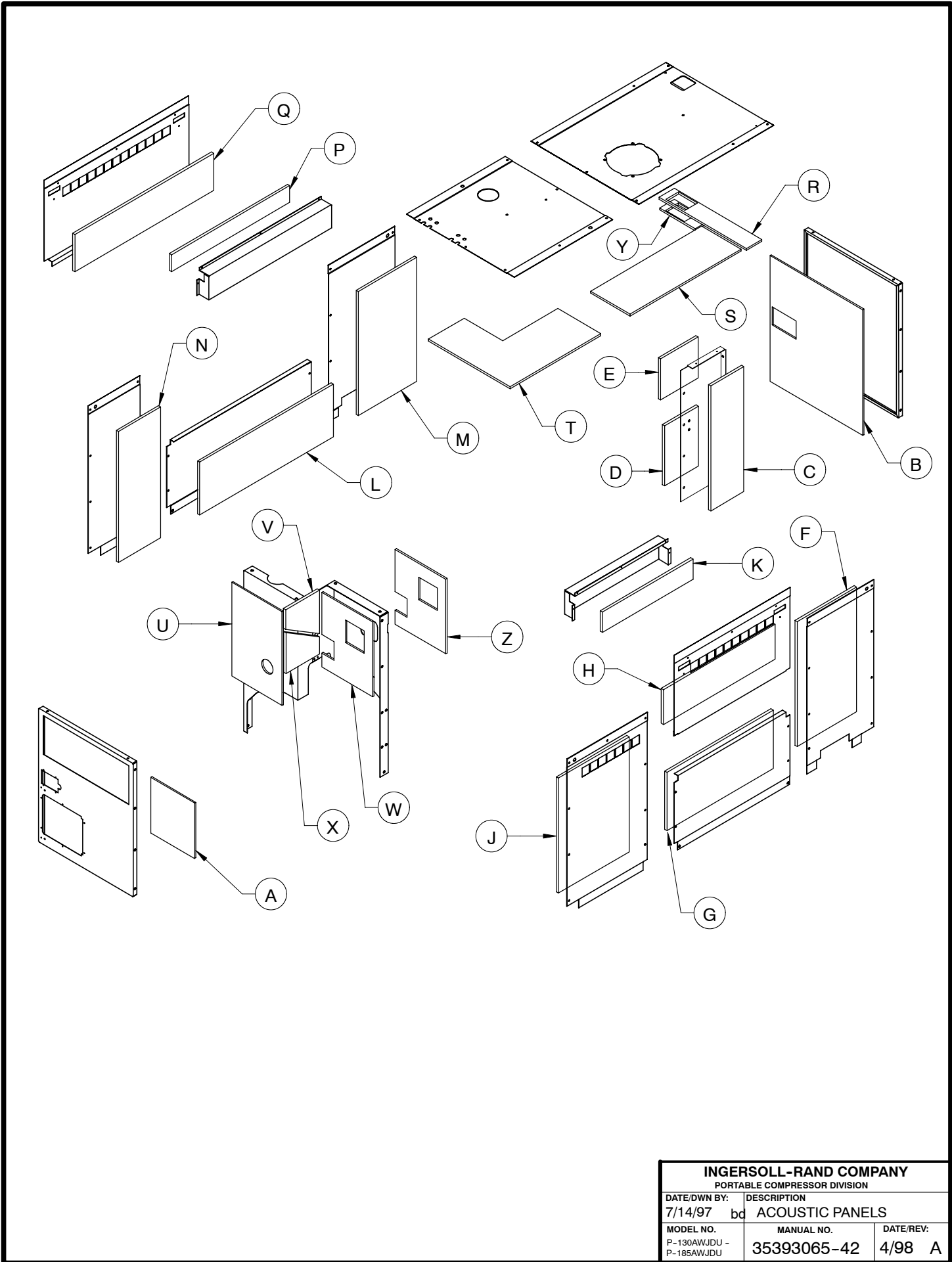

INGERSOLL-RAND COMPANY		
PORTABLE COMPRESSOR DIVISION		
DATE/DWN BY:	DESCRIPTION	
7/14/97	bc ACOUSTIC PANELS	
MODEL NO.	MANUAL NO.	DATE/REV:
P-130AWJDU - P-185AWJDU	35393065-42	4/98 A

ITEM	C.P.N.	QTY	DESCRIPTION
A	36892735	1	PANEL, ACOUSTIC ST DOOR
B	36892792	1	PANEL, ACOUSTIC CRB DOOR
C	36892875	1	PANEL, ACOUSTIC CAB SPLTR
D	36892867	1	PANEL, ACOUSTIC BED SPLTR BOT
E	36892859	1	PANEL, ACOUSTIC BED SPLTR TOP
F	36892743	1	PANEL, ACOUSTIC CAB COOLER
G	36892750	1	PANEL, ACOUSTIC CAB LWR ENG
H	36892768	1	PANEL, ACOUSTIC CAB UPPER ENG
J	36892784	1	PANEL, ACOUSTIC CAB FLTR END
K	36892776	1	PANEL, ACOUSTIC CAB AIR BOX
L	36892818	1	PANEL, ACOUSTIC BED LWR ENG
M	36892842	1	PANEL, ACOUSTIC BED COOLER END
N	36892800	1	PANEL, ACOUSTIC BED FLTR END
P	36892834	1	PANEL, ACOUSTIC BED AIR BOX
Q	36892826	1	PANEL, ACOUSTIC BED UPPER ENG
R	36892883	1	PANEL, ACOUSTIC OIL COOLER TOP
S	36892909	1	PANEL, ACOUSTIC CENTER ROOF
T	36892917	1	PANEL, ACOUSTIC END ROOF
U	36892966	1	PANEL, ACOUSTIC BHD BED SIDE
V	36892941	1	PANEL, ACOUSTIC BHD CTR UPPER
W	36892933	1	PANEL, ACOUSTIC BHD CAB FLTR
X	36892958	1	PANEL, ACOUSTIC BHD CTR LOWER
Y	36892891	1	PANEL, ACOUSTIC
Z	36892925	1	PANEL, ACOUSTIC BHD CAB ENG

INGERSOLL-RAND COMPANY		
PORTABLE COMPRESSOR DIVISION		
DATE/DWN BY:	DESCRIPTION	
7/14/97	ACOUSTIC PANELS	
MODEL NO.	MANUAL NO.	DATE/REV:
P-130AWJDU - P-185AWJDU	35393065-43	4/98 A



WARNING

**Improper operation of this equipment.
Can cause serious injury or death.**
Read Operator's Manual supplied with
this machine before operation or
servicing.

**Modification or alteration of this machine.
Can cause serious injury or death.**
Do not alter or modify this machine
without the express written consent of
the manufacturer.

Ingersoll Rand

54568787 REV. A



WARNING

**Hot pressurized fluid.
Can cause serious burns.**

Do not open radiator while
hot.



Ingersoll Rand

54568781 REV. A

E

D

B

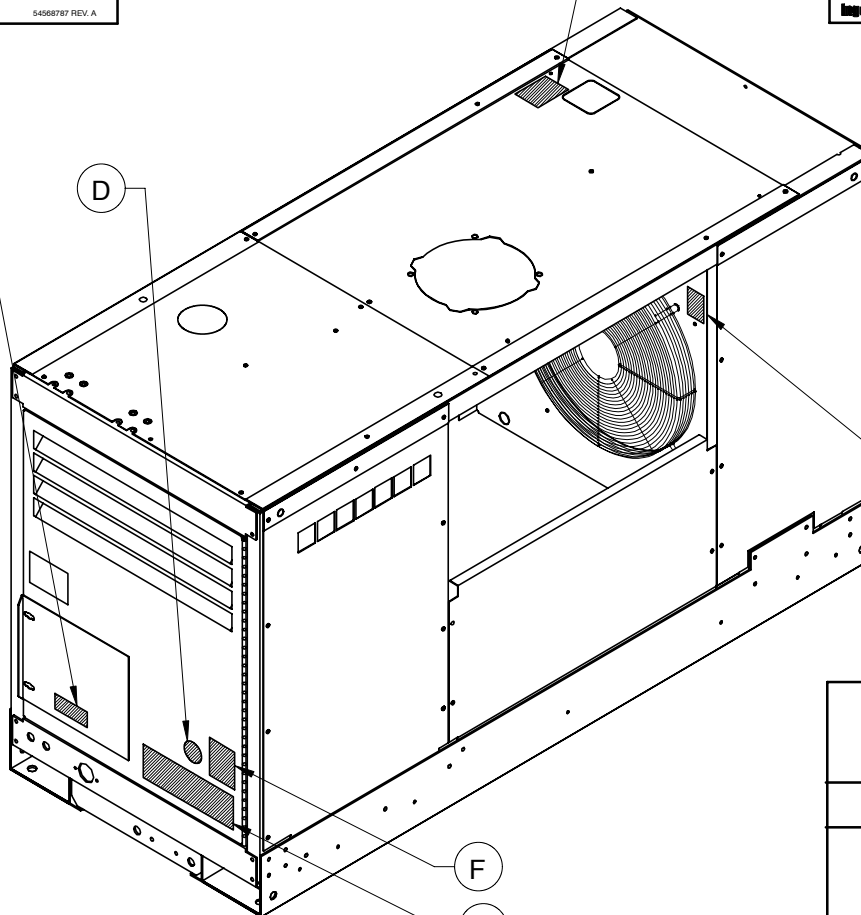

A

F

C



WARNING

**Rotating fan blade.
Can cause serious injury.**

Do not operate without guard
in place.



Ingersoll Rand

54568779 REV. A



DANGER



**Discharged air can contain carbon monoxide
or other contaminants.
Will cause serious injury or death.**

Do not breathe this air.

Ingersoll Rand



WARNING

**Trapped air pressure.
Can cause serious injury or
death.**

Close service valve and
operate tool to vent trapped
air before performing any
service.



WARNING

**Disconnected air hoses whip.
Can cause serious injury
death.**

When using air tools attach safety
device (OSHA Valve) at source of
air supply for each tool.



54629902 REV. A

INGERSOLL-RAND COMPANY PORTABLE COMPRESSOR DIVISION

DATE/DWN BY:	DESCRIPTION	
6/18/97 bc	DECAL LOCATION	
MODEL NO.	MANUAL NO.	DATE/REV:
P-130AWJDU - P-185AWJDU	35393065-44	12/00 B

ITEM	C.P.N.	DESCRIPTION
A	54568779	DECAL, ROTATING FAN
B	54568761	DECAL, HOT PRESS FLUID
C	54629902	DECAL, COMBINATION 3-PART
D	36505816	DECAL, EIT AT WORK
E	54568787	DECAL, IMPROPER OPERATION
F	36514602	DECAL, NOISE EMISSION

INGERSOLL-RAND COMPANY		
PORTABLE COMPRESSOR DIVISION		
DATE/DWN BY:	DESCRIPTION	
6/18/97	bd	DECAL LOCATION
MODEL NO.	MANUAL NO.	DATE/REV:
P-130AWJDU - P-185AWJDU	35393065-45	12/00 B

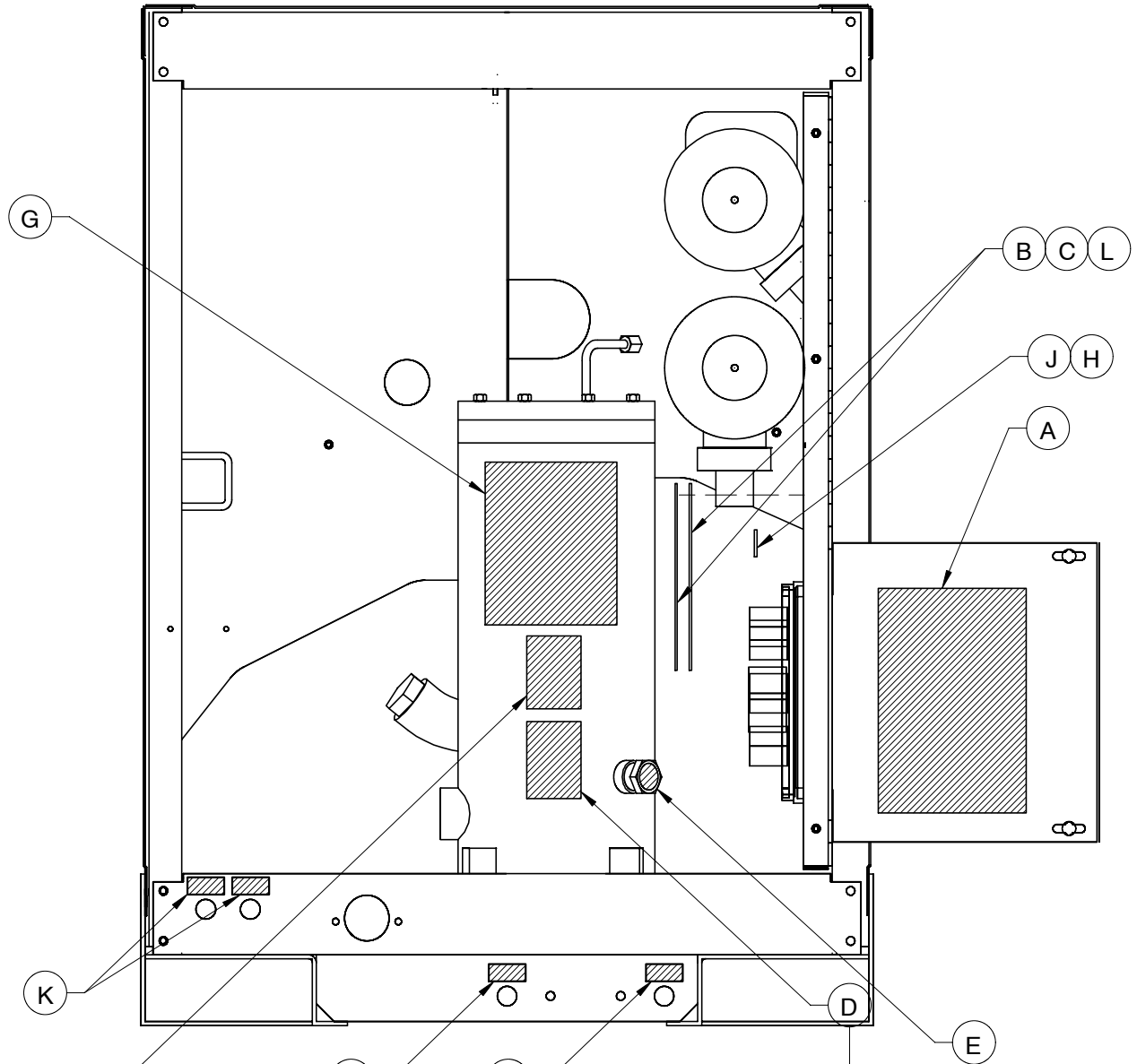



WARNING

High pressure air.
Can cause serious injury
or death.

Relieve pressure before
removing filler plugs/caps,
fittings or covers.



Ingersoll Rand 54568795 REV. A

WARNING

Combustible gas.
Can cause serious burns,
blindness or death.

Keep sparks and open
flames away from batteries.



Ingersoll Rand 54568793 REV. A

PRIOR TO SERIAL NUMBER 326650

INGERSOLL-RAND COMPANY PORTABLE COMPRESSOR DIVISION		
DATE/DWN BY: 6/18/97	DESCRIPTION bd DECAL LOCATION	
MODEL NO. P-130AWJDU - P-185AWJDU	MANUAL NO. 35393065-46	DATE/REV: 12/00 C

ITEM	C.P.N.	DESCRIPTION
A	36879054	DECAL, OPERATING INSTRUCTIONS
B	36531143	CARD, UTILITY SAFETY
C	36847861	TIE, PUSH-MT
D	54568753	DECAL, BATTERY GAS
E	54604970	DECAL, OIL FILL
F	54568795	DECAL, HIGH PRESSURE AIR
G	36531150	DECAL, GENERAL DATA
H	36523306	PLATE, SERIAL NUMBER
J	36794816	RIVET
K	54629977	DECAL, CENTRAL DRAINS
L	36531168	DECAL, WIRING DIAGRAM

PRIOR TO SERIAL NUMBER 326650

INGERSOLL-RAND COMPANY PORTABLE COMPRESSOR DIVISION		
DATE/DWN BY:	DESCRIPTION	
6/18/97	bd	DECAL LOCATION
MODEL NO.	MANUAL NO.	DATE/REV:
P-130AWJDU - P-185AWJDU	35393065-47	12/00 C

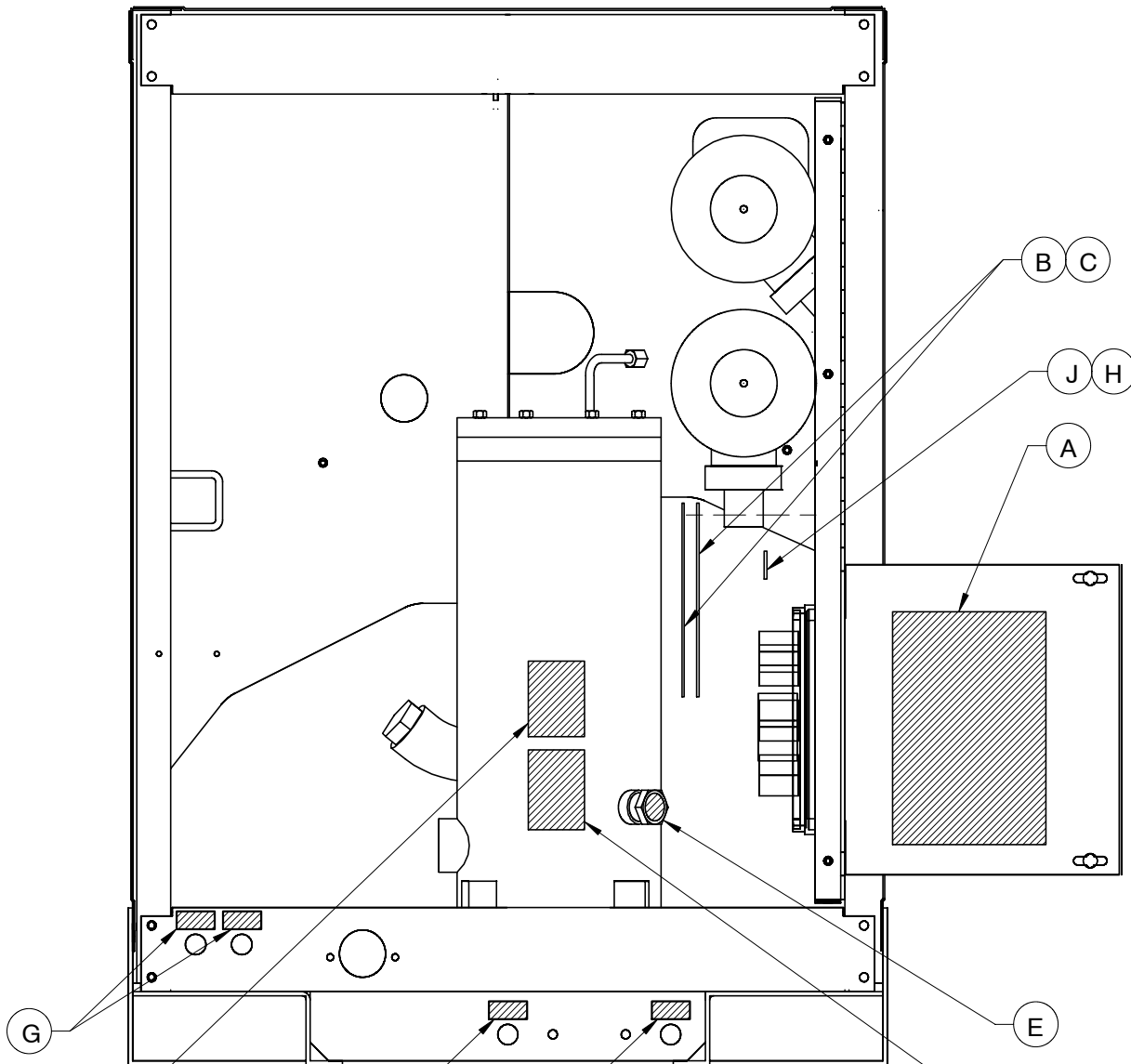

WARNING

High pressure air.
 Can cause serious injury
 or death.

Relieve pressure before
 removing filler plugs/caps,
 fittings or covers.



Ingersoll Rand 54568795 REV. A

BEGIN WITH SERIAL NUMBER 326650

WARNING

Combustible gas.
 Can cause serious burns,
 blindness or death.



Keep sparks and open
 flames away from batteries.

Ingersoll Rand 54568753 REV. A

INGERSOLL-RAND COMPANY		
PORTABLE COMPRESSOR DIVISION		
DATE/DWN BY:	DESCRIPTION	
6/18/97	DECAL LOCATION	
MODEL NO.	MANUAL NO.	DATE/REV:
P-130AWJDU - P-185AWJDU	35393065-46	2/02 D

ITEM	C.P.N.	DESCRIPTION
A	22099311	DECAL, OPERATING INSTRUCTIONS
B	22108617	CARD, STANDARD WIRING
C	22108641	CARD, OPTION WIRING
D	54568753	DECAL, BATTERY GAS
E	54604970	DECAL, OIL FILL
F	54568795	DECAL, HIGH PRESSURE AIR
G	54629977	DECAL, CENTRAL DRAINS
H	36523306	PLATE, SERIAL NUMBER
J	36794816	RIVET

BEGIN WITH SERIAL NUMBER 326650

INGERSOLL-RAND COMPANY		
PORTABLE COMPRESSOR DIVISION		
DATE/DWN BY:	DESCRIPTION	
6/18/97	bd	DECAL LOCATION
MODEL NO.	MANUAL NO.	DATE/REV:
P-130AWJDU - P-185AWJDU	35393065-47	2/02 D

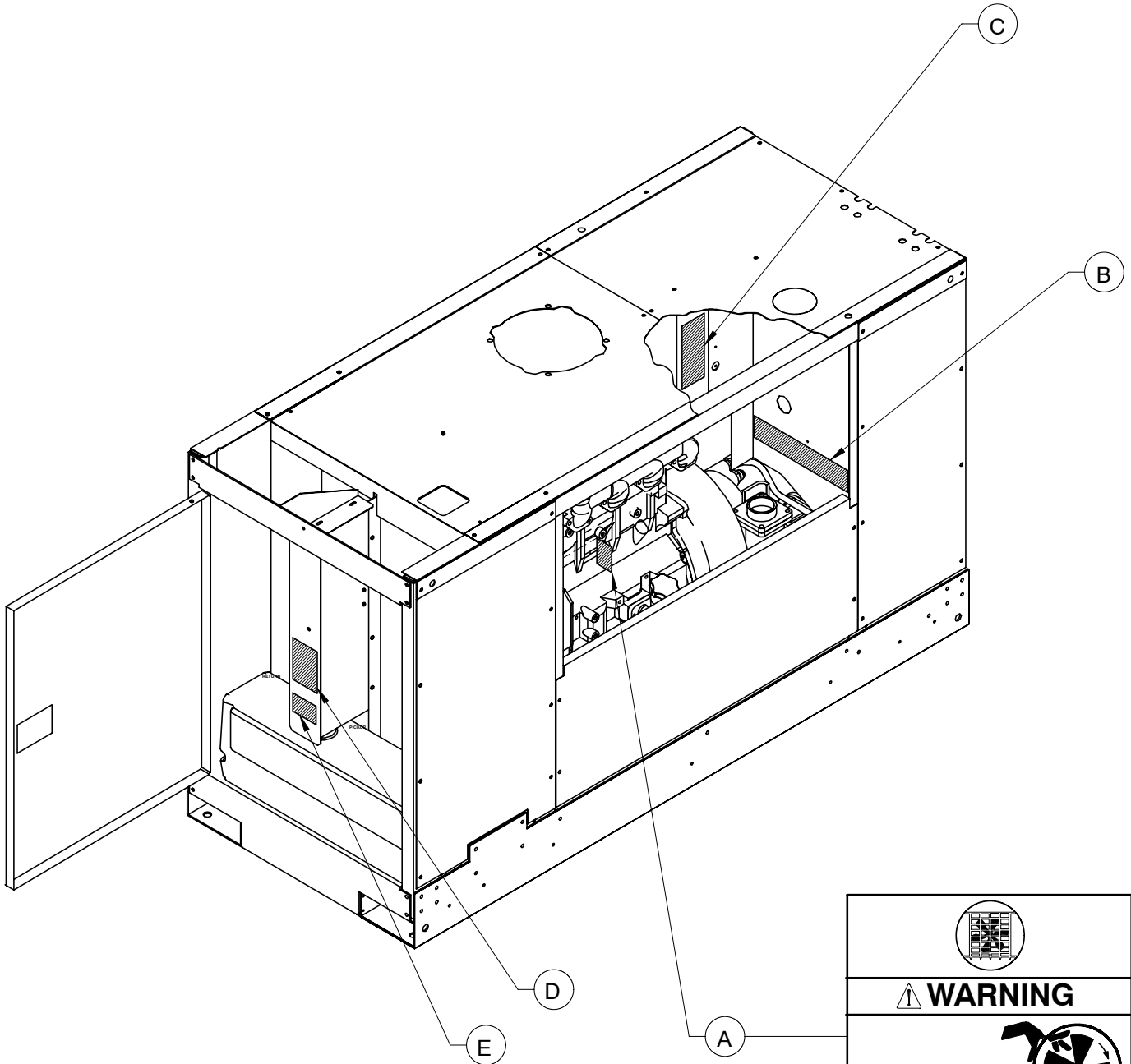



WARNING



**Rotating fan blade.
Can cause serious injury.**

Do not operate without guard
in place.

Ingersoll-Rand 54568779 REV. A

PRIOR TO SERIAL NUMBER 326650

INGERSOLL-RAND COMPANY		
PORTABLE COMPRESSOR DIVISION		
DATE/DWN BY:	DESCRIPTION	
6/18/97	bc	DECAL LOCATION
MODEL NO.	MANUAL NO.	DATE/REV:
P-130AWJDU - P-185AWJDU	35393065-48	12/00 D

ITEM	C.P.N.	DESCRIPTION
A	54568779	DECAL, ROTATING FAN
B	36529394	DECAL, PRESS REG ADJ INST (P130 ONLY)
C	36529451	DECAL, SPD & PRESS REG (P175, P185 ONLY)
D	54604962	DECAL, RAD FILL HOT
E	54625207	DECAL, DIESEL FUEL

PRIOR TO SERIAL NUMBER 326650

INGERSOLL-RAND COMPANY		
PORTABLE COMPRESSOR DIVISION		
DATE/DWN BY:	DESCRIPTION	
6/18/97	bd	DECAL LOCATION
MODEL NO.	MANUAL NO.	DATE/REV:
P-130AWJDU - P-185AWJDU	35393065-49	12/00 D

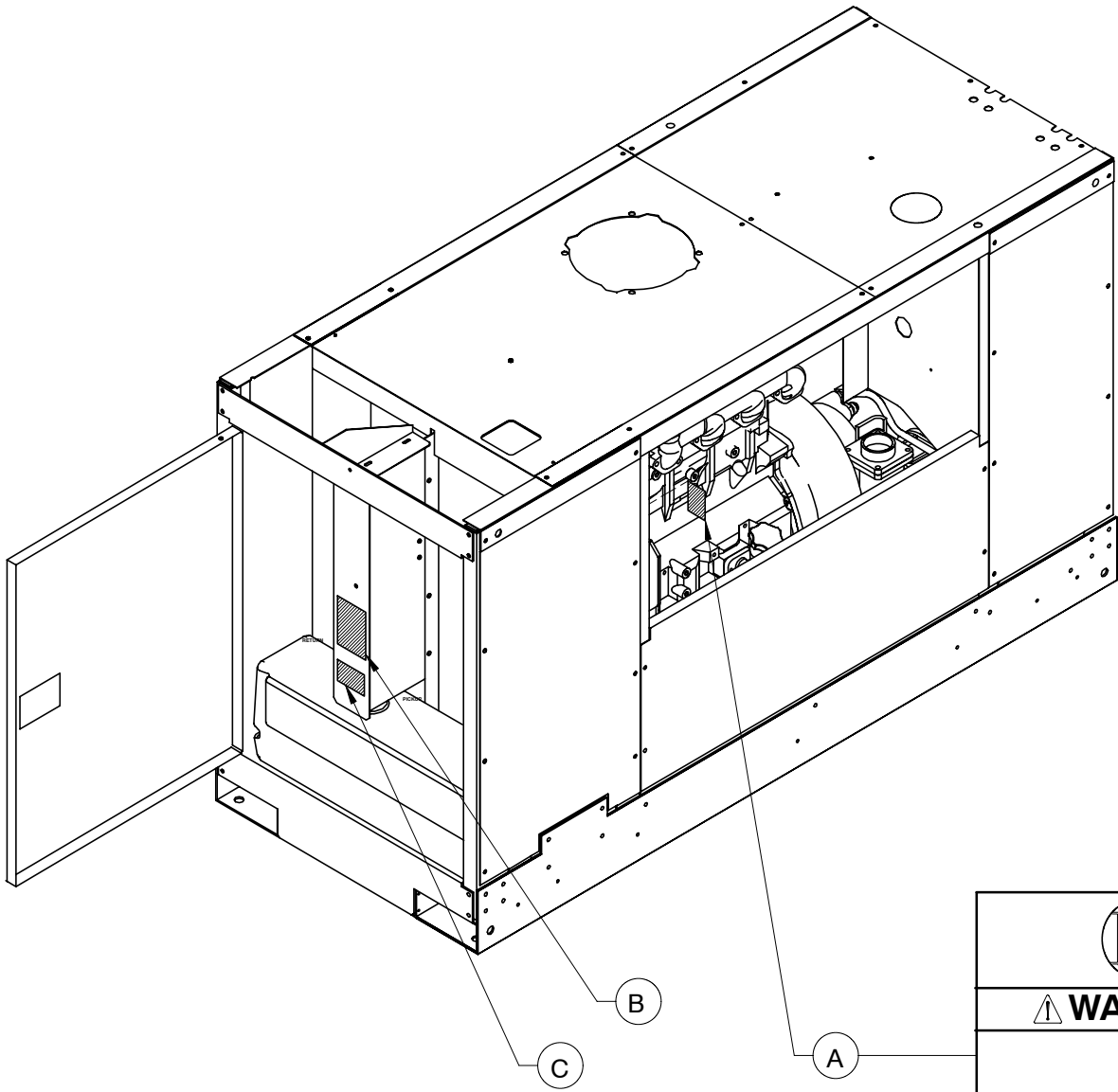



WARNING



Rotating fan blade.
Can cause serious injury.

Do not operate without guard
 in place.

Ingersoll-Rand 54568779 REV. A

BEGIN WITH SERIAL NUMBER 326650

INGERSOLL-RAND COMPANY		
PORTABLE COMPRESSOR DIVISION		
DATE/DWN BY:	DESCRIPTION	
6/18/97	bd DECAL LOCATION	
MODEL NO.	MANUAL NO.	DATE/REV:
P-130AWJDU - P-185AWJDU	35393065-48	2/02 E

ITEM	C.P.N.	DESCRIPTION
A	54568779	DECAL, ROTATING FAN
B	54604962	DECAL, RAD FILL HOT
C	54625207	DECAL, DIESEL FUEL

BEGIN WITH SERIAL NUMBER 326650

INGERSOLL-RAND COMPANY		
PORTABLE COMPRESSOR DIVISION		
DATE/DWN BY:	DESCRIPTION	
6/18/97	bd	DECAL LOCATION
MODEL NO.	MANUAL NO.	DATE/REV:
P-130AWJDU - P-185AWJDU	35393065-49	12/00 D

SECTION 11 - OPTIONS LIST

Cold Start, Auto JD

Cold Start, Manual

Diagnostic Module

Gauge, Tachometer

Generator Assembly

Side Hinge Hose Reel Assembly

Indicator, Electric Air Filter

Indicator, Separator Delta

Valve, Minimum Pressure

Valve Assembly, Minimum Pressure

Valve, Electric Start Run

Schematic, Cold Start Wiring

Schematic, Generator Wiring

Schematic, Hose Reel Wiring

Parts, Miscellaneous Option

Central Drains w/ Valves

Top Hinge Hose Reel Assembly

Dual Regulation

Schematic, 110v Heater Wiring

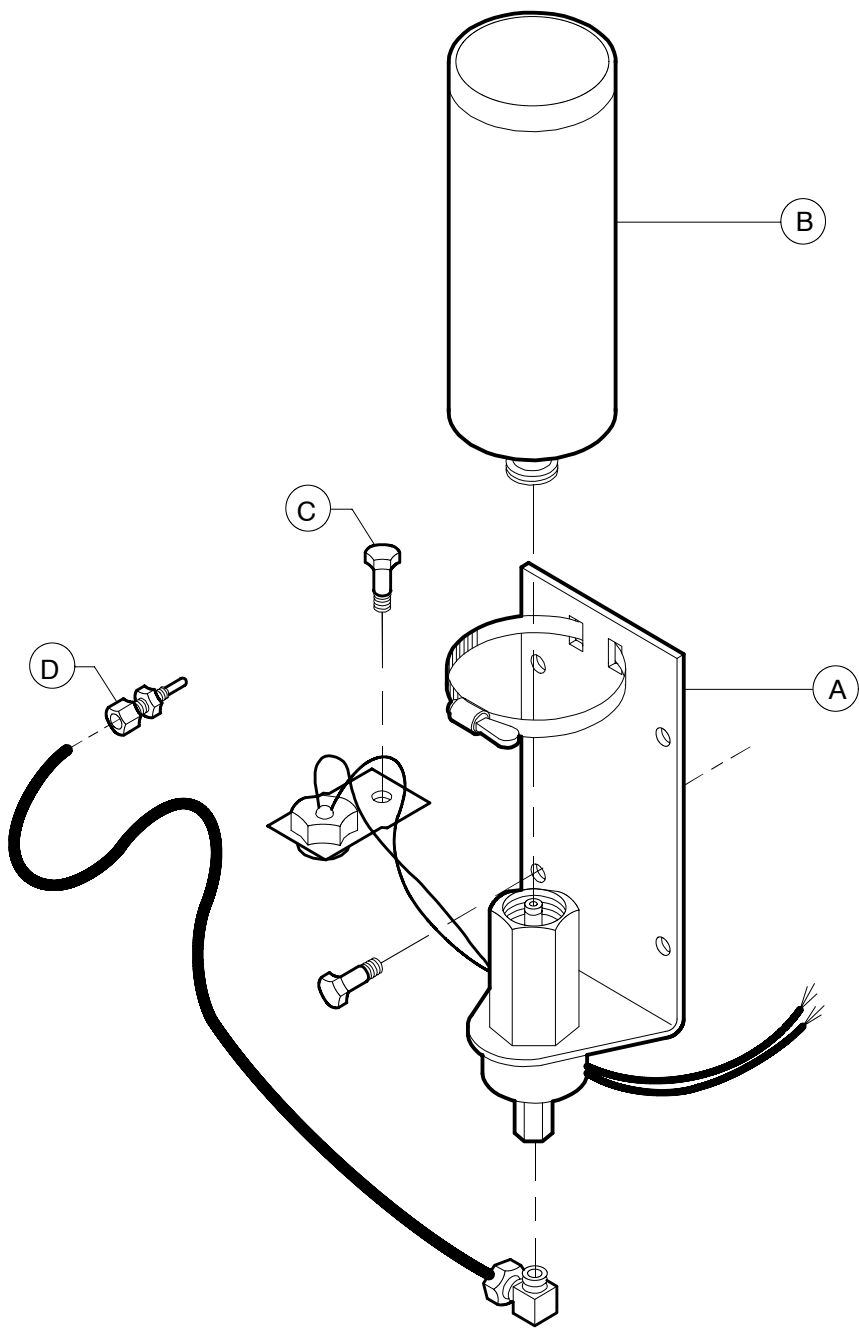

35393065-02		INGERSOLL-RAND COMPANY	
35393628-02		PORTABLE COMPRESSOR DIVISION	
DATE/DWN BY:	DESCRIPTION		
8/01/97 bc	AUTO COLD START (JD)		
MODEL NO.	MANUAL NO.	DATE/REV:	
	OPTION	4/98 A	

ITEM	C.P.N.	QTY	DESCRIPTION
A	* 35377266	1	KIT, COLD START
B	36796910	1	CYLINDER, ETHER
C	96701479	1	SCREW, HEX M10-1.5 X 16
D	36889384	1	BUSHING

* SEE WIRING SCHEMATIC FOR COLD START KIT

35393065-03		INGERSOLL-RAND COMPANY PORTABLE COMPRESSOR DIVISION	
35393628-03			
DATE/DWN BY:	DESCRIPTION		
8/01/97 bc	AUTO COLD START (JD)		
MODEL NO.	MANUAL NO.	DATE/REV:	
	OPTION	4/98	A

ITEM	C.P.N.	QTY	DESCRIPTION
A	35367739	1	KIT, COLD START
B	35112911	1	CYLINDER, ETHER
C	36842821	1	HARNESS, COLD START
D	92368687	2	SCREW, HEX M06-100 X 14
E	36889384	1	BUSHING
F	35315027	1	ATOMIZER
G	35306141	2	TERMINAL, CONNECTOR
H	36879708	1	PANEL, SWITCH BEZEL
J	* 35367747	1	VALVE
K	* 35103506	1	CLAMP
L	36882207	2	SCREW, PAN HD M06-1.0 X 12
M	96700851	2	NUT, HEX M06-1.0
N	36879955	1	DECAL, ETHER
P	36887636	1	PLUG, HOLE 9/16

* INCLUDED IN COLD START KIT

35393065-05		INGERSOLL-RAND COMPANY	
35393628-05		PORTABLE COMPRESSOR DIVISION	
DATE/DWN BY:	DESCRIPTION		
8/01/97	bc MAN COLD START OPT		
MODEL NO.	MANUAL NO.	DATE/REV:	
	OPTION	4/98	A

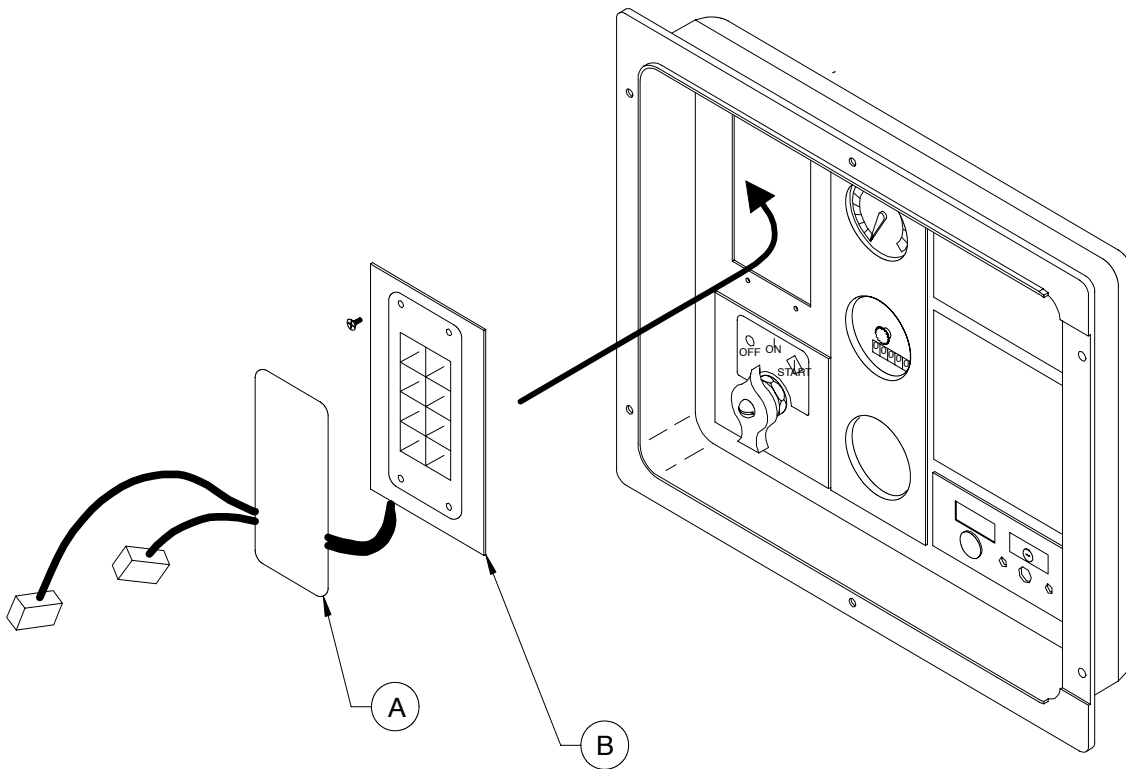

35393065-06		INGERSOLL-RAND COMPANY	
35393628-06		PORTABLE COMPRESSOR DIVISION	
DATE/DWN BY:	DESCRIPTION		
7/22/97 bc	DIGN DISPLAY MODULE		
MODEL NO.	MANUAL NO.	DATE/REV:	
	OPTION	4/98	A

ITEM	C.P.N.	QTY	DESCRIPTION
A	36879674	1	DECAL, DIAGNOSTIC
B	36882033	1	MODULE, DIAGNOSTIC

35393065-07		INGERSOLL-RAND COMPANY PORTABLE COMPRESSOR DIVISION	
35393628-07			
DATE/DWN BY:	DESCRIPTION		
7/22/97	bc DIGN DISPLAY MODULE		
MODEL NO.	MANUAL NO.	DATE/REV:	
	OPTION	4/98	A

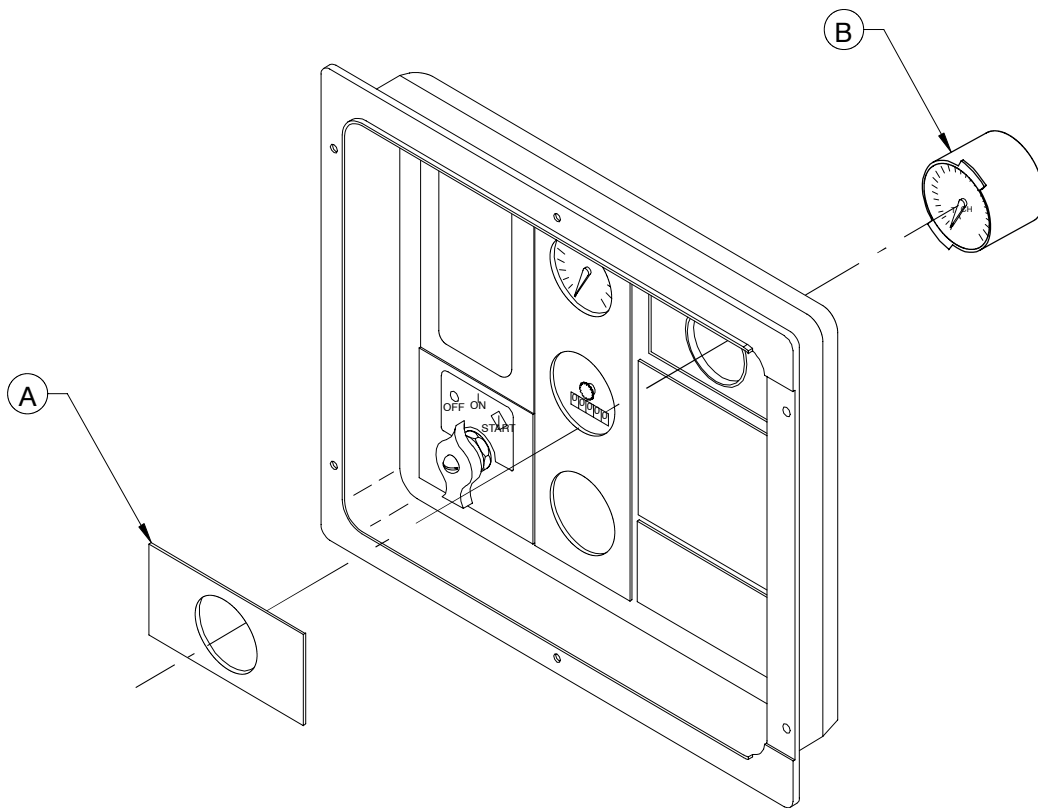

35393065-08		INGERSOLL-RAND COMPANY	
35393628-08		PORTABLE COMPRESSOR DIVISION	
DATE/DWN BY:	7/22/97	bc	DESCRIPTION TACHOMETER OPTION
MODEL NO.		MANUAL NO. OPTION	DATE/REV: 4/98 A

ITEM	C.P.N.	QTY	DESCRIPTION
------	--------	-----	-------------

A	36879914	1	PANEL, BEZEL
B	36879740	1	TACHOMETER

35393065-09 35393628-09	INGERSOLL-RAND COMPANY PORTABLE COMPRESSOR DIVISION		
	DATE/DWN BY:	DESCRIPTION	
	7/22/97 bc	TACHOMETER OPTION	
MODEL NO.	MANUAL NO.	DATE/REV:	
	OPTION	4/98 A	

ITEM	C.P.N.	QTY	DESCRIPTION
A	36892487	1	DOOR, CURB SIDE
B	36892511	1	BRACKET, GENERATOR
C	36892529	1	BRACKET, GENERATOR
D	35271162	2	SCREW, FLANGE HEAD M08-1.25 x 30
E	36884427	1	GENERATOR
F	95935227	2	SCREW, HEX 5/16-18 X 1.25 (P100-P175)
	36793040	2	SCREW, FLANGE HEAD M16-2.0 X 40 (P185)
G	96701917	1	SCREW, HEX M10-1.50 X 30
H	36879195	1	NUT, HEX FLANGE M10-1.50
J	36880886	2	SCREW, HEX FLANGE M08-1.25
K	35611391	1	STRAP, ADJ ALTERNATOR
L	36893626	1	BOX, CONTROL
M	36787414	1	RELIEF, STRAIN
N	36797652	6	SCREW, TAPPING M06-1.0 X 12
P	36892610	1	BELT, V 7/16 X 36
Q	95929006	1	SCREW, HEX 5/16-18 X 1
R	36531937	1	DECAL, PINCH POINT
S	36532018	1	DECAL, VERT 3-PART DANGER
T	36532026	2	DECAL, HORIZ HAZ VOLTAGE
U	36891604	1	DECAL, GEN OPERATING INST
V	36896165	1	PULLEY, CRANKSHAFT (P130 & P175)
	36895233	1	PULLEY, CRANKSHAFT (P185)
W	95055349	4	SCREW, CAP SHOULDER 3/8-16 X 1

** SUPPLIED WITH GENERATOR

35393065-11		INGERSOLL-RAND COMPANY	
35393628-11		<small>PORTABLE COMPRESSOR DIVISION</small>	
<small>DATE/DWN BY:</small>	<small>DESCRIPTION</small>		
8/12/97 bc	GENERATOR ASSEMBLE		
<small>MODEL NO.</small>	<small>MANUAL NO.</small>	<small>DATE/REV:</small>	
	OPTION	12/98 D	

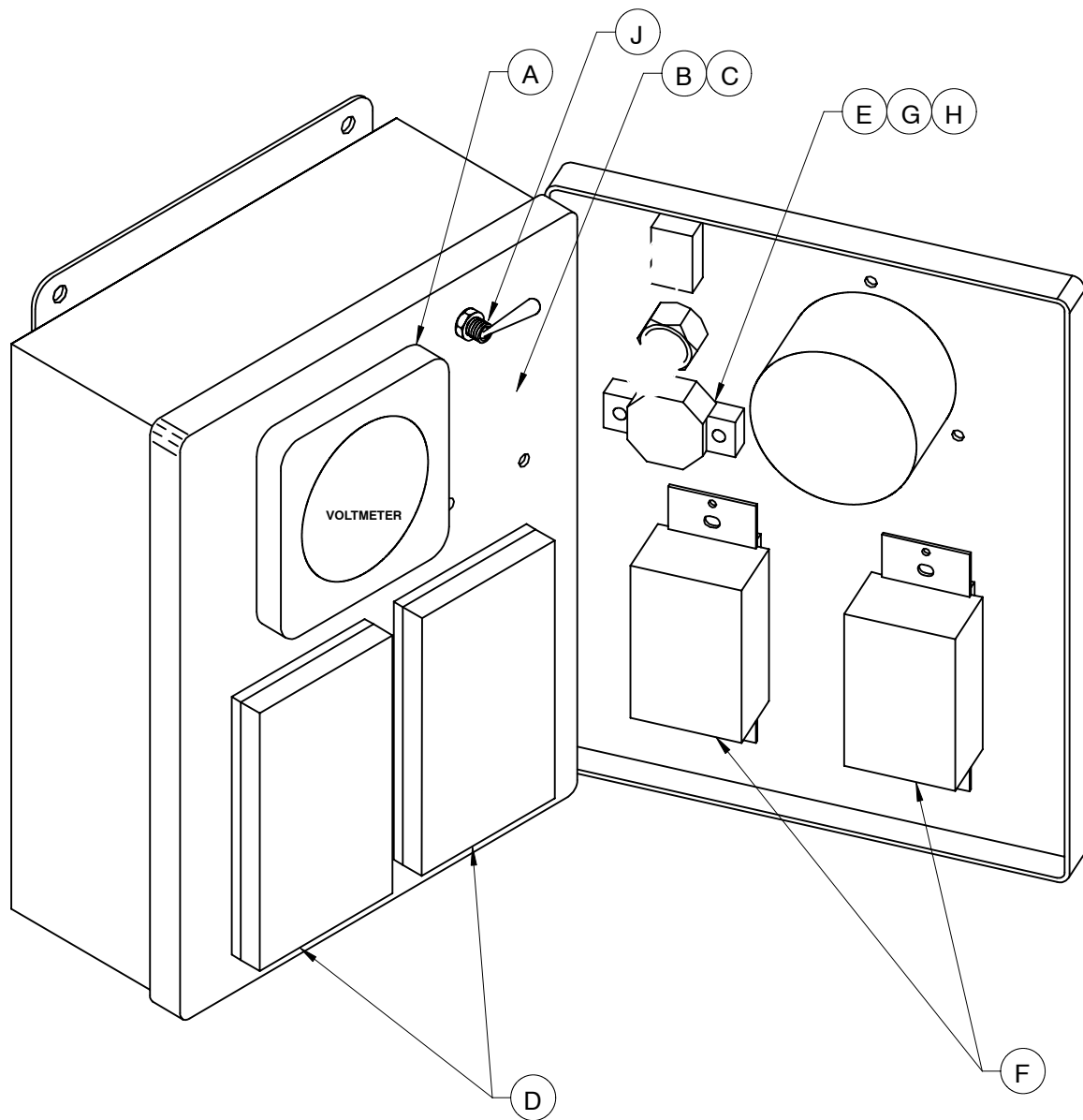

35393065-12		INGERSOLL-RAND COMPANY	
35393628-12		PORTABLE COMPRESSOR DIVISION	
DATE/DWN BY:	DESCRIPTION		
8/12/97 bc	GENERATOR ASSEMBLE		
MODEL NO.	MANUAL NO.	DATE/REV:	
	OPTION	4/98	B

ITEM	C.P.N.	QTY	DESCRIPTION
A	36884435	1	METER, VOLT 0-15
B	36883825	1	LAMP, HOLDER RED
C	35333236	1	BULB, INCAND 12V
D	36862258	2	COVER, RECEPTACLE GFI
E	36892560	1	BREAKER, CIRCUIT
F	36848745	2	RECEPTACLE, DUPLEX 125V
G	95942603	2	SCREW, PAN HEAD #10-32 X 3/4
H	95923124	2	NUT, HEX #10-32
J	36892545	1	SWITCH, 3 POSITION

35393065-13		INGERSOLL-RAND COMPANY	
35393628-13		PORTABLE COMPRESSOR DIVISION	
DATE/DWN BY:	DESCRIPTION		
8/12/97 bc	GENERATOR ASSEMBLE		
MODEL NO.	MANUAL NO.	DATE/REV:	
	OPTION	4/98 B	

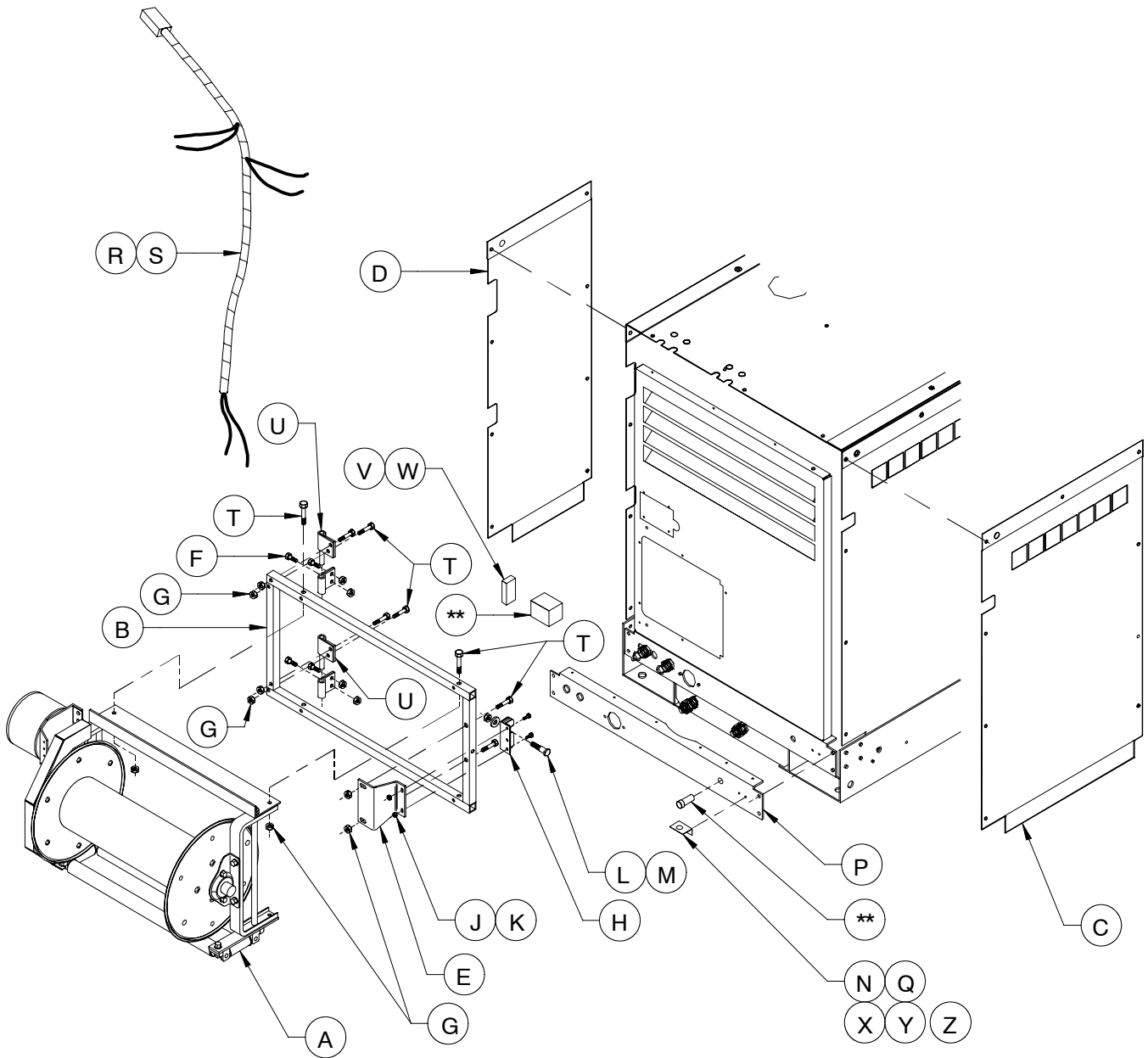

35393065-14		INGERSOLL-RAND COMPANY	
35393628-14		PORTABLE COMPRESSOR DIVISION	
DATE/DWN BY:	7/29/97	DESCRIPTION	bc HOSE REEL ASSEMBLY
MODEL NO.		MANUAL NO.	OPTION
		DATE/REV:	4/98 B

ITEM	C.P.N.	QTY	DESCRIPTION
A	36892586	1	HOSE REEL ASSEMBLY
B	36891638	1	FRAME, HOSE REEL
C	36892404	1	PANEL, CAB SIDE
D	36892412	1	PANEL, BED SIDE
E	36894236	1	BRACKET, LATCH MOUNTING
F	36880995	4	SCREW, HEX FLANGE HD M10-1.5 X 30
G	36879195	16	NUT, HEX FLANGE M10-1.5
H	36894228	1	LATCH, SLAM
J	36769024	3	SCREW, HEX M06-1.0 X 20
K	96700851	3	NUT, HEX M06-1.0
L	36891620	1	PIN, STRIKER
M	95993485	1	NUT, HEX 7/16-14
N	92368687	2	SCREW, TAPPING M06-1.0 X 14
P	36892537	1	FRAME, DOOR LOWER CURB
Q	35296748	1	BRACKET, HOSE REEL LOCK
R	36793008	1	RELIEF, STRAIN
S	36892420	1	HARNESS, H.R.WIRING
T	36766343	16	SCREW, HEX M10-1.5 X 60
U	36891604	2	HINGE, LIFT-OFF
V	35249721	2	SCREW, SELF TAPPING 08-32 X .60
W	36884633	1	BREAKER, CIRCUIT
X	35221910	1	LOCK, COUPLING HOSE (STD HOSE)
	35358506	1	COUPLING, HOSE 1/2 NPT (THOR CPLGS)
Y	95928321	2	WASHER, FLAT
Z	35153972	1	CAP, HOSE LOCK

** SUPPLIED WITH HOSE REEL

35393065-15		INGERSOLL-RAND COMPANY	
35393628-15		PORTABLE COMPRESSOR DIVISION	
DATE/DWN BY:	DESCRIPTION		
7/29/97	bc HOSE REEL ASSEMBLY		
MODEL NO.	MANUAL NO.	DATE/REV:	
	OPTION	4/98 B	

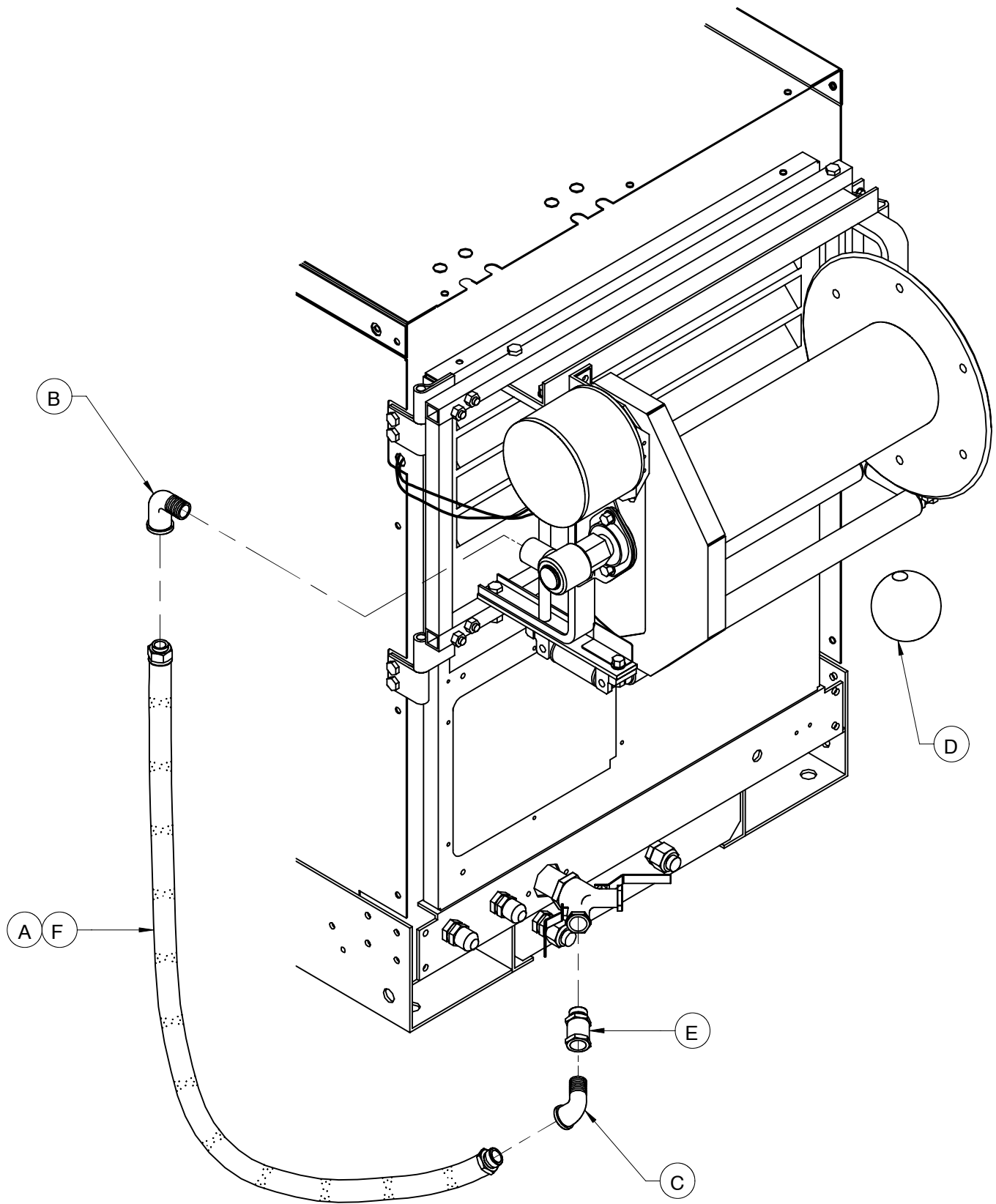

35393065-16		INGERSOLL-RAND COMPANY	
35393628-16		PORTABLE COMPRESSOR DIVISION	
DATE/DWN BY:	7/29/97	bc	DESCRIPTION HOSE REEL ASSEMBLY
MODEL NO.		MANUAL NO.	DATE/REV: OPTION 4/98 B

ITEM	C.P.N.	QTY	DESCRIPTION
A	36892636	1	HOSE ASSEMBLY
B	95928198	1	ELBOW, STREET NPT 3/4 X 45°
C	95928172	1	ELBOW, STREET NPT 3/4 X 90°
D	35378322	1	STOP, HOSE
E	35364371	1	VALVE, CHECK EXCESS FLOW (P130)
	35364397	1	VALVE, CHECK EXCESS FLOW (P175 - P185)
F	35114081	1	CLAMP, HOSE

35393065-17 35393628-17		INGERSOLL-RAND COMPANY PORTABLE COMPRESSOR DIVISION		
		DATE/DWN BY:	DESCRIPTION	
		7/29/97	bd	HOSE REEL ASSEMBLY
		MODEL NO.	MANUAL NO.	DATE/REV:
			OPTION	4/98 B

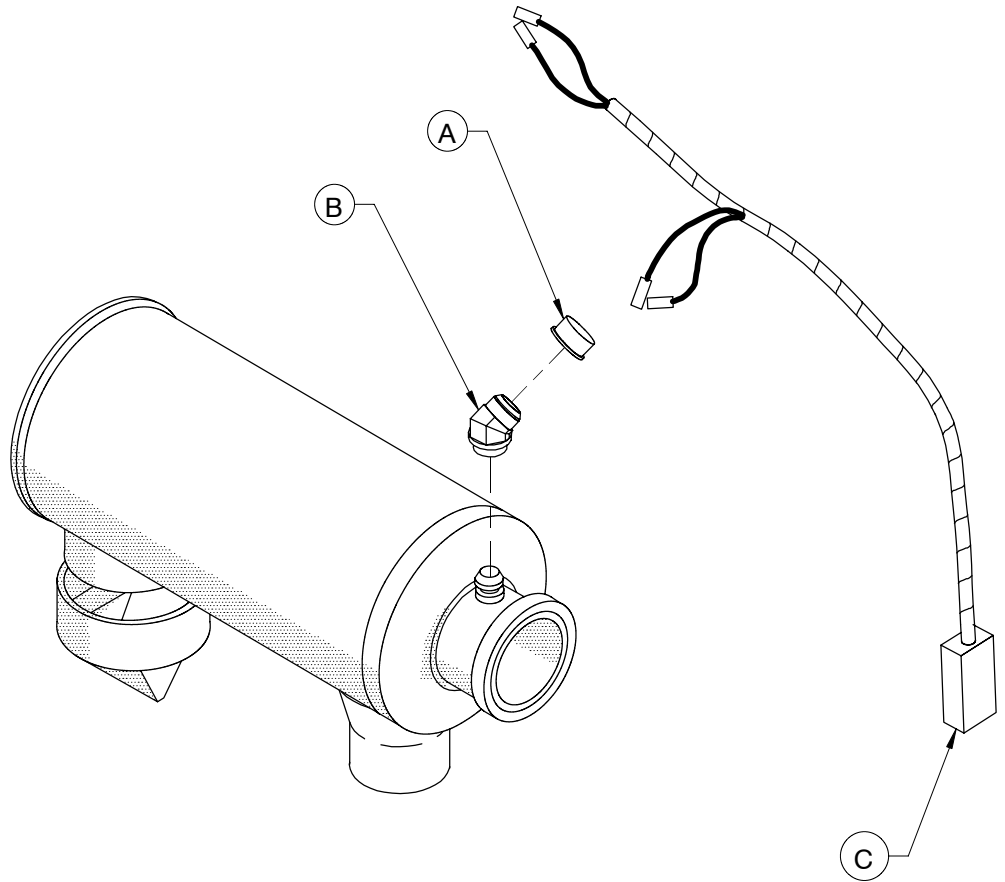

ELECTRIC AIR FILTER MAINTANCE INDICATOR OPTIONS

35393065-18	35391705-64	35390095-64	INGERSOLL-RAND COMPANY PORTABLE COMPRESSOR DIVISION		
35393628-18	35391713-64	35391093-64			
54437173-64	35391721-64	35392877-64	3/22/96	bd	ELECT AIR FLTR MAINT IND
	35391739-64	35392885-64	MODEL NO.	MANUAL NO.	DATE/REV:
	35392984-64	35393172-64		OPTION	8/97 A

ITEM	C.P.N.	QTY	DESCRIPTION
A	36847838	2	SWITCH, FILTER INDICATOR
B	95956199	2	ELBOW, 45° 1/8NPT
C	36842839	1	HARNESS, AFMI

ELECTRIC AIR FILTER MAINTANCE INDICATOR OPTIONS

35393065-19	35391705-65	35390095-65	INGERSOLL-RAND COMPANY PORTABLE COMPRESSOR DIVISION		
35393628-19	35391713-65	35391093-65			
54437173-65	35391721-65	35392877-65	DATE/DWN BY:	DESCRIPTION	
	35391739-65	35392885-65	3/22/96	bc	ELECT AIR FLTR MAINT IND
	35392984-65	35393172-65	MODEL NO.	MANUAL NO.	DATE/REV:
				OPTION	8/97 A

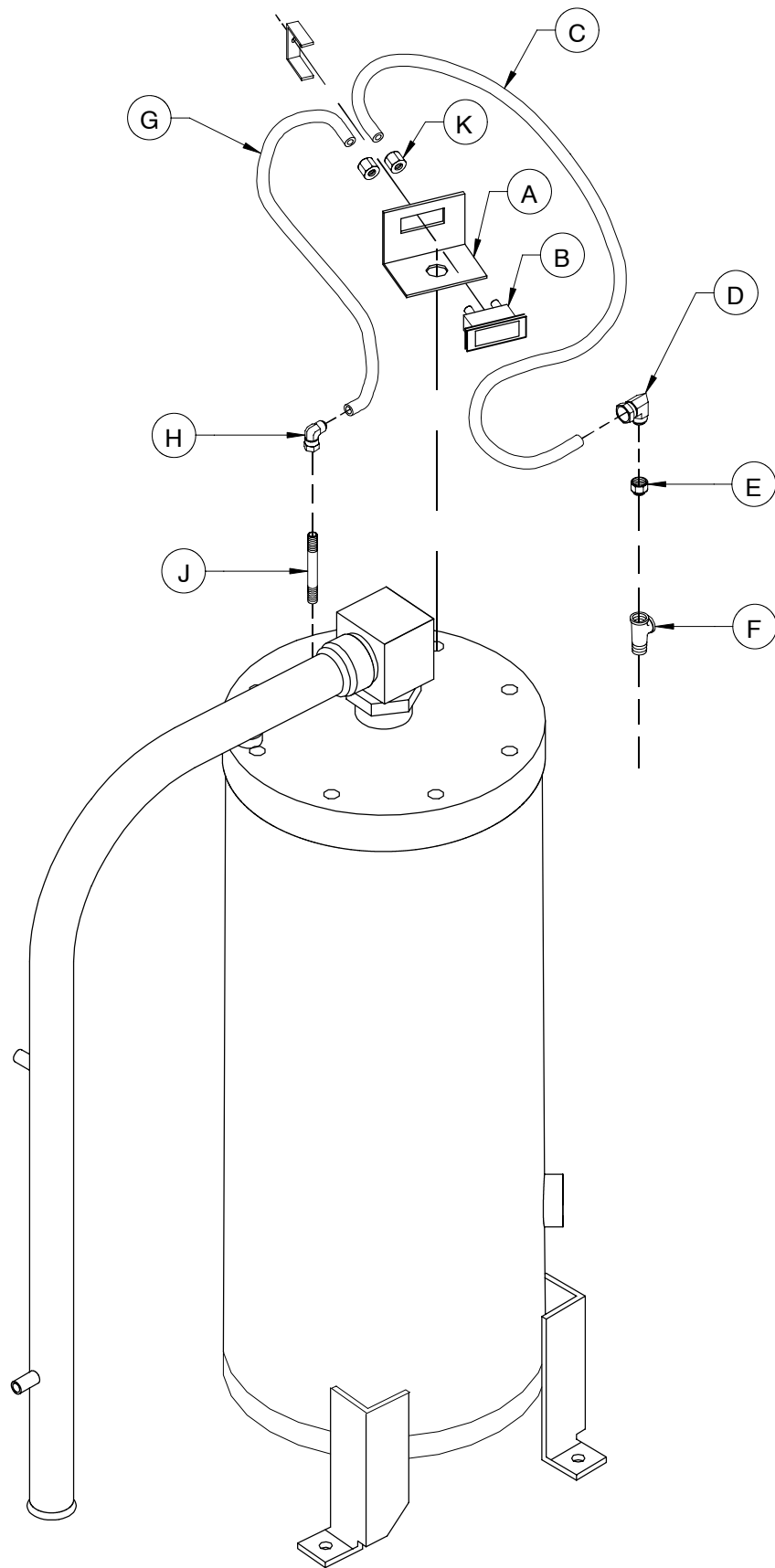

35393065-20		INGERSOLL-RAND COMPANY	
35393628-20		PORTABLE COMPRESSOR DIVISION	
DATE/DWN BY:	DESCRIPTION		
8/8/97 bc	SEP DELTA P INDICATOR		
MODEL NO.	MANUAL NO.	DATE/REV:	
	OPTION	4/98 A	

ITEM	C.P.N.	QTY	DESCRIPTION
A	36841922	1	BRACKET, SEP INDICATOR MOUNTING
B	35825546	1	INDICATOR, SEPARATOR ELEMENT
C	35356484	17"	TUBING, 3/8"
D	35369354	1	ELBOW, MALE 1/4 NPT X 3/8 TUBE
E	95944625	1	BUSHING, REDUCING
F	35301373	1	TEE, STREET 1/2 NPT
G	35356484	20"	TUBING, 3/8"
H	35377035	1	ELBOW, TUBING 3/8 X 1/4 NPT
J	95084059	1	NIPPLE, 1/4 NPT X 3
K	35379700	2	CONNECTOR 1/8NPT X 3/8 TUBE

35393065-21		INGERSOLL-RAND COMPANY	
35393628-21		PORTABLE COMPRESSOR DIVISION	
DATE/DWN BY:	DESCRIPTION		
8/8/97	bc SEP DELTA P INDICATOR		
MODEL NO.	MANUAL NO.	DATE/REV:	
P-130AWJDU - P-185AWJDU	OPTION	4/98 A	

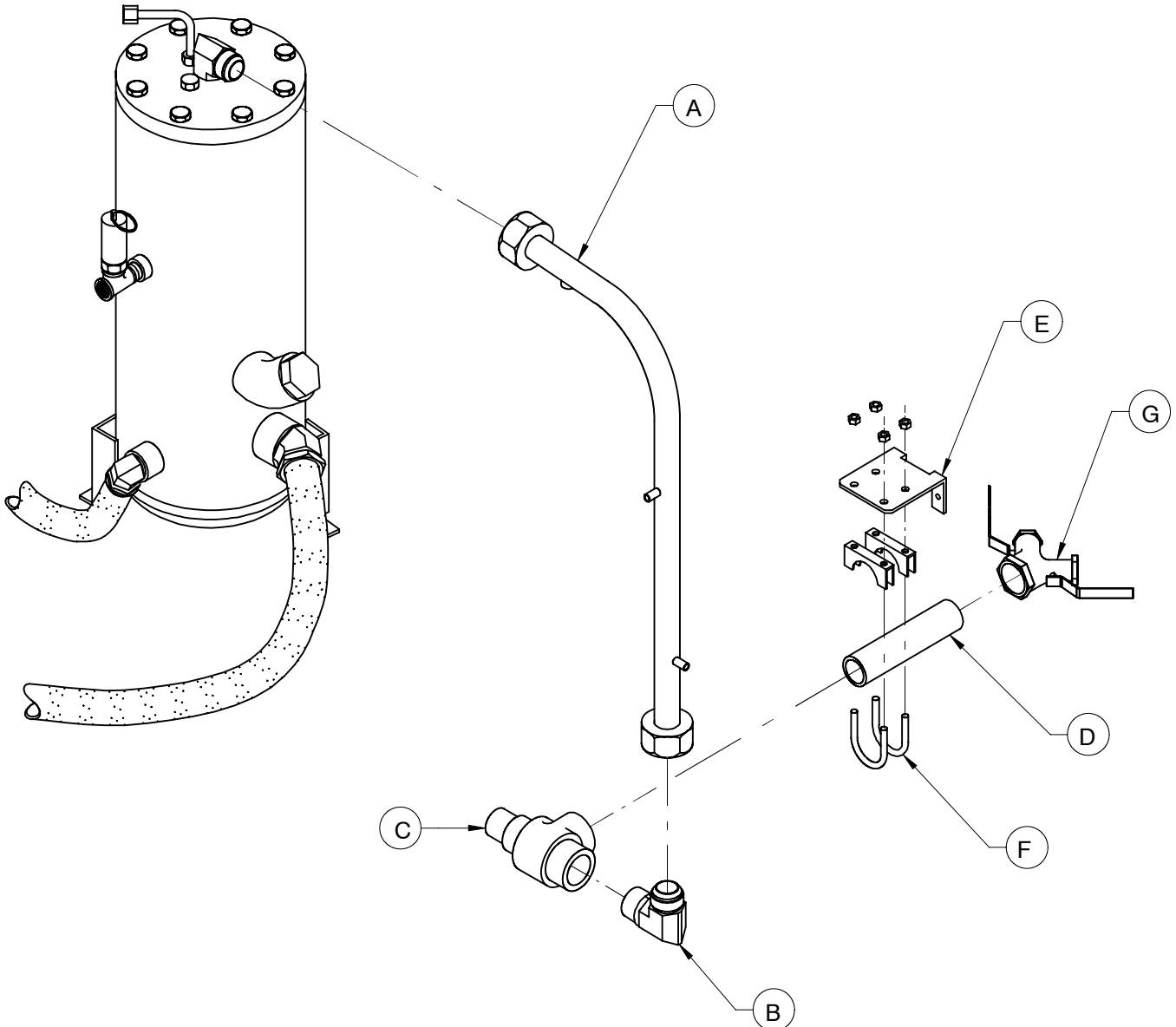

35393065-22		INGERSOLL-RAND COMPANY	
35393628-22		PORTABLE COMPRESSOR DIVISION	
DATE/DWN BY:	DESCRIPTION		
7/22/97	bc AIR SERVICE COMPLETE		
MODEL NO.	MANUAL NO.	DATE/REV:	
P-130AWJDU - P-185AWJDU	OPTION	4/98 A	

ITEM	C.P.N.	QTY	DESCRIPTION
A	36891505	1	TUBE, SERVICE
B	95219861	1	ELBOW, TUBE
C	36776219	1	VALVE, MIN PRESS
D	95916268	1	NIPPLE, 1.25 X 8
E	36890846	1	BRACKET, SERVICE PIPE
F	36785277	1	CLAMP, SADDLE 1.62 Ø
G	36881076	1	VALVE, WYE
H	95923314	4	NUT, HEX 5/16-18
J	35279025	2	SCREW, TAPPING M08-1.25 X 20

35393065-23 35393628-23	INGERSOLL-RAND COMPANY		
	PORTABLE COMPRESSOR DIVISION		
	DATE/DWN BY:	DESCRIPTION	
	7/22/97	bd AIR SERVICE COMPLETE	
MODEL NO.	MANUAL NO.	DATE/REV:	
P-130AWJDU - P-185AWJDU	OPTION	4/98 A	

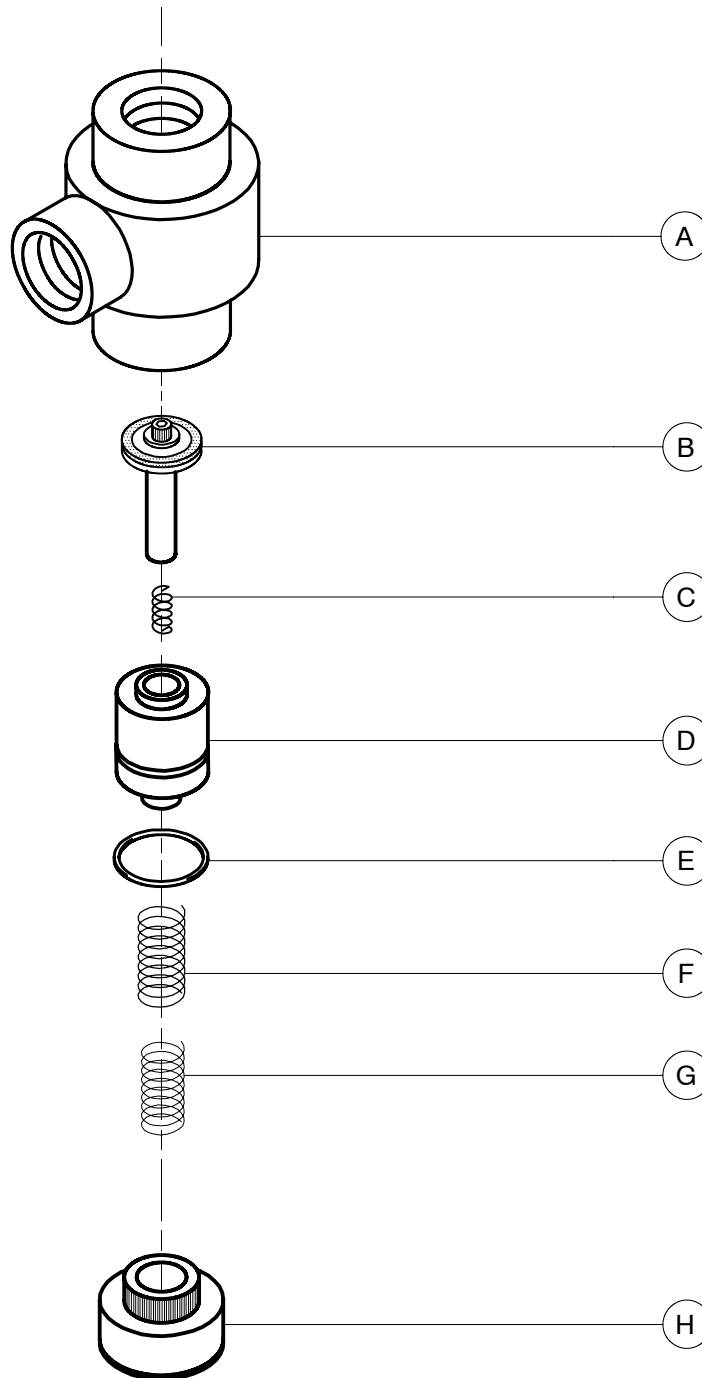

**MIN PRESS VALVE OPTION 36776219 FOR
P100WD/WJD - P185 WD/WJD, HP185WJD**

35393065-24 35393628-24	INGERSOLL-RAND COMPANY PORTABLE COMPRESSOR DIVISION		
	DATE/DWN BY:	DESCRIPTION	
	3/26/97 bc	MIN PRESS VALVE	
	MODEL NO.	MANUAL NO.	DATE/REV:
PLATINUM	OPTION	4/98 A	

ITEM	C.P.N.	QTY	DESCRIPTION
A	35382621	1	MIN PRESS VALVE BODY
B	35382639	1	CV ASSEMBLY
C	35382662	1	SPRING
D	35382647	1	PISTON
E	35382654	1	O-RING
F	35382670	1	SPRING
G	35389055	1	SPRING
H	35382688	1	CAP
	35598770	1	MIN PRESS VALVE ASSEMBLY

**MIN PRESS VALVE OPTION 36776219 FOR
P100WD/WJD - P185 WD/WJD, HP185WJD**

35393065-25 35393628-25	INGERSOLL-RAND COMPANY		
	PORTABLE COMPRESSOR DIVISION		
	DATE/DWN BY:	DESCRIPTION	
	3/26/97 bc	MIN PRESS VALVE	
MODEL NO.	MANUAL NO.	DATE/REV:	
PLATINUM	OPTION	4/98 A	

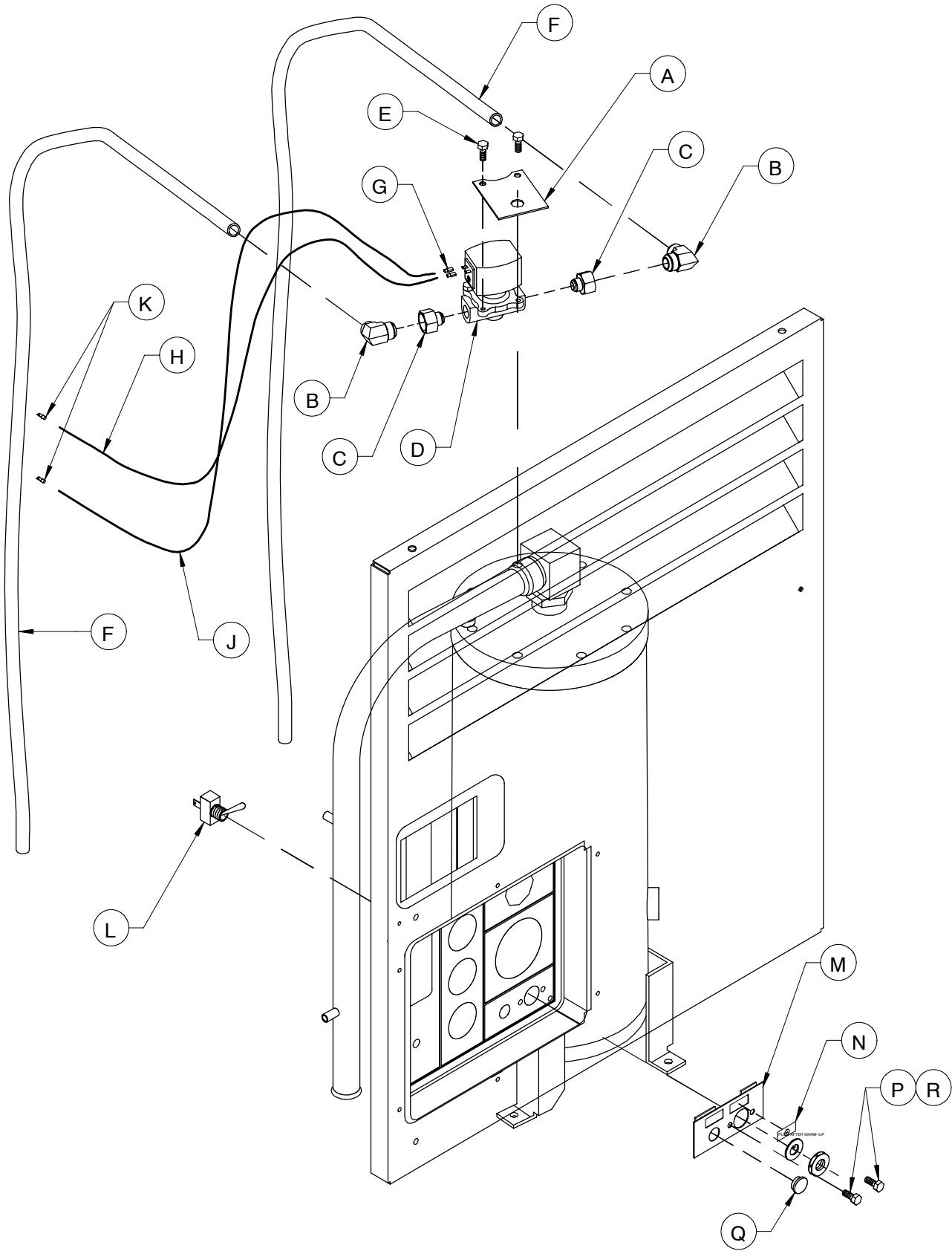

35393065-26		INGERSOLL-RAND COMPANY	
35393628-26		PORTABLE COMPRESSOR DIVISION	
DATE/DWN BY:	DESCRIPTION		
8/7/97	bc ELECTRIC START-RUN VALVE		
MODEL NO.	MANUAL NO.	DATE/REV:	
	OPTION	4/98 A	

ITEM	C.P.N.	QTY	DESCRIPTION
A	36892669	1	BRACKET, SOLENOID VALVE
B	35369354	2	ELBOW, MALE 1/4NPT X 3/8 TUBE
C	95940748	2	BUSHING, REDUCING
D	36843142	1	SLOENOID, 12 VDC
E	95928982	2	SCREW, HEX 1/4-20 X 3/4
F	35356484	2	TUBING, 3/8 SYNDFLEX (44" EA.)
G	36844520	2	CONNECTOR, 1/4 FEMALE
H	35360916	30"	WIRE, 14 GA. ORANGE
J	35307685	30"	WIRE, 14 GA. BROWN
K	35306141	2	CONNECTOR, 1/4 MALE
L	36895449	1	SWITCH, 3 POSITION TOGGLE
M	36879708	1	PANEL, SWITCH BEZEL
N	36532992	1	DECAL, START/RUN
P	36882207	2	SCREW, PAN HD M06-1.0 X 12
Q	35282185	1	PLUG, HOLE
R	96700851	2	NUT, HEX M06-1.0

35393065-27		INGERSOLL-RAND COMPANY	
35393628-27		PORTABLE COMPRESSOR DIVISION	
DATE/DWN BY:	DESCRIPTION		
8/7/97	bc	ELECTRIC START-RUN VALVE	
MODEL NO.	MANUAL NO.	DATE/REV:	
	OPTION	4/98 B	

NOTE:

1. WIRE FUSE INTO CIRCUIT AS CLOSE TO **M (MOTOR)** TERMINAL AS POSSIBLE.
2. **NOT** FOR USE WITH INGERSOLL ENGINES.

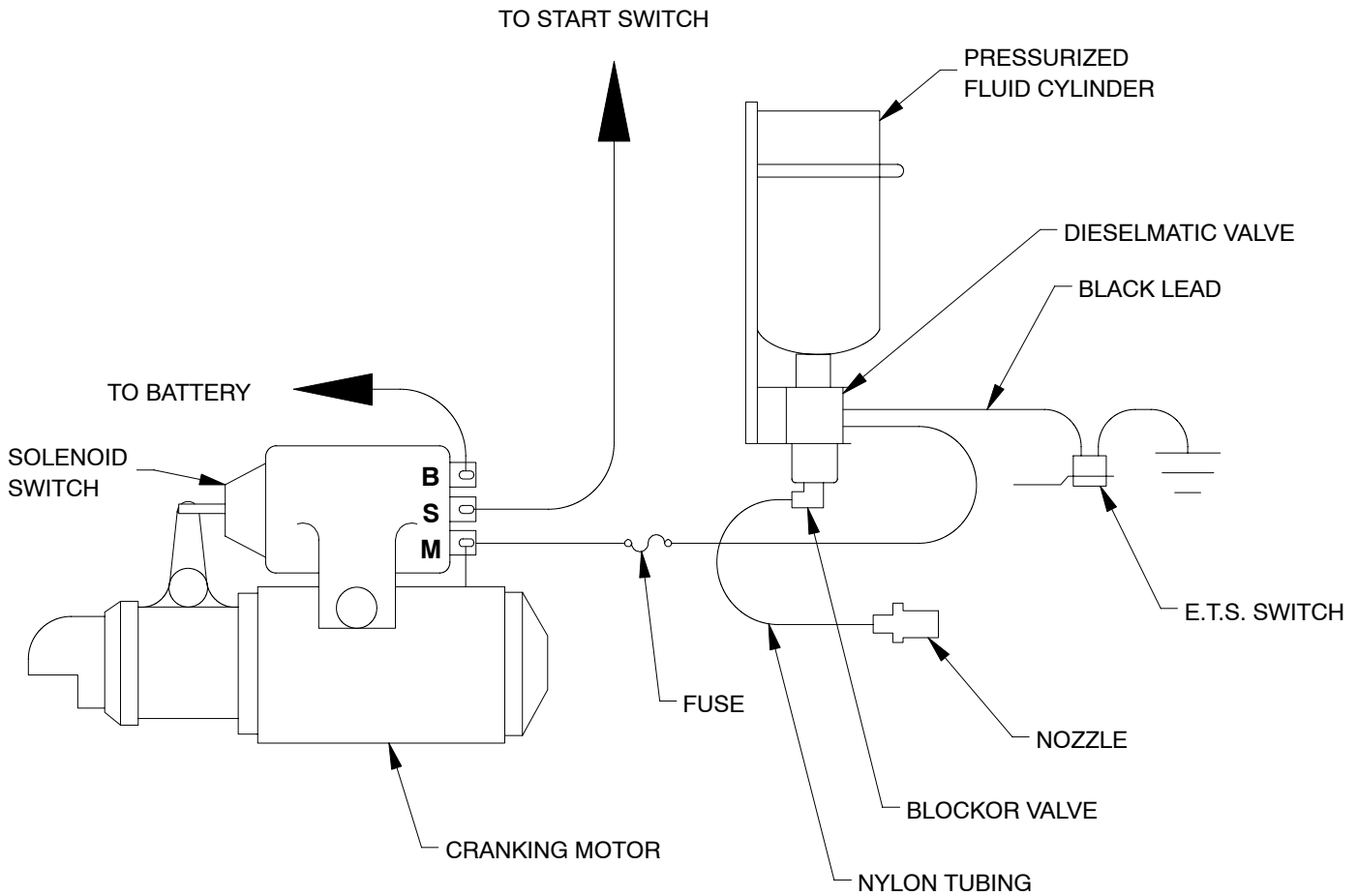

COLD START WIRING FOR KIT 35377266

35380277-42	35391825-82	35390095-76	INGERSOLL-RAND COMPANY PORTABLE COMPRESSOR DIVISION		
35393396-42	35391713-82	35391093-76			
35393065-28	35391721-82	35392877-76	DATE/DWN BY:	DESCRIPTION	
35393628-28	35391739-82	35392885-76	4/12/96	bc	COLD START WIRING
54437173-82	35392984-82	35393172-76	MODEL NO.	MANUAL NO.	DATE/REV:
				OPTION	11/97 A

- 1] INSTALLATION OF PMVR 120 REGULATOR:
- A. CONNECT DOUBLE BRN WIRE LEADS OF VOLTAGE REGULATOR AS FOLLOWS:
 ONE LEAD TO SILVER SCREW OF DOUBLE RECEPTACLE IN CONTROL BOX.
 OTHER LEAD TO BRASS SCREW.
 - B. CONNECT RED WIRE TO YELLOW WIRE (HOT +12 V SOURCE), AND TO PILOT LAMP TERMINAL.
 - C. CONNECT BLUE WIRE TO GREEN WIRE OF ALTERNATOR WITH BUTT SPLICE.
 - D. CONNECT BLACK WIRE TO BATTERY NEG.

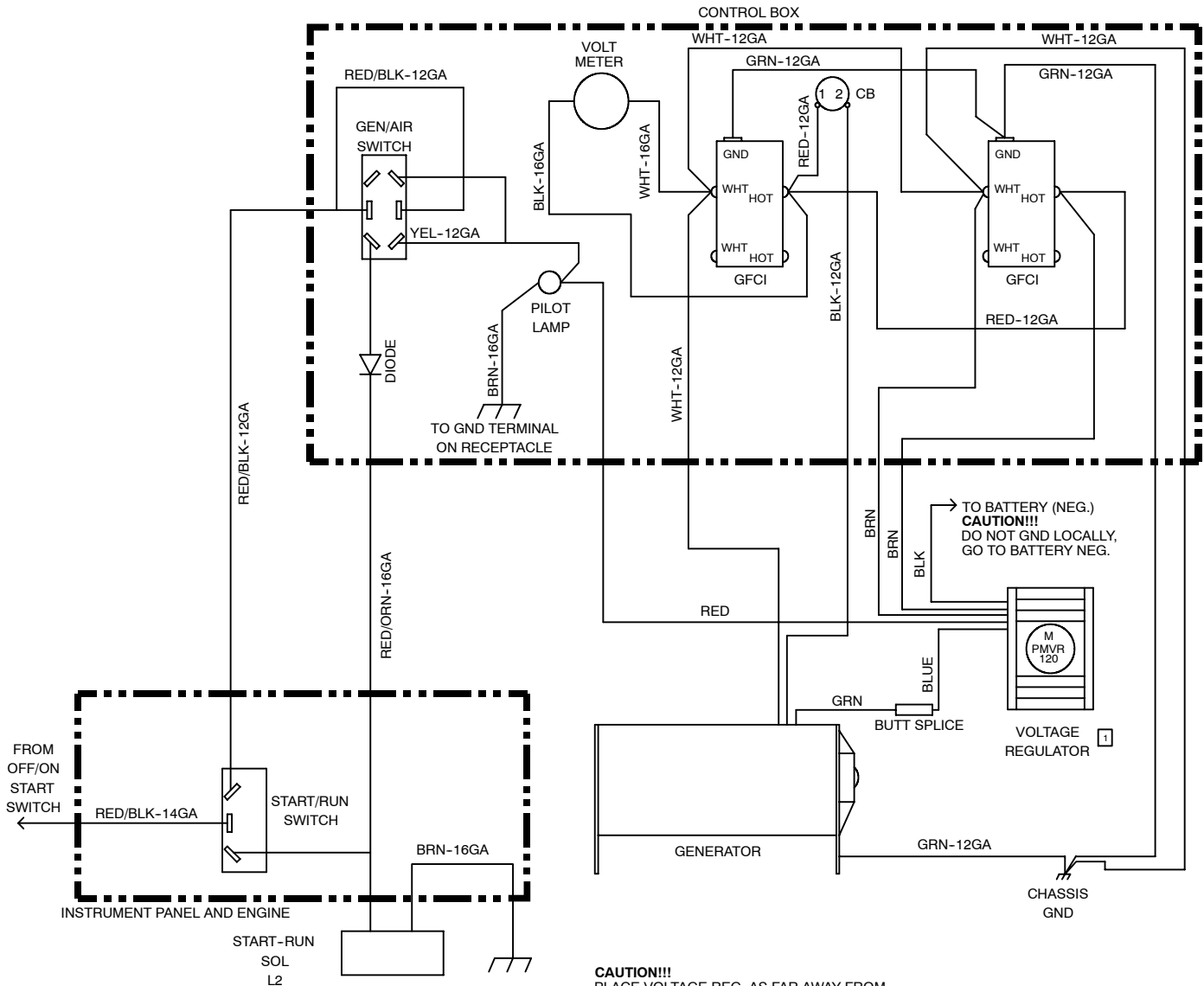

CAUTION!!!
 PLACE VOLTAGE REG. AS FAR AWAY FROM HEAT SOURCE AS POSSIBLE, AND IN THE AIR-STREAM WITH HOLES FACING AIR FLOW, IF POSSIBLE.

35393065-29	35391705-92	INGERSOLL-RAND COMPANY PORTABLE COMPRESSOR DIVISION	
35393628-29	35391713-92		
54437173-92	35391721-92	DATE/DWN BY:	DESCRIPTION
	35391739-92	8/20/97 bc	GENERATOR WIRING
	35392984-92	MODEL NO.	MANUAL NO.
		PLATINUM	OPTION
			DATE/REV:
			10/98 C

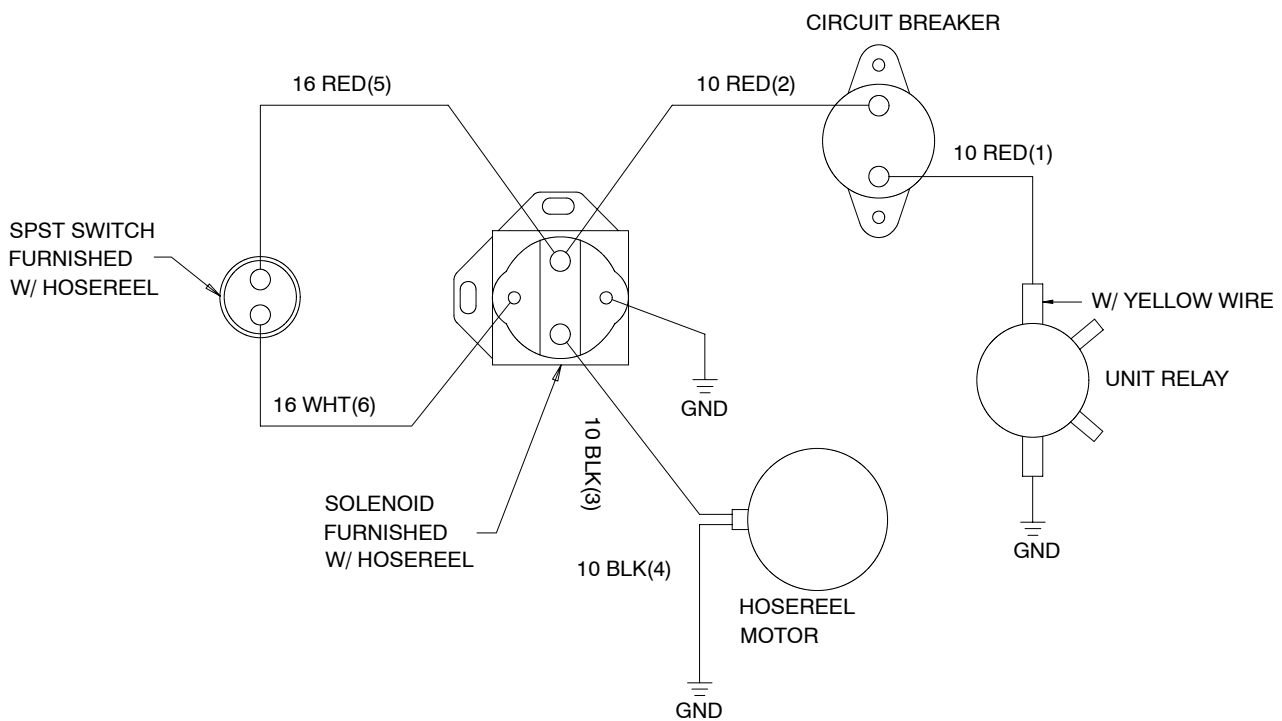

HOSE REEL WIRING FOR ELECTRIC HOSE REEL OPTION

35393065-30		INGERSOLL-RAND COMPANY	
35393628-30		PORTABLE COMPRESSOR DIVISION	
DATE/DWN BY:	8/01/97	DESCRIPTION	bc HOSE REEL WIRING
MODEL NO.		MANUAL NO.	OPTION
		DATE/REV:	4/98 A

C.P.N.	DESCRIPTION
--------	-------------

35610500	SPARK ARRESTOR (J DEERE)
36897296	ELBOW, EXHAUST
35314939	SWITCH, AIR RESTRICTION INDICATOR (ON AIR FILTERS)
95916243	COUPLING, 1/8 NPT X 13/16
9593493	NIPPLE, CLOSED 1/8 NPT X 3/4
36843563	ENGINE BLOCK HEATER (3 CYL. J DEERE)
35379221	ENGINE BLOCK HEATER (4 CYL. J DEERE)
36780252	KEY IGNITION SWITCH
36886810	GAGE LIGHT HARNESS
36843043	LIGHT, PANEL
35333236	BULB
36794345	KEY LOCK CYLINDER
35612746	KEY (REPLACEMENT)
35255025	OILER, 1 QUART
36893139	SEPARATOR, FUEL / WATER
36844975	BATTERY, 1000 CCA
36891976	STRAINER, FUEL TANK
36856979	RELAY, LOW FUEL SHUTDOWN
36892644	PUMP, ELECTRIC FUEL
36797652	SCREW, TAPPING M06-1.0 X 12
36840627	ADAPTER, BARBED
35363498	HOSE, .31 FUEL
35296342	CLAMP
36845493	FILTER, FUEL
35321637	ELEMENT, SAFETY
35291475	NUT, AIR CLEANER
36896157	GUARD, VANDAL
35279025	SCREW, TAPPING M08-1.25 X 20

35393065-31 35393628-31	INGERSOLL-RAND COMPANY		
	PORTABLE COMPRESSOR DIVISION		
	DATE/DWN BY: 7/31/97	bc	DESCRIPTION MISCELANEOUS OPTIONS
MODEL NO.	MANUAL NO. OPTION	DATE/REV: 4/98 C	

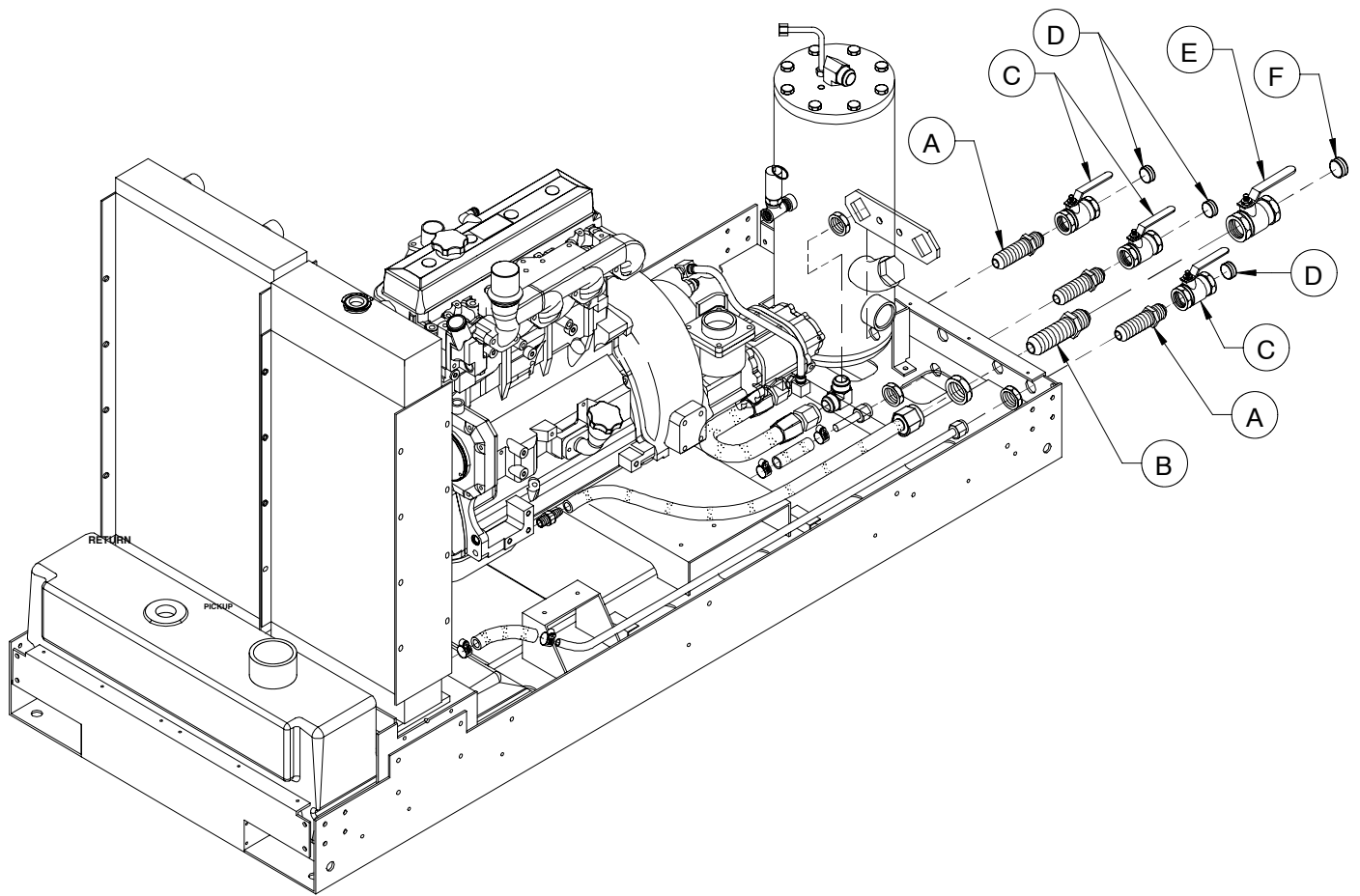

35393065-32		INGERSOLL-RAND COMPANY	
35393628-32		PORTABLE COMPRESSOR DIVISION	
DATE/DWN BY:	DESCRIPTION		
12/1/97	bc	CENTRAL DRAINS w/ VALVES	
MODEL NO.	MANUAL NO.	DATE/REV:	
P-130AWJDU - P-185AWJDU	OPTION	4/98 A	

	C.P.N.	QTY	DESCRIPTION
A	35285451	3	UNION, BULKHEAD
B	36895522	1	UNION, BULKHEAD
C	36895530	3	VALVE, BALL
D	95928255	3	PLUG, HEX COUNTERSINK
E	36895548	1	VALVE, BALL
F	95947149	1	PLUG, HEX COUNTERSINK

35393065-33 35393628-33	INGERSOLL-RAND COMPANY PORTABLE COMPRESSOR DIVISION		
	DATE/DWN BY:	DESCRIPTION	
	12/1/97	bc	CENTRAL DRAINS w/ VALVES
MODEL NO.	MANUAL NO.	DATE/REV:	
P-130AWJDU - P-185AWJDU	OPTION	4/98 A	

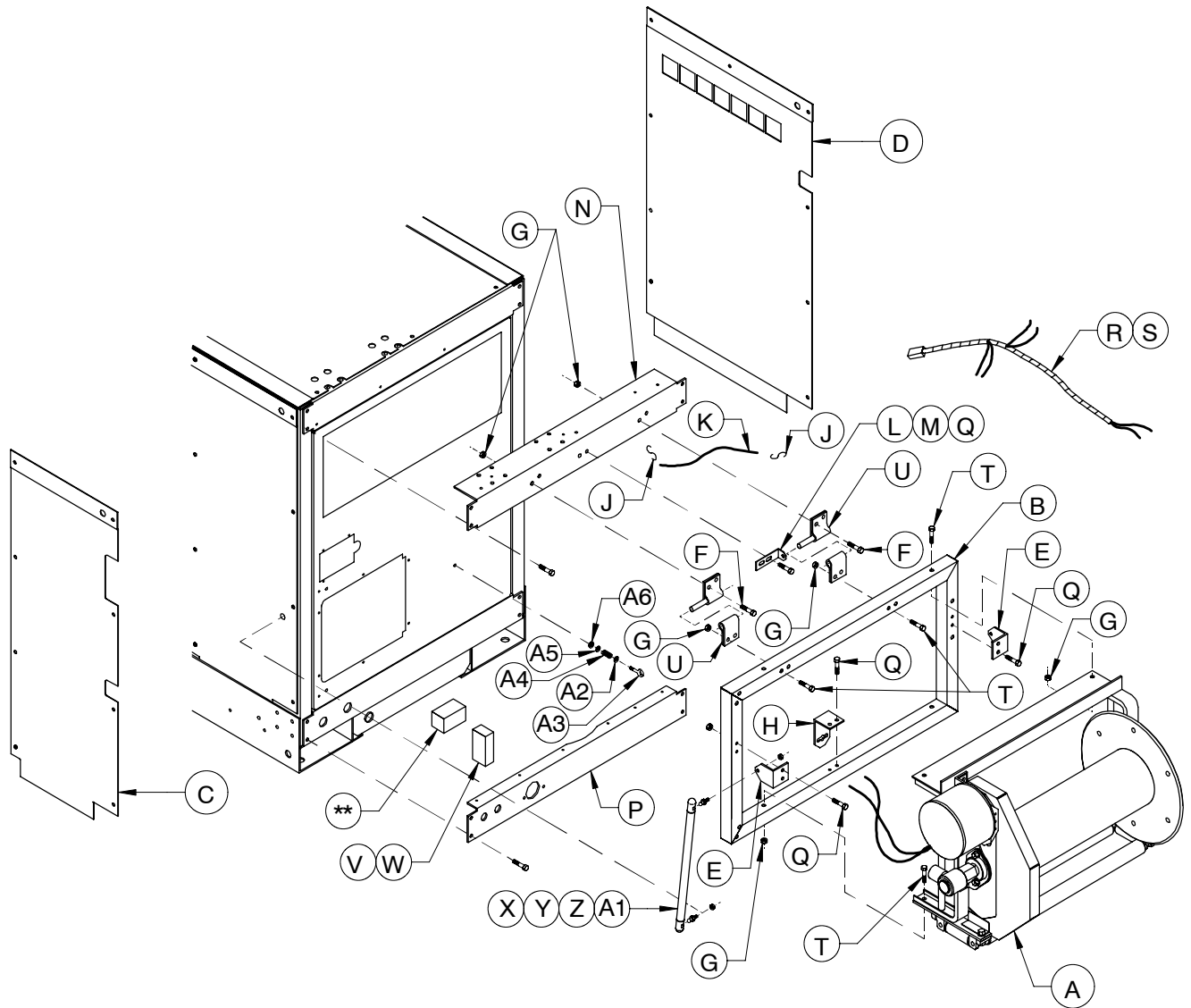

35393065-34		INGERSOLL-RAND COMPANY	
35393628-34		PORTABLE COMPRESSOR DIVISION	
DATE/DWN BY:	DESCRIPTION		
3/24/98 bc	TOP HINGE HOSE REEL ASSY		
MODEL NO.	MANUAL NO.	DATE/REV:	
	OPTION	4/98 A	

ITEM	C.P.N.	QTY	DESCRIPTION
A	36892586	1	HOSE REEL ASSEMBLY
B	36891638	1	FRAME, HOSE REEL
C	36892404	1	PANEL, CAB SIDE
D	36892412	1	PANEL, BED SIDE
E	36896421	2	ANGLE, GAS SPRING
F	36880995	4	SCREW, HEX FLANGE HD M10-1.5 X 30
G	36879195	8	NUT, HEX FLANGE M10-1.5
H	36896355	1	ANGLE, LATCH
J	36861383	2	HOOK, S
K	36786218	1	LANYARD
L	36896348	1	ANGLE, HINGE STOP
M	36896462	1	PLUG, 3/8
N	36896629	1	FRAME, UPPER DOOR
P	36892537	1	FRAME, DOOR LOWER CURB
Q	35279025	8	SCREW, TAPPING M08-1.25 X 20
R	36793008	1	RELIEF, STRAIN
S	36892420	1	HARNESS, H.R. WIRING
T	36766343	8	SCREW, HEX M10-1.5 X 60
U	36891604	2	HINGE, LIFT-OFF
V	35249721	2	SCREW, SELF TAPPING 08-32 X .60
W	36884633	1	BREAKER, CIRCUIT
X	35600279	2	SPRING, GAS
Y	35337328	4	STUD, BALL M08-1.25
Z	95934998	4	WASHER, FLAT
A1	36881886	4	NUT, HEX M08-1.25
A2	36772028	1	WASHER, NYLON
A3	35607829	1	EYEBOLT, 1/4-20 X 2.5
A4	35607837	1	SPRING
A5	95935029	1	WASHER, FLAT
A6	95926298	1	NUT, HEX LOCK 1/4-20

** SUPPLIED WITH HOSE REEL

35393065-35		INGERSOLL-RAND COMPANY	
35393628-35		PORTABLE COMPRESSOR DIVISION	
DATE/DWN BY:	DESCRIPTION		
3/24/98	bc TOP HINGE HOSE REEL ASSY		
MODEL NO.	MANUAL NO.	DATE/REV:	
	OPTION	4/98 A	

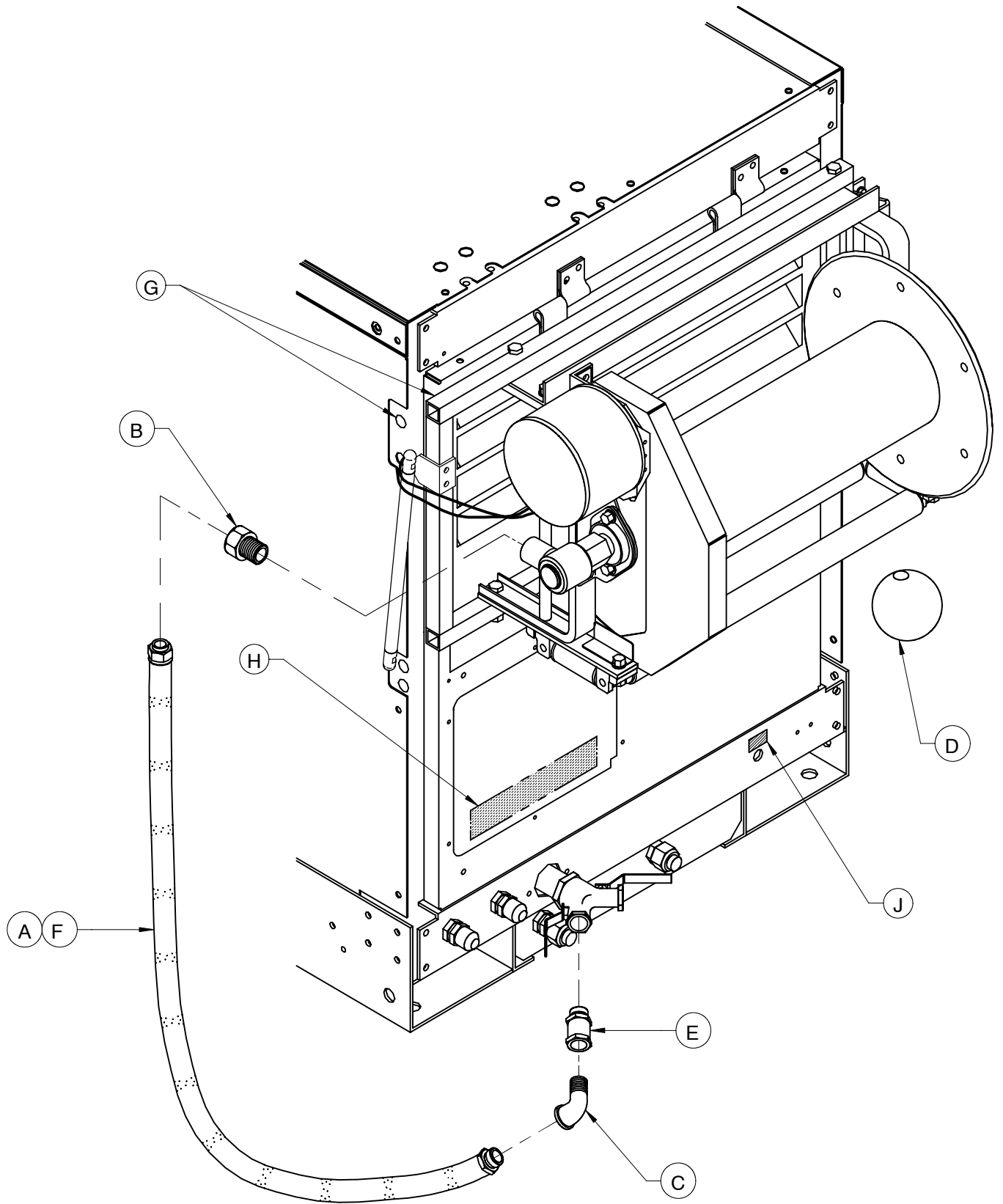

35393065-36		INGERSOLL-RAND COMPANY	
35393628-36		PORTABLE COMPRESSOR DIVISION	
DATE/DWN BY:	DESCRIPTION		
3/24/98 bc	TOP HINGE HOSE REEL ASSY		
MODEL NO.	MANUAL NO.	DATE/REV:	
	OPTION	4/98 A	

ITEM	C.P.N.	QTY	DESCRIPTION
A	35323807	1	HOSE ASSEMBLY
B	95219747	1	ADAPTER, 3/4 NPT X 3/4 JIC
C	35294735	1	ELBOW, 3/4 NPT X 12 JIC
D	35378322	1	STOP, HOSE
E	35364371	1	VALVE, CHECK EXCESS FLOW (P130)
	35364397	1	VALVE, CHECK EXCESS FLOW (P175 - P185)
F	35225077	4	CLAMP, HOSE
G	36896462	16	PLUG, 3/8
H	36532042	1	DECAL, HOSE REEL OPER INST
J	36531945	1	DECAL, HOSE REEL REWIND

35393065-37		INGERSOLL-RAND COMPANY	
35393628-37		PORTABLE COMPRESSOR DIVISION	
DATE/DWN BY:	DESCRIPTION		
3/24/98 bc	TOP HINGE HOSE REEL ASSY		
MODEL NO.	MANUAL NO.	DATE/REV:	
	OPTION	4/98 A	

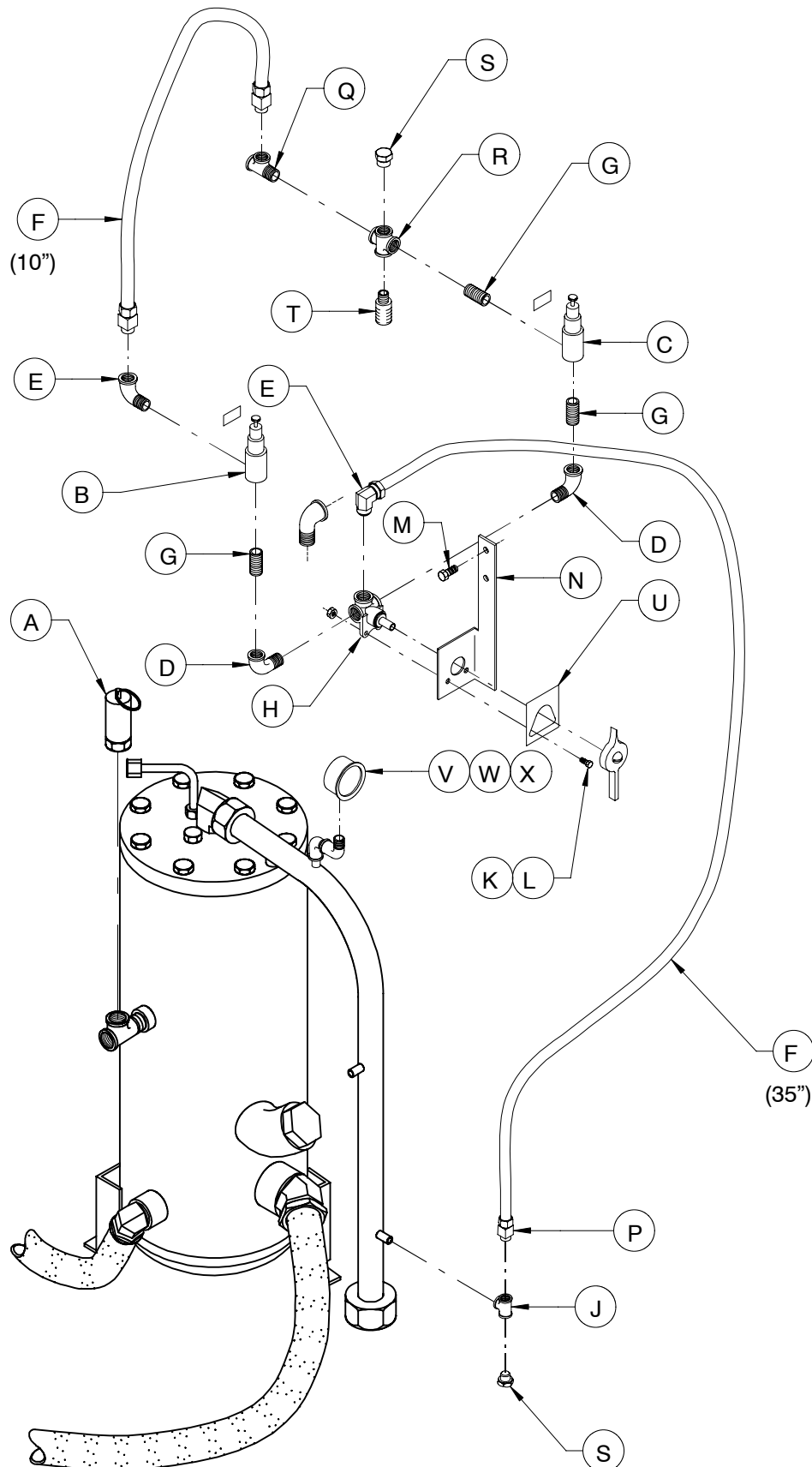

35393065-38		INGERSOLL-RAND COMPANY	
35393628-38		PORTABLE COMPRESSOR DIVISION	
DATE/DWN BY:	DESCRIPTION		
2/4/99	bc DUAL REGULATION OPTION		
MODEL NO.	MANUAL NO.	DATE/REV:	
	OPTION	4/98 A	

ITEM	C.P.N.	QTY	DESCRIPTION
A	36920254	1	VALVE, SAFETY
B	36854149	1	VALVE, 100 PSI PRESSURE REGULATOR
C	36854495	1	VALVE, 150 PSI PRESSURE REGULATOR
D	95944666	2	ELBOW, 90° STREET 1/4 NPT
E	35369354	2	ELBOW, MALE 1/4 NPT X 3/8 TUBE
F	35356484	*	TUBE, 3/8 OD
G	95667341	3	NIPPLE, CLOSED 1/4 NPT X 7/8
H	36864684	1	VALVE, 3-WAY
J	35321272	1	TEE, 1/4 NPT
K	36769024	2	SCREW, HEX M06-1.0 X 20
L	96703806	2	NUT, HEX M06
M	35279025	2	SCREW, TAPPING M08-1.25 X 20
N	36895357	1	BRACKET, DUAL REGULATOR
P	35369347	1	CONNECTOR, MALE 1/4 NPT X 3/8 TUBE
Q	35369503	1	TEE, MALE RUN 1/4 NPT X 3/8 TUBE
R	95954293	1	CROSS, 1/4 NPT
S	95928230	2	PLUG, HEX CTSK 1/4 NPT
T	36766756	1	ORIFICE, MUFFLER .140
U	36530756	1	DECAL, DUAL REGULATION
V	36879906	1	GUAGE, 250# PRESSURE
W	35392323	1	LAMP, BULB 12 V
X	35392331	1	LAMP, SOCKET

35393065-39		INGERSOLL-RAND COMPANY	
35393628-39		PORTABLE COMPRESSOR DIVISION	
DATE/DWN BY:	DESCRIPTION		
2/4/99	bc DUAL REGULATION OPTION		
MODEL NO.	MANUAL NO.	DATE/REV:	
	OPTION	4/98 A	

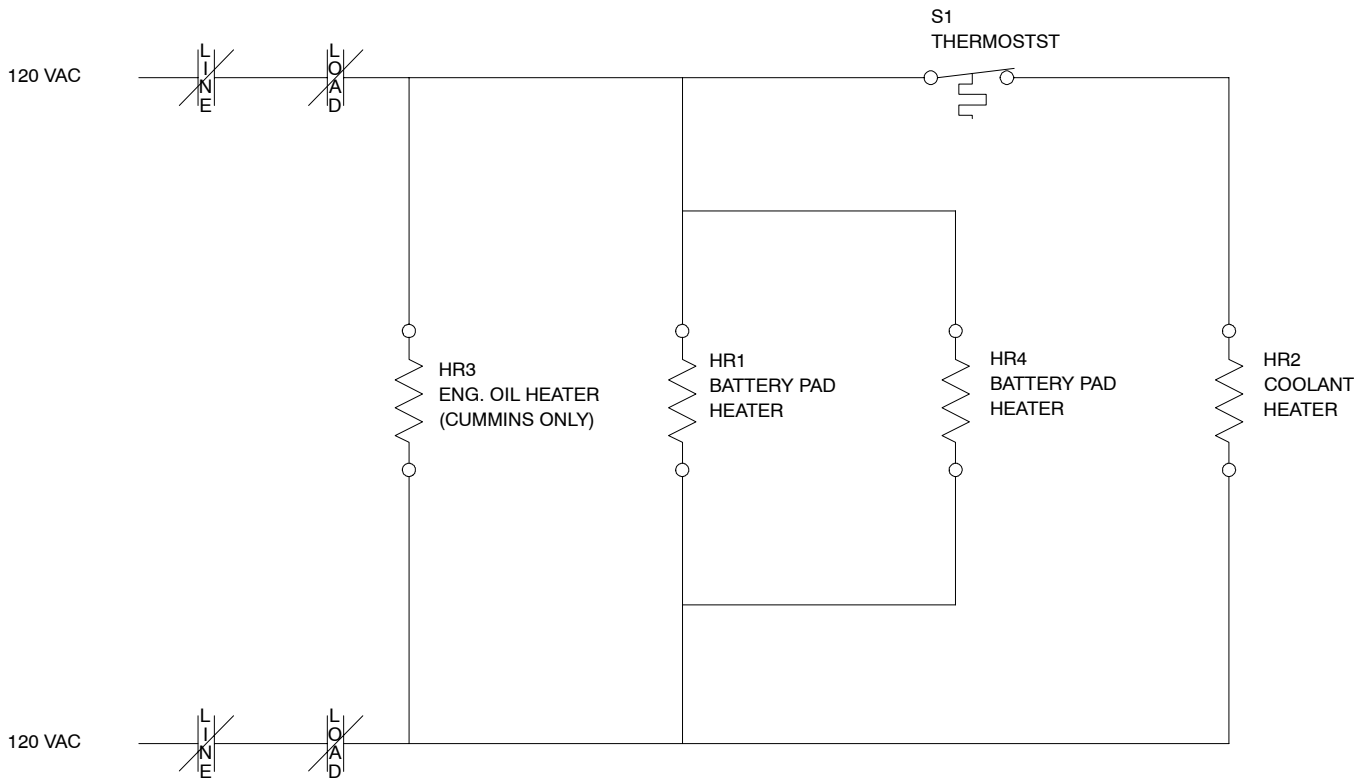

NOTE: REFER TO MODEL FOR LIST OF OPTIONAL HEATERS AVAILABLE

	P100-P160	P100-P160	J DEERE P175-XP185	CUMMINS P250-P375 E25-E50	KUBOTA L5; L6-L8	CUMMINS VHP400-P600
HR1	~	~	36920387	36920387	36920387	36920379
HR2	36843563	35379221	36874659	36898971	36898252	36898971
HR3	~	~	~	~	~	~
HR4	~	~	~	~	~	36920387
S1	~	~	36858751	36858751	~	36858751
W1	~	~	36920361	36920361	36898245	36920361

	CUMMINS HP600-XP825	J DEERE HP600-XP825	CAT XHP600-XHP900	CUMMINS VHP825-XP1050	CAT VHP750-XP1000	CUMMINS HP100-P1600
HR1	36920411	36920411	36920338	36920411	36920411	36920338
HR2	36874642	36874659	36871325	36852614	36871283	36882520
HR3	36874675	~	~	36869691	~	36882512
HR4	36920429	36920429	36920346	36920429	36920429	36920346
S1	36858751	36858751	36858751	36858751	36858751	36858751
W1	36920437	36920403	36871317	36852598	36871275	36920320

35392893-55	35380277-44	35391825-93	35390095-84	INGERSOLL-RAND COMPANY PORTABLE COMPRESSOR DIVISION DATE/DWN BY: 7/6/99 bc DESCRIPTION: 110 VAC HEATER WIRING		
35392901-55	35393396-44	35391713-93	35391093-84			
	35393065-40	35391721-93	35392877-84		OPTION	7/99 A
	35393628-40	35391739-93	35392885-84			
	54437173-93	35392984-93	35393172-84			