



OPERATING & PARTS MANUAL

2.0 H.P.



ATTENTION:
**FOR BEST PERFORMANCE IDLE ENGINE FOR 1-2 MINUTES
BEFORE YOU START DRILLING.**

StrikeMaster Corporation
P.O. Box 567 • 17217 198th Avenue • Big Lake, Minnesota 55309
Phone (763) 263-8999 • Fax (763) 263-8986
www.strikemaster.com

StrikeMaster Ice Augers

Ice Fishing has become one of the fastest growing and most popular winter sports, allowing the ardent angler the opportunity to enjoy his or her favorite outdoor activity.

When you selected a StrikeMaster power ice auger, you selected a product that has gained a reputation as the quality leader since 1946. And, there is no doubt that this year's model is the finest ever produced by StrikeMaster Corporation.

Your new StrikeMaster ice auger has all of the most wanted features in a power ice auger, to assure many years of enjoyable ice fishing. Some of these features such as workmanship, engineering excellence, and dependability have long been standards at StrikeMaster. Your new power ice auger boasts many new features while retaining the best features developed in previous years to enhance your ice fishing experience and add to your satisfaction in selecting StrikeMaster.

We know that you are anxious to go fishing and use your new power ice auger, but, before you go fishing, it is important and to your advantage to spend a few minutes getting acquainted with your new StrikeMaster power ice auger. There is no better way to acquaint yourself with the product than to read the Owners' Manual and Operating Instructions. A few minutes spent studying this manual before your first ice fishing outing will be time well spent.

Record your Model and Serial No.'s immediately after purchase (see bottom of pg. 8). Also, please return the enclosed WARRANTY CARD to validate your limited warranty.



THIS SYMBOL POINTS OUT IMPORTANT SAFETY INSTRUCTIONS WHICH IF NOT FOLLOWED COULD ENDANGER THE PERSONAL SAFETY AND/OR PROPERTY OF YOURSELF AND OTHERS. READ AND FOLLOW ALL INSTRUCTIONS IN THIS MANUAL AND ANY PROVIDED WITH OR ON THE EQUIPMENT ON WHICH THIS ENGINE IS USED BEFORE ATTEMPTING TO OPERATE YOUR STRIKEMASTER POWER ICE AUGER.



TABLE OF CONTENTS

Important Safeguards	2	Service Information	3
Adjustments	7	Starting/Operation	5
Assembly Instructions	2	Stopping Engine	6
Maintenance	6-7	Storage	7
Oil/Fuel Mixing	4-5	Warranty Card	10
Operating Instructions	2		

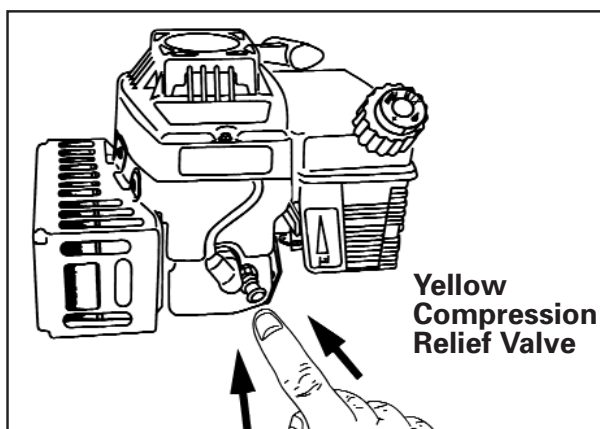

ATTENTION

This engine is equipped with a compression release valve for easier starting. Press the valve in before every start to reduce cylinder pressure. (See Page 4)

IMPORTANT SAFEGUARDS

It is recommended that everyone who uses this product should read the StrikeMaster OPERATING MANUAL and the TECUMSEH engine OPERATOR'S MANUAL before operation.

1. **▲ DO NOT** use this product for any purpose other than cutting ice fishing holes. Ice augers are precision cutting tools built for the ice fisherman, and must be properly maintained and handled with caution during both cutting and transporting. When not in use, always store with blade guard attached.
2. **▲ DO NOT** use attachments other than those available from the manufacturer.
3. **▲ DO NOT** alter this product in any manner; doing so is dangerous and voids all warranties.
4. **▲ DO NOT** allow children or adults weighing under 100 lbs. to operate this equipment.
5. **▲ DO NOT** allow your body, loose clothing, drawstrings, scarves, hats or other materials to come in contact with the Powerhead, Starter Assembly or Auger (Drill) unit at any time.
6. **▲ DO NOT** operate if, upon pulling the starter rope or after drilling holes, the auger (drill) unit rotates or if the rope pulls hard. **DO NOT OPERATE.** Have the unit checked by a qualified mechanic.
7. **▲ DO NOT** allow the engine to run or operate while moving or transporting to another location.
8. **▲ DO NOT** continue to use this product in the event of mechanical or electrical failure.
9. **▲** This product produces considerable cutting force that is felt by the operator. Make sure your feet are firmly planted and that the handles are held firmly while operating this product.
10. **▲** Always check the operation of the throttle system to ensure the carburetor control is completely returning to the idle position when the throttle lever is released.
11. **▲ Check cutting blades and auger shaft screws before and after each use to make sure they are tight.**
12. **▲** During operation, the auger unit could possibly stop. Be prepared at all times to release the throttle lever.
13. **▲ Everyone who uses this product should read this manual and the TECUMSEH operating manual before operating this unit.**
14. **▲** The cutting blades on the ice auger are razor sharp. Use extreme care when handling.
15. **▲** The manufacturer recommends that all augers, Lazer Mag Xpress, Strike-Lite, Lazer 224, Mag 2000 and Electra Lazer 12000 DP be used for ice cutting only.

▲ Assembly ▲

1. Remove the Metric allen wrench that is attached near the top of the auger assembly. DO NOT remove the blade guard during the assembly process.
2. Insert the wrench into the connecting bolt at the top of the auger assembly and remove by turning counter-clockwise.
3. Remove protective plastic cap from drive shaft. Insert the drive shaft of the Powerhead into the plastic collar of the auger assembly.
4. Align the holes in the plastic collar and the Powerhead shaft and insert the bolt. Turning the allen wrench clockwise, tighten the bolt until firm. When tightened firmly, there will still be a slight movement or "wobble" at the connection. This movement is normal, if the fit of the connection were too tight, it would be very difficult to remove the auger assembly.
5. After assembly is complete, you can conveniently store your allen wrench on the underside of the throttle lever.
6. **After the first use of the unit, it is recommended that the collar bolt be checked and torqued firmly.**



▲ Operation ▲

1. **Start engine as explained in the TECUMSEH engine manual. (See page 5-6). For best cutting performance, run engine at idle for one minute before drilling.**
2. Hold the unit in a vertical position with your right hand pushing downward to open throttle, and your left hand firmly holding the opposite handle.
3. This product produces considerable cutting force that is felt by the operator. Make sure your feet are firmly planted and that the handles are held firmly while operating this product.
4. Push the throttle lever downward to increase the engine speed. As the engine speed increases the centrifugal clutch will engage and the auger will begin to rotate.
5. During the operation of cutting, the auger could possibly stop if it comes in contact with a foreign object or if it binds in the hole. Be prepared at all times to release the throttle lever to avoid rotation of the handle assembly.

Operation (Continued)

6. After cutting ice fishing holes the unit should be placed on the ice in a horizontal position with the blade guard attached to protect against personal injury or damage to the auger shaft or blade(s).
(Never store or stand an ice auger upright in a partially drilled ice fishing hole.)



⚠ Stop Engine ⚠

1. After completing the cutting of an ice fishing hole, **STOP** the engine by allowing the engine to return to idle and moving the ignition switch to the **OFF** position. If the engine fails to stop, move the choke lever to the **FULL CHOKE** position to kill the engine. Always check the throttle system to ensure the carburetor throttle lever is returning to the idle position. If the ignition switch should fail, **DO NOT** operate until the ignition switch has been repaired by a qualified mechanic.
2. After engine is stopped, close the fuel cap vent.
3. Attach the blade guard to protect blade(s).
4. The cutting blades on the ice augers are razor sharp. Use extreme care when handling.
5. Use caution when removing or replacing blade guard.
6. Use caution when replacing or honing auger blades.
7. Always keep blade guard on auger except when in use.
8. The use of this auger by children is not recommended.

Customer Service

Continued satisfying performance from your StrikeMaster power ice auger may be assured by applying a minimum amount of preventive maintenance when it is required. The following information is intended to inform you as to where and how you may obtain additional service support.

StrikeMaster Corporation at 763-263-8999 for the service center nearest you. Or visit our website under service centers for a full list of authorized service centers: www.strikemaster.com/service.html

If for any reason you are in doubt, or have any questions regarding the proper operation, and use of this product, or warranty information please feel free to call during regular business hours or write to: (Sorry - No Collect Calls)

StrikeMaster Corporation
P.O. Box 567 • 17217 198th Avenue • Big Lake, Minnesota, USA 55309
Phone: (763) 263-8999 Fax: (763) 263-8986
www.strikemaster.com

For engine adjustments, repairs or warranty service contact your nearest AUTHORIZED TECUMSEH SERVICE OUTLET. It is listed in your telephone book Yellow Pages under "Engines, Gasoline".

If you cannot locate a dealer please call one of the following Central Warehouse distributors closest to you for assistance. Or call Tecumseh Products Company, Grafton, Wisconsin at **800-558-5402** for a dealer nearest you.

Billious Inc.
Porterville, CALIFORNIA
800-245-5468

Central Power Distributors
Anoka, MINNESOTA
763-576-0901

W.J. Connell
Foxboro, MASSACHUSETTS
800-456-5691

Pacific Power Equipment
Denver, COLORADO
800-767-7891

Original Equipment
Billings, MONTANA
800-332-7158

CPT Canada Power
Edmonton, ALBERTA
800-661-7950
Mississauga, ONTARIO
800-861-9559

Frank Edwards Co.
Salt Lake City, UTAH
800-366-4563

Gardner Inc., East
Cranbury, NEW JERSEY
800-336-7808

Pitt Auto Electric
Pittsburgh, PENNSYLVANIA
800-892-7322

Smith Engines
Charlotte, NORTH CAROLINA
800-951-5318

Gardner Inc., West
Columbus, OHIO
800-848-8946

Industrial Engine & Parts
Waukegan, ILLINOIS
800-544-0603

Medart Engines
Edwardville, KANSAS
Fenton, MISSOURI
Tulsa, OKLAHOMA
800-888-7181

Power Equipment Systems
Salem, OREGON
800-782-2700

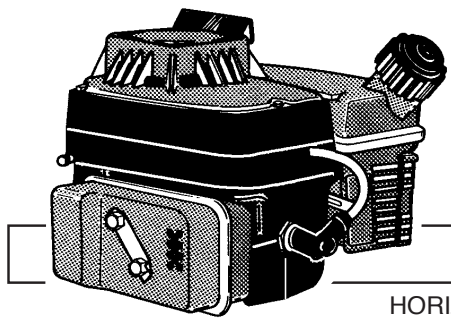

OPERATOR'S MANUAL

and MAINTENANCE INSTRUCTIONS for

TECUMSEH

RESPECT NATURE
The Commitment

MODEL TMO 49XA

HORIZONTAL/VERTICAL CRANKSHAFT • AIR COOLED • TWO-CYCLE ENGINE

! THIS SYMBOL POINTS OUT IMPORTANT SAFETY INSTRUCTIONS WHICH IF NOT FOLLOWED COULD ENDANGER THE PERSONAL SAFETY AND/OR PROPERTY OF YOURSELF AND OTHERS. READ AND FOLLOW ALL INSTRUCTIONS IN THIS MANUAL AND ANY PROVIDED WITH THE EQUIPMENT ON WHICH THIS ENGINE IS USED BEFORE ATTEMPTING TO OPERATE YOUR TECUMSEH ENGINE. **!**

THESE SYMBOLS MAY APPEAR ON THE ENGINE:

 FAST
 SLOW
 STOP
 OFF
 CHOKE
 ON

! California Proposition 65 **WARNING:** The engine exhaust from this product contains chemicals known to the State of California to cause cancer, birth defects or other reproductive harm.

Note: For any information not covered in this manual, please refer to the complete Tecumseh Manual enclosed in the carton along with this manual.

3 MIXING OIL & GASOLINE
THE FUEL/OIL MIX RATIO IS 24:1 WITH THE USE OF A NMMA, TC-WII or TC-W3 CLASSIFIED OIL.

! CAUTION **!**

DO NOT start engine without pushing in yellow compression relief valve FIRST. Failure to do so may result in bruised fingers and accidental equipment movement which could result in minor or moderate injury.

Push yellow compression relief valve in. See Figure 1A

Note: Yellow compression relief valve will "pop" outward once engine starts.

FIGURE 1A
YELLOW COMPRESSION RELIEF VALVE

FUEL MIX CHART		MIXTURE 24:1	
U.S.		S.I.(METRIC)	
Gas	Oil To Be Added	Petrol	Oil To Be Added
1 Gal.	5 oz.	4 Liters	167 ml
2 Gal.	11 oz.	8 Liters	333 ml
5 Gal.	27 oz.	20 Liters	833 ml

NOTE:
Engines which are certified to comply with California and U.S. EPA emission regulations for SORE (Small Off Road Equipment), are certified to operate on regular unleaded gasoline, and include the following emission control systems: Engine Modification (EM), and Three-way Catalyst (TWC) (if so equipped).

OIL & FUEL RECOMMENDATIONS

1 USE CLEAN, HIGH QUALITY 2 CYCLE OIL, NMMA TC-WII, OR TC-W3.
TECUMSEH SPECIALLY FORMULATED OIL IS RECOMMENDED AND AVAILABLE FROM ANY AUTHORIZED TECUMSEH SERVICE OUTLET BY SPECIFYING PART NUMBER 730227. DO NOT USE MULTI-VISCOSITY OIL!

2 A FRESH, CLEAN, UNLEADED REGULAR, UNLEADED PREMIUM, OR REFORMULATED AUTOMOTIVE GASOLINE ONLY. DO NOT USE LEADED GASOLINE.

NOTE: DO NOT USE GASOLINE CONTAINING METHANOL (WOOD ALCOHOL). Fuel containing up to 10% ethanol (Gasohol) or up to 15% MTBE (Methyl Tertiary Butyl Ether) may be used but requires special care when engine is not used for extended periods. See "STORAGE" instructions on Page 7.

NOTE: See decal located on engine for Model and Serial Number

STARTER HANDLE FUEL TANK
FUEL FILL CAP
MODEL AND D.O.M NUMBER DECAL
RECOIL STARTER
MUFFLER
SPARK PLUG WIRE AIR CLEANER
OPERATING INSTRUCTIONS
COOLING FINS SPARK PLUG YELLOW COMPRESSION RELIEF VALVE
MODEL & SERIAL NUMBERS

Figure 1

DO NOT MIX DIRECTLY IN ENGINE FUEL TANK.

1. Fill approved, clean container one quarter full with recommended gasoline.
2. Add recommended oil to gasoline per FUEL MIX CHART.
3. Screw cap on container and shake vigorously. Then unscrew cap and fill container with gasoline as shown in FUEL MIX CHART. Once mixed, oil and gasoline will not separate.

! NEVER MIX OR STORE GASOLINE/OIL MIXTURE INDOORS OR IN ENCLOSED, POORLY VENTILATED AREAS, WHERE FUEL FUMES MAY REACH AN OPEN FLAME, SPARK OR PILOT LIGHT AS ON A FURNACE, WATER HEATER, CLOTHES DRYER OR OTHER GAS APPLIANCE.

BEFORE STARTING

1 READ ALL INSTRUCTIONS PROVIDED WITH THE EQUIPMENT ON WHICH THIS ENGINE IS USED. AFTER READING THE OPERATING MANUAL, PLEASE TAKE TIME TO VIEW THE SAFETY/INSTRUCTIONAL VIDEO ON THE DVD INCLUDED WITH YOUR AUGER

2 FILL FUEL TANK:

- Clean area around fuel fill cap, remove cap.
- Add FUEL MIX specified in the preceding "OIL & FUEL RECOMMENDATIONS" item ③. Use a funnel to help avoid spillage.

Never use "stale" gasoline left over from last season or stored for long periods.

! C. Install fuel fill cap and wipe up any spilled FUEL MIX.

! NEVER FILL FUEL TANK INDOORS. NEVER FILL FUEL TANK WHEN ENGINE IS RUNNING OR HOT. DO NOT SMOKE WHEN FILLING FUEL TANK.

! NEVER FILL FUEL TANK COMPLETELY. FILL TANK TO 1/2" BELOW BOTTOM OF FILLER NECK TO PROVIDE SPACE FOR FUEL EXPANSION.

! WIPE ANY FUEL SPILLAGE FROM ENGINE AND EQUIPMENT BEFORE STARTING ENGINE.

STOP / START SWITCH

- The Stop Switch is located on the throttle lever. Set the Stop Switch to the "on" position before starting. To Stop turn switch to the off position.

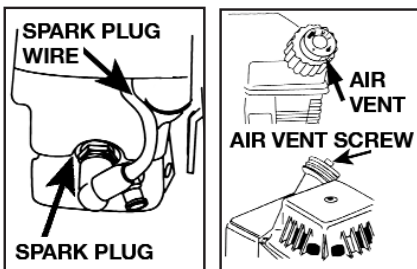
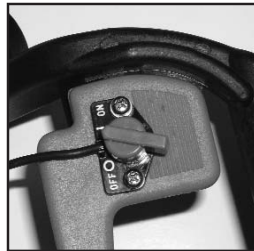

Figure 2

! CAUTION **!**

DO NOT start engine without pushing in yellow compression relief valve FIRST. Failure to do so may result in bruised fingers and accidental equipment movement which could result in minor or moderate injury.

Push yellow compression relief valve in. See Figure 3A

Note: Yellow compression relief valve will "pop" outward once engine starts.

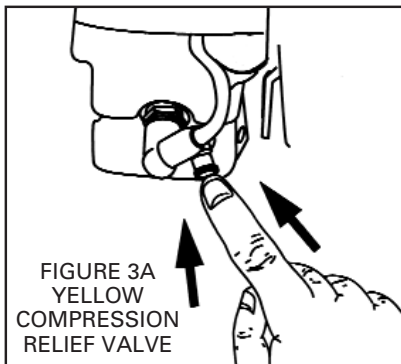

3 CHECK THE FOLLOWING:

- !** BE SURE EQUIPMENT IS IN NEUTRAL GEAR WITH CLUTCHES, BELTS, CHAINS AND SAFETY SWITCHES DISENGAGED. (FOLLOW EQUIPMENT MANUFACTURER'S INSTRUCTIONS). THIS SHOULD PLACE ANY SAFETY SWITCHES IN SAFE STARTING POSITION.
- Be sure spark plug wire is attached to spark plug (see figure 2).
- Be sure any ignition switch on engine or equipment is in "ON", "RUN" or "START" position.
- Be sure air vent on fuel fill cap is free of debris and air vent screw (if so equipped - see Figure 2) is open.

STARTING

! NEVER RUN ENGINE INDOORS OR IN ENCLOSED, POORLY VENTILATED AREAS. ENGINE EXHAUST CONTAINS CARBON MONOXIDE, AN ODORLESS AND DEADLY GAS.

! KEEP HANDS, FEET, HAIR AND LOOSE CLOTHING AWAY FROM ANY MOVING PARTS ON ENGINE AND EQUIPMENT.

! WARNING - TEMPERATURE OF MUFFLER AND NEAR BY AREAS MAY EXCEED 150°F (65°C). AVOID THESE AREAS.

1 ENGINE

- Push yellow compression relief valve in toward engine.
- Move choke lever (see figure 3) to "FULL CHOKE" (see equipment manufacturer's instructions).

NOTE: IF RESTARTING A WARM ENGINE AFTER A SHORT SHUTDOWN, MOVE CHOKE LEVER TO "NO CHOKE".

- Grasp starter handle (see Figure 4) and pull rope out, slowly, until it pulls harder. Let rope rewind slowly. Then pull rope with a rapid **short** arm stroke. Let rope return to starter slowly.
- Repeat instruction A & C until engine fires. When engine starts move choke lever to "1/2 CHOKE" until engine runs smoothly and then to "NO CHOKE".

If engine falters, move choke lever to "1/2 CHOKE" until engine runs smoothly and then to "NO CHOKE".

NOTE: If engine fires, but does not continue to run, move choke lever to "NO CHOKE" and repeat instruction A & C until engine starts.

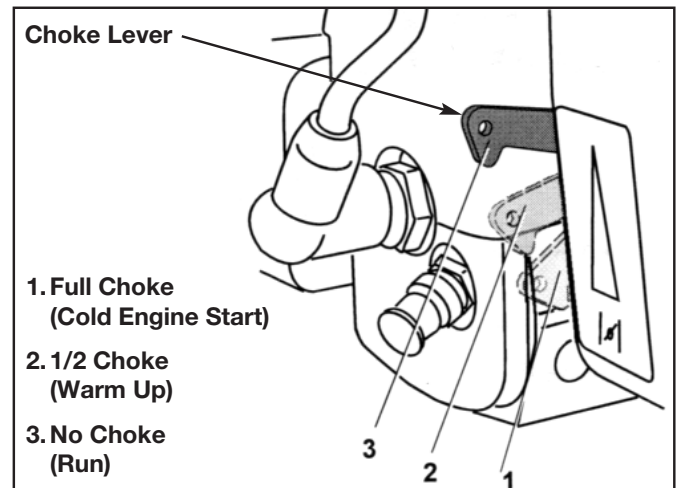

Figure 3

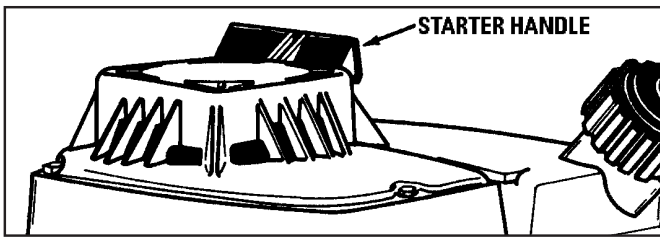

Figure 4

STOPPING

① Move remote control on equipment or any ignition stop switch in engine to "STOP" or "OFF" (see equipment manufacturer's instructions). See Figure 2.

② AFTER ENGINE IS STOPPED:

A. Close air vent screw on fuel fill cap (if so equipped, see Figure 2).

⚠ B. **DISCONNECT SPARK PLUG WIRE FROM SPARK PLUG AND KEEP IT AWAY FROM SPARK PLUG.**

⚠ C. **TURN IGNITION SWITCH KEY (IF SO EQUIPPED) TO "OFF" POSITION. THIS WILL REDUCE THE POSSIBILITY OF UNAUTHORIZED STARTING OF ENGINE WHILE EQUIPMENT IS NOT IN USE.**

⚠ **NEVER STORE ENGINE WITH FUEL IN TANK INDOORS OR IN ENCLOSED POORLY VENTILATED AREAS, WHERE FUEL FUMES MAY REACH AN OPEN FLAME, SPARK OR PILOT LIGHT AS ON A FURNACE, WATER HEATER, CLOTHES DRYER OR OTHER GAS APPLIANCE.**

MAINTENANCE

⚠ **WARNING — TEMPERATURE OF MUFFLER AND NEAR BY AREAS MAY EXCEED 150°F (65°C). AVOID THESE AREAS.**

① AIR CLEANER:

IMPORTANT: NEVER RUN ENGINE WITHOUT COMPLETE AIR CLEANER INSTALLED ON ENGINE.

A. **TO REMOVE AND INSTALL FILTER(S):** (see Figure 5)

1. Loosen two Screws.
2. Remove cover.
3. Remove optional pre-filter (if so equipped).
4. Remove foam filter.
5. Inspect pre-filter (if so equipped) or foam filter for discoloration or dirt accumulation. If either is present, service per "TO SERVICE FILTER(S)" instructions.
6. Clean inside of cover and body thoroughly.

B. **TO SERVICE FILTER(S):** (see Figure 5)

1. FOAM FILTER:

Clean and re-oil every three (3) months or every 25 operating hours. Clean and re-oil daily if used in extremely dusty conditions.

- a. Wash in water and detergent solution and squeeze (don't twist) until all dirt is removed.
- b. Rinse thoroughly in clear water.
- c. Wrap in a clean cloth and squeeze (don't twist) until completely dry.
- d. Saturate with engine oil and squeeze (don't twist) to distribute oil and remove excess oil.

C. **REASSEMBLE AIR CLEANER AS SHOWN IN FIGURE 5.**

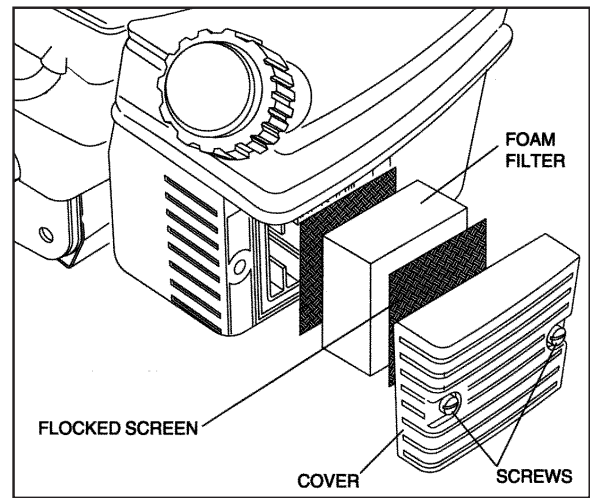

Figure 5

② SPARK PLUG (see Figure 6)

This spark ignition system meets all requirements of the Canadian Interference-Causing Equipment Regulations. This engine complies with all current Australian and New Zealand limitations regarding electromagnetic interference. This engine complies with the European standard for safety of garden equipment and powered lawnmowers EN 836, Revision March, 1997, and applicable sections of the EU Machinery Safety Directives.

Check spark plug yearly or every 50 operating hours.

- A. Clean area around spark plug.
- B. Remove and inspect spark plug.
- C. Replace spark plug if electrodes are pitted, burned or porcelain is cracked. Replace as follows:

For replacement use Champion CJ6Y or equivalent.

NOTE: A resistor spark plug must be used for replacement.

- D. Check electrode gap with wire feeler gage and set gap at .030 if necessary.
- E. Install spark plug, tighten securely.

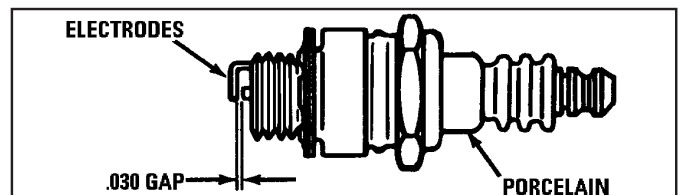

Figure 6

③ COOLING SYSTEM (see Figure 7)

IMPORTANT: Frequently remove grass clippings, dirt and debris from cooling fins, air intake screen and levers and linkage. This will help insure adequate cooling and correct engine speed.

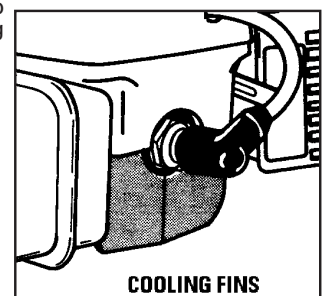

Figure 7

MAINTENANCE (continued)

4 MUFFLER AND CYLINDER EXHAUST PORTS:
The muffler and cylinder exhaust ports require cleaning after every 75 - 100 hours of operation. For this maintenance procedure we recommend that you take your engine to your Authorized Tecumseh Dealer.

5 CHECK ENGINE AND EQUIPMENT OFTEN FOR LOOSE NUTS, BOLTS AND ATTACHMENTS AND KEEP THESE ITEMS TIGHTENED.

6 GAS CAPS
During normal use, the gas caps of some power augers will develop a leaking gasket. This is caused by either over tightening the ventilation screw or just repeated use and normal wear. If you experience problems please follow these instructions.

1. Remove the old gas cap from the gas tank.
2. Replace old gas cap with replacement gas cap (PN 410285) available from StrikeMaster.



ADJUSTMENTS

DO NOT MAKE UNNECESSARY ADJUSTMENTS. FACTORY SETTINGS ARE SATISFACTORY FOR MOST CONDITIONS.

1 CARBURETOR:
If you think your carburetor needs adjusting, see your nearest AUTHORIZED TECUMSEH SERVICE OUTLET.

2 ENGINE SPEED:
NEVER TAMPER WITH ENGINE GOVERNOR WHICH IS FACTORY SET FOR PROPER ENGINE SPEED. OVER SPEEDING ENGINE ABOVE FACTORY HIGH SPEED SETTING CAN BE DANGEROUS. CHANGING OF ENGINE GOVERNOR SPEED WILL VOID ENGINE WARRANTY.

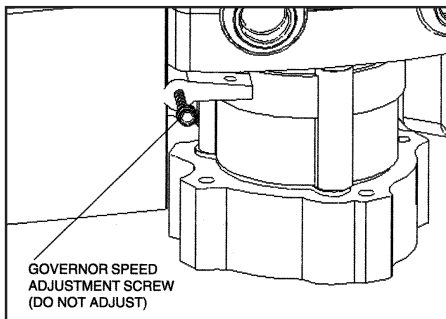

Figure 8

3 REMOTE CHOKE:
See equipment manufacturer's instructions.

STORAGE

! NEVER STORE ENGINE WITH FUEL IN TANK INDOORS OR IN ENCLOSED, POORLY VENTILATED AREAS, WHERE FUEL FUMES MAY REACH AN OPEN FLAME, SPARK OR PILOT LIGHT AS ON A FURNACE, WATER HEATER, CLOTHES DRYER OR OTHER GAS APPLIANCE.

IF ENGINE IS TO BE UNUSED FOR 30 DAYS OR MORE, PREPARE AS FOLLOWS:

1 DRAIN FUEL SYSTEM:

A. Remove all gasoline from carburetor and fuel tank to prevent gum deposits from forming on these parts and causing possible malfunction of engine.

! DRAIN FUEL INTO APPROVED CONTAINER OUTDOORS, AWAY FROM OPEN FLAME. BE SURE ENGINE IS COOL. DO NOT SMOKE.

B. Run engine until fuel tank is empty and engine stops due to lack of fuel.

NOTE: If "Gasohol" has been used, complete above instructions and then put 1/2 pint of gasoline properly mixed with oil per FUEL MIX CHART on Page 1 into fuel tank and repeat above instructions.

NOTE: Tecumseh Gasoline Stabilizer is an acceptable alternative in minimizing the formation of fuel gum deposits during storage. Add stabilizer to gasoline in fuel tank or storage container. Always follow mix ration found on stabilizer container. Run engine at least 10 minutes after adding stabilizer to allow it to reach carburetor.

2 CYLINDER BORE:

A. Pull starter handle slowly until resistance is felt due to compression pressure, then stop.

B. Release starter tension slowly to prevent engine from reversing due to compression pressure. The position will close both the intake and exhaust ports to prevent corrosion of the piston and cylinder bore.

3 CLEAN ENGINE:

Remove any clippings, dirt, or chaff from exterior of engine.

For engine adjustments and/or repairs not covered in this "OWNER'S MANUAL" see "WARRANTY & REPAIR" on Page 8.

WARRANTY AND REPAIR



For engine adjustments, repairs, or warranty service not covered in this manual, contact your nearest AUTHORIZED TECUMSEH SERVICE OUTLET. It is listed in your telephone book yellow pages under "Engine, Gasoline".

Tecumseh manufactures are responsible only for the engine used on this power equipment. If repair or service is needed for unit, other than engine, contact service source as recommended by equipment manufacturer.

Warranty requirements for engines sold outside of the USA may vary from country to country. For warranty details for your specific country, contact your national Tecumseh Service Distributor. If help is needed in locating our national service distributor, you may contact Tecumseh c/o International Service Coordinator, Engine & Transmission Group Service Division, 900 North Street, Grafton, Wisconsin USA 53024-1499. Telephone in USA 262-377-2700.

LIMITED WARRANTY FOR NEW TECUMSEH ENGINES AND ELECTRONIC IGNITION MODULES

For the time period shown below from the date of purchase, Tecumseh Products Company will, at its option as the exclusive remedy, either repair or replace for the original purchaser, free of charge, any part of any new Tecumseh engine which is found, upon examination by any Tecumseh Authorized Service Outlet or by Tecumseh's factory in Grafton, Wisconsin, to be **DEFECTIVE IN MATERIAL AND/OR WORKMANSHIP**, except as provided below. This Limited Warranty **DOES NOT COVER** (i) any Tecumseh engine or part(s) thereof used to power any vehicle in competitive racing and/or used on any commercial or rental track, or (ii) defects or damage caused by alterations or modifications of new Tecumseh engines or parts or by normal wear, accidents, improper maintenance, improper use or abuse of the product, or failure to follow the instructions contained in an Instruction Manual for the operation of the new Tecumseh engine or part. The cost of normal maintenance or replacement of service items which are not defective shall be paid for by the original purchaser. At the time warranty service is requested evidence must be presented of the date of purchase by the original purchaser. Any charge for making service calls and/or for transporting any engine or part(s) thereof to and from the place where the inspection and/or warranty work is performed is payable solely by the purchaser. The purchaser is responsible for any damage or loss incurred in connection with the transportation of any engine or part(s) thereof submitted for inspection and/or warranty work. **WARRANTY SERVICE CAN ONLY BE PERFORMED BY A TECUMSEH AUTHORIZED SERVICE OUTLET OR BY TECUMSEH AT ITS FACTORY IN GRAFTON, WISCONSIN.** Warranty service can be arranged by contacting either a Tecumseh Authorized Service Outlet (any Tecumseh registered Service Dealer, Tecumseh Master Service Dealer, Tecumseh Authorized Service Distributor, or Tecumseh Central Warehouse Distributor) or by contacting Tecumseh c/o Service Manager, Engine and Transmission Group Service Division, 900 North Street, Grafton, Wisconsin 53024-1499.

ENGINE WARRANTY PERIOD				
Warranty Category†	"CONSUMER USE"+		"COMMERCIAL USE"++	
	Within U.S.A. and Canada	Outside U.S.A. and Canada	Within U.S.A. and Canada	Outside U.S.A. and Canada
(A)	90 day	90 day ⁽¹⁾	No Warranty	No Warranty
(B)	1 Year	1 Year ⁽¹⁾	1 Year	1 Year
(C)	2 Years	1 Year ⁽¹⁾	1 Year	1 Year
(D)	2 Years	2 Years ⁽²⁾	1 Year	1 Year
(E)	2 Years	2 Years	1 Year	1 Year
(H)	2 'n 10 ⁽³⁾	2 'n 10 ⁽³⁾	1 Year	1 Year
(K)	2 'n 10 ⁽³⁾	2 'n 10 ⁽³⁾	2 'n 10 ⁽³⁾	1 Year
(M) ⁽⁷⁾	3 Years	3 Years	1 Year	1 Year

- (1) 2 years for Member States of the European Union. Consumers may have additional legal rights not affected by the terms of this warranty pursuant to EU Directive 1999/44/EC and the national legislation of certain Member States of the European Union.
- (2) 1 year for Australian/New Zealand for rotary mower engines.
- (3) 2 years on engine and 10 years (the first 5 years covering parts and labor only; the second 5 years covering parts only) on electronic ignition.
- (4) For purposes of this warranty policy, "consumer use" shall mean consumer's personal, residential, household use by the original retail purchaser.
- (5) For purposes of this warranty policy, "commercial use" shall mean all other uses, including use for commercial, income producing, or rental purposes.
- (6) The engine warranty category of your engine can be determined by review of the engine model number on the "Important Engine Information" decal. One letter in the engine model number will be surrounded by parenthesis (A), (B), (C), (D), (E), (H) (K) or (M) and that letter is your engine warranty category designation.
- (7) Qualification for three (3) year consumer use warranty under engine warranty category (M) may be determined by notation of an (M) designation on the "Important Engine Information" decal located on the engine housing or an addendum decal affixed adjacent thereto.

THIS EXPRESS WARRANTY IS SUPPLEMENTED BY THE TECUMSEH CALIFORNIA EMISSION CONTROL WARRANTY STATEMENT, if any.

THIS EXPRESS WARRANTY IS IN LIEU OF ALL OTHER EXPRESS WARRANTIES. Neither Tecumseh nor any of its affiliates makes any warranties, representations, or promises, written or oral, as to the quality of the engine or any of its parts, other than as set forth herein. **ANY IMPLIED WARRANTY OF MARKETABILITY, MERCHANTABILITY, OR FITNESS FOR A PARTICULAR PURPOSE, TO THE EXTENT THAT EITHER MAY APPLY TO ANY TECUMSEH ENGINE OR PART(S) THEREOF, SHALL BE LIMITED IN DURATION TO THE PERIODS OF THE EXPRESS WARRANTIES SHOWN IN THE WARRANTY PERIOD CHART ABOVE AND TO THE EXTENT PERMITTED BY LAW ANY AND ALL IMPLIED WARRANTIES ARE EXCLUDED. IN NO EVENT WILL TECUMSEH BE LIABLE FOR ANY INDIRECT, INCIDENTAL, CONSEQUENTIAL OR SPECIAL DAMAGES AND/OR EXPENSES, INCLUDING, BUT NOT LIMITED TO, ANY LOSS OF TIME, INCONVENIENCE, LOSS OF UNIT USE OR ANY COST OR EXPENSE OF SUBSTITUTE UNITS DURING PERIODS OF MALFUNCTION OR NON-USE.**

Some states do not allow limitations on how long an implied warranty lasts or the exclusion or limitation of incidental or consequential damages, so the above limitation(s) or exclusion(s) may not apply to you. This Limited Warranty gives you specific legal rights and you may also have other legal rights which vary from state-to-state.

Tecumseh neither assumes nor authorizes any other person, natural or corporate, to assume for Tecumseh any other obligations or liabilities in connection with or with respect to any Tecumseh product or parts. The seller or dealer of a Tecumseh Product or part has no authority, whatsoever, to make any representations or promises on behalf of Tecumseh or to modify the terms or limitations of Tecumseh's warranty in any way.

FILL IN:

ENGINE
MODEL

SPEC.
NUMBER

WARRANTY
PERIOD

SERIAL
NUMBER

EXAMPLE:

TC200
ENGINE
MODEL

2100D
SPEC.
NUMBER

(B)
WARRANTY
PERIOD

5213G
SERIAL
NUMBER



TECUMSEH PRODUCTS COMPANY

Engine & Transmission Service Group Service Division • 900 North Street • Grafton, WI, USA • 53024-1499

181-1274-14

CALIFORNIA & USA EPA EMISSION CONTROL WARRANTY STATEMENT

YOUR WARRANTY RIGHTS AND OBLIGATIONS

The U. S. Environmental Protection Agency ("EPA"), the California Air Resources Board ("CARB") and Tecumseh Products Co. are pleased to explain the Federal and California Emission Control Systems Warranty on your new small off-road engine. In California, new 1995 and later small off-road engines must be designed, built and equipped to meet the State's stringent anti-smog standards. In other states, new 1997 and later model year engines must be designed, built and equipped, at the time of sale, to meet the U.S. EPA regulations for small non-road engines. Tecumseh Products Co. will warrant the emission control system on your small off-road engine for the periods of time listed below, provided there has been no abuse, neglect, unapproved modification, or improper maintenance of your small off-road engine.

Your emission control system may include parts such as the carburetor, ignition system and exhaust system. Also included may be the compression release system and other emission related assemblies.

Where a warrantable condition exists, Tecumseh Products Co. will repair your small off-road engine at no cost to you for diagnosis, parts and labor.

MANUFACTURER'S EMISSION CONTROL SYSTEM WARRANTY COVERAGE:

Emission control systems on 1995 and later model year California small off-road engines are warranted for two years as hereinafter noted. In other states, 1997 and later model year engines are also warranted for two years. If, during such warranty period, any emission-related part on your engine is defective in materials or workmanship, the part will be repaired or replaced by Tecumseh Products Co.

OWNER'S WARRANTY RESPONSIBILITIES:

As the small off-road engine owner, you are responsible for the performance of the required maintenance listed in your Owner's Manual, but Tecumseh Products Co. will not deny warranty solely due to the lack of receipts or for your failure to provide written evidence of the performance of all scheduled maintenance. As the small off-road engine owner, you should, however, be aware that Tecumseh Products Co. may deny you warranty coverage if your small off-road engine or a part thereof has failed due to abuse, neglect, improper maintenance or unapproved modifications.

You are responsible for presenting your small off-road engine to a Tecumseh Authorized Service Outlet (any Tecumseh Registered Service Dealer, Tecumseh Authorized Service Distributor or Tecumseh Central Warehouse Distributor) as soon as a problem exists. The warranty repairs should be completed in a reasonable amount of time, not to exceed 30 days.

Warranty service can be arranged by contacting either a Authorized Tecumseh Servicing Dealer or by contacting Tecumseh Products Co., c/o Service Manager, Engine and Transmission Group Service Division, 900 North Street, Grafton, WI 53024-1499. Telephone 1-262-377-2700 [or in USA/Canada call 1-800-558-5402] or see your local telephone yellow pages under "Engines, Gasoline" for the name, address and telephone number of a Authorized Tecumseh Servicing Dealer near you.

IMPORTANT NOTE:

This warranty statement explains your rights and obligations under the Emission Control System Warranty ("ECS Warranty") which is provided to you by Tecumseh Products Co. pursuant to California law. Tecumseh Products Co. also provides to original purchasers of new Tecumseh Products Co. engines. The Tecumseh Products Co. Limited Warranties for New Tecumseh Engine and Electronic Ignition Modules ("Tecumseh Products Co. Warranty") which is enclosed with all new Tecumseh Products Co. engines on a separate sheet. The ECS Warranty applies only to the emission control system of your new engine. To the extent that there is any conflict in terms between the ECS Warranty and the Tecumseh Products Co. Warranty, the ECS Warranty shall apply except in any circumstances in which the Tecumseh Products Co. Warranty may provide a longer warranty period. Both the ECS Warranty and the Tecumseh Products Co. Warranty describe important rights and obligations with respect to your new engine.

Warranty service can only be performed by a Tecumseh Products Co. Authorized Servicing Dealer. At the time of requesting warranty service, evidence must be presented of the date of sale to the original purchaser. The purchaser shall pay any charges for making service calls and/or for transporting the products to and from the place where the inspection and/or warranty work is performed. The purchaser shall be responsible for any damage or loss incurred in connection with the transportation of any engine or any part(s) thereof submitted for inspection and/or warranty work.

If you have any questions regarding your warranty rights and responsibilities, you should contact Tecumseh Products Co. at 1-262-377-2700 or in USA/Canada call 1-800-558-5402.

EMISSION CONTROL SYSTEM WARRANTY

Emission Control System Warranty ("ECS Warranty") for 1995 and later model year California small off-road engines (for other states, 1997 and later model year engines):

(a.) **APPLICABILITY:** This warranty shall apply to 1995 and later model year California small off-road engines (for other states, 1997 and later model year engines). The ECS Warranty Period shall begin on the date the new engine or equipment is delivered to its original, end-use purchaser, and shall continue for 24 consecutive months thereafter.

(b.) **GENERAL EMISSIONS WARRANTY COVERAGE: Tecumseh Products Co. warrants to the original, end-use purchaser of the new engine or equipment and to each subsequent purchaser that each of its small off-road engines is:**

(1) Designed, built and equipped so as to conform with all applicable regulations adopted by the Air Resources Board pursuant to its authority in Chapters 1 and 2, Part 5, Division 26 of the Health and Safety Code, and

(1) Free from defects in materials and workmanship which, at any time during the ECS Warranty Period, will cause a warranted emissions-related part to fail to be identical in all material respects to the part as described in the engine manufacturer's application for certification.

(c.) The ECS Warranty only pertains to emissions-related parts on your engine, as follows:

(1) Any warranted, emissions-related parts which are not scheduled for replacement as required maintenance in the Owner's Manual shall be warranted for the ECS Warranty Period. If any such part fails during the ECS Warranty Period, it shall be repaired or replaced by Tecumseh Products Co. according to Subsection 4 below. Any such part repaired or replaced under the ECS Warranty shall be warranted for any remainder of the ECS Warranty Period.

(2) Any warranted, emissions-related part which is scheduled only for regular inspection as specified in the Owner's Manual shall be warranted for the ECS Warranty Period. A statement in such written instructions to the effect of "repair or replace as necessary", shall not reduce the ECS Warranty Period. Any such part repaired or replaced under the ECS Warranty shall be warranted for the remainder of the ECS Warranty Period.

(3) Any warranted, emissions-related part which is scheduled for replacement as required maintenance in the Owner's Manual, shall be warranted for the period of time prior to the first scheduled replacement point for that part. If the part fails prior to the first scheduled replacement, the part shall be repaired or replaced by Tecumseh Products Co. according to Subsection 4 below. Any such emissions-related part repaired or replaced under the ECS Warranty, shall be warranted for the remainder of the ECS Warranty Period prior to the first scheduled replacement point for such emissions-related part.

(4) Repair or replacement of any warranted, emissions related part under this ECS Warranty shall be performed at no charge to the owner at a Tecumseh Authorized Service Outlet.

(5) The owner shall not be charged for diagnostic labor which leads to the determination that a part covered by the ECS Warranty is in fact defective, provided that such diagnostic work is performed at a Tecumseh Authorized Service Outlet.

(6) Tecumseh Products Co. shall be liable for damages to other original engine components or approved modifications proximately caused by a failure under warranty of an emission-related part covered by the ECS Warranty.

(7) Throughout the ECS Warranty Period, Tecumseh Products Co. shall maintain a supply of warranted emission-related parts sufficient to meet the expected demand for such emission-related parts.

(8) Any Tecumseh Products Co. authorized and approved emission-related replacement part may be used in the performance of any ECS Warranty maintenance or repair and will be provided without charge to the owner. Such use shall not reduce Tecumseh Products Co. ECS Warranty obligations.

(9) Unapproved add-on or modified parts may not be used to modify or repair a Tecumseh Products Co. engine. Such use voids this ECS Warranty and shall be sufficient grounds for disallowing an ECS Warranty claim. Tecumseh Products Co. shall not be liable hereunder for failures of any warranted parts of a Tecumseh Products Co. engine caused by the use of such an unapproved add-on or modified part.

Emission related parts include the following:

- | | |
|---|--|
| 1) Carburetor assembly and it's internal components | 4) Catalytic muffler (if so equipped) |
| a) Fuel Filter | a) Muffler gasket (if so equipped) |
| b) Carburetor gaskets | b) Exhaust manifold (if so equipped) |
| c) Intake pipe | |
| 2) Air cleaner assembly | 5) Crankcase breather assembly and it's components |
| a) Air filter element | a) Breather connection tube |
| 3) Ignition system including: | |
| a) Spark plug | |
| b) Ignition module | |
| c) Flywheel assembly | |

StrikeMaster Ice Augers

LIMITED WARRANTY

StrikeMaster Corporation, 17217 198th Avenue, Big Lake, Minnesota 55309 provides the following LIMITED WARRANTY on its products to the purchaser of these products and to any person to whom such products are transferred during the duration of this warranty.

The warrantor's obligation shall be limited to repairing or replacing at the above address, any part or parts which shall within a One Year period hereinafter specified to be returned to them with transportation prepaid (customer is responsible for shipping charges to StrikeMaster) and which upon examination by **StrikeMaster Corporation** shows to have been defective. This warranty shall NOT APPLY IF:

- A. The product has been altered, repaired or modified outside the warrantor's place of business in any way that would adversely affect its operation.
- B. The product has been subjected to misuse or damage while in the possession of the purchaser or was operated or used other than in accordance with the manufacturer's operating instructions.
- C. The product failure is attributed to damage which is the sole responsibility of the user.

The One Year limited warranty period shall commence with the date the product is sold to the purchaser by the dealer, or if this date cannot be established, the date the product was sold by **StrikeMaster Corporation** to the distributor or dealer.

THE IMPLIED WARRANTIES OF MERCHANTABILITY AND FITNESS FOR PARTICULAR PURPOSES ARE LIMITED TO THE DURATION OF THIS WARRANTY — One Year — AFTER SAID One Year **StrikeMaster Corporation** EXPRESSLY DISCLAIMS ANY WARRANTY OR MERCHANTABILITY OR FITNESS FOR ANY PARTICULAR PURPOSE.

Purchase or other acceptance of the product by the claimant shall be on the condition and agreement that **StrikeMaster Corporation** SHALL NOT BE LIABLE FOR INCIDENTAL OR CONSEQUENTIAL DAMAGES OF ANY KIND.

Some states do not allow limitations on how long an implied warranty lasts or do not allow the exclusion or limitations of incidental or consequential damages, so the above limitation or exclusions may not apply to you.

To make claim under this warranty write or call (763) 263-8999 directly to "CUSTOMER SERVICE", **StrikeMaster Corporation** at the above address for a warranty return authorization. **StrikeMaster Corporation** will make every effort to repair or replace the product if found to be defective within the terms of this warranty within 30 days after receipt of the product.

Proof-of-Purchase must accompany product to ensure warrantability.

NOTE: This warranty gives you specific legal rights, and you may also have other rights which vary from State to State.

Warranty Registration

This registration card must be returned to StrikeMaster Corporation to validate the One Year Limited Warranty. Register online at www.strikemaster.com/warranty.html

NAME _____ DATE PURCHASED _____

ADDRESS _____

CITY _____ STATE _____ ZIP _____

EMAIL ADDRESS _____

PRODUCT PURCHASED

SIZE

PURCHASED

SIZE

MORA Hand Auger

Lazer 224

Lazer Hand Auger

Electra Lazer 12000 DP

Lazer Mag Xpress

Strike-Lite

Mag 2000

PURCHASED AS A: Gift Own Use

PURCHASER: Male Female

PURCHASED AT: Local Dealer On-Line

AGE: _____

Catalog

Chain Store

Would you like future new product releases and information from StrikeMaster sent to your email?

Yes / No Email address _____

SM05

763-263-8999

www.strikemaster.com

Fax: 763-263-8986

SEE SPECIAL BROCHURE

- Replacement Blades
- Blade Exchange Service
- Blade Guards
- Auger Extensions
- Gift Ideas

STRIKEMASTER TUNE-UP SERVICE

Preventive maintenance of your TECUMSEH engine will assure you of many years of complete satisfaction and enjoyment of your StrikeMaster ice auger. Simply, send **FULL PAYMENT, plus \$10 for return shipping** and the engine assembly (only) to StrikeMaster, 17217 198th Avenue, Big Lake, Minnesota 55309. Before shipping, completely empty **ALL** fuel from the fuel tank, place engine in an appropriate container or carton and ship via small package delivery. (**DO NOT PACK WITH STYROFOAM PEANUTS**)

Special Tune-up

\$49.95 (April 1st - July 4th)

\$69.95 (July 5th - March 31st)

Parts & Labor Included

TECUMSEH – 49 cc Engine / 33cc

(Mag III, Mag 2000, Lazer Mag Xpress, Lazer 224 & Lazer Mag Ultra)

- Spark Plug
- Fuel Inlet Screen
- Intake Needle
- Metering Diaphragm
- Idle Adjustment
- Carburetor Kit
- Metering Lever
- Fuel Pump Diaphragm
- Gasket Set
- Throttle Adjustment

Optional Parts & Services

TECUMSEH – 49 cc Engine

(Mag III, Lazer Mag, Mag 2000, Lazer Mag Xpress, Lazer 224 & Lazer Mag Ultra)

- | | | | |
|--|---------|---------------------------------|---------|
| • Transmission Maintenance (no parts) | \$20.00 | • Recoil Repair (no parts) | \$25.00 |
| • Throttle Cable & Lever (Delta Wing Handle)
(Part #151477) | \$15.00 | • Air Filter (Part #450252) | \$ 5.00 |
| • Fuel Cap (Part #410285) | \$12.95 | • Fuel Tank Kit (Part #410284) | \$25.00 |
| • Fuel Line & Fuel Filter
(Part #410426A & 410263) | \$ 6.00 | • Throttle Rod Assembly | \$7.80 |
| | | Tufflite Handles (Part #151670) | |

Note: If you send your unit in for our Tune-Up Service, we will not perform any additional service or parts without first receiving your written or verbal pre-approval and pre-payment. If you have further concerns, or have any questions regarding our above mentioned services, please call during regular business hours (763) 263-8999 or write to StrikeMaster Corporation, P.O. Box 567, Big Lake, Minnesota 55309.

PLACE
STAMP
HERE

StrikeMaster Corporation

P.O. Box 567

17217 198th Avenue

Big Lake, Minnesota 55309