

# OPERATION and MAINTENANCE

of the

# M1 CARBINE

by

UNIVERSAL FIREARMS CORPORATION

THE ONLY LINE OF FIREARMS  
WITH THE FAMOUS

**3 YEAR**

**UNCONDITIONAL GUARANTEE**

against defects in materials and workmanship  
(wood excepted)

UNIVERSAL FIREARMS CORPORATION

3746 E. 10th Ct. — Hialeah, Florida

Loosen band screw—**P**.  
Depress band retainer—**Q**.

Slide band—**R**—forward until it clears upper and lower stock halves.  
Lift barrel/action assembly up by muzzle until action can be removed from under the rear action retainer—**S**.

## DISASSEMBLY —

### "Field Stripping"

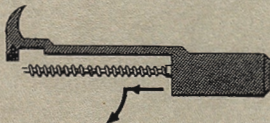
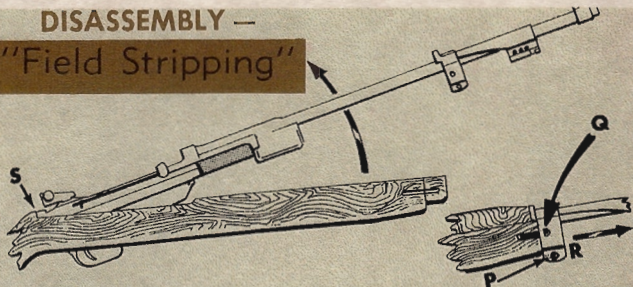

Draw recoil spring guide slightly to rear until it is disengaged from operating slide, and then pull to right and forward and withdraw guide and spring from well in receiver.

Remove trigger housing retaining pin (if pin sticks, use operating spring guide as a punch). Slide trigger housing group forward off receiver.

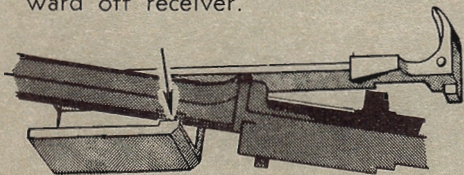
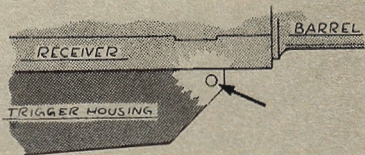

Pull operating slide slowly to rear until forward face of operating slide stop is in line with rear face of bolt opening in top of receiver. This places guide lug on operating slide handle in line with notch in guideway. Pull

slide handle up and to right until guide lug is free of retaining groove. Move operating slide slightly forward to align left guide lug on heavy forward part of operating slide opposite relief cut (arrow) in retaining guideway on barrel. Then rotate operating slide counter-clockwise to free guide lugs from retaining guideway, and remove slide.

Grasp operating lug of bolt and draw bolt to rear until its face is just back of receiver locking shoulders. Rotate bolt counter-clockwise to disengage it from left guideway in receiver. Then rotate bolt clockwise, and lift it up and right to remove from receiver. This is the last step in field stripping.

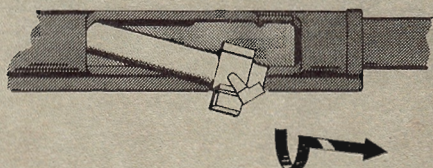

**CLEANING** — The carbine bore can be cleaned only from the muzzle. Before cleaning bore, remove magazine, and pull operating slide to rear and lock in this position by depressing operating slide stop. Then inspect chamber to make sure that it is not loaded. Use cleaning rod, which is available from arms dealers, and guide rod with thumb and finger to prevent damaging rifling at muzzle. Inspect bore with aid of a bore reflector, small mirror or piece of white cloth or paper placed in breech opening at an angle to reflect light. With bore reflector or mirror bore can be inspected from both ends. Carbine cartridges have noncorrosive primers and therefore it is not necessary to use water in cleaning the bore. However, nitro-solvent or bore cleaner should be used to dissolve powder fouling. Dry bore with clean patches after use of nitro-solvent or bore cleaner, and oil bore with patch soaked in preservative oil. Be sure to remove grease or any obstructions from bore prior to firing.

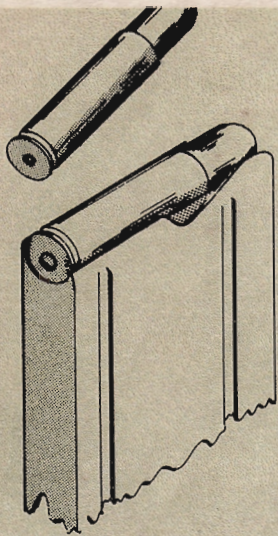

## LOADING —

Press cartridge down with thumb until caught under magazine lips. Repeat until full. Turn safety — **H** — down to SAFE (green exposed) Push magazine up into receiver until a click indicates the magazine lock has snapped into place. Pull operating slide handle — **J** — back and release it — thereby chambering first cartridge. It is a good habit to strike handle with heel of hand to make certain bolt is firmly seated and locked. Turn safety back to FIRE (red exposed).

## UNLOADING —

Turn safety down to SAFE (green exposed).

Press magazine lock — **K** — in.

Slide magazine down and out.

Pull operating slide back to eject remaining cartridge.

Operating slide may be retained in the open position by depressing the slide lock button — **L** — located on top of handle — so it engages the indent on receiver. To allow slide to return forward — simply apply rearward pressure on handle. Slide lock button — which is spring loaded — will automatically disengage itself.

Magazine is unloaded by sliding cartridges forward and out, one at a time.

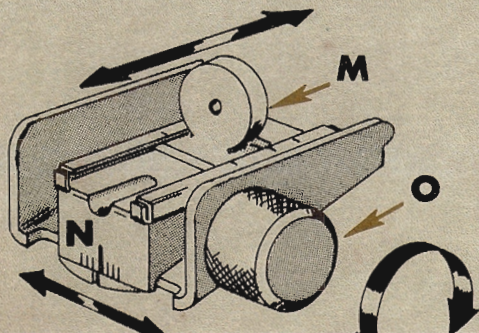
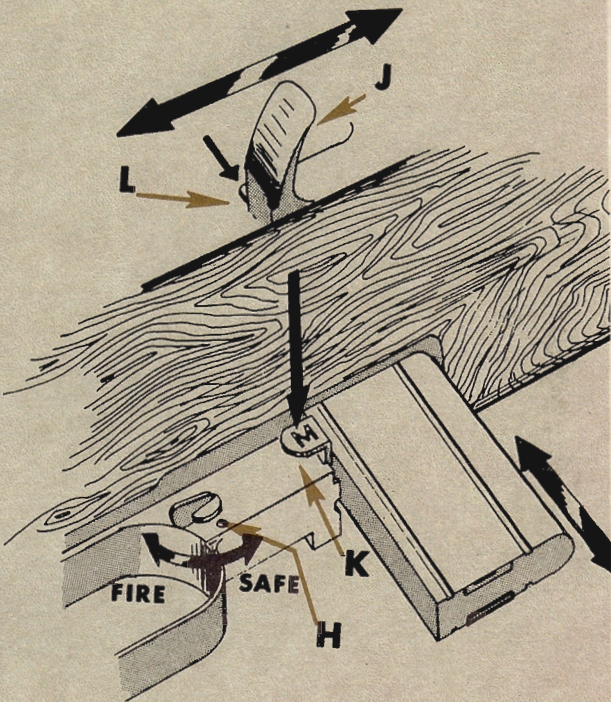

## SIGHTING —

Front sight is of the fixed blade type. Rear sight is of the "peep" or aperture type and is adjustable as follows:

Aperture — **M** — slides forward and rearward according to distance to target, and snaps into indents corresponding to 100, 200, 250, and 300 yards.

Ramp — **N** — moves left and right, by turning knob — **O** — to correct for windage, or lead on moving target. Each click corresponds to 1" at 100 yds. (2" at 200 yds., etc.).

## SPECIFICATIONS

Weight of carbine M1 with 15-round magazine (unloaded)	5.50 lb.	Weight of bullet (aprx)	111 gr.
Weight of Carbine M1 with 15-round magazine (loaded)	6.10 lb.	Muzzle velocity	1,900-2,000 f.p. s.
Magazine capacity	15 rd.	Pressure in chamber per square inch maximum (aprx)	40,000 lb.
Weight of 15-round magazine (unloaded)	0.17 lb.	Maximum range	2,000 yd.
Weight of 15-round magazine (loaded)	0.59 lb.	Effective range	300 yd.
Over-all length of carbine M1	35.58 in.	Length of barrel	18.00 in.
Over-all length of carbine M1 with bayonet attached	42.26 in.	Sight radius at 100 yards	21.5 in.
Weight of 100 cartridges	2.8 lb.	Trigger pull	4 1/2-7 lbs.
Weight of 1 ball cartridge	193 gr.	Sights: Front blade protected by wings; rear peep sight adjustable for windage and elevation.	
		Type of Fire: Single shot only. Pressing the trigger fires the cartridge, ejects the empty case, loads in a new cartridge and leaves the weapon cocked and ready for next pull of trigger.	

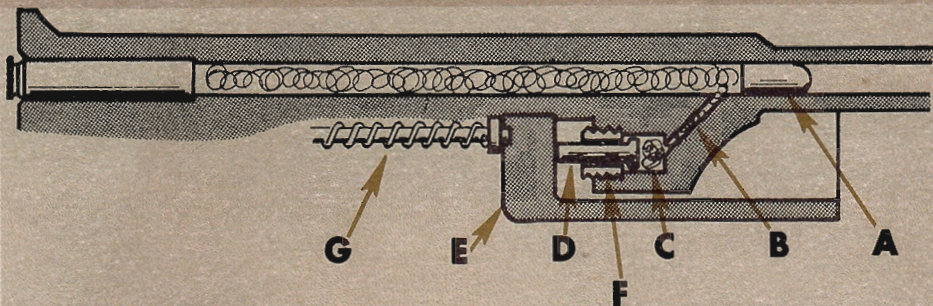

### OPERATION —

The carbine is gas-operated and has a short stroke action. As soon as bullet **A** is forward of gas port **B** in barrel, gas from the burning powder expands through gas port into gas cylinder **C** and thrusts the piston **D** rearward. The piston strikes the operating slide **E**, starting it into motion, and the piston is stopped after about 3/16" of travel by the piston nut **F**. As the operating slide starts to the rear, the recoil spring **G** begins to be compressed. The operating slide moves rearward about 5/16" before its cam contacts operating lug of bolt. This allows operating slide to gain speed to overcome inertia of the locked bolt, and also gives time for bullet to clear muzzle, allowing pressure in barrel to be reduced to outside pressure before bolt begins to unlock. As operating slide continues to the rear, it compresses the recoil spring and cams the bolt counterclockwise to unlocked position. Extraction and ejection of fired cartridge case, withdrawal of firing pin to safe position inside bolt, and cocking of hammer occurs as bolt moves rearward. When operating slide and bolt move forward, pushed by the compressed recoil spring, the bolt strips top round from magazine and shoves it into chamber. When bolt reaches forward position, cam in operating slide rotates bolt clockwise so locking lugs on either side of bolt head engage locking shoulders in receiver.

## PARTS LIST WITH PRICES

1	Butt Plate Screw	.12
2	Butt Plate	2.50
3	Stock	16.50
4	Slide Lock	.20
5	Slide	9.00
6	Slide Lock Spring	.12
7	Rear Action Retainer Bolt	.50
8	Rear Action Retainer	3.00
* 9	Receiver	25.00
10	Recoil Spring	1.00
11	Extractor	3.00
12	Firing Pin	2.75
13	Bolt (stripped)	9.00
* 13A	Bolt Assembly	16.50
14	Extractor Spring	.12
15	Extractor Spring Plunger	.25
16	Ejector Spring	.12
17	Ejector	.75
18	Rear Sight	5.00
19	Gas Piston Nut	1.50
20	Gas Piston	1.50
21	Hand Guard	4.00
* 22	Barrel	22.00
23	Recoil Spring Guide	1.00
24	Barrel Band Retainer	1.00
25	Barrel Band	4.00
25A	Deluxe Barrel Band	6.00
26	Front Sight	3.50
27	Front Sight Key	.20
28	Front Sight Pin	.12
29	Trigger Guard Pin	.20
30	Sear	4.50
31	Hammer	4.50
32	Hammer Spring Glide	1.75
33	Trigger Housing	7.50
33A	Trigger Housing Assembly	25.00
34	Magazine Lock	
	Retaining Spring	.12
35	Magazine Lock Retaining	
	Spring Plunger	.12
36	Magazine Spring	.12
37	Magazine Lock Spring Plunger	.12
38	Magazine Lock	2.50
39	Trigger Pin	.12
40	Safety	2.50
41	Hammer Pin	.12
42	Rear Action Retainer Nut	1.00
43	15 Shot Magazine	4.50
44	Trigger	4.00
45	Sear Spring	.12
46	Hammer Spring	.40
47	Trigger Spring	.50
** 48	Canvas Scabbard	3.00
** 49	Sling & Oiler	3.00
** 50	5 Shot Magazine	4.50
* * 51	30 Shot Magazine	8.00
	Nickle or Gold Plate	
* * 53	5 Shot Magazine	5.75
* * 54	15 Shot Magazine	5.75
* * 55	30 Shot Magazine	10.00
56	Side Base and Screws	1.50
57	4X Scope	24.95
58	Scope Mount & Rings	7.95

\* Return to Factory for service

\*\* Not shown in illustration

Prices Subject to Change without Notice

Add 25c postage under \$5.00, over

## SERVICE —

Every M1 Carbine is proof-tested and function-fired in order to prove that it is in perfect condition and conforms fully to our specifications and standards before shipment.

If there is any question with regard to the performance of the gun, please write to our Service Department, fully describing all circumstances and conditions involved.

If you should return your M1 Carbine for repair or if you order component parts, please comply with the following suggestions for prompt service:

1. Please enclose remittance with order.
2. Guns shipped to the factory should be sent prepaid. We will not accept collect shipments.
3. If no work is required on the stock, the complete barrel, receiver and mechanism may be sent alone.
4. Always give serial number and model of firearm. Give detailed information covering difficulty or work desired. Give name of shipper, if other than correspondent. Be sure to order parts by name and number.

SPECIFICATIONS SUBJECT TO CHANGE AT OUR DISCRETION WITHOUT NOTICE.

Please: Check Chamber and Magazine Before Shipping Firearm.

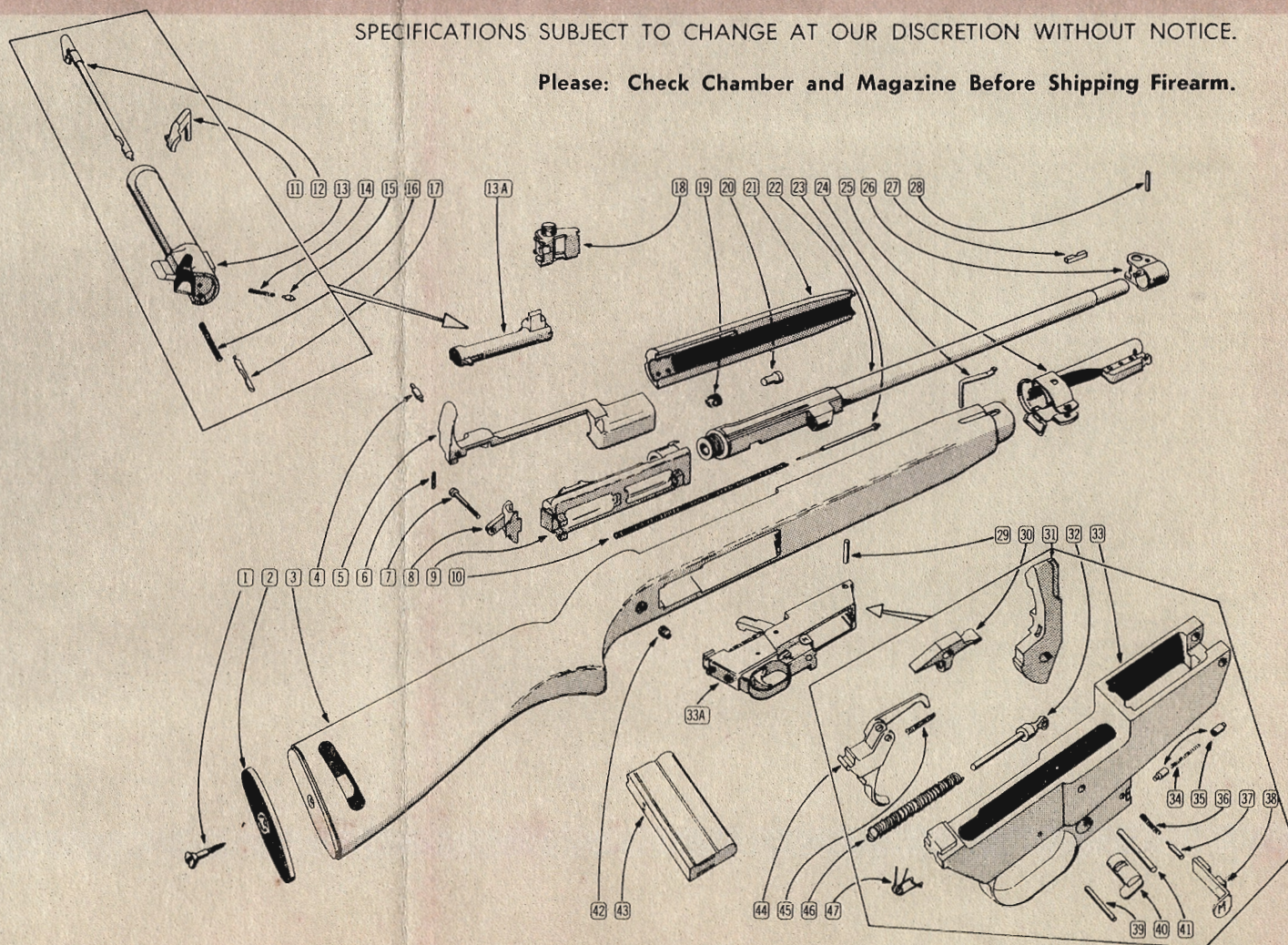

## SCOPE MOUNTING INSTRUCTIONS

Your new UNIVERSAL GUN has been drilled and tapped for a scope mount. The base mount and screws are enclosed in the box with your gun. Follow the simple directions to insure best results.

NOTE: Although base mount and screws are enclosed, Scopes are not enclosed with all models.

Remove action from stock as in Fig 1., and plastic insert used to protect screw holes and inletted area will slip out. as in Fig. 2.

Fasten base (1) to receiver with four screws (2) extremely tight, as in Fig. 3. Gunsmiths often apply one of the many two-part Epoxy metal bonding cements (available at variety stores) to the screws and under the base for greater security. Tighten each of the four base cap screws a little at a time until all are very tight so there can be no slippage. The rifle is then ready for sighting in.

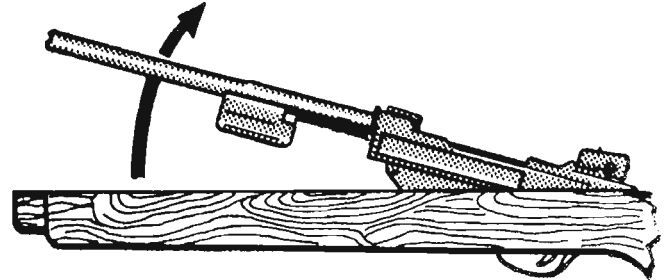

Figure 1

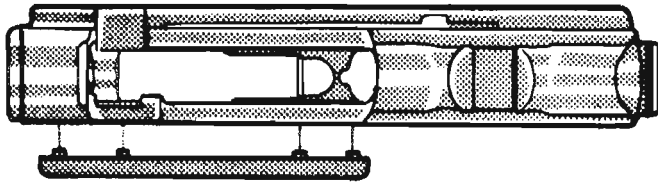

Figure 2

Fasten the mount (6) in position on the base. Place the gun in a vice or some fixed position with the bore or regular sights precisely aligned on a target about 40 feet distant. To boresight rifles, look through the barrel by means of a small piece of mirror held at an angle in the breech. Without moving the rifle from its boresighted position, the scope should point at or close to the boresight mark. This gives a close check on scope alignment.

**Removing Scope.** Loosen the two thumb screws (7) until they are free of the base and the scope and mount bracket can be lifted off. When replacing, tighten securely to prevent loosening from recoil or rough handling.

Before attaching the mount or boresighting, be certain the scope's windage and elevation adjustments are zeroed or centered so the line sight is parallel to the scope tube. (See your scope instructions.)

The scope turret (3) must be forward of the mount (4). Slip the mount caps (5) over the tube, don't remove the scope turret or eyepiece. (as in figure 4).

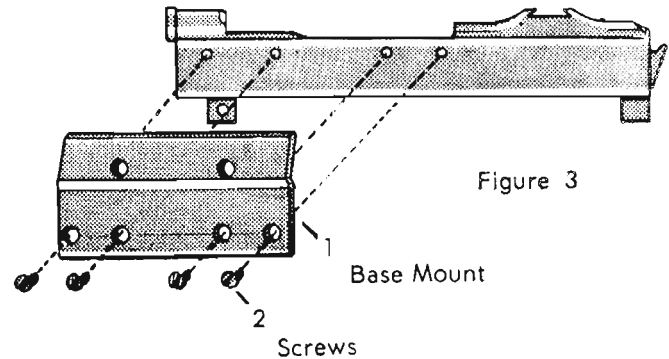

Figure 3

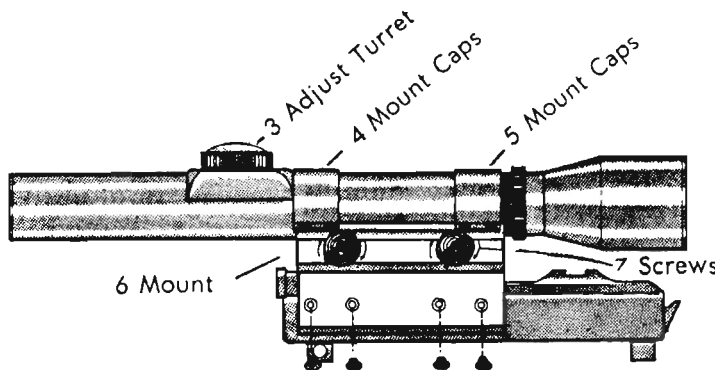

Figure 4

### IMPORTANT

The slightest movement of the scope or mount will cause the gun to shoot inaccurately. Everything must be tight - lens cells, base screws, mount cap screws, turret screws. All screws are hardened, turn them as tight as you can with a screw driver having a medium large handle and a well fitting, hardened blade. If necessary, grind it to fit the screws. A good mounting job will hold the scope rigidly so there can be no slippage or movement between any of the parts, and will hold the scope in accurate alignment with the gun barrel so the windage and elevation adjustments remain centered after sighting-in.

## SIGHTING IN

If gun shoots low at 100 yards with rear sight in the 100 yard position, follow these simple instructions:

Hold barrel firmly and file front sight blade  $1/16$  inch and test fire again. If gun continues to shoot low, file an additional  $1/16$  inch and fire again. Continue this procedure until gun shoots 100 yards accurately with rear sight in the 100 yard position.

Your .30 Cal. M-1 carbine rear sight has elevation positions marked in 100's which must correspond to the height of the front sight.

The front sight should be adjusted to the rear sight elevation numbers (the yardage, 100, 200, 250, 300).

Always remember to MOVE THE REAR SIGHT IN THE DIRECTION YOU WANT THE BULLET TO MOVE. For instance, if the gun shoots to the right, move rear sight to the left.

After the sight is filed, you may touch up with cold blue.

## AMMUNITION

We have used standard government surplus ammunition in testing this gun. If a re-loaded shell is being used, be certain that it is properly sized for perfect gun operation.

**UNIVERSAL FIREARMS CORPORATION**  
**Hialeah, Florida**