

**OPERATION, MAINTENANCE AND
MONITORING MANUAL**

**SILVER CHOLLA MOBILE HOME PARK WELL
5000 N. LA CHOLLA BLVD
TUCSON, ARIZONA**

JULY 11, 2019

**Prepared for:
Arizona Department of Environmental Quality**



HARGIS + ASSOCIATES, INC.
HYDROGEOLOGY • ENGINEERING

OPERATION, MAINTENANCE AND MONITORING MANUAL

ARIZONA DEPARTMENT OF ENVIRONMENTAL QUALITY

SILVER CHOLLA MOBILE HOME PARK WELL

5000 N. LA CHOLLA BLVD

TUCSON, ARIZONA

TABLE OF CONTENTS

Section	Page
ACRONYMS AND ABBREVIATIONS	iii
1. 0 EMERGENCY AND OTHER CONTACT NUMBERS	1
1.1 EMERGENCY CONTACTS.....	1
1.2 OTHER CONTACT NUMBERS.....	1
2. 0 INTRODUCTION/BACKGROUND.....	2
2.1 REMEDIAL OBJECTIVES AND REQUIREMENTS	2
3. 0 SITE AND SYSTEM DESCRIPTION	3
3.1 OWNERS, CLIENTS, AGENCIES AND UTILITIES	3
3.2 OPERATIONAL PERMITS	3
3.3 ORIGINAL WELL SYSTEM.....	3
3.4 WELL HEAD TREATMENT SYSTEM.....	4
4. 0 OPERATING PROCEDURES.....	6
4.1 START-UP AND SHUT-DOWN PROCEDURES	6
4.2 START-UP AND SHUT-DOWN PROCEDURES	6
4.3 NORMAL OPERATING PROCEDURES	7
4.4 PERIODIC MONITORING AND MAINTENANCE	7
4.5 LGAC VESSEL BREAKTHROUGH AND PROFILING PROCEDURE	9
4.6 REPORTING PROCEDURES.....	10
4.7 CARBON CHANGE-OUT PROCEDURES	10

TABLE OF CONTENTS (continued)

FIGURES

Figure

- 1 SITE LAYOUT
- 2 MANIFOLD
- 3 LEAD LAG VALVE SETUP
- 4 SINGLE VESSEL VALVE SETUP

APPENDICES

Appendix

- A EQUIPMENT SPECIFICATIONS
- B INSPECTION FORMS

ACRONYMS AND ABBREVIATIONS

ADEQ	Arizona Department of Environmental
EPA	U.S. Environmental Protection Agency
ERA	Early Response Action
gpm	gallons per minute
lb	pound
LGAC	liquid granular activated carbon
LOTO	lock out/tag out
MCL	maximum contaminant level
OMM	Operation, Maintenance and Monitoring
psi	pounds per square inch
TCE	trichloroethene
µg/l	micrograms per liter
VOC	volatile organic compound

OPERATION, MAINTENANCE AND MONITORING MANUAL

ARIZONA DEPARTMENT OF ENVIRONMENTAL QUALITY
SILVER CHOLLA MOBILE HOME PARK WELL
5000 N. LA CHOLLA BLVD
TUCSON, ARIZONA

1.0 EMERGENCY AND OTHER CONTACT NUMBERS

1.1 EMERGENCY CONTACTS

An emergency is an uncontrolled situation, an injury that is life threatening, fire, or anything that requires immediate assistance from the fire department, emergency medical services, or police department.

- In the event of an emergency, call 911. After notification to 911, call the Owner Contact and the Arizona Department of Environmental Quality (ADEQ).
- ADEQ: Hazel Cox, (520) 770-3125; (520) 784-1708.

1.2 OTHER CONTACT NUMBERS

For all other non-emergency situations contact phone numbers are:

- ADEQ: Hazel Cox, (520) 770-3125; (520) 784-1708.
- Operation, Maintenance and Monitoring (OMM) Contractor: Chris Perkovac, Hargis + Associates (619) 241-3575.
- System Operator: Wendy Gort (520) 404-0994 or (520) 896-2190

2.0 INTRODUCTION/BACKGROUND

This Operation, Maintenance and Monitoring (OMM) Manual is prepared to provide system information required to efficiently operate, maintain and monitor the Silver Cholla Mobile Home Park Supply Well treatment system located at 5000 N. La Cholla Blvd, Tucson, Arizona (Figure 1). The operation of the treatment system is performed as an early response action (ERA) for the Miracle Mile Water Quality Assurance Revolving Fund site. In 2018, a water sample from the storage tank contained trichloroethene (TCE) at a concentration of 6.2 micrograms per liter ($\mu\text{g/l}$), over the Environmental Protection Agency (EPA) primary drinking water maximum contaminant level (MCL) standard of 5 $\mu\text{g/l}$. The well owner was contacted and informed of the results. The system was turned off and the city water connection was opened to supply water to the trailer park until installation of a well head treatment system could be conducted. ADEQ installed a well head groundwater treatment system for the removal of volatile organic compounds (VOCs) to facilitate continued use by the trailer park as a potable water supply.

This OMM Manual is subject to change and or modification to account for changes to the system.

2.1 REMEDIAL OBJECTIVES AND REQUIREMENTS

The remedial objectives of the well head treatment system is to remove TCE to a concentration below 5.0 $\mu\text{g/l}$. The operating requirements of the treatment system are:

- maintain an approximate flow rate between 50 to 200 gallons per minute (gpm) from the supply well for treatment and
- provide treated water with VOC concentrations below the EPA primary drinking water MCL standards.

3.0 SITE AND SYSTEM DESCRIPTION

3.1 OWNERS, CLIENTS, AGENCIES AND UTILITIES

The components of the original system are owned, maintained and operated by the property owner. The property owner has contracted Wendy Gort to perform system operator activities including periodic monitoring and reporting. The mobile home park water distribution system is supplied primarily from the Silver Cholla Supply Well (Supply Well); however, if needed a connection to Tucson Water can be opened to supply potable water. Electrical power is supplied by a meter base located several feet east of the Supply Well.

The newly installed well head treatment system; including pipelines, manifold and liquid granular activated carbon (LGAC) vessels is owned and operated by ADEQ. ADEQ has sub-contracted operation and maintenance of the well head treatment system to Hargis + Associates (OMM Contractor). Contact information is provided in Section 1.0.

3.2 OPERATIONAL PERMITS

The existing system is owned by the Silver Cholla Mobile Home Park who is responsible for maintaining permits, amending permits, monitoring, and other compliance issues. The treatment system was installed by ADEQ as an Early Response Action (ERA) which does not require obtaining construction permits.

3.3 ORIGINAL WELL SYSTEM

Prior to installation of the well head treatment system the original well equipment setup (Original System) included a turbine well pump with an at grade electric motor. Groundwater is pumped to the surface and discharged to a 2,000-gallon surface storage tank. A check valve and flow meter were located on the pipe from the well to the storage tank. A pressure gauge, attached to the storage tank, measured the air pressure within the tank. The gauge was set to turn on the well pump when the tank pressure dropped to 32 pounds per square inch (psi) and to turn off when it reached 50 psi. A Schrader valve on the discharge pipe let air in the pipe line as the pump turned off and the water level in the pump riser dropped. The Original System included:

- groundwater extraction well (55-600238; 10-inch diameter; total depth 355 feet);
- turbine well pump (model M8MC, 12 stages, 200 gpm) with an above ground electric motor;
- electrical meter and fuse box;
- storage tank with pressure gauges and air vents;
- totalizer and flow meter (McCrometer Flowmeter);
- check valve;
- 3-inch pipeline from pump to storage tank;
- 3-inch pipeline from storage tank to residences;
- Water sample point id: "ADEQ-EPDS-001 ".

The only equipment removed during the installation of the well head treatment system was the Schrader valve.

3.4 WELL HEAD TREATMENT SYSTEM

A well head treatment system was installed to remove VOCs from groundwater prior to the storage tank. The existing pipeline from the well to the storage tank was spliced into directing water from the pump to the treatment system and then to the water storage tank (Figure 1). The well head treatment system receives groundwater from the supply well, removes VOCs by passing over activated granular carbon, and pipes the treated water to the storage tank. The treatment system requires no booster pumps. The treatment system is designed to passively operate with the existing system and does not require day to day maintenance and/or oversight. The well head treatment system includes:

- A 15-foot by 10-foot and 6-inch thick concrete pad with a broom surface finish. The pad is reinforced with rebar. There is no curbing to trap or direct surface water.
- 3-inch galvanized carbon steel above-ground pipeline mounted on pipe supports.
- CS Manifold stationed between and in front of the LGAC vessels (Figure 2). It is connected to the vessels and conveyance piping with 3-inch hoses. The manifold has three flange connections for: input, output, and washout. The manifold is fitted with 8 control valves, four pressure gauges (Evoqua 0-100psi 316SS) and four sample points.

- Hoses from the manifold to the piping and LGAC vessels. Hose is 3-inch drinking water rated hose with CAM locks.
- Two 2,000 pound (lb) LGAC vessels manufactured by Evoqua.
- Overpressure relief valve(s).
- Air compressor mounted on top of supply tank. The compressor is operated by a timer for 30 minutes of operation per day.

In early 2019 the well head treatment system was installed. A concrete pad was installed adjacent to the existing storage tank for the placement of the LGAC vessels and the CS manifold (Appendix A). Aboveground 3-inch pipelines attached to supports were installed from the pump to the treatment system. Prior to system startup the property owner replaced the electrical box for the pump. The LGAC vessels and CS manifold were placed on the concrete pad. The LGAC vessels were loaded with granulated carbon provided by EVOQUA. Prior to being placed back online, the system was tested by running the groundwater through the LGAC vessels, to the storage tank and then emptied to the sewer. Water at the storage tank and leaving the LGAC vessels was analyzed for bacteria. Tests showed the presence of bacteria. To clean the system the well and storage tank were chlorinated and the LGAC system was caustic washed. After the cleaning the system was tested and bacteria was not present. VOC analysis of treated water was non-detect for VOCs.

4.0 OPERATING PROCEDURES

4.1 START-UP AND SHUT-DOWN PROCEDURES

In the event of a system failure or if it is suspected that the water quality is not meeting public health standards the well will be immediately shut down by closing the valve from the storage tank to the mobile home park and turning off the electricity to the pump and air charger. The well owner, ADEQ and system operator will be immediately contacted and informed of the situation. At the well owner's discretion, the connection with the municipal water system may be opened to provide water to the mobile home park. The well owner will then immediately contact appropriate authorities to inform them of the situation. ADEQ and/or the park owner will assess the system and/or water quality issues, and provide recommendations. The park owner will take necessary steps to provide water and protect the human health.

4.2 START-UP AND SHUT-DOWN PROCEDURES

Start-up and shut-down procedures presented in this section should be followed when turning on or off the treatment system. ADEQ and the well owner shall endeavor to coordinate with each other for system start-ups and shut-downs. This includes a 24-hour notification by email or phone call to ADEQ and/or the well owner prior to system start-ups and shut-downs. Some of these procedures may not be required if the system is temporarily shut down for routine tasks, maintenance, trouble-shooting, or any other tasks.

Startup Procedures

- Check all valves to ensure water will flow through the system as directed (Figures 3 and 4);
- Record condition of all valves (open/closed) (Appendix B);
- Remove Lock-out, Tag-out (LOTO) safety equipment, if any;
- Turn on electrical system;
- Once system is operational and the pump is running, check totalizer to verify flow;
- Check valves on top of LGAC vessels for air. Open valve(s) to vent air if needed;
- Check the system for leaks; and

- Check valves to verify operating pressure (generally between 40 psi and 50 psi).

Shut Down Procedures

- Turn off the electrical supply to the well pump and install LOTO safety equipment;
- Close off valves as appropriate for system isolation as needed;
- Check gauges for pressure; Open pressure valves to release pressure as appropriate.

4.3 NORMAL OPERATING PROCEDURES

The well head treatment system is designed to passively operate with the existing system and does not require day to day maintenance and or oversight. As the pump turns on groundwater is pumped to the manifold which directs water to the top of the 1st (lead) LGAC vessel (Figure 3). Water flows from the top of the lead vessel through the LGAC and out the tank bottom. Water leaving the bottom of the lead vessel goes to the manifold which directs the water to the top of the 2nd (lag) vessel. Under normal operations VOCs are removed to levels below MCLs in the lead vessel. As the capacity of the LGAC in the lead vessel to remove contaminants decreases break-through of contaminants will occur. Break-through occurs when VOCs are detected leaving the lead vessel at concentrations equal to or greater than MCLs. At this point the lag vessel will remove contaminants to under the MCL prior to the storage tank. When break-through from the lead vessel is detected, a LGAC change out of the lead vessel will be conducted. After the change out, the manifold valves will be changed to switch the lead and lag vessels. The former lead vessel, in which new LGAC has been filled, will become the new lag vessel (Figure 3).

4.4 PERIODIC MONITORING AND MAINTENANCE

The well head treatment system will require periodic monitoring and maintenance to:

- Ensure system performance;
- Monitor for LGAC vessel breakthrough;
- Provide maintenance as needed;
- Change-out LGAC as needed; and
- Report observations.

The system must be visited, inspected and monitored at a regular frequency to assure the system continues to operate properly, safely, and efficiently. The frequency of these visits are detailed below. However, visits can also be dependent on system flows, carbon loading rates, timing of LGAC vessel breakthrough and other operational parameters and objectives. When conducting these routine tasks, the collected information will be recorded on the appropriate form(s) (Appendix B). Additional tasks may be required based on new operational conditions identified during these routine visits or review meetings. The schedule of inspections is:

- During the first year of operation the OMM contractor will visit the site every two-weeks to observe and document the system operation (Appendix B). Once every quarter a water sample will be collected from the: well discharge (Location W-1), water leaving the lead and lag LGAC vessels and analyzed for VOCs (Appendix B). A trip blank will be collected. No field blank and equipment blank samples will be collected. The sample collection is for the purpose of monitoring VOC removal efficacy. The samples will be provided to an Arizona Department of Health Services licensed environmental laboratory for analysis.
- After the first year of operation an ADEQ representative will visit the site monthly to observe and document the system operation. Once every quarter a water sample will be collected from the: well discharge (Location W-1 located prior to the LGAC system), water leaving the lead and lag LGAC vessels and analyzed for VOCs. A trip blank will be collected. No field blank and equipment blank samples will be collected.
- After breakthrough from the 1st vessel is detected a carbon change out will be scheduled and performed. A sample of the LGAC will be collected for disposal purposes (see below).
- It is the well owners' responsibility to monitor and sample the system for all other compliance issues as needed.

Each routine visit should include the following tasks:

- Record kWh meter total;
- Record system discharge flowmeter and flow rate (in gpm). The pumping flow rate should vary from 50 to 150 gpm.
- Record system pressures. LGAC gauges should be approximately 40 to 50 psi while the well is pumping. High or low readings may indicate: blockage, broken gauges, leakage.

- The storage tank pressure should range from 30 psi to 50 psi. The well pump turns on when the gauge is 30 psi and turns off when 50 psi is met. Minor slow air leaks in the storage tank will slowly cause the air pocket in the tank to decrease in volume. The air compressor is placed on a timer system to operate daily for approximately 30- to 45-minutes to re-fill the air pocket in the storage tank.
- Open valves on the top of each LGAC vessel to check for and release air.
- Note any signs of leakage and corrosion.

Maintenances Tasks: ADEQ and the well owner shall endeavor to coordinate with each other for significant system maintenance. This includes a 24-hour notification by email or phone call to ADEQ and or the well owner prior to significant system maintenance. Routine visit should include the following tasks:

- On a semiannual basis, the ADEQ Contractor shall conduct a housekeeping event at the Site including, but not limited to: sweep floors, dusting equipment, tidy all supplies and expendables, verify signage remains correct (replace if necessary), inspect for insect/rodent issues, etc.
- Exercise isolation valves on a bi-annual basis.
- Visually inspect for leaks and repair piping or equipment as needed.

4.5 LGAC VESSEL BREAKTHROUGH AND PROFILING PROCEDURE

Treatment system analytical data shall be reviewed by ADEQ and the OMM Contractor upon receipt from the laboratory. When breakthrough concentration at or near the MCL is detected from the lead vessel, the system should be temporarily shut down and the vessel opened to collect a "profile for disposal" sample. The LGAC change-out contractor should be contacted to provide sampling and profile requirements. In general a sample is collected by removal of the upper 6-inches of surface solids (crust material) and then using a decontaminated hand trowel to scoop the solid material into a laboratory provided container. This sample will be provided to the carbon supplier or laboratory for their use. In general the sample will be analyzed for toxicity characteristic leaching procedure for VOCs, however, the sampling method and analysis may be modified by the LGAC change-out contractor's requirements. If a valid profile already exists for the spent LGAC, it may not be necessary to sample the vessel. When the carbon supplier has completed the analysis of the sample, or if no sample is required, the carbon supplier should be contacted

immediately to arrange for a "remove and replace" service. The fresh LGAC must be ordered as pre-wetted (or "pre-soaked") and acid-washed. Use of non-pre-wetted and non-acid-washed LGAC will likely result in initial discharge water that exhibits a high pH. The system should be operated in the existing Lead/Lag mode until the LGAC in the lead vessel is changed.

4.6 REPORTING PROCEDURES

The following reporting will be performed:

- Once this OMM Manual has been approved the OMM Contractor shall prepare monthly reports for the treatment system on standardized formats. Reports will be provided to ADEQ, the well owner, and the system operator via email. Monthly reports will include observations from routine visit, sampling results, and anticipated future activities.
- The OMM Contractor will prepare annual reports for the treatment system on standardized formats. Reports will be provided to ADEQ, the well owner, and the system operator via email. Reports will include summary of tasks performed, system discharge summaries, breakthrough observations, laboratory reports, and anticipated activities over the next year.

4.7 CARBON CHANGE-OUT PROCEDURES

- Isolate lead vessel from system, using only lag vessel for treatment;
- remove and replace used LGAC (LGAC Contractor will be responsible for removing and replacing used LGAC in accordance with their own procedures);
- follow LGAC Contractors procedures prior to re-connecting with system;
- run water through the vessel and discharge to the sewer;
- collect and analyze effluent from vessel for BAT and VOCs; and
- if BAT is not present and VOCs are below MCLs, re-connect vessel as a lag vessel.

Prior to the scheduled LGAC change-out service, the lead LGAC vessel should be isolated and the water should be removed from the lead vessel by means of air pressure (Figure 4). Pressure should be controlled by use of a regulator set a pressure no greater than 20 psi. The regulator

output pressure should be pre-set so that it cannot exceed the working pressure of the vessel. The air should be introduced to the vessel slowly so that it approximates the normal flow parameters. The water from the lead vessel will be "pushed" by the compressed air through the lag vessel and to the sewer discharge.

When the carbon supplier arrives on site, a safety tailgate meeting will be held with all personnel and companies on site for this work. Delivery paperwork shall be inspected to assure that the correct LGAC type and sieve size has been delivered.

The carbon supplier will begin the removal of spent LGAC. This LGAC will be collected in sealed drums or truck-mounted containers. Spent carbon shall be contained in sealed containers, super-sacks are not permitted due to the potential for water leakage. The carbon supplier shall remove the spent carbon under a bill-of-lading or manifest for off-site disposal or recycling. Pickup of spent carbon shall be scheduled for the same day as the change-out.

When the spent LGAC has been removed, the OMM Contractor will visually inspect the interior of the vessel to verify that all LGAC has been removed. During this inspection, internal structures such as underdrains will be inspected to determine that no damage has occurred. The lining of the vessel will also be inspected to verify that the lining material is intact. The vessel shall also be inspected by the OMM Contractor after the LGAC has been installed in the vessel to verify that the proper amount of LGAC is in the vessel, and that the top of the LGAC is flat and even. The manway or lid seal should be inspected to assure it is in good condition. The vessel will be backwashed by the carbon supplier and water discharged to sewer. The changed-out vessel should then be filled with water from the well. The pressure relief valves on the LGAC vessel shall be opened to allow air within the vessel to escape while the vessel is being filled with water. Once the vessel is filled and the pressure relief valve is closed, it should be allowed to soak for a minimum of 24 hours. The vessel should be inspected for leaks. After the 24-hour soak, approximately 2,000 gallons of groundwater should be run through the vessel to sewer and then effluent from the vessel sampled for BAT and VOCs. The vessel shall be closed off (isolated) while the samples are tested. If BAT is not present and VOCs are below MCLs the vessel may be reconnected to the system. The system connections controlling the flow pathway should be configured so that the vessel with the fresh pre-wetted and acid-washed LGAC is placed in the

lag position. Signage should be changed to reflect the new relative positions of the vessels. The system should be observed by the OMM Contractor to verify normal operation.

If BAT is detected the vessel shall be caustic washed by the LGAC Contractor until no longer detected. If VOCs are detected above MCLs the OMM Contractor and LGAC Contractor shall determine the cause and take appropriate measures to correct.

FIGURES



SITE AREA

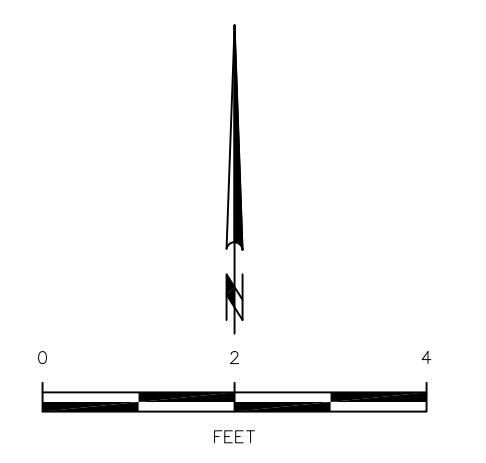
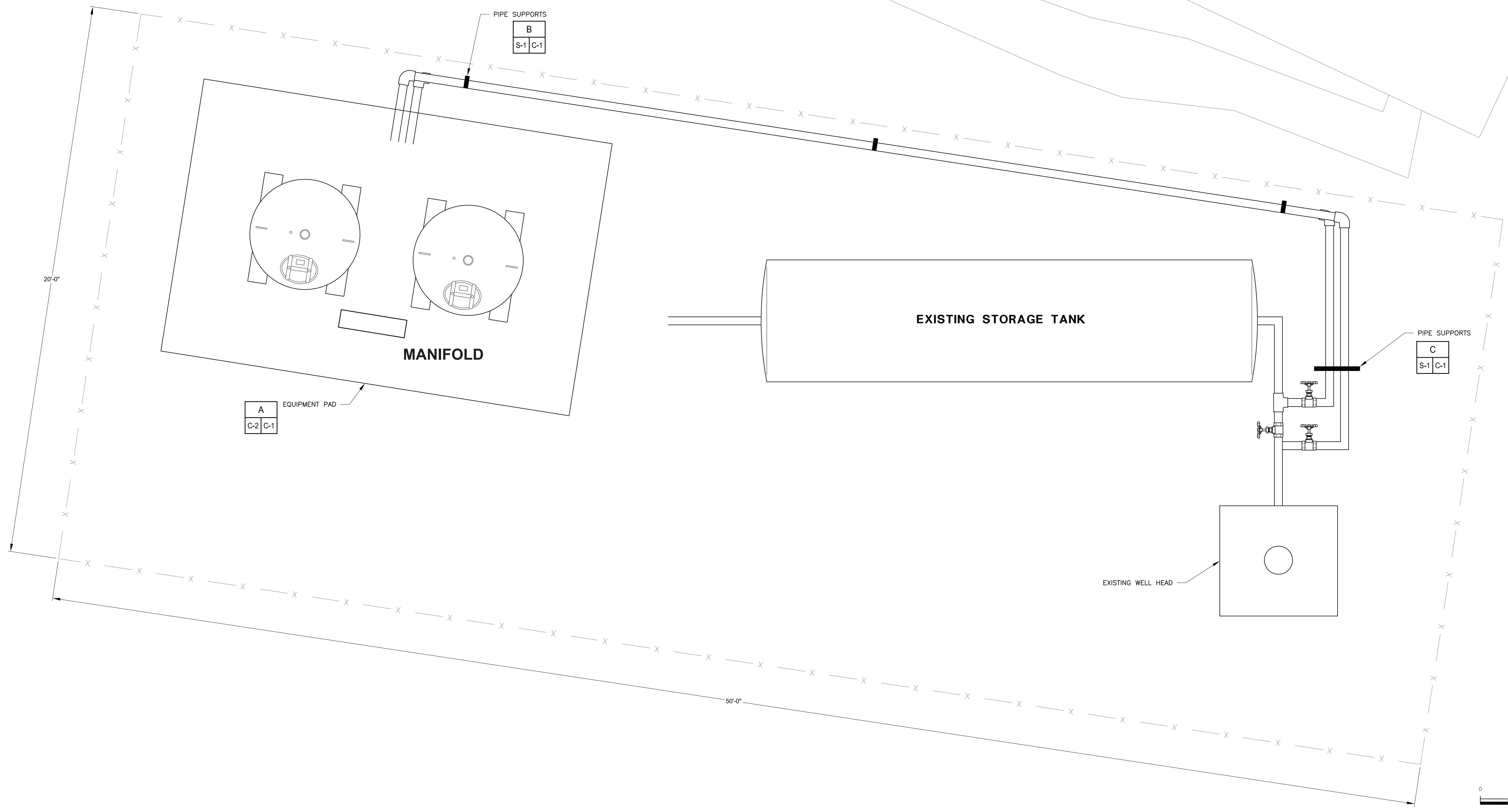

FIGURE 1: SITE LAYOUT

REV	ISSUE	CHK'D	PM	DE	DATE

HARGIS + ASSOCIATES, INC.
 9171 TOWNE CENTRE DRIVE, SUITE 375
 SAN DIEGO, CA 92122
 TEL (858) 455-6500
 FAX (858) 455-6533

ARIZONA DEPARTMENT OF ENVIRONMENTAL QUALITY
 TUCSON, ARIZONA
SILVER CHOLLA PUBLIC WATER SUPPLY SYSTEM
 5000 N LA CHOLLA BLVD
 TUCSON, AZ 85705
SITE PLAN

DATE: 11/20/18
 PROJECT NO: 1233.06
 FILENAME: 550-1193

SHEET: **C-1**

Nov 20, 2018 - 3:35pm EST - I:\2018\1233-06-1233_Maps\Map\LogSheet\C-1\550-1193.dwg

STD: BORDER-0106-8X11A

INTL REF:

BAR = 1" AT PLOT SCALE

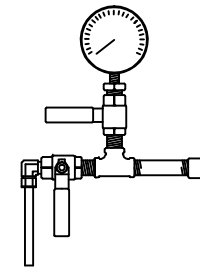
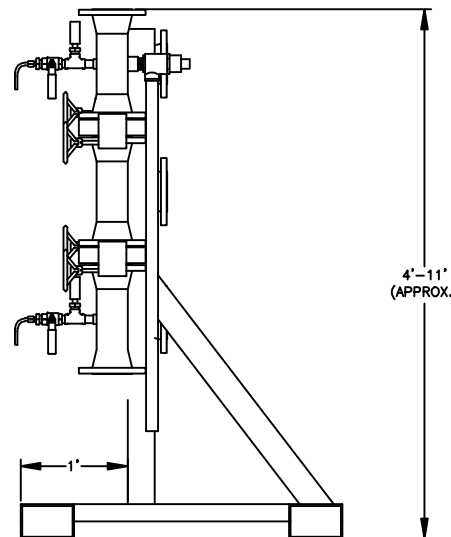
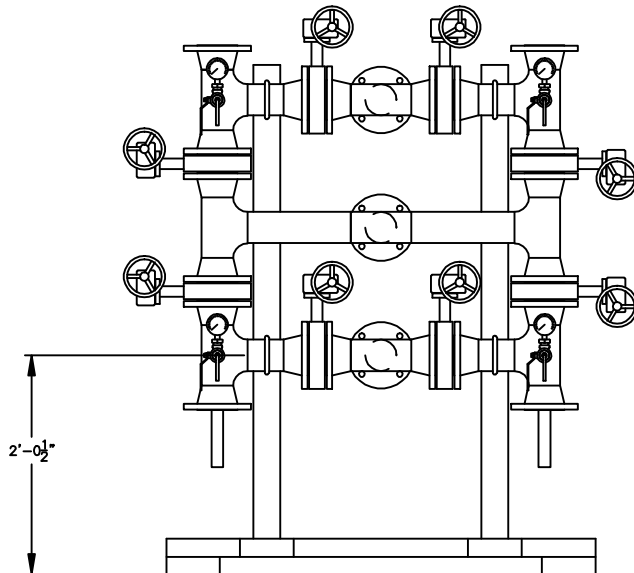
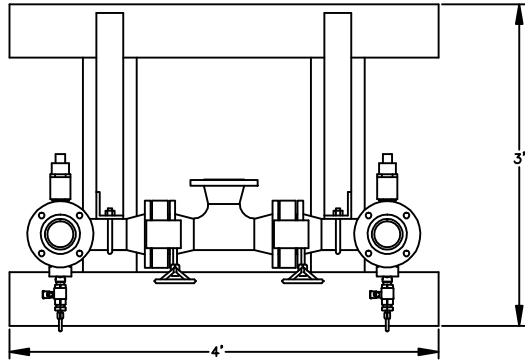

1/2" SAMPLE PORT
See Dwg. SP90ADAPT
(4 REQUIRED) NTS

* OPTIONAL BWO VALVE LOCATION

COMPANY CONFIDENTIAL
THIS DOCUMENT AND ALL INFORMATION CONTAINED HEREIN ARE THE PROPERTY OF SIEMENS AND/OR ITS AFFILIATES. THE DESIGN CONCEPTS AND INFORMATION CONTAINED HEREIN ARE PROPRIETARY TO SIEMENS AND ARE SUBMITTED IN CONFIDENCE. THEY ARE NOT TRANSFERABLE AND MUST BE USED ONLY FOR THE PURPOSE FOR WHICH THE DOCUMENT IS EXPRESSLY LOANED. THEY MUST NOT BE DISCLOSED, REPRODUCED, LOANED OR USED IN ANY OTHER MANNER WITHOUT THE EXPRESS WRITTEN CONSENT OF SIEMENS. IN NO EVENT SHALL THEY BE USED IN ANY MANNER DETRIMENTAL TO THE INTEREST OF SIEMENS. ALL PATENT RIGHTS ARE RESERVED. UPON THE DEMAND OF SIEMENS, THIS DOCUMENT, ALONG WITH ALL COPIES AND EXTRACTS, AND ALL RELATED NOTES AND ANALYSES, MUST BE RETURNED TO SIEMENS OR DESTROYED, AS INSTRUCTED BY SIEMENS. ACCEPTANCE OF THE DELIVERY OF THIS DOCUMENT CONSTITUTES AGREEMENT TO THESE TERMS AND CONDITIONS.

DESIGNER	DATE
CAR	3/23/06
CHECKER	DATE
ENGINEER	DATE
MANAGER	DATE
FILE:	
SCALE:	NONE

TITLE		3 INCH CS MANIFOLD	
CLIENT			
SIEMENS		WATER TECHNOLOGIES RED BLUFF, CA 530-527-2664	
PROJECT	CODE	DRAWING	SHEET
		MAN1003SHOP	1 OF 1
			REV

FIGURE 2: MANIFOLD

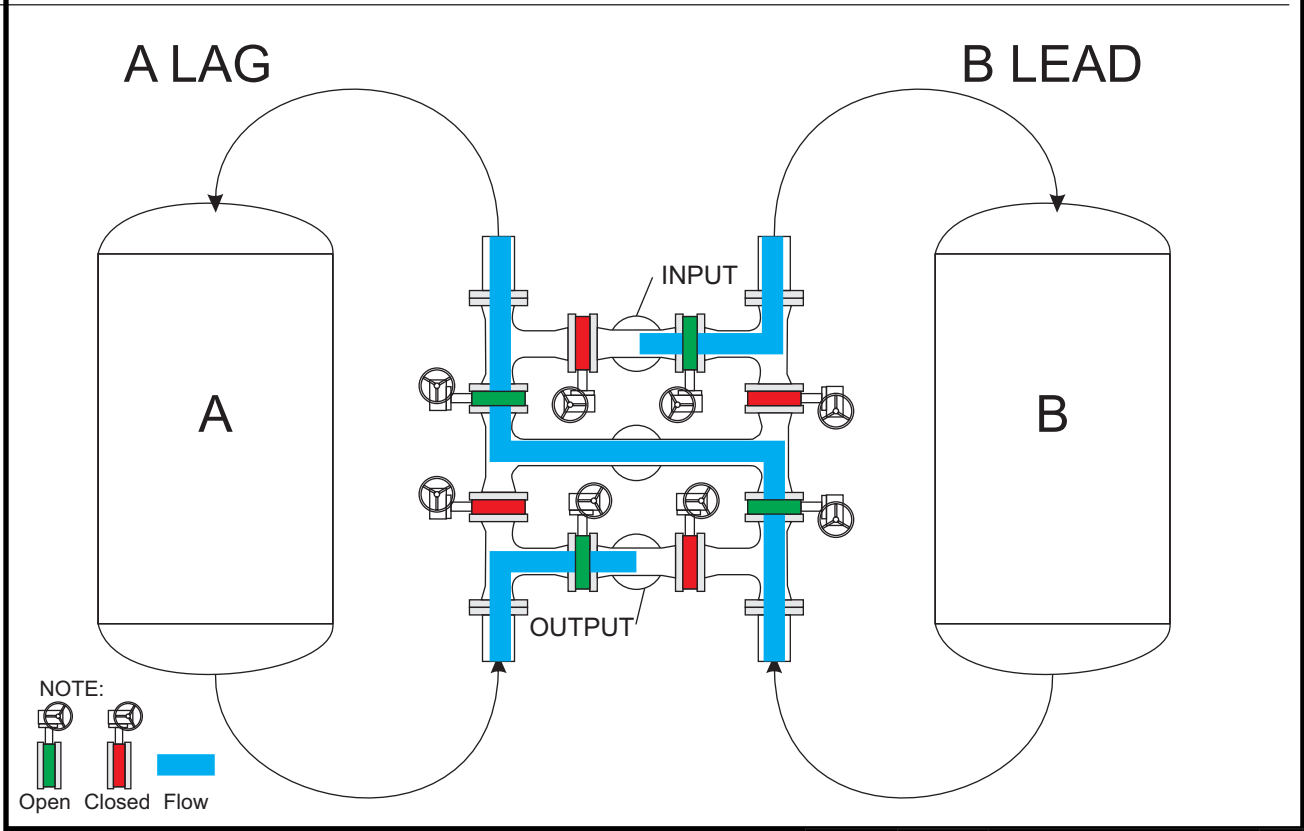
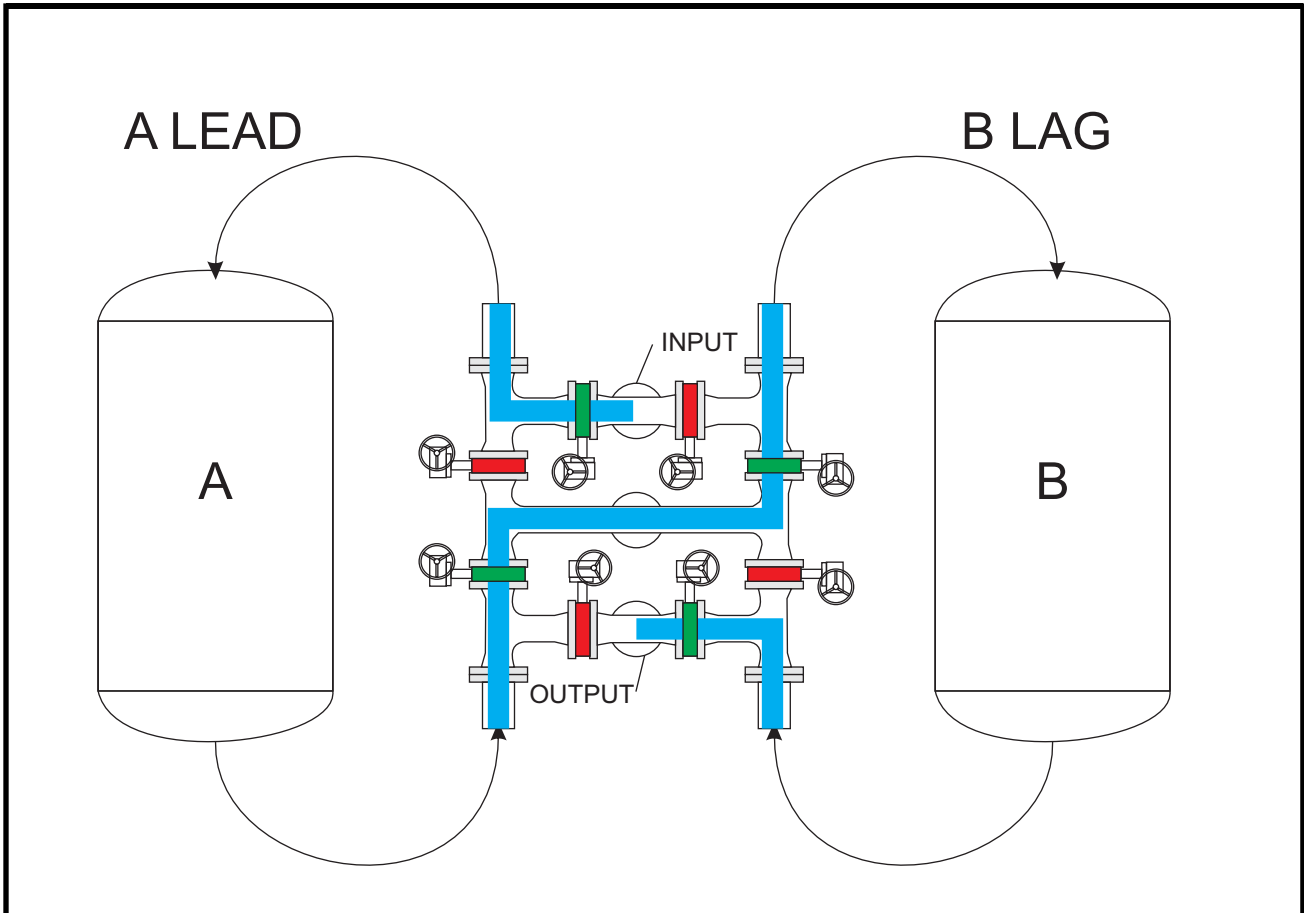

NOTE:

 Open Closed Flow

FIGURE 3: LEAD LAG VALVE SETUP

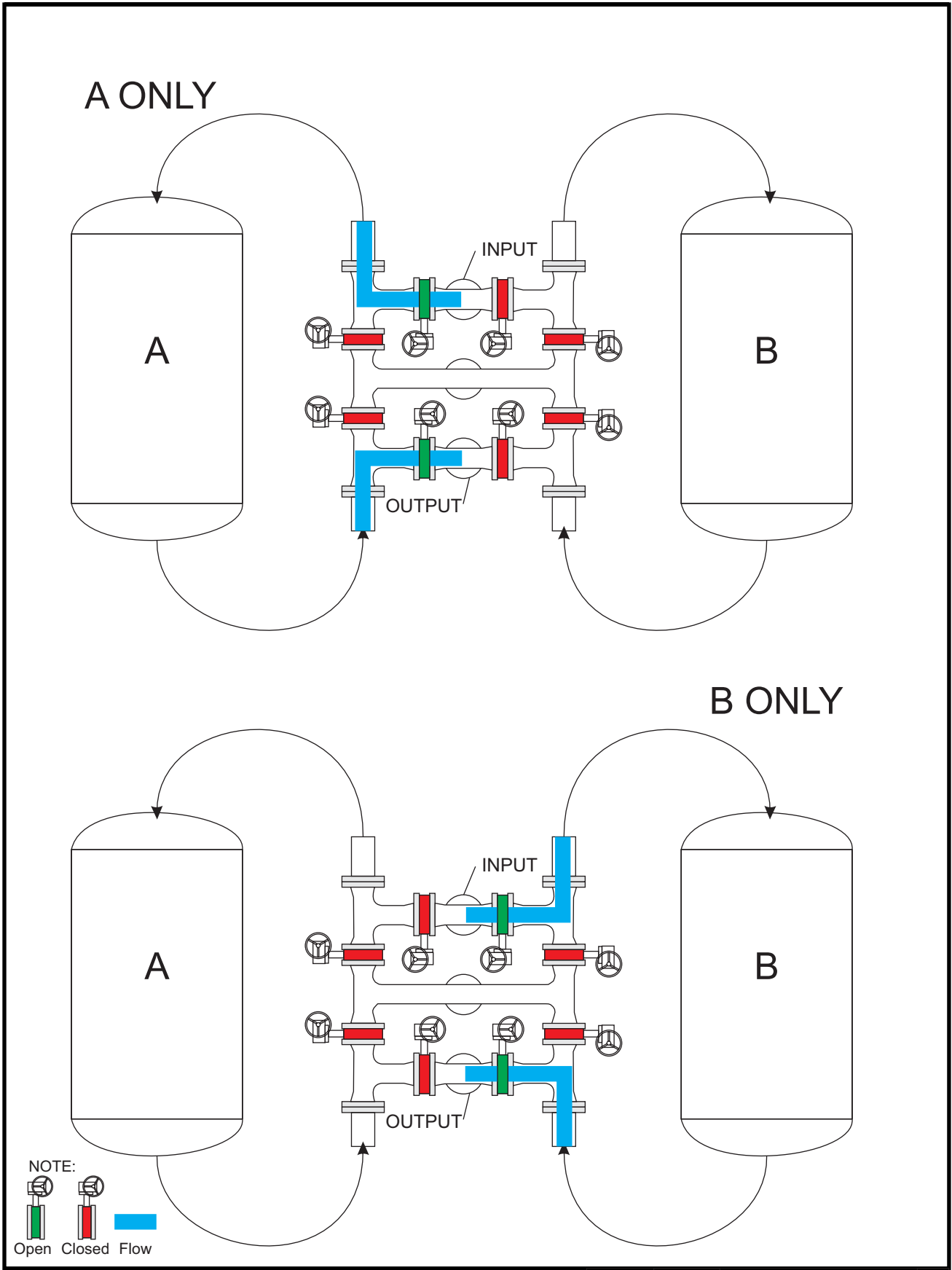

FIGURE 4: SINGLE VESSEL VALVE SETUP

APPENDIX A
EQUIPMENT SPECIFICATIONS



HARGIS+ASSOCIATES, INC.

ENGINEERING SPECIFICATION

SECTION NO.: 01 11 00

TITLE: SUMMARY OF WORK

PROJECT: MIRACLE MILE SILVER CHOLLA PUBLIC WATER
SUPPLY SYSTEM NO. AZ0420478

PROJECT NO.: 1050

COMPANY: ARIZONA DEPARTMENT OF WATER QUALITY

LOCATION: 5000 N. LA CHOLLA BLVDTUCSON, ARIZONA

0	APPROVED FOR BID	8					11/21/18
Rev.	ISSUE DESCRIPTION	PAGES	CL	EM	PM	DE	DATE

ENGINEERING SPECIFICATION	SUMMARY OF WORK SECTION 01 11 00	Project: <u>1233</u> Revision: <u>0</u> Date: <u>11/21/18</u> Page <u>2</u> of <u>8</u>
----------------------------------	---	--

PART 1 – GENERAL
1.01 SECTION INCLUDES

- A. Entities identified in this Section are defined as follows:
- Company: Arizona Department of Environmental Quality (ADEQ)
 - Company's Representative: Hargis + Associates, Inc. (H+A)
 - Contractor: Supplier of requested services
- B. This Section identifies the minimum requirements of work to be completed for the Miracle Mile Silver Cholla Water Supply System at 5000 North La Cholla Boulevard Tucson, Arizona.
- C. The Contractor shall provide all work complete and operable, in strict accordance with the Design Drawings and Specifications. The work shall include, but not be limited to, all materials, labor and testing, whether or not specifically mentioned, but which are necessary for complete construction of the Miracle Mile Silver Cholla Public Water Supply System per Clean Water Act Regulations.

1.02 RELEVANT SECTIONS

- A. Drawings and general provisions of the Contract, including General and Supplementary Conditions and all other Specification Sections, apply to this Section.

1.03 REFERENCED STANDARDS

- A. Not applicable.

1.04 NOTED RESTRICTIONS

- A. Not applicable.

1.05 SITE LOCATION

- A. The Miracle Mile Silver Cholla Public Water Supply System is located at 5000 North La Cholla Boulevard, Tucson, Arizona.

1.06 PROCESS DESCRIPTION – GENERAL

Groundwater the Silver Cholla well is extracted using a multi-stage centrifugal, submersible pumps and conveyed through an above-grade galvanized carbon steel pipeline to the Miracle Mile Silver Cholla Public Water Supply System. The extracted groundwater will be treated using liquid phase carbon adsorption to remove volatile organic compounds (VOCs) and conveyed to an existing pressure vessel before entering the distribution system.

1.07 SCOPE

- A. The general scope of work (SOW) for the project includes the following:
1. Demolition of existing piping as identified in the job walk. Contractor shall take steps to protect all equipment, valving, electrical, and instrumentation identified as being reused. Any equipment, valving, instrumentation damaged during demolition activities shall be replaced National Sanitation Foundation (NSF) compliant equipment at the Contractor's expense.
 2. Contractor shall be responsible for securing and packaging/palletizing all equipment, valving, and instrumentation for storage as directed by the Field Engineer.
 3. Installation of a concrete foundation in accordance with the Design Drawings.

ENGINEERING SPECIFICATION	SUMMARY OF WORK SECTION 01 11 00	Project: <u>1233</u> Revision: <u>0</u> Date: <u>11/21/18</u> Page <u>3</u> of <u>8</u>
----------------------------------	---	--

4. Installation of a new liquid phase carbon adsorbers and manifold in accordance with the Design Drawings, manufacturer's specifications, and compliant with NSF regulations for potable water systems.
 5. Supply and installation of piping, pipe supports, conduit and wiring, valving, and instrumentation in accordance with the Design Drawings and manufacturer's specifications. Contractor shall be responsible for **all** electrical and control terminations to equipment, instrumentation, and control panels.
 6. Provide all project submittals (i.e. pre-field checklist, daily health and safety tailgate, etc., as applicable).
 7. Procurement and installation of all materials not specifically identified as being provided by the Company.
 8. Installation and termination of **all** equipment, materials, instrumentation, etc. provided by the Company.
 9. Supply and installation of modified pump motor controls: including instrumentation, relays, panel components, wiring and conduit for low flow switch, relief line flow switch and high pressure switch that shut down the well pump.
 10. Contractor shall provide personnel for functional and mechanical completion and testing (leak) at construction completion.
 11. All work to take place in accordance with Arizona Administrative Code Title 18, Chapter 5 and Clean Water Act regulations.
- B. Perform Work under fixed cost contract with the Company Representative in accordance with Conditions of Contract.
- 1.08 DIVISION OF WORK
- A. Design Drawings
1. The Design Drawings provided are intended to represent the minimum requirements for construction of the Miracle Mile Silver Cholla Public Water Supply System. The omission of any essential provision shall not be interpreted to relieve the Contractor of any duty or obligation necessary for the complete, reliable, working installation of this facility or for the work to be completed in a workman-like manner.
 2. Applicable Design Drawings provided identify utility crossings and other features identified. Although reasonable efforts have been made to ensure the accuracy and completeness of these drawings, it shall be the Contractor's responsibility to verify the location, depth, and number of utility crossings and other below-grade obstructions. The Contractor shall repair or replace any structures, including pipelines and cables, damaged by the Contractor or any of the Contractor's subcontractors at no expense to the Company.
 3. In case of conflicts within the Design Drawings the more restrictive shall apply. The Contractor shall notify the Company's Representative of the discrepancy and the Company's Representative shall determine which requirement is most restrictive.
- B. The following will be provided by the Company, Company's Representative, or Others:
1. Access to the Site.
 2. Design Drawings and specifications for the Miracle Mile Silver Cholla Public Water Supply System required for construction.
 3. An area for the Contractor's use during construction. The area may be used for temporary field office trailers, sanitary facilities, storage of materials and

ENGINEERING SPECIFICATION	SUMMARY OF WORK SECTION 01 11 00	Project: <u>1233</u> Revision: <u>0</u> Date: <u>11/21/18</u> Page <u>4</u> of <u>8</u>
----------------------------------	---	---

equipment, and staging of construction materials and/or debris. Electrical power and potable water connections will be provided by the Company.

4. On-site field representation and observation of the work performed by the Contractor. Company inspection and approval of any work shall in no way relieve the Contractor of the responsibility of meeting all federal, state, or local requirements.
 5. At the Company's discretion, confirmatory testing or inspection of compaction, concrete strength, or other work shall be performed. Confirmatory testing shall in no way relieve the Contractor of the responsibility of meeting all federal, state, or local requirements.
- C. The Contractor shall furnish all labor and materials (except for services, materials and/or equipment to be furnished by Others as specifically referred to in the Contract Documents), and perform all work required for the complete and satisfactory construction of the Miracle Mile Silver Cholla Public Water Supply System which includes, but is not limited to, the following:
1. Performing all work in accordance with the requirements described herein, including the Design Drawings and all applicable federal, state, and local laws, rules, and regulations.
 2. Furnishing all personnel required to carry out the Contractor's obligations described herein. Personnel to be provided by the Contractor include, but are not necessarily limited to, the following: purchasing personnel, expeditors, inspectors, project managers, superintendents, foreman, and skilled and unskilled labor.
 3. Transport, disposal and management of excess soil in accordance with Pima County regulations.
 4. Providing all construction equipment, materials, tools, vehicles, and expendables not specifically listed as being furnished by the Company that are required to execute the work described herein. Major items to be provided by the Contractor include, but are not limited to, the following:
 - a. All NSF 61 compliant pipe and pipe fittings, valving, bolting, gasketing, and instrumentation as identified in the Design Drawings.
 - b. All pipe and equipment supports in accordance with applicable Design Drawings
 - c. All electrical materials as needed, including all conduit, conduit fittings, conductor, Powerstrut, clamps, hangers, cadwelds, ground rods, grounds wells, liquidtight, bushings, receptacles, light fixtures, light switches, tape, and other hardware items.
 - d. All electrical control modification equipment including: pressure and flow switches, control relays, control wiring, fuses, fuse blocks, control power transforms and ancillary components.
 - e. All concrete, sand, gravel, fill material, slurry and cement.
 - f. All welding rods, Teflon tape, cutting oils, grinding disks, sandpaper, wire brushes, and expendables required for piping.
 - g. All replacement landscaping (if necessary).
 - h. Establish temporary utilities for use during construction.
 - i. Installation and maintenance of Best Management Practices (BMPs) in accordance with the Design Drawings and/or the Pima County storm water regulations.

ENGINEERING SPECIFICATION	SUMMARY OF WORK SECTION 01 11 00	Project: <u>1233</u> Revision: <u>0</u> Date: <u>11/21/18</u> Page <u>5</u> of <u>8</u>
----------------------------------	---	--

- j. Dust control and mitigation in accordance with Pima County rules and regulations.
 - k. All necessary construction permits not provided by the Company and arrange for all required inspections associated with the work described below.
 - l. Transport, disposal and management of excess soils in accordance with the Pima County storm water regulations.
 - m. Mobilization and demobilization of temporary utilities, contractor field office, and equipment laydown areas.
 - n. Trash storage and removal, sanitation facilities, and street sweeping. Provide temporary trash bins for the disposal of municipal trash, general construction debris, waste asphalt, waste concrete, etc.
 - o. All mechanical components as shown in Design Drawings (pipe, pipe supports, gauges, sample ports, check valves, globe valves, butterfly valves, ball valves, pressure control valves, etc.).
 - p. All electrical and instrumentation components as shown on Design Drawings (conduit, flow/pressure transmitters, wiring, etc.).
 - q. Housekeeping of construction work areas.
 - r. All NSF 61 compliant temporary gauges, fittings, hoses, valves, pumps, compressors, test media, relief devices, and leak inspection materials required for leak testing.
 - s. All temporary equipment for testing of electrical and control wiring.
 - t. All NSF 61 compliant replacement materials, whether originally provided by the Company, the Contractor, or Others, that have been damaged, lost, or used to repair defects in the work performed by the Contractor.
 - u. All health and safety equipment.
 - v. All temporary and permanent fencing, barriers, and warning signs required by federal, state, or local laws, rules, or regulations.
 - w. All casing materials required for road crossings, if applicable.
 - x. All temporary facilities including racks, bins, shelving, containers, sheds, pallets, tarpaulins, and visqueen, required for temporary storage of all materials, equipment provided by the Company, Contractor, and Others, temporary office trailers and facilities, and sanitation facilities.
 - y. All survey equipment and materials including transits, chains, stakes, marking paint, and flagging as needed to identify construction features.
5. Contact, coordinate, and comply with all federal, state, and local inspections for construction of the Miracle Mile Silver Cholla Public Water Supply System as required.
 6. Provide temporary electrical service for construction equipment, if applicable.
 7. Maintain a safe and clean working environment. The Company's housekeeping expectations will be high, especially at the soil/equipment lay-down areas and within the road construction zones. At any time, the Company will have the authority to require the Contractor to improve the safety and cleanliness of the work areas. Should the Contractor habitually be negligent in this responsibility, the Company may obtain safety equipment/services, as necessary, and deduct the amount of such services from the Contractor's subsequent invoice or final payment.
 8. Perform final cleanup of the Site in accordance with the requirements of the Company.

ENGINEERING SPECIFICATION	SUMMARY OF WORK SECTION 01 11 00	Project: <u>1233</u> Revision: <u>0</u> Date: <u>11/21/18</u> Page <u>6</u> of <u>8</u>
----------------------------------	---	--

9. Store and handle all equipment and materials provided by the Company, Contractor, or others.
 10. Connect and transport all water used during construction, including leak testing.
 11. Execute changes in work only after obtaining an approved Field Order, Change Order, or Work Change Directive.
 12. Coordinate the work of all subcontractors and inspectors.
 13. Notify all subcontractors of the requirements set forth herein. The Contractor shall be on Site if any subcontractors are doing work.
 14. Ensure no foreign matter enters the distribution system and coliform and E. Coli are not present in the distribution system after construction.
- D. Items noted NIC (Not in Contract);
1. Not applicable

1.09 DESCRIPTION OF WORK

The following description of work has been prepared to summarize and clarify work to be performed by the Contractor. The description shall not be construed to limit the SOW otherwise detailed in the Contract Documents.

- A. **Miracle Mile Silver Cholla Public Water Supply System**
1. **Civil Work and Site Preparation**
 - a. The Design Drawings show a conceptual pipeline alignment only. It shall be the Contractor's responsibility to layout pipeline and obtain layout approval from the Field Engineer prior to the start of work.
 - b. The Contractor shall perform all grading, scarification, backfilling, compaction testing, and re-surfacing for the installation of the Miracle Mile Silver Cholla Public Water Supply System in accordance with the Design Drawings. Excess excavated materials shall be stockpiled in the designated areas identified during the job walk.
 - c. The Contractor shall provide all subbase and base materials in accordance with the Design Drawings.
 - d. The Contractor shall layout, form, and install all concrete elements in accordance with the Design Drawings.
 - e. The Contractor shall provide and install all pipe supports in accordance with Design Drawings.
 2. **Mechanical Work**
 - a. All NSF 61 compliant galvanized carbon steel pipe and pipe fittings shall be supplied and/or installed in accordance with the Design Drawings.
 - b. The Contractor shall supply, install, calibrate, and test equipment and instrumentation supplied by the Company in accordance with the requirements of the Design Drawings and manufacturer's specifications, if applicable.
 - c. The Contractor shall flush and leak-test all piping and equipment (tanks) with clean potable water chlorinated in accordance with the Clean Water Act and State of Arizona regulations. Leak testing shall be performed by hydrostatic methods at 150 percent of the maximum allowable operating pressure.
 3. **Electrical/Instrumentation Work**
 - a. The Contractor shall supply all electrical materials including, but not limited to, conduit, conduit fittings, conductor, fuses, lights, outlets, junction boxes, and pull boxes in accordance with the Design Drawings.
 - b. The Contractor shall supply electrical control panel to allow well pump shutdown in accordance with the Design Drawings. The control panel will

ENGINEERING SPECIFICATION	SUMMARY OF WORK SECTION 01 11 00	Project: <u>1233</u> Revision: <u>0</u> Date: <u>11/21/18</u> Page <u>7</u> of <u>8</u>
----------------------------------	---	--

shutdown the well pump in the event of low flow from the carbon treatment system, high pressure at the treatment system, or flow in the pressure relief line of the treatment system. The controls will be implemented with an alarm light for each alarm, and alarm reset push button.

- c. The Contractor shall install and make all electrical and control terminations for control panel supplied by the Contractor in accordance with the Design Drawings and manufacturer's instructions.
- d. The Contractor shall test and calibrate all electrical and instrumentation in accordance with the manufacturer's instructions.
- e. The Contractor shall coordinate all required electrical inspections.

1.10 PRODUCTS SUPPLIED BY THE COMPANY

- A. Company Responsibilities:
 - 1. On delivery, inspect products jointly with Contractor.
 - 2. Submit claims for transportation damage and replace damaged, defective, or deficient items.
 - 3. Arrange for manufacturers' warranties, inspections, and service.
- B. Contractor's Responsibilities:
 - 1. Arrange and pay for material and equipment delivery to Site, if required.
 - 2. Receive and unload products at Site; inspect for completeness or damage jointly with the Company and/or the Company's Representative.
 - 3. Handle, store, install, and finish products where indicated on drawings.
 - 4. Repair or replace items damaged after receipt.

1.11 CONTRACTOR'S USE OF SITE AND PREMISES

- A. Limit use of Site and premises to allow:
 - 1. Company personnel occupancy.
 - 2. Work by the Company and Others.
- B. Construction Operations: Limited to areas noted on drawings.
- C. Time Restrictions for Performing Interior and Exterior Work: Monday through Friday 0800 to 1800. Work at night will not be required.

1.12 COOPERATION WITH OTHER CONTRACTORS

- A. The Contractor shall cooperate with and conduct work activities so as not to interfere with or hinder the progress of completion of the work being performed by other contractors. In case of dispute between contractors, the Company shall be the referee and the Company's decision shall be final and binding on all. The Contractor shall, as far as possible, arrange work activities, and shall place and dispose of the materials being used so as not to interfere with the operation of the other contractors at the Site. The Contractor shall coordinate work with that of other contractors in an acceptable manner and shall perform it in the proper sequence to that of other contractors. The Contractor shall so arrange work activities to effectively cooperate with other contractors and any employees of H+A or ADEQ working in the area. No additional compensation will be allowed on account of the cooperation required.

ENGINEERING SPECIFICATION	SUMMARY OF WORK SECTION 01 11 00	Project: <u>1233</u> Revision: <u>0</u> Date: <u>11/21/18</u> Page <u>8</u> of <u>8</u>
----------------------------------	---	---

1.13 OCCUPANCY

- A. The Company will occupy the Site during the entire period of construction.
- B. Cooperate with the Company to minimize conflict, and to facilitate the Company's operations.
- C. Schedule the work to accommodate Company occupancy.

PART 2 – PRODUCTS - (NOT USED)

PART 3 – EXECUTION - (NOT USED)

END OF SECTION

ARIZONA DEPARTMENT OF ENVIRONMENTAL QUALITY

WATER QUALITY ASSURANCE REVOLVING FUND

EMERGENCY RESPONSE ACTION

5000 N. LA CHOLLA BLVD, TUCSON, AZ 85705

SILVER CHOLLA PUBLIC WATER SUPPLY SYSTEM



SITE VICINITY MAP

DRAWING INDEX				
DRAWING TYPE	DRAWING NUMBER	DRAWING TITLE	CAD FILE NO.	REV
GENERAL	G-1	TITLE SHEET AND DRAWING INDEX	640-0209.DWG	0
	G-2	GENERAL NOTES	640-0210.DWG	0
	G-3	ELECTRICAL SYMBOLS AND LEGENDS	610-0144.DWG	0
CIVIL	C-1	SITE PLAN	550-1193.DWG	0
	C-2	FOUNDATION PLAN	585-1194.DWG	0
	C-3	CIVIL DETAILS	550-1195.DWG	0
ELECTRICAL	E-1	ELECTRICAL ONE-LINE DRAWING	521-0176.DWG	0
PROCESS	P-1	PROCESS FLOW DIAGRAM	560-0384.DWG	0
STRUCTURAL	S-1	PIPE SUPPORT DETAILS	582-0091.DWG	0

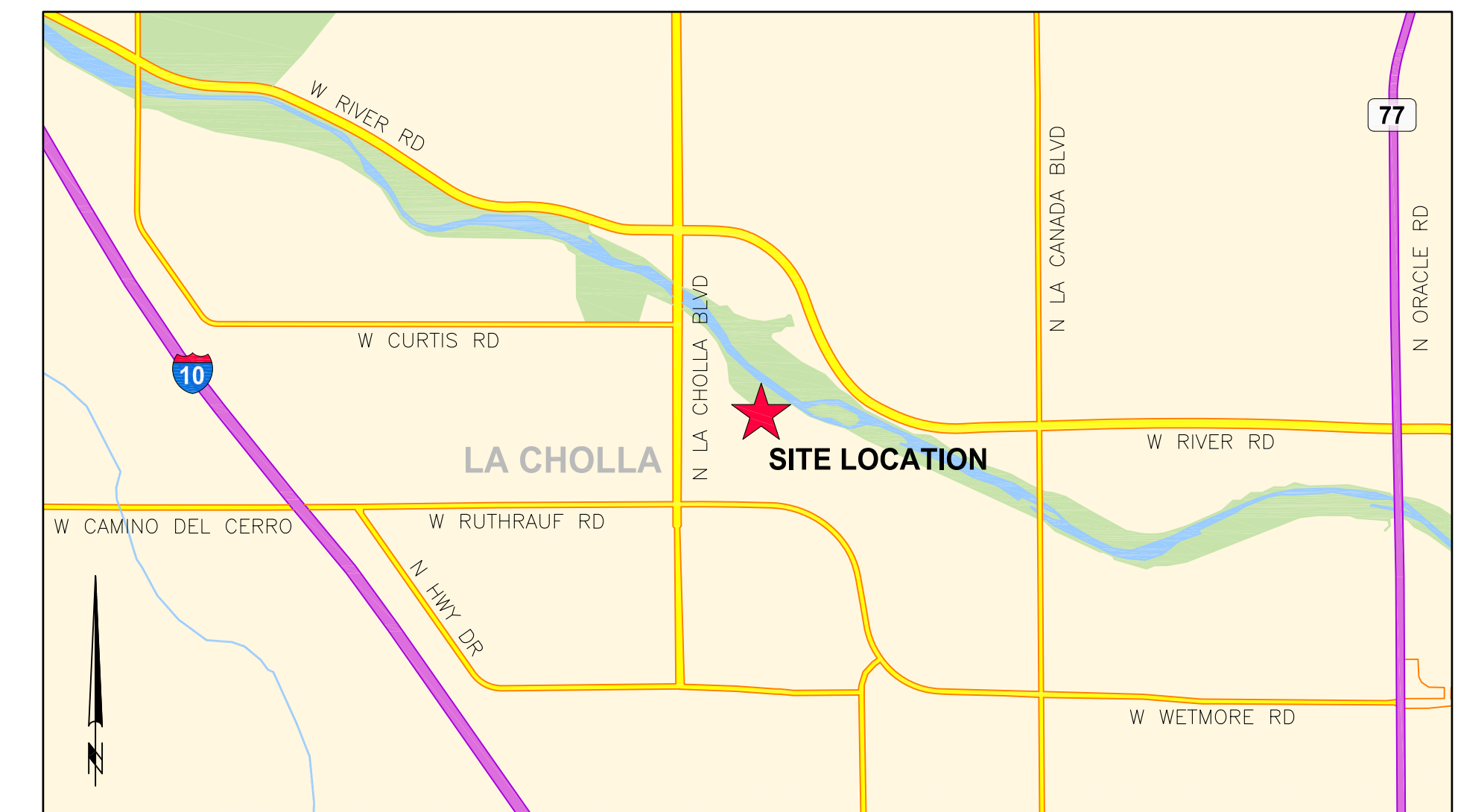

SITE AREA

REV	ISSUE	CHK'D	PW	DE	DATE

HARGIS + ASSOCIATES, INC.
 9171 TOWN CENTRE DRIVE, SUITE 375 TEL (858) 455-6500
 SAN DIEGO, CA 92122 FAX (858) 455-6533

ARIZONA DEPARTMENT OF ENVIRONMENTAL QUALITY
 TUCSON, ARIZONA
 SILVER CHOLLA PUBLIC WATER SUPPLY SYSTEM
 5000 N LA CHOLLA BLVD
 TUCSON, AZ 85705
 TITLE INDEX

DATE: 11/20/18
 PROJECT NO: 1233.06
 FILENAME: 640-0251
 SHEET:
G-1

Nov 20, 2018 - 3:53pm EST - I:\2018\1233-06-1233_Maps\Map\Engineering\General\640-0251.dwg

COMPONENT IDENTIFICATION

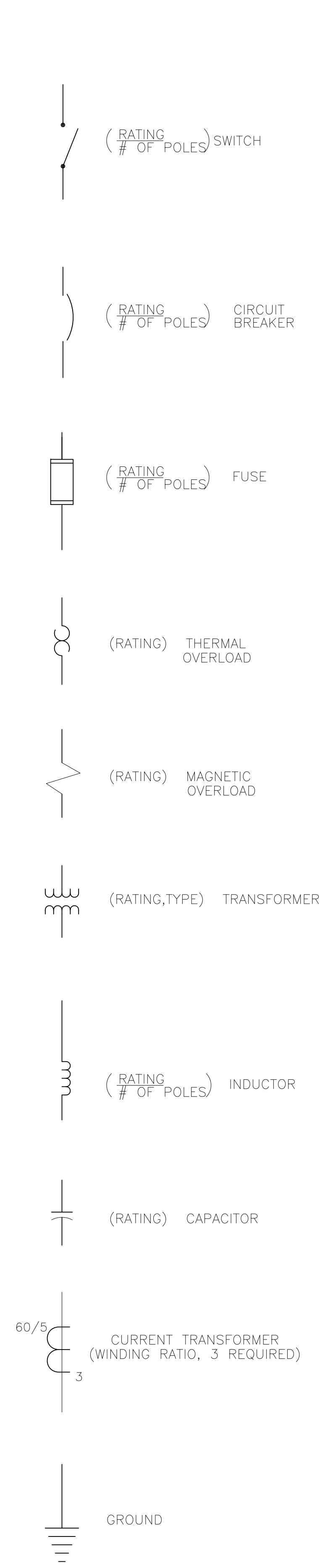

INSTRUMENT SYMBOLS

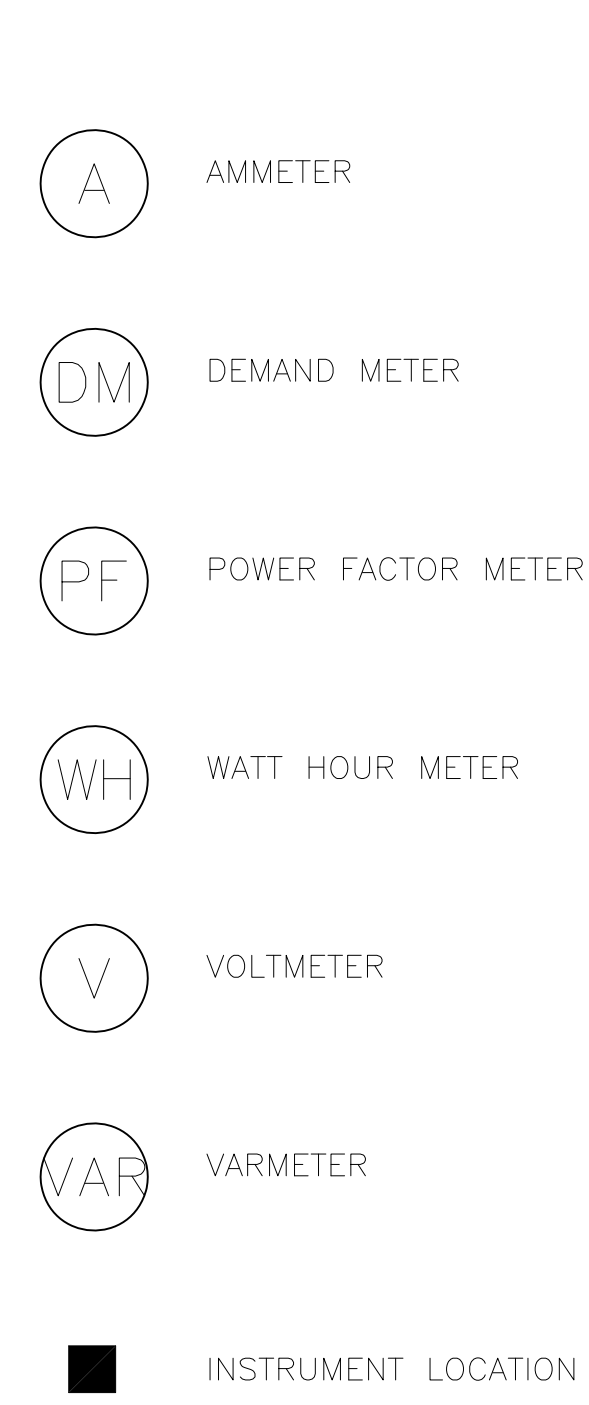

LINE SYMBOLS

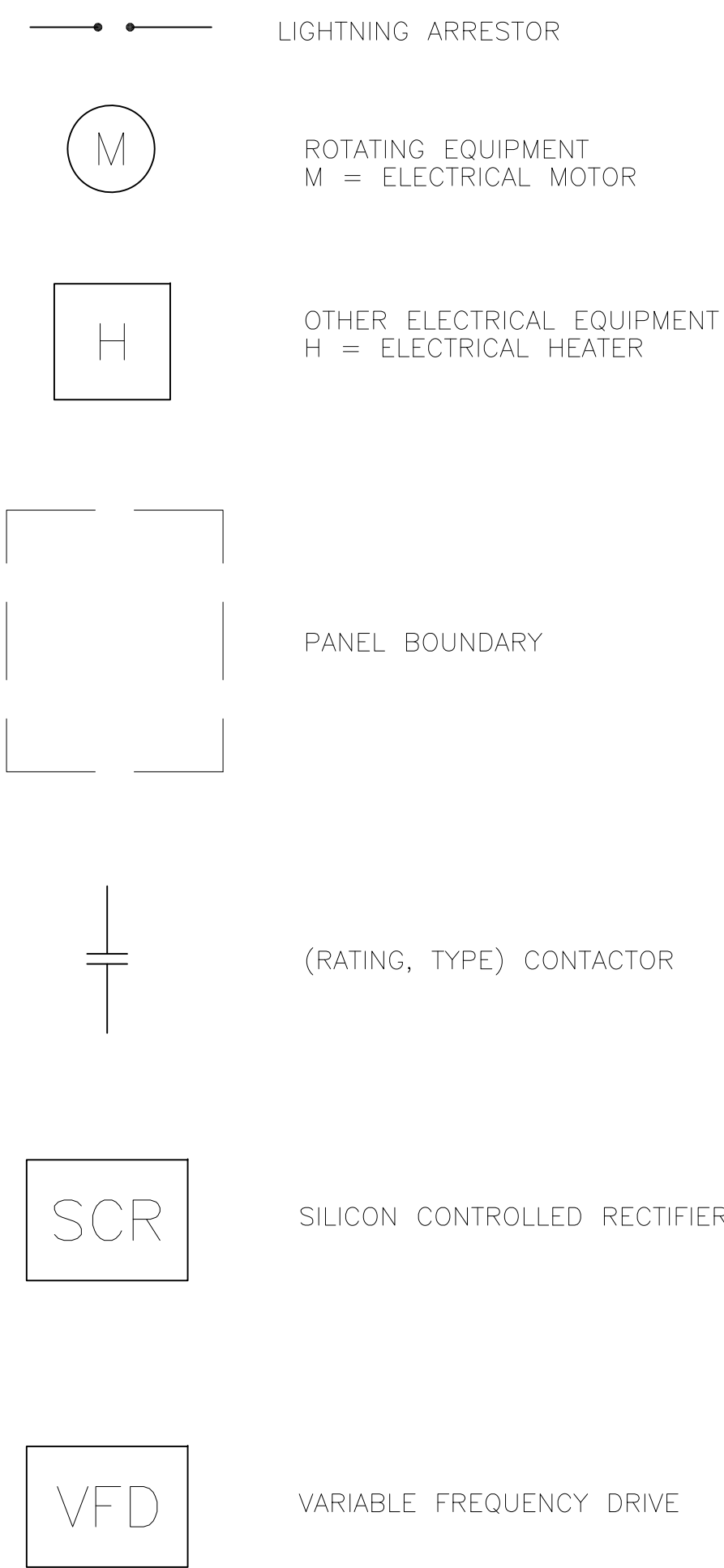
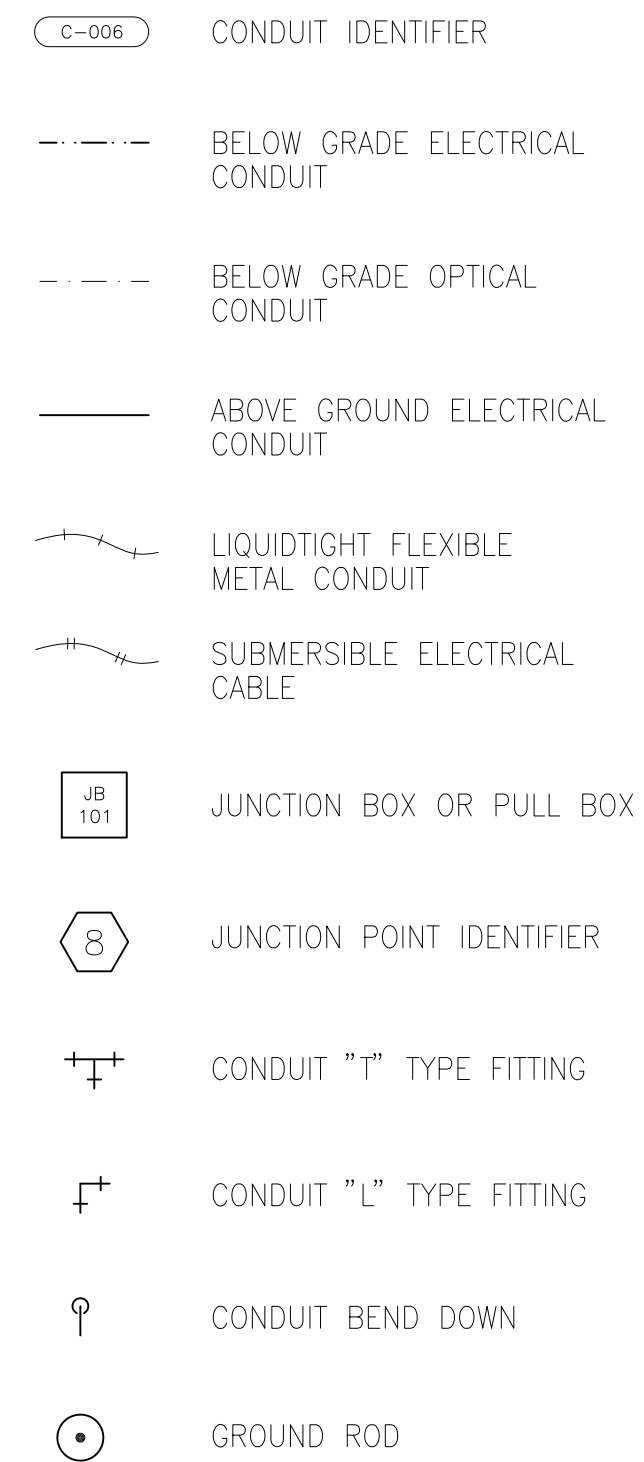

RECEPTACLE SYMBOLS

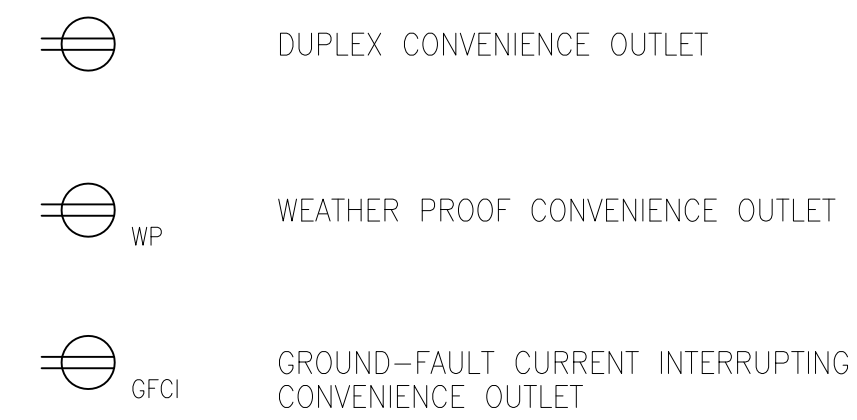

LIGHTING SYMBOLS

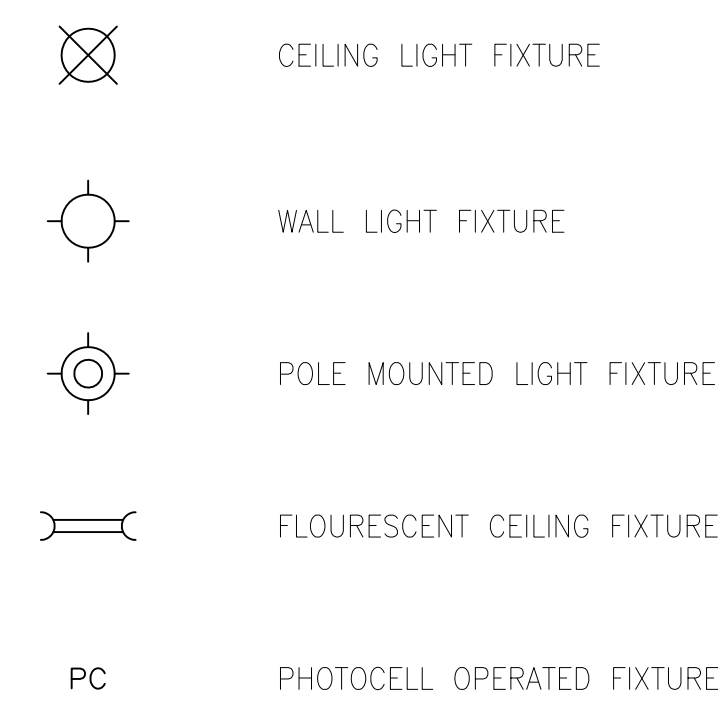

DEFINITIONS

- A = AMPERE
- AC = ALTERNATING CURRENT
- AWG = AMERICAN WIRE GAUGE
- DC = DIRECT CURRENT
- H = HENRIES
- Hp = HORSE POWER
- Hz = HERTZ
- kVA = KILOVOLT AMPERE
- KVAR = KILOVOLT AMPERE REACTIVE
- kW = KILOWATT
- KW-h = KILOWATT-HOUR
- mA = MILLIAMPERES
- mV = MILLIVOLTS
- P = POLES
- PF = POWER FACTOR
- RMS = ROOT MEAN SQUARE
- V = VOLT
- VA = VOLTAMPERE
- VAC = VOLTS ALTERNATING CURRENT
- VDC = VOLTS DIRECT CURRENT
- VAR = VOLTAMPERE REACTIVE
- W = WATT
- Z = IMPEDENCE
- BRW = BROWN
- ORG = ORANGE
- YLW = YELLOW
- GRY = GREY
- BLK = BLACK
- RED = RED
- BLE = BLUE
- WHT = WHITE
- GRN = GREEN
- GND = GROUND
- ∅ = PHASE

PANEL TAG NUMBERS



PANEL IDENTIFIER

- CP - CONTROL PANEL
- CB - CIRCUIT BREAKER PANEL
- MCC - MOTOR CONTROL CENTER
- MCB - MAIN CIRCUIT BREAKER
- MS - MAIN SWITCH

CONDUIT IDENTIFIERS



TYPE

- C - CONTROL
- P - POWER
- SP - SPARE

CIRCUIT IDENTIFIERS

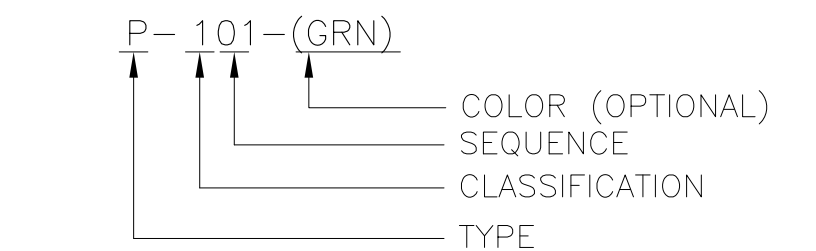

CONDUCTOR COLOR

- BRW = 480 VAC, PHASE A
- ORG = 480 VAC, PHASE B
- YLW = 480 VAC, PHASE C
- GRY = 480 VAC, NEUTRAL
- BLK = 120/240 VAC, PHASE A; UNSPECIFIED
- RED = 120/240 VAC, PHASE B
- BLE = 120/240 VAC, PHASE C
- WHT = 120/240 VAC, NEUTRAL
- GRN = GROUND

CLASSIFICATION

- 0 - UNCLASSIFIED
- 1 - 480 VOLT SERVICE
- 2 - 120/240 VOLT SERVICE
- 3 - 24 VOLT DC SERVICE

REV	ISSUE	CHK'D	DATE

HARGIS + ASSOCIATES, INC.
 9171 TOWNHE GLENVIEW DRIVE, SUITE 375
 SAN DIEGO, CA 92122
 TEL (858) 455-6500
 FAX (858) 455-6533

ARIZONA DEPARTMENT OF ENVIRONMENTAL QUALITY
 TUCSON, ARIZONA
SILVER CHOLLA PUBLIC WATER SUPPLY SYSTEM
 5000 N LA CHOLLA BLVD
 TUCSON, AZ 85705
ELECTRICAL SYMBOLS AND LEGEND

Nov 20, 2018 - 3:01pm ISS - I:\2018\1233-1233-06\Drawings\Sheet\G-3.dwg



SITE AREA

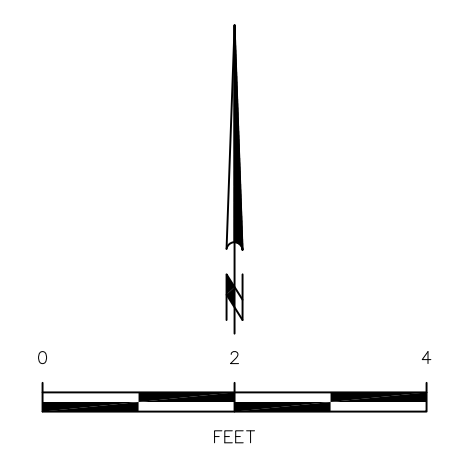
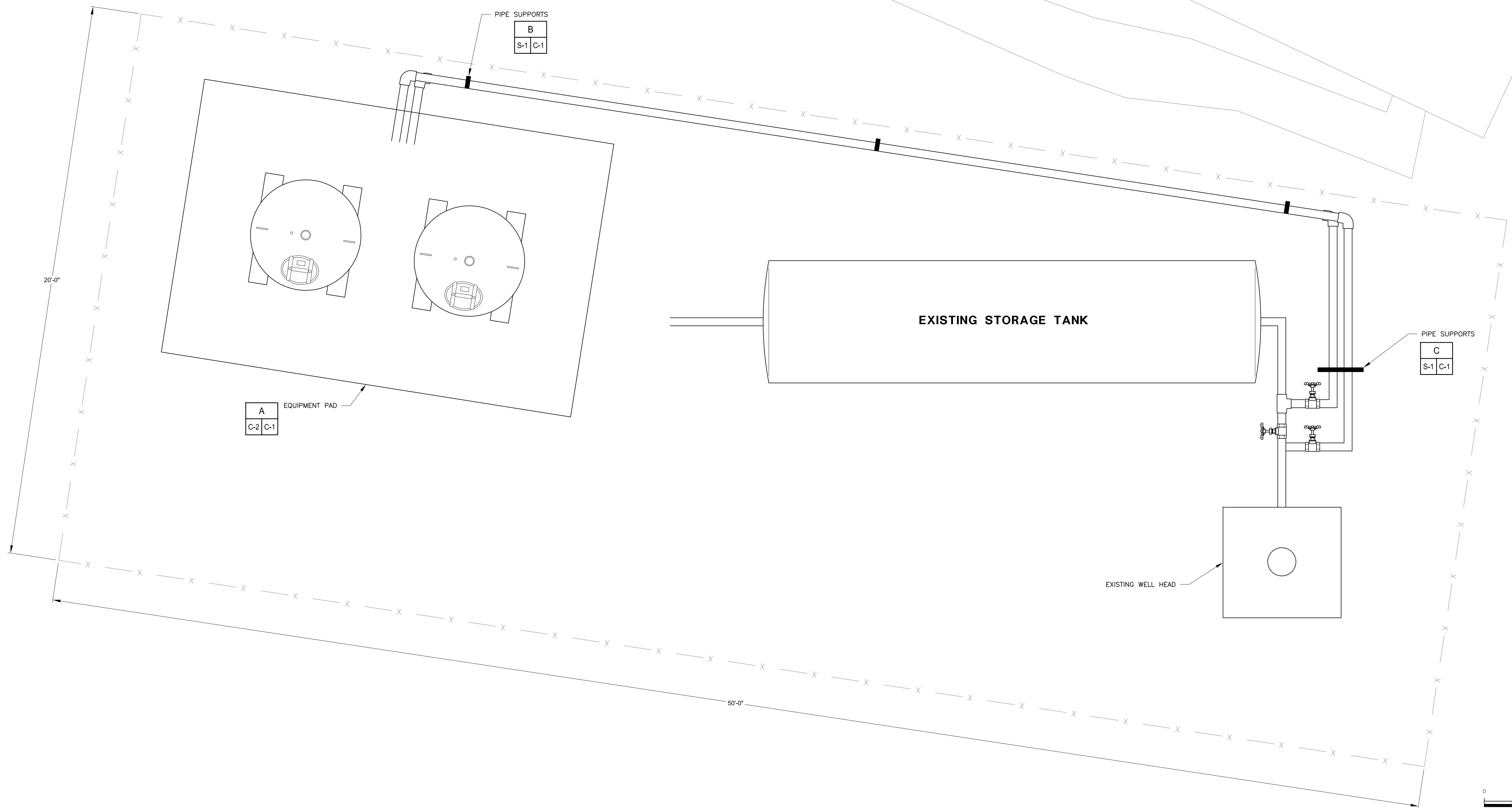

REV	ISSUE	CHK'D	PM	DE	DATE

HARGIS + ASSOCIATES, INC.
 TUCSON, ARIZONA
 9171 TOWNE CENTRE DRIVE, SUITE 375
 SAN DIEGO, CA 92122
 TEL (858) 455-6500
 FAX (858) 455-6533

ARIZONA DEPARTMENT OF ENVIRONMENTAL QUALITY
 TUCSON, ARIZONA
SILVER CHOLLA PUBLIC WATER SUPPLY SYSTEM
 5000 N LA CHOLLA BLVD
 TUCSON, AZ 85705
SITE PLAN

DATE: 11/20/18
 PROJECT NO: 1233.06
 FILENAME: 550-1193
 SHEET: **C-1**

Nov 20, 2018 - 3:35pm EST - I:\2018\1233-06\1233_Maps\Map\LogSheet\CA\550-1193.dwg

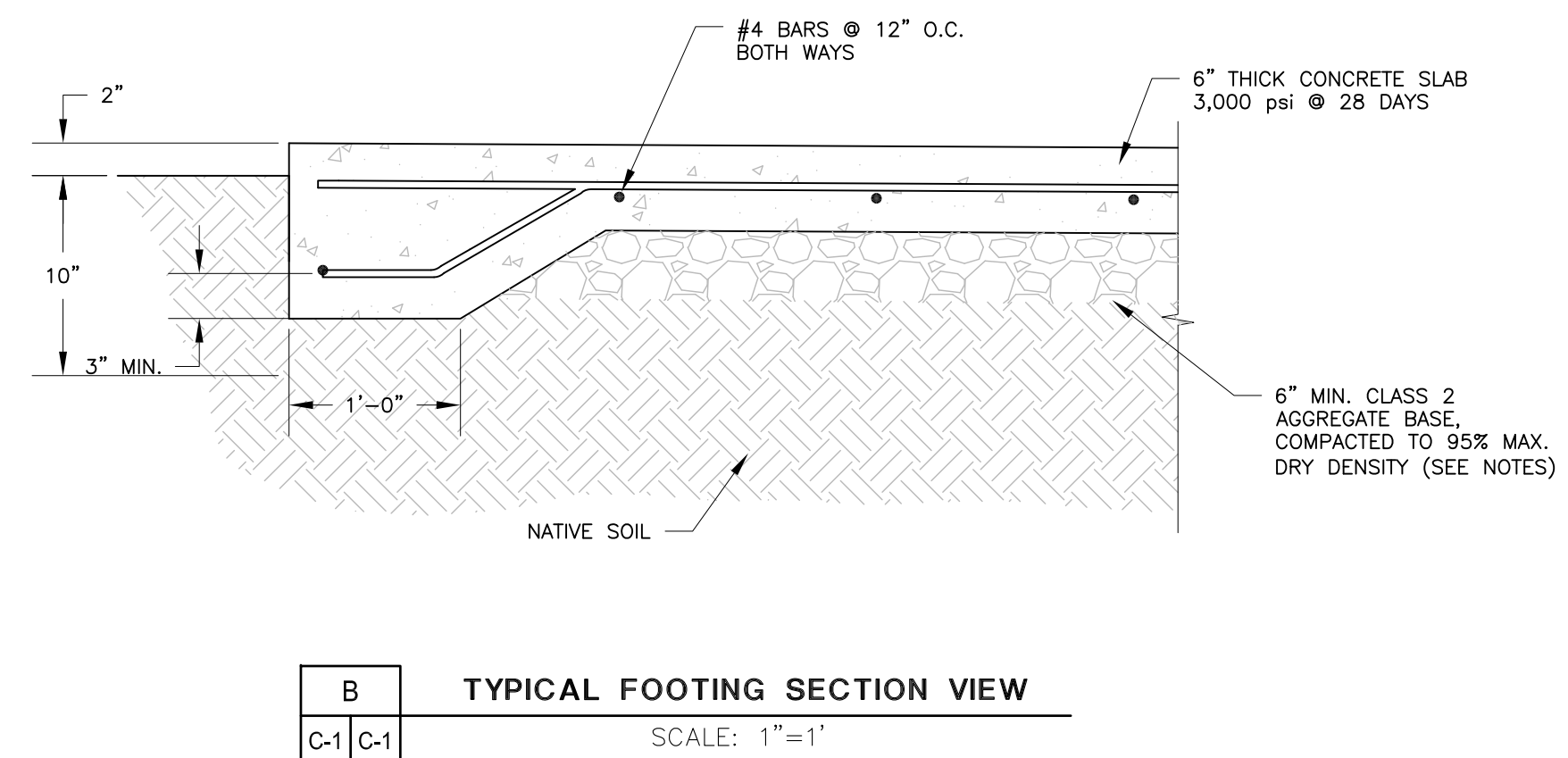
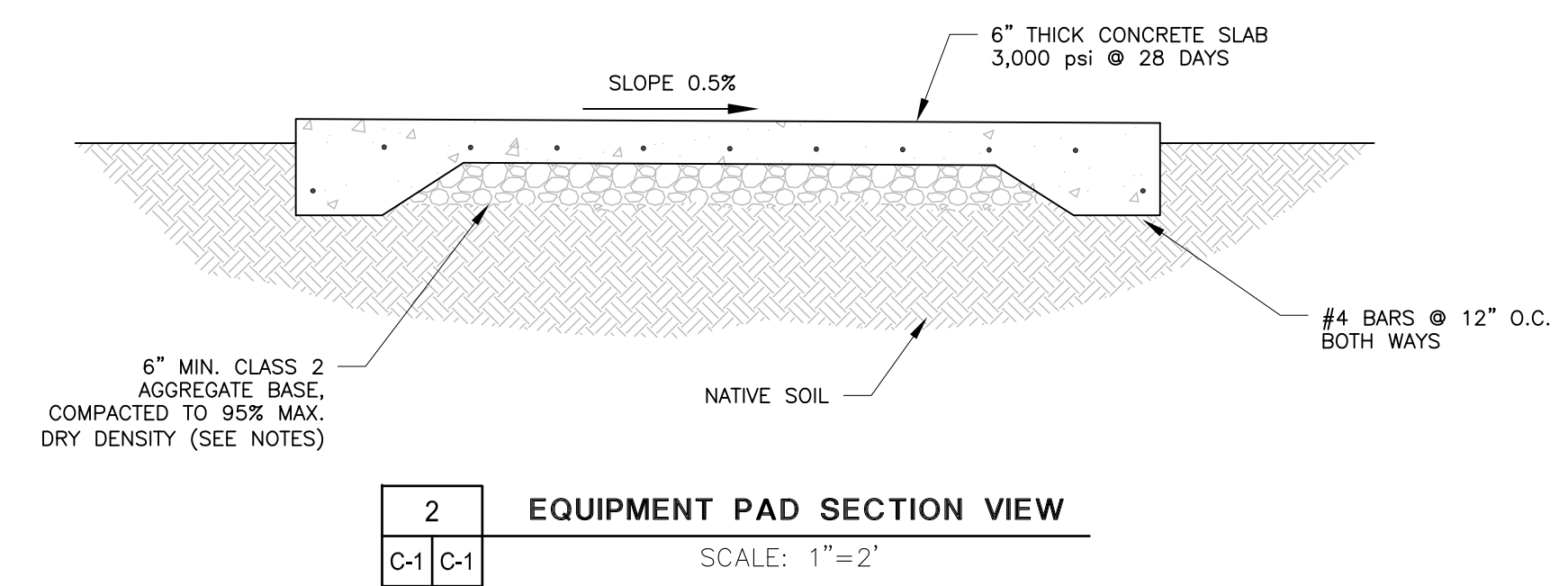
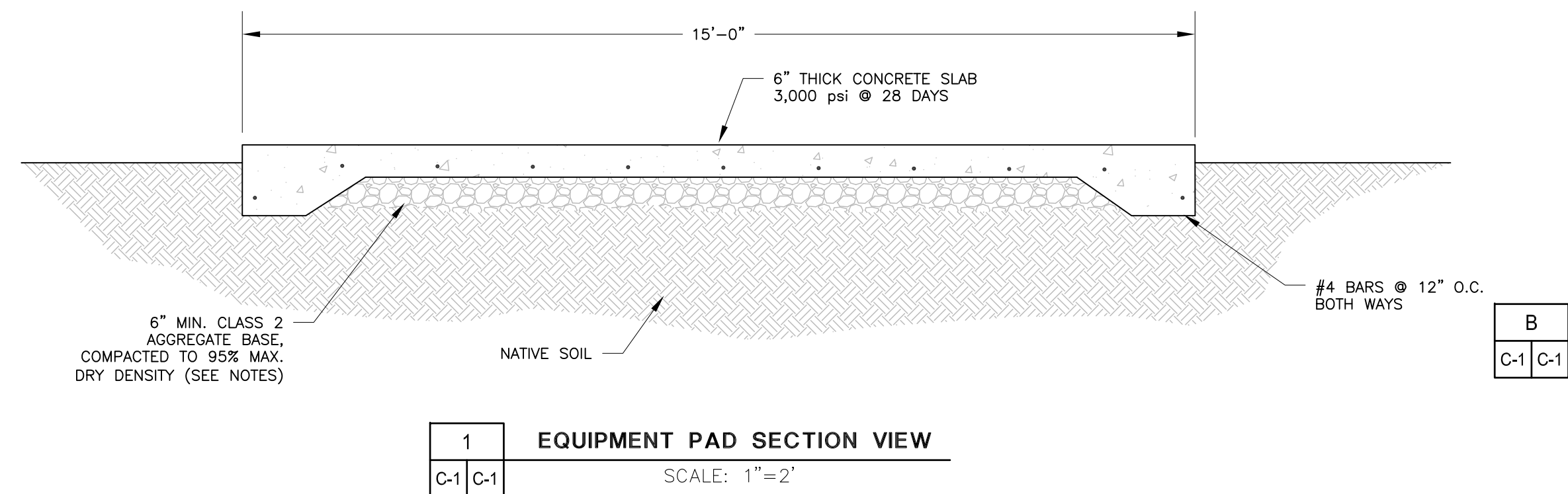
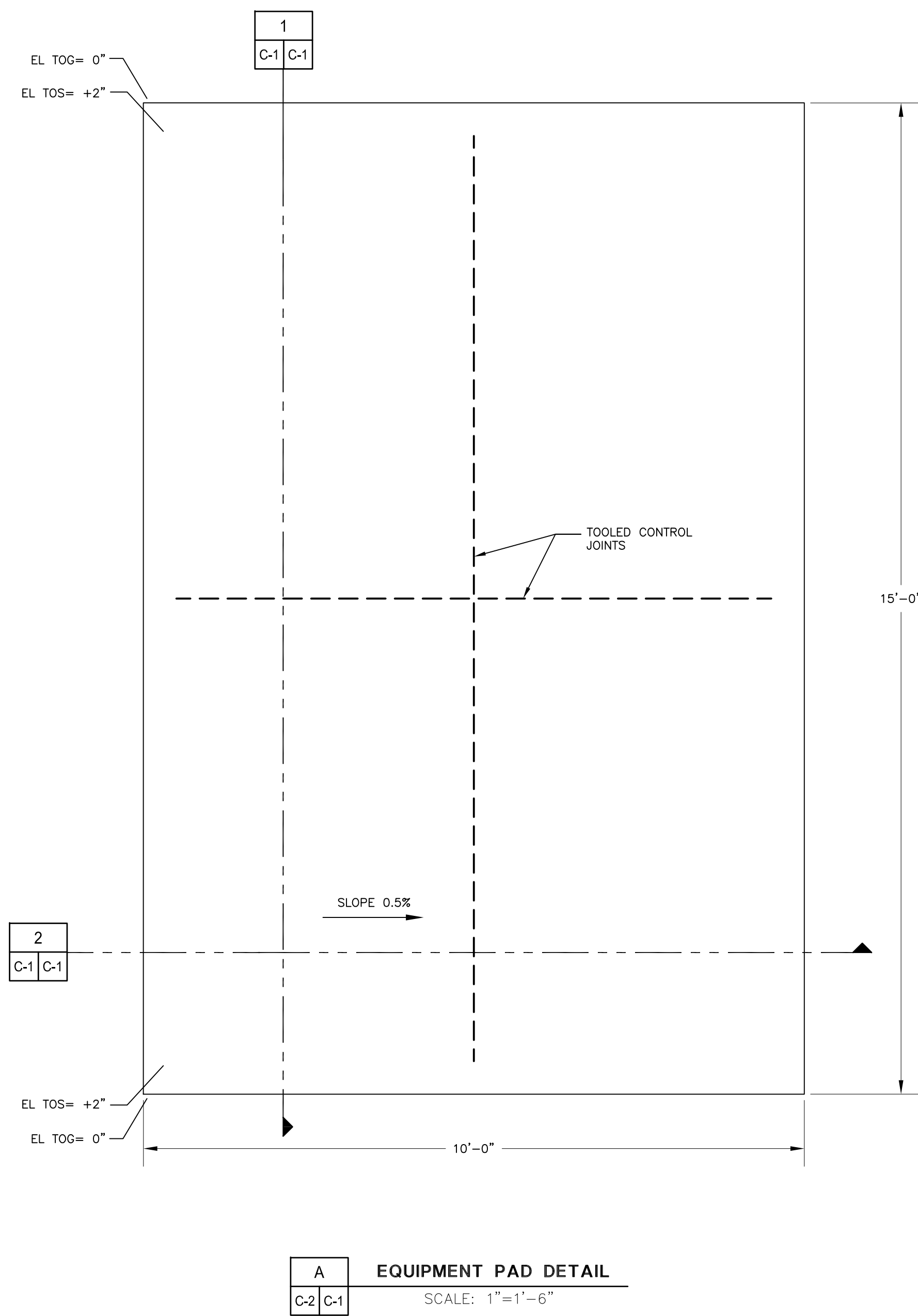

- NOTES:**
- EL TOS= ELEVATION AT TOP OF SLAB (RELATIVE)
 - EL TO G = ELEVATION AT TOP OF GRADE (RELATIVE)
 - 1. CONCRETE SHALL BE 3,000 PSI AT 28 DAYS
 - 2. TOOLED CONTROL JOINTS SHALL BE PLACED ALONG THE LENGTH AND WIDTH OF THE SLAB. REINFORCING STEEL SHALL BE CONTINUOUS THROUGH JOINTS. REINFORCEMENT BAR SHALL BE PLACED 3" MINIMUM FROM BOTTOM OF SLAB.
 - 3. MINIMUM COVER FOR REINFORCEMENT BAR AT ALL LOCATIONS IS 3".
 - 4. AGGREGATE BASE SHALL BE CLASS II AGGREGATE BASE WITH A MAXIMUM SIZE GRADATION OF 1-1/2", A MINIMUM R-VALUE OF 78 AND A MINIMUM SAND INDEX OF 22. AGGREGATE BASED SHALL BE PLACED IN A CONTINUOUS LAYER AND COMPACTED TO 95 PERCENT OF THE MAXIMUM DRY DENSITY AS DETERMINED BY ASTM D1557. MOISTURE CONTENT OF FILL SHALL BE MAINTAINED WITHIN 2 PERCENTAGE POINTS OF OPTIMUM MOISTURE CONTENT DURING COMPACTION.

REV	ISSUE	CHK'D	FW	DE	DATE

HARGIS + ASSOCIATES, INC.
TUCSON, ARIZONA
9171 TOWNHE CENTRE DRIVE, SUITE 375
SAN DIEGO, CA 92122
TEL (858) 455-6500
FAX (858) 455-6533

ARIZONA DEPARTMENT OF ENVIRONMENTAL QUALITY
TUCSON, ARIZONA
SILVER CHOLLA PUBLIC WATER SUPPLY SYSTEM
5000 N LA CHOLLA BLVD
TUCSON, AZ 85705
FOUNDATION PLAN

DATE: 11/20/18

PROJECT NO: 1233.06

FILENAME: 550-1194

SHEET: **C-2**

Nov 20, 2018 - 3:36pm EST - 1_12018\1200-1233_Monster_Water\Logos\CA\550-1194.dwg

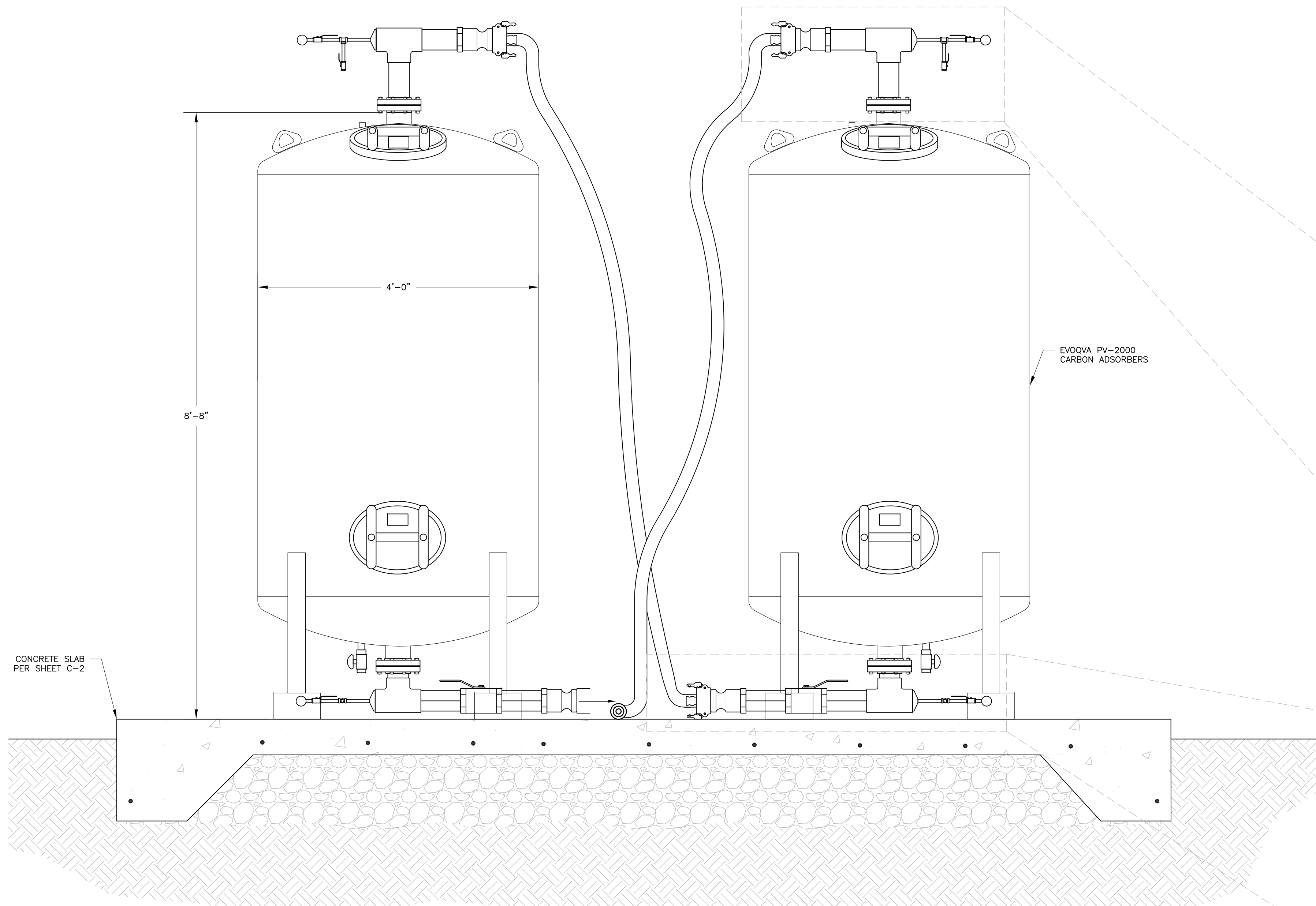

TEMPORARY TREATMENT SYSTEM CONNECTION - SIDE VIEW
SCALE: 1"=1'-0"

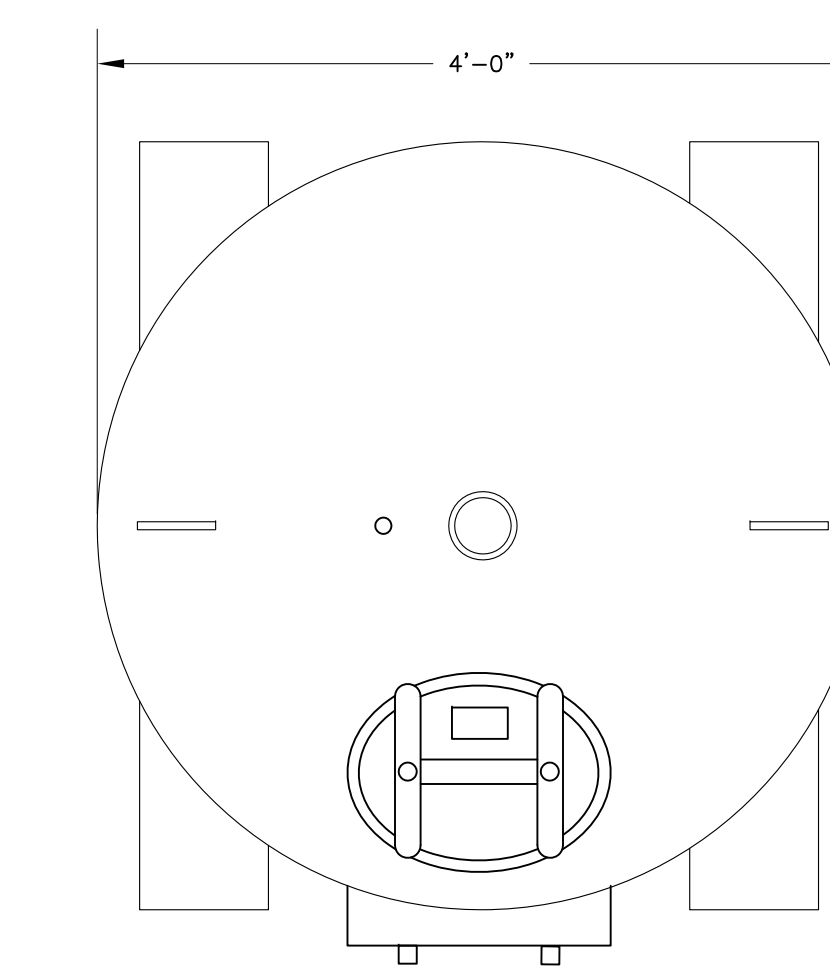

TEMPORARY TREATMENT SYSTEM CONNECTION - PLAN VIEW
SCALE: 1"=1'-0"

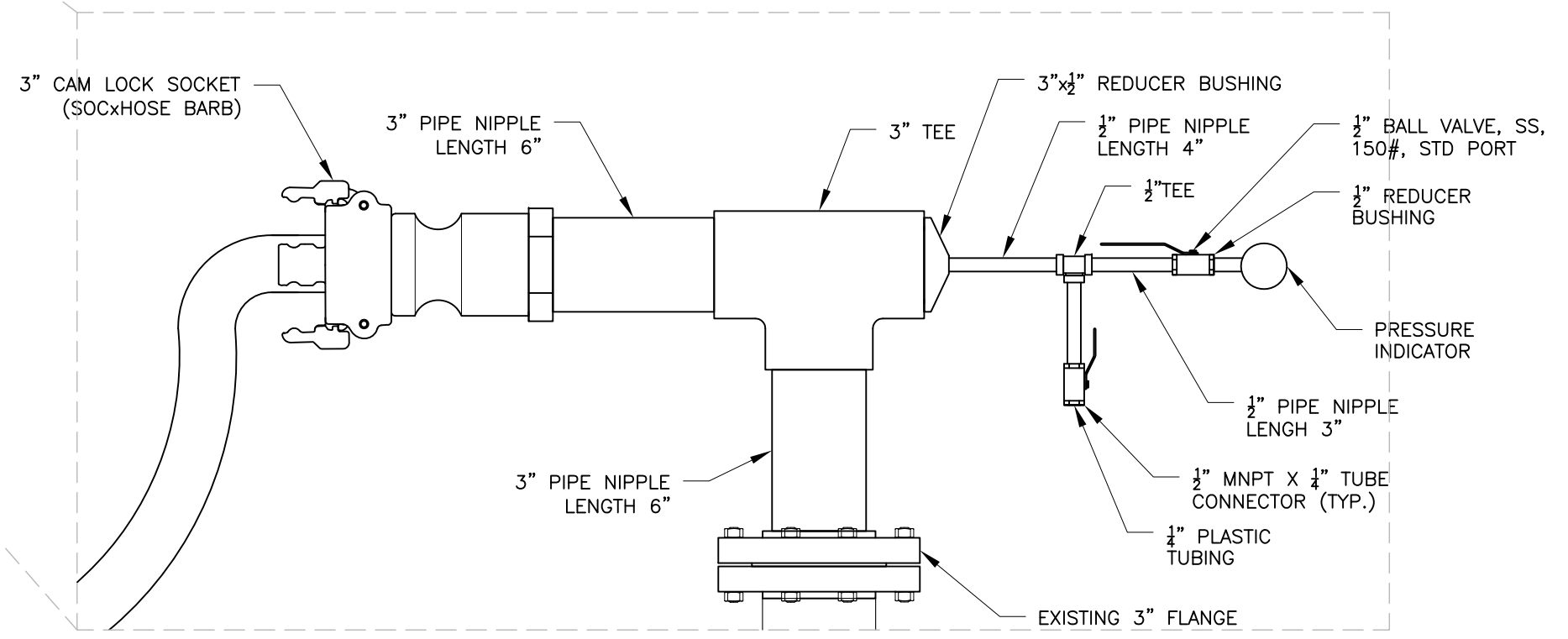

DETAIL AREA SIDE VIEW
SCALE: 1"=6"

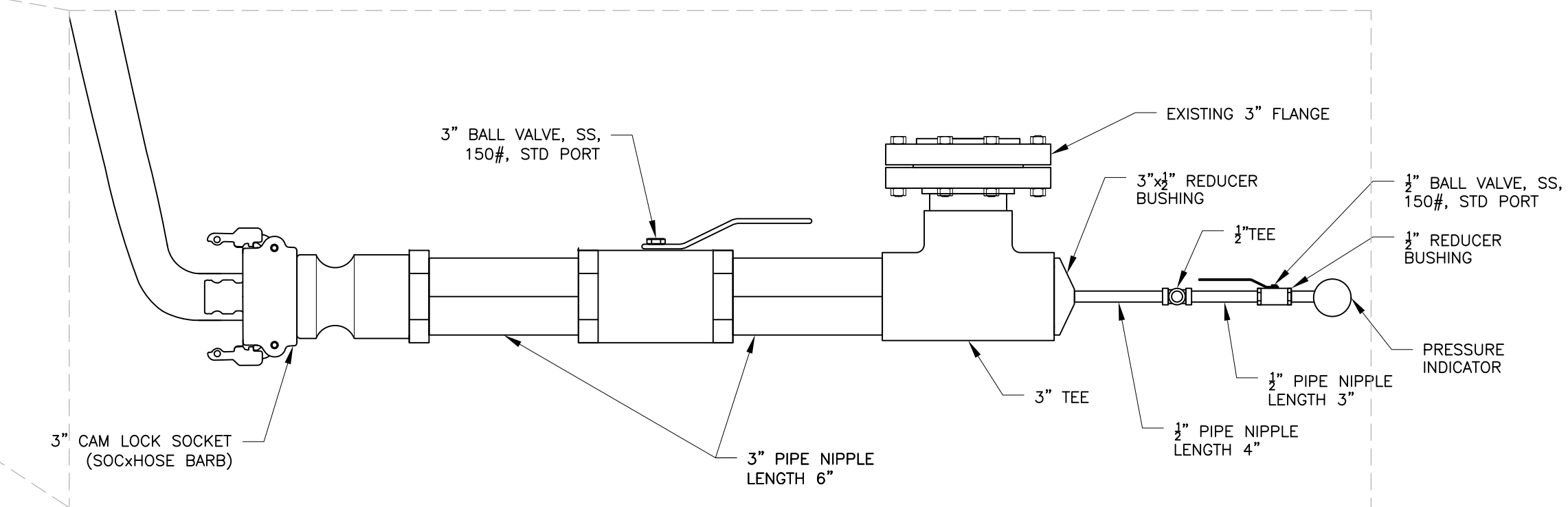

DETAIL AREA SIDE VIEW
SCALE: 1"=6"

- NOTES:**
1. ALL CONTRACTOR PIPING TO BE THREADED GALVANIZED CARBON STEEL.
 2. A 3" BALL VALVE TO BE INSTALLED AT THE INLET/OUTLET TO PAD.
 3. PI = PRESSURE INDICATOR IN PSI
 4. SP = SAMPLE PORT

REV	ISSUE	CHK'D	DATE

HARGIS + ASSOCIATES, INC.
 9171 TOWNHILL GLENVIEW DRIVE, SUITE 375
 SAN DIEGO, CA 92122
 TEL (858) 455-6500
 FAX (858) 455-6533

ARIZONA DEPARTMENT OF ENVIRONMENTAL QUALITY
 TUCSON, ARIZONA
SILVER CHOLLA PUBLIC WATER SUPPLY SYSTEM
 5000 N LA CHOLLA BLVD
 TUCSON, AZ 85705
PIPING DETAILS

DATE: 11/20/18
 PROJECT NO: 1233.06
 FILENAME: 550-1195
 SHEET: **C-3**

LOAD CALCULATION	
WELL	15 HP = 15 KVA
SUB-TOTAL	= 15 KVA
25% OF LARGEST MOTOR LOAD	= 3.75 KVA
TOTAL LOAD	= 18.75 KVA
SERVICE:	
240V, 3 ϕ 4W	
18.75 KVA / (240 x 1.732) = 45 AMPS	
100 AMP MINIMUM SERVICE REQUIRED	

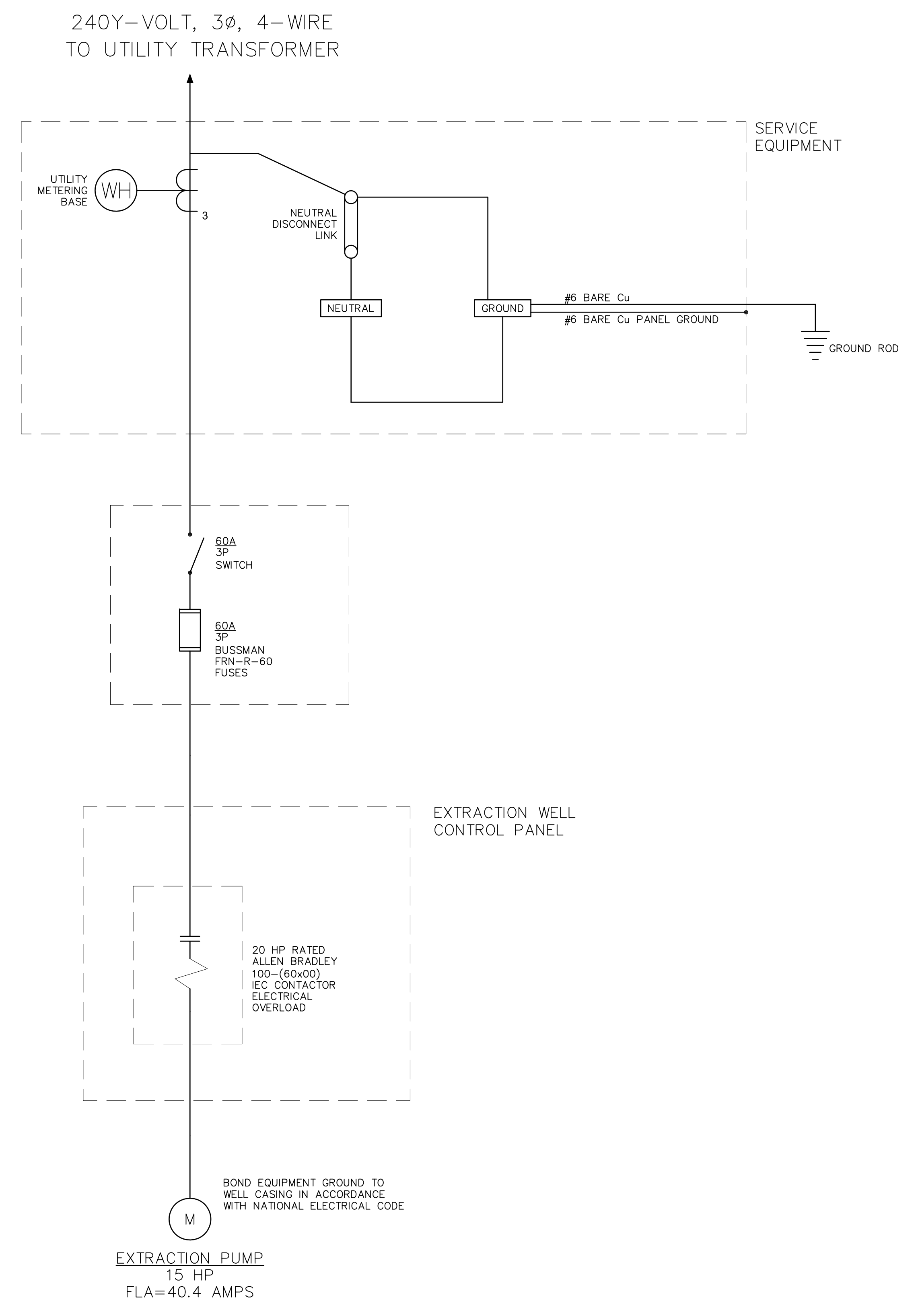

REV	ISSUE	CHK'D	DATE

HARGIS + ASSOCIATES, INC.
 TUCSON, ARIZONA
 9171 TOWNHE CENTRE DRIVE, SUITE 375
 SAN DIEGO, CA 92122
 TEL (858) 455-6500
 FAX (858) 455-6533

ARIZONA DEPARTMENT OF ENVIRONMENTAL QUALITY
 TUCSON, ARIZONA
 SILVER CHOLLA PUBLIC WATER SUPPLY SYSTEM
 5000 N LA CHOLLA BLVD
 TUCSON, AZ 85705
 ELECTRICAL ONE-LINE DIAGRAM

DATE: 11/20/18
 PROJECT NO: 1233.06
 FILENAME: 521-0176
 SHEET: **E-1**

Nov 20, 2018 - 8:02am EST - I:\2018\1233-06-1233_Motor_Mat\Logan\Drawings\Electrical\521-0176.dwg

PS-01
SILVER CHOLLA EXTRACTION PUMP

EXISTING

V-01, V-02
LIQUID PHASE CARBON ADSORBERS

MFG: EVOQUA
MODEL: PV-2000
SIZE: 4'0"ø x 8'-8"
CAP: 2,000 LBS
WEIGHT: 7,500 LBS OPERATING
DESIGN PRESSURE: 75 PSIG

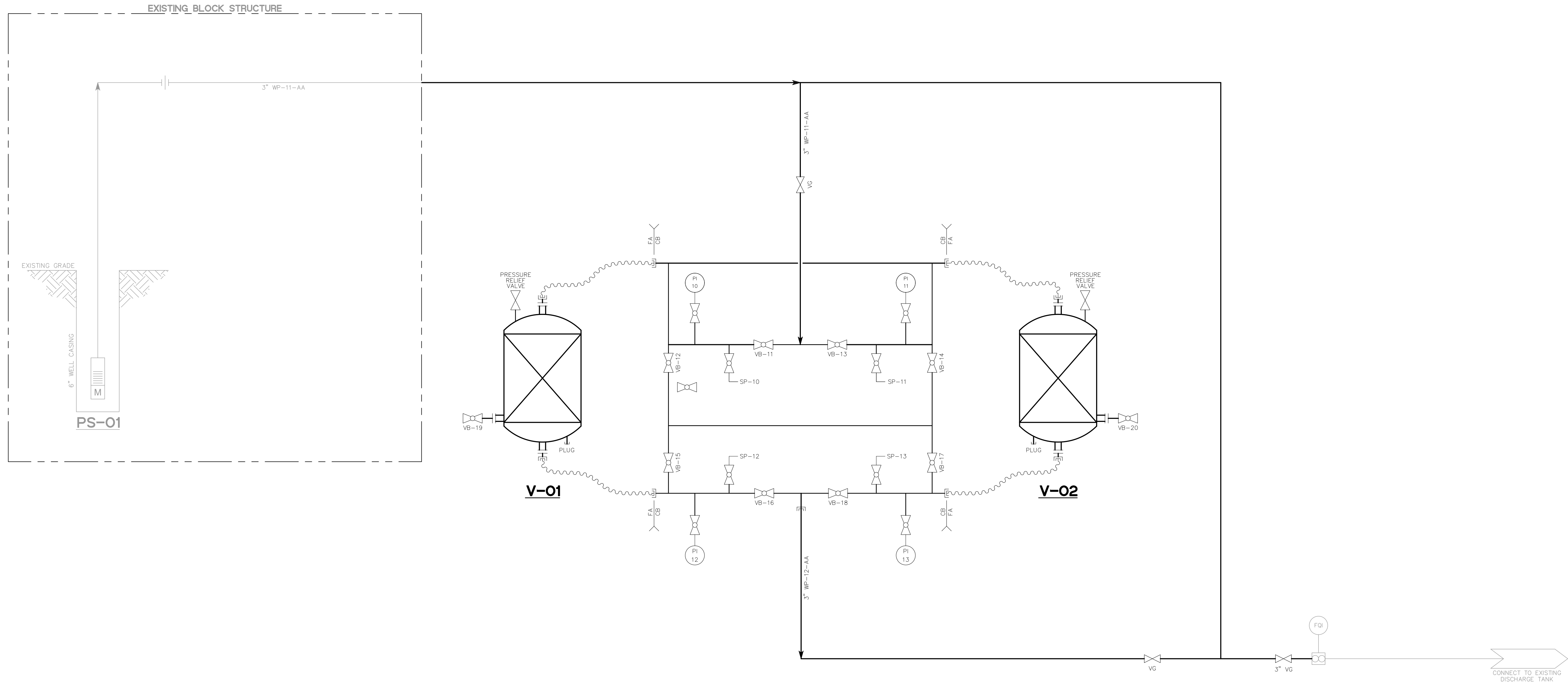

NOTES:

- ALL PIPELINES CONVEYING WATER UNDER PRESSURE SHALL BE SUBJECTED TO A HYDROSTATIC PRESSURE TEST AT A TEST PRESSURE OF 75 PSIG. THE TEST PRESSURE SHALL BE MAINTAINED FOR 2 HOURS. POTABLE WATER SHALL BE USED FOR THE TEST AND THE TESTING SHALL BE PERFORMED AFTER ALL PIPING IS INSTALLED AND PRIOR TO BEING BACKFILLED. POTABLE WATER IS AVAILABLE AT THE CHATHAM YARD. CONTRACTOR TO TRANSPORT WATER TO THE SITE. THE CONTRACTOR MUST PROVIDE NECESSARY THRUST RESTRAINTS WHEN PERFORMING HYDROSTATIC PRESSURE TESTING IN OPEN TRENCH. CONTRACTOR SHALL PROVIDE PIPE TAPS, NOZZLES AND CONNECTIONS AS NECESSARY TO PERMIT TESTING INCLUDING AIR RELIEF VALVES AT THE HIGH POINTS IN THE PIPELINE, CONNECTIONS TO DRAIN PIPELINES AFTER TESTING, ETC. PRESSURE TESTING SHALL BE PERFORMED ON ALL PIPING AT A TIME AGREED UPON AND IN THE PRESENCE OF THE ENGINEER. VALVES TO ISOLATE EQUIPMENT ARE NOT DESIGNED TO WITHSTAND THE FULL TEST PRESSURE. IF A LEAK IS DETECTED REPAIR AND RETEST SHALL BE AT CONTRACTOR'S EXPENSE. CONTRACTOR IS RESPONSIBLE FOR REMOVAL AND DISPOSAL OF WATER USED FOR TESTING.

ARIZONA DEPARTMENT OF ENVIRONMENTAL QUALITY

TUCSON, ARIZONA
SILVER CHOLLA PUBLIC WATER SUPPLY SYSTEM
5000 N LA CHOLLA BLVD
TUCSON, AZ 85705
PROCESS FLOW DIAGRAM

HARGIS + ASSOCIATES, INC.
TUCSON, ARIZONA
9171 TOWNHE CENTRE DRIVE, SUITE 375
SAN DIEGO, CA 92122
TEL (858) 455-6500
FAX (858) 455-6533

DATE: 11/20/18

PROJECT NO: 1233.06

FILENAME: 560-0384

SHEET:

P-1

REV	ISSUE	CHK'D	FW	DE	DATE

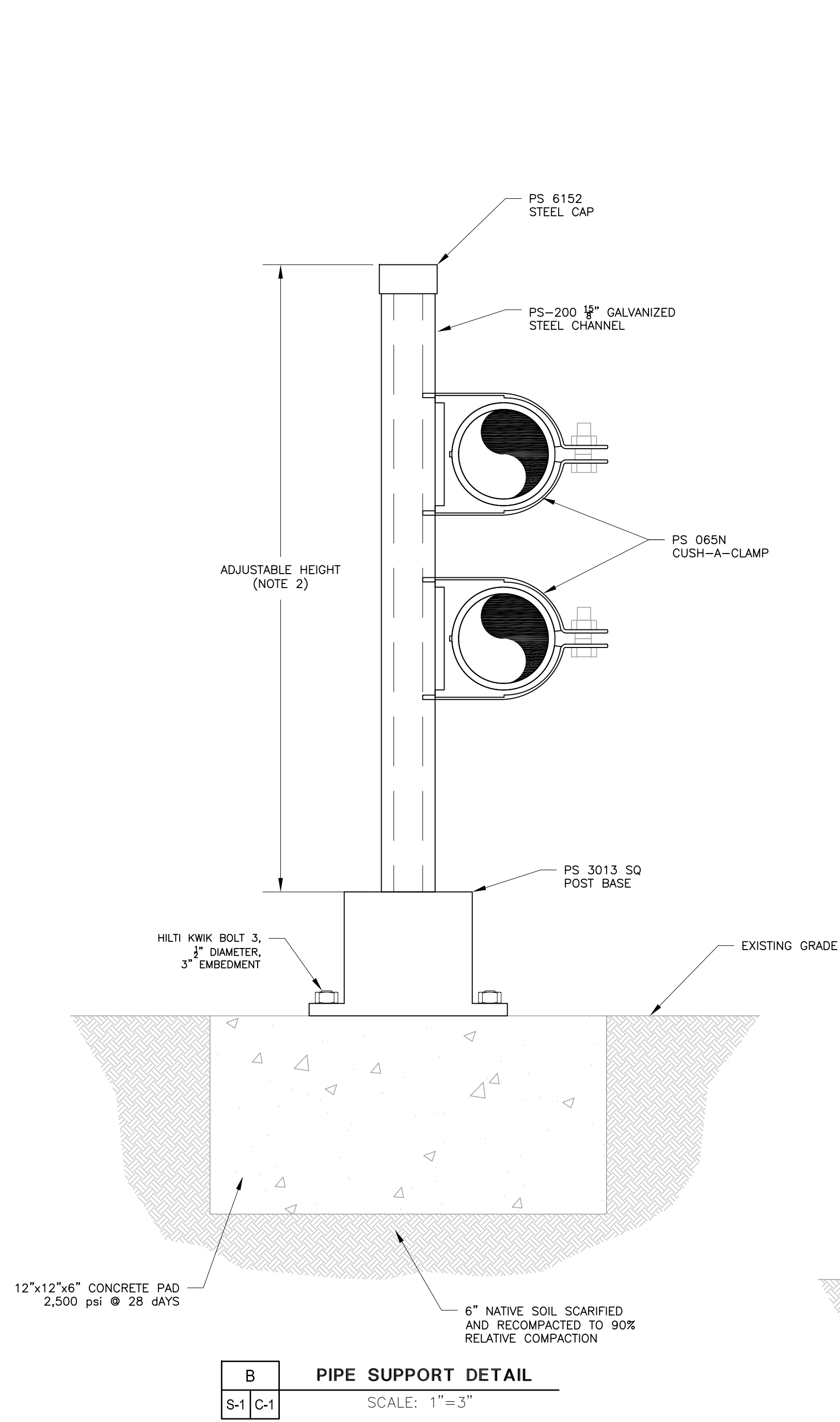

B PIPE SUPPORT DETAIL
 S-1 C-1 SCALE: 1"=3"

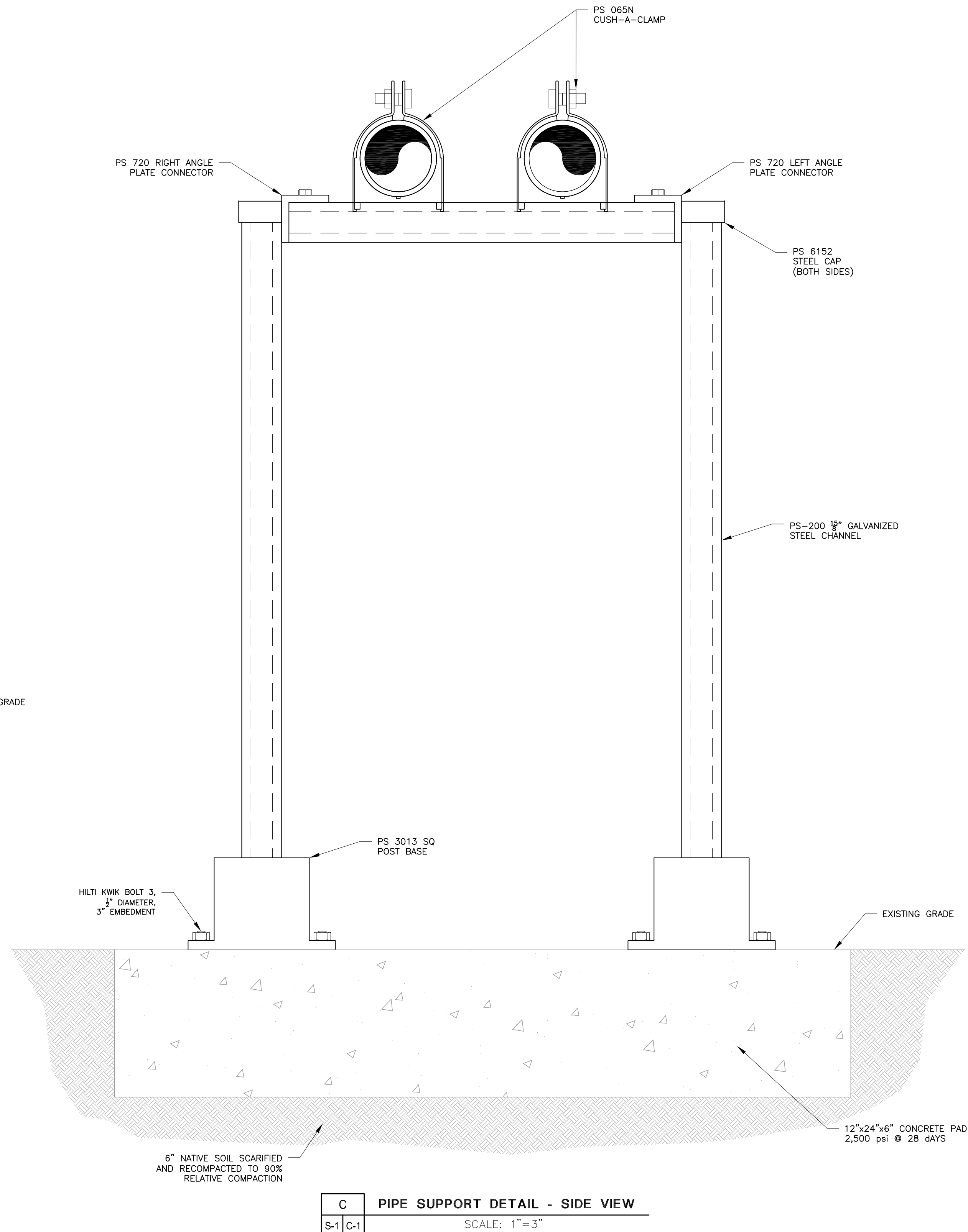

C PIPE SUPPORT DETAIL - SIDE VIEW
 S-1 C-1 SCALE: 1"=3"

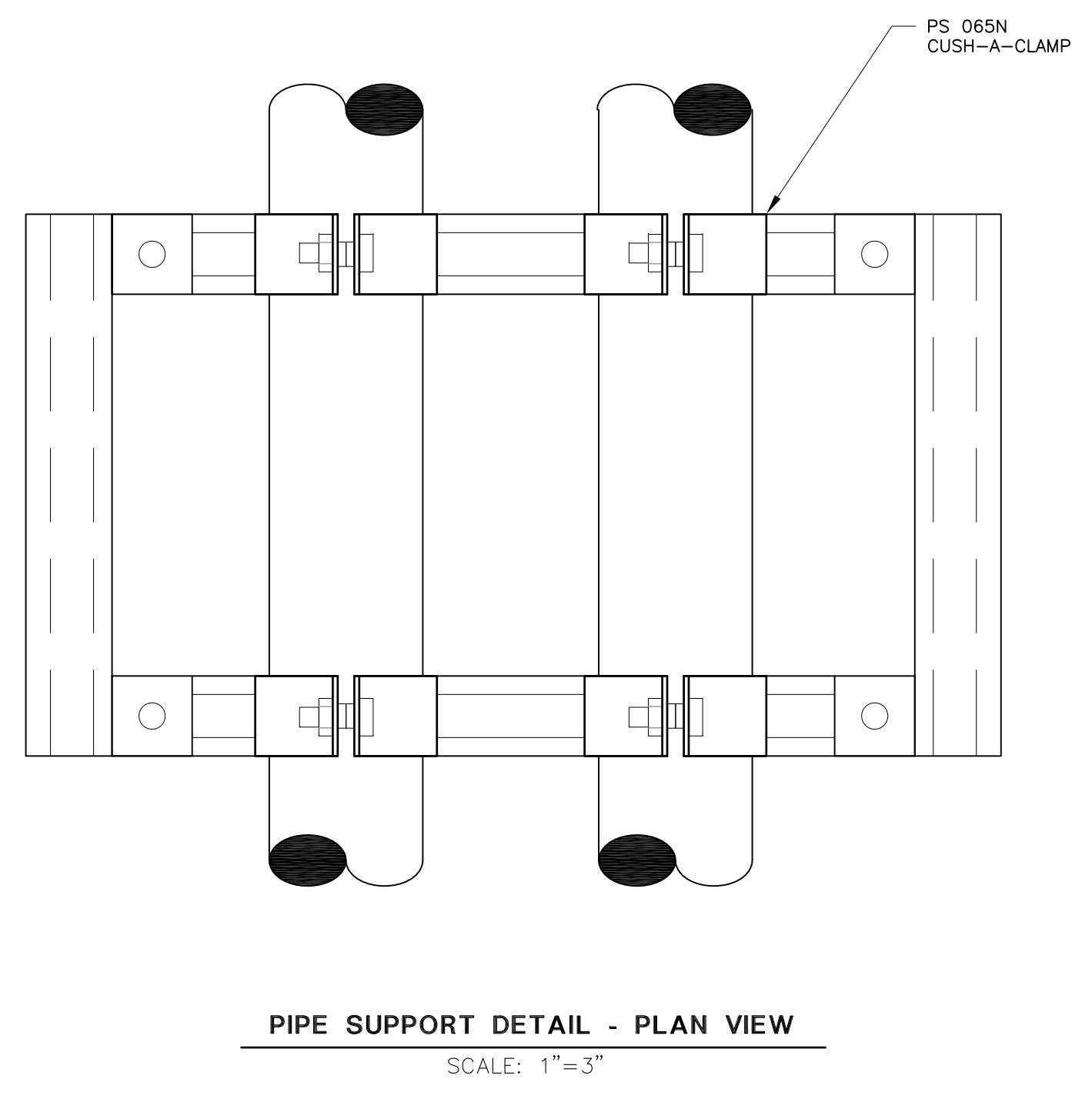

PIPE SUPPORT DETAIL - PLAN VIEW
 SCALE: 1"=3"

- NOTES:**
1. SUPPORTS SHALL BE PLACED AT A MINIMUM OF EVERY 15 FEET.
 2. PIPE SUPPORT HEIGHT SHALL BE FIELD ADJUSTED FOR GRADE CHANGES TO MAINTAIN LEVEL ELEVATION.
 3. ALL SUPPORT DETAILS SHALL BE POWER STRUT OR APPROVED EQUAL.
 4. STRUCTURAL ANCHORS SHALL BE 304 STAINLESS STEEL.

REV	ISSUE	CHK'D	DATE

HARGIS + ASSOCIATES, INC.
 9171 TOWNIE CENTRE DRIVE, SUITE 375
 SAN DIEGO, CA 92122
 TEL (858) 455-6500
 FAX (858) 455-6533

ARIZONA DEPARTMENT OF ENVIRONMENTAL QUALITY
 TUCSON, ARIZONA
SILVER CHOLLA PUBLIC WATER SUPPLY SYSTEM
 5000 N LA CHOLLA BLVD
 TUCSON, AZ 85705
PIPE SUPPORT DETAILS

DATE: 11/20/18
 PROJECT NO: 1233.06
 FILENAME: 582-0091

SHEET: **S-1**

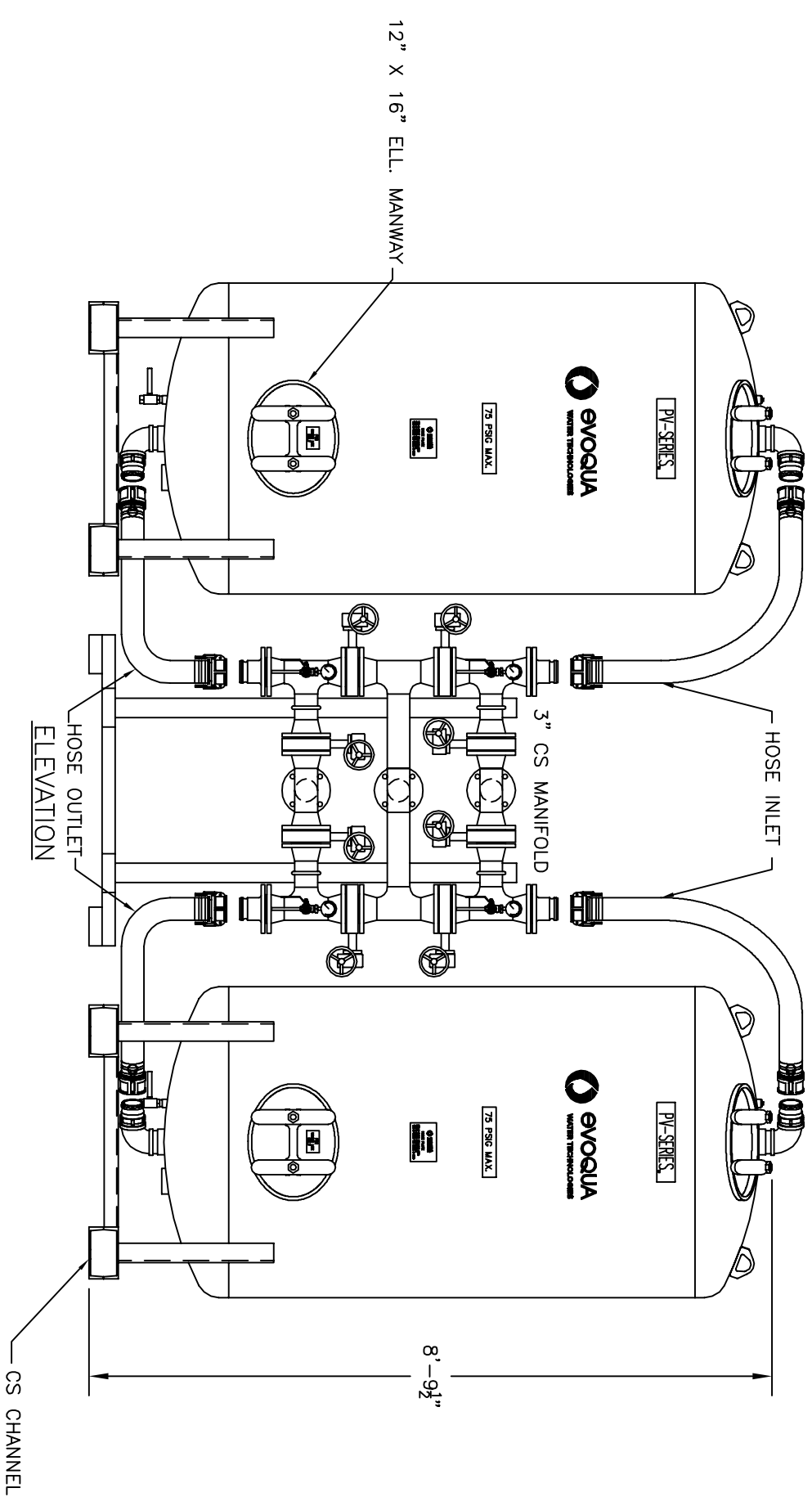
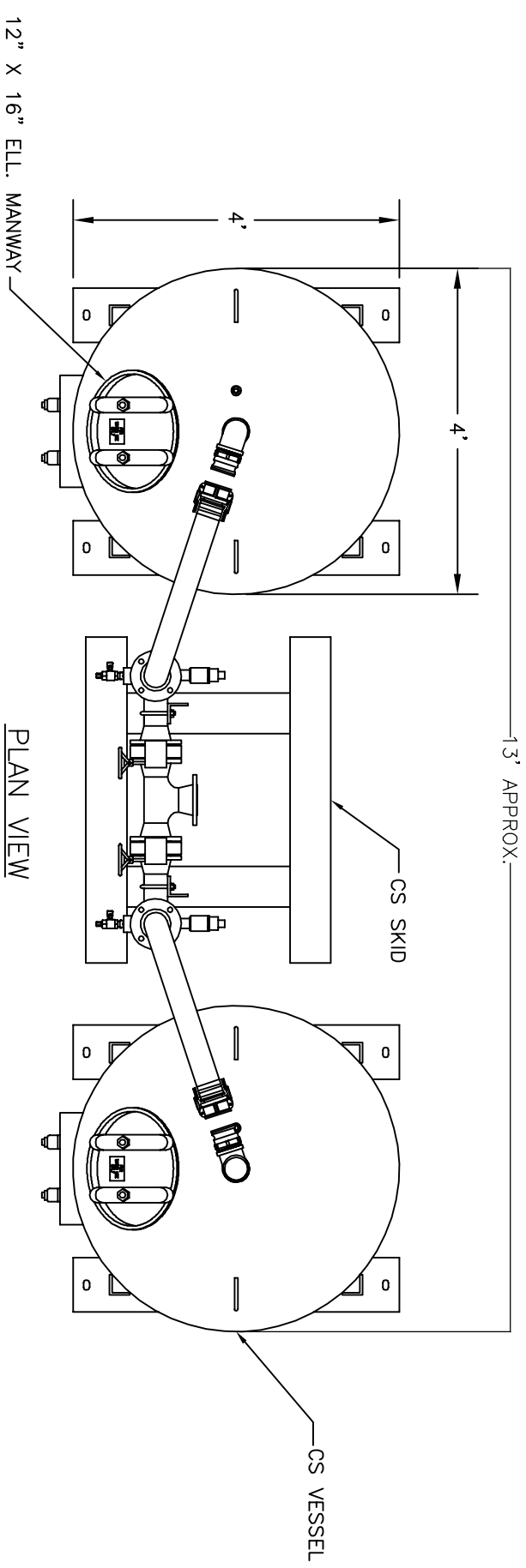

STD: 0302-243301	INTL REF:	BAR = 1" AT PLOT SCALE	REV	DESCRIPTION	DATE	OWN	CHNG	APVD	ECN	<p><small>CONTRACTOR'S RESPONSIBILITY: THIS DOCUMENT AND ALL INFORMATION CONTAINED HEREIN IS THE PROPERTY OF EVOSQUA WATER TECHNOLOGIES AND IS TO BE USED ONLY FOR THE PROJECT AND SITE SPECIFICALLY IDENTIFIED IN THE CONTRACT. NO PART OF THIS DOCUMENT IS TO BE REPRODUCED, COPIED, OR TRANSMITTED IN ANY FORM OR BY ANY MEANS, ELECTRONIC OR MECHANICAL, INCLUDING PHOTOCOPYING, RECORDING, OR BY ANY INFORMATION STORAGE AND RETRIEVAL SYSTEM, WITHOUT THE WRITTEN CONSENT OF EVOSQUA WATER TECHNOLOGIES. EVOSQUA WATER TECHNOLOGIES SHALL NOT BE LIABLE FOR ANY DAMAGES, INCLUDING CONSEQUENTIAL DAMAGES, ARISING FROM THE USE OF THIS DOCUMENT, EVEN IF ADVISED OF THE POSSIBILITY OF SUCH DAMAGES. THE USER OF THIS DOCUMENT AGREES TO HOLD EVOSQUA WATER TECHNOLOGIES HARMLESS FROM AND AGAINST ALL SUCH DAMAGES. THIS AGREEMENT SHALL BE A CONDITION OF THE DELIVERY OF THIS DOCUMENT AND CONSTITUTES ACCEPTANCE OF THE DOCUMENT BY THE USER.</small></p>	
DESIGNER	DATE	2-2-11	MANAGER	DATE	ENGINEER	DATE	FILE	SCALE	INS	<p>TITLE: PV2000SYS W/ 3IN CS MANIFOLD</p>	
PROJECT	CODE	PV2000SYS	DRAWING	CODE	PROJECT	CODE	PV2000SYS	SHEET	1	REV	0
		<p>EVOSQUA WATER TECHNOLOGIES</p> <p>850-527-2444</p>		<p>CLIENT</p>		<p>PROJECT</p>		<p>DRAWING</p>		<p>SHEET</p>	

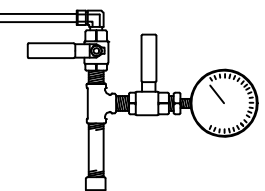
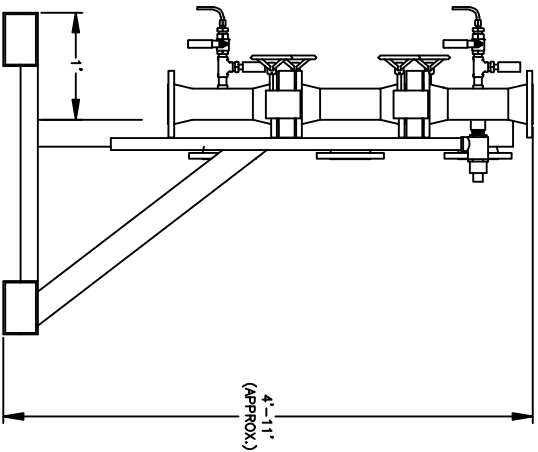
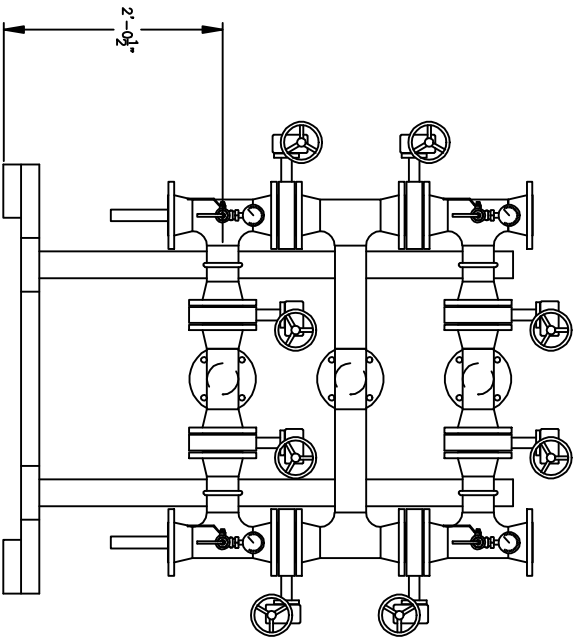
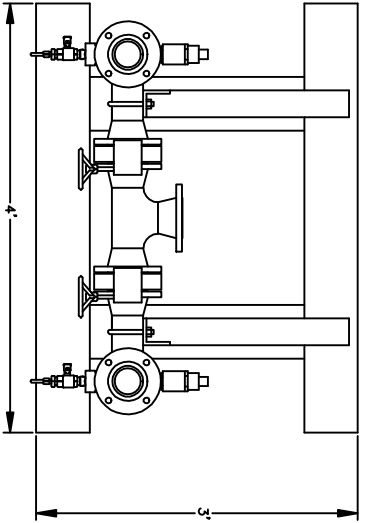

1/2" SAMPLE PORT
See Dwg. SP90ADAPT
(4 REQUIRED) NTS

* OPTIONAL BWO VALVE LOCATION

COMPANY CONFIDENTIAL
THIS DOCUMENT AND ALL INFORMATION CONTAINED HEREIN ARE THE PROPERTY OF SIEMENS AND ARE SUBMITTED IN CONFIDENCE. THEY ARE NOT TO BE DISCLOSED, REPRODUCED, COPIED, OR TRANSMITTED IN ANY MANNER WITHOUT THE EXPRESS WRITTEN CONSENT OF SIEMENS. IN NO EVENT SHALL THEY BE USED IN ANY MANNER THAT MIGHT BE DEEMED TO BE IN THE BEST INTERESTS OF SIEMENS. THIS DOCUMENT, ALONG WITH ALL COPIES AND EXTRACTS, AND ALL RELATED NOTES AND DRAWINGS, IS TO BE DESTROYED AND NOT REPRODUCED OR TRANSMITTED IN ANY MANNER WITHOUT THE EXPRESS WRITTEN CONSENT OF SIEMENS. ACCEPTANCE OF THE DELIVERY OF THIS DOCUMENT CONSTITUTES AGREEMENT TO THESE TERMS AND CONDITIONS.

DESIGNER	DATE
CAR	3/23/06
CHECKER	DATE
ENGINEER	DATE
MANAGER	DATE
FILE:	
SCALE:	NONE

TITLE	3 INCH CS MANIFOLD
CLIENT	WATER TECHNOLOGIES RED BLUFF, CA 530-527-2664
PROJECT	SIEMENS
CODE	MANT1003SHOP
DRAWING	1 OF 1
SHEET	1
REV	



CHARGE AIR 2000

*Universal Aircharging System
for Hydropneumatic Tanks*

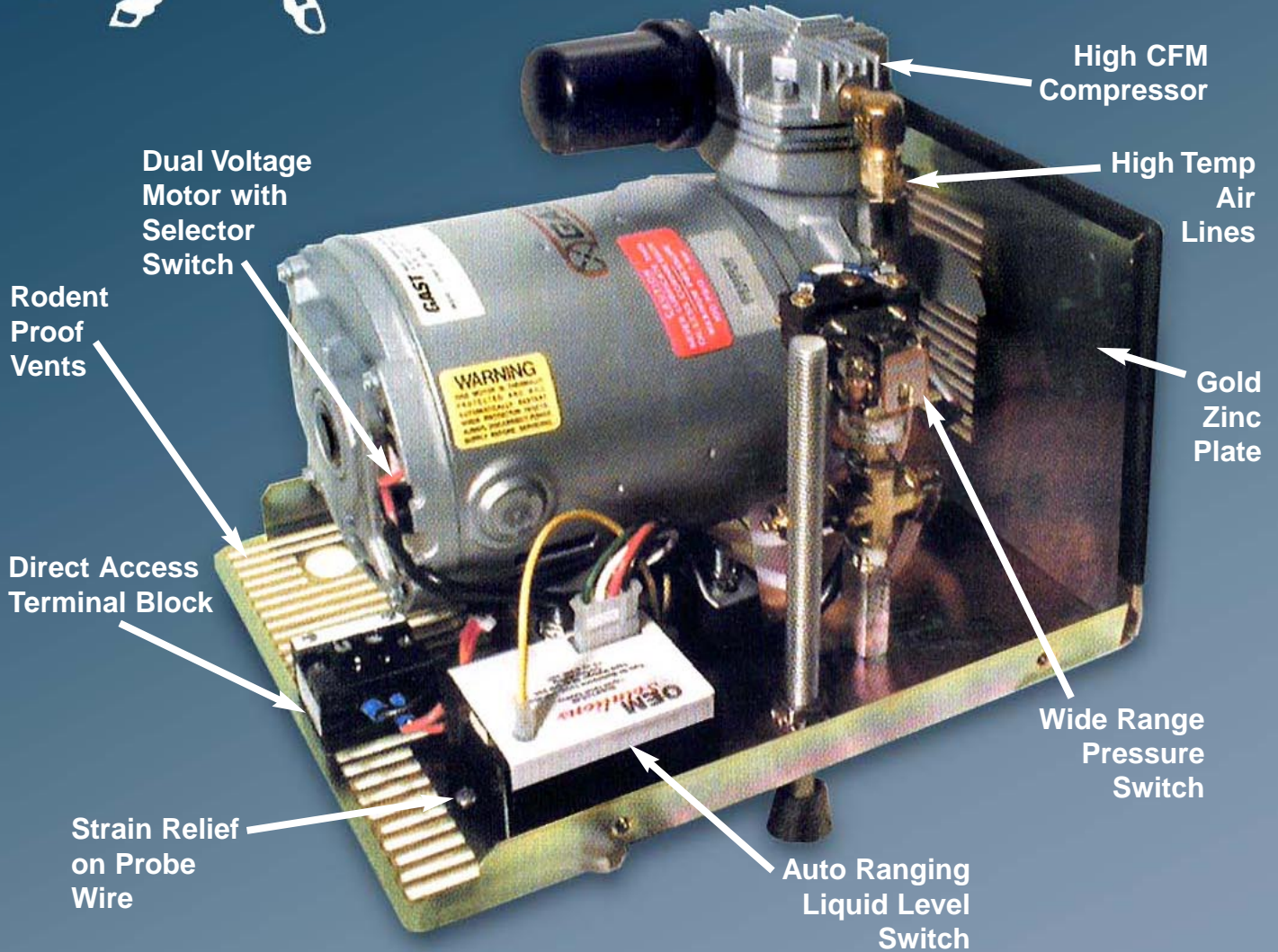

These innovative features and more, page 2.



MADE in the USA

MAASS
MIDWEST

MANUFACTURERS OF QUALITY WATER WELL ACCESSORIES

©2004, MAASS Midwest Manufacturing, Inc. All rights reserved.

ChargeAir 2000 *Universal Aircharging System for Hydropneumatic Tanks* *Manufactured by MAASS Midwest Mfg.*

11283 DUNDEE ROAD • HUNTLEY, IL 60142-0547

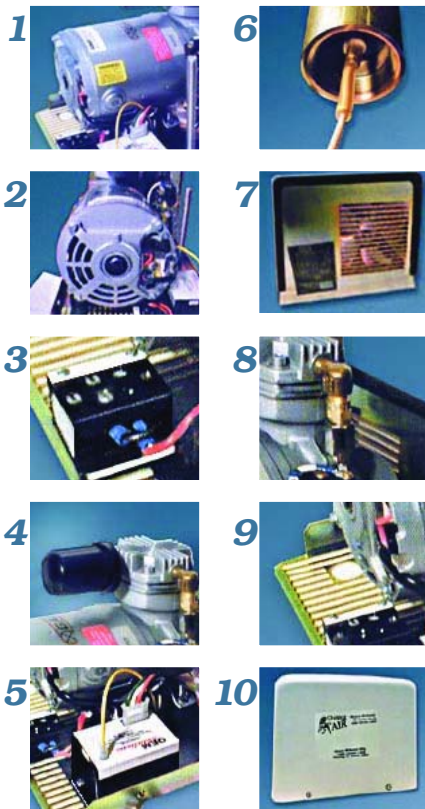

- 1** Dual voltage motor, auto ranging 115v/230v liquid level control, and wide pressure range which means one unit does it all, reducing inventory requirements.
- 2** **NEW** Dual voltage selector switch allows for easy voltage selection 115v/230v.
- 3** Direct access terminal block means faster installation.
- 4** High capacity compressor means faster tank charging and larger tank capacity.
- 5** **NEW** More durable liquid level switch increasing switch life.
- 6** Strain relief on probe connection means no call backs from cables broken by waves into the tank.
- 7** Stainless steel fasteners and gold zinc plating means longer life in harsh environmental conditions.
- 8** **NEW** Improved air lines to handle higher temperatures and pressures.
- 9** Rodent proof air vents means no down time from chewed wires or air hoses.
- 10** Heavy cover means your CA2000 will hold up better to sun exposure and harsh environments.

ChargeAir 2000

Model: CA 2000
Part Number: 992000
Description: 115/208/230 Volt, 50/60 Hz, single phase

SPECIFICATIONS

Maximum tank size20,000 Gallons
 Pressure range (adjustable)40 to 110 PSI
 Pressure Switch factory setting45 PSI cut-off
 Operating current at 115 volts.....6 amps
 Operating current at 208 volts3.5 amps
 Operating current at 230 volts.....3 amps
 Tank Connection2" FPT
 Size (LxWxH)14" x 10" x 17"
 Shipping weight37 lbs.

SPARE PARTS

DESCRIPTION	PART NUMBER
Compressor	000131
Cover	000133
Switch, liquid level - complete	000151

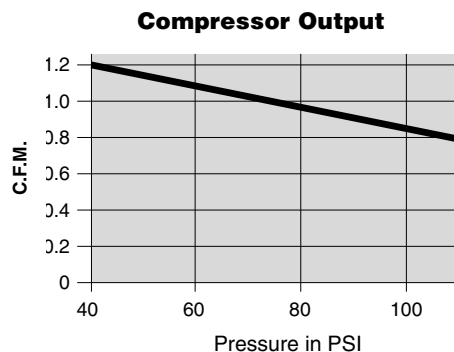
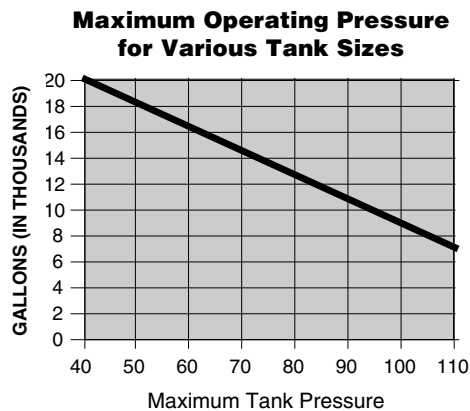

MANUFACTURERS OF QUALITY WATER WELL ACCESSORIES
 P. O. Box 547, 11283 Dundee Road, Huntley, IL 60142-0547
 (800) 323-6259 • IL AREA (847) 669-5135 • FAX (847) 669-3230
www.maassmidwest.com



Universal Aircharging System for Hydropneumatic Tanks

- ✓ *Dual Voltage System (115-240 VAC Single Phase)*
- ✓ *Auto Ranging Solid State Liquid Level Control*
- ✓ *Oil-less Long Life Compressor*
- ✓ *Adjustable Pressure Switch (40-110 PSI)*
- ✓ *One Year Warranty*

CHARGE AIR 2000 Standard Features....

Charge Air is an entirely self-contained dual voltage air charging system. All components are mounted on a corrosion resistant gold zinc plated base using stainless steel fasteners and enclosed within a heavy gauge high density polyethylene, weatherproof outer shell. The protected components include a long life oil-less compressor, auto ranging solid state liquid level control with isolated electrode circuit and time delay, and an adjustable 40 to 110 P.S.I. pressure switch.

CHARGE AIR 2000 Operation....

Charge Air utilizes three primary components: a liquid level switch, a pressure switch, and an air compressor. Through an electrode suspended into the tank from the Charge Air system, the liquid level control continuously monitors the water level of the tank. Simultaneously, the pressure switch monitors the air pressure in the tank. When the water level is above the electrode and the air pressure in the tank drops below its setting, the compressor will start and continue to run until the proper air pressure is reached or the water level drops below the electrode. This constant monitoring guarantees the optimum air charge is maintained.

MEMBER:



MANUFACTURERS OF QUALITY WATER WELL ACCESSORIES

P. O. Box 547, 11283 Dundee Road, Huntley, IL 60142-0547
(800) 323-6259 • IL AREA (847) 669-5135 • FAX (847) 669-3230

APPENDIX B
INSPECTION FORMS

SILVER CHOLLA MOBILE HOME PARK SUPPLY WELL OMM MONITORING CHECKLIST

DATE: _____ PRIOR INSPECTION DATE: _____

INSPECTOR: _____ LEAD TANK: _____ LAG TANK: _____

- _____ Yes; _____ No System operating/well pumping.
- _____ Yes; _____ No Connections are water tight (no leakage).
- _____ Yes; _____ No System sounds normal (no unusual noises).
- _____ Yes; _____ No Pressure meters working.
- _____ Yes; _____ No Opened W-1 sample port to verify flow.
- _____ Yes; _____ No Opened manifold sample ports to verify flow.
- _____ Yes; _____ No Open the valves on top of the vessel to check for and or release air.
- _____ Yes; _____ No Open and closed all valves to verify operation.
- _____ Yes; _____ No Record the totalizer reading and flow meter.
- _____ Yes; _____ No Food grade pipes are in fine condition.
- _____ Yes; _____ No Corrosion free.
- _____ Yes; _____ No Equipment firm (No loose equipment).
- _____ Yes; _____ No Rodent free.
- _____ Yes; _____ No Electrical Meter Reading _____.

- _____ Yes; _____ No Collected water samples.

SAMPLES

ID	TIME	BOTTLES	ANALYSIS	LOCATION/COMMENTS

DATE: _____

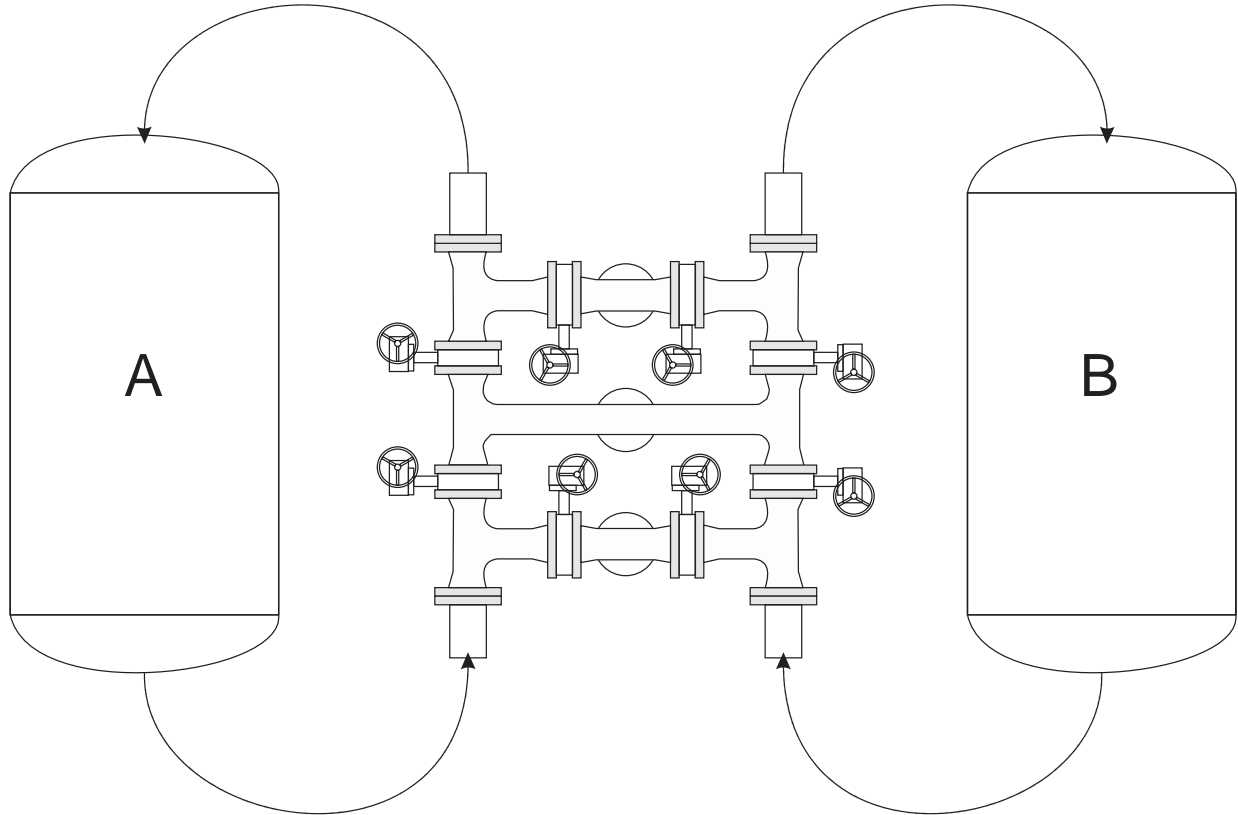
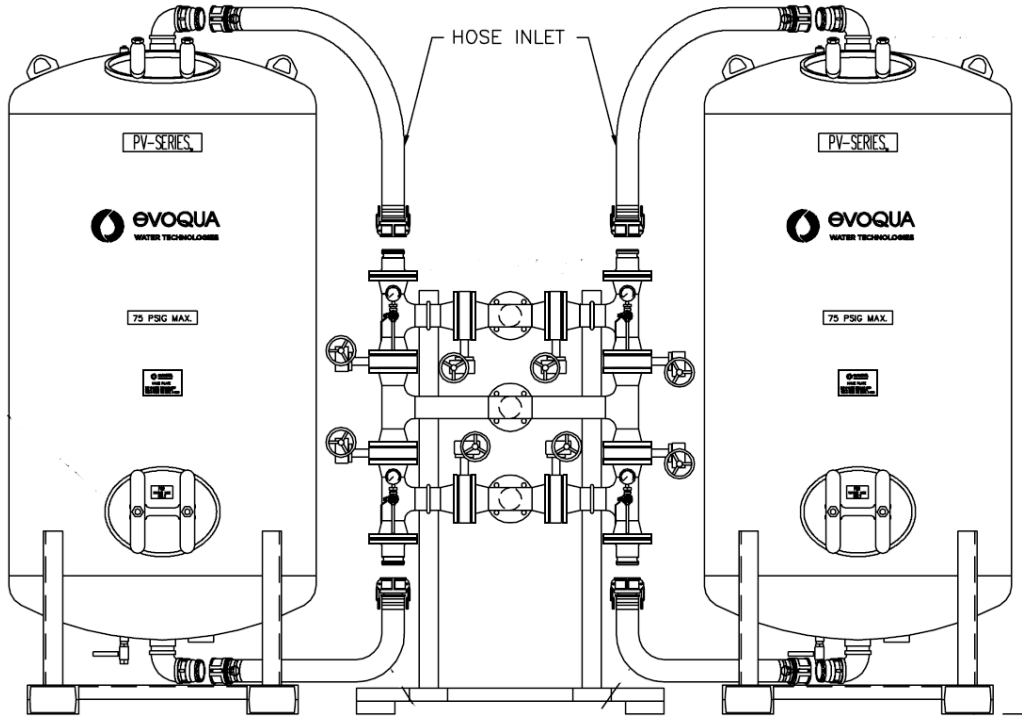

SILVER CHOLLA MHP TOTALIZER READINGS

DATE	TOTALIZER READING	CHANGE SINCE LAST READING	GALLONS (32.58x#)	DAYS SINCE LAST READING	USAGE GALLONS PER DAY	GPM	COMMENTS

TOTALIZER READING = ACRE FEET x 0.0001
1 Acre foot = 325851 gallons

32.5851 = Each # on Totalizer
1440 min/day

GROUNDWATER SAMPLE COLLECTION

SUMMARY OF METHOD

Water samples will be collected in accordance with laboratory requirements, environmental sampling standards and the requirements listed herein. Water samples will be collected at the various sample ports along the system by opening the valve(s) (while the pump is operating) and letting the water flow for 15 seconds or more to remove any stagnate water. Do not rinse or over fill containers with preservatives. Collect the samples by:

- filling clean laboratory provided bottle ware,
- labeling samples,
- store samples on ice,
- preparing chain-of-custody documentation and
- transporting to the laboratory.

HEALTH AND SAFETY WARNINGS

When working on-site, comply with all applicable OSHA requirements and the site's health/safety procedures. All proper personal protection clothing and equipment are to be worn.

PROCEDURE

PURGE: For each valve to be sampled, while the well pump is operating, field personnel will open the valve to be sampled allowing water to discharge for 15 seconds or longer, until stagnate water is discharged. At the discretion of the field personnel groundwater indicator parameter (e.g. temperature, pH, conductivity,...) may be collected. Documentation may be maintained in a detailed and well-organized format on the appropriate field data documentation forms.

SAMPLE: Collect water samples in appropriate sample containers from the valve discharge.

- Specific sample collection statements:
 - For VOC analysis by EPA Method 8260, collect headspace free water samples in pre-acidified 40 milliliter (ml) glass sample vials preserved with hydrochloric acid. Do not rinse the glass vials with discharge water prior to sample collection. To avoid aeration, hold the glass vial at an angle so the stream of water flows down the side. To eliminate any air bubbles, fill the vial until it forms a meniscus and replace the Teflon lined cap. Turn the vial upside down and tap it to check for air bubbles. If there is any headspace in samples collected for VOC analyses, discard the original vial and use a new pre acidified vial. Repeat this procedure until a sample without headspace is obtained. Collect three 40 ml vials for each VOC analysis for each well sampled. Place samples in a resealable plastic bag and store on ice in an ice chest immediately after collection.
 - For VOC analysis by EPA Method 524.2, collect headspace free water samples in pre-acidified 40 milliliter (ml) glass sample vials preserved with hydrochloric acid. Do not rinse the glass vials with discharge water prior to sample collection. To avoid aeration, hold the glass vial at an angle so the stream of water flows down the side. Add the laboratory provide ascorbic acid. To eliminate any air bubbles, fill the vial until it forms a meniscus and replace the Teflon lined cap. Turn the vial upside down and tap it to check for air bubbles. If there is any headspace in samples collected for VOC analyses, discard the original vial and use a new pre acidified vial. Repeat this procedure until a sample without headspace is obtained. Collect three 40 ml vials for each VOC analysis for each well sampled. Place samples in a re-sealable plastic bag and store on ice in an ice chest immediately after collection.
 - If coliform bacteria analysis is conducted, wear gloves when collecting samples. Do not rinse the bottles. The bottles are sterile, so care must be taken not to contaminate the bottle

or cap. Once the distribution line is flushed and the flow reduced, quickly open the bottle (but do not set the cap down), hold the cap by its outside edges only, and fill the sample bottle to just above the 100 ml line leaving 1 inch of headspace. Cap the bottle immediately and place it into a cooler with ice for delivery or overnight shipment to the laboratory.

- Attach labels to sample containers immediately after samples are collected.
- General sample collection statements:
 - If sample bottles for analytes contain preservatives or are sterile, do not rinse bottles; otherwise, triple-rinse unpreserved (not sterile) bottles prior to sample collection.
 - If samples are to be cooled, store on ice in ice chest immediately after collecting.
- Collect one field duplicate sample for every 10 samples collected during the sampling event. Analyze duplicate samples for the same compounds as original samples. Send duplicate samples along with the original samples to the primary laboratory.
- Include one trip blank sample containing reagent-free deionized water for VOC analysis to accompany each ice chest shipped each day for these analyses. The trip blanks will be prepared by the primary analytical laboratory, using reagent-free deionized water.
- Handle duplicate, trip blank, and field blank water samples in a manner identical to other water samples.
- Record all pertinent data concerning each sample on the groundwater sampling information field data form (Table SOP-I).
- Record all pertinent data concerning each duplicate, split, and blank sample.
- Complete chain of custody record.
- Package, store, and transport the samples to the laboratory at the conclusion of each sampling day. Samples will be delivered to the laboratories as quickly as possible, via laboratory courier, if available.

DATA AND RECORDS MANAGEMENT

FIELD ACTIVITY LOG: Field activities will be recorded on the appropriate field logs (attached tables) by the on-site field staff. All field data entries in the field notebook will be signed, dated, and kept as a permanent record. The field notebook will be the responsibility of the field team leader. Erroneous entries will be corrected by crossing a line through the error and entering the correct information. Corrections will be initialed by the person making the re-entry. Documented information may include:

- Project name and number;
- A description of field activities performed (e.g. procedures, field measurements, calibrations)
- Date and location of field activities
- Field Personnel
- Sub-contractors names and provided services
- Miscellaneous remarks and comments (e.g. weather conditions, significant events)

Completed field sheets and or scanned copies of completed field sheets will be maintained in the project file.

SAMPLE DOCUMENTATION: Sample identification documents will be prepared so that sample identification and chain of custody are maintained and sample disposition is controlled. The following sample identification documents are to be used:

- Sample identification label
- Chain of custody and analysis request forms

SAMPLE IDENTIFICATION LABEL: Preprinted adhesive sample labels will be secured to the sample containers by field personnel. Sample labels will be completed with waterproof ink. and contain the following information:

- Sample location/identifier
- Date and time sample was collected
- Analyses to be performed
- Preservation instructions
- Project number
- Sampler's initials
- Any other pertinent information
- Any special instructions to laboratory personnel

CHAIN-OF-CUSTODY: The chain of custody will be maintained and documented from the time of sample collection until the validation of analytical results. The chain of custody record is the document that records the transfer of sample custody and also serves to cross reference the sample identifier assigned by the QA Manager with the sample identifier assigned by the laboratory. The chain of custody record includes the following information:

- Sample location/identifier
- Project number
- Sampling date
- Sampling personnel
- Shipping method
- Sample description
- Sample volume
- Number of containers
- Sample destination
- Preservatives used
- Analyses to be performed
- Special handling and reporting procedures
- The identity of personnel relinquishing and accepting custody of the samples

The sampling personnel will be responsible for the samples and will sign the chain of custody record to document sample transferal or transport. Samples will be packaged in sealed containers for transport and dispatched to the appropriate laboratory for analysis with a separate chain of custody record accompanying each shipment. The method of transport, courier name(s), and other pertinent information will be entered on the chain of custody record. During transport, samples will be accompanied by the chain of custody record.

Once received at the laboratory, laboratory custody procedures apply. It is the laboratory's responsibility to acknowledge receipt of samples and verify that the containers have not been opened or damaged. It is also the laboratory's responsibility to maintain custody and sample tracking records throughout sample preparation and analysis.

QUALITY CONTROL AND QUALITY ASSURANCE

Quality Control and Quality assurance (QC/QA) during sampling will be accomplished by following this document. Laboratory QA procedures are specified in the laboratory's QA Manual. In addition, the Supervising Professional Geologist will review all documentation to ensure conformity with this document. In addition, the following field QC methods will be implemented during sample collection:

- Collect one field duplicate sample for every 10 samples collected during the sampling event. Send duplicate samples along with original samples to the primary laboratory. The purpose of the duplicate sample is to determine the precision of field sampling and laboratory analysis techniques. Field duplicate samples will be laboratory blind duplicates. A false well identifier will be assigned

for the sample identifier and recorded on the sample label and chain-of-custody record along with a false sample collection time. The actual sample location, sample time, and corresponding false sample identifier and sample time will be recorded.

- Include one trip blank sample containing reagent-free deionized water for VOC analyses to accompany each ice chest shipped each day for these analyses. The trip blanks will be prepared by the analytical laboratory using reagent-free deionized water. The purpose of the trip blank is to identify possible contamination associated with container preparation and sample transport.
- Identify duplicate samples in the same manner as all other samples.

CAUTIONS

The following cautions need to be considered when planning to collect groundwater samples if the below conditions occur:

- **DEGASSING:** If degassing is observed during sampling (e.g. bubbling) VOCs will be lost. Indicate on the COC that degassing was observed. When this happens, the groundwater data for VOCs will need to be qualified.
- **DEGASSING REACTION WITH PRESERVATIVE:** If a degassing reaction is observed when water contacts the preservative in a sample container (e.g. hydrochloric acid) dissolved gases and VOCs will be lost. When this happens, the groundwater data for dissolved gases and VOCs will need to be qualified. Additionally, a second sample may be collected into an unpreserved container and labeled accordingly.
- **AERATING:** When collecting the samples for VOCs analyses, avoid aerating the groundwater as it is purged. This can cause loss of the VOCs in the groundwater.
- **DIRECT SUNLIGHT/HOT CONDITIONS:** If possible avoid direct sun light and hot ambient air temperatures which may cause the groundwater to heat up. This may cause the groundwater to degas. When sampling under these conditions, the sampler will need to shade the equipment from the sunlight (e.g., umbrella, tent, etc.). If possible, sampling on hot days, or during the hottest time of the day, should be avoided.

PERSONNEL QUALIFICATIONS /RESPONSIBILITIES

All personnel collecting water samples should have the following minimum qualifications:

- First aid training;
- Medical clearance under the Hargis + Associates medical surveillance program; and
- Current respirator fit testing.

Project Name _____
 Project No./Task No. _____
 Project Manager _____
 QA Manager _____
 Phone No. _____
 Fax No. _____
 Sampler (SIGNATURE) _____

SAMPLE CONTAINERS			ANALYSIS REQUEST						ESTIMATED CONCENTRATION RANGE (ppb) FOR VOAs					SPECIAL HANDLING					

Sampler (PRINTED)

LAB ID	SAMPLE ID	SAMPLE COLLECTION		MATRIX			PRESERVATION					
		DATE	TIME	Soil	Ground water	Surface water	HCl	HNO3	NaOH	H2SO4	Ice	

Total number of Containers per analysis:	Total No. of Containers:
Remarks	

Relinquished by:	Date	Relinquished by:	Date
Company	Time	Company	Time
Relinquished by:	Date	Relinquished by:	Date
Company	Time	Company	Time

INSTRUCTIONS
 1. Fill out form completely and sign only after verified for completeness.
 2. Complete in ballpoint pen. Draw one line through error, initial, and date the correction.
 3. Indicate the number of sample containers in analytical request space, indicate choice with x.
 4. Note applicable preservatives, special instructions, and deviations from typical environmental samples.
 5. Consult project QA documents for specific instructions.

SAMPLE RECEIPT:

No. of containers correct
 custody seals secure
 received good condition/color
 conforms to COC documents
 Temp. on receipt C _____

Shipment Method: _____
 Send Results to: _____

9171 TOWNE CENTRE DRIVE, SUITE 375
 SAN DIEGO, CA 92122 (858)455-6500
 1640 SOUTH STAPLEY DRIVE, SUITE 209
 MESA, AZ 85204 (480) 345-0888
 7400 NORTH ORACLE ROAD, SUITE 202
 TUCSON, AZ 85718 (520) 881-7300
 Send invoice to San Diego, CA
 Attn: Accounts Payable

**FIGURE SOP-Q
SAMPLE IDENTIFICATION LABEL**

 HARGIS + ASSOCIATES, INC. Phone: 858.455.6500 9171 Towne Centre Drive, Suite 375, San Diego, CA 92122		
Client	H+A Project No.	Initials
Sample ID	Date / /	Time
Analyze for:		
Preservative/Special Instructions:		