



**TRANE®**

# Operation Maintenance Manual

---

## **Gear-Driven Centrifugal Water-Cooled Liquid Chillers with CH530 Controls**

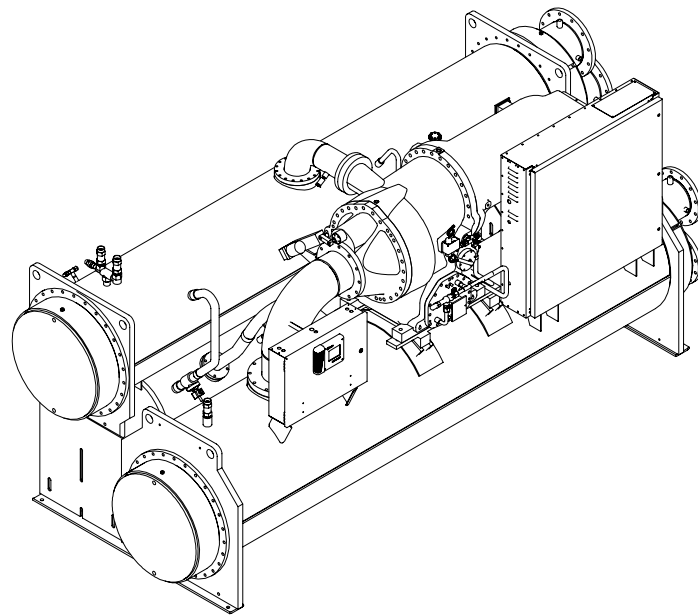

**Unit Model**  
**CVGF 400-1000 Ton Units**  
**(50 and 60 Hz)**

---

**X39640691020**

**CVGF-SVU02B-E4**

# Warnings and Cautions

---

## Warnings and Cautions

Notice that warnings and cautions appear at appropriate intervals throughout this manual. Warnings are provided to alert installing contractors to potential hazards that could result in personal injury or death, while cautions are

designed to alert personnel to conditions that could result in equipment damage.

Your personal safety and the proper operation of this machine depend upon the strict observance of these precautions.

**NOTICE:** Warnings and Cautions appear at appropriate sections throughout this manual. Read these carefully.

**⚠WARNING** – Indicates a potentially hazardous situation which, if not avoided, could result in death or serious injury.

**⚠CAUTION** – Indicates a potentially hazardous situation which, if not avoided, may result in minor or moderate injury. It may also be used to alert against unsafe practices.

**CAUTION** – Indicates a situation that may result in equipment or property-damage-only accidents.

# Contents

---

<b>Warnings and Cautions</b>	<b>2</b>
<b>General Information</b>	<b>4</b>
<b>Unit Control Panel (UCP)</b>	<b>22</b>
<b>Base Loading Control Algorithm</b>	<b>44</b>
<b>Control System Components</b>	<b>47</b>
<b>Machine Protection and Adaptive</b>	<b>62</b>
<b>Unit Startup</b>	<b>73</b>
<b>Unit Shutdown</b>	<b>76</b>
<b>Periodic Maintenance</b>	<b>77</b>



# General Information

---

## Literature History

**CVGF-SVU02A-E4  
(November 2002)**

This is a new manual.

## About this manual

Operation and maintenance information for models CVGF are covered in this manual. This includes both 50 and 60 Hz. CVGF centrifugal chillers equipped with the Tracer CH530 Chiller Controller system.

Carefully review this information and follow the instructions given to successfully operate and maintain a CVGF unit.

If mechanical problems do occur, contact a qualified service organization to ensure proper diagnosis and repair of the unit.

## Model Number

Refer to the Installation Manual.

## Product Description Block

A typical Product Description Block is shown in the Installation Manual.

## Unit Nameplate

The unit nameplate is located on the left side of the unit control panel.

**Note:** Trane starters are identified by a separate model number found on the starter.

# General Information

---

## Commonly Used Abbreviations

For convenience, a number of abbreviations are used throughout this manual. These are listed alphabetically below, along with a translation of each:

ASME = American Society of Mechanical Engineers

ASHRAE = American Society of Heating, Refrigerating and Air Conditioning Engineers

BAS = Building Automation System

CDBS = Condenser Bundle Size

CDSZ = Condenser Shell Size

CH530 = Tracer CH530 Controller.

CWR = Chilled Water Reset

CWR' = Chilled Water Reset Prime

DTFL = Design Delta-T at Full Load (for example, the difference between entering and leaving chilled water temperatures)

DV = DynaView™ Clear Language Display, also known as the Main Processor (MP)

ELWT = Evaporator Leaving Water Temperature

ENT = Entering Chilled Water Temperature

EXOP = Extended Operation

GBAS = Generic Building Automation Interface

GPM = Gallons-per-minute

HLUV = High Lift Unloading Valve.

Hp = Horsepower

HVAC = Heating, Ventilating, and Air Conditioning

IE = Internally-Enhanced Tubes

IPC = Interprocessor Communication

LCD = Liquid Crystal Display

LED = Light Emitting Diode

LLID = Low Level Intelligent Device (Sensor, Pressure Transducer, or Input/output UCP module)

MAR = Machine Shutdown Auto Restart (Non-Latching where chiller will restart when condition corrects itself.)

MMR = Machine Shutdown Manual Restart (Latching where chiller must be manually reset.)

MP = Main Processor

PFCC = Power Factor Correction Capacitor

PID = Proportional Integral Derivative

PSID = Pounds-per-Square-Inch (differential pressure)

PSIG = Pounds-per-Square-Inch (gauge pressure)

ODT = Outdoor Temperature

OPST = Operating Status Control

RLA = Rated Load Amps

RTD = Resistive Temperature Device Tracer CH530= Controls Platform used on this Chiller

TRMM = Tracer Communications

UCP = Unit Control Panel

# General Information

**Figure 1. General CVGF unit component**

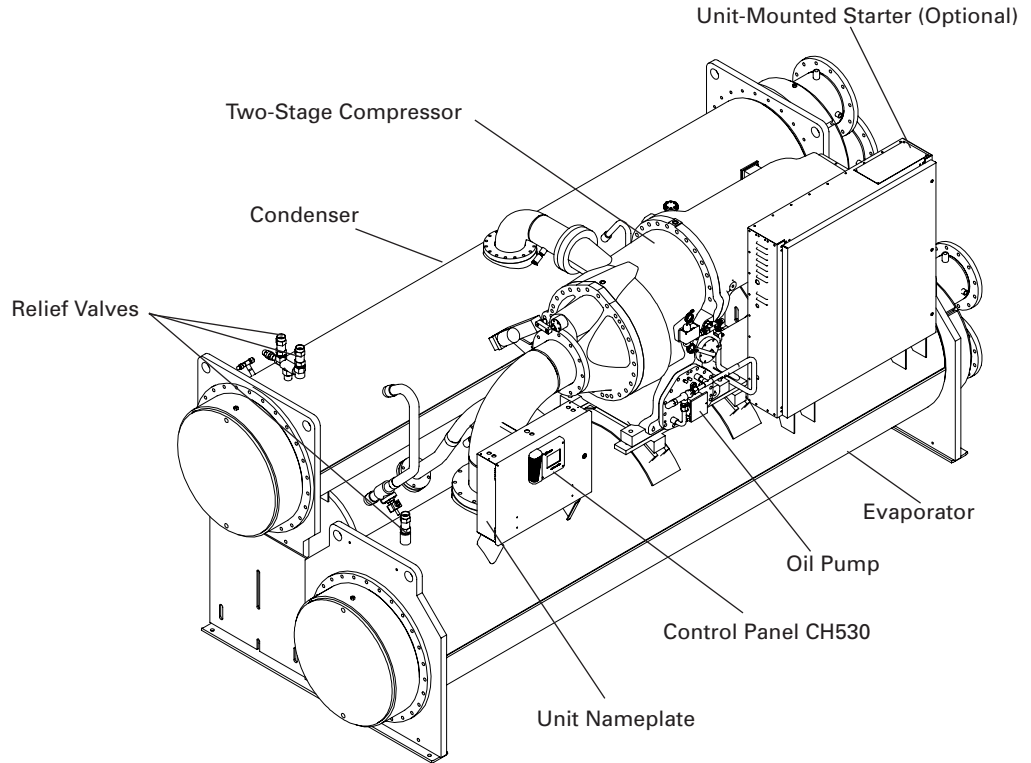

**Figure 2. Component location for typical CVGF unit (back view)**

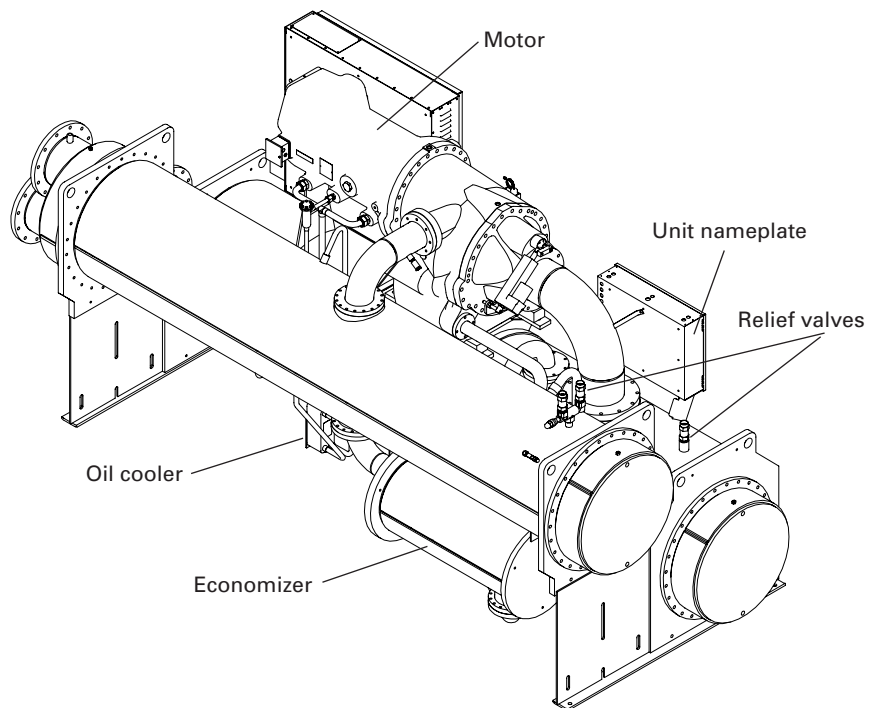

# General Information

## Cooling Cycle

The refrigeration cycle of the CVGF chiller can be described using the pressure-enthalpy diagram shown in Figure 3. Key state points are indicated and will be referred to in the following discussion. A schematic of the system showing refrigerant flow is given in Figure 4.

**Evaporator** - A liquid vapor refrigerant mixture enters the evaporator at state point 1. Liquid refrigerant is vaporized to state point 2 as it absorbs heat from the system cooling load. The vaporized refrigerant flows into the compressor first stage.

**Compressor first stage** - Refrigerant vapor is drawn from the evaporator into the first stage compressor. The first stage impeller accelerates the vapor increasing its temperature and pressure to state point 3.

Figure 3. P-H chart

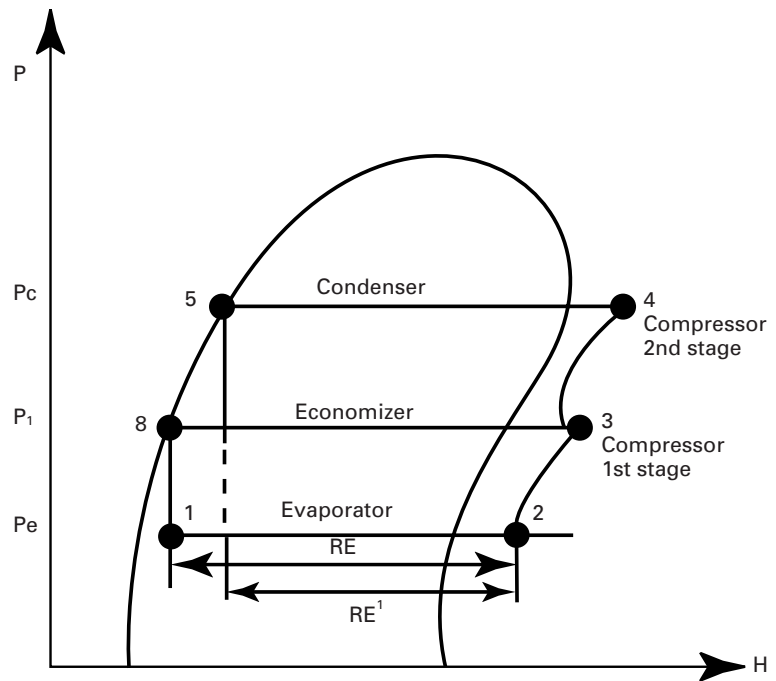

## General Information

---

### **Compressor second stage -**

Refrigerant vapor leaving the first stage compressor is mixed with cooler refrigerant vapor from the economizer. This mixing lowers the enthalpy of the vapor entering the second stage. The second stage impeller accelerates the vapor, further increasing its temperature and pressure to state point 4.

**Condenser** - Refrigerant vapor enters the condenser where the system cooling load and heat of compression are rejected to the condenser water circuit. This heat rejection cools and condenses the refrigerant vapor to a liquid at state point 5.

### **Economizer and refrigerant**

**orifice system** - Liquid refrigerant leaving the condenser at state point 5 flows through the first orifice and enters the economizer to flash a small amount of refrigerant at an intermediate pressure labeled P1. Flashing some liquid refrigerant cools the remaining liquid to state point 8.

Another benefit of flashing refrigerant is to increase the total evaporator Refrigeration Effect from RE' to RE. The economizer provides around 4 percent energy savings compared to chillers with no economizer.

To complete the operating cycle, liquid refrigerant leaving the economizer at state point 8 flows through a second orifice. Here refrigerant pressure and temperature are reduced to evaporator conditions at state point 1.

An innovative design feature of the CVGF chiller is maximizing the evaporator heat transfer performance while minimizing refrigerant charge requirements. This is accomplished by the Trane-patented falling film evaporator design. The amount of refrigerant charge required in CVGF is less than that in comparably sized chillers of flooded evaporator design.



# General Information

Figure 4. Refrigerant flow diagram

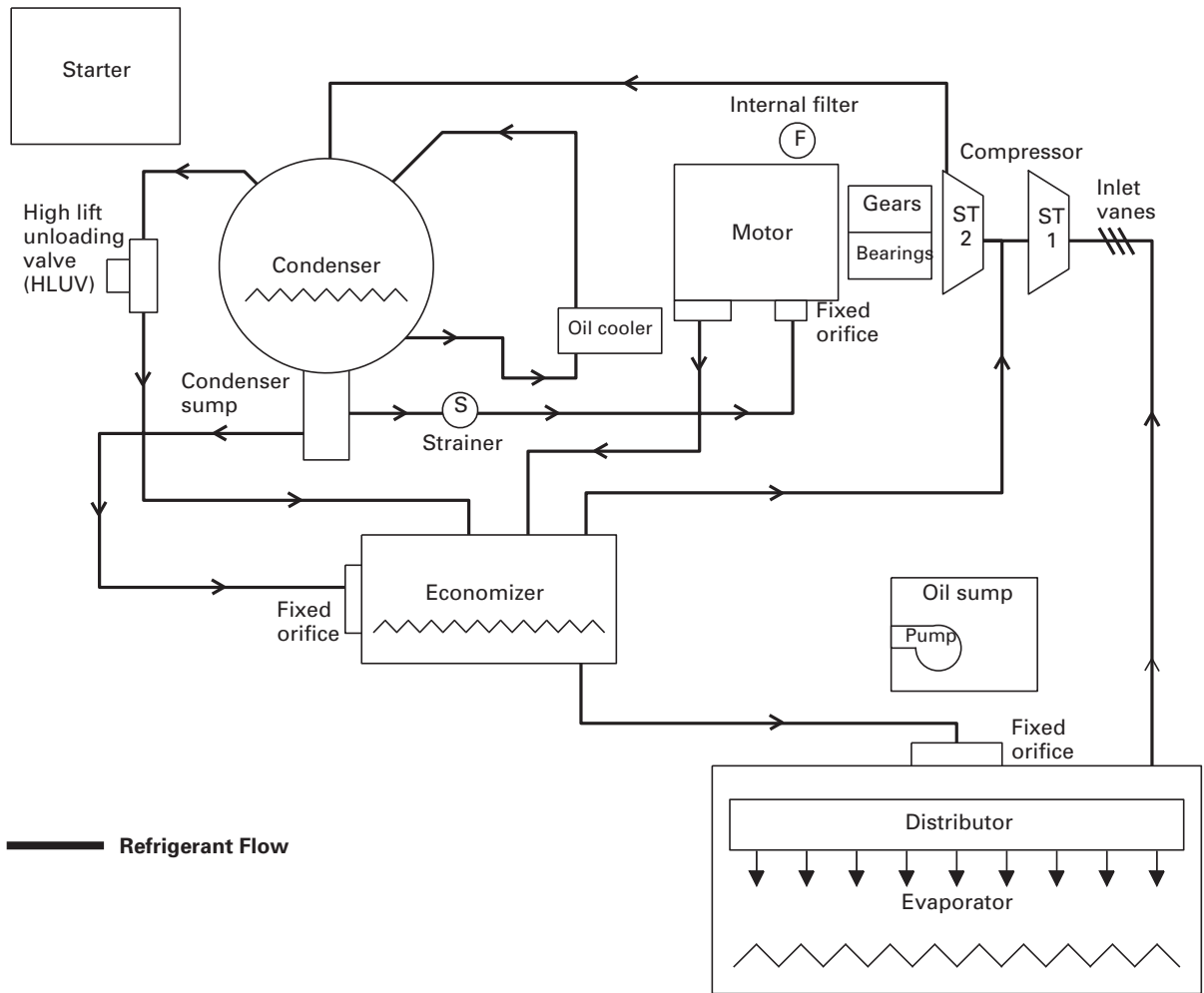

# General Information

---

## Compressor Description

The CVGF compressor consists of three distinct sections: the two-stage centrifugal compressor, the motor, and the gear box with integral oil sump. See Figure 5.

## Compressor

The centrifugal compressor is two-stage with high-strength aluminum alloy fully shrouded impellers. The impellers are tested at 25 percent over design operating speed. The rotating assembly is dynamically balanced for vibration of less than 5.1 mm/sec (0.2 ips peak velocities) at nominal operating speeds. The control system affords 20 to 100 percent capacity modulation by electrically actuated guide vanes upstream of each impeller.

# General Information

Figure 5. Compressor cross-section view

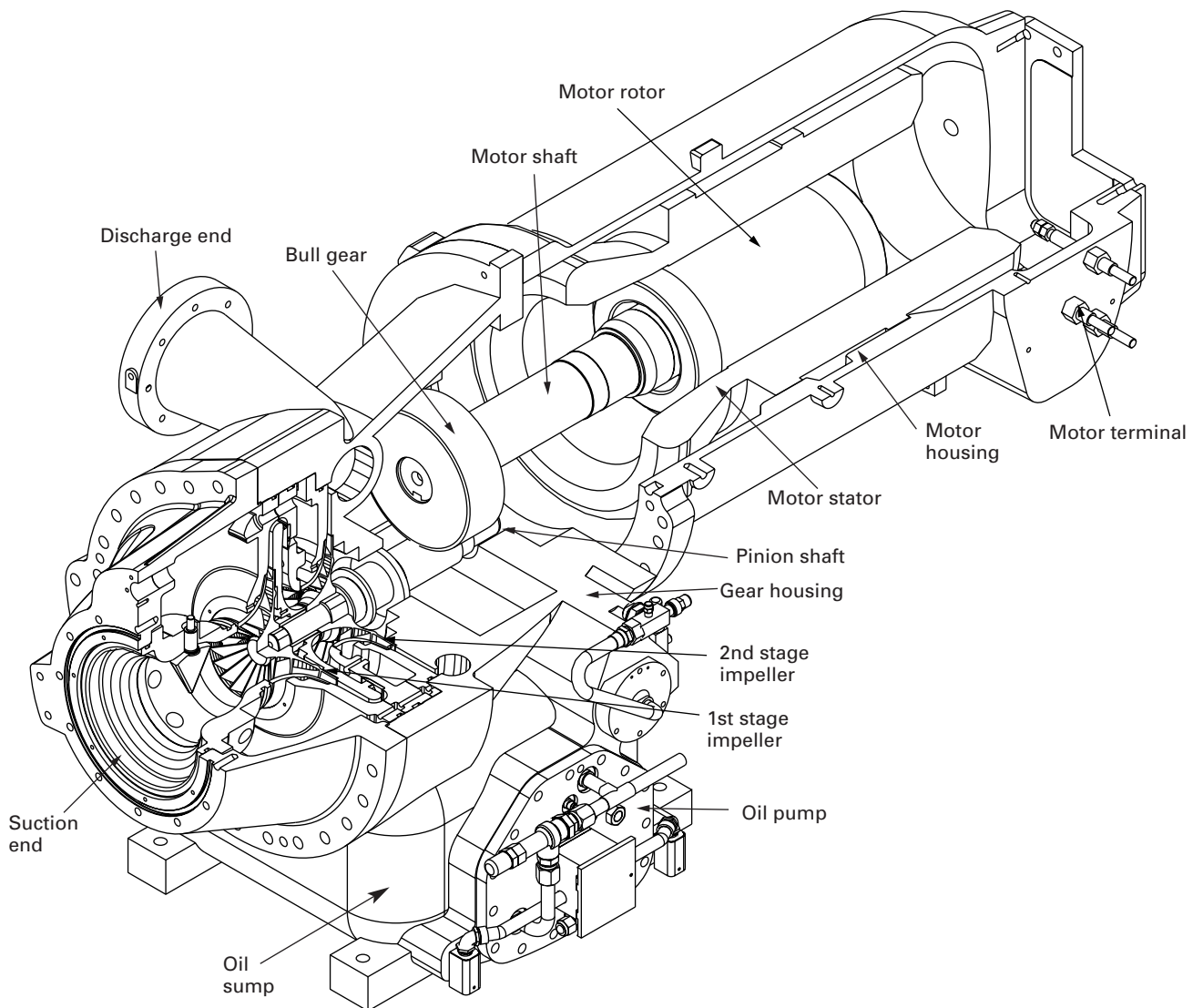

# General Information

---

## **Drive Train**

The drive train consists of helical bull and pinion gears. Gear tooth surfaces are case hardened and precision ground. The one-piece impeller shaft is supported by hydrodynamic thrust and radial bearings.

## **Motor**

The motor is a hermetic, liquid refrigerant cooled, two-pole, low-slip squirrel cage induction motor. A radial hydrodynamic bearing and duplex angular contact ball bearings support the rotor assembly. Winding-embedded sensors provide positive thermal protection.

## **Controls Overview**

### **Controls Operator Interface**

Information is tailored to operators, service technicians and owners. When operating a chiller, there is specific information you need on a day-to-day basis such as setpoints, limits, diagnostic information, and reports.

When servicing a chiller, you need different information and a lot more of it such as historic and active diagnostics, configuration settings, and customizable control algorithms, as well as operation settings.

By providing two different tools, one for daily operation and one for periodic service, appropriate information is readily accessible.

### **DynaView™ Human Interface**

For the operator, day-to-day operational information is presented at the panel. Up to seven lines of data (English or SI units) are simultaneously displayed on the touch-sensitive screen. Logically organized groups of information such as chiller modes of operation, active diagnostics, settings and reports put information conveniently at your fingertips. See Operator Interface Section for details.

### **TechView™ Chiller**

For the service technician or advanced operator all chiller status, machine configuration settings, customizable limits, and up to 60 active or historic diagnostics are displayed through the TechView™ interface. Using TechView™, a technician can interact with an individual device or a group of devices for advanced troubleshooting. LED lights and their respective TechView™ indicators visually confirm the viability of each device. Any PC that meets the system requirements may download the service interface software and Tracer CH530 updates. For more information on TechView™ visit your local Trane Service company, or The Trane Company's website at [www.trane.com](http://www.trane.com).

# General Information

Figure 6. CVGF sequence of operation overview

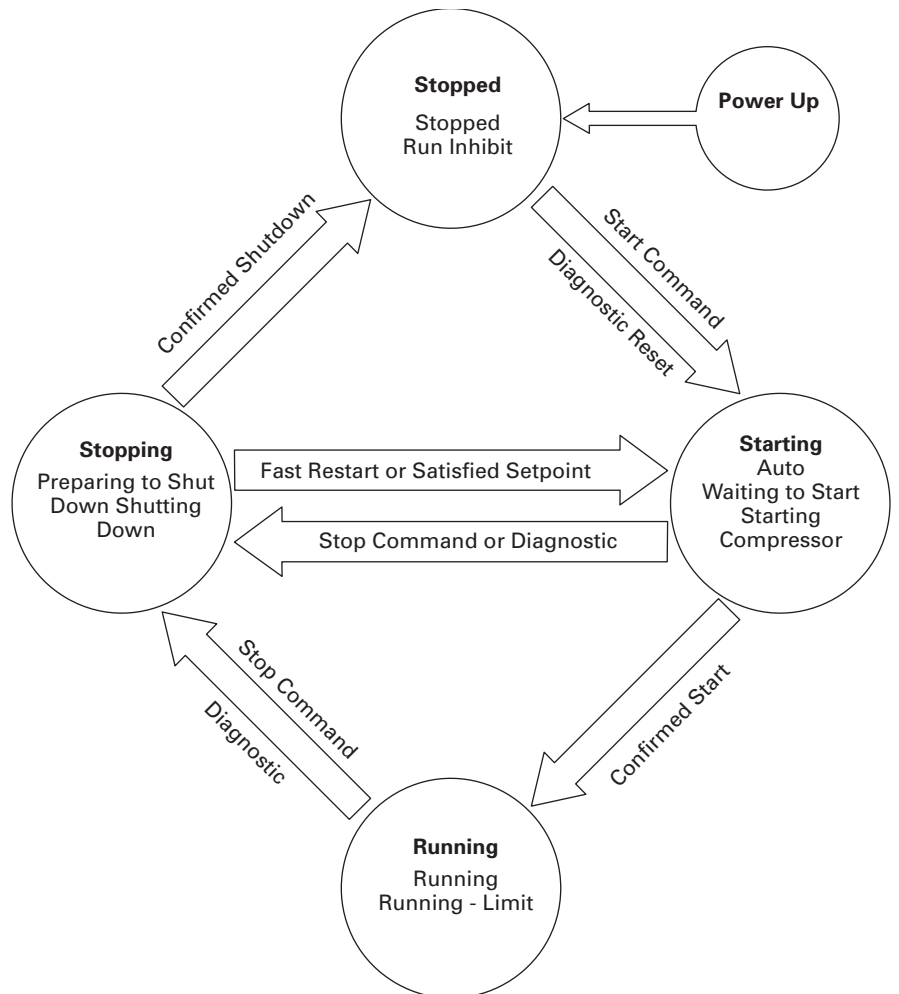

# General Information

**Figure 7. Sequence of operation: power up**

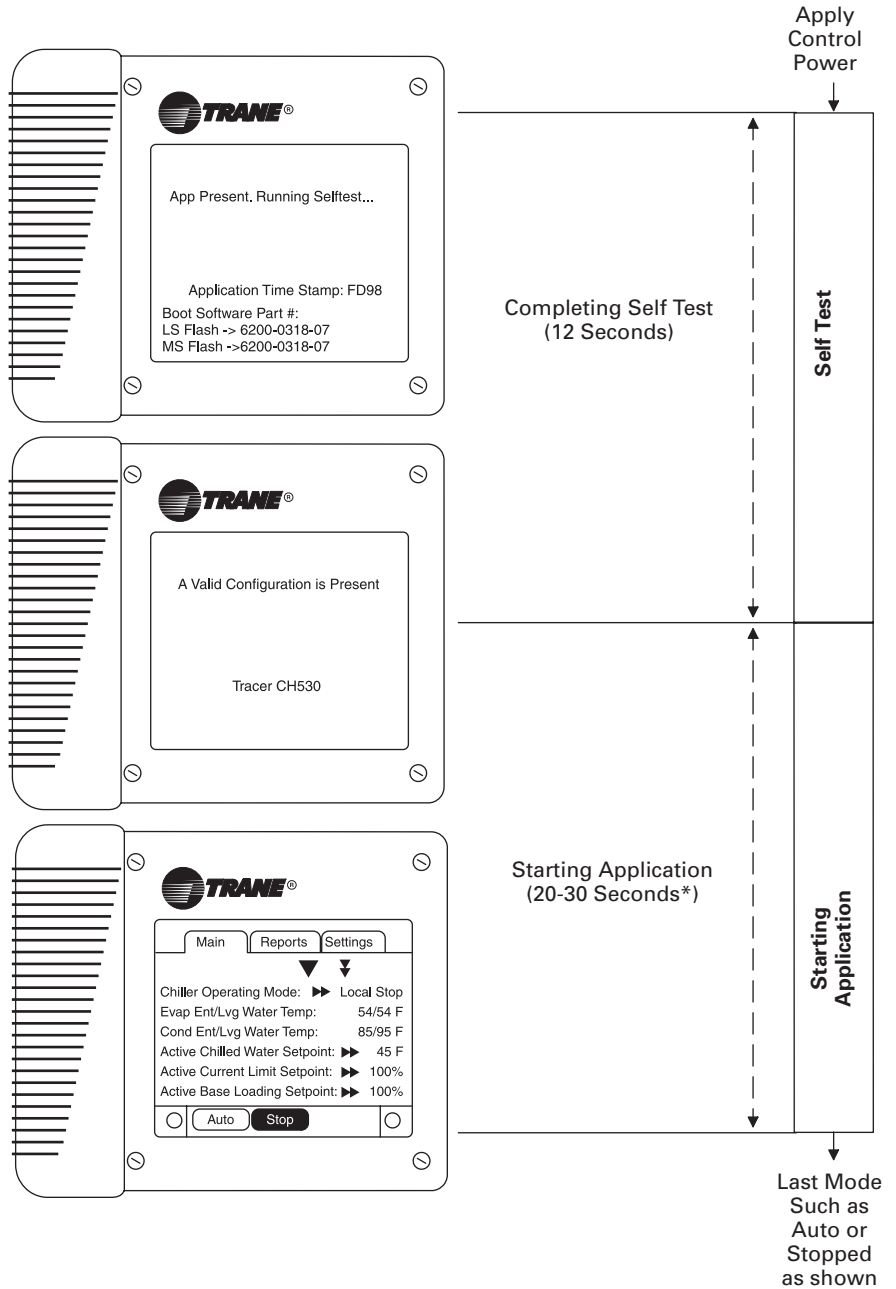

\*Note: The variation in DynaView Power Up time is dependent on the number of installed options.

# General Information

---

*Figure 8. Sequence of operation: running*

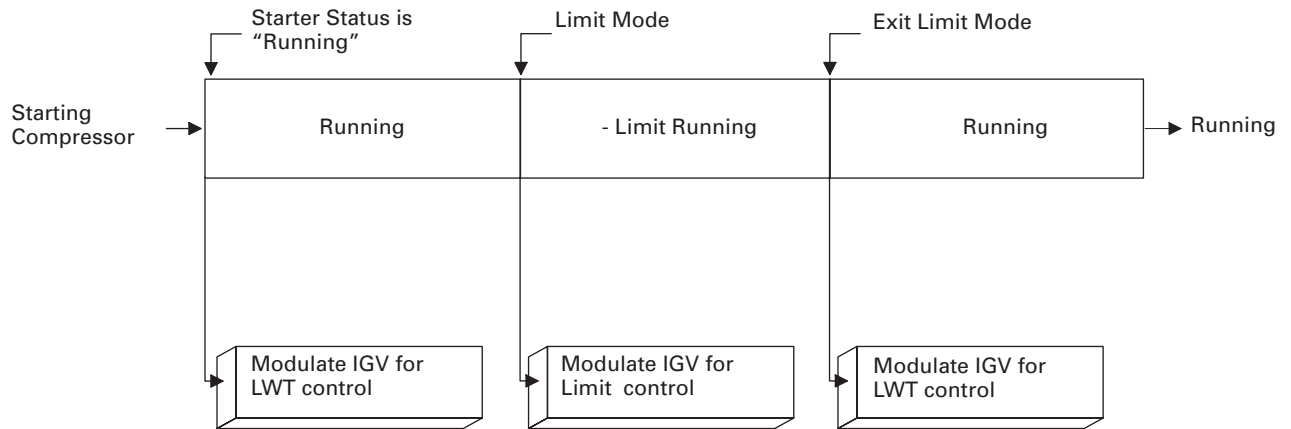

# General Information

**Figure 9. Immediate shutdown to stopped or run inhibit**

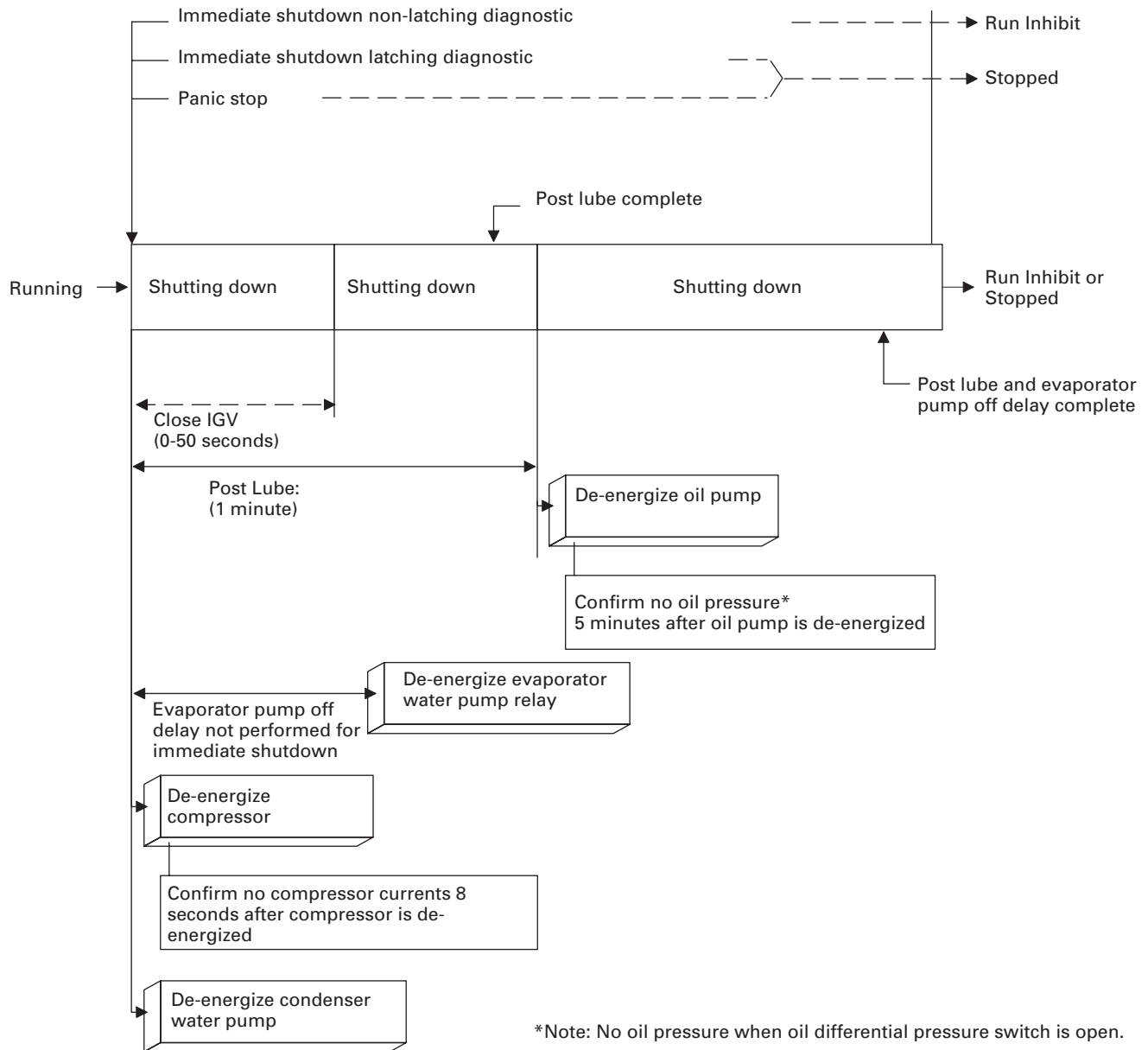



# General Information

Figure 10. CVFG sequence of operation: satisfaction setpoint

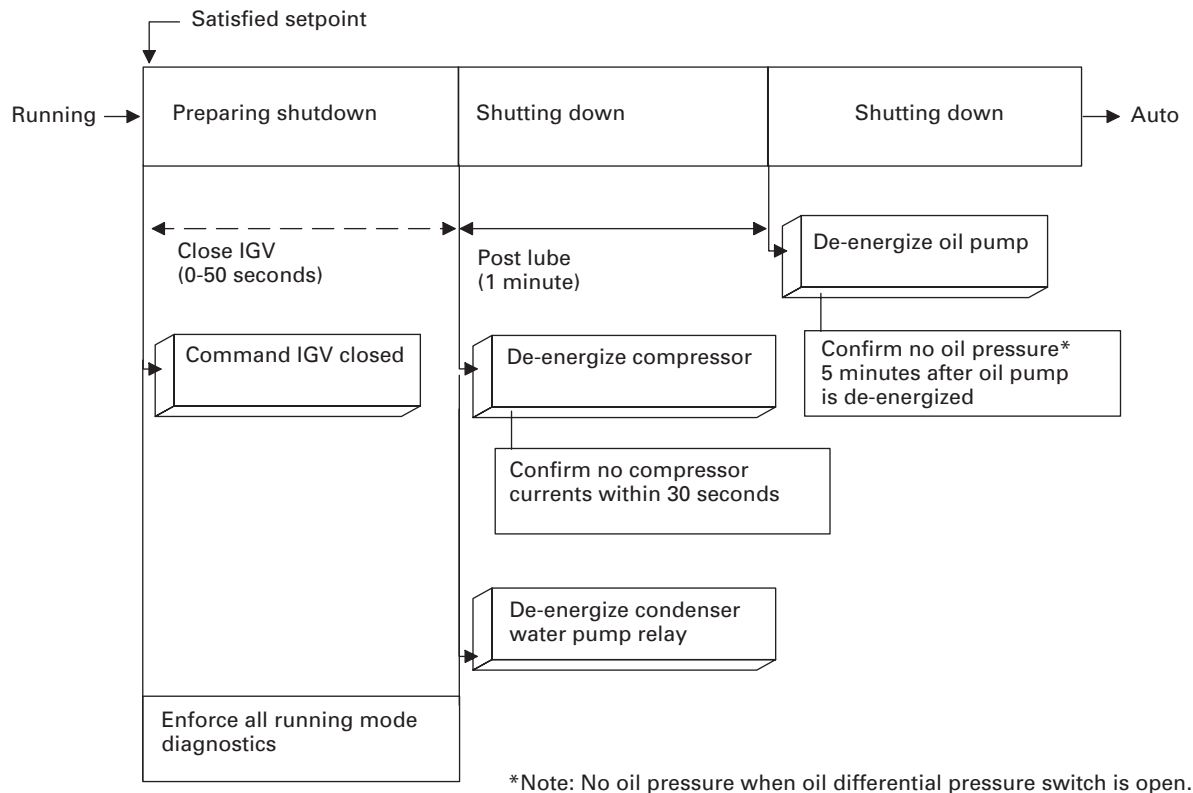

# General Information

---

## Oil Management

The primary purpose of Oil Management is to ensure appropriate and sufficient lubrication to the bearings during compressor operation and to minimize refrigerant dilution in the oil.

The Oil Management system performs safety checks and manages the operation of the Oil Pump and the Oil Heater. The sensor inputs used for these purposes are the Differential Oil Switch, and the Oil Temperature.

Two oil heater outputs exist, that should always operate simultaneously, for example, both on or both off.

**Note:** The Oil Pump and the Oil Heater are never energized at the same time.

Low Oil Temperature Start Inhibit Setpoint default is: 95° F.

When enhanced oil protection is enabled, the low oil temperature start inhibit is the saturated evaporator at 30°F (16.6°C) or 105°F (40.5°C), whichever is higher.

When enhanced oil temperature protection is enabled, the oil temperature setpoint is fixed at 136°F (57.8°C).

The oil temperature control setpoint range is settable from: 100 to 160°F (37.8 to 71.1°C)

## Essential Modes

The Oil-Management has the following modes:

### 1. Low Temperature Start Inhibit:

The oil temperature is at or below the low oil temperature start inhibit setpoint. The heater is energized to raise the oil temperature. See Low Temperature Start Inhibit section for information about Enhanced Oil Temp Protection.

This mode is indicated to the user.

2. Idle: The oil pump is off. The oil temperature is maintained by the heater, at the control-temperature setpoint +/- 2.5°F (1.4°C).

3. Pre-lube: The oil pump lubricates the bearing for 30 seconds before the compressor starts.

This mode is indicated to the user.

4. Running: The oil pump continues to lubricate the bearings when the compressor is running.

# General Information

---

5. Post-lube: The oil pump lubricates the bearings for 60 seconds after the compressor is stopped to ensure bearings remain lubricated as the compressor coasts to a stop.

If a start command is issued while in post-lube, a quick restart will be performed.

The post-lube mode is indicated to the user on DynaView™ and TechView™.

6. Manual: The oil pump can be commanded on and off in a manual mode.

## Oil Temperature Control

The oil heater is used to maintain the oil temperature within +/- 2.5°F (4.5°C) of the oil temperature control setpoint. The oil heater is commanded off when the oil pump is commanded on.

## Oil Differential Pressure Check

The Oil Differential Pressure Check validates the oil differential pressure before the oil pump is turned on. This check is necessary in case the differential pressure switch is not operational. Without this check, the differential oil pressure feedback is gone. This check is made after post-lube is complete to verify that the differential pressure has dropped to indicate no oil flow.

Here are the details:

- CH530 verifies that the pressure switch is reading no differential pressure with the oil pump off before proceeding with pre-lube.
- CH530 displays a mode Waiting for Low Oil Differential Press.
- The check is made if oil pump is off and before it is turned on.
- CH530 allows five minutes for the differential oil pressure switch to open.
- This check is performed on power up or reset also. If a MPL occurred or power up was within the post-lube time, oil pump is running so do not do the check.

# General Information

---

## Protective Diagnostics and their description

**Differential Oil Pressure Overdue** is a latching diagnostic that can come up while the unit is in pre-lube.

The differential pressure switch status is used instead of the Low Differential Oil Pressure Cutout setpoint.

**Low Differential Pressure Cutout** is a latching diagnostic that can come up while the unit is running. Oil pressure is indicative of oil flow and active oil pump operation. Significant fall in oil pressure is indicative of failure of the oil pump, oil leakage, or other blockage in the oil circuit.

Once oil flow has been established, if the differential pressure switch indicates there is not oil pressure for 2 seconds, this diagnostic will be issued.

**Unexpected Differential Oil Pressure** is a latching diagnostic that can come up while the unit is idle and is implemented to recognize and ensure that the pressure switch is operational and that it is open for a period of five minutes.

# General Information

Figure 11. Oil circuit diagram

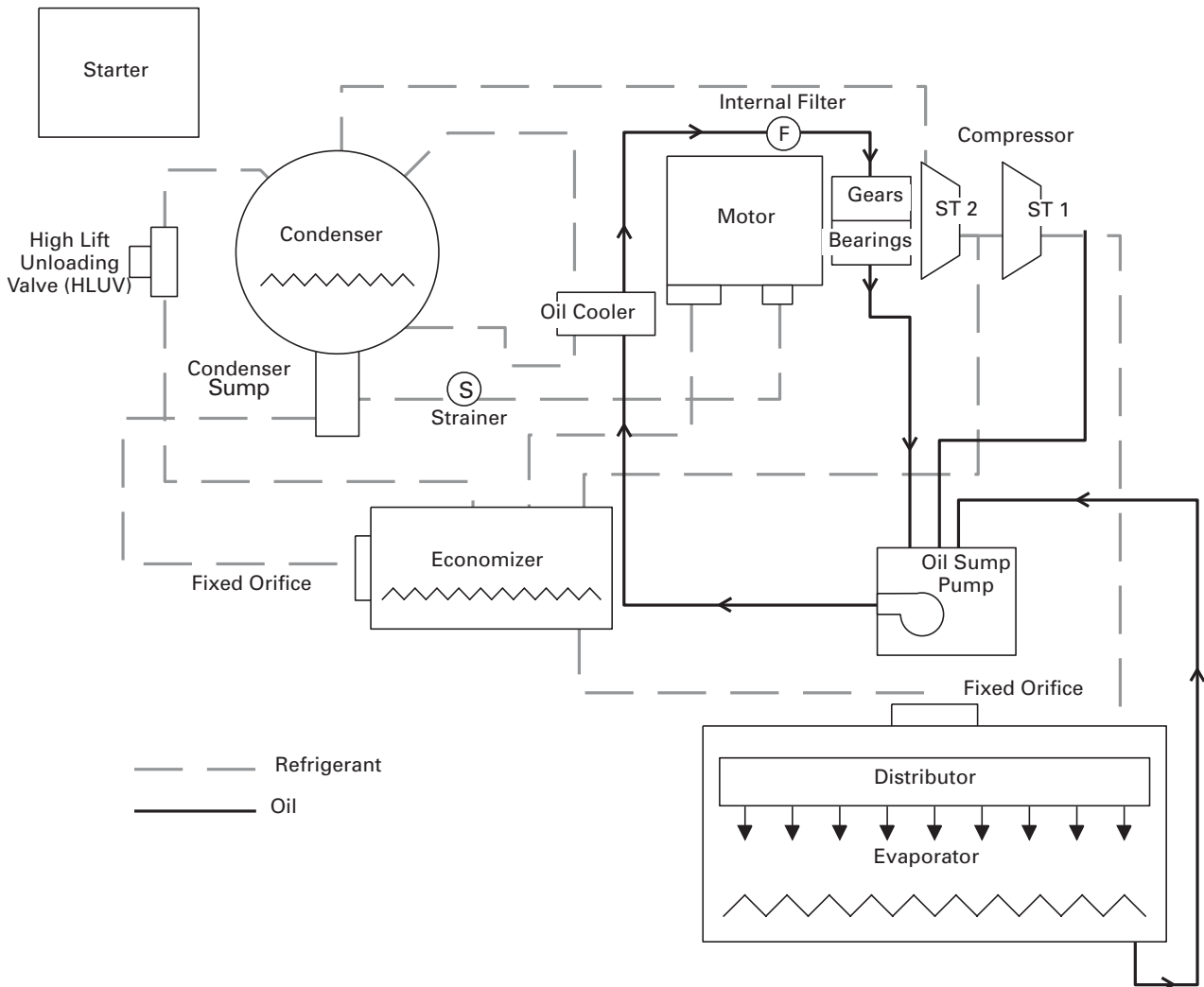

# Unit Control Panel (UCP)

## Control Panel Devices and Unit Mounted Devices

### Unit Control Panel (UCP)

Safety and operating controls are housed in the unit control panel, and the starter panel. The UCP's operator interface and main processor is called the DynaView™ and is located on the UCP door. (See Operators interface section for detailed information)

The UCP houses several other controls modules called panel mounted LLID (Low Level Intelligent Device), power supply, terminal block, fuse, circuit breakers, and transformer. The IPC (Interprocessor communication) bus allows the communications between LLID's

and the main processor. Unit mounted devices are called frame mounted LLID's and can be temperature sensors or pressure transducers. These and other functional switches provide analog and binary inputs to the control system.

**Figure 12. Control panel**

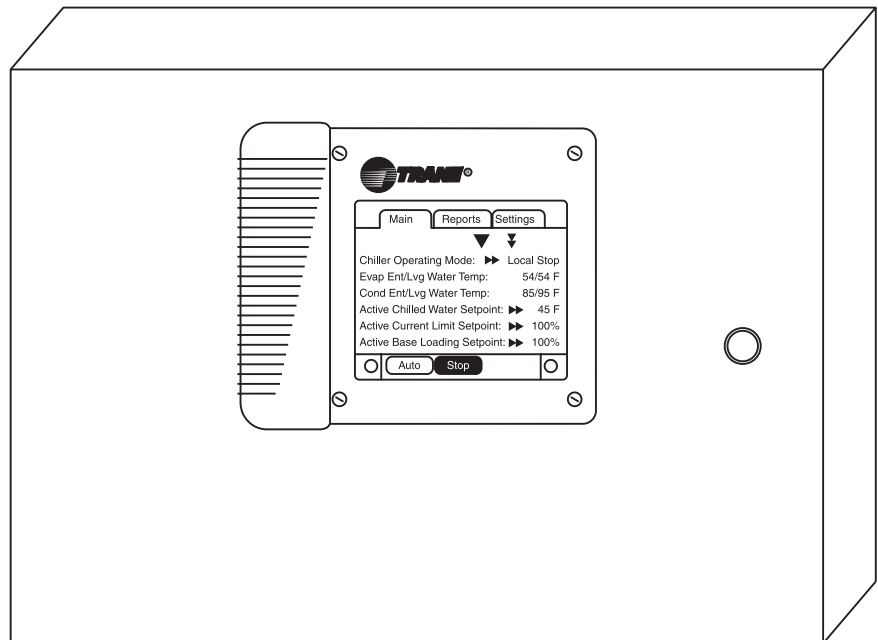

## Unit Control Panel (UCP)

---

### Tracer CH530 Chiller Controller

Tracer CH530's Main Processor, DynaView™, is fast and keeps the chiller online whenever possible. Smart sensors collect three rounds of data per second, 55 times the data collection speed of its predecessor. Each device (a sensor) has its own microprocessor that simultaneously converts and accurately calibrates its own readings from analog to digital.

Because all devices are communicating digitally with the DynaView™, there is no need for the main processor to convert each analog signal one at a time. This distributed logic allows the main processor to focus on responding to changing conditions in the load, the machine, its ancillary equipment, or its power supply. Tracer CH530 constantly receives information about key data parameters, temperatures and currents. Every five seconds a multiple objective algorithm compares each parameter to its programmed limit. The chiller's Adaptive Control™ capabilities maintain overall system performance by keeping its peak efficiency.

Whenever the controller senses a situation that might trigger a protective shutdown, it focuses on bringing the critical parameter back into control. When the parameter is no longer critical, the controller switches its objective back to controlling the chilled water temperature, or to another more critical parameter should it exist.

### Variable water flow through the evaporator

Chilled water systems that vary water flow through chiller evaporators have caught the attention of engineers, contractors, building owners, and operators. Varying the water flow reduces the energy consumed by pumps, while requiring no extra energy for the chiller. This strategy can be a significant source of energy savings, depending on the application. With its faster and more intelligent response to changing conditions, Tracer CH530 reliably accommodates variable evaporator water flow and its effect on the chilled water temperature. These improvements keep chilled water flowing at a temperature closer to its setpoint.

## Unit Control Panel (UCP)

---

The DynaView™ (DV) Operator Interface contains the Main Processor (MP) which communicates commands to other modules, collecting data, status and diagnostic information from the other modules over the IPC (Inter Processor Communications) link. The Main Processor software controls water flows by starting pumps and sensing flow inputs, establishes a need to heat or cool, performs pre-lube, performs post-lube, starts the compressor, performs water temperature control, establishes limits, and pre-positions the inlet guide-vanes.

The MP contains non-volatile memory both checking for valid set points and retaining them on any power loss. System data from modules (LLID) can be viewed at the DynaView™ operator interface. Such as evaporator and condenser water temperatures, outdoor air temperature, evaporator and condenser water pump control, status and alarm relays, external auto-stop, emergency stop, and evaporator and condenser water flow switches.

**DynaView™ presents three menu tabs across the top which are labeled "MAIN, REPORTS, and SETTINGS".**

The **Main screen** provides an overall high level chiller status so the operator can quickly understand the mode of operation of the chiller.

The Chiller Operating Mode will present a top level indication of the chiller mode (Auto, Running, Inhibit, Run Inhibit, and so forth) The "additional info" icon will present a subscreen that lists in further detail the subsystem modes.

*Figure 13. DynaView™ main processor*





# Unit Control Panel (UCP)

---

Main screen content can be viewed by selecting the up or down arrow icons. The Main screen is the default screen. After an idle time of 30 minutes.

DynaView™ (DV) is the **operator interface** of the Tracer CH530 control system utilized on the CTV machines. The DynaView™ enclosure is 9.75" (24.8 cm) wide, 8" (20.3 cm) high and 1.6" (4.1 cm) deep. The DynaView™ display is approximately 4" (10.2 cm) wide by 3" (7.6) high. Features of the display include a touch screen and long life LED backlight. This device is capable of operating in 0 - 95 percent relative humidity (non-condensing). The enclosure includes a weather tight connection means for the RS232 TechView™ connection.

**Touch screen key functions** are determined completely in the software and change depending upon the subject matter currently being displayed. The user operates the touch sensitive buttons by touching the button of choice. The selected button is darkened to indicate it is the selected choice. The advantage of touch sensitive buttons is that the full range of possible choices as well as the current choice is always in view.

Up or down **arrow buttons** are used to allow a continuously variable setpoint, such as leaving water setpoint. The value changes by touching the up or down arrows.

**Action buttons** are buttons that appear temporarily and provide the operator with a choice such as **Enter** or **Cancel**. The operator indicates his choice by touching the button of choice. The system then takes the appropriate action and the button typically disappears.

DynaView™ consists of various screens, each meant to serve a unique purpose of the machine being served. **Tabs** are shown row across the top of the display. The user selects a screen of information by touching the appropriate tab. The folder that is selected will be brought to the front so it's contents are visible

## Unit Control Panel (UCP)

---

The main body of the screen is used for description text, data, setpoints, or keys (touch sensitive areas) The **double up arrows** cause a page by page scroll either up or down. The **single arrow** causes a line by line scroll to occur. At the end of the screen, the appropriate scroll buttons will disappear.

The bottom of the screen is the persistent area. It is present in all screens and performs the following functions. The **left circular area** is used to reduce the contrast and viewing angle of the display. The **right circular area** is used to increase the contrast and viewing angle of the display. The contrast control will be limited to avoid complete "light" or complete "dark", which would potentially confuse an unfamiliar user to thinking the display was malfunctioning.

**Persistent keys**, horizontal at the bottom of the display, are those keys that must be available for operation regardless of the screen currently being displayed. These keys are critical for machine operation. The **Auto and Stop** keys will be presented as radio buttons within the persistent key display area. The selected key will be dark. The chiller will stop when the **Stop** key is touched, entering the stop sequence. Pressing the "Immediate Stop" button will cause the chiller to stop right away.

The AUTO and STOP, take precedence over the ENTER and CANCEL keys. (While a setting is being changed, AUTO and STOP keys are recognized even if ENTER or CANCEL has not been pressed. Selecting the Auto key will enable the chiller for active cooling.

## Unit Control Panel (UCP)

The **machine-operating mode** indicates the operational status of the chiller. A subscreen with additional mode summary information will be provided. When the user scrolls down the screen the Machine Operation Mode will remain stationary

On DynaView™, the user will be presented with a single line of text that represents the 'top-level' operating state of the machine. These top-level modes are shown in the Table 1. Additional information (if it exists) regarding the machine operating state will be available to the user by selecting the "additional information" button (double right arrow) next to the top-level operating mode. These sub-level modes are shown Table 1.

The TOP LEVEL MODE is the text seen on the single top level chiller system operating mode line. The SUB LEVEL MODE is the text seen on the operating mode sub-menu. The operating mode sub-menu may have up to six (6) lines of text displayed.

The BAS CODE is the code that will be sent via COMM4/5 to the Tracer Summit system as the chiller system mode. Note that each top level mode may contain multiple sub level modes. In general, the BAS CODE will reflect the top level mode and not the sub level mode.

**Figure 14.**



# Unit Control Panel (UCP)

**Table 1. A general description of the top level modes is show in the following table.**

Top Level Mode	Description
Stopped	Unit inhibited from running and will require user action to go to Auto.
Run Inhibit	Unit inhibited from running by Tracer, External BAS, or an Auto Reset diagnostic.
Auto	Unit determining if there is a need to run.
Waiting To Start	Unit waiting for tasks required prior to compressor start to be completed.
Starting Compressor	Unit is starting compressor.
Running	Compressor is running with no limits in effect.
Running – Limit	Compressor is running with limit in effect.
Preparing To Shutdown	Unit is closing inlet guide vanes prior to compressor shutdown.
Shutting Down	Compressor has been stopped and unit is performing shutdown tasks.

**Figure 15.**



# Unit Control Panel (UCP)

Top Level Mode	Sub Level Mode	Reference BAS Code
SYSTEM RESET	Boot & Application software part number, self-test, and configuration validity screens will be present.	NA
Stopped	Local Stop	00
Stopped	Panic Stop	00
Stopped	Diagnostic Shutdown – Manual Reset	00
Run Inhibit	Tracer Inhibit	100
Run Inhibit	External Source Inhibit	100
Run Inhibit	Diagnostic Shutdown – Auto Reset	100
Auto	Waiting For Evaporator Water Flow	58
Auto	Waiting For A Need To Cool	58
Auto	Waiting For A Need To Heat	58
Auto	Power Up Delay Inhibit: MIN:SEC	58
Waiting To Start	Waiting For Condenser Water Flow	70
Waiting To Start	Establishing Oil Pressure	70
Waiting To Start	Pre-Lubrication Time: MIN:SEC	70
Waiting To Start	Motor Temperature Inhibit: Motor Temperature / Inhibit Temperature	70
Waiting To Start	Restart Time Inhibit: MIN:SEC	70
Waiting To Start	Low Oil Temperature Inhibit: Oil Temperature / Inhibit Temperature	70
Waiting To Start	Waiting For Starter To Start: MIN:SEC	70
Starting Compressor	There is no sub mode displayed	72
Running	There is no sub mode displayed	74
Running	Surge	74
Running	Base Loaded	74
Running	Current Control Soft Loading	74
Running	Capacity Control Soft Loading	74
Running – Limit	Current Limit	75
Running – Limit	Phase Unbalance Limit	75
Running – Limit	Condenser Pressure Limit	75
Running – Limit	Evaporator Temperature Limit	75
Running – Limit	Minimum Capacity Limit	75
Running – Limit	Maximum Capacity Limit	75
Preparing To Shutdown	Closing IGV IGV Position %	7E
Shutting Down	Post-Lubrication Time: MIN:SEC	7E
Shutting Down	Evaporator Pump Off Delay: MIN:SEC	7E
Shutting Down	Condenser Pump Off Delay: MIN:SEC	7E

# Unit Control Panel (UCP)

---

## Main Screen

The main screen provides an overall view of the chiller performance in addition to the main and sub operating modes. The table below indicates other items found, when specified by options, that can be scrolled to via the up or down arrows.

## Description

Chiller Operating Mode (>>sub modes)
Evaporator Entering and Leaving Water Temperature
Condenser Entering and Leaving Water Temperature
Active Chilled Water Setpoint (>>source)
Active Current Limit Setpoint (>>source), If enabled
Active Base Loading Setpoint (>>source), If enabled
Average Line Current
Approximate Chiller Capacity, If option installed
Software Version

# Unit Control Panel (UCP)

---

## Diagnostic Screen

The **diagnostic screen** is accessible by touching the **Alarms** enunciator.

When an alarm is present, the alarm enunciator is present next to the Stop key. A flashing "alarm" indicates a machine shutdown and a non flashing "alarm" indicates an informational message.

Machine shutdowns can be of two types:

Latching (MMR) require corrective action and manual reset.

Non-Latching (MAR) will restart automatically when condition corrects itself.

Up to ten active diagnostics can be displayed if required.

The reason for all diagnostics must be determined and corrected. Do not reset and restart the chiller as this can cause a repeat failure. Contact local Trane Service for assistance as necessary.

After corrective action, the chiller can be reset or restarted. In the case of a diagnostic type, the chiller will have to be manually reset through the Diagnostics alarm menu.

When reset they become historic and viewable via the TechView™.

Performing a **Reset All Active Diagnostics** will reset all active diagnostics regardless of type, machine or refrigerant circuit.

A **Manual Override** indicator (shares space with the Alarms key) alerts the operator to the presence of a manual override. An Alarm will take precedence over the manual override, until the reset of active alarms. The manual override indicator would reappear if such an override exists.

**Temperature settings** can be expressed in F or C, depending on Display Units settings.

Dashes ("- - -") appearing in a temperature or pressure report, indicates that the value is invalid or not applicable.

The **languages** for DynaView™ will reside in the main processor. The main processor will hold three languages, English, and two alternate languages. The TechView™ will load the main processor with user selected languages from a list of available translations. Whenever possible, complete words will be used on the persistent keys as described.

# Unit Control Panel (UCP)

 Back		
Active Chilled Water Setpoint Arbitration		
Front Panel	44.0 F	Active / Blank
BAS	48.0 F / ----	Active / Blank
External	42.0 F / ----	Active / Blank
Chilled Water Reset	Return / Constant Return / Outdoor / None	
Active Chilled Water Setpoint		44.0 F
○	Auto	Stop
		●

The **active chilled water setpoint** is the setpoint that is currently in use. It will be displayed to 0.1 degrees Fahrenheit or Celsius. Touching **the double arrow** to the left of the Active Chilled Water Setpoint will take the user to the active chilled water setpoint arbitration sub-screen.

The **Active Chilled Water Setpoint** the result of arbitration between the front panel, BAS, and external setpoints.

The **chilled water reset status**, in the right most column, will display one of the following messages: Return, Constant Return, Outdoor, None

The left column text "Front Panel", "BAS", "External", "Chilled Water Reset, and "Active Chilled Water Setpoint" will always be present regardless of installation or enabling those optional items. In the second column " - - - - " will be shown if that option is Not Installed, otherwise the current setpoint from that source will be shown.

The **"Back" button** provides navigation back to the chiller screen.



# Unit Control Panel (UCP)

 Back		
Active Current Limit Setpoint Arbitration		
Front Panel	100 %	Active / Blank
BAS	80 % / ----	Active / Blank
External	70 % / ----	Active / Blank
<hr/> Active Current Limit Setpoint		100 %
○	Auto	Stop
		●

The **active current limit setpoint** is the current limit setpoint that is currently in use. It will be displayed in percent RLA. Touching the double arrow to the left of the Active Current Limit Setpoint will take the user to the active current limit setpoint sub-screen. The active current limit setpoint is that setpoint to which the unit is currently controlling. It is the result of arbitration between the front panel, BAS, and external setpoints.

# Unit Control Panel (UCP)

## Reports

Main	Reports	Settings
	Custom	▶▶
	Ashrae Guideline 3	▶▶
	Refrigerant	▶▶
	Compressor	▶▶
	Starter	▶▶
	Diagnostic History	▶▶

<input type="radio"/>	Auto	Stop	<input checked="" type="radio"/>
-----------------------	------	------	----------------------------------

Reports Evaporator Report Items	Units
Evaporator Entering Water Temperature	°C or °F
Evaporator Leaving Water Temperature	°C or °F
Evaporator Saturated Refrigerant Temperature	°C or °F
Evaporator Refrigerant Pressure	Psia or kPa
Evaporator Approach	°C or °F
Evaporator Water Flow Switch Status	Flow or No Flow

Condenser Report Items	Units
Condenser Entering Water Temperature	°C or °F
Condenser Leaving Water Temperature	°C or °F
Condenser Saturated Refrigerant Temperature	°C or °F
Evaporator Refrigerant Pressure Temperature	°C or °F
Condenser Refrigerant Pressure	Psia or kPa
Condenser Approach Temperature	°C or °F
Condenser Water Flow Switch Status	Flow or No Flow
Outdoor Air Temperature, If installed	°C or °F

# Unit Control Panel (UCP)

---

<b>Compressor Report Items</b>	<b>Units</b>
Compressor Starts:	###
Compressor Running Time:	Hour and minute
Oil Differential Pressure Switch	Open or Closed
Oil Tank Temperature	°C or °F
Vanes Position	Percent open
Vanes Position Steps	Steps

<b>Motor Report Items</b>	<b>Units</b>
Percent RLA L1 L2 L3	Percent RLA
Amps L1 L2 L3	Amps
Volts AB, BC, CA	Vac
Power Consumption, If installed	xxx kW
Load Power Factor, If installed	xx
Winding Temperature A	°C or °F
Winding Temperature B	°C or °F
Winding Temperature C	°C or °F

<b>ASHRAE Chiller Log</b>					<b>Units</b>
1. Current Time / Date	HH:MM	AM / PM	MMM	DD	YYYY
2. Chiller Mode					Stopped / Running
3. Amps	L1	L2	L3		Amps
4. Volts	AB	BC	CA		Volts
5. Active Chiller Water Set Point					F/ C
6. Active Current Limit Set Point					%
7. Refrigerant Type					134a
8. Compressor Starts					0
9. Compressor Running Time					0:00
10. Oil Tank Temperature					F/ C
11. Evaporator Entering Water Temperature					F/ C
12. Evaporator Leaving Water Temperature					F/ C
13. Evaporator Saturated Refrigerant Temperature					F/ C
14. Evaporator Saturated Refrigerant Pressure					PSIG / kPa
15. Evaporator Approach Temperature					F/ C
16. Evaporator Water Flow Switch Status					Flow / No Flow
17. Condenser Entering Water Temperature					F/ C
18. Condenser Leaving Water Temperature					F/ C
19. Condenser Saturated Refrigerant Temperature					F/ C
20. Condenser Refrigerant Pressure					PSIG / kPa
21. Condenser Approach Temperature					F/ C
22. Condenser Water Flow Switch Status					Flow / No Flow

# Unit Control Panel (UCP)

---

**Setting Tab screens** provides a user the ability to adjust settings justified to support daily tasks. The layout provides a list of sub-menus, organized by typical subsystem.

**Settings screen for standard CVGF:**

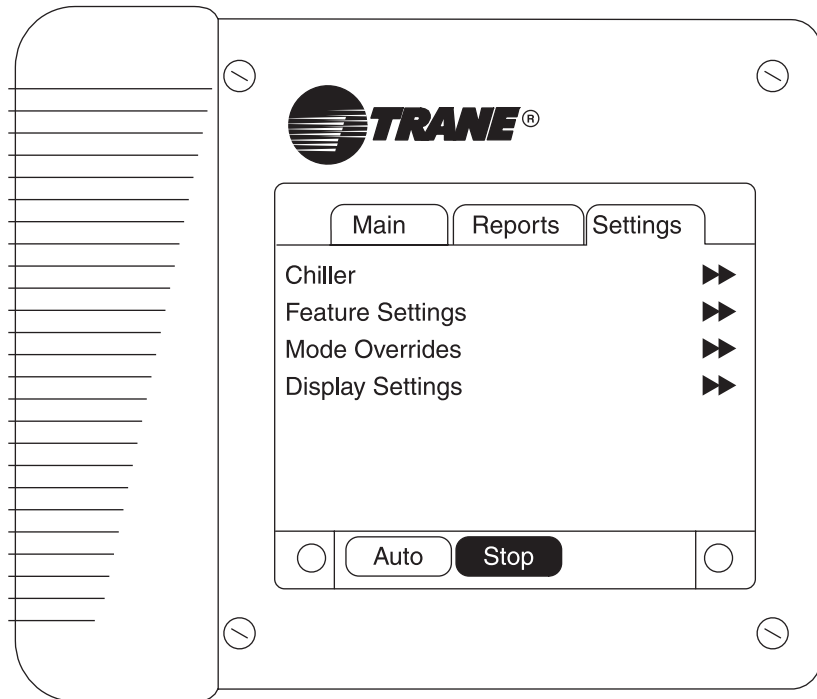

# Unit Control Panel (UCP)

---

## Chiller

Description	Units	notes
1. Front Panel Control Type	(Chilled Water, Hot Water), Chilled Water default	
2. Front Panel Chilled Water Setpoint	Temperature	1
3. Front Panel Current Limit Setpoint	Percent	2
4. Front Panel Base Load Command	On or Auto	
6. Front Panel Base Load Setpoint	Percent	
6. Differential to Start	Temperature	
7. Differential to Stop	Temperature	
8. Setpoint Source	(none, use front panel, override BAS), none default	

## Feature Settings

Description	Units
1. Chilled Water Reset	(Constant, Outdoor, Return, Disable), Disable Percent
2. Return Reset Ratio	Temperature
3. Return Start Reset	Temperature
4. Return Maximum Reset	Temperature
5. Outdoor Reset Ratio	Percent
6. Outdoor Start Reset	Temperature
7. Outdoor Maximum Reset	Temperature
8. External Chilled Water Setpoint	(Enable, Disable), Disable
9. External Current Limit Setpoint	(Enable, Disable), Disable
10. External Base Loading Setpoint	(Enable, Disable), Disable

### Notes:

1. Temperatures will be adjustable to 0.1 degree F or C. The Main Processor provides the minimum and maximum allowable value.
2. Adjustable to the nearest whole number percent. The Main Processor provides the minimum and maximum allowable value.

# Unit Control Panel (UCP)

## Mode Overrides

Description	Units	Default	Monitor Value	Notes
1. Compressor Control Signal	(Auto, Manual) [0-100]	Auto	Percent Vane Position	
			Evaporator Leaving Water Temperature	7
2. Evaporator Water Pump	(Auto, On),	Auto	1) Evaporator Flow status	
			2) Override Time Remaining	3
3. Condenser Water Pump	(Auto, On),	Auto	1) Condenser Flow status	
			2) Override Time Remaining	3
4. Oil Pump	(Auto, On),	Auto	1) Differential pressure	
			2) Override Time Remaining	3
5. Clear Restart Inhibit Timer				

## Display Settings

Description	Units	Notes
1. Date Format	("mmm dd, yyyy", "dd-mmm-yyyy"),	
2. Date	"mmm dd, yyyy"	4
3. Time Format	(12-hour, 24-hour), 12-hour	
4. Time of Day	HH:mm	4
5. Keypad and Display Lockout	(Enable, Disable), Disable	5
6. Display Units	(SI, English), English	
7. Pressure Units	Absolute / Guage	
8. Language	(English, Selection 2, Selection 3), English	6

### Notes:

- Terminates with 10 minutes if inactivity.
- The Date and Time setup screen formats deviate slightly from the standard screens defined above. See the time and date section for further details.
- Enables a DynaView™ Lockout screen. All other screens timeout in 30 minutes to this screen when enabled. The DynaView™ Lockout Screen displays a 0-9 keypad to permit the user to exit the lockout with a fixed password (1x5 x 9 + Enter). See lockout section for further details.
- Language choices are dependent on what has been setup in the Main Processor. Language selections will include English and two alternate as loaded by TechView™. Language shall always be the last setting listed on the Display Settings menu. This will allow a user to find language selection if looking at an unrecognizable language.
- Manual Compressor Control allows an operator to override the Auto Control and manually control the compressor while in operation. This is not active during Stop mode.

# Unit Control Panel (UCP)

---

Each Settings subscreen consists of a setpoints list and the current value. The operator selects a setpoint to change by touching either the description or setpoint value. Doing this causes the screen to switch to the Analog Settings subscreen shown below.

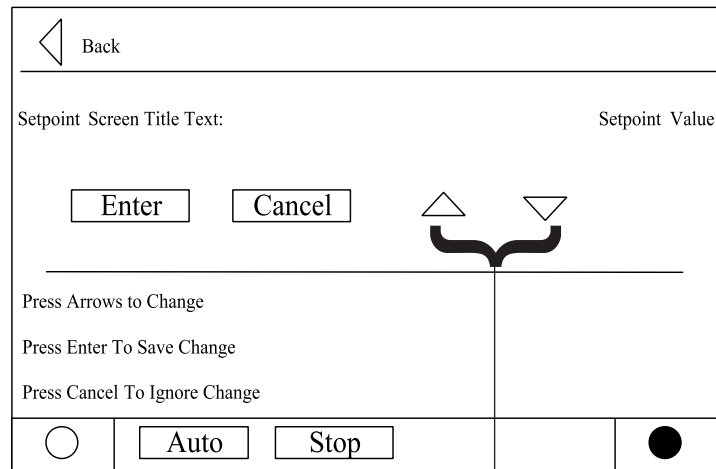

**Note:** Spin buttons used to change setpoint value.

# Unit Control Panel (UCP)

---

Settings with buttons only (screen has no cancel or enter key) do accept the new selection immediately.

**Note:** Radio 1 and Radio 2 refer to “touch sensitive buttons.” The labels depend upon the setting being controlled.

Back		
Setpoint Screen Title:	Setpoint Value	
<div style="display: flex; justify-content: space-around; margin-bottom: 10px;"> <div style="border: 1px solid black; padding: 5px 20px;">Radio 1</div> </div> <div style="display: flex; justify-content: center; margin-bottom: 10px;"> <span style="margin-right: 20px;"><i>(Button Selections)</i></span> <div style="border: 1px solid black; padding: 5px 20px;">Radio 2</div> </div> <hr style="width: 80%; margin: 0 auto;"/>		
Press Button To Select		
○	<div style="display: flex; justify-content: space-around; margin-bottom: 5px;"> <div style="border: 1px solid black; padding: 2px 10px;">Auto</div> <div style="border: 1px solid black; padding: 2px 10px;">Stop</div> </div>	●

Mode Override for Enumerated Settings is shown below:

Back		
Override Screen Title:	Setting Value	
<div style="display: flex; justify-content: space-around; margin-bottom: 10px;"> <div style="border: 1px solid black; padding: 5px 20px;">Radio 1</div> </div> <div style="display: flex; justify-content: center; margin-bottom: 10px;"> <span style="margin-right: 20px;"><i>(Button Selections)</i></span> <div style="border: 1px solid black; padding: 5px 20px;">Radio 2</div> </div> <hr style="width: 80%; margin: 0 auto;"/>		
Monitor Value Text Here <i>(Dependent on Setting )</i> <span style="float: right;">XXX.X</span>		
Press Button To Select		
○	<div style="display: flex; justify-content: space-around; margin-bottom: 5px;"> <div style="border: 1px solid black; padding: 2px 10px;">Auto</div> <div style="border: 1px solid black; padding: 2px 10px;">Stop</div> </div>	●



# Unit Control Panel (UCP)

The mode override analog setting subscreen is similar but offers an Auto or Manual radio button and value setting. An Auto or Manual selection is necessary set to the mode to override. An Enter and Cancel Key will allow the user to Enter or Cancel the entry.

Mode Override for Analog Settings is shown below:

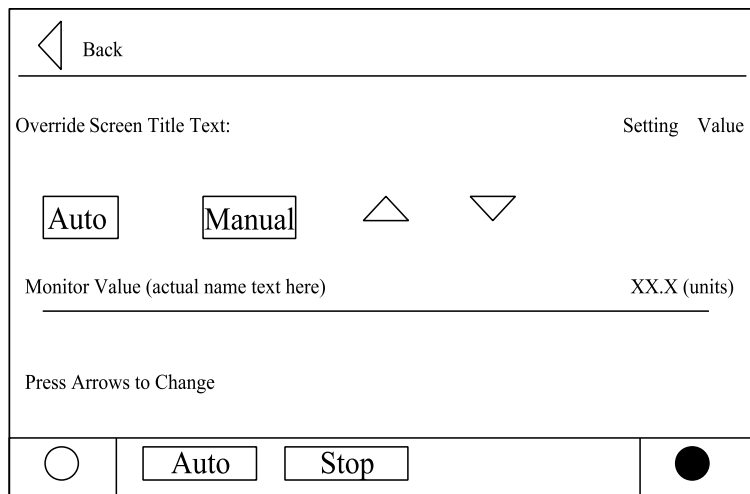

The **date setpoint screen** for setting up the is shown below: The user must select **Day, Month, or Year** and then use the up or down arrows to adjust.

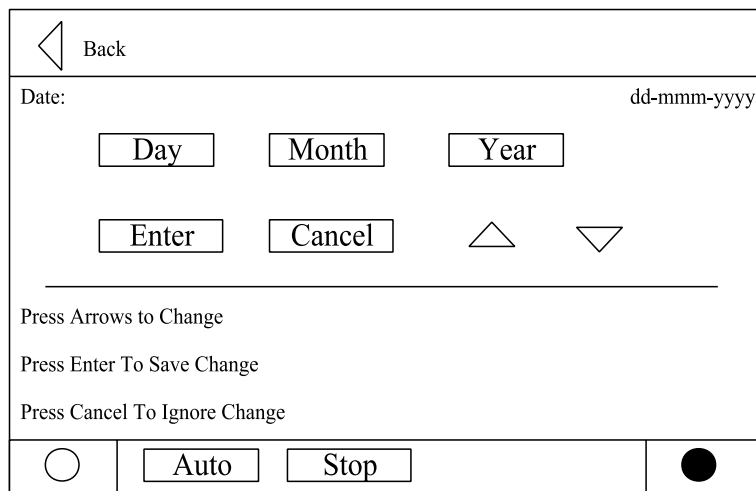

# Unit Control Panel (UCP)

---

The **time setpoint screen** with a 12 hour format is shown below: The user must select **Hour**, or **Minute** and then use the up or down arrows to adjust. Adjusting hours will also adjust am and pm.

◀ Back	
Time:	hh:mm am/pm
<input type="button" value="Hour"/>	<input type="button" value="Minute"/>
<input type="button" value="Enter"/>	<input type="button" value="Cancel"/> ▲ ▼
Press Arrows to Change	
Press Enter To Save Change	
Press Cancel To Ignore Change	
<input type="radio"/>	<input type="button" value="Auto"/> <input type="button" value="Stop"/> <input type="radio"/>

**Note:** The 24 hour format setpoint screen is similar with the am and pm not shown.

# Unit Control Panel (UCP)

The DynaView™ Display Touch Screen Lock screen is shown below. This screen is used if the Display and Touch Screen Lock feature is enabled. 30 minutes after the last key stroke this screen will be displayed and the Display and Touch Screen will be locked out until "159 Enter" is entered.

Until the proper password is entered there will be no access to the DynaView™ screens including all reports, all setpoints, Auto, Stop, Alarms, and Interlocks. The password "159" is not programmable from either DynaView™ or TechView™.

If the Display and Touch Screen Lock feature is disabled, the following screen will be automatically shown if the MP temperature is below 32°F (0°C) and it has been 30 minutes after the last key stroke. Note: the main processor is equipped with an on-board temperature sensor which enables the ice protection feature.

DISPLAY AND TOUCH SCREEN ARE LOCKED

ENTER "159 Enter" TO UNLOCK

1	2	3
4	5	6
7	8	9
Enter		Cancel

○
●

# Base Loading Control Algorithm

---

## Base Loading Control Algorithm

This feature allows an external controller to directly modulate the capacity of the chiller. It is typically used in applications where virtually infinite sources of evaporator load and condenser capacity are available and it is desirable to control the loading of the chiller. Two examples are industrial process applications and cogeneration plants.

**Industrial process** applications might use this feature to impose a specific load on the facility's electrical system.

**Cogeneration plants** might use this feature to balance the system's heating, cooling and electrical generation. All chiller safeties and adaptive control functions are in full effect when Base Loading control is enabled.

If the chiller approaches full current, the evaporator temperature drops too low, or the condenser pressure rises too high, Tracer CH530 Adaptive Control logic limits the loading of the chiller to prevent the chiller from shutting down on a safety limit. These limits may prevent the chiller from reaching the load requested by the Base Loading signal.

Base Loading Control is basically a variation of the current limit algorithm. During base loading, the leaving water control algorithm provides a load command every 5 seconds. The current limit routine may limit the loading when the current is below setpoint. When the current is within the deadband of the setpoint the current limit algorithm holds against this loading command.

If the current exceeds the setpoint, the current limit algorithm unloads.

The "Capacity Limited By High Current" message normally displayed while the current limit routine is active is suppressed while base loading.

Base loading can occur using Tracer or an external signal.

Tracer or an external signal Base Loading: Current Setpoint Range: (20 - 100) percent RLA. Base Loading requires Tracer Summit and an optional Tracer Communications Module (LLID)

# Base Loading Control Algorithm

---

## Tracer Base Loading

The Tracer commands the chiller to enter the base load mode by setting the base load mode request bit ON. If the chiller is not running, it will start regardless of the differential to start. While the unit is running in base loading, it will report that status back to the Tracer. When the Tracer removes the base load mode request, the unit will continue to run, using the normal chilled water control algorithm, and will turn off, only when the differential to stop has been satisfied.

## External Base Base Loading

The CH530 accepts 2 inputs to work with external base loading. The binary input is at 1A18 Terminals J2-1 and J2-2 (Ground) which acts as a switch closure input to enter the base loading mode. The second input, an analog input, is at 1A17 terminals J2-2 and J2-3 (Ground) which sets the external base loading setpoint, and can be controlled by either a 2-10Vdc or 4-20mA Signal. At startup the input type is configured.

The graphs in Figure 16 show the relationship between input and percent RLA. While in base loading the active current limit setpoint is set to the Tracer or external base load setpoint, providing that the base load setpoint is not equal to 0 (or out of range). If it is out of range, the front panel current limit setpoint is used. During base loading, all limits are enforced with the exception of current limit. DynaView™ displays the message "Unit is Running Base Loaded."

An alternative and less radical approach to Base Loading indirectly controls chiller capacity. Artificially load the chiller by setting the chilled water setpoint lower than it is capable of achieving. Then, modify the chiller's load by adjusting the current limit setpoint. This method provides greater safety and control stability in the operation of the chiller because it has the advantage of leaving the chilled water temperature control logic in effect.

The chilled water temperature control logic responds quicker to dramatic system changes, and can limit the chiller loading prior to reaching an Adaptive Control limit point.

# Base Loading Control Algorithm

---

Figure 16. Base loading with external mA input and with external voltage input

## Base Loading with External mA Input

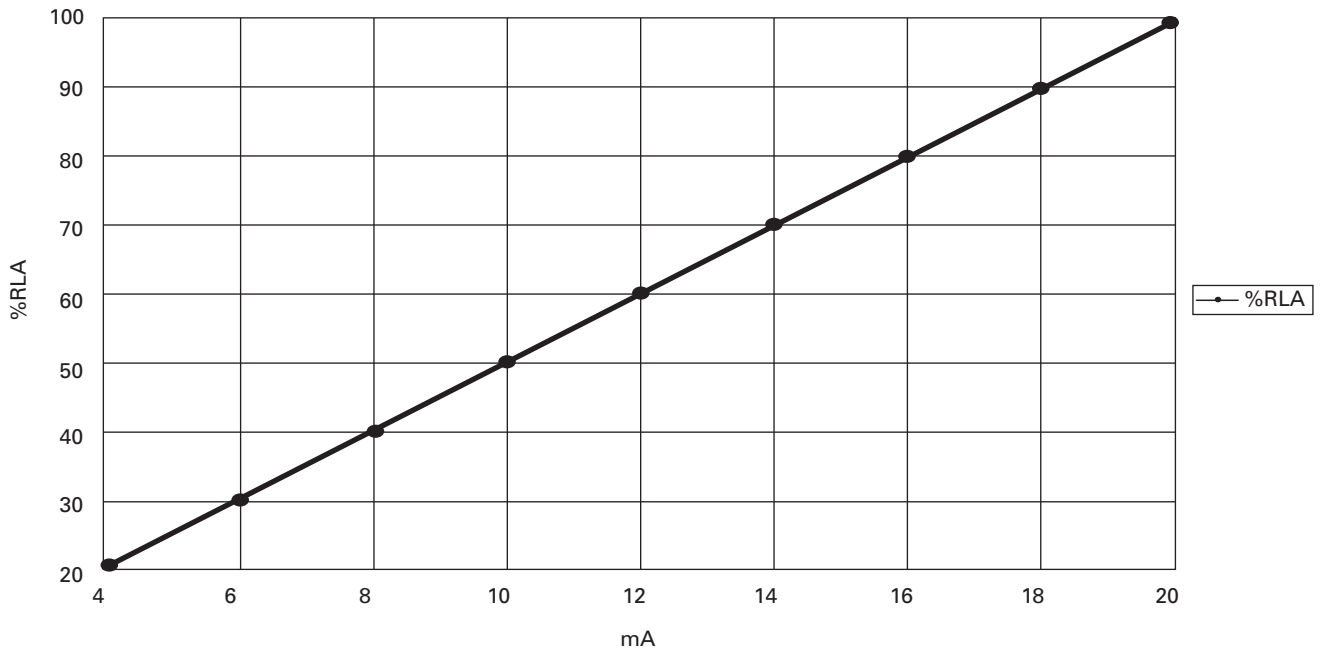

## Base Loading using External Voltage Input

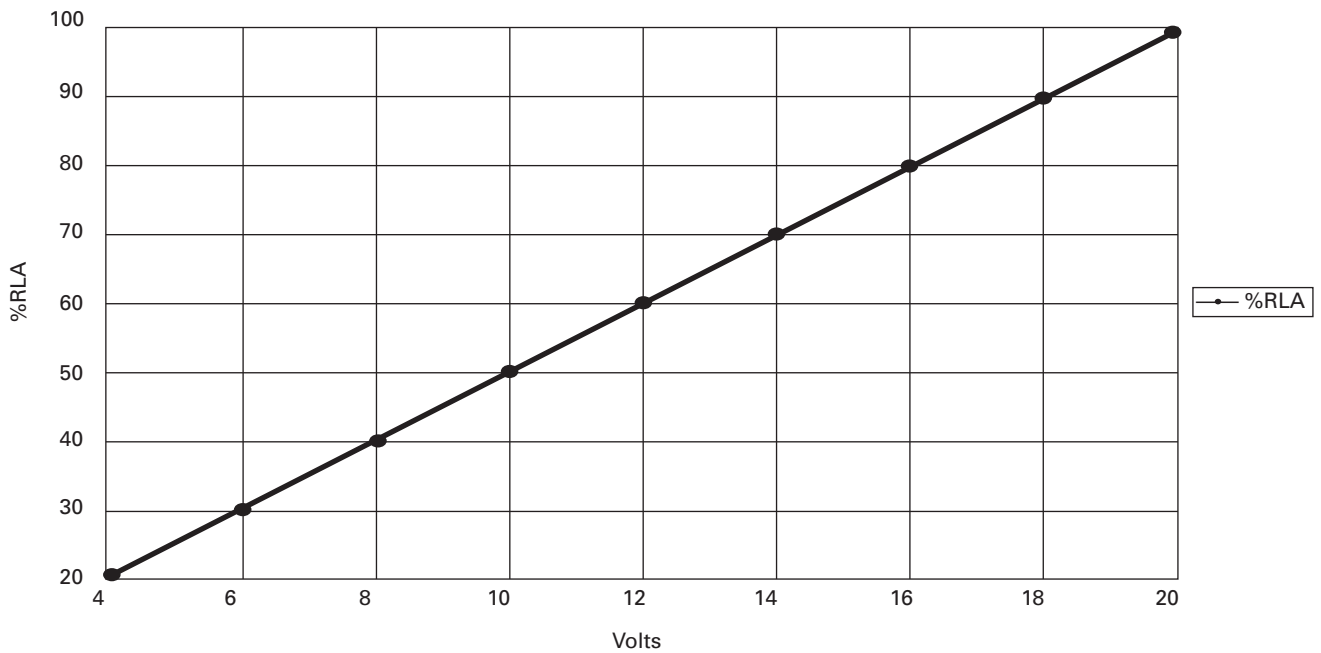

# Control System Components

## Control System Components Control Panel Internally mounted devices

For visual identification Internal Control Panel mounted devices are identified by their respective schematic designation number. Control panel items are marked on the inner back panel in the control panel (Figure 17).

The Control Panel Devices table corresponds to the same device designators. Optional controls are present when a specific optional controls package is specified. Optional controls packages are: OPST Operating Status, GBAS Generic Building Systems, EXOP Extended operation, and TRMM Tracer communications. 1A1, 1A4, 1A5, 1A6, 1A9, 1A13, 1A19, 1A26 are standard and present in all configurations. Other modules vary depending on machine optional devices.

Figure 17. Control panel components layout

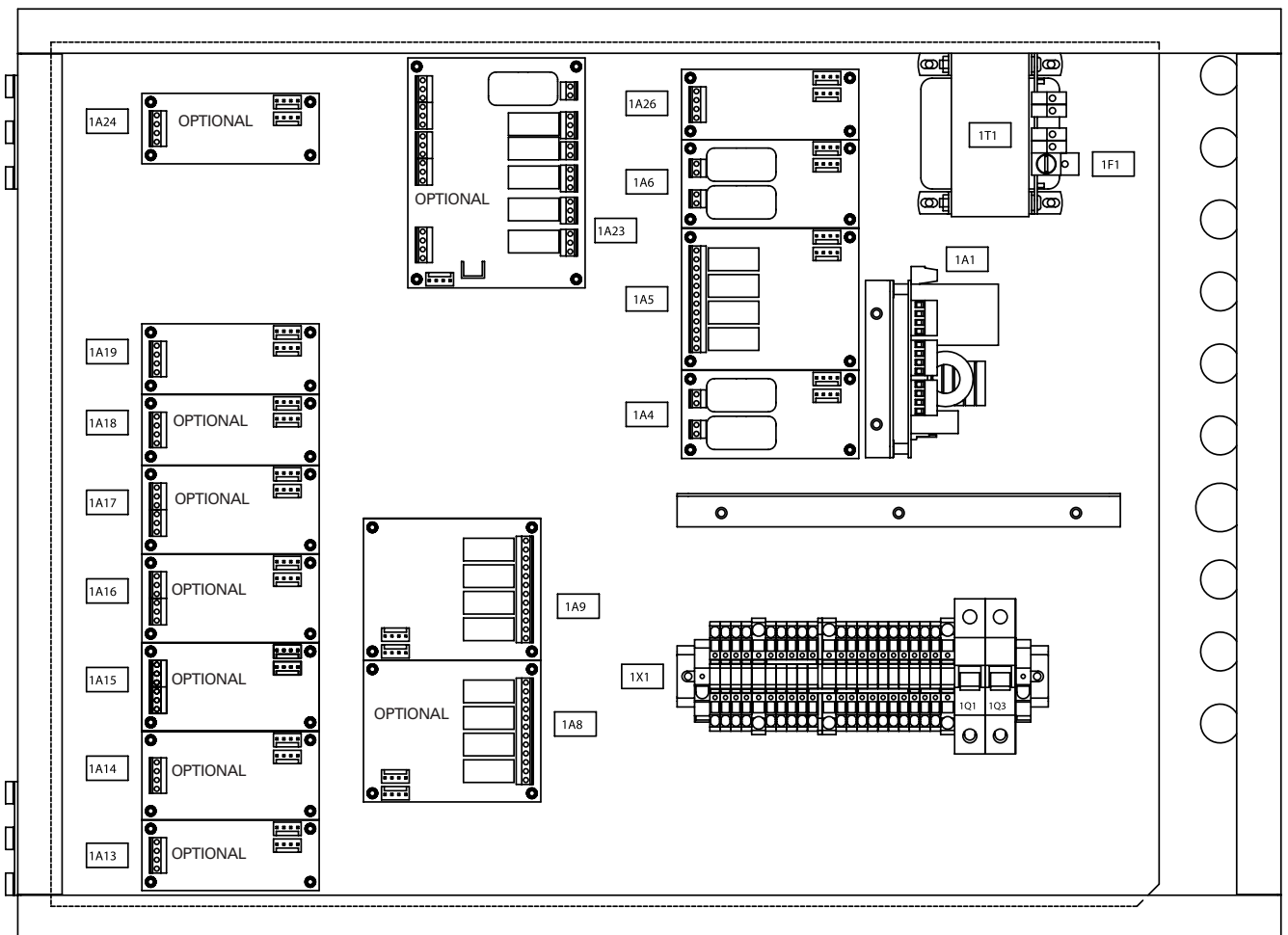

# Control System Components

---

## Chilled and Condenser Water Flow Interlock Circuits

Proof of chilled water flow for the evaporator is made by the closure of flow switch 5S1 and the closure of auxiliary contacts 5K1 on terminals 1X1-5 and 1A6-J3-1 and J3-2. Proof of condenser water flow for the condenser is made by the closure of flow switch 5S2 and the closure of auxiliary contacts 5K2 on terminals 1X1-6 and 1A6-J2-1 and J2-2.

## Head Relief Request Output

When the chiller is running in Condenser Limit Mode or in Surge Mode, the head relief request relay on the 1A9-J2-6 to J2-4 will be energized and can be used to control or signal for a reduction in the entering condenser water temperature. This is designed to prevent high refrigerant pressure trip-outs during critical periods of chiller operation.

## Maximum Capacity Relay

When the chiller has been operating at maximum capacity for over a 10 minute (TechView™ adjustable) time period this relay will activate. Also upon being less than maximum capacity for 10 minutes, this relay will deactivate. This is located at LLID 1A9-J2-1 and J2-3.

## Compressor Running Relay

Relay activates while the compressor is running.



# Control System Components

## Control Panel Devices

### Standard Devices

Description	Controls Package		Purpose	Field Connection Point Terminals
1A1 Power Supply	Standard	#1	Converts 24 vac to 24 Vdc	not for field use
1A4 Quad High Voltage Input	Standard		High Pressure Cutout	not for field use
1A5 Quad Relay Output modules	Standard	Relay #1	Chilled water pump (Relay #1)	J2-1 NO, J2-2 NC, J2-3 common
1A5 Quad Relay Output modules	Standard	Relay #2	Condenser water pump control (Relay #2)	J2-4 NO, J2-5 NC, J2-6 common
1A6 Dual High Voltage Input	Standard	Input 1	Condenser Flow Input	J3-2 Condenser water flow switch
1A6 Dual High Voltage Input	Standard	Input 2	Evaporator Flow Input	J2-2 Chilled water flow switch
1A9 Standard Quad Relay Output Status	Standard	Relay #1	Maximum Capacity Relay	J2-1 NO, J2-2 NC, J2-3 common
1A9 Standard Quad Relay Output Status	Standard	Relay #2	Head Relief Request Relay	J2-4 NO, J2-5 NC, J2-6 common
1A9 Standard Quad Relay Output Status	Standard	Relay #3	Oil Pump	J2-7 NO, J2-8 NC, J2-9 common
1A19 Standard Dual LV Binary input module	Standard	Signal #1	Oil Differential Pressure Switch	J2-3 Binary Input Signal #1, J2-4 Ground
1A13 Dual LV Binary input module	Standard	Signal #1	External Auto Stop,	J2-1 Binary Input Signal #1, J2-2 Ground
1A13 Dual LV Binary input module	Standard	Signal #2	Emergency stop	J2-3 Binary Input Signal #2, J2-4 Ground
1F1	Standard		LLID Power Supply Transformer Primary Circuit protection	not for field use
1F2	Standard		Oil Pump Motor Branch Circuit protection	not for field use
1T1	Standard		Control Panel Power Transformer ; 120:24Vac	not for field use
1Q1	Standard		Circuit Breaker Compressor Motor Controller Control Power Branch Circuit	not for field use
1Q3	Standard		Circuit Breaker – Module [-LLID] Power Supply Branch Circuit	not for field use
1X1 Terminal Block	Standard		Control Panel Terminal Block, Flow switch connections	1X1-5 Chilled water flow switch input 1X1-6 Condenser water flow switch input

# Control System Components

## OPST Operation Status Option

Relay output module 1A8 provide relay outs as shown:

1A8 Optional Quad Relay Output Status	OPST	Relay #1	MAR Alarm Relay, (Non-Latching)	J2-1 NO, J2-2 NC, J2-3 common
1A8 Optional Quad Relay Output Status	OPST	Relay #2	Limit Warning Relay,	J2-4 NO, J2-5 NC, J2-6 common
1A8 Optional Quad Relay Output Status	OPST	Relay #3	MMR Alarm Relay (Latching)	J2-7 NO, J2-8 NC, J2-9 common
1A8 Optional Quad Relay Output Status	OPST	Relay #4	Compressor running relay	J2-10 NO, J2-11 NC, J2-12 common

## EXOP Extended Operation Option

The following modules (1A17, 1A18) are provide when this control package is specified.

1A17 Optional Dual Analog Input/Output Module	EXOP	Signal #1	External Base Loading Setpoint input	J2-2 Input #1, J2-3 Ground
1A17 Optional Dual Analog Input/Output Module	EXOP	Signal #2	Refrigerant monitor inputs	J2-5 Input #2, J2-6 Ground
1A18 Optional Dual LV Binary input module	EXOP	Signal #1	External Base Loading Enable or Disable input, points	J2-1 Binary Input Signal #1, J2-2 Ground
1A18 Optional Dual LV Binary input module	EXOP	Signal #2	External Hot Water Control Enable or Disable input	J2-3 Binary Input Signal #2, J2-4 Ground

## Refrigerant Monitor Input 1A17

Analog type input 4-20ma input signal to the 1A17 J2-5 to J2-6 (ground). This represents 0-100 ppm.

## TRMM TRM4 TRM5 (Tracer Comm 4, Comm 5 interface)

1A14 Optional Communication Interface Module	TRM4 / TRM5	Tracer Communications	J2-1 COMM+, J2-2 COMM -J2-3, COMM +J2-4, COMM -,
--	-------------	-----------------------	--

## CDRP (Condenser Refrigerant Pressure Output) (1A15)

1A15 Optional Dual Analog Input/output Module	CDRP	Signal #2	Condenser Refrigerant Pressure output	J2-4 Output #2, J2-6 Ground
1A15 Optional Dual Analog Input/output Module	CDRP	Signal #1	Percent RLA Compressor Output	J2-1 Output #1, J2-3 Ground

# Control System Components

## CDRP Refrigerant Pressure Output Option 1A15:

Refrigerant Pressure Output can be configured at commissioning to correspond to either A) the absolute condenser pressure, or B) the differential pressure of the evaporator to condenser pressures.

This output is located at 1A15-J2-4(+) to J2-6 (ground)

The Output can source a maximum of 22 mA of current.

**A) Condenser Pressure Output.**  
2 to 10 Vdc corresponds to 0 Psia to the HPC (in Psia) setting.

## Temperature based

On standard machines the Percent Condenser Pressure Indication Output is based on the Saturated Condenser Refrigerant and a temperature to pressure conversion is made.

If the Condenser Saturated Temperature goes out of range due to an open or short, a pressure sensor diagnostic will be called and the output will also go to the respective out of range value. That is, for an out of range low on the sensor, the output will be limited to 2.0 Vdc. For an out of range high on the sensor, the output will be limited to 10.0 Vdc.

**Figure 18.**

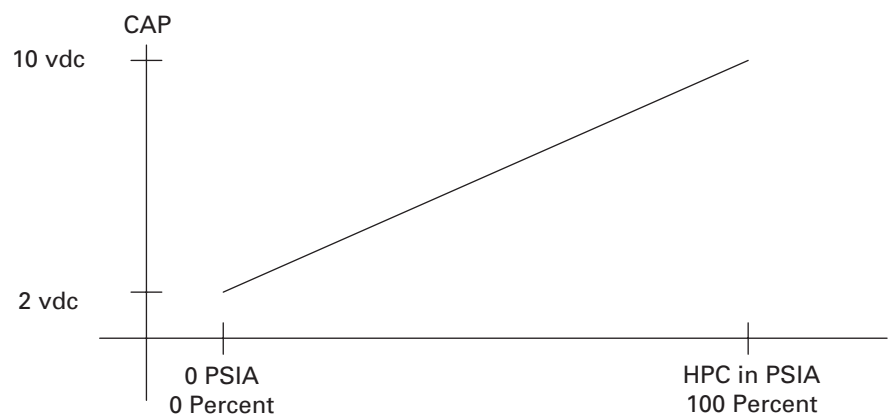

# Control System Components

## B) Refrigerant Differential Pressure Indication Output:

A 2 to 10 Vdc analog output is provided instead of the previous condenser pressure output signal. This 2 signal corresponds to a predetermined minimum and maximum pressure settings setup at commissioning of this feature. This relationship can be altered using TechView™ if required.

The “Minimum Delta Pressure” is typically set to 0 psi and will then correspond to 2 Vdc. The “Maximum Delta Pressure ” is typically set to 30 psi and corresponds to 10 Vdc.

The Minimum Delta Pressure Calibration setting has a range of 0-400 psid (0-2758 kPa) in increments of 1 psid (1kPa). The Maximum Delta Pressure Calibration setting has a range of 1-400 psid (7-2758 kPa) in increments of 1 psid (1kPa). The condenser refrigerant pressure is based on the Condenser Refrigerant Temperature sensor. The evaporator refrigerant pressure is based on the Saturated Evaporator Refrigerant Temperature Sensor.

**Figure 19. Delta pressure setting**

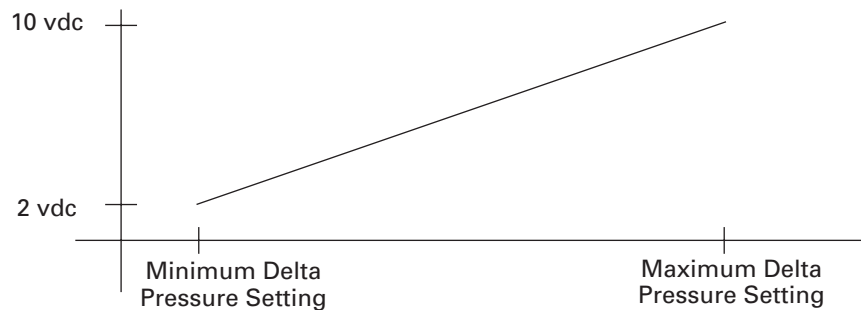

# Control System Components

## GBAS (Generic Building Automation System)

1A15 Optional Dual Analog Input/output Module	GBAS	Signal #1	Percent RLA Compressor Output	J2-1 Output #1, J2-3 Ground
1A15 Optional Dual Analog Input/output Module	GBAS	Signal #2	Condenser Refrigerant Pressure or Evaporator/Condenser differential	J2-4 Input #2, J2-6 Ground
1A16 Optional Dual Analog Input/output Module	GBAS	Signal #1	Chilled Water Reset input, or External Chiller Water Setpoint	J2-2 Input #1, J2-3 Ground
1A16 Optional Dual Analog Input/output Module	GBAS	Signal #2	External Current limit Setpoint	J2-5 Input #2, J2-6 Ground

### Percent RLA Output

2 to 10 Vdc corresponding to 0 to 120% RLA. With a resolution of 0.146%. The Percent RLA Output is polarity sensitive.

The following graph illustrates the output:

**Figure 20. Voltage versus percent RLA**

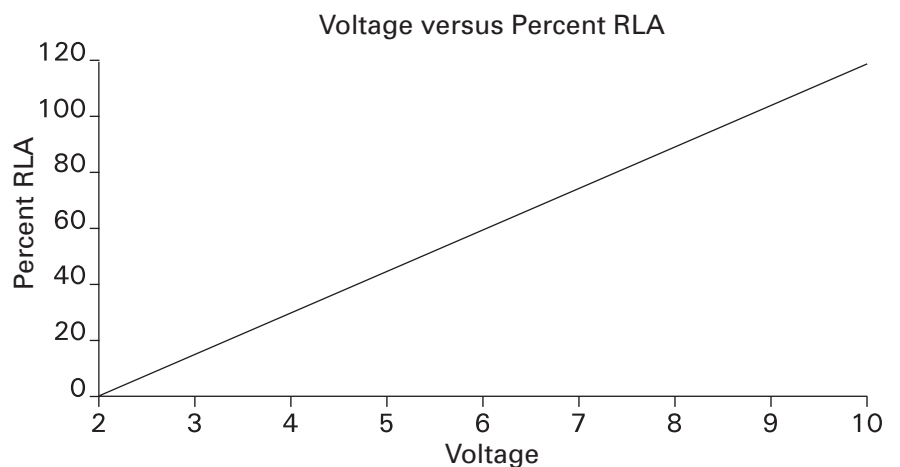

# Control System Components

---

## **External Chilled Water Setpoint (ECWS)**

The External Chilled Water Setpoint allows the chilled water setpoint to be changed from a remote location. The External Chilled Water Setpoint is found on 1A16 J2-2 to J2-3 (ground). 2-10 Vdc and 4-20 mA correspond to a 0 to 65°F (-17.8 to 18.3°C) CWS range.

## **External Current Limit Setpoint**

The External Current Limit is an option that allows the current limit setpoint to be changed from a remote location. The External Limit Setpoint is found on 1A16 J2-5 to J2-6 (ground), 2-10 Vdc and 4-20 mA each correspond to a 40 to 120 percent RLA range. CH530 limits the maximum ECLS to 100 percent.

## **Module Characteristics**

### **1A1, Power Supply :**

Unit Control Power Supply  
Module Converts 27 Vac to 24 Vdc.

Power Input Voltage: 23VRMS minimum, 27VRMS Nominal, 30VRMS maximum

Frequency: 50-60 Hz

Current: Full load 27 Vac – 4.30 A (RMS)

Inrush 27 Vac (RMS) ~ 30A (RMS)

Power Output: Class II Voltage 24 Vdc, Rated Current 2.44 Amps.

### **1A4, 1A6, Dual high Voltage Binary input module:**

Binary Input Signal #1 J2-1 to 2

Binary Input Signal #2 J3-1 to 2

High Voltage Binary Input: Off Voltage: 0 to 40 Vac RMS , On Voltage: 70 to 276 Vac RMS

Input is not polarity sensitive (Hot and neutral can be switched), Input impedance 130K to 280K ohms

14-26 AWG with a maximum of two 14 AWG

Power, 24 +/- 10 percent Vdc, 20 mA maximum. Trane IPC3 protocol. J1-1 +24Vdc, J1-2 Ground, J1-3 COMM +, J1-4 COMM -

# Control System Components

---

## **1A5, 1A8, 1A9 Quad Relay Output Status:**

Relay #1 J2-1 NO, J2-2 NC, J2-3 common

Relay #2 J2-4 NO, J2-5 NC, J2-6 common

Relay #3 J2-7 NO, J2-8 NC, J2-9 common

Relay #4 J2-10 NO, J2-11 NC, J2-12 common

Relay Outputs: at 120 Vac: 7.2 Amps resistive, 2.88 Amps pilot duty, 1/3 HP, 7.2 FLA, at 240 Vac: 5 Amps general purpose 14-26 AWG, two 14 AWG Maximum Power, 24

±10 percent Vdc, 100 mA maximum. Trane IPC3 protocol.

## **1A13, 1A18, 1A19, 1A24 Dual Binary input module:**

J2-1 Binary Input Signal #1, J2-2 Ground, J2-3 Binary Input Signal #2, J2-4 Ground

Binary Input: Looks for a dry contact closure. Low Voltage 24V 12 mA.

14 - 26 AWG with a maximum of two 14 AWG

Power, 24 +/- 10 percent Vdc, 40 mA maximum Trane IPC3 protocol.

## **1A14 Communication interface Module**

Power, 24 ± 10 percent Vdc, 50 mA maximum. Trane IPC3 protocol.

### ***1A14 Communication Polarity***

J1-1	+24 Vdc	J2-1 COMM +.	J11-1+24 Vdc
J1-2	Ground	J2-2 COMM -	J11-2 Ground
J1-3	COMM +	J2-3 COMM +	J11-3 COMM +
J1-4	COMM -	J2-4 COMM -	J11-4 COMM

# Control System Components

---

## 1A15, 1A16, 1A17, Dual Analog Input/output Module;

Analog Output: The Analog Output is a voltage only signal. 2-10 Vdc at 22mA

J2: 14 - 26 AWG with a maximum of two 14 AWG

J2-1 Output #1 to J2-3 (ground), J2-4 Output #2 to J2-6 (ground).

CH530 provides a 2-10 Vdc analog signals as Outputs. The Output's maximum source capability is 22mA. The maximum recommended length to run this signal is included in the table below.

## Analog Input:

The analog input can be software switched between a voltage input or a current input. When used as a current input a 200 Ohm load resistor is switched in.

**0-12 Vdc or 0-24 mA Analog Inputs**  
CH530 accepts either a 2-10 Vdc or 4-20 analog input suitable for customer external control. The type is determined at unit commissioning during feature installation.

J2: 14-26 AWG with a maximum of two 14 AWG

J2-2 Input #1 to

J2-3 (ground).

J2-5 Input #2 to

J2-6 (ground).

Power, 24 +/- 10 percent Vdc, 60 mA maximum, Trane IPC3 protocol.

### Maximum Length to Run external Output signals

Gauge	Ohms per Foot	Length (Feet)	Length (Meters)
14	0.002823	1062.7	324
16	0.004489	668.3	203.8
18	0.007138	420.3	128.1
20	0.01135	264.3	80.6
22	0.01805	166.3	50.7
24	0.0287	104.5	31.9
26	0.04563	65.7	20
28	0.07255	41.4	12.6

Note: the above table is for copper conductors only.



# Control System Components

---

*Note: If the chiller is operating in a limit mode (current limit, condenser limit, evaporator limit, and so forth), the limit operation has priority over all DynaView™ manual modes of operation.*

On each CH530 power-up, the inlet guide vanes are driven full closed to recalibrate the zero position (steps) of the Stepper motor vane actuator.

## **Motor Temperature Sensor Module**

The motor temperature module 1A26 connects using unit wiring to the three motor winding temperature sensors. This module is located in the control panel where the module is connected to the IPC bus.

## **Temperature Sensors**

Evaporator entering 4R6  
Evaporator leaving 4R7  
Condenser entering 4R8  
Condenser leaving 4R9  
Oil temperature 4R5  
Outdoor air 4R13  
Evaporator saturated refrigerant 4R10  
Condenser saturated refrigerant 4R11  
Probe Operating Temperature Range -40 to 121°C  
Accuracy ± 0.250°C over the range - 20 to 50°C ± 0.50°C over the range -40 to 121°C

## **Starter Module**

In the hierarchy of modules the Starter module 2A1 (1A23 when customer-supplied starter specified) is second only to the DynaView™.

The starter module is present in all starter selections. This includes Wye Delta, Across the Line, and Solid State whether remote unit mounted or supplied by others. The starter module provides the logic to provide the motor protection for current overload, phase reversal, phase loss, phase imbalance, and momentary power loss.

# Control System Components

---

## Electrical Sequence

This section will acquaint the operator with the control logic governing chillers equipped with Tracer CH530 control systems.

**Note:** The typical wiring diagrams are representative of standard units and are provided only for general reference. They may not reflect the actual wiring of your unit. For specific electrical schematic and connection information, always refer to the wiring diagrams that shipped with the chiller.

With the supply power disconnect switch or circuit breaker (2Q1 or 2K3) on, 115-volt control power transformer 2T5 and a 15-amp starter panel fuse (2F4 ) to terminal (2X1-1) starter panel to terminal 1X1-1 in the control panel. From this point, control voltage flows to:

1. Circuit Breaker 1Q1 which provides power to the starter module (2A1) relay outputs and the High Pressure Cutout switch (4S1).
2. Circuit Breaker 1Q3 which provides power to Transformer (1T1) which steps down the 115 Vac to 24 Vac. This 24 Vac then powers the 24 Vdc power supply 1A1, and 1A2 if present. The 24 Vdc is then connected to all modules using the IPC Bus providing module power. 1Q3 also provides power to the external chiller water proof of flow device connected between terminal block 1X1-5 to 1A6-J3-2, and condenser water proof of flow device connected at 1X1-6 to 1A6-J2-2.
3. The DynaView™ display module 1A22, receives 24 Vdc power from the IPC bus.

# Control System Components

---

## CH530 and Wye-Delta Starter Control Circuits (Sequence of Operation)

Logic Circuits within the various modules will determine the starting, running, and stopping operation of the chiller. When operation of the chiller is required the chiller mode is set at "Auto." Using customer-supplied power, the chilled water pump relay (5K1) is energized by the 1A5 Module output at 1A5-J2-4, and chilled water flow must be verified within 4 minutes 15 seconds by the 1A6 module. The main processors logic decides to start the chiller based on the differential to start setpoint. With the differential to start criteria met module 1A5 then energizes the condenser water pump relay (5K2) using customer-supplied power at 1A5 J2-1.

Based on the restart inhibit function and the differential to start setpoint, oil pump (4M3) will be energized by 1A9 module (1A9-J2-7). The oil pressure switch must be closed for 30 continuous seconds and condenser water flow verified within 4 minutes 15 seconds for the compressor start sequence to be initiated.

When less than 5 seconds remain before compressor start, a starter test is conducted to verify contactor state prior to starting the compressor. The following test or start sequence is conducted for "Wye-Delta" starters:

1. Test for transition complete contact open (1A23X or 2A1-J12-2) –160 to 240 msec. An MMR diagnostic will be generated if the contact is closed.
2. Delay time - 20 msec.
3. Close start contactor (2K1) and check for no current - 500 msec. If currents are detected, the MMR diagnostic "Starter Fault Type I" is generated and closes for one second.
4. Delay time - 200 msec. (Opens 2K1).
5. Close shorting contactor, (2K3) and check for no current (1A23 or 2A1 J4-1) for one second. If currents are detected the MMR diagnostic "Starter Fault Type II" is generated. (Starter Integrity test)
6. If no diagnostics are generated in the above tests, the stop relay (2A1- J10) is closed for two seconds and the start relay (2A1-J8) is closed to energize the start contactor (2K1).

# Control System Components

---

The shorting contactor (2K3) has already been energized from (F) above. The compressor motor (4M1) starts in the "Wye" configuration, an auxiliary contact (2K1-AUX) locks in the start contactor (2K1) coil.

7. After the compressor motor has accelerated and the maximum phase current has dropped below 85 percent of the chiller nameplate RLA for 1.5 seconds, the starter transition to the "Delta" configuration is initiated.
8. The transition contactor (2K4) is closed through relay 2A1-J2, placing the transition resistors (2R1, 2R2, and 2R3) in parallel with the compressor motor windings.
9. The shorting contactor (2K3) is opened through the opening of relay 2A1-J4 100 msec after the closure of the transition relay 2A1-J2.

10. The run contactor (2K2) is closed through relay 2A1-J6, shorting out the transition resistors 260 milliseconds after the opening of the shorting relay 2A1-J4. This places the compressor motor in the "Delta" configuration and the starter module waits to look for this transition for 2.35 seconds through the closure of the transition complete contacts 2K2- AUX at module 2A1-J12 input.
11. The starter module must now confirm closure of the transition complete contact (2K2- AUX) within 2.32 to 2.38 seconds after the run relay (2A1-J6) is closed. Finally, the transition relay (2A1-J2) is opened de-energizing the transition contactor (2K4) and the compressor motor starting sequence is complete.

An MMR diagnostic will be generated if the transition complete contacts (2K2-AUX) do not close.

Now that the compressor motor (4M1) is running in the "Delta" configuration, the inlet guide vanes will modulate, opening and closing to the chiller load variation by operation of the stepper vane motor actuator (4M2) to satisfy chilled water setpoint. The chiller continues to run in its appropriate mode of operation: Normal, Softload, Limit Mode, and so forth

# Control System Components

---

If the chilled water temperature drops below the chilled water set point by an amount set as the "differential to stop" setpoint, a normal chiller stop sequence is initiated as follows:

1. The inlet guide vanes are driven closed for 50 seconds.
2. After the 50 seconds has elapsed, the stop relay (2A1-J10) and the condenser water pump relays (1A5-J2) open to turn off. The oil pump motor (4B3) will continue to run for 1 minute post-lube while the compressor coasts to a stop. The chilled water pump will continue to run while the Main processor module (1A22) monitors leaving chilled water temperature preparing for the next compressor motor start based on the "differential to start" setpoint.

If the <STOP> key is pressed on the operator interface, the chiller will follow the same stop sequence as above except the chilled water pump relay (1A5-J2) will also open and stop the chilled water pump after the chilled water pump delay timer has timed out after compressor shut down.

If the "Immediate Stop" is initiated, a panic stop occurs which follows the same stop sequence as pressing the <STOP> key once except the inlet guide vanes are not sequence closed and the compressor motor is immediately turned off.

# Machine Protection and Adaptive

---

## Machine Protection and Adaptive Control

### Momentary Power Loss (MPL) Protection

Momentary power loss detects the existence of a power loss to the compressor motor and responds by initiating the disconnection of the compressor motor from the power source.

Power interruptions of less than 30 line-cycles are defined as momentary power losses. Tests have shown that these short-term power interruptions can be damaging to the motor and compressor if the chiller is reconnected to the line while the motor and line phases do not match. The chiller will be shut down when a MPL is detected and will display a non-latching diagnostic indicating the failure.

The oil pump will be run for the post-lube time period when power returns. The compressor and compressor motor are protected from damage from large torques and inrush currents resulting from reconnecting the compressor motor to the power source following a momentary loss of power.

MPLs greater than 2 or 3 cycles are detected resulting in unit shut down. Disconnection from the line is initiated within 6 line-cycles of the power loss. MPL protection is active anytime the compressor is in the running mode. (The transition complete input has been satisfied.)

**Note:** MPL is defaulted to enabled however can be disabled, if required using TechView™.

# Machine Protection and Adaptive

Figure 21. CVGF sequence of operation: momentary power loss, (DynaView™ and starter module remain powered)

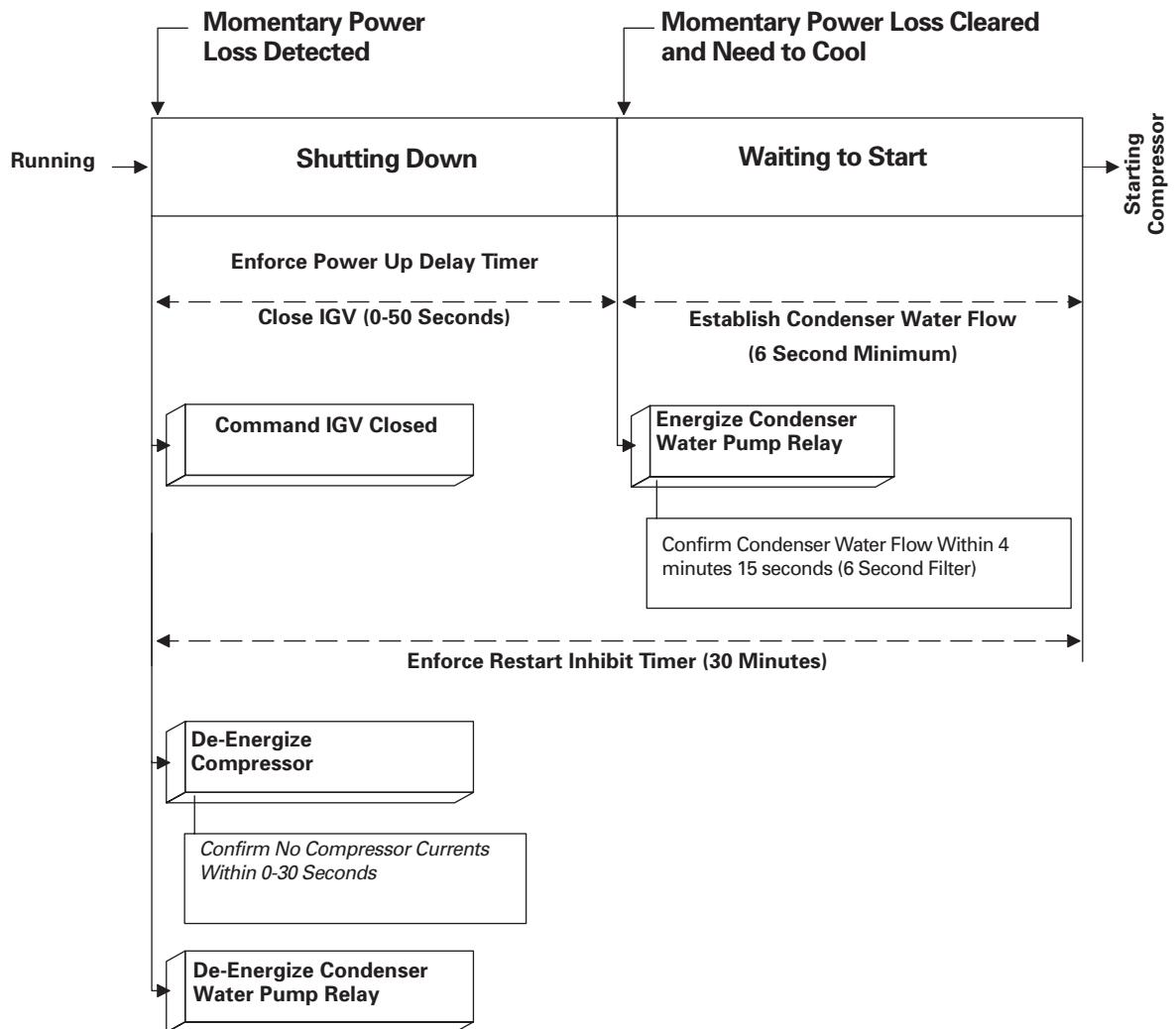

# Machine Protection and Adaptive

## Current Overload Protection

Motor currents are continuously monitored for over current protection and locked rotor protection. This protects the chiller from damage due to current overload during starting and running modes but is allowed to reach full load amps. This overload protection logic is independent of the current limit. The overload protection will ultimately shut the unit down anytime the highest of the three phase currents exceeds the time trip curve. A manual reset diagnostic describing the failure will be displayed.

Overload protection for the motor starts based on the maximum time to transition permitted for a particular motor.

## Running Overload Protection

In the run mode, a time trip curve is looked at to determine if a diagnostic should be called. The starter LLID continuously monitors compressor line currents to provide running overload and locked rotor protection.

Overload protection is based on the line with the highest current. It triggers a manually resettable diagnostic shutting down the compressor when the current exceeds the specified time trip curve. The compressor overload time trip curve is expressed as a percent of the RLA of the compressor and is not adjustable:

Overload Must Hold = 102 Percent RLA.

Overload Must Trip in 20 (+0 -3) seconds = 112 Percent RLA

(Note the above gives a nominal 20 seconds must trip point of 107 Percent RLA.)

Overload Must Trip in 1.5 seconds = 140 Percent RLA (Nominal)

The time trip curve is as follows:

**Figure 22. Overload time trip versus percent RLA**

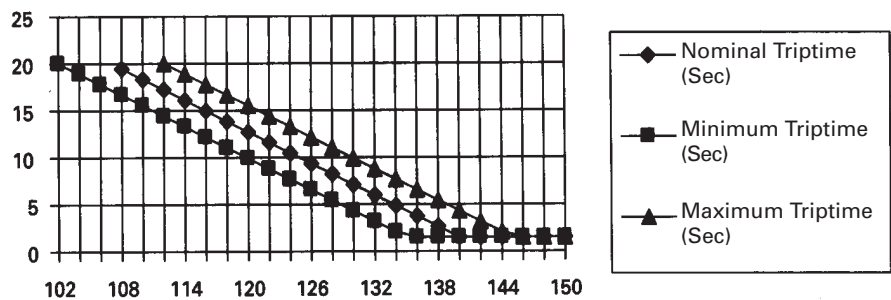



# Machine Protection and Adaptive

---

## Current Limit Protection

Current Limit Protections exist to avoid motor current overload and damage to the compressor motor during starting and running.

The Current Limit Setpoint (CLS) can be changed from: Front Panel, External Analog input (with GBAS option), or Tracer (Tracer option). Tracer current setpoint has the highest priority, unless disabled in the DynaView™ Setpoint source override menu. The External CLS has second priority, and will be used if Tracer is disabled or not installed. The Front Panel Setpoint has the lowest priority, and will be used if Tracer and the External CLS are both disabled.

Compressor motor current is continuously monitored and current is controlled using a limit function to prevent running into overload diagnostic trips. The current limit control logic attempts to prevent the motor from shutting down on a diagnostic trip by limiting compressor current draw relative to an adjustable current limit DynaView™ CLS.

This setpoint can also be lowered to provide electrical demand limiting on the unit as required. This could also be set to allow the chiller to continue to run at a lower load to avoid tripping off using a diagnostic.

The Current Limit function uses a PID algorithm (similar to the Leaving Water Temperature control) that allows the chiller to run at the CLS. At machine startup, or with any setpoint change the new current limit setpoint reached after the filtered setpoint time elapses. The minimum current limit setpoint is default set to 40 percent RLA (20-100 percent). The filtering time default is set to 10 minutes (0-120 minutes); however these can be altered using the TechView™. This filtered setpoint allows for stable control if the Current Limit setpoint is adjusted during a run.

## Phase Loss Protection

Loss of phase detection protects the chiller motor from damage due to a single-phasing condition. The controls will shut down the chiller if any of the three phase currents feeding the motor are lost. The shutdown will result in a latching diagnostic indicating the failure.

## Reverse Rotation Protection

This function protects the compressor from damage caused by being driven in the reverse direction. Incorrect phase rotation detection results in a manually resettable diagnostic. Phase Reversal protection default is set to enable, however can be disabled using TechView™.

# Machine Protection and Adaptive

---

## Differential to Start or Stop

The Differential to Start setpoint is adjustable from 1 to 10°F (0.55 to 5.5°C) and the Differential to Stop setpoint adjustable from 1 to 10°F (0.55 to 5.5°C). Both setpoints are with respect to the Active Chilled Water Setpoint. When the chiller is running and the Leaving Water Temperature (LWT) reaches the Differential to Stop setpoint the chiller will go through its shutdown sequence to Auto. Reference Figure 10.

## SoftLoading

Softloading stabilizes the startup control during the initial chiller pulldown. Soft loading is used to bring the building loop temperature from its start value to the Chilled Water or Hot Water Setpoint in a controlled manner. Without soft loading, the chiller controls will load the chiller rapidly and use the full chiller capacity to bring the loop temperature to setpoint. Although the start temperature of loop may have been high, the actual system load may be low. Thus, when the setpoint is met the chiller must unload quickly to the system load value. If it is not able to unload quickly enough, the supply water temperature will drop below setpoint and may even cause the chiller to cycle off. Soft loading prevents the chiller from going to full capacity during the pulldown period. After the compressor has been started, the starting point of the filtered setpoint is initialized to the value of the Evaporator Leaving Water temperature and the percent RLA.

There are three independent Softload setpoints:

- Capacity Control Softload Time default is to 10 minutes and settable from 0-120 minutes. This setting controls the time constant of the Filtered Chilled Water Setpoint.
- Current Limit Control Softload Time default is 10 minutes and settable from 0-120 minutes. This setting controls the time constant of the Filtered Current Limit Setpoint.
- Current Limit Softload Starting Percent default is 40 percent RLA and settable from 20-100 percent. This setting controls the Starting point of the Filtered Current Limit Setpoint.

**Note:** TechView™ provides access to these three setpoints.

## Minimum and Maximum Capacity Limit

A Minimum Capacity can be set to limit the unloading ability of the compressor forcing differential stop to be reached cycling the chillers. Minimum capacity limit will be displayed when in this limit mode. This indicates when the chiller is running fully unloaded. Similarly a maximum capacity can be set to limit normal chilled water temperature control. The maximum capacity relay is energized which is a signal used by generic BAS systems to start another chiller.

The minimum (default at 0 percent) and maximum (default at 100 percent) capacity are adjustable using TechView™.

# Machine Protection and Adaptive

---

## Evaporator Limit

Evaporator refrigerant temperature is continuously monitored to provide a limit function that prevents low refrigerant temperature trips. This allows the chiller to continue to run at a reduced load instead of tripping off at the Low Refrigerant Temperature Cutout Setpoint (LRTC).

Evaporator limit could occur with an initial pulldown of a loop temperature where the condenser is colder than the evaporator (inverted start), and the evaporator refrigerant temperature may drop below the LRTC. This limit prevents the unit from shutting down on a diagnostic during this type of pulldown. Another example is a chiller that is low on refrigerant charge. It will run with low evaporator refrigerant temperatures. This limit allows the chiller to continue to run at a reduced load.

Evaporator Limit uses the Evaporator Refrigerant Temperature sensor in a PID algorithm (similar to the Leaving Water Temperature control) that allows the chiller to run at the LRTC + 2 degree F (1.1°C).

When actively limiting machine control "Evaporator Temperature Limit" will be displayed as a suboperating mode.

## Leaving Water Temperature Cut-out

Leaving water temperature cutout is a safety control that protects the chiller from damage caused by water freezing in the evaporator. The cutout setpoint is factory set at 36°F (2.2°C) however is adjustable with TechView™. The cut-out strategy is illustrated in Figure 23.

The Leaving Water Temperature Cut-out Setpoint is independently adjustable from the chilled water setpoint. Shutdown of the compressor due to violation of the Leaving Water Temperature Cut-out results in an automatically resettable diagnostic (MAR). The DynaView™ Operating Mode indicates when the Leaving Water Temperature Cut-out Setpoint conflicts with the chilled water temperature setpoint by a message on the display. The Leaving Water Temperature Cutout Setpoint and chilled water setpoint, both active and front panel, are separated by a minimum of 1.7°F (0.94°C). (See Cut-out Strategy Figure 23.) When either difference is violated, the CH530 does not permit the above differences to be violated and the display exhibits a message to that effect and remains at the last valid setpoint. After violation of the Leaving Water Temperature Cut-out Setpoint for 30°F (16.7°C) seconds the chiller will shutdown and indicate a diagnostic.

## Low Refrigerant Temperature Cut-out

The purpose of the low evaporator refrigerant temperature protection is to prevent water in the evaporator from freezing. When the LRTC trip point is violated, a latching diagnostic indicating the condition is displayed. The LRTC Diagnostic is active in both the Running and Stopped modes.

# Machine Protection and Adaptive

**Figure 23. Cutout strategy**

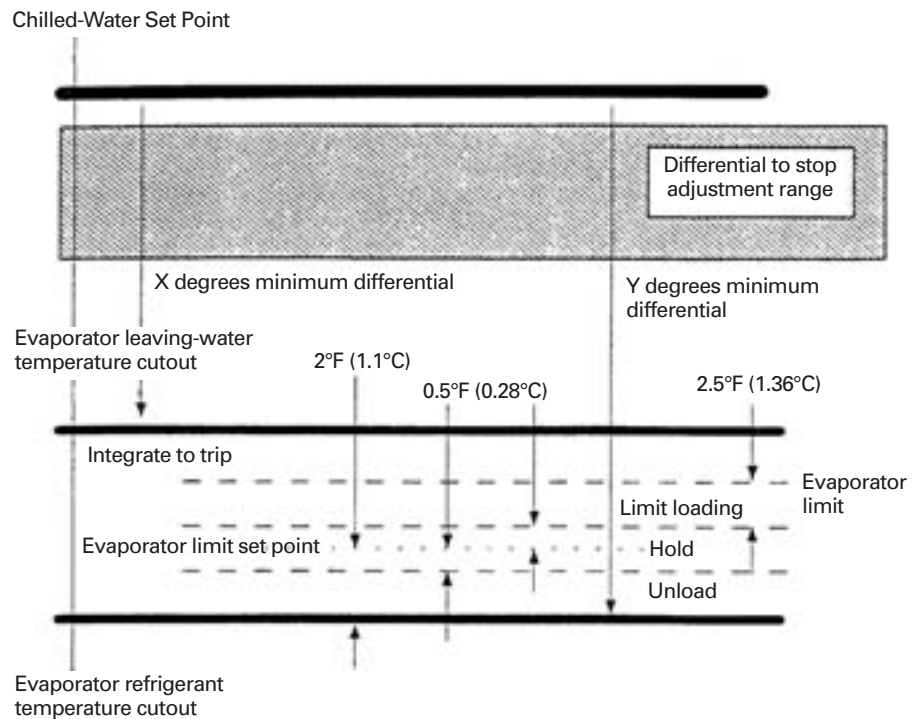

## Condenser Limit

Condenser pressure is continuously monitored to provide a limit function that prevents High Pressure Cutout (HPC) trips. This protection is called Condenser Refrigerant Pressure Limit, or High Pressure Limit. A fully loaded compressor, operating at high Evaporator Leaving Water Temperature (ELWT) and high condenser temperatures causes high condenser pressures. The purpose of this limit is to avoid HPC trips by allowing the chiller to continue to run at a lower load instead of tripping off using HPC.

The Condenser Limit will be based on a pressure conversion from the Condenser Refrigerant Temperature sensor. When limited by this action, "Condenser Pressure Limit" will be displayed as a sub-operating mode.

The Condenser Limit Setpoint is factory set (93 percent of HPC), however can be changed using TechView™.

# Machine Protection and Adaptive

---

## Restart Inhibit

This function provides short cycle protection for the motor, and indirectly also short cycling protection for the starter since the starter is designed to operate the motor under all the conditions of motor performance.

### Restart Inhibit Function Using Time Base

This method uses straight start-to-start timer to determine when to allow the next start. A Restart Inhibit Start-to-Start Time setpoint is used to set the desired start-to-start time.

Default is 20 minutes and can be altered using the TechView™. A time based restart inhibit function is used if the Restart Inhibit Type is set to 'Time' using TechView™ or if the motor winding temperatures are determined to be invalid.

**Note:** When the start is inhibited by the restart inhibit function, the time remaining will be displayed along with the restart inhibit mode. There is no 'free' start on a power up of the MP since a real time clock is used to determine when the next start will be allowed based on the start time of the previous start.

### Low Oil Temperature Start Inhibit

When oil temperature is at or below the low oil temperature start inhibit setpoint (80-140°F/26.7-60°C), the heater is energized to raise the oil temperature.

Low oil temperature is indicative of refrigerant dilution in the oil. Oil temperature is used to estimate this dilution since the oil temperature directly corresponds to amount of refrigerant dilution in the oil. It is required that oil contains minimal refrigerant in it. This is accomplished by boiling the refrigerant out of the oil by maintaining a high enough oil temperature.

If enhanced oil temperature protection is disabled or below a given Low Oil Temperature Inhibit setting (default 95°F/35°C) the compressor cannot be started. This is an inhibit mode and will be reported to the operator interface.

The oil heater is energized in an attempt to raise the oil temperature over this inhibit temperature setpoint. The compressor is inhibited from starting until the oil temperature is raised 5°F (2.7°C) or more degrees above this setpoint.

The Low Oil Temperature Start Inhibit is tested on every start unless a quick restart is being performed during post-lube.

If the Enhanced Oil Temperature Protection setting is enabled, the Low Oil Temperature Start Inhibit value is 136°F (57.8°C).

If the Enhanced Oil Temperature Protection setting is not enabled, the Low Oil Temperature Start Inhibit value is settable with the Low Oil Temperature Start Inhibit Setpoint using the TechView™.

# Machine Protection and Adaptive

---

## Oil Temperature Control

The oil heater is used to maintain the oil temperature within +/- 2.5°F (1.4°C) of the oil temperature control setpoint. The oil heater is commanded off when the oil pump is commanded on.

If the oil temperature is at or below the Low Oil Temperature Cutout setpoint, this diagnostic will be issued and stops the compressor. This diagnostic is ignored for the first 10 minutes of compressor run. After that, if the oil temperature falls below this cutout temperature for more than 60 consecutive seconds this diagnostic is issued.

## Low Oil Temperature Cutout

If the oil temperature is at or below the Low Oil Temperature Cutout, for more than 60 consecutive seconds this diagnostic will be issued stopping the compressor.

This diagnostic does not take affect during the first 10 minutes of compressor run.

## High Oil Temperature Cutout

This is a latching diagnostic resulting in an immediate shutdown. Default Setpoint value: 165°F (73.9°C)

Implemented to avoid overheating of the oil and the bearings.

If the oil temperature is at or above the High Oil Temperature Cut-out setpoint this diagnostic will be issued, which will stop the compressor. If Oil Temperature violates this temperature cut-out for more than 120 seconds, this diagnostic is issued.

## Manual Oil Pump Control

The oil pump control accepts commands to turn on the oil pump. The manual oil pump choices will be "Auto" or "On." When the oil pump is commanded "On," it will revert to "Auto" in 10 minutes, and is adjustable at DynaView™ or TechView™.

## Controls Chilled Water Reset (CWR)

Chilled water reset is designed for those applications where the design chilled water temperature is not required at partial load. In these cases, the leaving chilled water temperature setpoint can be reset upward using the CWR features.

When the CWR function is based on return water temperature, the CWR feature is standard. When the CWR function is based on outdoor air temperature, the CWR feature is an option requiring an outdoor temperature sensor.

The type of CWR is selected in the Operator Interface settings Menu along with the Reset Ratio, Start Reset Setpoint, and the Maximum Reset Setpoint.

# Machine Protection and Adaptive

---

## High Lift Unloading (500 Ton Family Only)

High Lift Unloading Valve directs discharge gases from the condenser through a solenoid valve directly into the economizer. From the economizer, this gas then flows to the second stage compressor where the economizer normally is connected. The purpose of HLUV is to increase the gas flow rate through the second stage compressor. Bypass gas is allowed to occur using an inline normally closed solenoid valve. The high lift unloading function is dependent on the lift (where lift is defined as the difference between Condenser Saturated Refrigerant Temperature and the Evaporator Saturated Refrigerant Temperature) and on chiller load. When the high lift unloading mode is entered, the High Lift Unloading valve is opened and the inlet guide vane close travel is limited.

The HLUV valve does not modulate the flow rate, but rather is either open or closed. Further, the valve was sized to handle a mass flow sufficient to permit operation below 35% IGV position but not necessarily to 0%. The valve was sized to permit substantial but incomplete unloading and yet was kept as small as practicable to minimize power requirements with HLUV operation.

Not all CVGF chillers require the bypassing of condenser gas. In some tonnages, the High Lift Unloading Valve and copper lines do not exist. The LLID (1A9) with the High Lift Unloading relay always exists.

**Note:** There is noticeable noise, due to gas flow, when the high lift unloading valve is open.

### Functional Description

The following equation determines action of the high lift unloading function:

$$\text{Trigger IGV\%} = 0.98 * \text{Lift} + - 0.065 * \text{CPIM} + C$$

Where Lift is defined as Condenser Saturated Refrigerant Temperature minus Evaporator Saturated Refrigerant Temperature in °F. The CPIM is the average impeller diameter in inches times 100.



# Machine Protection and Adaptive

---

## High Lift Unloading Solenoid

The normally open contact of a CH530 control relay powers the normally closed high lift unloading valve solenoid with the following logic:

LLID Relay State	High Lift Unloading Valve Solenoid	High Lift Unloading Valve	Function
De-energized	De-energized	Closed	No condenser gas bypass
Energized	Energized	Open	Bypass condenser gas

The high lift unloading valve opens if the compressor is running and the IGV position is at or below the Trigger IGV% line – 5%. The high lift unloading valve closes when the IGV position reaches the Trigger IGV% + 5% or the compressor shuts down.

Note that this 5% is of the full IGV travel range of 100%. Also note that operation of the high lift unloading valve is independent of the high lift unloading limit mode as stated below.

### High Lift Unloading Limit Mode

For a Gear Drive chiller, the minimum IGV position is 60% of the Trigger IGV%. When the IGV movement is being limited to the 60% of the Trigger IGV% point, the high lift unloading limit submode is displayed.

### Compressor Start Up

At compressor startup, the chiller is initialized as to not be in high lift unloading. The rules to enter high lift unloading mode are as stated above. Also at startup, sufficient time should be allowed so that an accurate Trigger IGV% may be calculated. Here non-saturated conditions exist right away resulting in unstable temperature measurements.

### Manual Capacity Control

This is the Compressor Control Signal mode override in DynaView™. Here high lift unloading solenoid valve operation, 60% of the Trigger IGV% and displaying of the high lift unloading limit submode is obeyed.

### Chiller Shutdown

The high lift unloading valve is normally closed (de-energized). There is no check performed to ensure the valve is closed without using TechView™.



# Unit Startup

---

## Pre-Commissioning Bump Start Procedure

**Note:** The following procedure is a requirement prior to the first start of the chiller. Failure to complete may result in damage to the compressor and void the warranty.

### Procedure

1. Complete all control settings.
2. Ensure water flows in the condenser and evaporator are correct according to the pre-commissioning procedures.
3. Ensure the unit has been charged with the correct amount of refrigerant and oil and that the oil is the proper operating temperature.
4. Complete a phase rotation test if the voltage is less than 600 volts.

The following checks require TWO personnel to complete. During the bump start of the compressor, one person will look at the rotor from the rear of the motor through the sight glasses to determine correct direction. Looking at the sight glass, the direction will be counter-clockwise. Do not check the rotation of the motor after the start sequence has completed as the indication may be incorrect.

5. With the voltage applied to the mains on the starter, place the chiller in Auto mode.
6. After the pre-lube is complete, let the starter energize the motor, permitting a start.

7. After three seconds, activate the emergency stop by pressing the Immediate Stop button at the CH530 twice in quick succession. During this three second period, the rotor should be seen to rotate in a counter-clockwise direction.
8. If the direction is incorrect, the 3 phases must be isolated from the power source and two legs swapped to obtain the correct direction.

# Unit Startup

---

## Unit Startup

### Unit Start-Up Procedures

#### Daily Unit Start-Up

1. Verify the chilled water pump and condenser water pump starter are in "ON" or "AUTO."
2. Verify the cooling tower is in "ON" or "AUTO."
3. Check the oil tank oil level; the level must be visible in or above the lower sight glass. Also be sure to check the oil tank temperature; normal oil tank temperature before start-up is 140°F to 145°F (60° to 63°C).

**Note:** The oil heater is energized during the compressor off cycle. During unit operation, the oil tank heater is de-energized.

4. Check the chilled water setpoint and readjust it, if necessary, in the Chiller Settings menu.
5. Check the current limit setpoint and readjust it, if necessary, in the chiller settings menu.
6. Press <AUTO>.

Next, the CH530 checks the leaving evaporator water temperature and compares it to the chilled water setpoint. If the difference between these values is less than the start differential setpoint, cooling is not needed.

If the CH530 determines that the difference between the evaporator leaving water temperature and chilled water setpoint exceeds the start differential setpoint, the unit enters the initiate in the start mode, the oil pump and the condenser water pump are started. If condenser water flow is not proven (flow switch 5S2 does not close) within 4 minutes 15 seconds, the unit is locked out on a MMR Diagnostic.

Oil pressure must be verified within 3 minutes or a MMR diagnostic is generated.

When less than 5 seconds remain on the restart inhibit, the pre-start test is conducted on Y-Delta starters. If faults are detected, the unit's compressor will not start, and a MMR Diagnostic will be generated.

**Note:** Whenever the CH530 detects a MMR diagnostic condition during start-up, unit operation is locked out, and manual reset is required before the start-up sequence can begin again. If the fault condition has not cleared, CH530 will not permit restart.

When the cooling requirement is satisfied, the CH530 originates a "Shutting down" signal. The inlet guide vanes are driven closed for 50 seconds, and the unit enters a 1 minute post-lube period. The compressor motor and condenser water pump starter are de-energized immediately, but the oil pump continues to run during this 3 minute interval; the evaporator pump will continue to run. Once the post-lube cycle is done, the unit returns to auto mode.

# Unit Startup

---

## Seasonal Unit Start-Up

**Note:** The following procedure is a requirement prior to the first start of the chiller. Failure to complete may result in damage to the compressor and void the warranty.

1. Close all drain valves, and reinstall the drain plugs in the evaporator and condenser headers.
2. Service the auxiliary equipment according to the start-up and maintenance instructions provided by the respective equipment manufacturers.
3. Vent and fill the cooling tower, if used, as well as the condenser and piping. At this point, all air must be removed from the system (including each pass). Then close the vents in the condenser water boxes.
4. Open all of the valves in the evaporator chilled water circuit.
5. If the evaporator was previously drained, vent and fill the evaporator and chilled water circuit. When all air is removed from the system (including each pass), close the vent valves in the evaporator water boxes.
6. Lubricate the external vane control linkage as needed.
7. Check the adjustment and operation of each safety and operating control.
8. Complete all control settings.
9. Ensure water flows in the condenser and evaporator are correct according to the pre-commissioning procedures.
10. Close all disconnect switches.
11. Ensure the unit has been charged with the correct amount of refrigerant and oil and that the oil is the proper operating temperature.
12. Complete a phase rotation test if the voltage is less than 600 volts.
13. Perform instructions listed in "Unit Start-up" section

## **⚠ WARNING**

### **Live Electrical Components!**

**During installation, testing, servicing and troubleshooting of this product, it may be necessary to work with live electrical components. Have a qualified licensed electrician or other individual who has been properly trained in handling live electrical components performs these tasks. Failure to follow all electrical safety precautions when exposed to live electrical components could result in death or serious injury.**

## **CAUTION**

### **Refrigerant Loss May Occur:**

**To avoid excessive unit refrigerant pressure above the relief valve setting, follow these recommended procedures:**

- **Do not run the pump for more than 30 minutes after chiller shut-down.**  
**Failure to avoid excessive operation of the evaporator water pump with Chiller off may cause loss of refrigerant charge.**
- **If the chilled water loop is used for heating.**
- **Ensure that the evaporator is isolated from the hot water loop before changing over to the heating mode.**

# Unit Shutdown

---

## Unit Shutdown

### Unit Shutdown Procedures

#### Daily Unit Shutdown

**Note:** Refer to Start-Run Shutdown sequence (Figure 9).

1. Press <STOP>.
2. After compressor and water pumps shutdown turn Pump Contactors to OFF or open pump disconnects.

#### Seasonal Unit Shutdown

## CAUTION

### Refrigerant in Oil Pump

#### Damage may occur

The control power disconnect must remain closed to allow oil sump heater operation. Failure to do this will allow refrigerant to condense in the oil pump.

3. Open all disconnect switches except the control power disconnect switch.
4. Drain the condenser piping and cooling tower, if used.
5. To drain the condenser, remove the drain and vent plugs from the condenser headers.
6. Once the unit is secured for winter, the maintenance procedures described under "Annual Maintenance" in the Periodic Maintenance section of this manual should be performed by authorized Trane service technicians.

## ⚠ WARNING

### Refrigerant Discharge Hazard!

**DO NOT ALLOW CHILLER TO INCREASE IN TEMPERATURE OR PRESSURE WHILE THE UNIT IS OFF.**

**Continuous running of pumps while the chiller is off can increase the temperature or pressure and will result in premature release of refrigerant causing bodily harm and possible death to anyone in contact with refrigerant discharge**

# Periodic Maintenance

---

## Periodic Maintenance

### Overview

Use of a periodic maintenance program is important to ensure the best possible unit performance and efficiency.

### Daily Maintenance Checks

Check the chiller's evaporator and condenser pressures, and discharge oil pressure.

**IMPORTANT: IT IS HIGHLY RECOMMENDED THAT THE OPERATING LOG BE COMPLETED ON A DAILY BASIS.**

Check the oil level in the chiller oil sump using the two sight glasses provided in the oil sump head. When the unit is operating, the oil level should be visible in the lower sight glass.

## Weekly Checks

Check the following after the machine has been in operation for at least 30 minutes:

1. Chilled water and condenser water entering and leaving temperatures.
2. Current drawn by the compressor (Amps).
3. Oil level in the oil sump. The oil level must be visible in the sight glass.
4. Condenser pressure, evaporator pressure.
5. Unusual noise, vibration, and so forth

It is strongly recommended that unit readings and observations are recorded on a weekly log sheet.

The acceptance of a warranty claim may depend on this.

## Annual Checks

The yearly maintenance should be performed by an authorized Trane service technician. It should include weekly checks.

1. Check setting and operation of all controls and safety devices.
2. Leak test the entire machine for refrigerant leaks.
3. Check starter contactors for wear and replace if required.
4. Check motor winding insulation.
5. Check motor amps draw.
6. Perform an oil analysis.
7. Perform vibration analysis.
8. Check and adjust the water flow
9. Check and adjust interlocks.
10. Clean condenser tubes.

# Periodic Maintenance

---

## Condenser cleaning

Water available for cooling condensers frequently contains minerals that collect on the condenser tube walls as carbonate scale. Scale accumulation rate will be increased by high condensing temperatures and water with a high mineral content.

Cooling towers, when used, may collect dust and form material that will deposit in the condenser tubes forming sludge.

Scale and sludge formation is indicated by high condensing temperatures and large differences between condensing and leaving water temperatures.

To maintain maximum efficiency, the condenser must remain free of scale and sludge. Even a very thin coating on the tube surface may greatly decrease condenser heat transfer capacity. Two methods for cleaning condenser tubes are mechanical and chemical.

## CAUTION

### Proper Water Treatment!

**The use of untreated or improperly treated water in a CenTraVac may result in scaling, erosion, corrosion, algae and or slime conditions. It is recommended that the services of a qualified water treatment specialist be engaged to determine what water treatment, if any, is required. Trane assumes no responsibility for equipment failures which result from untreated or improperly treated water, or saline or brackish water.**

The mechanical method removes sludge and loose material from the condenser tubes. Working a round nylon or bristle brush attached to a rod, in and out of the tubes loosens the sludge. After cleaning, flush the tubes with clean water.

The chemical method removes scale deposits. The standard condenser water circuit consists of copper, steel and cast iron. Any reliable water treatment company will be able to recommend a cleaning solution for the job.

**Note:** Trane assumes no responsibility if deterioration of the unit is due to inadequate water treatment.

## Evaporator cleaning

The evaporator is part of a closed water circuit and should not accumulate an appreciable amount of scale or sludge. However, if cleaning should be required, use the same methods outlined for cleaning the condenser.

**Note:** Trane assumes no responsibility if deterioration of the unit is due to inadequate water treatment.

# Periodic Maintenance

---

## Controls checkout and adjustments

Controls are checked and calibrated during run-in of the unit prior to shipment. Any adjustments should be made exclusively by authorized Trane service technician.

It is strongly recommended to have proper functioning and setpoints of all controls checked once per year.

### Control settings

For control calibration and check-out, contact an authorized Trane service technician.

### Trouble Analysis

See the Diagnostic List for trouble shooting information. The diagnostic must be analyzed, corrections made by qualified personnel and the latching diagnostic reset before the chiller can be returned to operation.

## Diagnostic Codes

A **Latching** diagnostic will shut down the machine or a part of the machine if so indicated. A latching diagnostic will require a manual reset to restore operation. A **Non-latching** diagnostic will shut down the machine or a part of the machine if so indicated. A non-latching diagnostic will automatically reset when the condition causing the diagnostic goes away. If a diagnostic is informative only, no machine action is taken except to load a diagnostic code into the last diagnostic register. Unless otherwise stated, all active diagnostics will be lost on loss of power.

## Leak Testing Procedure

To leak-test the CVGF, weigh a one-pound charge of trace gas and bring the pressure up to a maximum of 75 psig (517 kPa) using dry nitrogen. This pressure has been found to be adequate to find leaks in a CVGF when using a sensitive electronic leak detector. Set the scale to "medium" which corresponds to a 1/2-ounce (.015l) per year leak rate and probe all joints thoroughly. Be sure and relieve the pressure in the unit before evacuation or leak repair. Local codes take precedence when conducting evacuation.

## WARNING

### **⚠ Hazard of Explosion!**

**Use only dry nitrogen with a pressure regulator for pressurizing unit. Do not use acetylene, oxygen or compressed air or mixtures containing them for pressure testing. Do not use mixtures of a hydrogen containing refrigerant and air above atmospheric pressure for pressure testing as they may become flammable and could result in an explosion. Refrigerant, when used as a trace gas should only be mixed with dry nitrogen for pressurizing units. Failure to follow these recommendations could result in death or serious injury or equipment or property-only damage.**

## Taking an Oil Sample

To obtain an accurate oil sample, the chiller must be operating for a minimum of 30 minutes. An approved oil sample cylinder for R134a should be used. Make sure the upstream oil filter isolation angle valve is completely backseated in order to close the 1/4 inch Schrader valve port. Attach a low loss hose or line with a Schrader valve depressor to the oil sampling 1/4 inch Schrader valve located on the upstream oil filter isolation valve.

Attach the other end of the hose or the line to the oil-sampling cylinder. Evacuate the cylinder and hose or line to remove any non-condensables or moisture. Open the valve on the sample cylinder. Turn the upstream oil isolation angle valve stem approximately one turn clockwise to allow oil under pressure to enter the sample cylinder.

## Periodic Maintenance

---

Weigh the cylinder as the oil is being transferred and shut off the cylinder valve when the desired weight of oil has been transferred. Backseat the angle valve to shut off oil flow and remove the hose from the Schrader valve. Be sure to replace the Schrader and angle valve cap and secure them when sampling is complete. Recover the oil and refrigerant from the oil sample hose or line with an approved R134a recovery unit.

When oil analysis indicates the need to change the oil (high acidity, moisture, and so forth), use the following procedure for removing the oil.

### Removing Compressor Oil

Make sure the unit is not running and the power has been disconnected to the oil heaters. To remove the compressor oil, attach an oil recovery and recharge hose or line to the oil sump drain valve located on the bottom of the oil sump (See Figure 24. Attach the refrigerant vapor return hose or line of the recovery unit to the condenser service valve. Open the oil sump drain valve and condenser service valve and activate the oil recovery process according to the operation specifications of the recovery unit. After all the oil has been recovered and residual R134a refrigerant vapor returned to the condenser, shut the oil drain valve and condenser service valve off and secure the caps to both valves.

**Figure 24. CVGF compressor oil system component locations**

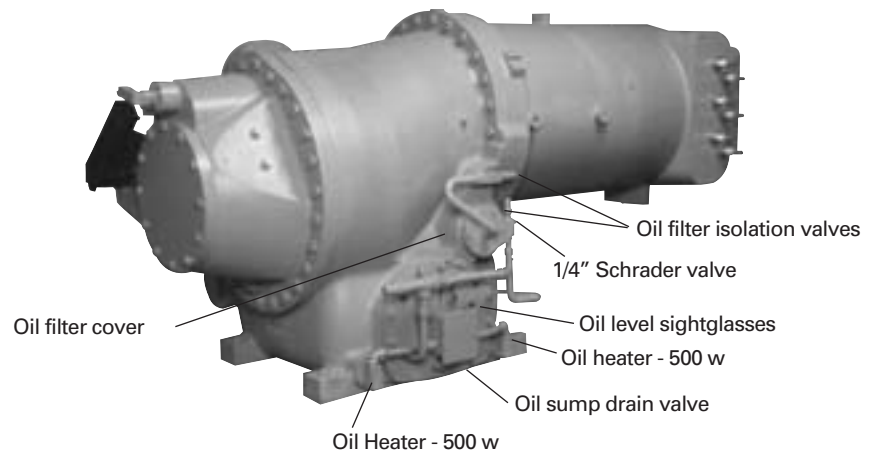



# Periodic Maintenance

---

## CAUTION

### OIL CONTAMINATION

Due to the hygroscopic properties of POE oil, all oil must be stored in metal containers. The oil will absorb water if stored in a plastic container.

### Oil Charging

CVGF units ship factory charged with 15 gallons (56.8 l) of oil and a 5 psig (34 kPa) @ 70 °F (20°C) dry nitrogen holding charge.

**Note:** The correct oil charge for all CVGF units is 15 gallons (56.8 l) of Trane OIL00037 (Trane OIL00037 is R134a miscible oil in 1-gallon (3.785 l) containers). A 5 gallon (18.9 l) container of Trane approved R134a oil is available (Trane OIL00049). As with mineral oil, if water is in the system it will react with the oil to form acids. Use the following table to determine the acceptability of the oil.

POE Oil Properties	Acceptable Levels
Moisture content	less than 300 ppm
Acid Level	less than 0.5 TAN (mg KOH/g)

Trane recommends subscribing to an oil analysis program to determine the condition of the oil rather than changing the oil on a periodic basis. This program will reduce the chiller's lifetime oil consumption and minimize refrigerant emissions. The oil analysis should be performed by a qualified laboratory, experienced in refrigerant and oil chemistry, and the servicing of Trane centrifugal chillers.

### Oil Charging Procedure

Use appropriate oil as specified:

USA	Europe
Oil 0037	Oil 021E
Oil 0049	Oil 0020E

### Unit Charged With Refrigerant

1. Decant the oil from the shipping container into the cylinder of an oil recovery and recharge unit per the unit operation instructions (15 gallons (56.8 l) required).
2. A vacuum of at least 500 microns must be attained and an oil temperature of at least 122°F (50°C) maintained to remove existing moisture. A standing vacuum rise test should be performed after the distillation process is complete to insure the oil has completely outgassed any moisture or non-condensibles. A vacuum rise of less than 100 microns (0.1 mm Hg) in a 2 hour period indicates the oil is ready for transfer.

## Periodic Maintenance

---

3. Attach the oil transfer hose of the recovery unit oil pump to the oil sump charging and drain valve and evacuate.
4. Open the oil charging valve on the bottom of the oil tank of the CVGF and operate the oil recovery and recharge unit oil pump to charge the oil into the tank.
5. When the oil is at the center of the upper sight glass, stop the transfer of oil.
6. Energize the oil heaters.
7. At the control panel, go to the Service Tests menu and scroll down to the "oil pump" screen. Turn the oil pump on in manual mode and let it run for several minutes. This will charge the oil lines and oil cooler with oil.
8. After shutting the oil pump off, check the oil level in the sump sight glasses. The level should be between the center of the upper glass and center of the lower sight glass. Float balls are installed in each sight glass to allow easy level determination.
9. If the oil level is below the center of the lower sight glass, charge oil into the sump as outlined in step 4.

10. Close the oil sump drain valve and remove the oil charging line.
11. Reinstall the oil drain valve cap and tighten securely.

### Unit in a Vacuum.

1. Connect one end of an oil charging line to an oil supply (15 gallons (56.8 l) total required) and the other end to the oil sump drain valve located at the bottom of the oil sump (See Figure 23). If possible, evacuate the oil charging line to remove any non-condensables and moisture. This will require a shutoff valve on the oil supply side of the line and an access valve located on the line itself.
2. Open the oil sump drain valve and allow the vacuum to draw the oil into the sump until the upper sight glass ball is located in the center of the upper sight glass.
3. Close the oil sump drain valve and remove the oil charging line. Reinstall the oil drain valve cap and tighten securely.
4. Make sure the oil heaters are energized and the oil is up to temperature (greater than 122°F (50°C)).
5. Continue pulling a vacuum on the unit to remove any residual moisture or non-condensables, which may have been introduced during the oil charging. A vacuum of at least 500 microns (0.5 mm Hg) should be attained before blanking off the vacuum pump. A vacuum rise test should be performed to insure all non-condensables and moisture have been removed from the system before charging the unit with refrigerant 134a. The vacuum level should not rise by more than 100 microns (0.1 mm Hg) in a 2 hour period.
6. After charging the unit with refrigerant, operate the oil pump in the manual mode as outlined in step 7 in the preceding procedure and follow that procedure if additional oil is required to bring the level between the center of the two sight glasses.

# Periodic Maintenance

---

## Replacing the Oil Filter

The oil filter should not be changed unless absolutely required due to plugging, which will shut the chiller off on low oil pressure or if the oil is required to be changed. To replace the oil filter, use the following procedure:

1. Be sure the chiller is in the Stop mode.
2. Locate the two oil filter isolation valves (See Figure 24).
3. Connect an approved refrigerant recovery unit for R134a to the 1/4 inch Schrader valve on the oil filter inlet isolation valve to allow removal of oil and refrigerant from the oil filter cavity.
4. Close both isolation valves.
5. Recover the refrigerant and oil out of the oil filter cavity.
6. Remove the oil filter cover by removing the bolts and loosening the Roto-Lock connector on the outlet oil filter isolation valve.

**Note:** When removed, do not allow any contaminants to get on the oil filter cover. Reinstalling a contaminated oil filter cover could decrease the life of the compressor.

7. Remove the oil filter and o-ring.
8. Install a new oil filter, o-ring, and Roto-Lock nylon seal.
9. Replace the oil filter cover and torque the bolts and Roto-Lock connector. The cover is torqued to 19 lb-ft (2.62 N-m) and the Roto-Lock to 90 lb-ft (12.44 N-m).
10. Evacuate the oil filter cavity by attaching a deep vacuum pump to the 1/4 inch Schrader valve and pulling at least a 500 micron (0.5 mm Hg) vacuum. Do a standing vacuum rise test to determine if any leaks are present. If leak free, remove the vacuum pump from the valve.
11. Replace the Schrader valve cap and tighten.
12. Open both isolation valves.
13. On the DynaView™ display, select Settings, Mode overrides and select Oil Pump. Start and run the oil pump in manual mode to charge the oil filter with oil. Allow the pump to run for several minutes and shut the oil pump off by going back to the Auto mode at the control panel.
14. Check the oil level in the sump and if it is below the center of the lower sight glass, add oil by following the oil charging procedure outlined previously.

# Periodic Maintenance

---

## Oil Sump Heaters

The CVGF uses two 500 watt heaters to maintain the oil sump temperature at 136°F (57.7°C). These heaters are located in the lower oil sump casting, one on each side of the oil sump cover, and can be serviced without removing the refrigerant or oil, since the heaters are not located in the oil sump itself but in the casting (See Figure 24).

The CH530 will not allow the chiller to start unless the oil sump temperature is at least 30°F (16°C) above saturated evaporator temperature, or at least 105°F (58°C), whichever is higher. The oil sump comes factory insulated and must remain insulated to allow the oil temperature to maintain 136°F (57.7°C) while the unit is off.

The oil heaters are only energized during the unit "off" cycle to maintain oil temperature for startup. During the run cycle, the oil sump heaters are de-energized and the oil temperature may vary depending on load and operating conditions. The unit will trip on a latching diagnostic of high oil temperature if the oil exceeds 165°F (74°C).

## Oil Pressure Protection

A differential oil pressure switch provides protection for the CVGF should the oil pressure fall below safe operating levels for any reason. This switch opens at 9 psid (62kPa) and closes at 12 psid (82 kPa). The oil pressure regulator is factory set to maintain oil pressure between 18 to 22 psid (124-151 kPa). The unit will not start if the oil pressure is below 12 psid (82 kPa).

## Adjusting the Oil Pressure Regulating Valve

The oil pressure regulator should be calibrated to maintain 18 to 22 psid during commissioning. In the event that the oil pressure switch will not close to allow unit startup, the following diagnostic procedure should be followed:

1. With the unit and the oil pump off, connect a pressure gauge to the service valve after the oil filter and another gauge to the Schrader valve located next to the oil pressure switch capillary on the oil sump. (An optional method is to use a differential pressure gauge instead of two separate gauges.)

2. On the DynaView™ display, select Settings, Mode overrides and select Oil Pump. Place oil pump in manual mode. Check the oil pressure gauge readings and calculate the differential oil pressure by subtracting the oil sump pressure reading from the discharge oil pressure reading.

If the differential pressure is between 18 to 22 psid (124-151 kPa), the oil pressure regulating valve should not be adjusted. If the oil pressure switch is not closed at pressures above 12 psid (82kPa), the switch is defective and should be replaced. If the switch is closed the unit will not start due to a low oil pressure diagnostic. If the differential oil pressure cannot be achieved, the oil pump may be running backwards.

## Periodic Maintenance

---

3. To reverse the oil pump motor rotation, two leads must be swapped on the oil pump motor contactor. Be sure to remove all power from the unit before doing any electrical wiring changes.

**Note:** Be sure to perform the Bump Start test to determine proper compressor rotation before operating the chiller.

If the differential oil pressure measured is below 12 psid (82 kPa), the oil filter may be plugging or the regulator may need adjustment.

4. Then check the pressure drop across the oil filter, connect a gauge to the service valve before the oil filter and another gauge to the service valve after the oil filter. Subtract the pressure reading taken from after the oil filter from the gauge before the oil filter to obtain the pressure drop. If the pressure drop is excessive (more than 8 psid (54 kPa)), shut the oil pump off and replace the oil filter per the procedure outlined previously.

5. When the oil filter change is completed, check the differential oil pressure and if it is below 18 psid (124 kPa), adjust the oil pressure regulator to obtain a reading of between 18 to 22 psid (124-151 kPa).

If the pressure drop across the filter is not excessive, but the oil differential pressure is below 18 psid, adjust the oil pressure regulating valve to obtain 18 to 22 psid (124-151 kPa) oil pressure. To increase pressure, remove the oil pressure regulator cap and screw the regulator stem in a clockwise direction. Be sure to replace the cap and tighten when adjustment is complete.

6. Remove the pressure gauges when all diagnostic work is complete. Be sure and replace and secure any valve caps which were removed.

### CVGF Oil Pump

The oil pump for the CVGF is a positive displacement, direct drive pump, three phase motor. The motor must be phased correctly to provide positive differential oil pressure. This pump and motor is located within the oil sump and can not be serviced without recovering the refrigerant and removing the oil from the machine.

# Periodic Maintenance

---

## Refrigerant Charge

If a low refrigerant charge is suspected, first determine the cause of lost refrigerant. Once the problem is repaired follow the procedures below for evacuating and charging the unit.

## WARNING

### Hazardous Voltage!

**Disconnect all electric power, including remote disconnects before servicing. Follow proper lockout/tagout procedures to ensure the power can not be inadvertently energized. Failure to disconnect power before servicing could result in death or serious injury.**

### Evacuation and Dehydration

1. Disconnect ALL power while evacuating the system.
2. Connect the vacuum pump to the 5/8" flare connection on the bottom of the evaporator.

3. Remove all of the moisture from the system to insure a leak free unit. Pull the system down below 500 microns (0.5 mm Hg).
4. After the unit is evacuated, perform a standing rise test for at least an hour. This vacuum should not rise more than 100 microns (0.1 mm Hg) per hour to a maximum of 500 microns (0.5 mm Hg) over 12 hours. If the vacuum rises above this, either there is a leak or the unit has moisture present.

**Note:** If oil is in the system, this test is more difficult. The oil is aromatic and will give off vapors that will raise the pressure of the system. Check for oil temperature >122°F (50°C).

## Refrigerant Charging

Once the system is leak and moisture free, use the 5/8" flare connections at the bottom of the evaporator and side of condenser to add refrigerant charge. See Unit Nameplate for correct refrigerant charge amounts.

Add the refrigerant charge as a vapor until the system pressure is above 29.4 psi (203 kPa) or Temperature is above 34°F (1°C). Liquid refrigerant may be added once these conditions are achieved.

## CAUTION

### Possible Freeze-up

**Water can freeze during charging. Circulate water during charging to prevent freezing.**

## Caution

### Charge vapor in the unit until:

- System pressure is above 29.4 psig (203 kPa )
- The saturation temperature of R134a is above 34°F (1°C)





**Trane**  
**A business of American Standard Companies**  
**[www.trane.com](http://www.trane.com)**

For more information contact your local Trane office  
or e-mail us at [comfort@trane.com](mailto:comfort@trane.com)

---

Literature Order Number	CVGF-SVU02B-E4
File Number	SL-RF-CTV-CVGF-SVU02B-E4-0205
Supersedes	CVGF-SVU02A-E4-1202
Stocking Location	China

---

*Trane has a policy of continuous product and product data improvement and reserves the right to change design and specifications without notice. Only qualified technicians should perform the installation and servicing of equipment referred to in this publication.*

*Société Trane – Société Anonyme au capital de 41500 000 F – Siège Social: 1 rue des Amériques – 88190 Golbey – France – Siret 306 050 188-00011 – RSC Epinal B 306 050 188  
Numéro d'identification taxe intracommunautaire: FR 83 3060501888*