



IPC Eagle

OPERATIONS MANUAL & PARTS LIST

AM3
Air Mover



BEFORE OPERATING THE MACHINE

Read the manual carefully and completely before attempting to operate the unit. This manual has important information for the use and safe operation of the machine. Keep this manual handy at all times. This machine will assure years of satisfactory service if operated and maintained according to recommendations in this manual.

Electrical- 120 Volt

This machine is designed to operate on a standard 15 amp., 120 volt, 60 Hz, AC circuit. Voltages below 105 volts AC or above 125 volts AC could cause serious damage to the motor

Electrical- 230 Volt

This machine is designed to operate on a standard 10 amp., 230 volt, 50 Hz, AC circuit.

IMPORTANT SAFETY INSTRUCTIONS READ AND SAVE THESE INSTRUCTIONS BEFORE USING

DANGER

- Improper connection of the equipment- grounding conductor can result in a risk of fire, electric shock or injury to person.

Check with a qualified electrician or service person if you are in doubt as to whether the outlet is properly grounded. Do not modify the plug provided with the air mover- if it will not fit the outlet, have a proper outlet installed by a qualified electrician.

WARNING

- This equipment is not designed to handle or use combustible/ volatile substances such as gasoline or kerosene, in, on, or near the machine. The use of such materials will cause an extreme hazardous condition.
- Do not immerse or use this machine in standing water. Such use may cause electric shock.
- Disconnect the power cord from the outlet before servicing.
- Ensure children do not have access to the equipment. Do not allow children to play with or near the unit or in its air flow.
- Do not use with damaged cord or plug. If air mover is not working as it should, has been dropped, damaged, left outdoors, or dropped into water, return it to an qualified service center.
- Do not operate any fan with a damaged cord or plug. Discard fan or return to an qualified service facility for examination and/or repair.
- Do not run cord under carpeting. Do not cover cord with throw rugs, runners or similar coverings. Do not route cord under furniture or appliances. Arrange cord away from traffic area and where it will not be tripped over.
- Repairs only allowed by a qualified service center. Do not attempt to disassemble or repair the unit if you are not qualified to do so.
- When using an extension cord, use only a 3 conductor grounding cord- 12 ga. wire or heavier.
- Never operate with the safety grills removed. Personal injury may result.
- To avoid electric shock, do not expose the unit to rain- store it indoors only.
- Do not expose machine to freezing temperatures.
- Do not move or carry the unit when it is turned on.
- Do not pull or carry by the cord, use cord as a handle, close a door on the cord, or pull cord around sharp edges or corners.
- Keep cord away from heated surfaces.
- Do not unplug by pulling on cord. To unplug, grasp the plug, not the cord.
- Do not handle plug or air mover with wet hands.
- Do not put object into openings. Do not use with any opening blocked; keep free of dust, lint, hair and anything that may reduce air flow.
- Keep hair, loose clothing, fingers and all parts of the body away from openings and moving parts.
- Turn off all controls before unplugging.
- Connect to a properly grounded outlet only. *See grounding instructions.*
- Operate unit on level and stable surface to prevent it from falling and possibly causing injury.
- Do not drop or throw the unit. Treatment of this type can cause damage to the components and create a hazardous condition.
- To reduce the risk of fire or electric shock, do not use this air mover with any solid-state speed control devices.

FAILURE TO COMPLY WITH THE ABOVE WARNING INSTRUCTION WILL VOID THE WARRANTY.

GROUNDING INSTRUCTIONS:

The 120 V. A/C and the 230 V. A/C models have been outfitted with the appropriate grounded connectors. Make sure the machine is connected to a grounded outlet having the same configuration as the grounded plug. No adaptor should be used with this machine. Any modification to the connectors will void the warranty.

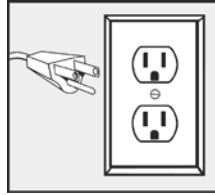
**OPERATING PROCEDURES:**

Plug the Air Mover into a standard grounded outlet with correct voltage and amperage. Turn on the switch and check that the unit operates properly before leaving it unattended. *Do not carry or move the Air Mover when it is running.*

MAINTENANCE:

1. Disconnect the power cord from the outlet before performing this maintenance procedure.
2. Inspect the electrical cord and wiring for damage or discoloration.
3. Inspect for loose fasteners.
4. Clean screens on the side and front of the unit.
5. Listen for abnormal sounds.
6. Keep unit clean.
7. Motor does not require lubrication.

PERIODIC MAINTENANCE:

Use compressed air or a vacuum to remove lint, etc, from the motor, screen or blower. Do not wet the motor or the wiring. Do not use a pressure washer to clean the unit.

TROUBLESHOOTING

ELECTRICAL SYSTEM

PROBLEM	POSSIBLE CAUSE
Does not turn on	<ol style="list-style-type: none">1. Switch is defective.2. Wall circuit breaker is tripped.3. Defective power cord.4. Capacitor is defective.
Does not operate at all speeds	<ol style="list-style-type: none">1. Switch is defective.2. Capacitor is defective.
Blower wheel rubs	<ol style="list-style-type: none">1. Wheel is out of round.
Unit makes abnormal sounds	<ol style="list-style-type: none">1. Defective motor.2. Foreign object stuck.

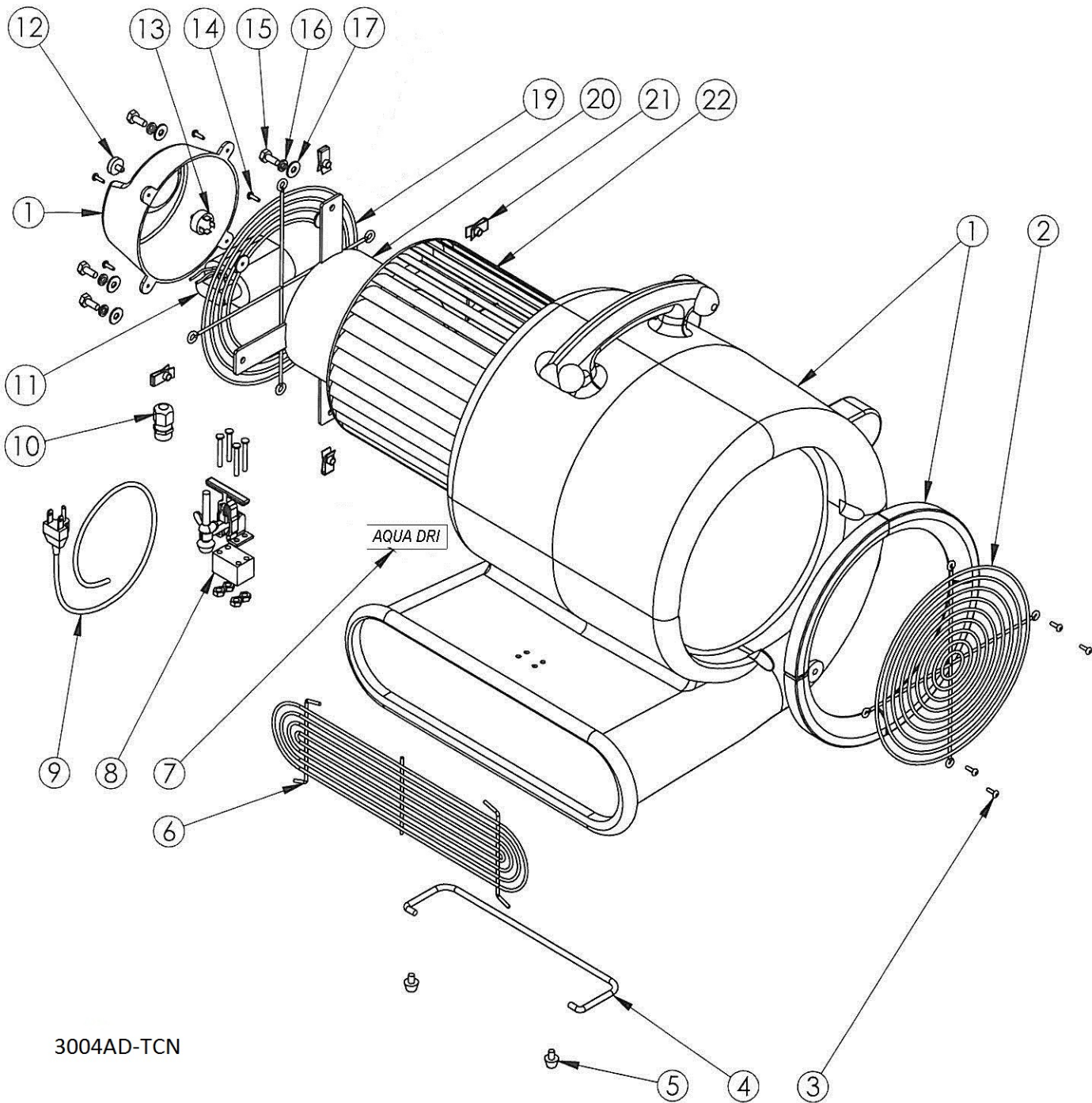

3004AD-TCN

AIR MOVER PARTS LIST

ITEM #	3004AD-TCN	DESCRIPTION	QTY
1	F13504-BLUE	ROTOMOLD PLASTIC HOUSING	1
2	D11774	INTAKE GRILLE	1
3	C11893	8 X .5 PAN PHILLIPS BLACK	4
4	D11778	KICKSTAND	1
5	E11841	GROMMET	2
6	D11773	FRONT GRILLE	1
7	H11908	TRUSTED CLEAN LABEL	1
9	B10719	POWER CORD	1
10	B11821	STRAIN RELIEF	1
11	B13511	CAPACITOR ATTACHED TO MOTOR	1
12	G00515-3	KNOB, SPEED CONTROL SWITCH	1
13	B11825	ROTARY SWITCH	1
14	C13026	8 X 32 X .63 PAN PHILLIPS BLACK	4
15	C00314-1	HEX BOLT, 1-4 X 20 X .63 IN	4
16	C00254	LOCK WASHER, 1-4 IN SPLIT	4
17	C00233	WASHER, FLAT, .25 IN	4
19	D11775	MOTOR GRILLE	1
20	G11823	MOTOR	1
21	C00267-1	U-NUT, 1-4-20	1
22	G11826	FAN WHEEL	1