

**TM 9-4910-586-14&P**

---

**TECHNICAL MANUAL**

OPERATOR, ORGANIZATIONAL, DIRECT SUPPORT  
AND GENERAL SUPPORT MAINTENANCE MANUAL  
(INCLUDING REPAIR PARTS LIST)

FOR

**STAND, TRANSPORT, ENGINE**

(NSN 4910-00-338-6673)

---

HEADQUARTERS, DEPARTMENT OF THE ARMY

DECEMBER 1979



TECHNICAL MANUAL  
No. 9-4910-586-14&P

HEADQUARTERS  
DEPARTMENT OF THE ARMY  
WASHINGTON, DC, 31 December 1979

**OPERATOR, ORGANIZATIONAL, DIRECT SUPPORT AND GENERAL SUPPORT  
MAINTENANCE MANUAL  
(INCLUDING REPAIR PARTS LIST)  
FOR  
STAND, TRANSPORT, ENGINE  
(NSN 4910-00-338-6673)**

**REPORTING ERRORS AND RECOMMENDING IMPROVEMENTS**

**You can help improve this manual. If you find any mistakes or if you know of a way to improve the procedures, please let us know. Mail your letter, DA Form 2028 (Recommended Changes to Publications and Blank Forms), or DA Form 2028-2, located in the back of this manual direct to: Commander, US Army Armament Materiel Readiness Command, ATTN: DRSAR-MAS, Rock Island, IL 61299. A reply will be furnished directly to you.**

**NOTE**

This manual is published for the purpose of identifying an authorized commercial manual for the use of the personnel to whom this stand is issued.

Manufactured by: KHC Industries, Inc.  
41 Deming Road  
Berlin, CT 06037

Procured under Contract No. DAAA09-76-C-6675

This technical manual is an authentication of the manufacturer's commercial literature and does not conform with the format and content specified in AR 310-3, Military Publications. This technical manual does, however, contain available information that is essential to the operation and maintenance of the equipment.

## TABLE OF CONTENTS

Section		Page
I	INTRODUCTION AND DESCRIPTION . . . . .	1
	1-1. General . . . . .	1
	1-3. Purpose . . . . .	1
	1-5. Description . . . . .	1
	1-7. Stand Base Assembly . . . . .	1
	1-9. Support Assemblies . . . . .	1
II	OPERATION . . . . .	2
	2-1. General . . . . .	2
	2-3. Preparation For Use . . . . .	2
	2-5. Operation Procedures . . . . .	2
III	MAINTENANCE INSTRUCTIONS . . . . .	3
	3-1. General . . . . .	3
	3-3. Cleaning and Lubrication. . . . .	3
	3-5. Inspection . . . . .	3
	3-7. Repair . . . . .	3
	3-9. Rust Removal and Repainting . . . . .	3
	3-10. Disassembly. . . . .	4
	3-12. Removal of Support Assemblies. . . . .	4
	3-13. Removal of Wheel Assemblies. . . . .	4
	3-14. Removal of Jack Stand. . . . .	4
	3-15. Removal of Rear Brace (Left and Right Legs) . . . . .	4
	3-16. Assembly. . . . .	4
IV	PARTS LIST. . . . .	5
	4-1. General . . . . .	5
	4-3. Parts List. . . . .	5

## SECTION I INTRODUCTION AND DESCRIPTION

### 1-1. GENERAL

1-2. This manual provides operation, maintenance, and parts listing information for the Department of the Army, Drawing Number 8708857 Universal Transport Stand.

### 1-3. PURPOSE

1-4. The Universal Transport Stand, herein referred as Stand, is provided for moving of engines and heavy equipment. Adjustable supports provide a rigid mounting for various size equipment . In addition to providing a means of moving equipment, the Stand may be utilized to provide storage of equipment to enable quick access when required.

### 1-5. DESCRIPTION

1-6. The Stand is a general purpose, heavy-duty, engine transport stand of welded steel construction. The Stand is composed of a base assembly mounted on wheels and four vertically-mounted support assemblies.

### 1-7. Stand Base Assembly

1-8. The Stand base assembly is composed of a welded, steel channel frame with attached wheel assemblies, jack stand, and rear brace assembly. The front of the Stand utilizes swivel wheel assemblies, while the rear of the Stand utilizes fixed wheel assemblies. An adjustable jack stand is provided at the left front of the Stand base assembly to lock the Stand in position, and to avoid rolling on inclines. The rear brace assembly, provided as an additional means of support for engine mounting, is bolted through slotted holes in the rear cross-member of the Stand base assembly to enable lateral adjustment.

### 1-9. Support Assemblies

1-10. The support assemblies, which are vertically mounted and adjustable, are the main load-bearing supports of the Stand. The support assemblies are bolted to the Stand base assembly through slotted holes in the support assemblies and the Stand base assembly. Slots axes are 90 degrees apart, enabling a wide range of lateral and longitudinal adjustment to suit various equipment dimensions. Lateral adjustment provides for dimensions of 9 to 39 inches (nominal) width. Longitudinal adjustment provides for dimensions of 7-3/8 to 31-5/8 inches (nominal) between support assembly centerlines.

## SECTION II OPERATION

### 2-1. GENERAL

2-2. The Stands are shipped banded together on an approximate 42 x 48 inch pallet. The rear brace assembly (right and left legs), the support assemblies, and hardware for each Stand is packaged in a cardboard box positioned and banded in the center of the pallet. One box is supplied with each stand. Preparation for use and operation procedure follow.

### 2-3. PREPARATION FOR USE

2-4. The following procedures provide unpacking and set-up instructions for the Stand. (See figure 1.)

1. Remove the steel bands securing the Stand(s) to the pallet.
2. Remove the Stand(s) from the pallet.
3. Remove the steel bands attaching the cardboard box(es) to the pallet.
4. Remove the cardboard box(es) from the center of the pallet.
5. Remove the support assemblies, rear brace assembly (right and left legs), and hardware from each cardboard box.
6. Attach four support assemblies (item 10) to the Stand base assembly with screw (item 11), nut (item 14) and washers (items 12 & 13).
7. Loosely attach rear brace assembly left leg (item 19) to left end of the rear cross-member with screw (item 7), washers (items 17 & 18), and nut (item 9).
8. Loosely attach rear brace assembly right leg (item 19) to right end of rear cross-member with screw (item 21), spacer (item 22), washers (items 17 & 18), and nut (item 9).

### NOTE

Spacer (item 22) is inserted between right leg and rear crossmember.

9. Securely attach right and left legs together with screw (item 7), washer (item 17), and nut (item 9).
10. Secure mounting bolts on lower end of left and right legs at rear crossmember.

### 2-5. OPERATION PROCEDURES

2-6. Operation procedures for use of the Stand are as follows:

1. Position the Stand as required near the equipment to be moved.
2. Tighten the jack stand at the left front of the Stand to insure that the Stand is steady.
3. Adjust the vertical support assemblies and rear brace assembly as required to accommodate the dimensions of the load.

4. Using a suitable lifting device, lift the equipment to be moved into position over the Stand and lower the equipment into position.
5. Insure that the equipment is secure in the Stand prior to proceeding.
6. Loosen the jack stand at the left front of the Stand.
7. Move the equipment mounted on the Stand to the desired location.
8. Tighten the jack stand at the left front of the Stand.
9. Using a suitable lifting device, lift the equipment from the Stand.

### SECTION III MAINTENANCE INSTRUCTIONS

#### 3-1. GENERAL

3-2. Maintenance is limited to general cleaning, lubrication, and replacement of damaged parts.

#### 3-3. CLEANING AND LUBRICATION

3-4. Periodically, the Stand should be wiped clean of grease and dirt. The wheel assemblies should be greased with general-purpose grease (MIL-G-23549 or equivalent). Note that each wheel assembly has a grease fitting on the wheel axle and, in addition, each swivel wheel assembly has a grease fitting on the swivel axis.

#### 3-5. INSPECTION

3-6. The Stand should be inspected periodically for damaged parts, faulty or loosely-mounted wheel assemblies, and rust build-up. Inspect wheel assemblies for binding, chipped wheels and defective bearings. Refer to paragraph 3-7 for repair procedures.

#### 3-7. REPAIR

3-8. Repair procedures are limited to rust removal and repainting and replacement of damaged parts. Faulty wheel assemblies and damaged parts should be replaced (refer to paragraph 3-10 for disassembly procedures).

#### 3-9. Rust Removal and Repainting

1. Remove the affected part (refer to paragraph 3-10 for disassembly procedures).
2. Remove all rust from the area with sandpaper.
3. Apply military approved primer to the area.
4. Allow primer to dry thoroughly.
5. Apply military approved matching paint.
6. Allow the paint to dry thoroughly.

7. Reattach the part to the Stand (refer to paragraph 3-17 for assembly procedures).

### 3-10. DISASSEMBLY

3-11. The following procedures detail disassembly of the Stand. Retain all attaching hardware for reassembly. Refer to figure 1 for parts location.

#### 3-12. Removal of Support Assemblies

1. Remove attaching screw, nut, and washers from base of the support assembly (item 10).
2. Lift support assembly from Stand base assembly.

#### 3-13. Removal of Wheel Assemblies

1. Remove four attaching screws, nuts, and washers from each Stand base assembly mounting plate (item 16).
2. Remove each wheel assembly (items 6 & 15) and wheel assembly mounting plate (item 3A).

#### 3-14. Removal of Jack Stand

1. Loosen setscrew (item 5) and remove foot (item 4).
2. Using suitable wrench, unthread locking screw (item 2) by turning counterclockwise.
3. Remove locking screw.

#### 3-15. Removal of Rear Brace (Left and Right Legs)

1. Remove attaching screw, washer, and nut securing left and right legs (item 19).
2. Remove attaching screw, washer, and nut securing left leg and remove left leg.
3. Remove attaching screw, washer, spacer, and nut securing right leg and remove right leg.

### 3-16. ASSEMBLY

3-17. For assembly, reverse the disassembly procedures of paragraph 3-10 and tighten attaching screws securely.



SECTION IV  
PARTS LIST

4-1. GENERAL

4-2. This section provides a listing of part numbers and a description for all parts and assemblies of the Stand.

4-3. PARTS LIST

4-4. All parts are referenced to figure 1. Unless otherwise noted, part numbers listed have been assigned by the Rock Island Arsenal. The code number of the Rock Island Arsenal is listed in the description column, in addition to drawing number.

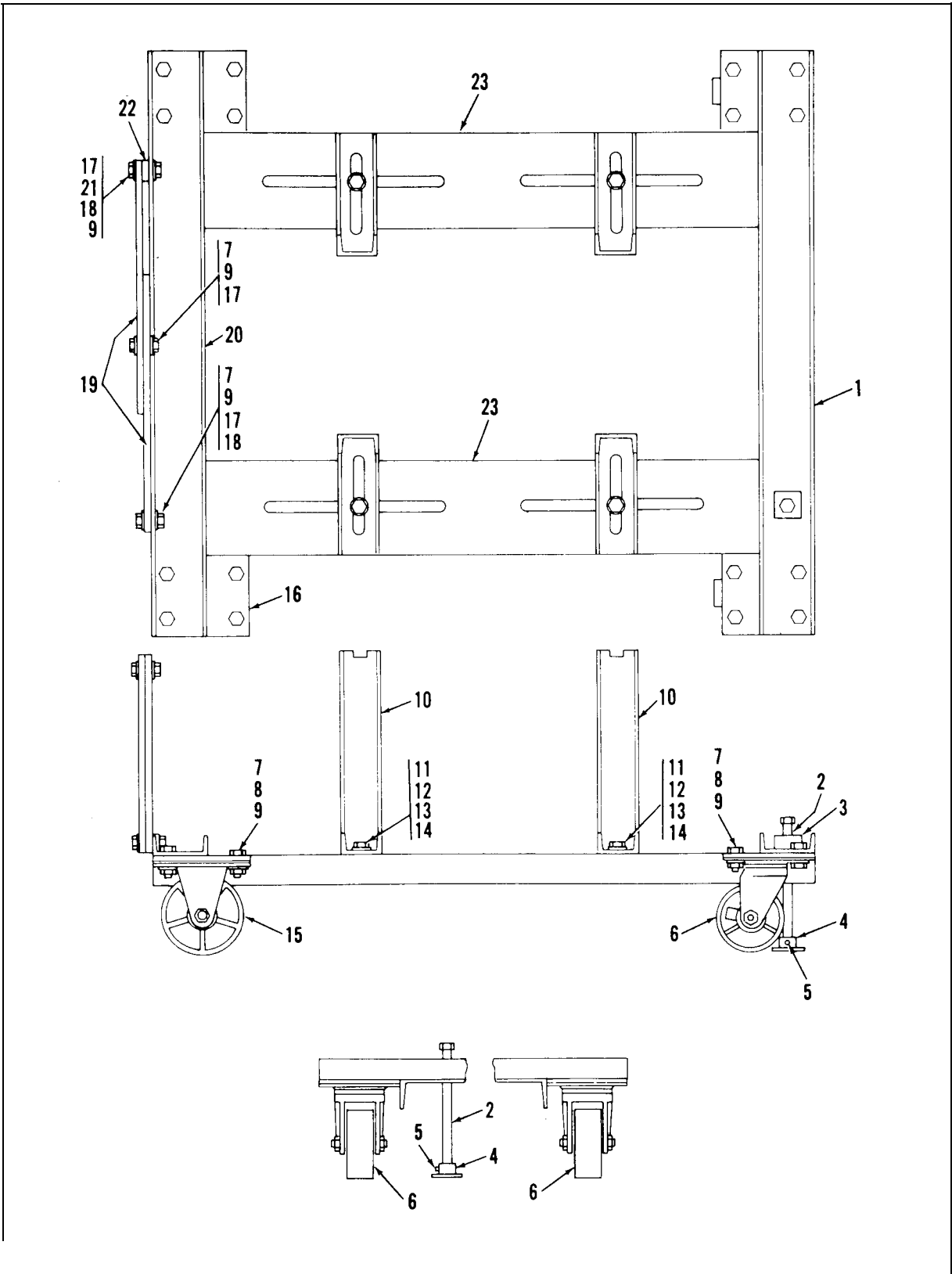

Figure 1. Universal Transport Stand

INDEX	PART	DESCRIPTION	QTY.
NO.	NUMBER		
1	8708860	CROSSMEMBER, FRONT; MFR. 19204 DWG. C8708860	1
2	7550159	SCREW, LOCKING; MFR. 19204, DWG. B7750159	1
3	8708871	PLATE; MFR. 19204, DWG. A8708871	1
4	8708870	FOOT; MFR. 19204, DWG. A8708870	1
5	MS51964-65	SETSCREW	1
6	7-5609-169	WHEEL ASSEMBLY, FRONT SWIVEL; MFR. 07393	2
7	MS90726-115	SCREW	18
8	MS35338-48	WASHER	16
9	MS51968-14	NUT	19
10	8708862	SUPPORT ASSEMBLY; MFR. 19204, DWG. C8708862	4
11	MS90726-162	SCREW	4
12	MS27183-21	WASHER	4
13	MS35338-50	WASHER	4
14	MS51968-20	NUT	4
15	7-5608-169	WHEEL ASSEMBLY, REAR; MFG. 07393	2
16	7550160	PLATE; MFR. 19204, DWG. B7550160	4
17	MS27183-18	WASHER	4
18	NAS 1099-8	WASHER, BEVEL	2
19	8708865	LEG; MFR. 19204, DWG. B8708865	2
20	8708861	CROSSMEMBER, REAR; MFR. 19204, DWG. C8708861	1
21	MS90726-116	SCREW	1
22	8708858	SPACER; MFR. 19204, DWG. A8708858	1
23	8708866	CHANNEL, SIDE; MFR. 19204, DWG. C8708866	2



INSTRUCTIONS FOR REQUISITIONING PARTS

NOT IDENTIFIED BY NSN

When requisitioning parts not identified by National Stock Number, it is mandatory that the following information be furnished the supply officer.

- 1 - Manufacturer's Federal Supply Code Number - 3N091
- 2 - Manufacturer's Part Number exactly as listed herein.
- 3 - Nomenclature exactly as listed herein, including dimensions, if necessary.
- 4 - Manufacturer's Model Number - Model
- 5 - Manufacturer's Serial Number (End Item)
- 6 - Any other information such as Type, Frame Number, and Electrical Characteristics, if applicable.
- 7 - If DD Form 1348 is used, fill in all blocks except 4, 5, 6, and Remarks field in accordance with AR 725-50.

Complete Form as Follows:

(a) In blocks 4, 5, 6, list manufacturer's Federal Supply Code Number-3N091 followed by a colon and manufacturer's Part Number for the repair part.

(b) Complete Remarks field as follows:  
Noun: (nomenclature of repair part)  
For: NSN: 4910-00-338-6673  
Manufacturer: KHC Industries, Inc.

Model:  
Serial: (of end item)

Any other pertinent information such as Frame Number, Type, Dimensions, etc.

By Order of the Secretary of the Army:

Official:

J. C. PENNINGTON  
*Major General, United States Army*  
*The Adjutant General*

E. C. MEYER  
*General, United States Army*  
*Chief of Staff*

RECOMMENDED CHANGES TO EQUIPMENT TECHNICAL PUBLICATIONS



THEN... JOT DOWN THE DOPE ABOUT IT ON THIS FORM, CAREFULLY TEAR IT OUT, FOLD IT AND DROP IT IN THE MAIL!

SOMETHING WRONG WITH THIS PUBLICATION?

FROM: (PRINT YOUR UNIT'S COMPLETE ADDRESS)

Your mailing address

DATE SENT

Date you filled out this form

PUBLICATION NUMBER

TM 9-4910-586-14&P

PUBLICATION DATE

31 Dec 79

PUBLICATION TITLE

Maintenance Manual for Stand, Transport, Engine

BE EXACT... PIN-POINT WHERE IT IS

PAGE NO.	PARA-GRAPH	FIGURE NO.	TABLE NO.
2	4.6		

IN THIS SPACE TELL WHAT IS WRONG AND WHAT SHOULD BE DONE ABOUT IT:

In table of contents, the page reference for maintenance procedures is 5, not 2.

Step 3 should read: Hand tighten the jack stand at the right front of the stand.

SAMPLE

PRINTED NAME, GRADE OR TITLE, AND TELEPHONE NUMBER

John Doe, SP/4, 000-0000

SIGN HERE:

*John Doe*

TEAR ALONG PERFORATED LINE

FILL IN YOUR  
UNIT'S ADDRESS

FOLD BACK

DEPARTMENT OF THE ARMY

POSTAGE AND FEES PAID  
DEPARTMENT OF THE ARMY  
DOD 314



OFFICIAL BUSINESS  
PENALTY FOR PRIVATE USE \$300

Commander  
US Army Armament Materiel Readiness Command  
ATTN: DRSAR-MAS  
Rock Island, IL 61299

TEAR ALONG PERFORATED LINE



RECOMMENDED CHANGES TO EQUIPMENT TECHNICAL PUBLICATIONS

**SOMETHING WRONG WITH THIS PUBLICATION?**



THEN... JOT DOWN THE DOPE ABOUT IT ON THIS FORM. CAREFULLY TEAR IT OUT. FOLD IT AND DROP IT IN THE MAIL!

FROM: (PRINT YOUR UNIT'S COMPLETE ADDRESS)

DATE SENT

PUBLICATION NUMBER

TM 9-4910-586-14&P

PUBLICATION DATE

31 Dec 79

PUBLICATION TITLE

Stand, Transport, Engine

BE EXACT... PIN-POINT WHERE IT IS

PAGE NO.

PARA-GRAPH

FIGURE NO.

TABLE NO.

IN THIS SPACE TELL WHAT IS WRONG AND WHAT SHOULD BE DONE ABOUT IT:

TEAR ALONG PERFORATED LINE

PRINTED NAME, GRADE OR TITLE, AND TELEPHONE NUMBER

SIGN HERE:

FILL IN YOUR  
UNIT'S ADDRESS

FOLD BACK

DEPARTMENT OF THE ARMY

POSTAGE AND FEES PAID  
DEPARTMENT OF THE ARMY  
DOD 314



OFFICIAL BUSINESS  
PENALTY FOR PRIVATE USE \$300

Commander  
US Army Armament Materiel Readiness Command  
ATTN: DRSAR-MAS  
Rock Island, IL 61299

TEAR ALONG PERFORATED LINE



FILL IN YOUR  
UNIT'S ADDRESS

FOLD BACK

DEPARTMENT OF THE ARMY

---

---

OFFICIAL BUSINESS  
PENALTY FOR PRIVATE USE \$300

POSTAGE AND FEES PAID  
DEPARTMENT OF THE ARMY  
DOD 314



TEAR ALONG PERFORATED LINE

Commander  
US Army Armament Materiel Readiness Command  
ATTN: DRSAR-MAS  
Rock Island, IL 61299

RECOMMENDED CHANGES TO EQUIPMENT TECHNICAL PUBLICATIONS



THEN... JOT DOWN THE DOPE ABOUT IT ON THIS FORM, CAREFULLY TEAR IT OUT, FOLD IT AND DROP IT IN THE MAIL!

**SOMETHING WRONG WITH THIS PUBLICATION?**

FROM: (PRINT YOUR UNIT'S COMPLETE ADDRESS)

DATE SENT

PUBLICATION NUMBER

TM 9-4910-586-14&P

PUBLICATION DATE

31 Dec 79

PUBLICATION TITLE

Stand, Transport, Engine

BE EXACT... PIN-POINT WHERE IT IS

PAGE NO

PARA-GRAPH

FIGURE NO.

TABLE NO.

IN THIS SPACE TELL WHAT IS WRONG AND WHAT SHOULD BE DONE ABOUT IT:

TEAR ALONG PERFORATED LINE

PRINTED NAME, GRADE OR TITLE, AND TELEPHONE NUMBER

SIGN HERE:

FILL IN YOUR  
UNIT'S ADDRESS

FOLD BACK

DEPARTMENT OF THE ARMY

POSTAGE AND FEES PAID  
DEPARTMENT OF THE ARMY  
DOD 314



OFFICIAL BUSINESS  
PENALTY FOR PRIVATE USE \$300

Commander  
US Army Armament Materiel Readiness Command  
ATTN: DRSAR-MAS  
Rock Island, IL 61299

TEAR ALONG PERFORATED LINE



**TM 9-4910-586-14&P STAND, TRANSPORT, ENGINE - 1979**



This fine document...

Was brought to you by me:



## [Liberated Manuals -- free army and government manuals](#)

Why do I do it? I am tired of sleazy CD-ROM sellers, who take publicly available information, slap “watermarks” and other junk on it, and sell it. Those masters of search engine manipulation make sure that their sites that sell free information, come up first in search engines. They did not create it... They did not even scan it... Why should they get your money? Why are not letting you give those free manuals to your friends?

I am setting this document FREE. This document was made by the US Government and is NOT protected by Copyright. Feel free to share, republish, sell and so on.

I am not asking you for donations, fees or handouts. If you can, please provide a link to [liberatedmanuals.com](http://liberatedmanuals.com), so that free manuals come up first in search engines:

<A HREF=<http://www.liberatedmanuals.com/>>Free Military and Government Manuals</A>

- Sincerely  
Igor Chudov  
<http://igor.chudov.com/>
- [Chicago Machinery Movers](#)