

OPERATOR'S MANUAL I-SHIFT TRANSMISSION

Volvo Trucks. Driving Success.®



Table of Contents

i

Foreword	1
Safety Information	2
Volvo I-Shift Transmission	4
General Information	4
Gear Selector	6
I-Shift Transmission Features	9
Starting and Stopping	14
Driving	15
Towing	22
Maintenance	22
Index	27

This manual contains information concerning the safe operation of your vehicle. It is extremely important that this information is read and understood before the vehicle is operated. Please keep this manual in the vehicle at all times.

NOTE

It is important that this manual stays with the vehicle when it is sold. Important safety information must be passed on to the new customer.

NOTE

Illustrations in this manual are used for reference only and may differ slightly from the actual vehicle, however, key components addressed in the manual are represented as accurately as possible.

All information, illustrations and specifications contained in this manual are based upon the latest product information available at the time of publication. Volvo Trucks North America reserves the right to make changes at any time or to change specifications or design without notice and without incurring obligation.

The National Highway Traffic Safety Administration (NHTSA) and Volvo Trucks North America should be informed immediately if you believe that the vehicle has a defect that could cause a vehicle accident, injury or death.

Contact NHTSA by calling the Auto Safety Hotline at 1 (888) 327-4236, by writing to NHTSA, U.S. Department of Transportation, Washington, DC 20590, by TTY at 1 (800) 424-9153, or visit their website at www.nhtsa.dot.gov.

Volvo Trucks North America

Greensboro, NC USA

Order number: PV776-20906026

© Volvo Group North America, Inc. 2007. All Rights Reserved.

No part of this publication may be reproduced, stored in retrieval system, or transmitted in any forms by any means, electronic, mechanical, photocopying, recording or otherwise, without the prior written permission of Volvo Trucks North America.

SAFETY INFORMATION

IMPORTANT: Before driving this vehicle, be certain that you have read and that you fully understand each and every step of the driving and handling information in this manual. Be certain that you fully understand and follow all safety warnings. It is extremely important that this information is read and understood before the vehicle is operated.

IT IS IMPORTANT THAT THE FOLLOWING INFORMATION BE READ, UNDERSTOOD AND ALWAYS FOLLOWED.

The following types of advisories are used throughout this manual:

 **DANGER**

A danger directs the operator's attention to unsafe practices which could result in serious personal injury or death. The danger title is in white type on a black background.

 **WARNING**

A warning directs the operator's attention to unsafe practices which could result in personal injury. The warning title is in black type on a gray background.

 **CAUTION**

*A caution directs the operator's attention to unsafe practices where property damage could occur. The caution title is in **black** type on a **white** background.*

NOTE

A note defines an operating procedure, practice, condition, etc., which is essential to proper operation of the vehicle.

Labels

Danger, Warning, Caution and Advisory labels are placed in various locations on the vehicle to alert drivers and service technicians about situations that may lead to personal injury or equipment damage. In the event that a label is damaged or missing the **label must be replaced**. Contact your authorized Volvo Truck dealer for assistance regarding labels.

I-Shift Transmission Labels

There are labels with operating information about the I-Shift transmission located on the driver's side sun visor. It is extremely important that this information is read and understood before the vehicle is operated.

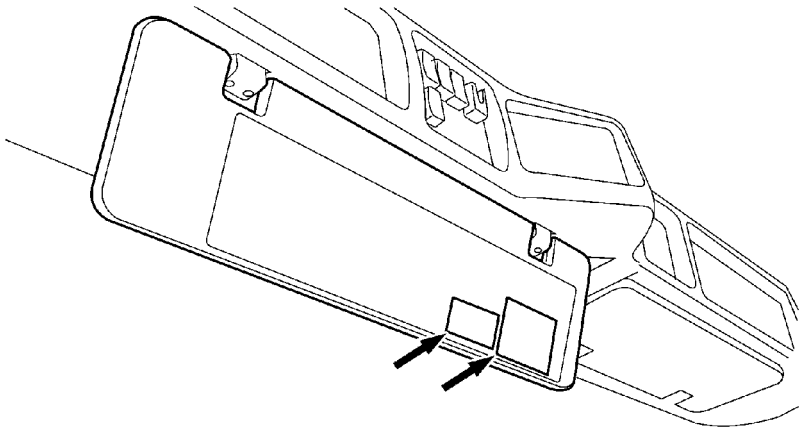

I-Shift Transmission Sun Visor Labels Location

GENERAL INFORMATION

The Volvo I-Shift transmission is a single countershaft transmission with 12 forward gears and two reverse gears. Some vehicles have four reverse gears. The I-Shift is an automated **mechanical** transmission. The transmitted torque (both engine and braking) will be interrupted during gear shifting, in both driving and coasting conditions. There is no clutch pedal and the gearshift is controlled by the ergonomic gear selector. The I-Shift is available as an overdrive or direct drive transmission.

Nomenclature and Ratios

The I-Shift transmission is available in four configurations:

- AT2512C – Direct Drive for Volvo D11 and D13 Engines
- ATO2512C – Overdrive for Volvo D11 and D13 Engines
- AT2812C – Direct Drive for Volvo D16 Engine
- ATO3112C – Overdrive for Volvo D16 Engine

NOMENCLATURE

AT	O	XX	12	C
Automated Mechanical Transmission	O = Overdrive No Letter = Direct Drive	Maximum Input Torque Nm (lb-ft) 25 = 2500 (1850) 28 = 2800 (2050) 31 = 3100 (2300)	Forward Speeds	Design Level

GEAR RATIOS

Gear Selection	AT2512C and AT2812C	ATO2512C and ATO3112C
1st	14.94:1	11.73:1
2nd	11.73:1	9.21:1
3rd	9.04:1	7.09:1
4th	7.09:1	5.57:1
5th	5.54:1	4.35:1
6th	4.35:1	3.41:1
7th	3.44:1	2.70:1
8th	2.70:1	2.12:1
9th	2.08:1	1.63:1
10th	1.63:1	1.28:1
11th	1.27:1	1.00:1
12th	1.00:1	0.78:1
Reverse Gear R1	17.48:1	13.73:1
Reverse Gear R2	13.73:1	10.78:1
Reverse Gear R3	4.02:1	3.16:1
Reverse Gear R4	3.16:1	2.48:1

Identification Tag

Each transmission has two identification tags. One is on the top of the clutch housing and the other is on the back of the range housing. Write the serial number in the space provided below.

Serial Number _____

Display

The Driver Information Display (DID) in the instrument cluster provides current operating information about the I-Shift transmission. The I-Shift information is always displayed in a portion of the DID.

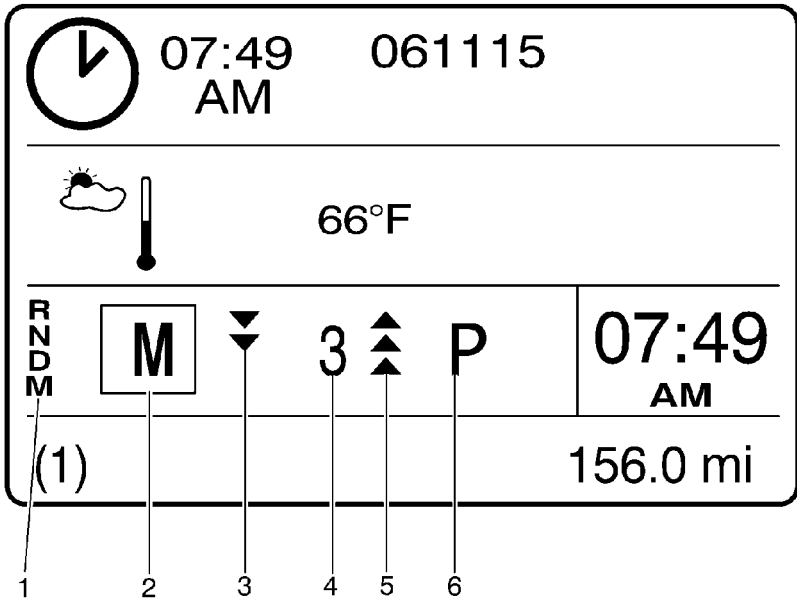

Driver Information Display with I-Shift Transmission

- | | |
|--|---|
| <ol style="list-style-type: none"> Gear Selector Pattern is shown in the display so the driver does not have to look down at the gear selector to determine which way to move the gear lever to obtain a different gear range. Selected Gear Position indicates the current position of the gear lever. Available Gears Down indicates the number of downshifts with the current vehicle operating conditions. | <ol style="list-style-type: none"> Current Gear indicates the current transmission operating gear. Available Gears Up indicates the number of upshifts with the current vehicle operating conditions. Driving Mode indicates if the transmission is operating in Economy or Performance mode. |
|--|---|

GEAR SELECTOR

Two gear selectors are available with the I-Shift transmission: Premium and Basic. The gear selector is attached to the driver's seat. There are four gear selector positions: R, N, D and M. When the gear lever is in the R position, the reverse gears are engaged. The N position places the transmission in neutral. The D position is the automatic drive mode. With the Premium gear selector, the M position allows the driver to manually select the operating and starting gear. With the Basic gear selector, the M position holds the current operating gear and puts the transmission in first gear when starting from a stop.

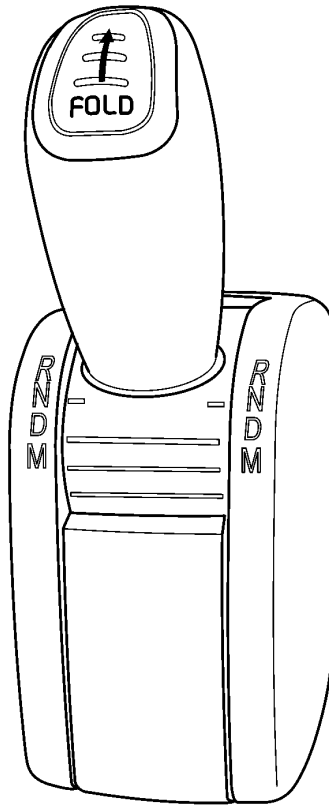

Basic Gear Selector Shown

The gear selector lock must be depressed to move the gear lever from the N position. The gear lever can be moved from the R position to N, back and forth between the D and M positions, and from the D position to N without pressing the gear selector lock.

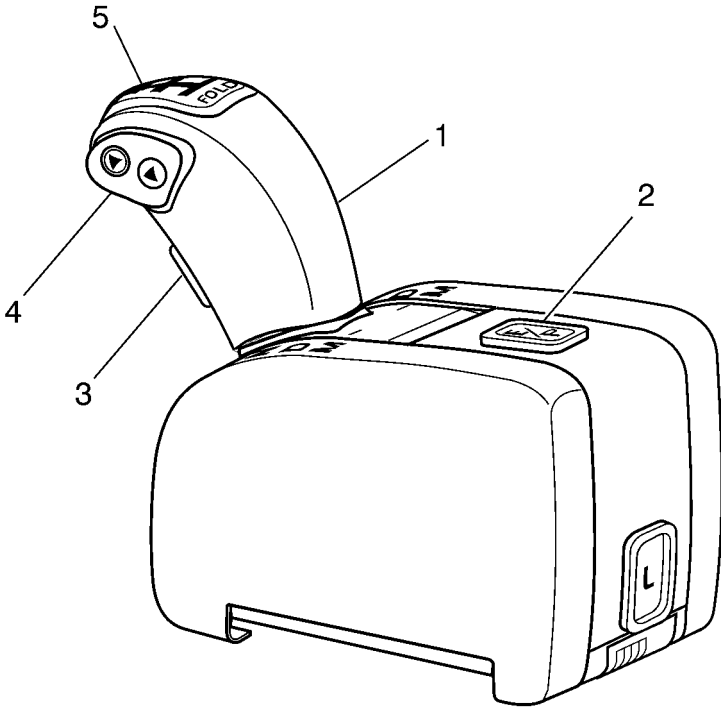

Premium Gear Selector Shown

1. Gear Lever	4. Manual Gear Selection Buttons (Premium gear selector only)
2. Economy/Performance Button (Premium gear selector only)	5. Fold Button
3. Gear Selector Lock	

With the Premium gear selector, the manual gear selection buttons allow the operator to manually select the operating gear in both the automatic and manual driving modes. Also, the operator can use the manual gear selection buttons to select the vehicle start gear and the idle driving gear.

Premium gear selectors have an Economy/Performance button. The transmission is in Economy mode when the vehicle is started. Press the E/P button to enable Performance mode.

The gear lever can be folded to the horizontal position by depressing the Fold button on the top of the lever. It is not necessary to press the Fold button again to return the gear lever to the vertical position. The gear lever is in the N position when returned to the vertical position.

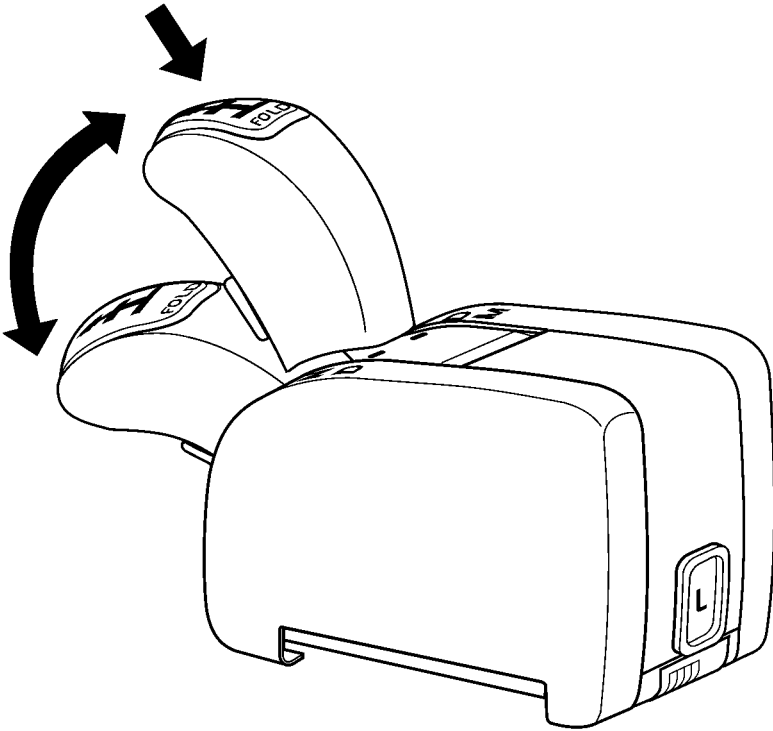

Gear Lever Horizontal and Vertical Positions

When the gear lever is in the horizontal or folded position, F is displayed as the gear range and the installed feature package is displayed as the driving mode in the DID. The installed feature package can be modified by customer parameters in the software. Contact your Volvo Truck dealer for more information about the optional feature packages listed below:

- B = Basic
- EB = Enhanced Basic
- FE = Fuel Economy
- P = Performance
- CO = Comprehensive

I-SHIFT TRANSMISSION FEATURES

<h3>NOTE</h3>

The I-Shift transmission is available with optional feature packages. Customer-requested options allow these packages to be modified to meet specific operating conditions. Contact your Volvo Truck dealer for more information about standard and optional features.

I-Shift transmission optional feature packages can be upgraded to add additional benefits. The following features are available.

Economy and Performance Modes

When the engine is started, the transmission is in Economy mode. An E is displayed as the driving mode in the DID. The transmission automatically selects shift points and engine parameters to maximize fuel economy. Economy mode is primarily used when driving under normal conditions.

In Performance mode, a P is displayed as the driving mode in the DID. The transmission maximizes gradeability. Performance mode is designed for use in vocational and specialty vehicles such as construction and heavy haul.

Customer-requested options allow the Performance mode to be modified to meet specific operating conditions. Options include full operator control, no operator control and automatic return to Economy mode under certain operating conditions. A customer-requested option is available to disable the Kick-Down function when the transmission is operating in Performance mode. Contact your Volvo Truck dealer for more information about standard and optional features.

The Performance Mode feature can also be enabled by the Volvo Performance Bonus software package to reward the driver for saving fuel.

<h3>NOTE</h3>

Operating the vehicle in Performance mode for extended periods can result in a loss of fuel economy.

Kick-Down

When the Kick-Down switch on the accelerator pedal is engaged, the transmission will optimize vehicle acceleration, which may result in a downshift. Kick-Down is engaged by pressing the accelerator pedal all the way down to the floor. The gear selector must be in the D position to engage Kick-Down. Kick-Down disables when the accelerator pedal is lifted. The Kick-Down function can be enabled or disabled based on customer preference. The Kick-Down feature can also be enabled by the Volvo Performance Bonus software package to reward the driver for saving fuel.

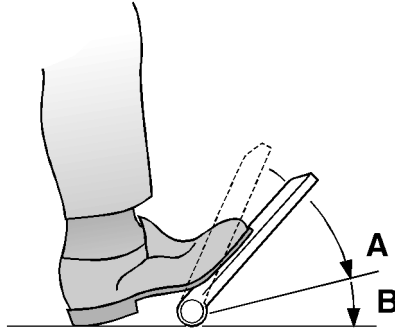
**Kick-Down Switch**

A = 100% Throttle

B = Kick-Down

NOTE

Operating the vehicle with Kick-Down engaged for extended periods can result in a loss of fuel economy.

Engine Brake Performance Mode

NOTE

When the Volvo engine brake is active and transmission is shifting gears, there will be a momentary interruption of the braking torque. This may result in a temporary increase of vehicle speed. The operator will experience the same momentary loss of engine braking as is experienced when downshifting a conventional manual transmission.

Volvo's enhanced engine brake (I-VEB) is standard with I-Shift transmissions. The current brake position is displayed in the status bar in the DID. The switch on the end of the 6-position engine brake control sets and changes the set speed for the engine brake.

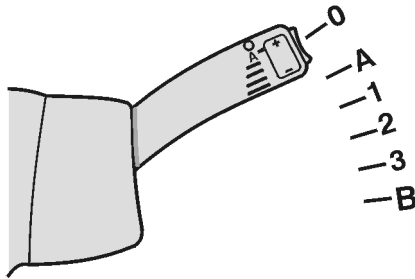

Brake Control Positions

When cruise control is set, move the engine brake control to the A position and set the brake cruise speed with the set switch to maintain the set speed. The transmission interacts with the engine brake to provide optimum performance.

When the vehicle is operated in Engine Brake Performance Mode, the transmission selects the gear with the highest level of braking and keeps engine speed above 1500 rpm. The Engine Brake Performance Mode is activated by moving the brake control to the B position and holding the control in the B position for at least 1 second. When the control is moved to the B position, B is displayed in the status bar in the DID. When Engine Brake Performance Mode is engaged, B is displayed in the driving mode in the DID.

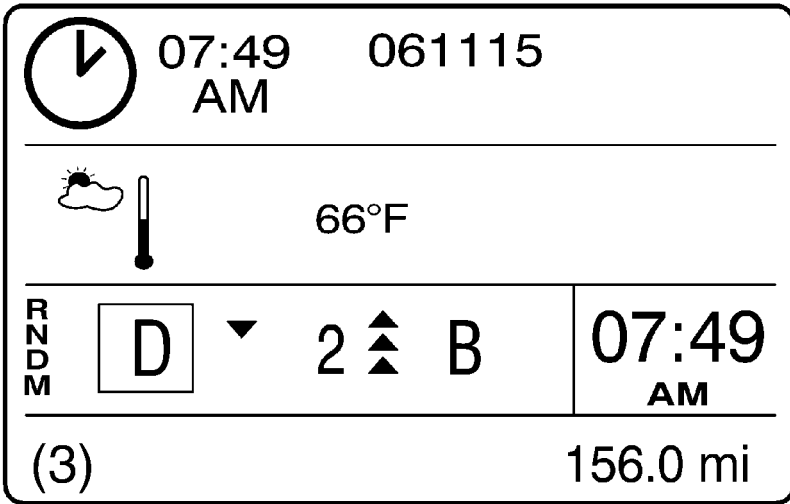

Engine Brake Position Display

Engine Idle Governor Driving Mode

The Engine Idle Governor driving mode (if equipped) allows slow speed vehicle maneuvering such as at the loading dock or in slow moving traffic. This feature operates the engine at idle while the operator selects a gear to adjust the vehicle speed. The automatic clutch remains closed and there is no slipping or overheating. The idle governor will adjust the torque to maintain idle speed and constant vehicle speed, although the engine load may vary. Tapping the service brake will cause the transmission to shift down one gear, if necessary. With the Premium gear selector, it is also possible to downshift using the manual gear selection buttons. Press the accelerator pedal to increase vehicle speed. The clutch is only disengaged when the vehicle is stopped or the brake pedal is fully applied.

Transmission Power Take-Off (PTO)

Basic PTO functions include pre-defined splitter positions. Parameters that define which splitter gear to engage when transmission Power Take-Off 1 and 2 are engaged can be adjusted.

With the Premium gear selector, when the gear lever is in the N position, the operator can use the manual gear selection buttons to select the split gear when using the power take-off.

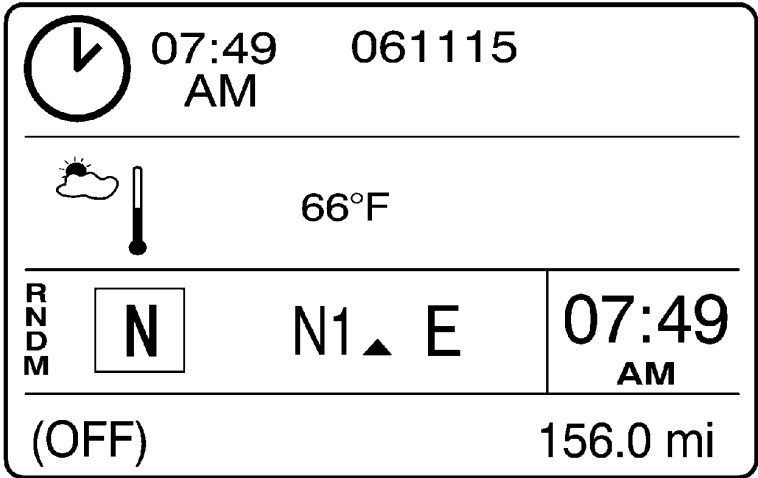

N Position Display

STARTING AND STOPPING

Starting

The transmission gear lever must be in the N position or the engine will not start. If the gear lever is not in neutral, a starter protection message will appear in the DID along with the Information light and an audible warning.

If there is not enough air pressure in the I-Shift air reservoir, a low air supply message will appear in the DID along with the Information light and an audible warning. Start the engine and allow the air pressure to build in the reservoir. Wait until the message and light go off before attempting to shift the transmission into gear.

The gear selector lock must be depressed to move the gear lever from the N position. Also the brake pedal must be pressed down. If the brake pedal is not pressed down before attempting to move the gear lever from the N position, a brake interlock message will appear in the DID along with the Information light and an audible warning. Move the gear lever back to the N position, apply the brake pedal and move the gear lever to the desired gear.

With the Premium gear selector, the operator can always select a lower start gear in both the D and M position. Also, the operator can always select a higher start gear in the R position.

Stopping



When parking the vehicle, always apply the parking brake and move the gear lever to the N position on the gear selector. Make sure the parking brake is holding the vehicle before leaving the driver position. Failure to do so can result in unexpected vehicle movement and can cause serious personal injury or death.

When the vehicle is stopped:

1. Apply the parking brake.
2. Move the gear lever to the N position on the gear selector.
3. Switch off the engine.

DRIVING

The most efficient way to operate the vehicle is to use the automatic drive program, the D position on the gear selector. Gear changing is automatic and the operator can concentrate on the road ahead. With the Premium gear selector, the operator has limited ability to change gears manually with the gear selector in the D position. In addition, the brake control switch should be in the A position to maximize the integration of the transmission and brake system. This means optimum performance and fuel economy at all times.

When the gear selector is in the D position and the engine speed is below 1500 rpm, moving the brake control to the B position will cause the transmission to downshift. Move the gear lever to the M position to hold the transmission in the newly selected gear.

In difficult driving conditions such as forests, construction sites and off-road, manual mode, the M position on the gear selector, and Performance Mode (if equipped), give the operator more control.

NOTE

When changing gears manually, the accelerator pedal should not be released.

D Position

When the Premium gear selector lever is in the D position, the current transmission operating gear is displayed along with up and down arrows on each side of the gear display. These arrows indicate the number of available manual upshifts or downshifts based on the current driving conditions. The operator can use the manual gear selection buttons to upshift or downshift as indicated by the arrows. The transmission will automatically upshift and downshift as necessary to maintain the desired vehicle speed for the current driving conditions. The number of available manual upshifts and downshifts will change as driving conditions change.

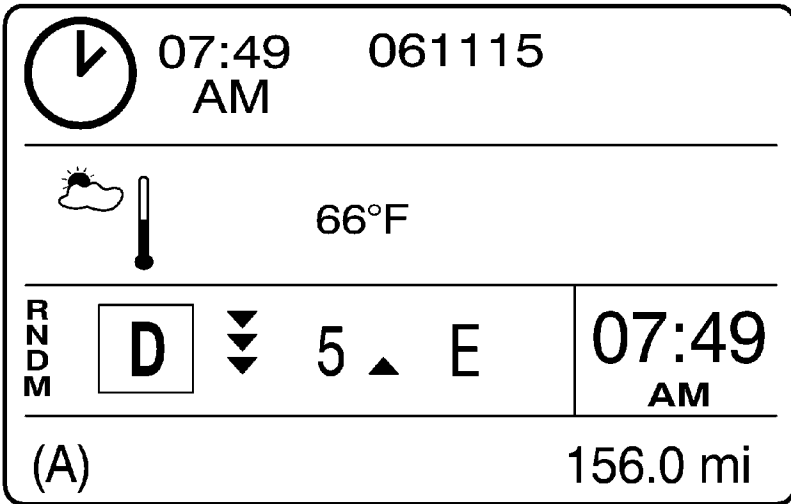

D Position Display

NOTE

Press the manual gear selection buttons multiple times to “skip shift” or jump up or down more than one gear at a time (three gears maximum).

M Position

When the Premium gear selector lever is in the M position, the current gear is displayed along with the up and down arrows. The transmission will not automatically change gears as the driving conditions change. The operator can use the manual gear selection buttons to upshift or downshift manually. The number of available upshifts and downshifts will change as driving conditions change.

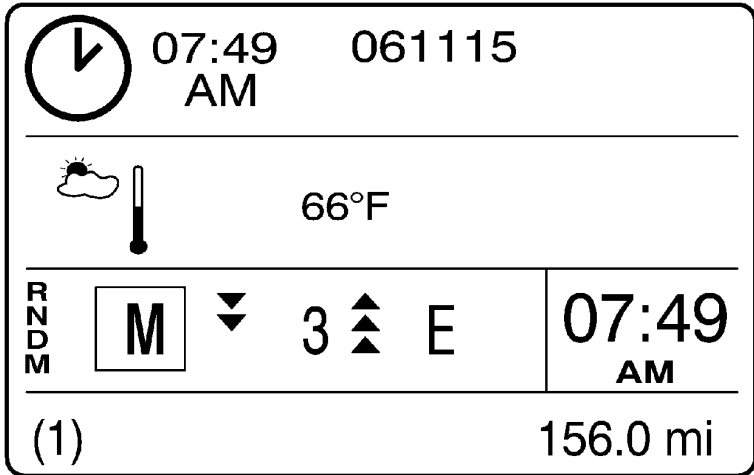

M Position Display

CAUTION

Starting the vehicle in too high a gear causes excessive wear to the clutch and can result in clutch damage.

With the Premium gear selector, when the vehicle is stationary, the gear lever is in the M position and the transmission has detected conditions that require a lower vehicle start gear, a select lower gear message will appear in the DID along with the Information light and an audible warning. Move the gear lever to the D position on the gear selector, or use the manual gear selection button to select a lower start gear. If necessary, continue to use the manual gear selection button to select lower start gears until the message and light go off.

With the Basic gear selector, when the vehicle is stationary and the gear lever is moved from the D position to M, the vehicle start gear will change to first.

NOTE

There is the risk of over-revving the engine when the transmission is locked in a gear. Damage to the engine may occur.

To lock the transmission in the current gear, move the gear lever from the D position to the M position. This function can be used for all 12 forward gears. To return to the automatic program, move the gear lever back to the D position.

NOTE

Operating the vehicle in the M position for extended periods can result in a loss of fuel economy.

R Position

When the Premium gear selector lever is in the R position, the current gear is displayed along with the up and down arrows. The transmission will not automatically change gears as the driving conditions change. The operator can use the manual gear selection buttons to upshift or downshift manually. If the vehicle has four reverse gears, the vehicle must be stationary to shift between reverse gear R2 and reverse gear R3.

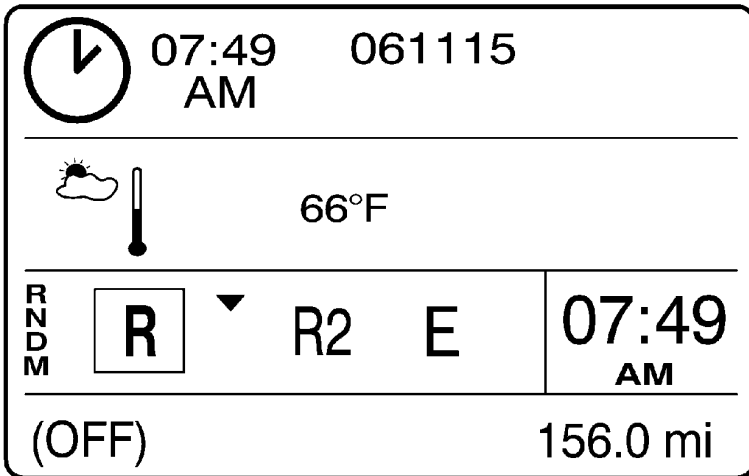

R Position Display

With the Basic gear selector, when the vehicle is moving and the gear lever is moved from the D or R position to M, the transmission will stay in the current gear until the lever is moved back to D, R or N.

Starting the Vehicle Uphill and Downhill

DANGER

The vehicle can roll when stopped on a hill or grade, or when the vehicle is starting from a stop on a hill or grade. Always use the brakes to hold the vehicle stationary on a hill or grade. Failure to do so can result in serious personal injury or death.

CAUTION

Always use the brakes to hold the vehicle stationary on a uphill stop. Never hold the vehicle stationary on an uphill slope using the accelerator pedal. The clutch could overheat, which could cause it to breakdown.

The I-Shift transmission clutch is a dry disc type, with **no torque converter**. Never allow the clutch to slip in too high a gear when starting the vehicle. If the clutch overheats, a high clutch load message or clutch protection active message will appear in the DID along with the Check light and an audible warning.

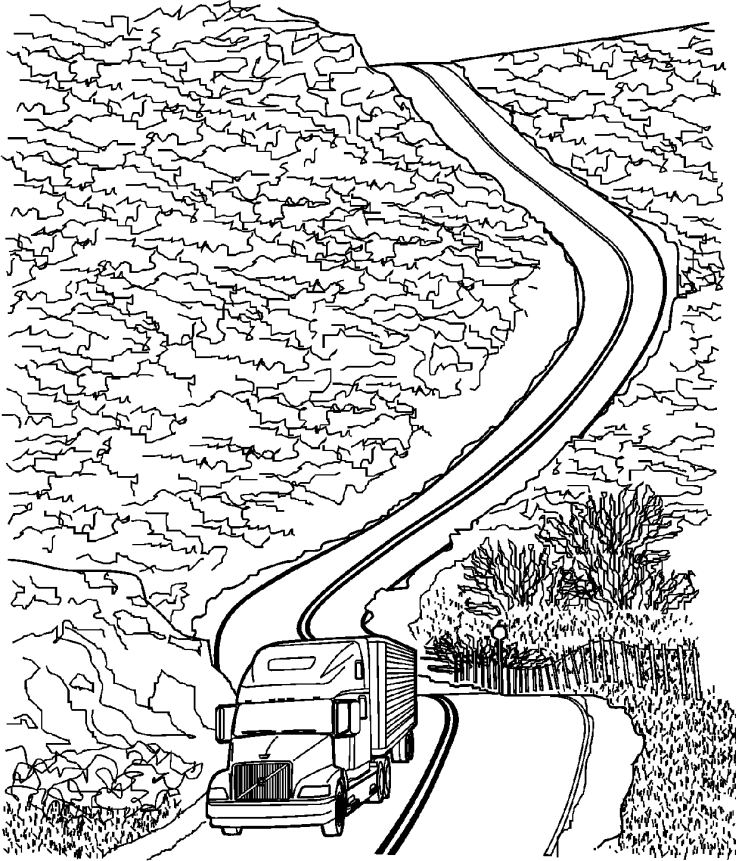

Hilly Operating Conditions

When starting the vehicle on an uphill slope:

1. Press the brake pedal.
2. Move the gear lever to the D position on the gear selector. With the Premium gear selector, the operator can use the manual gear selection button to select a lower start gear.
3. Quickly move your foot from the brake pedal and firmly press the accelerator pedal.

Limp Home Mode

NOTE

Limp Home Mode should only be used to move the vehicle to a safe location. Only use Limp Home Mode when no other way to move the vehicle is available.

If the transmission has a mechanical problem, press the L button on the gear selector and move the gear lever to the D position to activate Limp Home Mode. When activated, L is displayed as the driving mode in the DID. With the Premium gear selector, only 1st, 3rd and 5th forward start gears and reverse gear R1 are available. With the Basic gear selector, only 1st forward start gear and reverse gear R1 are available. The operator cannot change gears in Limp Home Mode. The Limp Home Mode will be deactivated when the ignition is turned off.

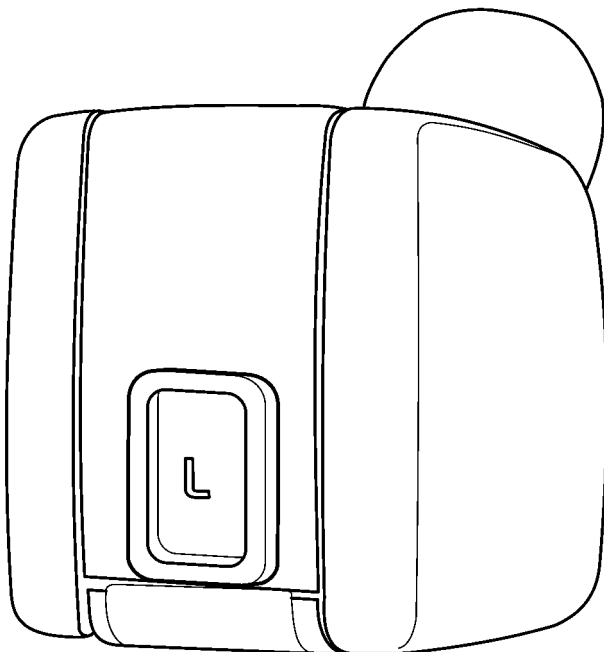

Limp Home Mode Button

TOWING** CAUTION**

You must tow a vehicle equipped with an I-Shift transmission according to the guidelines below. Failure to do so can result in damage to transmission components.

When towing the vehicle, the output shaft of the transmission must not be allowed to spin or turn. If the vehicle is towed with the drive wheels still in contact with the road surface, the vehicle axle shafts or driveline must be removed or disconnected.

MAINTENANCE** DANGER**

Before working on or inspecting a vehicle, set the parking brakes, place the transmission in neutral and chock the wheels. Failure to do so can result in unexpected vehicle movement and can cause serious personal injury or death.

 DANGER

Do not attempt to repair or service this vehicle without having sufficient training, the correct service literature and the proper tools. Failure to follow this could make your vehicle unsafe and lead to serious personal injury or death.

Drain the moisture from the transmission air reservoir daily. Draining the moisture from the air reservoir helps prevent moisture and contaminants from entering the transmission. Moisture in the transmission can affect operation and damage components.

Transmission Oil

 **CAUTION**

Only use Volvo approved synthetic oil in the I-Shift transmission. Using non-approved oil can result in damage to transmission components.

Keep the transmission oil at the proper level and change it at the Volvo recommended intervals. Always replace the oil filter when the oil is changed. Always use the Volvo approved synthetic oil whenever adding or changing the transmission oil.

For a complete list of approved oils, contact your Volvo Truck dealer. Also, refer to Bulletin 175-61, *Approved Oils, Volvo Components*.

Check Oil Level

Check the transmission oil level at each service interval. Park the vehicle on a level surface. Check the oil level through the sight glass on the side of the transmission. Add oil as necessary. Always use the correct Volvo approved synthetic oil.

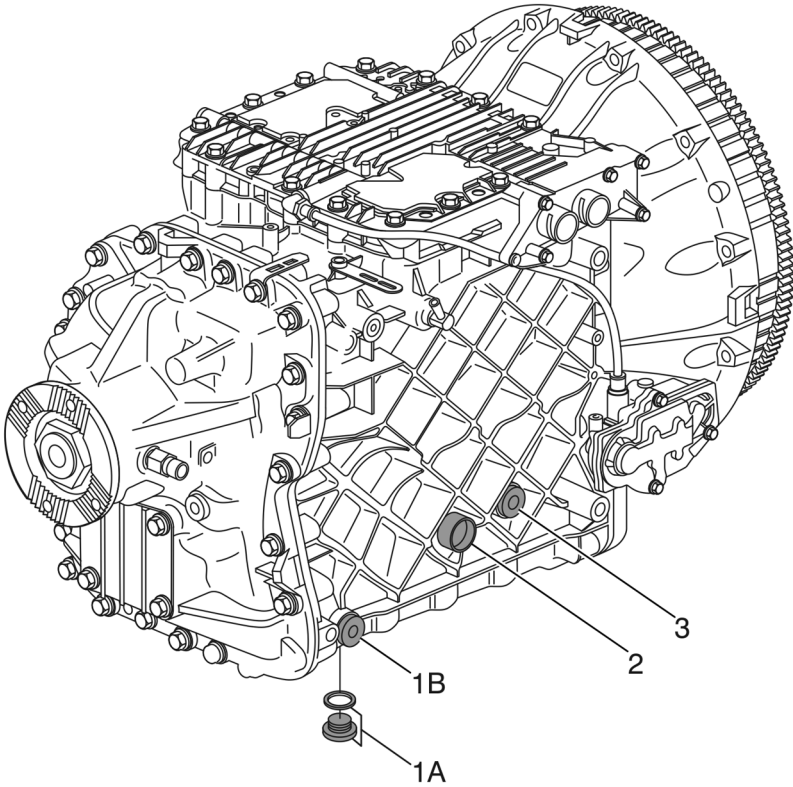

1. Drain Plug	2. Sight Glass	3. Fill Plug and Oil Level
---------------	----------------	----------------------------

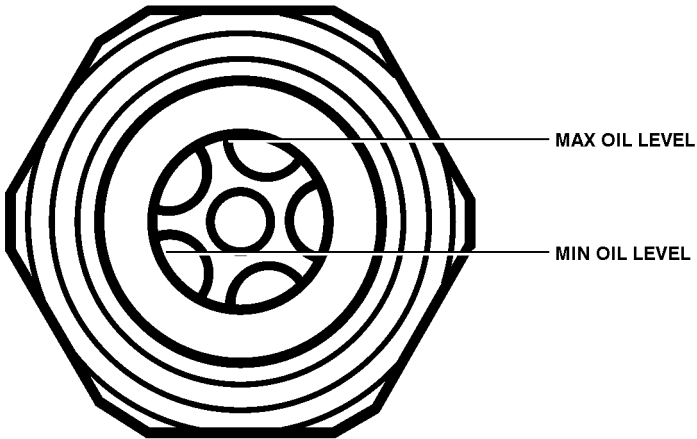

Sight Glass for Checking Oil Level

Oil Change Interval

The length of time a transmission can operate before an oil change is required depends on the quality of the oil used and the vehicle application. For severe service or off-highway applications, more frequent oil changes may be necessary.

For on-highway applications, change the transmission oil every 400 000 km (250,000 miles). Always replace the oil filter when the oil is changed. Always use the Volvo approved synthetic oil whenever changing the transmission oil.

For additional information about oil change intervals, contact your Volvo Truck dealer. Also, refer to Bulletin 175-60, *Oil and Filters, Volvo Components*.

Oil Change

W A R N I N G

Hot oil can cause burns. DO NOT allow hot oil to contact the skin. When changing oil, wear protective gloves.

C A U T I O N

Always dispose of all lubricants (engine oil, coolant, transmission oil, etc) and filters according to Federal or local regulations. Used oil disposed of in nature or waterways contaminates our drinking water and kills wildlife.

Change the oil filter at every oil change. Drain the oil filter housing before you remove the filter.

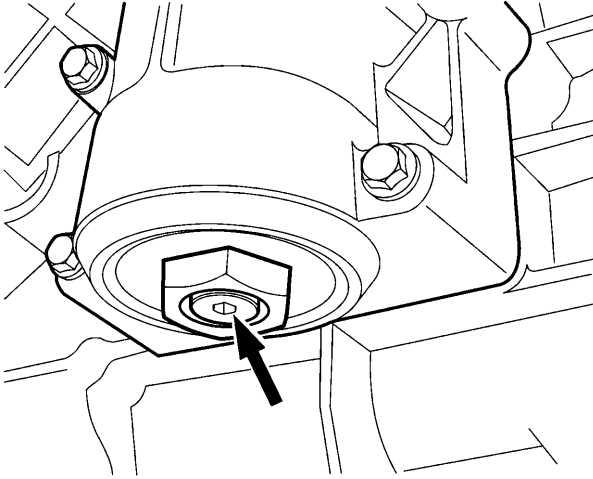

Oil Filter Housing Drain Plug

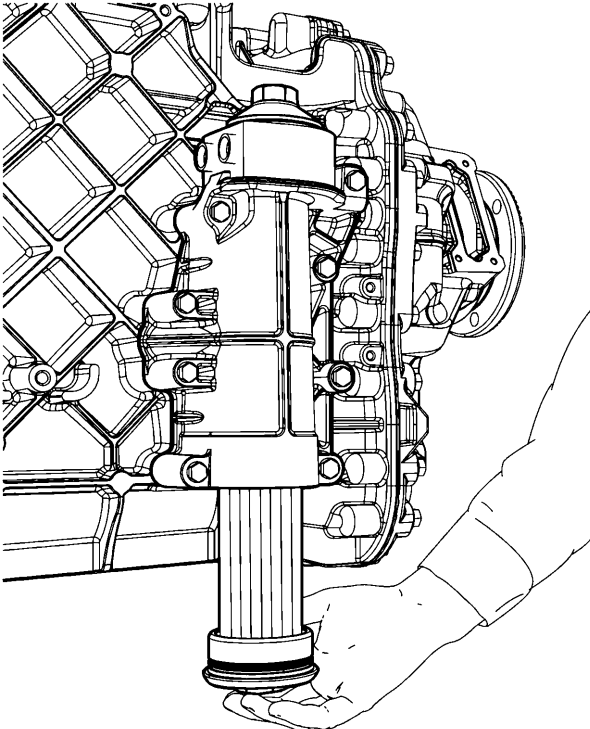

Oil Filter

C

Check Oil Level 23

D

Display 5

Driving 15

E

Economy Mode 9

Engine Brake Performance Mode 11

G

Gear Selector 6

General Information 4

I

Identification Tag 5

Idle Governor Driving Mode 12

K

Kick-Down 10

L

Limp Home Mode 21

M

Maintenance 22

N

Nomenclature and Ratios 4

O

Oil Change 25

Oil Change Interval 25

P

Performance Mode 9

S

Starting 14

Starting and Stopping 14

Stopping 15

T

Towing 22

Transmission Oil 23

Transmission Power Take-Off (PTO) 13

V

Volvo Engine Brake (I-VEB) 11

1-800-52-VOLVO

Volvo Action Service (VAS) Support Center

- If you need assistance on the road or if you need service repairs, contact the VAS support center. VAS is available 24 hours per day, 7 days per week at **1-800-528-6586**.
- Please report the specific nature of the service problem to the Volvo Customer Support Specialist, who will answer your questions and arrange for the assistance you need.

Truck Model & Serial

Engine Model & Serial

Transmission Model & Serial

Rear Axle Model & Serial

Your Truck Was Delivered By:

VOLVO

Volvo Trucks North America

P.O. Box 26115 Greensboro, NC 27402-6115

Volvo Trucks Canada, Ltd.

5600A Cancross Court, Mississauga, Ontario L5R 3E9

<http://www.volvotrucks.volvo.com>