

Genie®



Operator's Manual

with Maintenance Information

Second Edition
Fifth Printing
Part No. 43650

STM-80

STM-85

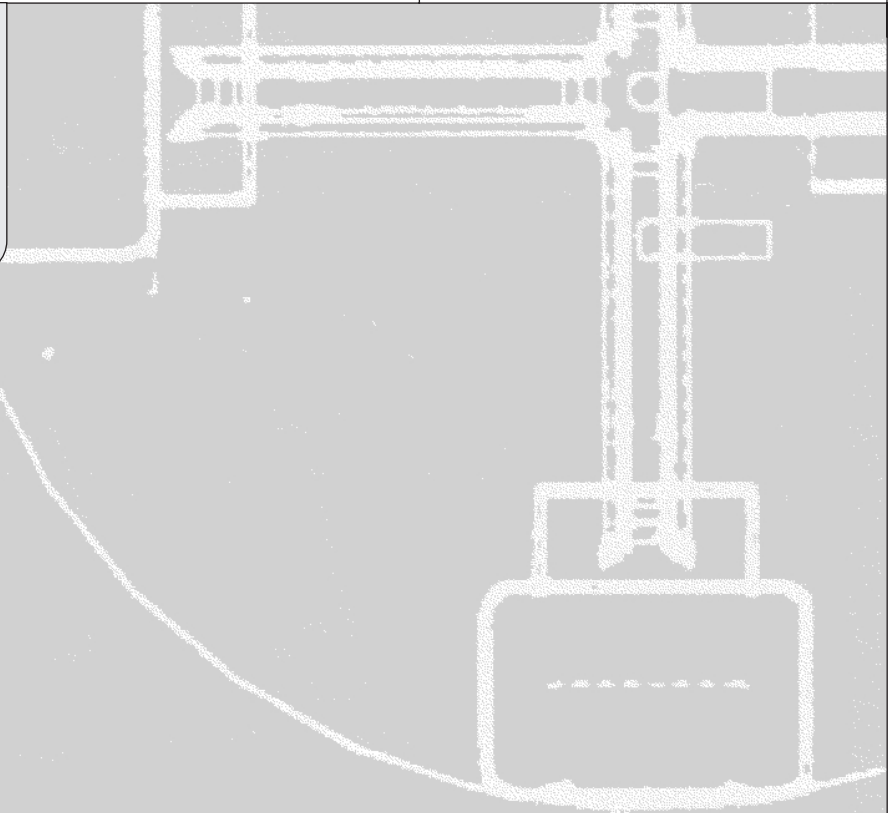

Important

Read, understand and obey these safety rules and operating instructions before operating this machine. Only trained and authorized personnel shall be permitted to operate this machine. This manual should be considered a permanent part of your machine and should remain with the machine at all times. If you have any questions, call Genie Industries.

Contents

| | Page |
|--------------------------------|------|
| Safety Rules | 1 |
| Controls | 7 |
| Pre-operation Inspection | 10 |
| Maintenance | 12 |
| Function Tests | 16 |
| Work Place Inspection | 22 |
| Operating Instructions | 23 |
| Transport Instructions | 27 |
| Decals | 28 |
| Specifications | 30 |

Contact us:

Internet: <http://www.genielift.com>
 e-mail: techpub@genieind.com

Genie Industries

Copyright © 1994 by Genie Industries

First Edition: First Printing, August 1994
 Second Printing, February 1995
 Third Printing, March 1996
 Fourth Printing, September 1996
 Fifth Printing, October 1996

Second Edition: First Printing, November 1996
 Second Printing, March 1997
 Third Printing, March 1998
 Fourth Printing, August 1999
 Fifth Printing, July 2000

"Genie" is a registered trademark of Genie Industries in the U.S.A. and many other countries. "S" is a trademark of Genie Industries.

These machines comply with ANSI/SIA 92.5-1992.

 Printed on recycled paper

Printed in U.S.A.

Safety Rules



Danger

Failure to obey the instructions and safety rules in this manual will result in death or serious injury.

Do Not Operate Unless:

- You learn and practice the principles of safe machine operation contained in this operator's manual.

1 Avoid hazardous situations.

Know and understand the above principle before going on to the next section.

2 Always perform a pre-operation inspection.

3 Always perform function tests prior to use.

4 Inspect the work place.

5 Only use the machine as it was intended.

- You read, understand and obey:

Manufacturer's instructions and safety rules—safety and operator's manuals and machine decals

employer's safety rules and worksite regulations

applicable governmental regulations

- You** are properly trained to safely operate the machine.

SAFETY RULES

Electrocution Hazards

This machine is **not** electrically insulated and will **not** provide protection from contact with or proximity to electrical current.

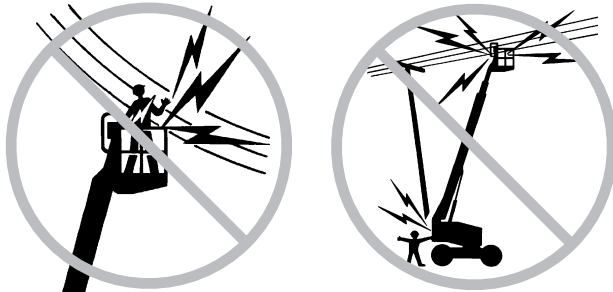

Maintain safe distances from electrical power lines and apparatus in accordance with applicable governmental regulations and the following chart.

| Voltage Phase to Phase | Minimum Safe Approach Distance | |
|---------------------------|-----------------------------------|--------|
| | Feet | Meters |
| 0 to 300V | Avoid Contact | |
| 300V to 50KV | 10 | 3.05 |
| 50KV to 200KV | 15 | 4.60 |
| 200KV to 350KV | 20 | 6.10 |
| 350KV to 500KV | 25 | 7.62 |
| 500KV to 750KV | 35 | 10.67 |
| 750KV to 1000KV | 45 | 13.72 |

Allow for platform movement, electrical line sway or sag and beware of strong or gusty winds.

Keep away from the machine if it contacts energized power lines. Personnel on the ground or in the platform must not touch or operate the machine until energized power lines are shut off.

Do not operate the machine during lightning or storms.

Do not use the machine as a ground for welding.

Tip-over Hazards

Occupants and equipment shall not exceed the maximum platform capacity.

| | | |
|--|---------|--------|
| Maximum platform capacity S-85 | 500 lbs | 227 kg |
| Maximum platform capacity S-80 with 8 Ft Platform | 500 lbs | 227 kg |
| Maximum platform capacity S-80 with 6 Ft Platform | 600 lbs | 272 kg |
| Maximum platform capacity S-80 with 6 Ft Platform with foam-filled tires and proper counterweight configuration | 750 lbs | 340 kg |
| Maximum occupants | 2 | |

SAFETY RULES

Do not raise or extend the boom unless both axles are extended.

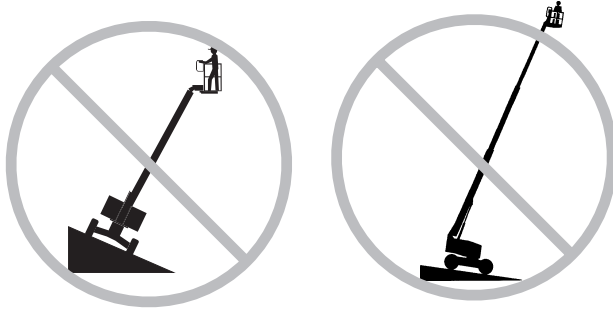

Do not raise or extend the boom unless the machine is on a firm, level surface.

Do not depend on tilt alarm as a level indicator. Tilt alarm sounds in platform only when machine is on a severe slope.

If tilt alarm sounds:

Do not extend, rotate or raise boom above horizontal. Move machine to a firm, level surface before raising platform. If tilt alarm sounds when platform is raised, use extreme caution to retract boom and lower platform. Do not rotate boom while lowering. Move machine to a firm, level surface before raising platform.

Do not operate the machine in strong or gusty winds. Do not increase the surface area of the platform or the load. Increasing the area exposed to the wind will decrease machine stability.



Use extreme care and slow speeds while driving the machine in stowed position across uneven terrain, debris, unstable or slippery surfaces and near holes and drop-offs.

Do not drive the machine on or near uneven terrain, unstable surfaces or other hazardous conditions with the boom raised or extended.

Do not push off or pull toward any object outside of the platform.

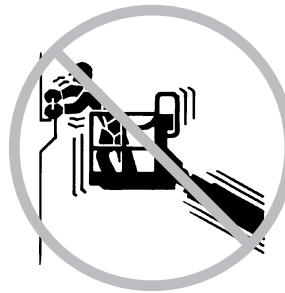

Maximum allowable side force-ANSI & CSA
150 lbs
667 N

Maximum allowable manual force - CE
90 lbs
400 N

Do not alter or disable machine components that in any way affect safety and stability.

Do not replace items critical to machine stability with items of different weight or specification.

Do not modify or alter an aerial work platform. Mounting attachments for holding tools or other materials onto the platform, toeboards or guard rail system can increase the weight in the platform and the surface area of the platform or the load.

SAFETY RULES

Do not place or attach overhanging loads to any part of this machine.

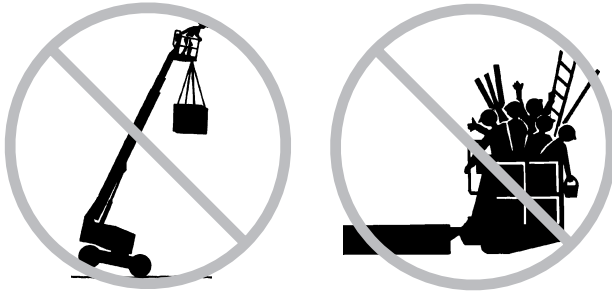

Do not place ladders or scaffolds in platform or against any part of this machine.

Do not use machine on a moving or mobile surface or vehicle.

Be sure all tires are in good condition, air-filled tires are properly inflated and lug nuts are properly tightened.

Models with 750 lb (340 kg) Capacity: Do not use air-filled tires. Models are equipped with foam-filled tires. The wheel weight and the proper counterweight configuration are critical for machine stability.

Do not use the platform controls to free a platform that is caught, snagged or otherwise prevented from normal motion by an adjacent structure. All personnel must be removed from the platform before attempting to free the platform using the ground controls.

Fall Hazards



Occupants must wear a safety belt or harness in accordance with governmental regulations. Attach lanyard to anchor provided in platform.

Do not sit, stand or climb on the platform guard rails. Maintain a firm footing on the platform floor at all times.

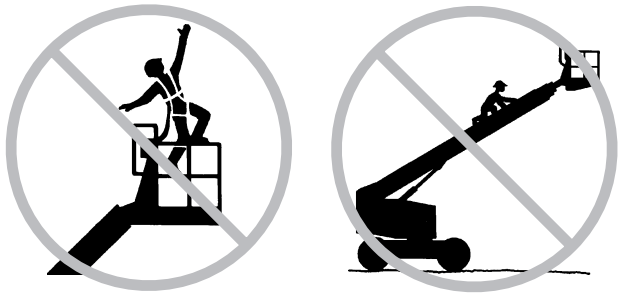

Do not climb down from the platform when raised.

Keep the platform floor clear of debris.

Lower the platform entry mid-rail or close the entry gate before operating.

Bodily Injury Hazard

Do not operate the machine with a hydraulic oil or air leak. An air or hydraulic leak can penetrate and/or burn skin.

Always operate machine in a well-ventilated area to avoid carbon monoxide poisoning.

SAFETY RULES

Collision Hazards

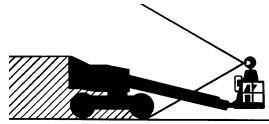

Be aware of limited sight distance and blind spots when driving or operating.

Be aware of boom position and tailswing when rotating turntable.

Check work area for overhead obstructions or other possible hazards.

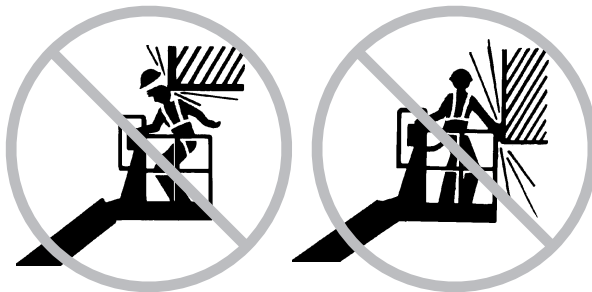

Be aware of crushing hazard when grasping the platform guard rail.

It is recommended that operators wear an approved hard hat when operating the machine.

Observe and use color-coded direction arrows on the platform controls and drive chassis for drive and steer functions.

Do not lower the boom unless the area below is clear of personnel and obstructions.

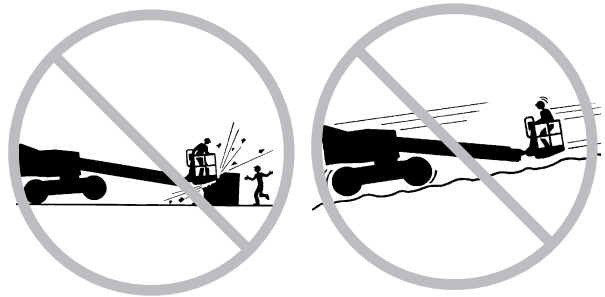

Limit travel speed according to condition of ground surface, congestion, slope, location of personnel and any other factors which may cause collision.

Do not operate a boom in the path of any crane unless the controls of the crane have been locked out and/or precautions have been taken to prevent any potential collision.

No stunt driving or horseplay while operating a machine.

Component Damage Hazards

Do not use any battery or charger greater than 12V to jump-start the engine.

Do not use machine as a ground for welding.

Be sure hydraulic shutoff valves (located by hydraulic tank) are open before starting engine.

SAFETY RULES

Explosion and Fire Hazards

Do not start engine if you smell or detect liquid petroleum gas (LPG), gasoline, diesel fuel or other explosive substances.

Do not refuel machine with engine running.

Refuel machine and charge battery only in an open, well-ventilated area away from sparks, flames and lighted tobacco.

Do not operate the machine in hazardous locations or locations where potentially flammable or explosive gases or particles may be present.

Damaged Machine Hazards

Do not use a damaged or malfunctioning machine.

Conduct a thorough pre-operation inspection of the machine and test all functions before each work shift. Immediately tag and remove from service a damaged or malfunctioning machine.

Be sure all maintenance has been performed as specified in this manual and the *Genie S-80 & Genie S-85 Service Manual*.

Be sure all decals are in place and legible.

Be sure that the operator's, the safety and the responsibilities manuals are complete, legible and in the storage container located on the platform.

Decal Legend

Genie product decals use symbols, color coding and signal words to identify the following:



Safety alert symbol—used to alert personnel to potential personal injury hazards. Obey all safety messages that follow this symbol to avoid possible injury or death.



Red—used to indicate the presence of an imminently hazardous situation which, if not avoided, will result in death or serious injury.



Orange—used to indicate the presence of a potentially hazardous situation which, if not avoided, could result in death or serious injury.



Yellow with safety alert symbol—used to indicate the presence of a potentially hazardous situation which, if not avoided, may cause minor or moderate injury.



Yellow without safety alert symbol—used to indicate the presence of a potentially hazardous situation which, if not avoided, may result in property damage.



Green—used to indicate operation or maintenance information.

Controls

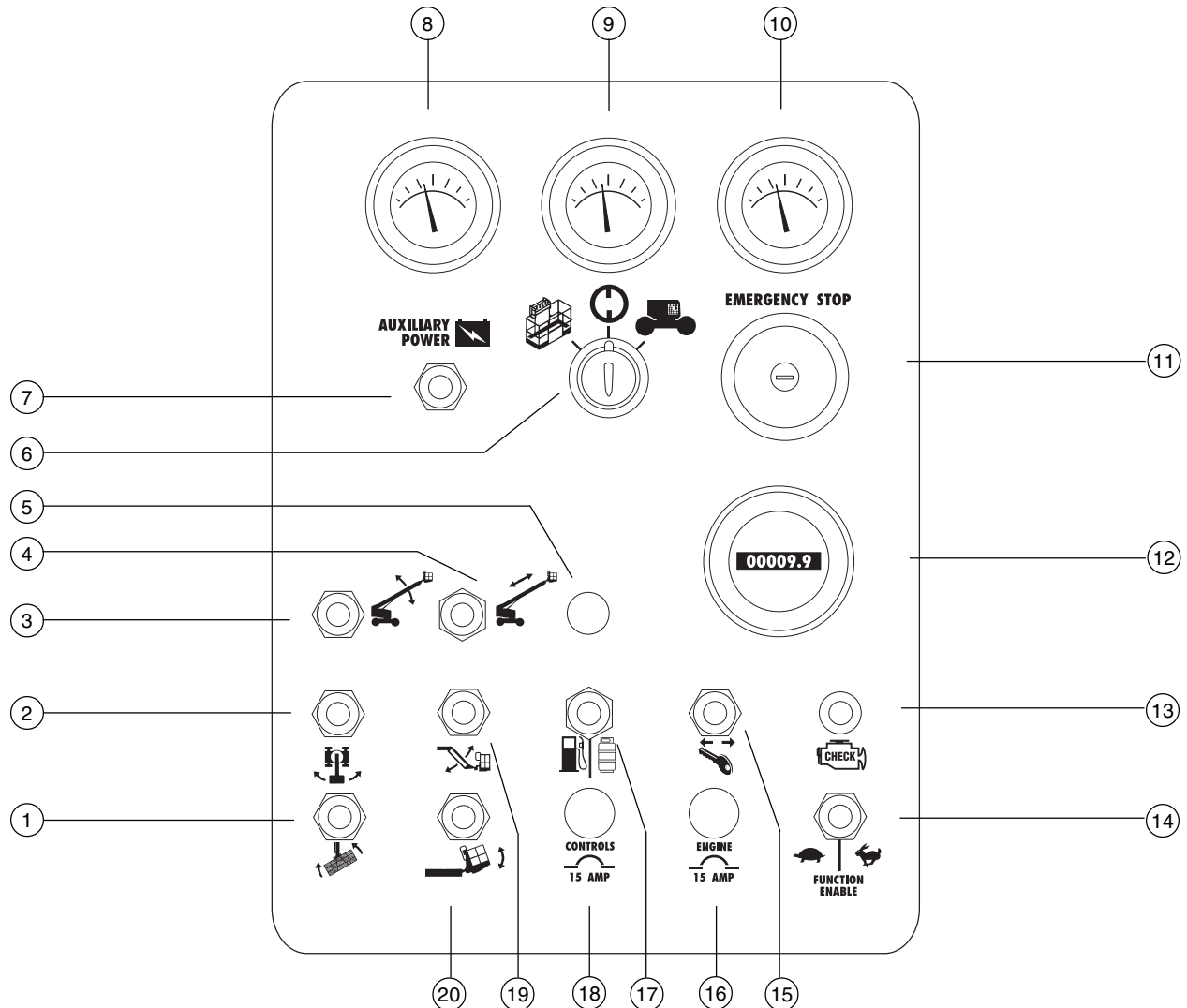

Ground Control Panel

- | | | | |
|----|---|----|--|
| 1 | Platform rotate switch | 11 | Emergency Stop button |
| 2 | Turntable rotate switch | 12 | Hour meter |
| 3 | Boom up/down switch | 13 | Gasoline/LPG models: Check engine light Deutz Diesel models: Glow plug switch (option) |
| 4 | Boom extend/retract switch | 14 | Function enable switch |
| 5 | not used | 15 | Engine start switch |
| 6 | Key switch for platform/off/ground selection | 16 | 15A breaker for engine electrical circuits |
| 7 | Auxiliary power switch | 17 | Gasoline/LPG select switch |
| 8 | Gasoline/LPG models: Water temperature gauge Deutz Diesel models: Oil temperature gauge | 18 | 15A breaker for control electrical circuits |
| 9 | Oil pressure gauge | 19 | S-85 only: Jib boom up/down switch |
| 10 | Voltage gauge | 20 | Platform level switch |

CONTROLS

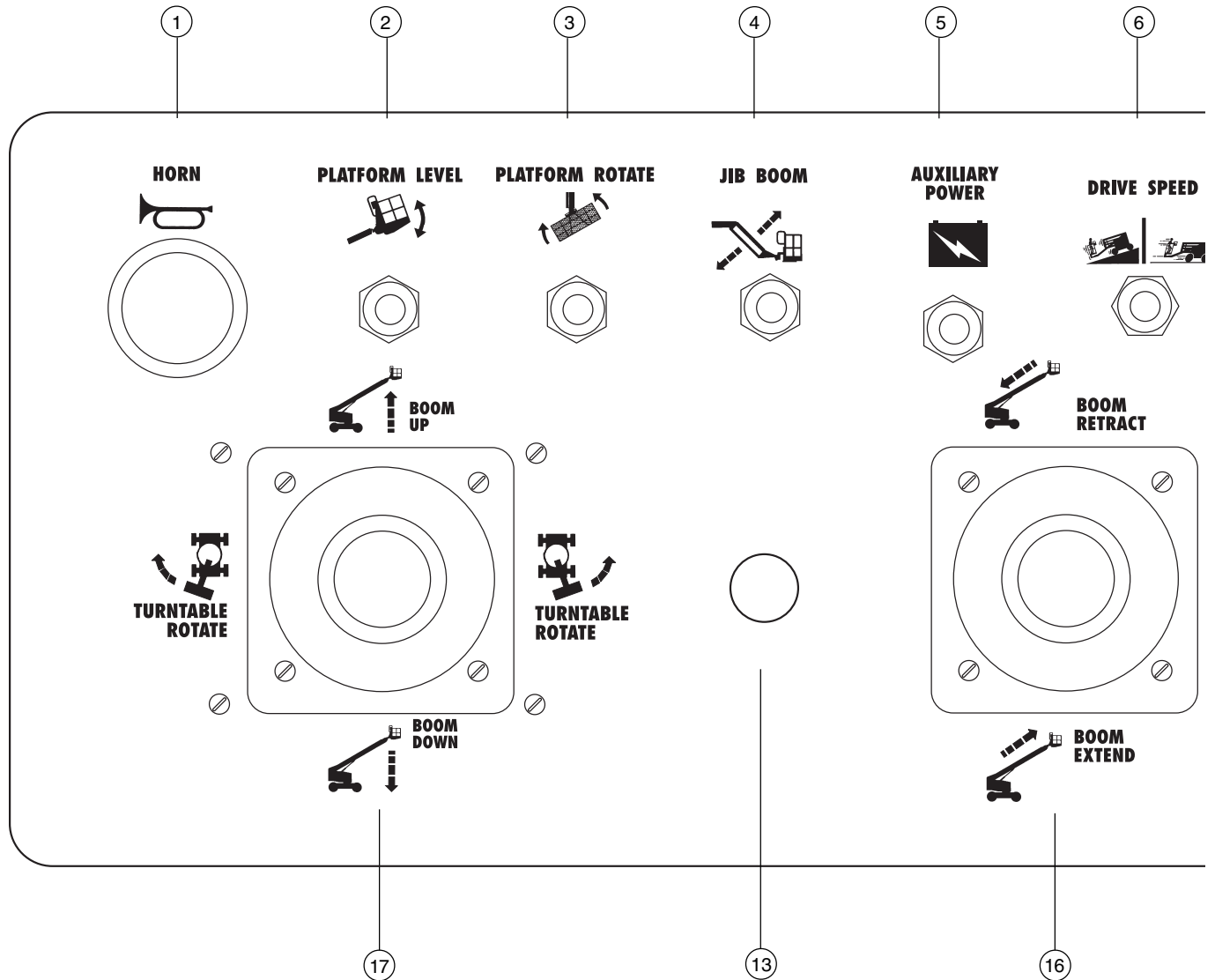

Platform Control Panel

- | | |
|---|--|
| <ul style="list-style-type: none"> 1 Service horn button 2 Platform level switch 3 Platform rotate switch 4 S-85 only: Jib boom up/down switch 5 Auxiliary power switch 6 Drive speed select switch | <ul style="list-style-type: none"> 7 Check engine light 8 Engine start switch 9 Engine idle (rpm) select switch <ul style="list-style-type: none"> · Rabbit & Foot Switch: foot switch activated high idle · Turtle: low idle · Rabbit: high idle |
|---|--|

CONTROLS

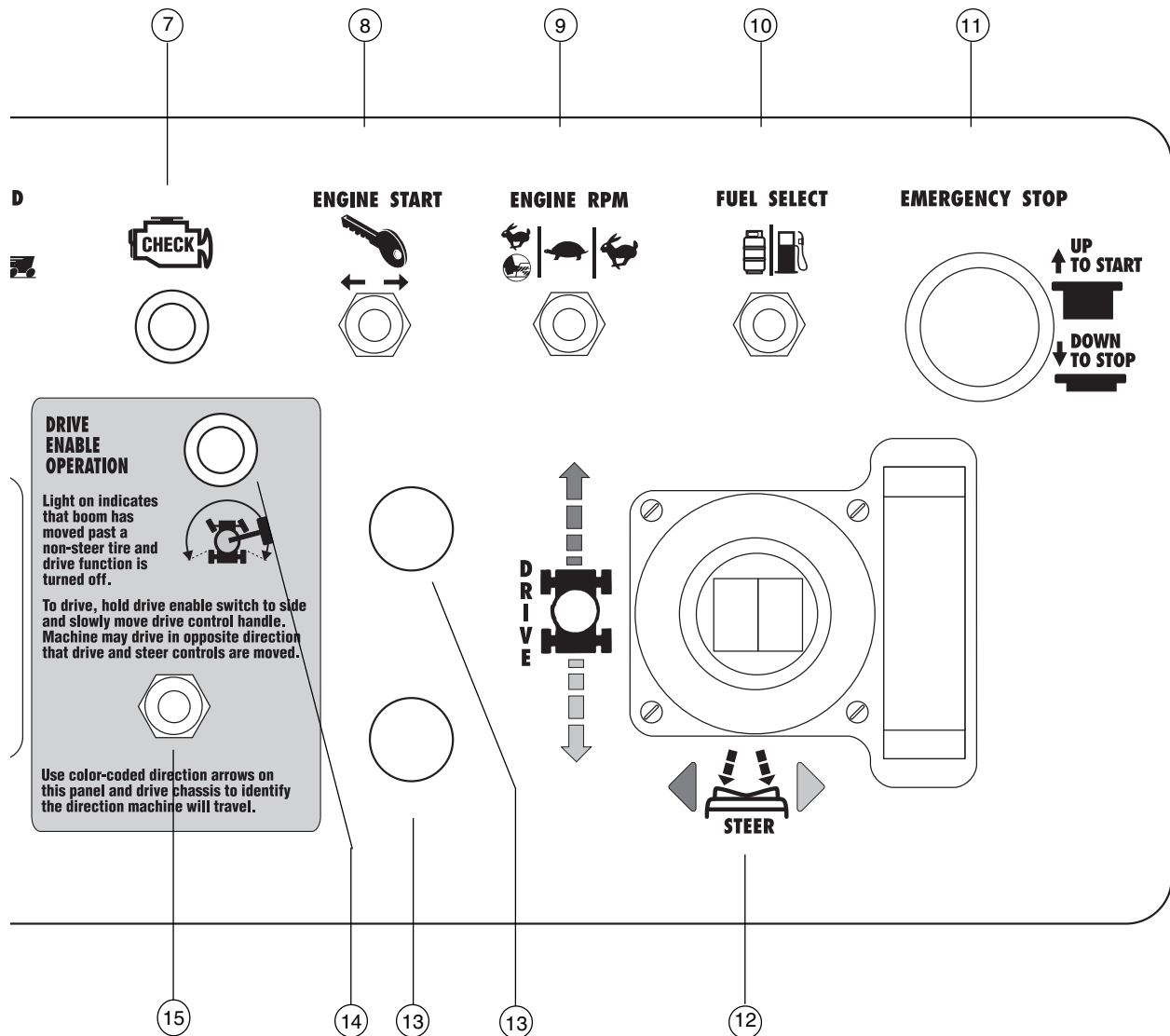

10 Gasoline/LPG models: Gasoline/LPG select switch
 Deutz Diesel models: Glow plug switch (option)

11 Emergency Stop button

12 Proportional control handle for drive function and thumb rocker for steer function

13 Optional equipment

14 Drive enable indicator light

15 Drive enable switch

16 Proportional control handle for boom extend/retract

17 Dual axis proportional control handle for boom up/down and turntable rotate left/right functions

Pre-operation Inspection



Do Not Operate Unless:

- You learn and practice the principles of safe machine operation contained in this operator's manual.

1 Avoid hazardous situations.

2 Always perform a pre-operation inspection.

Know and understand the above principles before going on to the next section.

3 Always perform function tests prior to use.

4 Inspect the work place.

5 Only use the machine as it was intended.

Fundamentals

It is the responsibility of the operator to perform a Pre-operation Inspection and routine maintenance.

The Pre-operation Inspection is a visual inspection performed by the operator prior to each work shift. The inspection is designed to discover if anything is apparently wrong with a machine before the operator performs the function tests.

The Pre-operation inspection also serves to determine if routine maintenance procedures are required. Only routine maintenance items specified in this manual may be performed by the operator.

Refer to the list on the next page and check each of the items and locations for modifications, damage or loose or missing parts.

A damaged or modified machine must never be used. If damage or any variation from factory delivered condition is discovered, the machine must be tagged and removed from service.

Repairs to the machine may only be made by a qualified service technician, according to the manufacturer's specifications. After repairs are completed, the operator must perform a pre-operation inspection again before going on to the function tests.

Scheduled maintenance inspections shall be performed by qualified service technicians, according to the manufacturer's specifications and the requirements listed in the responsibilities manual.

PRE-OPERATION INSPECTION

Pre-operation Inspection

- ❑ Be sure that the operator's, safety and responsibilities manuals are complete, legible and in the storage container located in the platform.
- ❑ Be sure that all decals are legible and in place. See Decals section.
- ❑ Check for engine oil leaks and proper oil level. Add oil if needed. See Maintenance section.
- ❑ Check for hydraulic oil leaks and proper oil level. Add oil if needed. See Maintenance section.
- ❑ Check for engine coolant leaks and proper level of coolant. Add coolant if needed. See Maintenance section.
- ❑ Check for battery fluid leaks and proper fluid level. Add distilled water if needed. See Maintenance section.
- ❑ Check for proper tire pressure. Add air if needed. See Maintenance section.

Check the following components or areas for damage and improperly installed, loose or missing parts:

- ❑ Electrical components, wiring and electrical cables
- ❑ Hydraulic hoses, fittings, cylinders and manifolds
- ❑ Fuel and hydraulic tanks
- ❑ Drive and turntable motors and drive hubs
- ❑ Boom wear pads
- ❑ Axle wear pads
- ❑ Tires and wheels
- ❑ Engine and related components

- ❑ Limit switches and horn
 - ❑ Alarms and beacons (if equipped)
 - ❑ Nuts, bolts and other fasteners
 - ❑ Platform entry mid-rail or gate
- Check entire machine for:
- ❑ Crack in welds or structural components
 - ❑ Dents or damage to machine
 - ❑ Be sure that all structural and other critical components are present and all associated fasteners and pins are in place and properly tightened.
 - ❑ After you complete your inspection, be sure that all compartment covers are in place and latched.

Maintenance



Observe and Obey:

- ☑ Only routine maintenance items specified in this manual shall be performed by the operator.
- ☑ Scheduled maintenance inspections shall be completed by qualified service technicians, according to the manufacturer's specifications and the requirements specified in the responsibilities manual.

Maintenance Symbols Legend

NOTICE

The following symbols have been used in this manual to help communicate the intent of the instructions. When one or more of the symbols appear at the beginning of a maintenance procedure, it conveys the meaning below.



Indicates that tools will be required to perform this procedure.



Indicates that new parts will be required to perform this procedure.



Indicates that a cold engine is required before performing this procedure.

Check the Engine Oil Level



Maintaining the proper engine oil level is essential to good engine performance and service life. Operating the machine with an improper oil level can damage engine components.

NOTICE

Check the oil level with the engine off.

- 1 Check the oil dipstick.

Gasoline/LPG Engine: located above the bellhousing on the bulkhead side of the engine.

Diesel Engine: located on the engine block near the engine oil filter.

- ⊙ Result: The oil level should be at the full mark on the dipstick. Add oil as needed.

Ford LRG-425 EFI Engine

Oil capacity (including filter) 4.5 quarts 4.3 liters

Oil viscosity requirements

| | |
|-----------------------------|--------|
| below 60°F / 15.5°C | 5W-30 |
| -10° to 90°F / -23° to 32°C | 5W-30 |
| above -10°F / -23°C | 5W-30 |
| above 25°F / -4°C | 10W-30 |

Use oils meeting API classification SH or SG grade. Units ship with 10-40 CC/SG.

MAINTENANCE

Deutz F4L 1011F Engine
Oil capacity (including filter) 8.5 quarts 8 liters

Oil viscosity requirements

| | |
|---------------------------------|--------|
| below 60°F / 15.5°C (synthetic) | 5W-30 |
| -10°F to 90°F / -23°C to 32°C | 10W-40 |
| above -4°F / -34°C | 15W-40 |

Engine oil should have properties of API classification CC/SE or CC/SF grades.
 Units ship with 10-40 CC/SG.

Perkins 704-30 Engine
Oil capacity (including filter) 9.6 quarts 9 liters

Oil viscosity requirements

| | |
|-------------------------------|--------|
| below 60°F / 15.5°C | 15W-40 |
| -10°F to 90°F / -23°C to 32°C | 10W-30 |
| above -4°F / -34°C | 15W-40 |

Engine oil should have properties of API classification CF4 grade.
 Units ship with 10-40 CC/SG.

Check the Hydraulic Oil Level



Maintaining the hydraulic oil at the proper level is essential to machine operation. Improper hydraulic oil levels can damage hydraulic components. Daily checks allow the inspector to identify changes in oil level that might indicate the presence of hydraulic system problems.

- 1 Be sure that the boom is in the stowed position, then visually inspect the sight gauge located on the side of the hydraulic oil tank. Add oil as needed.
- ⊙ Result: The hydraulic oil level should be within the top 2 inches (5 cm) of the sight gauge.

Hydraulic oil specifications

| Hydraulic oil type | Dexron equivalent |
|-----------------------------------|--------------------------|
| Tank capacity | 45 gallons 170 liters |
| Hydraulic system (including tank) | 55 gallons 208 liters |

MAINTENANCE

Check the Engine Coolant Level - Liquid Cooled Models



Maintaining the engine coolant at the proper level is essential to engine service life. Improper coolant level will affect the engine's cooling capability and damage engine components. Daily checks will allow the inspector to identify changes in coolant level that might indicate cooling system problems.

CAUTION Burn hazard. Beware of hot engine parts and coolant. Contact with hot engine parts and/or coolant may cause severe burns.

- 1 Check the fluid level in the coolant recovery tank. Add fluid as needed.
- ⊙ Result: The fluid level should be at the FULL mark.

NOTICE Do not remove the radiator cap.

Check the Batteries



Proper battery condition is essential to good engine performance and operational safety. Improper fluid levels or damaged cables and connections can result in engine component damage and hazardous conditions.

WARNING Electrocutation hazard. Contact with hot or live circuits may result in death or serious injury. Remove all rings, watches and other jewelry.

WARNING Bodily injury hazard. Batteries contain acid. Avoid spilling or contacting battery acid. Neutralize battery acid spills with baking soda and water.

- 1 Put on protective clothing and eye wear.
- 2 Be sure that the battery cable connections are free of corrosion.
- 3 Be sure that the battery hold downs and cable connections are tight.
- 4 Remove the battery vent caps.
- 5 Check the battery acid level. If needed, replenish with distilled water to the bottom of the battery fill tube. Do not overfill.
- 6 Install the vent caps.

NOTICE Adding terminal protectors and a corrosion preventative sealant will help eliminate corrosion on the battery terminals and cables.

MAINTENANCE

Check the Tire Pressure



NOTICE This procedure does not need to be performed on machines equipped with the foam-filled tire option.

AWARNING Bodily injury hazard. An over-inflated tire can explode and could cause death or serious injury.

AWARNING Tip-over hazard. Do not use temporary flat tire repair products.

To safeguard maximum stability, achieve optimum machine handling and minimize tire wear, it is essential to maintain proper pressure in all air-filled tires.

- 1 Check each tire with an air pressure gauge. Add air as needed.

Tire specifications

| | |
|-----------|---------------------|
| Tire size | 15-22.5SAT |
| Pressure | 100 psi 6.89 bar |

Scheduled Maintenance

The scheduled maintenance items must be completed by a person trained and qualified to perform maintenance on this machine according to the procedures found in the service manual for this machine.

Inspections and maintenance described below require the qualified entity to record and retain records of all inspections and maintenance items for four years.

Machines that have been out of service for more than three months must receive the quarterly inspection before placing the machine back into service.

The Schedule

There are five types of maintenance inspections that must be performed according to a schedule—daily, quarterly, six months, annual, two year. To account for repeated procedures, the *Scheduled Maintenance Procedures Section and the Maintenance Inspection Report* have been divided into five subsections—A, B, C, D and E. Use the following chart to determine which group(s) of procedures are required to perform a scheduled inspection.

| Inspection | Table or Checklist |
|-------------------------------|--------------------|
| Daily or every 8 hours | A |
| Quarterly or every 250 hours | A + B |
| Six months or every 500 hours | A + B + C |
| Annual or every 1000 hours | A + B + C + D |
| Two year or every 2000 hours | A + B + C + D + E |

Maintenance Inspection Report

The maintenance inspection report contains checklists for each type of scheduled inspection.

Make copies of the *Maintenance Inspection Report* to use for each inspection. Store completed forms for three years.

Function Tests



Do Not Operate Unless:

- ☑ You learn and practice the principles of safe machine operation contained in this operator's manual.

- 1 Avoid hazardous situations.
- 2 Always perform a pre-operation inspection.

3 Always perform function tests prior to use.

Know and understand the above principles before going on to the next section.

- 4 Inspect the work place.
- 5 Only use the machine as it was intended.

Fundamentals

The Function Tests are designed to discover any malfunctions before the machine is put into service. The operator must follow the step-by-step instructions to test all machine functions.

A malfunctioning machine must never be used. If malfunctions are discovered, the machine must be tagged and removed from service. Repairs to the machine may only be made by a qualified service technician, according to the manufacturer's specifications.

After repairs are completed, the operator must perform a pre-operation inspection and function tests again before putting the machine into service.

- 1 Select a test area that is firm, level and free of obstruction.

At the Ground Controls

- 2 Turn the key switch to ground control.
- 3 Pull out the red Emergency Stop button to the ON position.
- ⊙ Result: Beacon (if equipped) should flash.
- 4 Start the engine (see *Starting The Engine*, page 17).

Test Emergency Stop

- 5 Push in the red Emergency Stop button to the OFF position.
- ⊙ Result: Engine should turn off and all functions should not operate.
- 6 Pull out the red Emergency Stop button to the ON position and restart the engine.

Test the Extendable Axles

- 7 Hold the function enable switch to either side and activate the boom raise function.
- ⊙ Result: The boom should raise to horizontal and then stop. The boom should not raise above the limit switch unless both axles are extended.
- 8 Hold the function enable switch to either side and activate the boom lower function.
- ⊙ Result: The boom should lower and return to the stowed position.

FUNCTION TESTS

- 9 Hold the function enable switch to either side and activate the boom extend function.
- ⊙ Result: The boom should extend no more than 6 inches (15 cm) and then stop. The boom should not extend beyond the limit switch unless both axles are extended.
- 10 Hold the function enable switch to either side and activate the boom retract function.
- ⊙ Result: The boom should retract.
- 11 At the extendable axle controls, extend the jack.
- ⊙ Result: The jack should extend and raise the machine.
- 12 Extend the axle.
- ⊙ Result: The axle should extend.
- 13 Retract the jack.
- ⊙ Result: The jack should retract and lower the machine.
- 14 Repeat steps 11-13 for the other jack and axle.
- 15 Hold the function enable switch to either side and activate the boom raise and lower function.
- ⊙ Result: The boom should raise and lower normally.
- 16 Hold the function enable switch to either side and activate the boom extend and retract functions.
- ⊙ Result: The boom should extend and retract normally.

Test the Machine Functions

- 17 Do not hold the function enable switch to either side. Attempt to activate each boom and platform function toggle switch.
- ⊙ Result: All boom and platform functions should **not** operate.
- 18 Hold the function enable switch to either side and activate each boom and platform function toggle switch.
- ⊙ Result: All boom and platform functions should operate through a full cycle. Descent alarm (if equipped) should sound while boom is lowering.

Machines equipped with Platform Level Control Disable Function: The platform level toggle switch will not operate when the boom is raised or extended past the drive speed limit switches.

Test the Tilt Sensor

- 19 Pull out the platform red Emergency Stop button to the ON position. Turn the key switch to platform control.
- 20 Open the tank side turntable cover and locate the tilt sensor next to the control box.
- 21 Press down one side of the tilt sensor.
- ⊙ Result: The alarm, located in the platform, should sound.

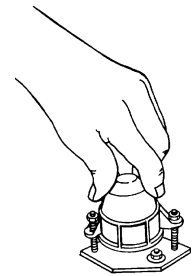

FUNCTION TESTS

Test Auxiliary Controls

- 22 Turn the key switch to ground control and shut the engine off.
- 23 Pull out the red Emergency Stop button to the ON position.
- 24 Simultaneously hold the auxiliary power switch on and activate each boom function toggle switch.

Note: To conserve battery power, test each function through a partial cycle.

- ⊙ Result: All boom functions should operate.

At the Platform Controls**Test Emergency Stop**

- 25 Turn the key switch to platform control and restart the engine.
 - 26 Push in the platform red Emergency Stop button to the OFF position.
- ⊙ Result: The engine should turn off and all functions should not operate.
- 27 Pull out the red Emergency Stop button and restart the engine.

Test the Hydraulic Oil Return Filter

- 28 Move the engine idle select switch to high idle (rabbit symbol).
- 29 Locate and check the hydraulic filter condition indicator.

- ⊙ Result: The filter should be operating with the plunger in the green area.

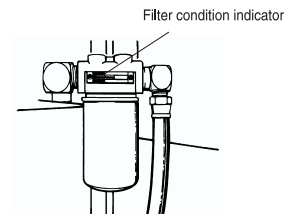

- 30 Move the engine idle select switch to foot switch activated high idle (rabbit and foot switch symbol).

Test the Service Horn

- 31 Push the horn button.
- ⊙ Result: The service horn should sound.

Test the Foot Switch

- 32 Push in the platform Emergency Stop button to the OFF position.
 - 33 Pull out the Emergency Stop button to the ON position but do not start the engine.
 - 34 Press down the foot switch and attempt to start engine by moving the start toggle switch to either side.
- ⊙ Result: The engine should **not** start.
- 35 Do not press down the foot switch and restart engine.
 - 36 Move the lift/drive select switch to the lift position (if equipped).
 - 37 Do not press down the foot switch. Then test each machine function.
- ⊙ Result: The machine functions should **not** operate.

FUNCTION TESTS

Test Machine Functions

- 38 Move the lift/drive select switch to the lift position (if equipped).
- 39 Press down the foot switch.
- 40 Activate each machine function control handle or toggle switch.
- ⊙ Result: All boom/platform functions should operate through a full cycle.

Machines equipped with Platform Level Control Disable Function: The platform level toggle switch will not operate when the boom is raised or extended past the drive speed limit switches.

Test the Steering

- 41 Move the lift/drive select switch to the drive position (if equipped).
- 42 Press down the foot switch.
- 43 Depress the thumb rocker switch on top of the drive control handle in the direction identified by the blue triangle on the control panel.
- ⊙ Result: The steer wheels should turn in the direction that the blue triangles point on the drive chassis.
- 44 Depress the thumb rocker switch in the direction identified by the yellow triangle on the control panel.
- ⊙ Result: Steer wheels should turn in the direction that the yellow triangles point on the drive chassis.

Test Drive and Braking

- 45 Move the lift/drive select switch to the drive position (if equipped).
- 46 Press down the foot switch.
- 47 Slowly move the drive control handle in the direction indicated by the blue arrow on the control panel until the machine begins to move, then return the handle to the center position.
- ⊙ Result: The machine should move in the direction that the blue arrow points on the drive chassis, then come to an abrupt stop.
- 48 Slowly move the drive control handle in the direction indicated by the yellow arrow on the control panel until the machine begins to move, then return the handle to the center position.
- ⊙ Result: The machine should move in the direction that the yellow arrow points on the drive chassis, then come to an abrupt stop.

Note: The drive brakes must be able to hold the machine on any slope it is able to climb.

FUNCTION TESTS

Test the Drive Enable System

- 49 Move the lift/drive select switch to the lift position (if equipped).
- 50 Press down the foot switch. Then lower the boom to the stowed position.

51

- ⦿ Result: The drive enable indicator light should come on and remain on while the boom is anywhere in the range shown.



- 52 Move the lift/drive select switch to the drive position (if equipped).

- 53 Move the drive control handle off center.

- ⦿ Result: The drive function should **not** operate.

- 54 Move and hold the drive enable toggle switch to either side and slowly move the drive control handle off center.

- ⦿ Result: The drive function should operate.

Note: When the drive enable system is in use, the machine may drive in the opposite direction that the drive and steer control handle is moved.

Use the color-coded direction arrows on the platform controls and the drive chassis to identify the direction of travel.

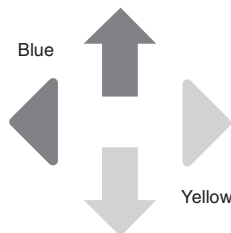
**Test Limited Drive Speed**

- 55 Move the lift/drive select switch to the lift position (if equipped).

- 56 Press down the foot switch.

- 57 Raise the boom to just above horizontal.

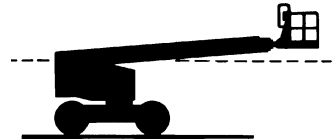

- 58 Move the lift/drive select switch to the drive position (if equipped).

- 59 Slowly move the drive control handle to the full drive position.

- ⦿ Result: The maximum achievable drive speed with the boom raised should not exceed 1 foot per second (0.3 meters per second).

- 60 Move the lift/drive select switch to the lift position (if equipped).

- 61 Lower the boom to the stowed position.

- 62 Extend the boom 1 foot (30 cm).

- 63 Move the lift/drive select switch to the drive position (if equipped).

- 64 Slowly move the drive control handle to the full drive position.

- ⦿ Result: The maximum achievable drive speed with the boom extended should not exceed 1 foot per second (0.3 meters per second).

If the drive speed with the boom raised or extended exceeds 1 foot per second (0.3 meters per second), immediately tag and remove the machine from service.

FUNCTION TESTS

Test Auxiliary Controls

- 65 Shut off the engine.
- 66 Pull out the red Emergency Stop button to the ON position.
- 67 Move the lift/drive select switch to the lift position (if equipped).
- 68 Press down the foot switch.
- 69 Simultaneously hold auxiliary power switch on and activate each function control handle or toggle switch.

Note: To conserve battery power, test each function through a partial cycle.

- ⦿ Result: All boom and steer functions should operate. Drive functions should not operate with auxiliary power.

Test the Lift/Drive Select Switch (if equipped)

- 70 Move the lift/drive select switch to the lift position.
- 71 Press down the foot switch.
- 72 Move the drive control handle off center.
 - ⦿ Result: No drive functions should operate.
- 73 Activate each boom function toggle switch.
 - ⦿ Result: All boom functions should operate.
- 74 Move the lift/drive select switch to the drive position.
- 75 Press down the foot switch.
- 76 Activate each boom function toggle switch.
 - ⦿ Result: No boom functions should operate.
- 77 Move the drive control handle off center.
 - ⦿ Result: The drive functions should operate.

Work Place Inspection



Do Not Operate Unless:

- You learn and practice the principles of safe machine operation contained in this operator's manual.

- 1 Avoid hazardous situations.
- 2 Always perform a pre-operation inspection.
- 3 Always perform function tests prior to use.

4 Inspect the work place.

Know and understand the above principles before going on to the next section.

- 5 Only use the machine as it was intended.

Work Place Inspection

Be aware of and avoid the following hazardous situations:

- drop-offs or holes
- bumps, floor obstructions or debris
- overhead obstructions and high voltage conductors
- hazardous locations
- inadequate surface support to withstand all load forces imposed by the machine
- wind and weather conditions
- the presence of unauthorized personnel
- other possible unsafe conditions

Fundamentals

The Work Place Inspection helps the operator determine if the work place is suitable for safe machine operation. It should be performed by the operator prior to moving the machine to the work place.

It is the operator's responsibility to read and remember the work place hazards, then watch for and avoid them while moving, setting up and operating the machine.

Operating Instructions



Do Not Operate Unless:

- You learn and practice the principles of safe machine operation contained in this operator's manual.
 - 1 Avoid hazardous situations.
 - 2 Always perform a pre-operation inspection.
 - 3 Always perform function tests prior to use.
 - 4 Inspect the work place.
 - 5 Only use the machine as it was intended.**

Fundamentals

The Operating Instructions section provides instructions for each aspect of machine operation. It is the operator's responsibility to follow all the safety rules and instructions in the operator's, safety and responsibilities manuals.

Using the machine for anything other than lifting personnel and tools to an aerial work site is unsafe and dangerous.

Only trained and authorized personnel should be permitted to operate a machine. If more than one operator is expected to use a machine at different times in the same work shift, they must all be qualified operators and are all expected to follow all safety rules and instructions in the operator's, safety and responsibilities manuals. That means every new operator should perform a pre-operation inspection, function tests, and a work place inspection before using the machine.

Starting the Engine

- 1 At the ground controls, turn the key switch to the desired position.
- 2 Be sure both ground and platform control red Emergency Stop buttons are pulled out to the ON position.
- 3 Gasoline/LPG models: Choose fuel by moving the fuel select switch to the desired position.
- 4 Move the engine start toggle switch to either side. If engine fails to start or dies, the restart delay will disable the start switch for 3 seconds.



If engine fails to start after 15 seconds of cranking, determine cause and repair any malfunction. Wait 60 seconds before trying to start again.

All models: In extreme cold conditions, 20°F (-6°C) and below, warm engine for 5 minutes to prevent hydraulic system damage.

Gasoline/LPG models: In extreme cold conditions, 20°F (-6°C) and below, machine should be started on gasoline, then switched to LPG.

Emergency Stop

Push in either ground or platform red Emergency Stop button to the OFF position to stop all functions and turn engine off.

Repair any function that operates when the Emergency Stop button is pushed in.

Selecting and operating the ground controls will override the platform Emergency Stop button.

OPERATING INSTRUCTIONS

Auxiliary Controls

Use auxiliary power if the primary power source (engine) fails.

- 1 Turn the key switch to ground or platform control.
- 2 Pull out the red Emergency Stop button to the ON position.
- 3 Move the lift/drive select switch to the lift position (if equipped) when operating the auxiliary controls from the platform.
- 4 Press down the foot switch when operating the auxiliary controls from the platform.
- 5 Simultaneously hold auxiliary power switch ON and activate desired function.

The drive function will not operate with auxiliary power.

Extendable Axles

Be sure the machine is on a firm, level surface. Use shoring material under the jack foot pad as required.

- 1 Push and hold the jack control handle to extend the jack. Do not release handle.
- 2 Push the axle control handle to extend the axle. Pull the axle control handle to retract the axle.
- 3 Release the handles when the axle is fully extended or retracted.
- 4 Pull the jack control handle to retract the jack.
- 5 Repeat for other axle.

Operation from Ground

- 1 Turn the key switch to ground control.
- 2 Pull out the red Emergency Stop button to the ON position.
- 3 Gasoline/LPG models: Choose fuel by moving fuel select switch to desired position.
- 4 Start the engine.

To Position Platform

- 1 Extend the axles.
- 2 Hold the function enable switch to either side.
- 3 Move the appropriate toggle switch according to markings on the control panel.

Drive and steer functions are not available from the ground controls.

Machines equipped with Platform Level Control Disable Function: The platform level toggle switch will not operate when the boom is raised or extended past the drive speed limit switches.

OPERATING INSTRUCTIONS

Operation from Platform

- 1 Turn the key switch to platform control.
- 2 Pull out both ground and platform red Emergency Stop buttons to the ON position.
- 3 Gasoline/LPG models: Choose fuel by moving fuel select switch to desired position.
- 4 Start engine. Do not press down the foot switch when starting engine.

To Position Platform

- 1 Extend the axles.
- 2 Move the lift/drive select switch to the lift position (if equipped).
- 3 Press down the foot switch.
- 4 Slowly move the appropriate function control handle or toggle switch according to the markings on the control panel.

Machines equipped with Platform Level Control Disable Function: The platform level toggle switch will not operate when the boom is raised or extended past the drive speed limit switches.

To Steer

- 1 Move the lift/drive select switch to the drive position (if equipped).
- 2 Press down the foot switch.
- 3 Turn the steering wheels with the thumb rocker switch located on top of the drive control handle.

Use the color-coded direction arrows on the platform controls and the drive chassis to identify the direction wheels will turn.

To Drive

- 1 Move the lift/drive select switch to the drive position (if equipped).
- 2 Press down the foot switch.
- 3 Increase speed: Slowly move the drive control handle off center.
Decrease speed: Slowly move the drive control handle toward center.
Stop: Return the drive control handle to center or release the foot switch.

Use the color-coded direction arrows on the platform controls and the drive chassis to identify the direction machine will travel.

Machine travel speed is restricted when the boom is raised or extended.

Drive Enable

Light ON indicates that the boom has moved just past either non-steering wheel and drive function has been interrupted.

To drive, hold the drive enable switch to either side and slowly move the drive control handle off center.

Be aware that the machine may move in the opposite direction that the drive and steer controls are moved.

Always use the color-coded direction arrows on the platform controls and the drive chassis to identify the direction machine will travel.

OPERATING INSTRUCTIONS

Generator

To operate generator, move the generator toggle switch to the generator position. The engine will continue to run but no drive or platform functions will operate.

Plug power tool into the power to platform GFCI outlet.

To resume machine functions, move generator toggle switch to machine functions position. All functions will operate.

Engine Idle Select (rpm)

Select engine idle (rpm) using the symbols on the control panel.

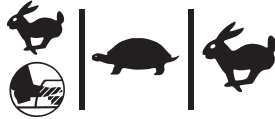

- Rabbit and foot switch symbol: foot switch activated high idle
- Turtle symbol: low idle
- Rabbit symbol: high idle

Check Engine Light (if equipped)

Light on and engine stopped: Tag the machine and remove from service.

Light on and engine still running: Contact service personnel within 24 hours.

Stopping the Engine

Push in the red Emergency Stop button and turn the key switch to the OFF position.

After Each Use

- 1 Select a safe parking location—firm level surface, clear of obstruction and traffic.
- 2 Retract and lower the boom to the stowed position.
- 3 Rotate the turntable so that the boom is between the non-steering wheels.
- 4 Turn the key switch to the OFF position and remove the key to secure from unauthorized use.
- 5 Chock the wheels.

Transport Instructions



Observe and Obey:

- ☑ Transport vehicle must be parked on a level surface.
- ☑ Transport vehicle must be secured to prevent rolling while machine is being loaded.
- ☑ Be sure vehicle capacity, loading surfaces and straps or lines are sufficient to withstand machine weight. See Specifications section.

Securing to Truck or Trailer for Transit

Always use the turntable rotation lock pin each time the machine is transported.

Always chock machine wheels in preparation for transport.

Use tie points on drive chassis for anchoring down to transport surface.

Use lower platform mount between boom end and platform to secure boom from side-to-side movement. Do not use excessive downward force when securing boom section.

Use chains or straps of ample load capacity. Turn key switch to the OFF position and remove key before transporting. Inspect entire machine for loose or unsecured items.

Free-wheel Configuration for Winching

Chock wheels to prevent machine from rolling. 2WD models: Release non-steer wheel brakes by turning over torque hub disconnect caps (see below).

4WD models: Release wheel brakes by turning over all four torque hub disconnect caps (see below).

Be sure winch line is properly secured to drive chassis tie points and path is clear of all obstructions.

Reverse procedures described to re-engage brakes.

Note: The pump free-wheel valve should always remain closed.

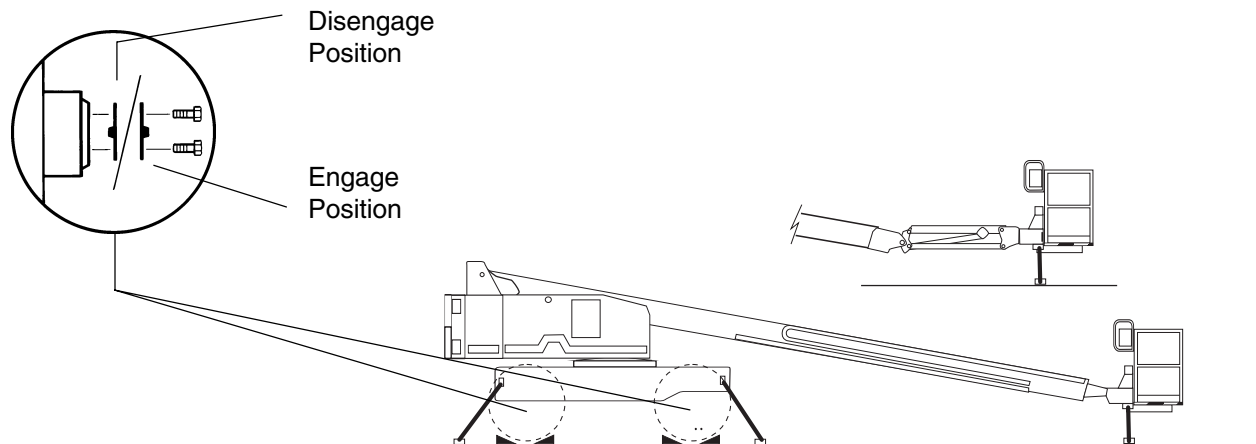

Decals

Decal Inspection

Use the pictures on the next page to verify that all decals are legible and in place.

Below is a numerical list with quantities and descriptions.

| Part No. | Decal Description | Quantity |
|----------|---------------------------------------|----------|
| 25994 | Caution - Component Damage Hazard | 1 |
| 27204 | Arrow - Blue | 1 |
| 27205 | Arrow - Yellow | 1 |
| 27206 | Triangle- Blue | 2 |
| 27207 | Triangle - Yellow | 2 |
| 27564 | Danger - Electrocutation Hazard | 3 |
| 28157 | Label - Dexron | 1 |
| 28158 | Label - Unleaded | 2 |
| 28159 | Label - Diesel | 2 |
| 28160 | Label - Liquid Petroleum Gas | 1 |
| 28161 | Danger - Crushing Hazard | 4 |
| 28163 | Notice - Maximum Side Force - 150 lbs | 1 |
| 28164 | Notice - Hazardous Materials | 1 |
| 28165 | Notice - Foot Switch | 1 |
| 28171 | Label - No Smoking | 2 |
| 28174 | Label - Power to Platform, 230V | 2 |
| 28175 | Caution - Compartment Access | 1 |
| 28176 | Notice - Missing Manuals | 1 |
| 28177 | Warning - Platform Rotate | 2 |
| 28181 | Warning - No Step or Ride | 1 |
| 28235 | Label - Power to Platform, 115V | 2 |
| 28236 | Warning - Failure To Read . . . | 1 |
| 30080* | Notice - Maximum Load 500 lbs | 1 |
| 31060 | Danger - Tip-over Hazard, Interlock | 1 |
| 32700 | Danger - Safety Rules | 2 |
| 32726 | Label - Glow Plug (option) | 1 |
| 32728 | Label - Generator (option) | 1 |
| 32932 | Danger - Tip Over- Axles | 2 |

| Part No. | Decal Description | Quantity |
|----------|--|----------|
| 32933 | Serial Plate - S-80 | 1 |
| 32996 | Notice - Axle Extension Operation | 2 |
| 32997 | Warning - Hand and Foot | 4 |
| 32998* | Notice - Maximum Load 600 lbs | 1 |
| 32999 | Notice - Tire Pressure | 2 |
| 33463 | Serial Plate - S-85 | 1 |
| 33550 | Safety Tape | — |
| 33952 | Danger - Tilt-Alarm | 1 |
| 33956 | Notice - Ford Engine Specs-Ford LRG | 1 |
| 33986 | Notice - Deutz Diesel Engine Specs | 1 |
| 35599 | Notice - Align Air Hoses | 1 |
| 40434 | Label - Lanyard Anchorage | 4 |
| 43594* | Notice - Maximum Load 750 lbs | 1 |
| 43595 | Danger - Tip-over, Tires | 1 |
| 43649 | Ground Control Panel | 1 |
| 43647 | Notice - Operating Instructions | 2 |
| 43663 | Notice - Function Enable | 1 |
| 49741 | Notice - Ford Engine Specs-LRG-425 EFI | 1 |
| 44769 | Lift/Drive Select (option) | 1 |
| 44981 | Airline to Platform | 2 |
| 44986 | Notice - Maximum Manual Force - 90 lbs | 1 |
| 49926 | Ground Control Panel | 1 |
| 52156 | Platform Control Panel | 1 |
| 52966 | Cosmetic - 4 x 2 | 1 |
| 52967 | Cosmetic - 4 x 4 | 1 |
| 52972 | CE Mark | 1 |
| 62920 | Cosmetic - Genie S-80 | 1 |
| 62921 | Cosmetic - S-80 | 2 |
| 62922 | Cosmetic - Genie S-85 | 1 |
| 62923 | Cosmetic - S-85 | 2 |
| 72160 | Ground Control Panel | 1 |
| 72162 | Platform Control Panel | 1 |

*Please reference the Specifications section or the chart on page 2 to determine the capacity of your machine.

DECALS

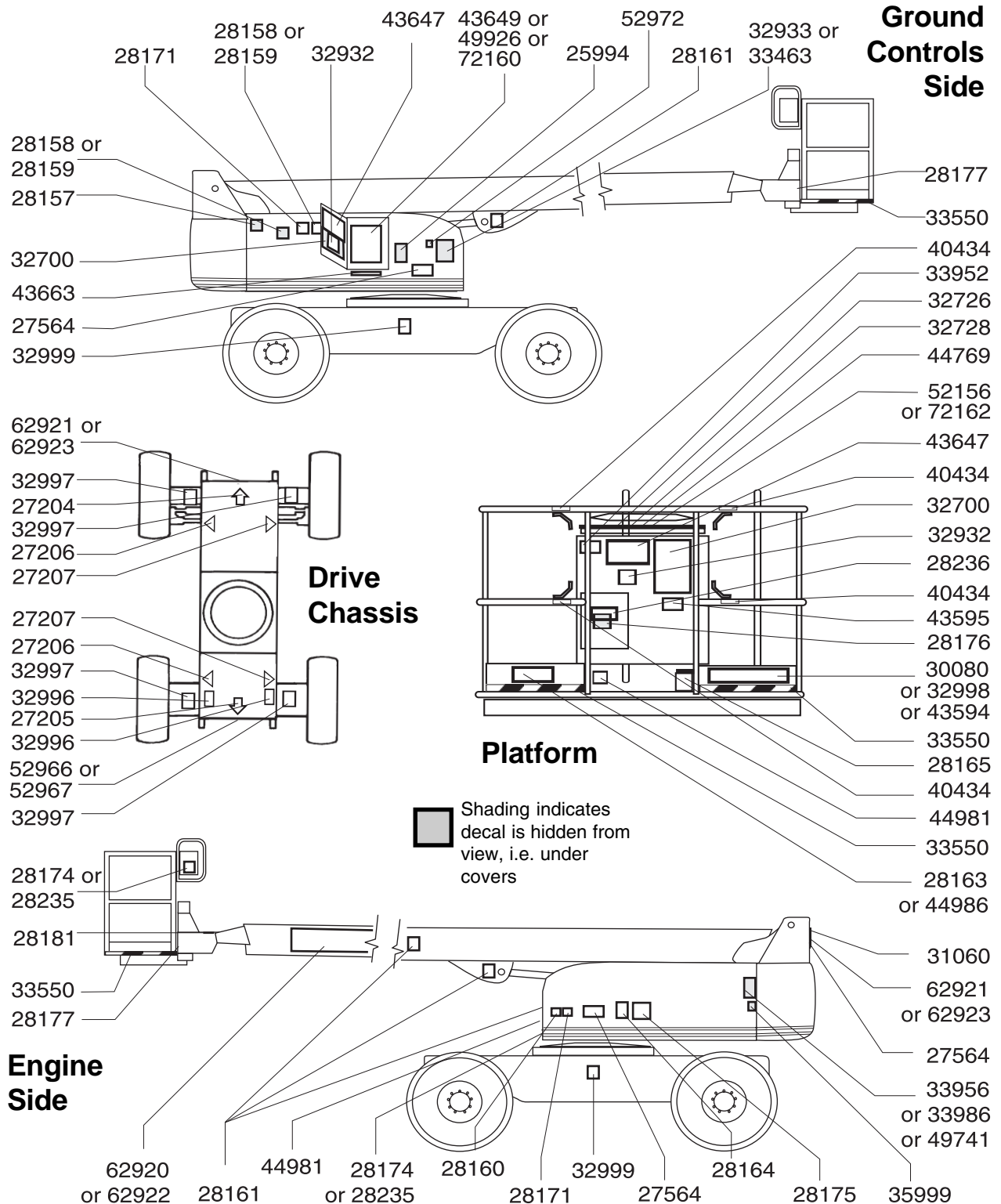

Specifications

| Model | S-80 | S-85 |
|--|--|---|
| Height, working maximum | 86 ft 26.2 m | 91 ft 27.7 m |
| Height, platform maximum | 80 ft 24.4 m | 85 ft 25.9 m |
| Height, stowed maximum | 9 ft 2 in 2.79 m | 9 ft 2 in 2.79 m |
| Horizontal reach maximum | 71 ft 11 in 21.9 m | 76 ft 11 in 23.4 m |
| Width | 7 ft 11 ¹ / ₂ in 2.43 m | 7 ft 11 ¹ / ₂ in 2.43 m |
| Length, stowed | 36 ft 8 in 11.2 m | 40 ft 7 in 12.4 m |
| Maximum load capacity 6 foot platform | 600 lb 272 kg | 500 lb 227 kg |
| Maximum load capacity 8 foot platform | 500 lb 227 kg | 500 lb 227 kg |
| Maximum load capacity 6 foot platform with foam-filled tires and proper counterweight configuration | 750 lb 340 kg | N/A N/A |
| Wheelbase | 9 ft 0 in 2.7 m | 9 ft 0 in 2.7 m |
| Turning radius (outside) | 23 ft 1 in 7.0 m | 23 ft 1 in 7.0 m |
| Turning radius (inside) | 10 ft 7 ¹ / ₂ in 3.2 m | 10 ft 7 ¹ / ₂ in 3.2 m |
| Turntable rotation (degrees) | | continuous |
| Turntable tailswing | 3 ft 8 ¹ / ₂ in 113.0 cm | 3 ft 8 ¹ / ₂ in 113.0 cm |
| Power source (choice) | Ford 63 Hp Gasoline/LPG LRG-423 or LRG-425 EFI Deutz 56 Hp Diesel F4L 1011 | |
| Drive speeds | 2WD | 4WD |
| Drive speed, stowed Gasoline/LPG models | 3.8 mph 6.1 km/h | 3.1 mph 4.9 km/h |
| | 40 ft/7.2 sec 12.2 m/7.2 sec | 40 ft/8.8 sec 12.2 m/8.8 sec |
| Drive speed, stowed Deutz Diesel models | 3.3 mph 5.3 km/h | 3 mph 4.8 km/h |
| | 40 ft/8.3 sec 12.2 m/8.3 sec | 40 ft/9.1 sec 12.2 m/9.1 sec |
| Drive speed, raised or extended - all models | 0.68 mph 1.1 km/h | 0.68 mph 1.1 km/h |
| | 40 ft/40 sec 12.2 m/40 sec | 40 ft/40 sec 12.2 m/40 sec |

| Model | S-80 | S-85 |
|--|--------------------------------|--------------------------------|
| Controls | 12V DC proportional | |
| Platform dimensions, 6 foot (length x width) | 72 in x 30 in 1.8 m x 76 cm | 72 in x 30 in 1.8 m x 76 cm |
| Platform dimensions, 8 foot (length x width) | 96 in x 36 in 2.4 m x 91 cm | 96 in x 36 in 2.4 m x 91 cm |
| Platform leveling | self-leveling | self-leveling |
| Platform rotation | 160° | 160° |
| AC outlet in platform | standard | standard |
| Hydraulic pressure (maximum) (boom functions) | 3000 psi 207 bar | 3000 psi 207 bar |
| Tire size | 15-22.5 SAT | 15-22.5 SAT |
| Gradeability, stowed (2WD/4WD) | | 30% / 38 % |
| Ground clearance | 11 in 28 cm | 11 in 28 cm |
| Hydraulic tank capacity | 45 gallons 170 liters | 45 gallons 170 liters |
| Fuel tank capacity | 30 gallons 114 liters | 30 gallons 114 liters |
| Weight | 33,380 lbs 15,141 kg | 35,860 lbs 16,266 kg |

Airborne noise emissions 80 dB
Maximum sound level at normal operating workstations (A-weighted)

Continuous improvement of our products is a Genie policy. Product specifications are subject to change without notice or obligation.

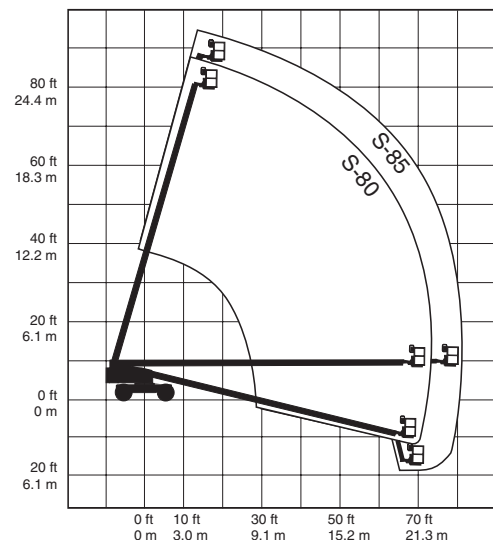

California Proposition 65

WARNING

The exhaust from this product contains chemicals known to the State of California to cause cancer, birth defects or other reproductive harm.

Genie Holland

Phone +31 70 51 78836
Fax +31 70 51 13993

Genie Scandinavia

Phone +46 31 3409612
Fax +46 31 3409613

Genie France

Phone +33 (0)2 37 26 09 99
Fax +33 (0)2 37 26 09 98

Genie Ibérica

Phone +34 93 579 5042
Fax +34 93 579 5059

Genie Germany

Phone +49 (0)4202 88520
Fax +49 (0)4202 8852-20

Genie U.K.

Phone +44 (0)1476 584333
Fax +44 (0)1476 584334

Genie Mexico City

Phone +52 5 653 03 84
Fax +52 5 664 40 16

Genie North America

Phone 425.881.1800
Toll Free USA and Canada
800.536.1800
Fax 425.883.3475

Genie Australia Pty Ltd.

Phone +61 7 3375 1660
Fax +61 7 3375 1002

Genie China

Phone +86 21 53852570
Fax +86 21 53852569

Genie Malaysia

Phone +60 4 228 1235
Fax +60 4 226 6872

Genie Japan

Phone +81 3 3453 6082
Fax +81 3 3453 6083

Genie Korea

Phone +82 2 558 7267
Fax +82 2 558 3910

Genie Africa

Phone +27 11 455 0373
Fax +27 11 455 0355

Genie Latin America

Phone +55 11 4055 2499
Fax +55 11 4043 1661

Distributed By: