

Opportunities for Combined Heat and Power in Data Centers



March 2009

Prepared for:

Oak Ridge National Laboratory
Subcontract Number: 4000021512



Prepared by:
Ken Darrow
Bruce Hedman
ICF International
1655 N. Fort Myer Drive
Arlington, VA 22209

DOCUMENT AVAILABILITY

Reports produced after January 1, 1996, are generally available free via the U.S. Department of Energy (DOE) Information Bridge.

Web site <http://www.osti.gov/bridge>

Reports produced before January 1, 1996, may be purchased by members of the public from the following source.

National Technical Information Service
5285 Port Royal Road
Springfield, VA 22161
Telephone 703-605-6000 (1-800-553-6847)
TDD 703-487-4639
Fax 703-605-6900
E-mail info@ntis.gov
Web site <http://www.ntis.gov/support/ordernowabout.htm>

Reports are available to DOE employees, DOE contractors, Energy Technology Data Exchange (ETDE) representatives, and International Nuclear Information System (INIS) representatives from the following source.

Office of Scientific and Technical Information
P.O. Box 62
Oak Ridge, TN 37831
Telephone 865-576-8401
Fax 865-576-5728
E-mail reports@osti.gov
Web site <http://www.osti.gov/contact.html>

This report was prepared as an account of work sponsored by an agency of the United States Government. Neither the United States Government nor any agency thereof, nor any of their employees, makes any warranty, express or implied, or assumes any legal liability or responsibility for the accuracy, completeness, or usefulness of any information, apparatus, product, or process disclosed, or represents that its use would not infringe privately owned rights. Reference herein to any specific commercial product, process, or service by trade name, trademark, manufacturer, or otherwise, does not necessarily constitute or imply its endorsement, recommendation, or favoring by the United States Government or any agency thereof. The views and opinions of authors expressed herein do not necessarily state or reflect those of the United States Government or any agency thereof.

Energy and Transportation Science Division

Opportunities for Combined Heat and Power in Data Centers

Prepared by
Ken Darrow
Bruce Hedman
ICF International
55 N. Fort Myer Drive
Arlington, VA 22209
under Subcontract 4000021512

Date Published: March 2009

Prepared for
OAK RIDGE NATIONAL LABORATORY
Oak Ridge, Tennessee 37831-6283
managed by
UT-BATTELLE, LLC
for the
U.S. DEPARTMENT OF ENERGY
under contract DE-AC05-00OR22725

Table of Contents

	Page
List of Figures	v
List of Tables	vii
Abbreviated Terms.....	ix
Acknowledgements.....	xi
Introduction.....	1
Data Center Market Segmentation.....	1
Business Applications.....	2
Facility Size	3
Geographic Markets.....	5
Data Center Availability Classification System and Standard	7
Growth Forecasts	9
Data Center Energy Use Trends	9
Overall Market Energy Use and Growth	9
Data Center Energy Usage Profile.....	11
Data Center Cooling	13
Power Conditioning, UPS, and Backup Power.....	18
CHP Applicability and Configuration for Data Centers.....	20
CHP Technologies	20
Absorption Chiller Matching to CHP	22
On-site Power Generation and Power Reliability for Data Centers	23
CHP Economics	25
Data Center Loads for CHP Economic Analysis.....	26
CHP Equipment Selection and Sizing	28
CHP Payback Analysis	30
Primary Energy and GHG Comparison	34
Energy Efficiency Metric for Data Centers	40
Examples of CHP Systems in Data Centers and Facilities with Data Processing Loads	41
Example Fuel Cell Application.....	41
Example Gas Turbine Application.....	43
CHP Market Drivers and Hurdles.....	44
CHP Market Drivers for Data Centers.....	44
Barriers to CHP Implementation in Data Centers.....	45
CHP Paths to Market	46
Conclusions.....	48

List of Figures

Figure	Page
1: Primary Internet Cable Connections and User Nodes.....	6
2: Collocation Facilities Top 20 States.....	6
3: Projected 5-Year Electricity Consumption Growth in Data Centers by Market Segment, Assuming Continuation of Current Energy Trends	11
4: Examples of Data Center Energy Usage Shares	12
5: Average Computer Room Energy Usage Intensities in the LBNL Benchmarking Study.....	13
6: HVAC Share of Total Data Center Loads.....	14
7: Typical Data Center HVAC Hot Aisle Cold Aisle Layout	15
8: Server Rack and Air Conditioning Layout for a 10,000 sq. ft Data Center at 500 W/sq. ft.	15
9: Increase in Power Densities for IT Equipment	18
10: Power Layout for 25,000 sq. ft. Data Center in San Diego, California	19
11: CHP System Layout for Data Center	20
12: Sensitivity of Payback to Average Electric Rate.....	33
13: Schematic of CHP Efficiency and GHG Emissions Benefits for 5 MW of Core Load	34
14: NERC Subregions	37
15: Comparison of Primary Energy Savings, 1,000 kW IT Case.....	39
16: GHG Emissions Savings, 1,000 kW IT Case	39
17: GHG Emissions Savings, 10,000 kW IT Case.....	40

List of Tables

Table	Page
1: Data Center Types	3
2: Data Center Market Segments.....	4
3: Estimated Number of Data Centers by Size	5
4: Tier Classification Comparison.....	7
5: Energy Use for Data Centers.....	9
6: Server/Data Center Growth by Facility Size.....	10
7: Data Center Electric Capacity Requirements by Year	11
8: Overall Dedicated Computer Facility Electric Load Calculation	16
9: Cooling Electrical Requirements as a Function of Cooling System Type and Efficiency	17
10: CHP Technology Types for Data Center Applications	21
11: Nominal 1,000 kW Efficient IT Load Analysis	27
12: Nominal 10,000 kW IT Load Analysis	28
13: Example CHP Systems Cost and Performance for 1,000 and 10,000 Nominal IT Load Cases.....	29
14: Representative CHP Economics in Best Practices Facility.....	31
15: CHP Paybacks for Alternative Facility Configurations	33
16: U.S. Combined Marginal Grid GHG Intensity Factors.....	36
17: Energy and GHG Emissions for Nominal 1,000 kW Efficient IT Case Analysis.....	37
18: Energy and GHG Emissions for Nominal 10,000 kW Efficient IT Case Analysis.....	38
19: Primary Energy DCIE	41
20: CHP Installations in Data Center and Communications Facilities.....	42

Abbreviated Terms

ASHRAE	American Society of Heating Refrigeration and Air-Conditioning Engineers
CAGR	Compound annual growth rate
CHP	Combined heat and power
CoLo	Co-located server hosting facility
COP	Coefficient of performance
CRAC	Computer room air conditioner
CRAH	Computer room air handler
cfm	Cubic feet per minute
DCIE	Data center infrastructure efficiency
DX	Direct expansion air conditioner
EER	Energy efficiency ratio
eGRID	Emissions & Generation Resource Integrated Database (maintained by the U.S. Environmental Protection Agency)
EPO	Emergency power off switch
ESB	Emergency supply bus
EUI	Energy Usage Intensity
FEMP	Federal Energy Management Program
GHG	Greenhouse gas emissions
HHV	Higher heating value
HVAC	Heating, ventilation, and air conditioning
IT	Information technology, used here to refer to the computer equipment electric load
LEED	Leadership in Environmental and Energy Design
MSB	Master supply bus
NAICS	North American Industrial Classification System
NERC	North-American Electricity Reliability Corporation
O&M	Operating and maintenance
PAFC	Phosphoric acid fuel cell
PDU	Power distribution unit
PEM	Proton exchange membrane fuel cell
PUE	Power usage effectiveness
RD&D	Research, development, and demonstration
Recip	Reciprocating engine generator
RPP	Remote power panel
T&D	Electric transmission and distribution
Telco	Telecommunication facility
UPS	Uninterruptible Power Supply
VoIP	Voice over internet protocol
VR	Voltage regulator

Acknowledgments

This report and the work described were sponsored by the U.S. Department of Energy (DOE) Office of Energy Efficiency and Renewable Energy (EERE) Industrial Technologies Program. The authors gratefully acknowledge the support and guidance of Paul Scheihing, Bob Gemmer, and Amy Manheim at DOE. The authors thank several Oak Ridge National Laboratory staff who have made contributions to the report, including Patti Garland, Abdi Zaltash, and Ed Pierce.

The authors also wish to thank the many industry experts for their thorough review and constructive recommendations, including Dale Sartor and William Tschudi at Lawrence Berkeley National Laboratory; Kenneth Brill and Vince Renaud at the Uptime Institute, Inc.; Bob Tierney, Tim Wagner, Rob Roche, David Paul, and Ed Baker at United Technologies; Tom Pierson, Gary Hilberg, and Don Fiorino at Turbine Air Systems; and Joe McGervey at Energetics, Inc.

Introduction

Data centers represent a rapidly growing and very energy intensive activity in commercial, educational, and government facilities. In the last five years the growth of this sector was the electric power equivalent to seven new coal-fired power plants. Data centers consume 1.5% of the total power in the U.S. Growth over the next five to ten years is expected to require a similar increase in power generation. This energy consumption is concentrated in buildings that are 10-40 times more energy intensive than a typical office building. The sheer size of the market, the concentrated energy consumption per facility, and the tendency of facilities to cluster in “high-tech” centers all contribute to a potential power infrastructure crisis for the industry.

Meeting the energy needs of data centers is a moving target. Computing power is advancing rapidly, which reduces the energy requirements for data centers. A lot of work is going into improving the computing power of servers and other processing equipment. However, this increase in computing power is increasing the power densities of this equipment. While fewer pieces of equipment may be needed to meet a given data processing load, the energy density of a facility designed to house this higher efficiency equipment will be as high as or higher than it is today. In other words, while the data center of the future may have the IT power of ten data centers of today, it is also going to have higher power requirements and higher power densities.

This report analyzes the opportunities for CHP technologies to assist primary power in making the data center more cost-effective and energy efficient. Broader application of CHP will lower the demand for electricity from central stations and reduce the pressure on electric transmission and distribution infrastructure.

This report is organized into the following sections:

- **Data Center Market Segmentation** – the description of the overall size of the market, the size and types of facilities involved, and the geographic distribution.
- **Data Center Energy Use Trends** – a discussion of energy use and expected energy growth and the typical energy consumption and uses in data centers.
- **CHP Applicability** – Potential configurations, CHP case studies, applicable equipment, heat recovery opportunities (cooling), cost and performance benchmarks, and power reliability benefits
- **CHP Drivers and Hurdles** – evaluation of user benefits, social benefits, market structural issues and attitudes toward CHP, and regulatory hurdles.
- **CHP Paths to Market** – Discussion of technical needs, education, strategic partnerships needed to promote CHP in the IT community.

Data Center Market Segmentation

A data center is a facility used for housing a large amount of electronic equipment, typically computers and communications equipment. It generally includes environmental controls (air conditioning, fire suppression, etc.), redundant/backup power supplies, redundant data

communications connections and high security. As the name implies, a data center is usually maintained by an organization for the purpose of handling the data necessary for its operations. A bank for example may have a data center, where all its customers' account information is maintained and transactions involving these data are carried out. Practically every company that is mid-sized or larger has some kind of data center with the larger companies often having dozens of data centers. Most large cities have many purpose-built data center buildings in secure locations close to telecommunications services. Most co-location centers and Internet peering points are located in these kinds of facilities.

In this section the market is segmented three ways

1. by business application
2. by facility size
3. by power security/reliability
4. by geographic location

Business Applications

There are several categories of data centers as shown in **Table 1**¹: While these applications often have quite different functions, there is a continuing process of technical convergence making these applications more similar. For example, server systems are beginning to be used to replace mainframe computers; telephone systems are transitioning to internet operations.²

Data centers are classified under the North American Industrial Classification System (NAICS) in two specific places:

- Online Information Services – NAICS 514191– Internet access providers, Internet service providers, and similar establishments engaged in providing access through telecommunications networks to computer-held information compiled or published. Server Farms Fall In This Area.
- Data Processing Services – NAICS 5142 –Establishments providing electronic data processing services. These establishments may provide complete processing and preparation of reports from data supplied by customers; specialized services, such as automated data entry services; or may make data processing resources available to clients on an hourly or timesharing basis.

¹ ACEEE: *Overview of Data Centers and Their Implications for Energy Demand*, Elizabeth Brown, R. Neal Elliott, and Anna Shipley, American Council for an Energy-Efficient Economy, Washington, DC, September 2001

² William Ryan, *Targeted CHP Outreach in Selected Sectors of the Commercial Market*, for Oak Ridge National Laboratory, The University of Illinois at Chicago, Chicago, Illinois

Table 1: Data Center Types

Telecoms	Telecommunication switches. These are known as telecoms or telcos. These are more energy demanding than typical Internet data centers. ³
ISP's	Internet service providers
CoLos	Co-located server hosting facilities, also known as CoLos, where rack space is leased by tenants and computer equipment is owned and operated by tenants. Because tenants may move in and out, upgrade their computers frequently, and have a disconnect between the energy-using facility and the billing department, energy demands tend to have greater fluctuations and to be less well characterized than corporate data centers.
Server Farms	Data storage and hosting facilities ("internet hotels"). These facilities are built specifically for data storage, and often are maintained by a single company (even if it is a company that rents out servers to outsourcing groups), and therefore the whole building can be built or retrofitted to the owners needs, including energy needs.
Internet Hotels	Similar to Server Farms
Corporate Data Centers	Corporate data centers, include both servers and mainframe computers. These are the oldest types of data centers.
University, National Laboratory	High performance computing (supercomputers or clusters)

Data centers are used by all medium to large businesses to a greater or lesser extent. The need is very high for banks and other financial institutions, insurance companies, health care providers, and large retail operations with online purchasing. Of course, internet service providers are a large source of the growing need for server farms.

Facility Size

Recent analyses by EPA and LBNL have characterized the data center market into five categories by analyzing sales of servers – the primary functional and energy using component of data centers.^{4,5}

Table 2 defines the five market segments. Server closets and server rooms, as their names suggest, are part of other facilities, such as small to medium sized businesses whose data needs are relatively limited. While there are large numbers of these closets and rooms spread throughout the economy, they do not represent a distinct target for CHP. CHP systems are

³ *Energy Smart Data Centers: Applying Energy Efficient Design And Technology To The Digital Information Sector*, Fred Beck*Renewable Energy Policy Project, November 2001, No. 14

⁴ Report to Congress on Server and Data Center Energy Efficiency: Public Law 109-431, U.S. Environmental Protection Agency ENERGY STAR Program, August 2, 2007.

⁵ Jonathan G. Koomey, *Estimating Total power Consumption by Servers in The U.S. and the World*, Lawrence Berkeley National Laboratory, February 15, 2007.

Table 2: Data Center Market Segments

Space type	Typical size	Typical IT equipment characteristics	Typical site infrastructure system characteristics
Server closet	<200 sq. ft.	1-2 servers. No external storage.	Typically conditioned through an office HVAC system. To support VoIP and wireless applications, UPS and DC power systems are sometimes included in server closets. Environmental conditions are not as tightly maintained as for other data center types. HVAC energy efficiency associated with server closets is probably similar to the efficiency of office HVAC systems
Server room	<500 sq. ft.	A few to dozens of servers. No external storage.	Typically conditioned through an office HVAC system, with additional cooling capacity, probably in the form of a split system specifically designed to condition the room. The cooling system and UPS equipment are typically of average or low efficiency because there is no economy of scale to make efficient systems more first-cost competitive.
Localized data center	<1,000 sq. ft.	Dozens to hundreds of servers. Moderate external storage.	Typically use under-floor or overhead air distribution systems and a few in-room CRAC units. CRAC units in localized data centers are more likely to be air cooled and have constant-speed fans and are thus relatively low efficiency. Operational staff is likely to be minimal, which makes it likely that equipment orientation and airflow management are not optimized. Air temperature and humidity are tightly monitored. However, power and cooling redundancy reduce overall system efficiency.
Mid-tier data center	<5,000 sq. ft.	Hundreds of servers. Extensive external storage.	Typically use under-floor air distribution and in-room CRAC units. The larger size of the center relative to those listed above increases the probability that efficient cooling, e.g., a central chilled water plant and central air handling units with variable speed fans, is used. Staff at this size data center may be aware of equipment orientation and airflow management best practices. However, power and cooling redundancy may reduce overall system efficiency.
Enterprise-class data center	5,000+ sq. ft.	Hundreds to thousands of servers. Extensive external storage	The most efficient equipment is expected to be found in these large data centers. Along with efficient cooling, these data centers may have energy management systems. Equipment orientation and airflow management best practices are most likely implemented. However, enterprise-class data centers are designed with maximum redundancy, which can reduce the benefits gained from the operational and technological efficiency measures.

applied on a facility basis. The presence of data loads within a building, on the other hand, could make it more attractive for CHP by providing a core 24/7 load.

Stand-alone facilities vary in size and purpose from small localized data centers up to large enterprise class facilities. As shown in **Table 3**, there are 13,000 to 19,500 of these stand alone facilities. These facilities represent the target for CHP application. Further, the largest 1,000 to 2,500 Enterprise Class facilities potentially represent a very attractive target due to the large concentrated power loads.

Table 3: Estimated Number of Data Centers by Size

Facility Types	Volume Servers	Estimated Servers per facility	Estimated Number of Facilities	2006 Electric Use billion kWh
Server Closets	1,798,000	1-2	900,000-1,500,000	3.5
Server Rooms	2,120,000	3-36	50,000-100,000	4.3
Localized data center	1,820,000	36-300	10,000-13,000	4.2
Mid-tier data center	1,643,000	300-800	2,000-4000	3.7
Enterprise-class data center	3,215,000	800-2000+	1,000-2500	8.8

Source: Energy Use EPA, 2007

The characterization of the market by concentration of servers at locations does not fully describe how these servers function within a given facility, what power and cooling is required, or how these requirements dictate the floor space requirements and layout. Server technology is advancing over time. New servers process more information and typically require greater power. In addition, an approach called virtualization can make more effective use of available equipment. Greater concentrations of power directly affect the cooling and power conditioning requirements, and the design and effectiveness of these systems determines how much floor space can be devoted to IT equipment versus cooling and power conditioning equipment.

Geographic Markets

Data centers and servers tend to cluster in specific areas based on the availability of broadband width data communication data transmission facilities. Systems that need direct access to the internet are located in major hubs such as San Francisco/San Jose/Silicon Valley region, New York, Boston, and the Orlando/Tampa area. These locations are based on major high-speed optical cable connections shown in **Figure 1**.

Collocation (or *colocation*) facilities represent a segment of the data center industry that provides rack space for lease to other businesses. Companies that build and operate their own data centers are often very secretive about the size and capabilities, even the location of such facilities. Collocation facilities, however, must publicize their location and capabilities to

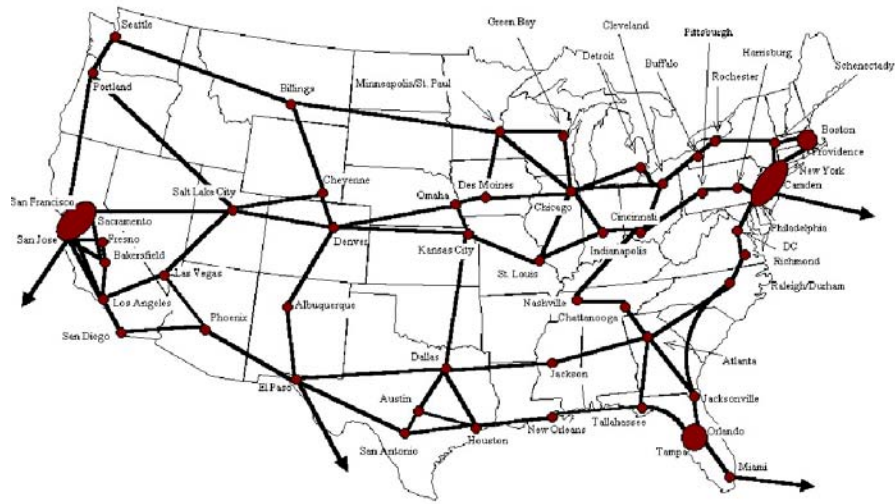

Figure 1: Primary Internet Cable Connections and User Nodes⁶

attract business tenants. As such, the geographical distribution of these facilities provides a good indication of where CHP opportunities might be for the industry as a whole. There are a total of 1,164 facilities in the U.S. (compared to the 13,000-19,000 local, mid-tier, and enterprise class facilities identified in **Table 3**.) **Figure 2** shows the top 20 states in terms of number of facilities. These 20 states represent 85% of the total number of collocation facilities.

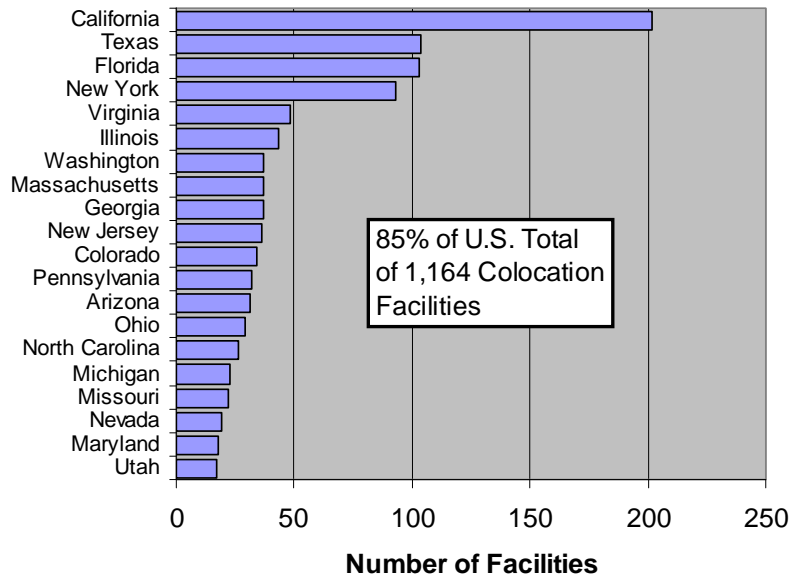

Figure 2: Collocation Facilities Top 20 States⁷

⁶ ACEEE: Overview of Data Centers and Their Implications for Energy Demand, Elizabeth Brown, R. Neal Elliott, and Anna Shipley, American Council for an Energy-Efficient Economy, Washington, DC, September 2001. Original Data from [FCC] Federal Communication Commission. 2000. Deployment of Advanced Telecommunications Capability. Washington, DC: FCC.

Data Center Availability Classification System and Standard

The datacenter industry has developed a four-level *Tier Performance Classification and Standard* to describe the expected availability of datacenter operations within a facility. This system was developed by Uptime Institute and has been adopted as the industry standard.^{8,9} the individual tiers represent categories of site infrastructure topology that address increasingly sophisticated operating concepts, leading to increased site infrastructure availability. The four tiers, summarized in **Table 4**, can be described as follows:

Table 4: Tier Classification Comparison

Facility Characteristics	Tier I	Tier II	Tier III	Tier IV
Number of Delivery Paths	1	1	1 active, 1 passive	2 active
Redundant Components	N	N + 1	N + 1	minimum N + 1
Support Space to Raised Floor Ratio	10%	30%	80-90%	100%
Initial W/s.f.	20-30	40-50	40-60	50-80
Ultimate W/s.f.	20-30	40-50	100-150	150+
Raised Floor Height, inches	12	18	30-36	30-36
Floor loading, lb/sq.ft	85	100	150	150+
Utility Voltage	208, 480	208, 480	12-15 kV	12-15 kV
Months to Implement	3	6-Mar	15-20	15-20
Year of First Deployment	1965	1970	1995	1995
Representative Planned Maintenance Shutdowns	2 Annual 12 hour shutdowns	3 Events over 2 years at 12 hours each	None Required	None Required
Representative Site Failures	6 Failures over 5 years	1 Failure Each Year	1 Failure every 2-5 years	1 Failure every 5 years
Expected Annual IT Downtime, hrs	28.8	22	1.6	0.8
Site Availability	99.671%	99.749%	99.982%	99.991%

Source: *The Uptime Institute*

- A Tier I basic data center provides an improved environment over that of an ordinary office setting and includes a dedicated space for IT systems, a UPS to filter power spikes, sags, and momentary outages, dedicated cooling equipment that is not shut down at the end of normal office hours, and an engine generator to protect IT functions from extended power outages. Tier I sites typically experience two separate 12-hour, site-wide shutdowns per year for maintenance and on average 1.2 forced outages each year for a total expected outage time of 28.8 hours per year (99.67% availability.) Tier I is appropriate for small businesses using IT primarily for internal

⁷ www.colosource.com, April 21, 2008

⁸ W. Pitt Turner, et al., *Tier Classifications Define Site Infrastructure Performance*, White Paper, uptime Institute, Inc.

⁹ TIA-942, *Data Center Standards Overview*, ADC, Inc.

purposes or for companies whose web presence is primarily as a passive marketing tool.

- A Tier II data center includes redundant critical power and cooling capacity components to provide an increased margin of safety against IT process disruptions from site infrastructure maintenance or failures. The redundant components are typically extra UPS modules, chillers, heat rejection equipment, pumps, cooling units, and engine generators. Tier II facilities have reduced requirements maintenance related shut-downs and a somewhat reduced expectation of an IT disruption due to a system failure; the expected downtime for a Tier II facility is 22 hours per year (99.75% availability.) Tier II is appropriate for call centers where multiple sites are available or internet-based companies without significant quality of service financial penalties.
- A Tier III data center adds the additional concept of concurrent maintenance – meaning that every capacity or distribution component necessary to support the IT function can be maintained on a planned basis without impact to the IT function. A redundant delivery path for power and cooling is added to the Tier II topology. This concept extends to important subsystems such as control systems for the mechanical plant, start-up systems for engine generators, EPO controls, power sources for cooling equipment, pumps, isolation valves, and others. A Tier III facility requires no IT downtime for infrastructure maintenance and only a once in 2.5 years likelihood of a 4-hour IT outage; this performance results in an expected 1.6 hours/year of IT disruption (99.98% availability.) A Tier III facility is appropriate for companies that support internal and external clients 24x7, such as service centers and help desks, but can accept limited periods of service interruption.
- A Tier IV data center builds on Tier III infrastructure design topology by adding the concept of fault tolerance. Fault tolerance extends to each and every system or component that supports IT operations. Tier IV design topology allows for failure of any system or component or groups of systems without creating a disruption of IT operations. Tier IV facilities can expect only one 4-hour IT disruption in five years – 0.8 hours per year (99.99% availability.) Companies that go to the expense of Tier IV design typically have an international market presence and have highly critical, real time E-commerce business operations that would be prohibitively costly to interrupt.

Uptime Institute does offer facility certification. However, it is often common practice for facilities to assert Tier III and Tier IV capabilities without any outside verification.

There are programs available for Tier level certification, but many more facilities self certify their tier level, without outside verification. Such facility claims of availability and security may not meet the required function and topologies that are in the classification standard.

Growth Forecasts

The data center market has been growing at 13-16% CAGR (compound annual growth rate) and expectations for the future are for growth to be around 5-10% per year.¹⁰ Floor space will grow more slowly than energy use due to the trend toward higher power densities in servers.

There is a trend toward consolidation of smaller facilities into much larger facilities. A trade publication in 2006 predicted that the number of Enterprise Class data centers in the U.S. could more than double in as little as three years as companies continue to consolidate their IT infrastructure away from smaller, more distributed IT centers.¹¹ Estimated growth for the market is discussed in detail in the Energy Use Section.

Data Center Energy Use Trends

This section describes the energy use profile and growth trends for data centers.

Overall Market Energy Use and Growth

As of 2006, the electricity use attributable to the nation's servers and data centers is estimated at about 61 billion kilowatt-hours (kWh), or 1.5 percent of total U.S. electricity consumption (EPA 2007). This electricity use has more than doubled since 2000 and amounts to about \$4.5 billion in electricity costs. The estimate of electricity use is based on the sales of servers by type and associated equipment load estimates, shown in **Table 5**. These same growth estimates are allocated to facility size class in **Table 6**.

Table 5: Energy Use for Data Centers

End Use Component	2000		2006		2000-2006 electricity CAGR
	Electricity Use (billion kWh)	% Total	Electricity Use (billion kWh)	% Total	
Site Infrastructure	14.1	50%	30.7	50%	13.8%
Network Equipment	1.4	5%	3	5%	13.5%
Storage	1.1	4%	3.1	5%	18.8%
High-End Servers	1.1	4%	1.5	2%	5.3%
Mid-range Servers	2.5	9%	2.2	4%	-2.1%
Volume Servers	8.0	28%	20.9	34%	17.4%
Total	28.2	100%	61.4	100%	13.8%

Source: (EPA 2007)

¹⁰ EPA, op cit., August 2, 2007.

¹¹ "Data Center of the Future Poised to Address Key Challenges," *CRM Today*, March 29, 2006.

Table 6: Server/Data Center Growth by Facility Size

Space Type	2000		2006		2000-2006 electricity CAGR
	Electricity Use (billion kWh)	% Total	Electricity Use (billion kWh)	% Total	
Server Closet	3.0	11%	7.5	12%	16.5%
Server Room	3.9	14%	9.7	16%	16.4%
Localized Data Center	4.9	17%	11.1	18%	14.6%
Mid-tier Data Center	4.4	16%	10.0	16%	14.7%
Enterprise Class Data Center	12.0	43%	23.0	38%	11.5%
Total (may vary due to rounding)	28.2	100%	61.4	100%	13.8%

The recent historical energy growth for all data centers is 13.8% per year. In the largest size category, the growth rate was 11.5% per year.

Based on the historical energy consumption, EPA projected a 5-year energy consumption growth to 124.5 billion kWh in 2011 representing a 16% CAGR. However, server technology and data center design has been changing significantly. EPA projected a more moderate growth rate to 107.4 billion kWh, 12% CAGR, based on a continuation of current energy efficiency trends:

- Virtualization impact – Growth in volume servers needed reduced by 4% and all other types of servers by 8% by 2011
- Server efficiency – 5% of volume server shipments in 2007 and 15% of shipments in 2011 to be high efficiency.
- Power management controls – enabled on 10% of applicable servers.
- Energy storage efficiency – energy use per enterprise storage device will drop 7% by 2011.
- Infrastructure efficiency – PUE¹² ratio drops from 2.0 to 1.9 by 2011 for all space types because of improved technological and operation performance of site infrastructure systems.

The year-by-year growth tracks for data centers are shown in **Figure 3**.

Table 7 shows the estimated electric capacity requirements to meet the data center electricity loads. These assumptions are based on data center load factors of 80-100%. The EPA/LBNL estimates for 2006 show that data centers required electric capacity of between 7,000 to

¹² Power Usage Effectiveness = Total data center energy use to total IT equipment energy use. Koomey, LBNL 2007 measure the average PUE for existing data centers of about 2.0.

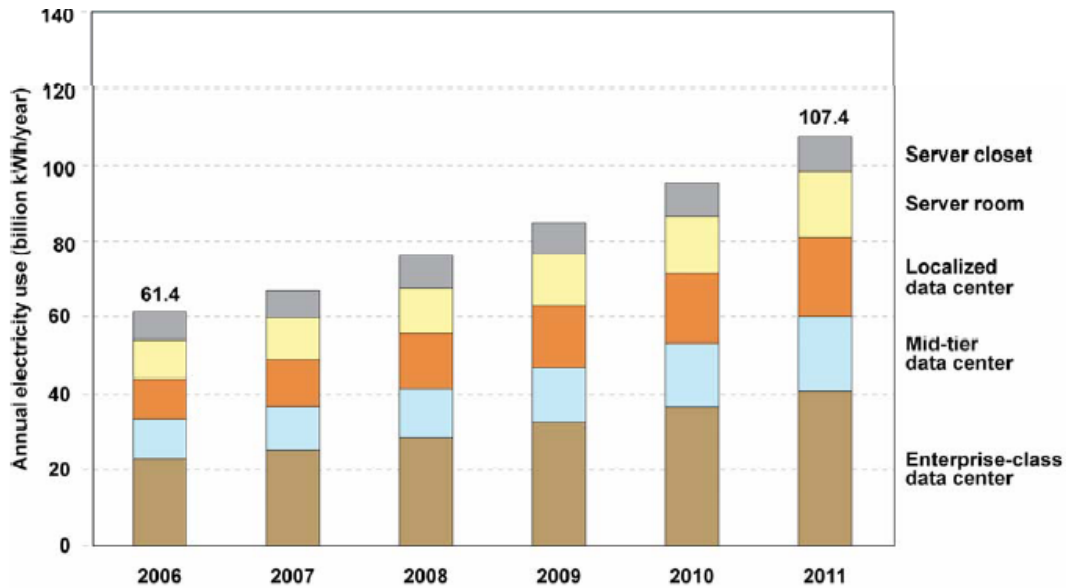

Figure 3: Projected 5-Year Electricity Consumption Growth in Data Centers by Market Segment, Assuming Continuation of Current Energy Trends

Table 7: Data Center Electric Capacity Requirements by Year

Year	Electric Consumption (billion kWh)	MW Total Load @ 100% Load Factor	MW Total Load @ 80% Load Factor	MW Load Growth (100% LF)	MW Load Growth (80% LF)
2000	28.2	3,219	4,024		
2006	61.4	7,009	8,761	3,790	4,737
2011	107.4	12,260	15,325	5,251	6,564

8,800 MW. Five-year growth projections are for an additional 5,300 to 6,600 MW of new capacity or a growth of 75% in the next five years.

Data Center Energy Usage Profile

Data centers, compared to other business activities within commercial buildings, are characterized by very high electricity consumption for a given floor area. The ratio of energy or power demand requirements as a function of building size are defined as the energy usage intensity (EUI) of the building measured in Watts/sq.ft or, on an annual basis, kWh/sq.ft. Data centers exhibit EUIs that typically range from 20-90 Watts/square foot or even higher on a continuous basis. This is much higher than the average office building that has an average electricity usage intensity of only about 2 Watts/square foot. Data centers have the following main types of electric loads:

IT Load

- Servers, the predominant IT load
- Data Storage
- Network Communications

Infrastructure Load

- Lighting
- UPS/Power conditioning
- Air conditioning

LBLN has undertaken an extensive benchmarking study of energy usage patterns in data centers. Two energy usage breakdowns are shown in **Figure 4**.¹³ In the first example, the computer room loads average about half of the total building energy use. Air conditioning related loads represent another third of the building's energy budget. Other loads including the energy use by UPS, battery cycling, etc. represent 14% and lighting only 2%. The second example shows a facility with more efficient support infrastructure loads. The computing load is two-thirds of the total building load with cooling, fan power making up 31% of the total and lighting the remaining 2%.

The LBNL benchmarking study shows that data centers vary widely in the IT share of total load from 35-75%. A facility that has very efficient infrastructure loads will show the IT load as being a higher percentage of total loads than a facility that has inefficient infrastructure loads.

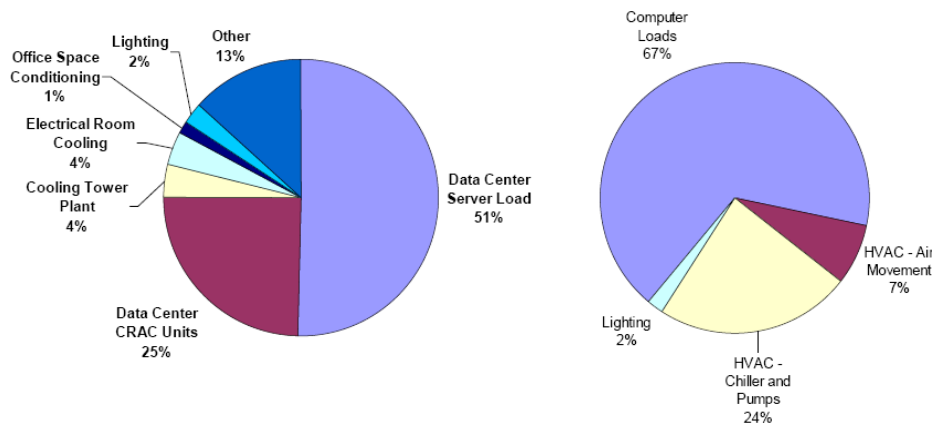

Source: Tschudi, LBNL, 2006

Figure 4: Examples of Data Center Energy Usage Shares

Typical IT loads for the computer room, shown in **Figure 5**, were measured at an average of 25 Watts/square foot in 2003. In 2005, the average IT equipment load had increased to

¹³ William Tschudi, "Demonstrations to Illustrate Energy Efficiency Opportunities in Data Centers," Lawrence Berkeley National Laboratories, ASHRAE Winter Meeting, January, 2006.

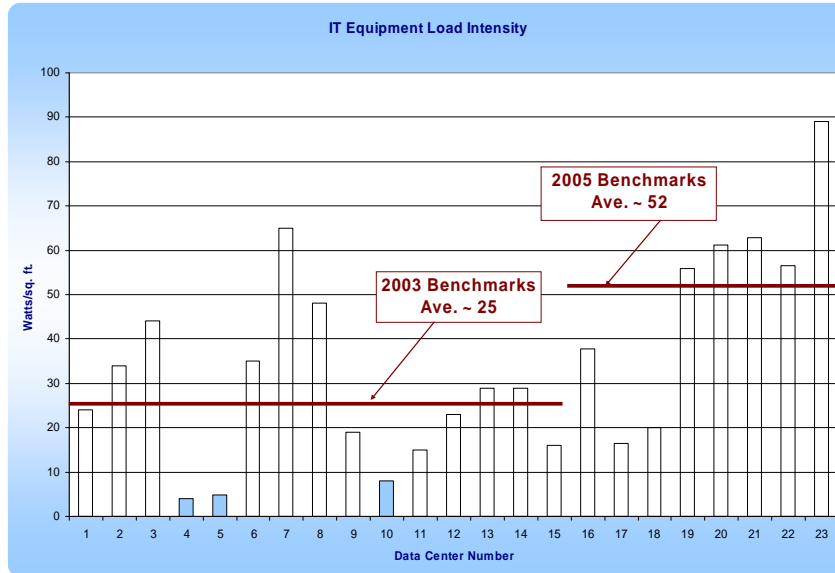

Source: LBNL Data Center Benchmarking Study¹⁴

Figure 5: Average Computer Room Energy Usage Intensities in the LBNL Benchmarking Study

52 Watts/square foot. There is debate about exactly how high these IT power loads will go in the future, but there is consensus that power loads will continue to increase.

A large share of the infrastructure loads is in the removal of the computer room and auxiliary heat from the building. According to the benchmarking, air conditioning loads (HVAC) vary from 20-50% of total building loads (see **Figure 6**).

The HVAC loads represent an opportunity for integration with a CHP system that provides heat activated cooling. Therefore, data center air conditioning is described in detail in the next section.

Data Center Cooling¹⁵

The primary goal of data center air conditioning systems is to keep the server components at the board level within the manufacturer's specified temperature/humidity range. This is critical since electronic equipment in a confined space generates heat, and higher temperatures tend to increase failure rates over long periods of time or in extreme overheating the equipment will self-regulate to avoid failure (slow processing or shut down). Air conditioning systems also help keep humidity within recommended parameters. ASHRAE has developed recommended and allowable ranges of temperature and humidity for data centers. Recommended temperature delivery to the server inlet is kept between 68-77°F. The recommended humidity range is between 35% and 55 % Relative Humidity

¹⁴ William F. Tschudi, *LBNL Benchmarking Study Curriculum*, provided by the author, August 6, 2008.

¹⁵ Information in this section from Ron Hughes, "Data Centers of the Future," California Data Center Design Group, *Data Center Journal Online*, May 2005.

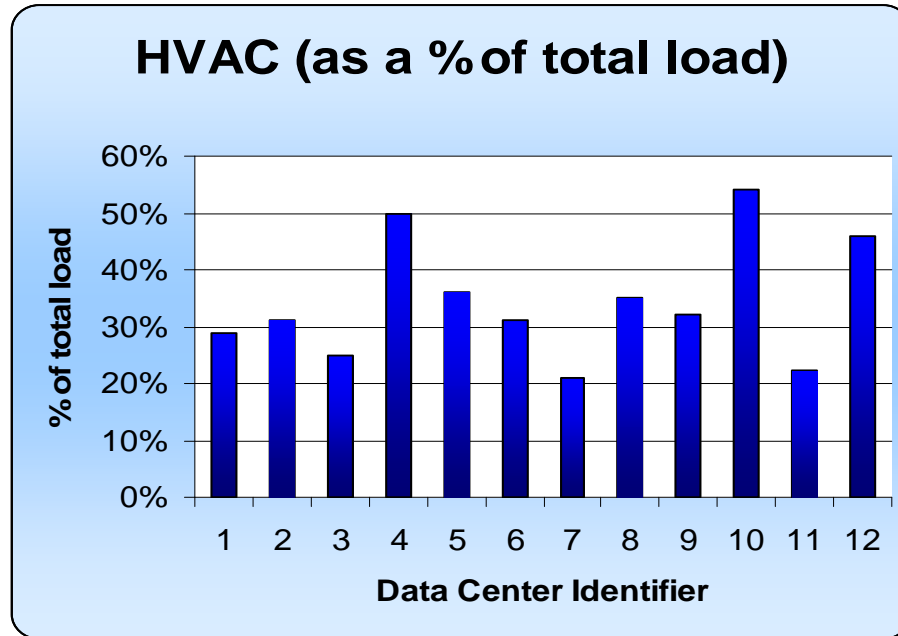

LBNL Benchmarking (2004¹⁶)

Figure 6: HVAC Share of Total Data Center Loads

however there is evidence that broader ranges may be acceptable. ASHRAE is initiating research aimed at broadening the recommended range.

A common computer room ventilation configuration is shown in **Figure 7**. The computer rooms are on a raised floor that serves as the conditioned air delivery system. Overhead air delivery is an optional delivery method. It is standard terminology to refer to the square footage of a data center that is devoted to computer equipment as the *electrically active floor area*. Computer room air conditioning units (CRACs) or air handling units (CRAHs) utilizing chilled water deliver cold air under the floor (or from overhead) in alternating aisles called a hot aisle/cold aisle layout. The hot air is removed overhead. To put the cooling load in perspective, an IBM series Blade center (racks of servers) requires 24 kW of power in a 2'x3.5'x6' space. All of this power is converted to heat. Therefore, each of these racks requires 6.8 tons of air conditioning.

While average power densities for IT equipment are in the 20-90 W/sq.ft. range, power densities could grow as high as 500 W/sq. ft. As power densities go up, the floor space required for infrastructure increases correspondingly, limiting the available space for the IT equipment. **Figure 8** illustrates the number of computer room air conditioning (CRAC) units required for a 10,000 square foot data center at 500 watts a square foot. CRAC units typically use refrigerant to exchange heat with water cooled condensers that are tied into cooling towers for heat removal. In other configurations the CRACs are replaced by computer room air handling units (CRAHs) that are tied into a central water chiller.

¹⁶ Cited in Jonathan Koomey, "Data Center Power Use: A Review of the Historical Data," IBM Conference on Energy Efficient Design, Austin, Texas, March 2, 2004.

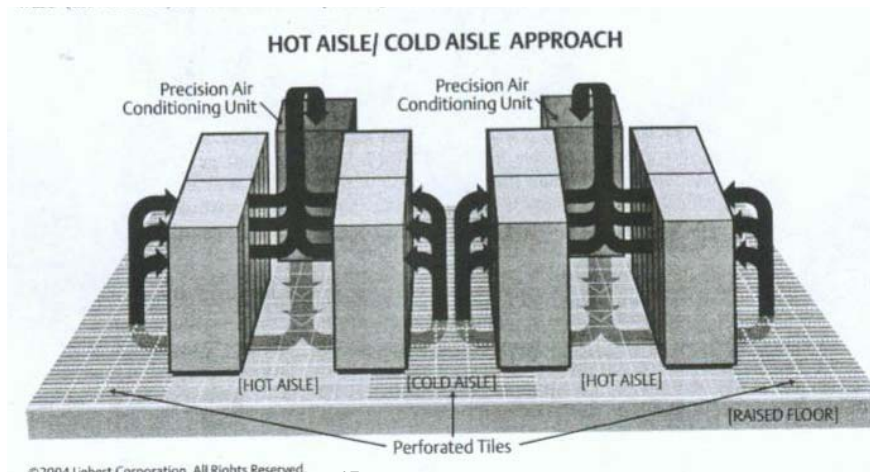

Source: Liebert Corporation¹⁷

Figure 7: Typical Data Center HVAC Hot Aisle Cold Aisle Layout

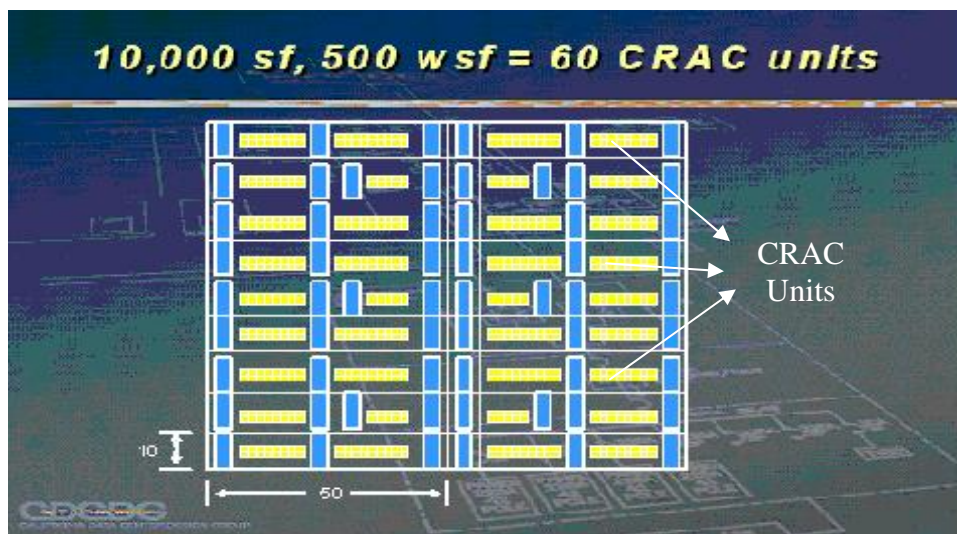

Source: Ron Hughes, California Data Center Design Group

Figure 8: Server Rack and Air Conditioning Layout for a 10,000 sq. ft. Data Center at 500 W/sq. ft.

Integration of the cooling loads with a CHP would require the use of a central, thermally activated chiller and CRAHs. Alternatively, there is some interest in the design of water or liquid cooling for the racks. Water cooling would be more space and energy efficient and would also be tied into a central chiller supplied by the heat from a CHP system.

¹⁷ Cited in Jack Pouchet, "Creating Energy Efficient Data Centers," *Energy & Power Management*, January 2007.

Table 8 defines a characteristic load for a datacenter based on an assumed IT load of 25 Watts/sq. ft.¹⁸ Lighting load of 2.5 Watts/sq. ft. are assumed. Cooling is required to remove the heat produced by the IT power, the lighting, and HVAC fans distributed throughout the space. The total heat removal required from the space is 31.38 Watts/ sq/ ft. This cooling requirement is equivalent to 9.05 tons/1,000 sq. ft. (0.00905 tons/sq. ft.). The total constant power requirement for the facility with cooling added is 39.08 Watts/sq. ft.

Table 8: Overall Dedicated Computer Facility Electric Load Calculation¹⁹

Total Facility Power Usage		
Internal Loads		
Computer Loads, PDUs, UPS	25	Watts/sq. ft.
Lighting Loads	2.5	Watts/sq. ft.
Fan Power	4.33	Watts/sq. ft.
Total Electric Loads	31.83	Watts/sq. ft.
Internal Heat Loads	108.65	Btu/sq.ft./Hour
Internal Heat Loads	0.00905	tons/sq. ft.
Air Flow Required*	4.69	cfm/sq. ft.
Theoretical Fan Power**	0.00261	hp/sq. ft.
Actual Fan Power***	0.00523	hp/sq. ft.
Fan Motor Power ****	4.33	Watts/sq. ft.
Cooling System		
Chiller System Power Usage*****	7.24	Watts/sq. ft.
Total Facility Usage	39.08	Watts/sq. ft.
<p>* Air Flow Based on Air Supplied at 55°F and Leaving at 80°F ** Theoretical Fan Power Based on 5 inches of Water Column Pressure Drop *** Actual Fan Power Based on 50% Fan Efficiency **** Fan Motor Power Based on 90% Efficient Motor ***** Chiller System Power Usage is 0.8 kW/ton times the Internal Heat Loads in Tons/sq. ft. The 0.8 total includes chiller (0.55 kW/ton) + Cooling Tower and Pumps (0.15 kW/ton) and Chilled Water pumps (0.1 kW/ton). If Rooftop Units are Used the 0.8 goes to 1.1 kW/ton, after netting out fan power.</p>		

Source: ERC University of Illinois at Chicago

The energy required for cooling the data center is a direct function of the efficiency of the cooling equipment. **Table 9** shows how cooling load shares vary as a function of the cooling

¹⁸ It is common practice in the industry to measure the IT load in Watts per square foot of raised floor area. In this example, the load is measured in Watts/sq. ft. of total floor area. The raised floor area is assumed to be 50% of the total floor area so the IT load is assumed equal to 50 Watts/sq/ ft. of raised floor area.

¹⁹ William Ryan, ERC .

Table 9: Cooling Electrical Requirements as a Function of Cooling System Type and Efficiency

Cooling Load Analysis	Rooftop DX Cooling		Centrifugal Chiller	
	Typical Installed	High Efficiency	Typical Installed	High Efficiency
Internal Electric Loads, kW	1,000	1,000	1,000	1,000
Internal Cooling Load, tons	284	284	284	284
Rated EER	8.5	13	n.a.	n.a.
Cooling COP	2.5	3.8	4.6	7.3
Cooling Load, kW/ton	1.41	0.92	0.76	0.48
Ventilation Fan, kW/ton	0.48	0.22	0.48	0.22
Added Pump Loads, kW/ton	n.a.	n.a.	0.25	0.25
HVAC Total, kW/ton	1.89	1.14	1.49	0.95
HVAC Energy Required, kW	539	325	425	270
Total Building Load, kW	1,539	1,325	1,425	1,270
HVAC Share of Total, %	35.0%	24.5%	29.8%	21.3%

Sources: Equipment efficiencies are from the EIA National Energy Modeling System Annual Energy Outlook 2007, the fan air flow requirements from UIC/ERC.

system that is used. All of the calculations are based on a 1,000 kW internal electric load. Standard efficiency air cooled air conditioners typically installed today have a rated energy efficiency ratio (EER) of 8.5 Btu/Watt. High efficiency equipment is available with an EER of 13 Btu/Watt. Buildings that use chillers can provide cooling more efficiently, though there are additional pumping loads that must be added to the chiller efficiency numbers to arrive at total cooling efficiency. The table shows that a typical data center today would have an HVAC load equal to 35% of the total building load. The use of a high efficiency chiller can bring the HVAC electric requirements down considerably such that the HVAC load is only 21.3% of the total. This change results in an 18% reduction in total building electric requirements compared to a typical system with rooftop cooling.

Not only are the power and cooling needs intense, but also they are projected to become steadily higher. **Figure 9** shows how current developments in more powerful and smaller electronics are projected to increase power usage and heat release rates over the next few years.

Meeting the energy needs of data centers is a moving target. Computing power is advancing rapidly, which reduces the energy requirements for data centers. A lot of work is going into improving the computing power of servers and other processing equipment. However, this increase in computing power is increasing the power densities of this equipment. While fewer pieces of equipment may be needed to meet a given data processing load, the energy density of a facility designed to house this higher efficiency equipment will be as high as or

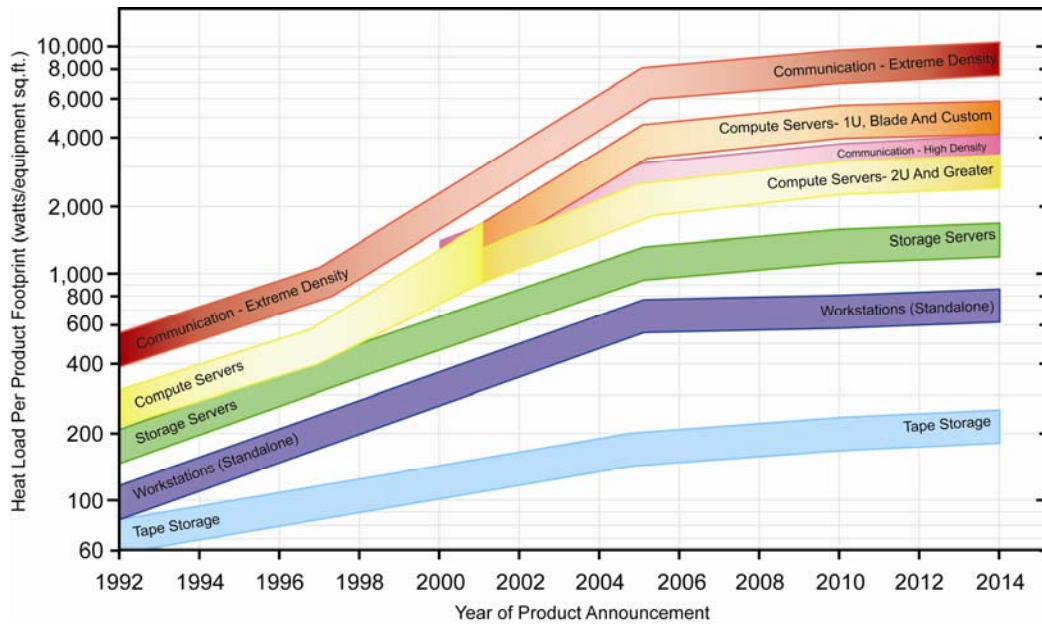

Figure 9: Increase in Power Densities for IT Equipment (adapted from ASHRAE TC 9.9 artwork).²⁰

higher than it is today. In other words, while the data center of the future may have the IT power of 10 data centers of today, that one data center is going to have electric and cooling load densities that are as high or higher than the data centers of today.

Power Conditioning, UPS, and Backup Power

A key aspect of any data center is their need for a continuous supply of power to the facility. This requirement must be preserved when adding CHP to the supply of electricity. In addition, cooling is also a critical requirement to maintain the reliability of server IT operations. The contribution that CHP can make to continuous secure power for a facility will be described in the next section. This section provides several examples of different power conditioning and backup power technology configurations used by data centers.

A continuous supply of power is essential to avoid equipment downtime. For such highly critical equipment, the cost of being offline, even for a short period, can run into the millions of dollars. The power conditioning system and back-up energy storage can also add a significant energy load to a data center.

Figure 10 shows one example of a schematic of the power supply for a 25,000 square foot colocation data center in San Diego.²¹ The facility operators cite their power design as an example of 2N Architecture – all required power services are backed up into two separate

²⁰ Watts/Equipment sq. ft. shown in the figure is for the equipment footprint only and does not include aisles and other building space either within or outside of the raised floor area of the data center.

²¹ <http://www.americanis.net/index.php>

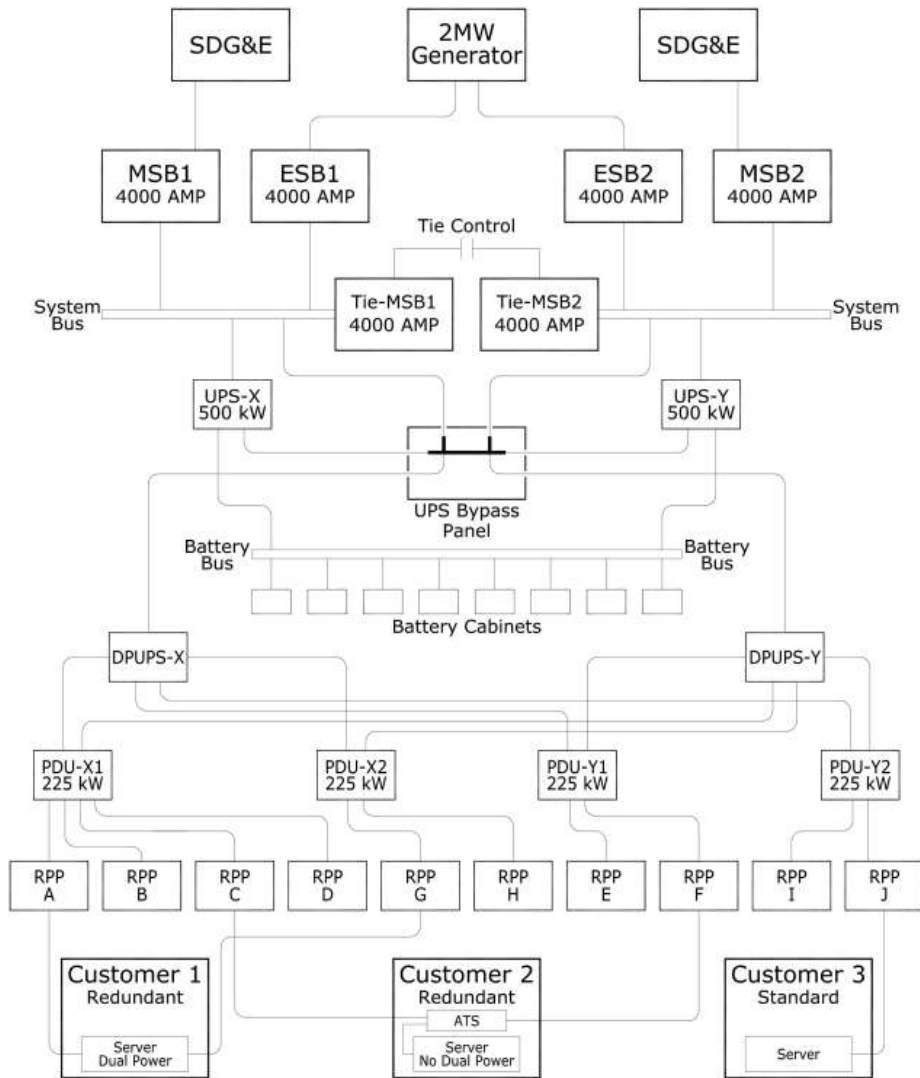

Figure 10: Power Layout for 25,000 sq. ft. Data Center in San Diego, California

and redundant systems that are each capable of meeting the entire facility load.²² The facility has two separate 4,000 ampere, 480 Volt feeds from the utility each to an individual master supply bus (MSB). This system provides automatic switching between two independent transformers located on the property. In the event of an extended power outage, diesel generators capable of supplying either of two independent emergency supply busses (ESB) provide input power to the facility. There are 3,500 gallons of on-site diesel storage on the facility capable of providing over 24 hours at maximum power. The system can be refueled while operating.

²² According to the Tier classification system, to truly qualify as a Tier III facility, there would need to be redundant on-site power supply. The redundant utility feeds would not qualify for a high Tier rating.

The facility has one megawatt of redundant UPS power and a fully redundant 2,400 ampere, 48V, positive ground DC battery power plant and distribution system. UPS power is fed into redundant Power Distribution Units (PDU) and from there into Remote Power Panels (RPP). Each RPP is monitored to the circuit breaker level to ensure early warning overload protection.

CHP Applicability and Configuration for Data Centers

Because data centers have high electricity and cooling requirements and operate continuously with nearly constant load, they represent good candidates for CHP. Heat recovered from the onsite power generation unit in the form of steam or hot water can be utilized by a thermally activated cooling system. Most commonly, this cooling system is an absorption chiller. The basic components for a CHP system in a data center are shown in **Figure 11**. The data center would typically have two or three power sources: primary power is provided by the CHP system, back-up power can be provided seamlessly from the utility feed through the UPS system, and a second back-up in highly critical applications can be provided by a second utility feed or standby diesel generators (not shown.) The CHP system also provides chilled water through an absorption (or adsorption) chiller. The absorption chiller is backed-up by one or more back-up electric chillers that draw power from the critical load panel.

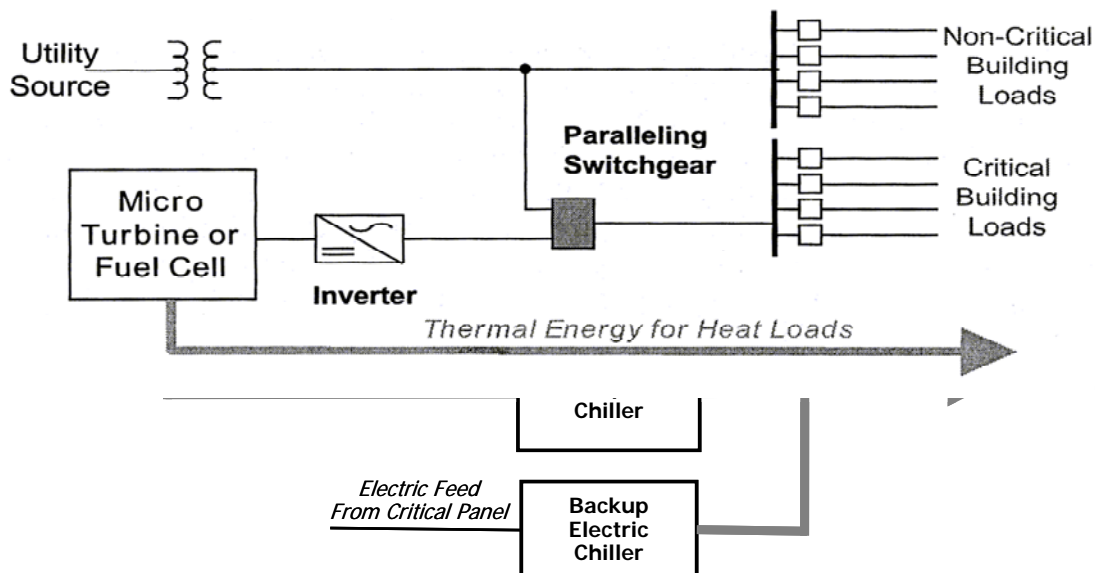

Note: generic schematic only, not a specific Tier Classification topology

Figure 11: CHP System Layout for Data Center

CHP Technologies

CHP is the simultaneous production of multiple forms of useful energy (usually electrical and thermal) in a single, integrated system. CHP systems consist of a number of individual components – prime mover (heat engine), generator, heat recovery, and electrical interconnection – configured into an integrated whole. The type of equipment that drives the overall system (i.e., the prime mover) typically identifies the CHP system. Prime movers for

CHP systems include mature, higher volume technologies like reciprocating engines, combustion or gas turbines as well as commercially proven but lower volume technologies such as microturbines and fuel cells. The lower volume technologies however, are cleaner and benefit from very attractive government incentives, particularly for fuel cells. These prime movers are capable of utilizing a variety of fuels, including natural gas, coal, oil, and alternative fuels to produce shaft power to drive an electric generator.

Table 10 compares the four main CHP technologies that could be used in data center applications. Fuel cells, reciprocating engines, and microturbines are typically utilized for CHP systems smaller than 5 MW. These technologies would be appropriate for smaller data centers. Often systems are designed around multiple prime movers, a feature that can enhance overall system reliability. While there are gas turbines available in sizes of less than 1 MW, they typically are more economic in larger sizes. Gas turbines are most economic in sizes above 5 MW to the largest data centers that have been announced – roughly 50 MW.

Table 10: CHP Technology Types for Data Center Applications

CHP system	Advantages	Disadvantages	Available Sizes and Costs
Gas Turbine	<ul style="list-style-type: none"> • High reliability. • Low emissions. • High grade heat available for double effect absorption chiller • Well sized for new enterprise class data centers. • Small federal incentive available (~ 10% of cost if overall efficiency is 60% or greater) 	<ul style="list-style-type: none"> • Require high pressure natural gas or an in-house gas compressor. • Poor efficiency at low loading. • Output falls as ambient temperature rises. • May produce more cooling than the data center needs. • Requires additional operations and maintenance by experienced operations staff or outsource 	500 kW to 40 MW \$1,200-2,500/kW
Microturbine	<ul style="list-style-type: none"> • Small number of moving parts. • Compact size and light weight. • Low emissions. • Can be matched to direct-fired exhaust driven double effect absorption chiller. • Power electronics could be modified for future DC power data center • Small federal incentive available (~ 10% of cost if overall efficiency is 60% or greater) 	<ul style="list-style-type: none"> • High costs, few active vendors • Relatively low electrical efficiency. • Poor efficiency at low loading. • Output falls as ambient temperature rises. • Limited choice of direct exhaust fired chillers. 	30 – 1,000kW \$2,000-3,000/kW

Table 10: (continued)

CHP system	Advantages	Disadvantages	Available Sizes and Costs
Spark Ignition (SI) Reciprocating Engine	<ul style="list-style-type: none"> • High power efficiency with part-load operational flexibility. • Fast start-up. • Relatively low investment costs. • Can be used in island mode and have good load following capability. • Operate on low-pressure gas. • Small federal incentive available (~ 10%of cost if overall efficiency is 60% or greater) 	<ul style="list-style-type: none"> • High maintenance costs. • Limited to lower temperature cogeneration applications. • Relatively high air emissions (difficulty permitting in some areas) • Must be cooled even if recovered heat is not used. • High levels of low frequency noise. • Generally limited to single effect absorption chiller, though larger engines could use exhaust heat for double effect chillers. 	High speed (1,200 RPM)
			<4MW \$1,500-2,500/kW
Fuel Cells	<ul style="list-style-type: none"> • Lowest emission profile of any other on-site power generation technology • Electrochemical fuel conversion, No combustion • No noise, allowing indoor installation • High efficiency over load range. • Modular design. • High temp technologies can use double effect absorption chillers • Tax credits and other incentives available • DC power generation could be used directly in data center of the future • Large federal incentive available (\$3,000/kW or 30%of cost, whichever is less) 	<ul style="list-style-type: none"> • High capital costs • Industry is less mature • Power density is lower with efficiency reductions over the product life. • Fuels requiring processing unless pure hydrogen is used. • Requirement for stack replacement produces a high maintenance cost allocation 	Low speed (60-275 RPM)
			200 – 1,200 kW \$4,000-6,000/kW

Source: Adapted from *Catalog of CHP Technologies, EPA CHP Partnership Program prepublication draft, July 2008.*

These characterizations relate to economic and performance issues. In order to qualify as a secure source of supply under current Tier classification performance criteria, all on-site generating equipment must have on-site fuel storage.

Absorption Chiller Matching to CHP

The type of absorption chiller used is typically a function of the quality of waste heat that is available from the CHP system. Phosphoric acid fuel cells, reciprocating engines, and microturbines typically co-produce hot water. High temperature hot water near or above the

boiling point (under pressure) can power a single effect absorption chiller. Gas turbines, reciprocating engine exhaust, high temperature fuel cells (molten carbonate, solid oxide) and, microturbines are capable of producing steam that can be used to drive an indirect-fired steam driven double effect absorption chiller. In alternative designs, the hot exhaust gases from a turbine or microturbine are used directly to provide the thermal energy to drive double effect absorption chiller. An indirect-fired steam driven double effect absorption chillers can produce a ton of cooling (12,000 Btu/h) with 10,000 Btu/h of steam (COP = 1.2). A single effect absorption chiller needs about 17,000 Btu/h of low pressure steam or high temperature hot water (~190°F) to produce a ton of cooling (COP = 0.7). Reciprocating engines and phosphoric acid fuel cells both produce thermal energy that can drive a single effect absorption chiller cycle. PEM fuel cells do not produce thermal energy of a high enough quality to drive even a single effect absorption cycle; so they are not considered to be an appropriate candidate for data center CHP. PEM fuel cells have been applied in data centers as a small backup power system.

Absorption chillers would be used in a data center with computer room air handlers. In the future, the chilled water or another liquid could be fed directly to liquid cooled racks. Absorption chillers require larger cooling tower capacity than standard electric chillers and more pumping power. The tower load is equal to the building load multiplied by the factor $(1 + 1 / \text{Chiller COP})$, that is the tower must reject the heat of the building plus the heat created by the inefficiency of the chiller. Since electric chillers have COPs approaching 6 and the efficiency of a double effect absorption chiller is about 1.2, the tower cooling load is about 50% larger with the absorption chiller than with the electric chiller. The size of the tower can be managed by increasing the temperature differential of the input and output tower water.

On-site Power Generation and Power Reliability for Data Centers

Data centers require both high-quality and extremely reliable power for IT operations. Data centers, telecommunication facilities, and other mission-critical computer systems have the highest costs associated with power outages or lapses in power quality. A momentary outage that disrupts critical loads can take a datacenter down for four hours and cost around \$20 million.²³

CHP systems for data centers need to be integrated with a number of other systems designed to provide continuous high quality power. Data centers must have UPS systems to provide power conditioning and “ride-through” time for power transitions from one source of power to another or switching in the distribution system. Data centers often have more than one utility feed and associated seamless switching equipment, though in the Tier Classification standard the presence or absence of utility feeds does not define the Tier classification level. The tier level is defined by the number, capacity, and topology of the on-site engine generators. Batteries or other energy storage media are used to provide a short-term outage ride-through of a few minutes to an hour.

²³ Kenneth G. Brill, Uptime Institute, personal communication, August 21, 2008.

CHP systems have a track record of operational availability²⁴ in the mid to high 90% range. In a review of the operational availability of CHP systems conducted for Oak Ridge National Laboratory, reciprocating engine availability factors averaged 96-98% and gas turbines averaged 93-97%.²⁵ In a separate study, commercial fuel cells showed a similar availability factor of 95%.²⁶ For all on-site generation systems, more than half of the downtime is for scheduled maintenance, meaning that the facility can schedule it ahead of time to ensure that all other back-up systems are operating properly. On-site power generation, whether it is an engine, fuel cell, microturbine, or other prime mover, supports the need for reliable power by protecting against long-term outages.

CHP systems that operate continuously provide additional reliability compared to emergency backup generators that must be started up during a utility outage. Backup generators typically take 10 to 30 seconds to pick up load in the case of an outage and can even fail to start if not properly maintained and frequently tested.

CHP systems, specifically the power generation component, applied to data centers should be designed to contribute to the overall electric reliability design of the facility. Currently, the availability/security Tier Classification Standard requires on-site fuel storage for the on-site generators that are defined as the dedicated source of power supply. This requirement, as currently interpreted, would not allow a CHP system fueled with pipeline natural gas to serve as the dedicated source of supply. It appears that the industry has defined the standard around the known risks associated with the installation of diesel generators as the defined dedicated source of supply, such as failure to start, fuel contamination, and inability to get additional oil deliveries in an extended area-wide disruption. The standards deal with these risks by requiring redundant capacity, redundant controls, and a minimum of 36-72 hours of on-site fuel storage. The risks associated with a natural gas fueled CHP system, such as disruption of the gas pipeline, supply shortage, and the introduction of additional technology into the facility do not seem arguably greater than the risks associated with the specification of diesel engines. These risks could be similarly managed. However, the industry, to date, has yet to interpret the performance standard to include gas fueled CHP as an alternative option.

- In a basic Tier I facility, the CHP system could replace the diesel back-up generator
- In a Tier II facility, the CHP system could replace a portion of the redundant on-site power supply capacity
- In Tier III and Tier IV facilities, which often have redundant utility feeds, the CHP system could replace one of the utility feeds as an additional “economic alternative” and not as the defined “dedicated source of supply.” In this configuration, the N + X or 2N capacity of diesel generators would remain the same. Since utility feeds are not counted as a secure source of power, the replacement of one of these feeds with a

²⁴ The availability factor is the proportion of hours per year that a unit “could run” (based on planned and unplanned maintenance), divided by the total hours in the year.

²⁵ Distributed Generation Operational Reliability and Availability Database, ICF International, Inc. (as EEA, Inc.), for Oak Ridge National Laboratory, January 2004.

²⁶ ²⁶ Isom, J. and Paul, R., “The PureCell™ Fuel Cell Powerplant – A Superior Cogeneration Solution from UTC Power”, 2006 Fuel Cell Seminar p. 227-229.

CHP system should not affect the Tier Classification. Alternatively, the CHP system could functionally replace a portion of the redundant generation capacity. However, as previously stated, this would require a re-evaluation of the accepted way in which tier Certification is derived.

CHP systems also provide cooling, another critical load support system. For a data center or other critical load environment, the cooling provided by the CHP system from the absorption chillers needs to be backed up by electric chillers that can assume the load when the CHP system is not operating. The favored topology is for redundant parallel paths with redundant control systems, chilled water pumps, electric boards, etc. One developer²⁷ is working on designs with the absorption chiller in series with a larger electrically operated screw compressor. When the absorption chiller is operating, the electric chiller has a reduced inlet water temperature and operates at part load very efficiently. When the CHP system is down, the electric chiller picks up the full load. In Tier III and IV installations, thermal storage may be used for ride-through capability. Absorption chillers with proper design and controls are as reliable as electric chillers with comparable maintenance costs. Absorption chillers can operate with varying tower water temperature down to 60°F.

The redundant back-ups, utility standby, and seamless, fault tolerant switchgear all add to the cost the facility. CHP systems are an additional capital cost. However, unlike a typical datacenter backup generators, the CHP system is contributing to reduction in the facility operating costs.

CHP Economics

From an energy usage standpoint, data centers are very similar. They have high and fairly constant electric loads, and this electric load contributes to high building cooling loads. Therefore, a CHP system needs to provide power for the base electric load and cooling to remove the heat that electric load generates. The electric efficiency of the CHP system and the efficiency of the thermally activated cooling combine to determine the ratio of power to cooling that can be provided. Some technologies such as gas turbines provide more cooling than is needed when the generator is sized to the building base electric load. Others, such as fuel cells, provide less cooling than is needed, so the CHP provided cooling is used to supplement electric cooling. The CHP system is most cost effective and energy efficient when the utilization of power and thermally activated cooling is maximized. Therefore, CHP systems with a higher ratio of cooling to power than is needed by the facility should be sized to the cooling load to achieve full utilization and maximize the economic value proposition for the end user.

The economics can be very favorable for technologies that receive generous Federal and State incentives. Though reciprocating engines, microturbines, and gas turbines receive incentives, fuel cells enjoy very significant incentives, as much as \$3,000/kW or 30% of project costs, whichever is less. So though fuel cells are a fairly new entrant to the market, these government incentives make them highly competitive while manufacturers are driving down costs.

²⁷ Bob Tierney, Private Communication, UTC, July 24, 2008.

Data Center Loads for CHP Economic Analysis

Data centers require continuous power and cooling. All of the power consumed by the facility within the building space is converted to heat which must be removed by cooling. Whether the data center is making effective use of its IT power load or not or whether the efficiency of the infrastructure supporting that IT load is efficient or not, or whether the energy density is higher or lower, the CHP system will see virtually continuous power demand and have to remove heat from the building in a ratio of 0.28 tons of cooling per kW of power delivered to the space.²⁸ This means that the design of a CHP system and the ratio of cooling required for a dedicated data center will be fairly uniform regardless of what other IT or infrastructure improvements are included in the facility design.

This section will outline the energy requirements for an example server facility today providing a given amount of computing or IT capability. The effects of first improving the IT capability to power ratio through such measures as virtualization and shut-down of obsolete or idling IT equipment will be shown. After improving the IT capability, the effect of improving the supporting electric infrastructure will be shown. The CHP system will be applied to the facility with the improved IT capability and the improved infrastructure. This approach has been taken in order to highlight the primary or source energy and greenhouse gas impacts of each measure. In addition, it makes economic sense for the data center industry to first improve IT capability to power ratios and lower the energy infrastructure requirements through state-of-the-art facility design and equipment selection before considering investment in CHP.

Two example size classes are considered. The first, is a nominal 1,000 kW IT load (optimized high efficiency capacity) and the second is a nominal 10,000 kW IT load (optimized high efficiency capacity).

The load for a nominal 1,000 kW efficient IT load is shown in **Table 11**. This facility is shown in three configurations:

- **Typical 2008 Energy Consumption** – a facility with 2,000 kW of *un-optimized* IT capacity, and inefficient power supplies, lighting, and comparatively inefficient direct expansion air conditioning using CRACs. This facility is assumed to have a power density for the raised floor area of 100 W/sq.ft. The raised floor area is 20,000 sq.ft and the total building size is 40,000 sq.ft.
- **Optimized IT Facility** – This facility assumes that same IT capability can be provided with half of the power through virtualization, removal of obsolete servers, and shutdown of standby or idling equipment. Therefore the same IT capability requires only half the power of the first case, or 1,000 kW. With this efficiency improvement to IT, it was assumed that the power density would be maintained such that the size and supporting power demand of the facility required serving this IT capability would be cut in half.
- **Optimized IT with High Efficiency Infrastructure** – In this case, an improved electric infrastructure is assumed with average 85% efficient power supply and

²⁸ One kW used within the facility generates 3,412 Btu of heat. One ton of cooling equals 12,000 Btu for a ratio of 0.28 tons/kW.

improved lighting efficiency. The improvement in power supply reduces the cooling load for the building. This case replaces the inefficient DX cooling equipment with a water cooled electric chiller providing chilled water to computer room air handlers (CRAHs). A water side economizer is added to the facility to reduce the annual cooling load requirements by 28%.²⁹

Table 11: Nominal 1,000 kW Efficient IT Load Analysis

Building Loads	Typical Energy Consumption - 2008		Optimize IT: Virtualization, Power Management		Best Practices Consumption - 2008	
	Peak kW	Annual MWh	Peak kW	Annual MWh	Peak kW	Annual MWh
IT Load (incl. server fans)	2,000	17,520	1,000	8,760	1,000	8,760
PSU, UPS, VRs, PDU	1,200	10,512	600	5,256	176	1,546
Lighting	80	701	40	350	30	263
CRAC/CRAH Fans	284	2,485	142	1,243	73	637
Cooling Water Pump	0	0	0	0	36	319
Cooling Tower	0	0	0	0	36	319
DX or Chiller	1,115	9,767	557	4,883	218	1,377
Total Facility Load	4,679	40,985	2,339	20,493	1,570	13,220
<i>Facility Base Electric Load</i>	3,564		1,782		1,352	
Cooling Load, Tons	1,013		507		364	
Cooling Power, kW/ton	1.10		1.10		0.60	
Cooling COP	3.20		3.20		5.86	
Free Cooling Share	0%		0%		28%	
Cooling Power/Total Power		29.9%		29.9%		20.1%
<i>DCIE</i>		42.7%		42.7%		66.3%

Doubling the “IT capability to power ratio” in itself reduces power requirements by 50%. A system with optimized IT and high efficient energy infrastructure uses only 32% of the energy for the same IT capability as a typical data center today. The data center infrastructure efficiency (DCIE) is a measure of the ratio of the IT load to the total building load.

$$DCIE = IT\ Load / Total\ Building\ Load$$

The higher the ratio, the less additional energy is required to support the IT load. In the example shown, the DCIE will increase from 42.7% to 66.8%. Higher levels of DCIE are possible with development of IT equipment that is direct liquid cooled or with other long term possibilities such as DC power distribution. The improvement in data center efficiency will not be evidenced by data centers using less energy per square foot in the future but in providing much more IT capability in facilities that have the same or possibly higher power densities than are seen today. The overall improvement would be evidenced by a reduction in the number or size of future data centers.

²⁹ Free cooling savings vary with climate. This example is based on Northeast location.

A similar analysis was conducted for a nominal 10,000 kW efficient IT load as shown in **Table 12**. Assumptions for the three categories are identical to the 1,000 kW case.

Table 12: Nominal 10,000 kW IT Load Analysis

Building Loads	Typical Energy Consumption - 2008		Optimize IT: Virtualization, Power Management		Best Practices Consumption - 2008	
	Peak kW	Annual MWh	Peak kW	Annual MWh	Peak kW	Annual MWh
IT Load (incl. server fans)	20,000	175,200	10,000	87,600	10,000	87,600
PSU, UPS, VRs, PDU	12,000	105,120	6,000	52,560	1,765	15,459
Lighting	800	7,008	400	3,504	300	2,628
CRAC/CRAH Fans	2,837	24,854	1,419	12,427	727	6,372
Cooling water Pump	0	0	0	0	364	3,186
Cooling Tower	0	0	0	0	364	3,187
DX or Chiller	11,149	97,669	5,575	48,834	2,183	13,768
Total Facility Load	46,787	409,851	23,393	204,925	15,703	132,201
<i>Facility Base Electric Load</i>	<i>35,637</i>		<i>17,819</i>		<i>13,520</i>	
Cooling Load (tons)	10,133		5,066		3,637	
Cooling kW/ton	1.10		1.10		0.60	
Cooling COP	3.20		3.20		5.86	
Free Cooling Share	0%		0%		28%	
Cooling Power/Total Power		29.9%		29.9%		20.1%
<i>DCIE</i>		<i>42.7%</i>		<i>42.7%</i>		<i>66.3%</i>

CHP Equipment Selection and Sizing

The optimal sizing strategy for CHP is to meet as much as possible of the 24/7 electric loads without having to cycle or export power and without delivering more thermal energy than is needed to meet the building cooling loads. **Table 13** shows example CHP systems for the two example IT cases. For the nominal 1,000 kW IT load case, reciprocating engine, microturbine, and phosphoric acid fuel cell systems are considered. The reciprocating engine and fuel cell both utilize single effect absorption chillers. Only about half of the available waste heat from the fuel cell is of a high enough temperature for the absorption chiller. The low temperature waste heat, in a cooling only application, is wasted. The microturbine system utilizes a double effect absorption chiller that is direct “fired” from the hot exhaust gases with no intermediate steam or hot water production step. For the nominal 10,000 kW IT case, a recuperated gas turbine with a direct-fired exhaust driven double effect absorption chiller is considered. This system provides power and cooling in nearly the exact ratio required – 0.29 tons/kW versus the required 0.28 tons/kW. These systems are representative of a variety of different CHP systems that could be utilized for data center applications. There are other prime mover and chiller pairings that could be made, for instance a recip engine and a double-effect absorption chiller. Alternative configurations should be evaluated for a specific site application.

Table 13: Example CHP Systems Cost and Performance for 1,000 and 10,000 Nominal IT Load Cases

Data Center Applications	1,000 kW IT load			10,000 kW IT load
CHP System	Jenbacher Recip J320V085	UTC PureComfort Model 400M	UTC PureCell Model 400	Solar Mercury 50 GT
System Type	Recip. Engine	Micro-turbine x 2	Fuel Cell x 3	Gas Turbine x 2
Chiller Type	Single Effect	Double Effect	Single Effect	Double Effect
Capacity kW	1,060	752	1,200	8,850
Thermal, Btu/kWh	4,259	4,937	4,270	2,937
Cooling tons	266	362	150	2606
Natural Gas Use MMBtu/hr	10.25	9.19	11.37	88.22
Heat Rate, HHV	9,668	12,221	9,471	9,968
Electric Efficiency	35.3%	27.9%	36.0%	34.2%
CHP Efficiency	79.4%	68.3%	81.1%	63.7%
Virtual Electric Eff.	40.6%	33.8%	39.7%	40.3%
tons/kWh	0.25	0.48	0.13	0.29
Installed Capital Cost w/o chiller, \$/kW	\$2,100	\$2,500	\$4,750	\$1,547
Absorption Chiller Installed Cost \$/ton	\$1,600	\$2,000	\$2,000	\$828
Absorption Chiller Installed Cost \$/kW	\$401	\$963	\$250	\$244
Total Capital Cost, \$/kW	\$2,501	\$3,463	\$5,000	\$1,791
Est. O&M costs \$/kWh	\$0.019	\$0.021	\$0.020	\$0.008

The economic analysis options are described as follows:

1,000 kW IT Load Case:

- A single reciprocating engine generator with heat recovery from the exhaust and jacket water provides 250°F hot water to drive a single effect absorption chiller. This class of industrial engine can operate 60,000 hours before the first major overhaul. The optimal sizing for this system is 1,352 kW to meet the base electric load. A reciprocating engine CHP system of this size will provide 336 tons of chilled water, or 93% of the facility cooling load. Back-up electric chillers provide supplementary and back-up cooling.
- Three Model 400M microturbines sized to meet the facility's 1,352 kW base load demand. These microturbines can operate for 10 to 20 years with overhaul at the end of every 5 years. This configuration will supply about 540 tons of cooling, which is more than the required facility cooling load. The additional thermal capacity of the

system can be used for either heating or cooling of the data center infrastructure. If all the cooling is utilized, the overall CHP efficiency will be about 83%.

- Three phosphoric acid fuel cells (PAFC) sized to meet the facility's 1,352 kW base load demand. Currently phosphoric acid fuel cells have a life expectancy of 20 years with a stack replacement at 10 years. The efficiency for fuel cell stack declines over its predicted 10 year life and the amount of waste heat increases accordingly. The values shown in the Table 13 are the average values over the 10-year period. About half of the thermal output from the system is available at a temperature suitable for use in a single effect absorption chiller which corresponds to 46% or 169 tons of cooling load that can be dedicated to the chosen CHP system. The additional low temperature waste heat is available for water heating or space heating – as is the case in the Verizon installation. One CHP fuel cell system designed by UTC uses an absorption chiller operating in series with an electric chiller (screw compressor) sized to meet the entire facility load. When the CHP system is operating, the absorption chiller pre-cools the chilled water, and the electric chiller, operating at part load, brings the chilled water down to the building delivery temperature. The advantage of this configuration is that the screw compressor operates very efficiently at part load and at low entry water temperatures. With this CHP system design the supplementary cooling requirements are met using about 40% less electric power than the same chiller operating at full load using the cooling tower water directly.

10,000 kW IT Load Case:

- A recuperated gas turbine sized for the base power demand of the facility would provide slightly more cooling than is required for the building. Therefore, the system was downsized to match the building's cooling load (3,637 tons). Such a system would meet 91% of the building's base electric load. The cooling system is a steam driven double effect absorption cooling system. One or more electric chillers would provide back-up cooling capability. Industrial gas turbines are capable of operating more than 20 years in the field with overhaul periods of 40,000 to 60,000 hours.

The thermally activated cooling was assumed in all cases to carry an electric parasitic load of 0.083 kW/ton (including 0.033 kW/ton for solution pumps³⁰ and 0.05 kW/ton added for the increased cooling tower capacity).

CHP Payback Analysis

The CHP system economics are shown in **Table 14**. In each case, the CHP system is applied to the data center with the efficient IT and high efficiency infrastructure (DCIE = 66.3%). Cases 1, 2, and 3 are the reciprocating engine and microturbine, and fuel cell respectively applied to the 1,000 kW efficient IT load case. Case 4 is the 10,000 kW efficient IT load case with the recuperated gas turbine.

The following observations can be derived from the analysis:

³⁰ Private Communication, Bob Tierney, UTC, June 18, 2008.

Table 14: Representative CHP Economics in Best Practices Facility

CHP Payback Analysis	1000 kW IT Case 1	1000 kW IT Case 2	1000 kW IT Case 3	10,000 kW IT Case 4
Internal Loads, kW	1,352	1,352	1,352	13,520
Cooling Load, kW	218	218	218	2,183
Total Loads, kW	1,570	1,570	1,570	15,703
Cooling Load, tons	364	364	364	3,637
Cooling Energy, kW/ton	0.6	0.6	0.6	0.60017585
Site Energy Costs		0		
Electricity, \$/kWh	\$0.12	\$0.12	\$0.12	\$0.12
Natural Gas, \$/MMBtu	\$7.50	\$7.50	\$7.50	\$7.50
CHP System	Recip Engine	Microturbine	PAFC	Gas Turbine
Chiller	Single Effect	Double Effect	Single Effect	Double Effect
Baseload Electric Capacity (kW) actual	1,352	1,352	1,352	12356
CHP Capacity, kW	1,060	752	1,200	8,850
CHP Installed Cost, \$/kW	\$2,100	\$2,500	\$4,750	\$1,547
Absorption Chiller Cost \$/ton	\$1,600	\$2,000	\$2,000	\$828
Absorption Chiller Capacity, tons	266	362	150	2,606
Chiller Cost, \$/kW	\$401	\$963	\$250	\$244
O&M Costs, \$/kWh	\$0.019	\$0.021	\$0.020	\$0.008
Electric Heat Rate (Btu/kWh), HHV	9,668	12,221	9,471	9,968
Total Recoverable Heat, Btu/kWh	4,259	4,937	3,825	2,937
Basic Building Operation				
Electricity Consumed, MWh	13,220	13,220	13,220	132,201
Gas Consumed	0	0	0	0
Energy Cost	\$1,586,414	\$1,586,414	\$1,586,414	\$15,864,135
CHP Building Operation				
Electricity Produced, MWh	8,821	6,258	9,986	73,650
Cooling Electricity Avoided, MWh	1,190	1,308	749	11,773
Supplementary Electric Cooling, MWh	187	69	627	1,992
Supplementary Electric other, MWh	3,022	5,585	1,857	44,783
Gas Consumed, MMBtu	85,282	76,481	94,581	734,167
CHP Annual Costs				
Electricity	\$385,057	\$678,477	\$298,120	\$5,612,956
Gas	\$639,615	\$573,606	\$709,359	\$5,506,251
O&M	\$167,605	\$131,421	\$199,728	\$589,198
Total CHP Annual Operating Costs	\$1,192,277	\$1,383,504	\$1,207,206	\$11,708,405
CHP Annual Savings	\$394,137	\$202,909	\$379,207	\$4,155,730
Total CHP System Cost	\$2,650,941	\$2,604,000	\$6,000,000	\$15,851,945
Federal Tax Rebates *	\$265,094	\$260,400	\$1,800,000	\$1,585,194
Net CHP Capital Cost	\$2,385,847	\$2,343,600	\$4,200,000	\$14,266,750
Payback, years	6.1	11.5	11.1	3.4

* Fuel cell CHP rebate equals 30% up to \$3,000/kW (as calculated in this example: FC = \$1,500/kW) other technologies receive 10% investment tax credit

- The gas and electric pricing are consistent with active CHP markets in the Northeast and in California.
- Reciprocating engine systems are competitive in applications that are too small for gas turbines. The need to use a single effect absorption chiller limits the overall effectiveness of the system. The payback of 6.1 years is marginally competitive based on the assumed electricity and natural gas prices.
- The microturbine installation has a lower electrical efficiency but a higher potential CHP efficiency if all the thermal capacity can be utilized. The ratio of cooling provided to electric provided for microturbines (0.48 tons/kW) is higher than the ratio of cooling required to base electric load (0.28 tons/kW) for the facility, so the microturbine system is sized to the cooling load. Due to the free cooling assumed in this best practices example, only 72% of the thermal energy from the CHP system can be utilized. This results in an uneconomic payback of 11.5 years for this system in this application.
- The phosphoric acid fuel cell installation has a higher electric generation efficiency when compared to both the reciprocating engine and the gas turbine systems, but provides only about half the amount of cooling in comparison to the reciprocating engine system. Only about half of the total thermal energy is at a high quality (temperature) that can be used for cooling. The economic payback of 11.1 years is based on using only this high temperature waste heat. Paybacks would be lower if there were a use for the low temperature heat stream as well.
- The recuperated gas turbine system applied in the 10,000 kW IT case provides the lowest payback at 3.4 years.
- 10% federal tax credits are available on all CHP systems up to 15MW with an overall efficiency of 60% or greater. The fuel cell system is eligible for a 30% tax credit.

The *best-practices* configuration for the preceding economic analysis does not make full use of the thermal energy from each system due to the use of *free-cooling* and the lack of heating or hot water loads at the facility. The reciprocating engine and gas turbine systems utilize 90% of the available thermal energy; the microturbine, with its cooling sized to the facility load, uses 72%; and the fuel cell, because the chiller is undersized, uses 100%. Using the same electric and gas price assumptions as in the best-practices case, other facility configurations could provide more attractive economic paybacks by utilizing more of the available thermal energy as shown in **Table 15**. All of the CHP systems, except for the fuel cell which is operating at full cooling capacity in the best practices case, benefit from a full utilization of cooling, i.e., no use of free cooling at the facility. Even with free cooling, if there were a use for the unused thermal energy during periods of low system cooling requirements (or in the case of the fuel cell, a use for low temperature heat), for heating or hot water in a mixed use facility, the paybacks for all systems would be reduced. For comparison purposes, the paybacks for each system with full utilization of thermal energy for heating, no cooling, are the lowest of all of the options. In a mixed use facility, the

Table 15: CHP Paybacks for Alternative Facility Configurations

Alternative CHP/Facility Configurations (Payback, years)	1000 kW IT Case 1	1000 kW IT Case 2	1000 kW IT Case 3	10,000 kW IT Case 4
Best Practices Facility (Table 14) – 28% free cooling, no hot water demand on-site	6.1	11.5	11.1	3.4
Facility without free cooling – Full cooling utilization, no hot water demand on-site	5.8	8.9	11.1	3.3
Best Practices/mixed use – 28% free cooling, thermal energy use 100%, excess thermal energy supplies hot water needs when not needed for cooling	4.8	6.6	6.5	2.8
Mixed Use CHP -- 100% thermal use for hot water only, no cooling load	2.9	4.1	4.9	2.3

economics of CHP may be improved by utilizing the heat energy for heating and/or hot water applications first.

As previously noted, the average power price used for the economic analysis is consistent with high priced markets in the Northeast and in California. **Figure 12** shows the sensitivity of CHP paybacks for the mixed use with free cooling case (free cooling, full utilization of CHP heat) for various retail electric rates, at the \$7.50/MMBtu gas price used in the analysis shown.. The sensitivity analysis shows that based on energy savings alone, the systems are only competitive at the high end of electric prices. At the average U.S. industrial electric price of 6.27 cents/kWh and current gas prices, smaller CHP systems are not competitive in these cooling dominated applications.

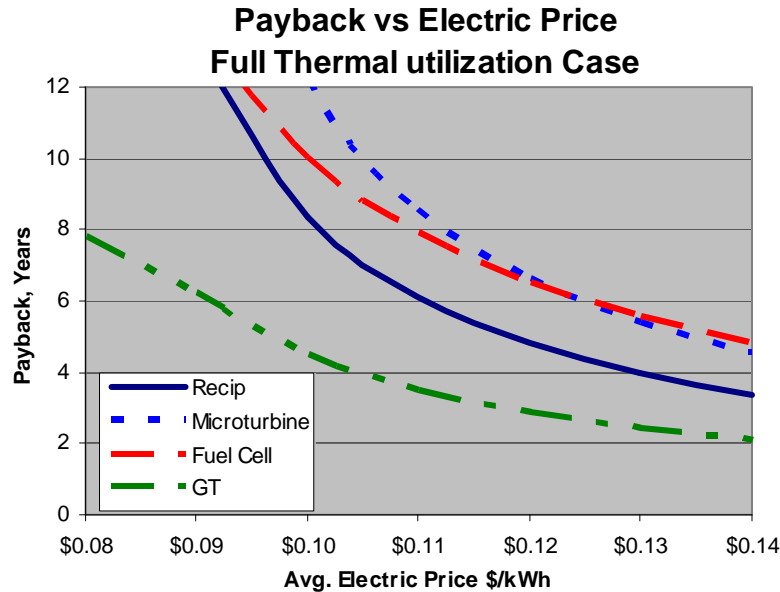

Figure 12: Sensitivity of Payback to Average Electric Rate

Primary Energy and GHG Comparison

The energy and greenhouse gas (GHG) emissions impacts of improving data center operation and using CHP are described in this section. CHP uses primary energy resources more efficiently than purchasing power from the utility grid as shown in **Figure 13**. When power is produced remotely from the point of use, over two-thirds of the primary energy used for power generation is wasted. Then, additional energy is wasted in transmitting the power over the transmission and distribution lines to the point of end-use. When power is produced on-site, the waste heat from power production can be converted to cooling, which replaces additional power consumption at the site. In addition, there are no line losses associated with on-site power production.

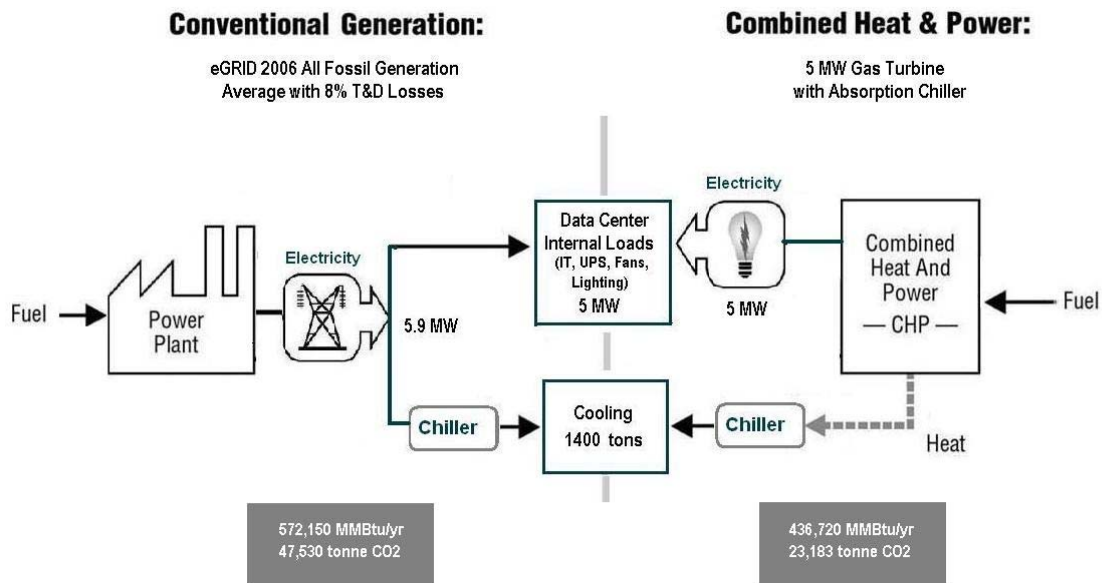

Figure 13: Schematic of CHP Efficiency and GHG Emissions Benefits for 5 MW of Core Load

To accurately measure the impact of electric energy consumption for data centers, the delivered electricity must be valued on a primary energy basis – the quantity of energy required to generate enough electricity to deliver a kWh to the customer. This measure includes both the efficiency of power generation itself and the line losses associated with electricity transmission and distribution. For this analysis, the primary energy required to deliver a kWh of electricity has been taken from EIA.³¹ For 2008, the primary energy required is 10,760 Btu/kWh indicating that electricity is produced and transmitted to final customers at an average efficiency of 31.7%. In the EIA forecast, the primary energy value declines slowly to 10,195 by 2030 or an average supply efficiency of 33.5%.

³¹ *Annual Energy Outlook 2007*, (Reference Case), Energy Information Administration.

The GHG emissions associated with power generation depends on both the region and the basis of the estimate. The average emissions are not as relevant for comparing the benefits of CHP as are the marginal GHG emissions. The climate trust has prepared estimates of the marginal impact of reducing electricity consumption in each U.S. NERC subregion.³² The marginal grid GHG intensity factors are shown in **Table 16** (Map, **Figure 14.**) For this analysis a simple average of all of the subregion values was used – 0.619 MT/MWh.

Using the primary energy and GHG emissions factors described above, the nominal 1,000 kW and 10,000 kW case results are shown in and **Tables 17** and **18**.

The benefits of the nominal 1,000 kW case are shown graphically in **Figure 15** and **Figure 16**. There is a 67.7% reduction in energy and emissions when going from data center typical practice to a “best-practices” case that includes a 50% reduction in the IT equipment electric energy for a given IT capability, improvement in the efficiency of the electric power supply and UPS, and an efficient chilled water cooling system. CHP, when applied to the best practices facility can provide an additional 4-16% reduction in primary energy use and a 8-20% reduction in GHG emissions. **Figure 17** shows the GHG impact of the nominal 10,000 kW IT case. The difference between the typical and best-practices case is the same as before. The additional benefit of CHP applied to the best-practices facility is a 17% reduction in GHG emissions.

³² Climate Trust, 2007 RFP Electricity Baselines,
http://www.climatetrust.org/solicitations_2007_Electricity.php

Table 16: U.S. Combined Marginal Grid GHG Intensity Factors

Subregions	Grid Intensity Factors
(eGrid subregion names in parentheses)	(metric tons CO ₂ /MWh)
AKGD (ASCC Miscellaneous)	0.543
AKMS (ASCC Alaska Grid)	0.529
CALI (WECC California)	0.493
ECMI (ECAR Michigan)	0.627
ECOV (ECAR Ohio Valley)	0.668
ERCT (ERCOT All)	0.548
FRCC (FRCC All)	0.538
HIMS (HICC Miscellaneous)	0.677
HIOA (HICC Oahu)	0.589
MACC (MACC All)	0.617
MANN (MAIN North)	0.718
MANS (MAIN South)	0.694
MAPP (MAPP All)	0.72
NEWE (NPCC New England)	0.545
NWGB (WECC Great Basin)	0.662
NWPN (WECC Pacific Northwest)	0.6
NYCW (NPCC NYC/Westchester)	0.567
NYLI (NPCC Long Island)	0.573
NYUP (NPCC Upstate NY)	0.559
ROCK (WECC Rockies)	0.672
SPNO (SPP North)	0.724
SPSO (SPP South)	0.648
SRMV (SERC Mississippi Valley)	0.595
SRSO (SERC South)	0.658
SRTV (SERC Tennessee Valley)	0.674
SRVC (SERC Virginia/Carolina)	0.631
WSSW (WECC Southwest)	0.645
Simple Average of Regions	0.619

Map of U.S. Grid Subregions

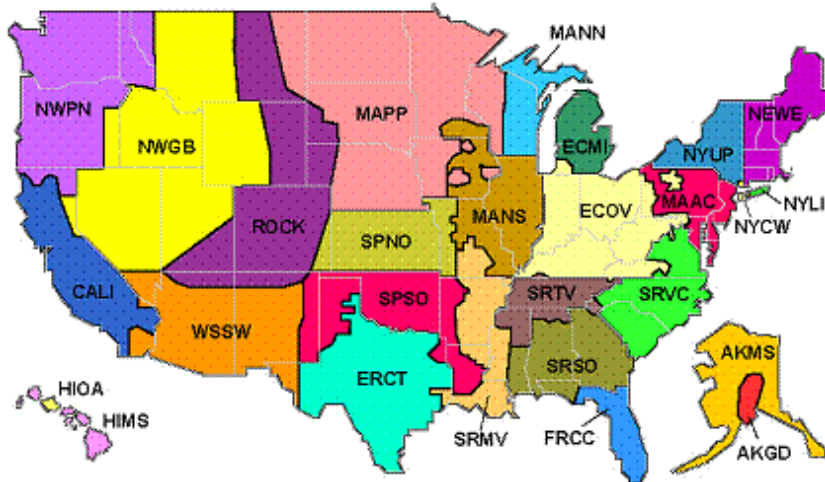

This map is of the NERC (National Energy Reliability Council) subregions. Regions are also referenced by their eGRID subregion name, show in parenthesis in the chart above. This map is courtesy of the US Environmental Protection Agency's eGRID.

Figure 14: NERC Subregions

Table17: Energy and GHG Emissions for Nominal 1,000 kW Efficient IT Case Analysis

Nominal 1,000 kW Efficient IT Case Analysis			Case 1	Case 2	Case 3
	Typical	Best Practice	Best Practice + Recip CHP	Best Practice + MT CHP	Best Practice + FC CHP
Facility Core Electric Load, kW	3,564	1,352	1,352	1,352	1,352
Facility Cooling Load, kW	1,115	218	218	218	218
Total Electric Capacity, kW	4,679	1,570	1,570	1,570	1,570
CHP Capacity, kW	n.a.	n.a.	1,060	752	1,200
Building Cooling Load, tons	1,013	364	364	364	364
CHP Cooling Capacity, tons	n.a.	n.a.	266	362	150
Annual Energy Use					
Annual Core Electric Purchase, MWh	31,218	11,843	3,022	5,585	1,857
Annual Cooling Electric Purchase, MWh	9,767	1,377	187	69	627
Total Electric Purchases, MWh	40,985	13,220	3,209	5,654	2,484
Total Gas Consumption, MMBtu	0	0	85,282	76,481	94,581
Total Primary Energy Consumption, MMBtu	441,009	142,252	119,809	137,319	121,313
CO ₂ Emissions					
Source Electric, MT	25,370	8,183	1,986	3,500	1,538
Natural Gas, MT	0	0	4,527	4,060	5,021
Total CO ₂ Emissions, MT	25,370	8,183	6,513	7,560	6,559

Table 17: (continued)

Nominal 1,000 kW Efficient IT Case Analysis			Case 1	Case 2	Case 3
	Typical	Best Practice	Best Practice + Recip CHP	Best Practice + MT CHP	Best Practice + FC CHP
Energy and GHG Conversion Assumptions		Source			
2008 Source Energy for Electric Btu/kWh	10,760	EIA AEO2007			
Average of eGRID Regions MT/MWh	0.619	Climate Trust			
Natural Gas, MT/MMBtu	0.053	EPA			

Table 18: Energy and GHG Emissions for Nominal 10,000 kW Efficient IT Case Analysis

Nominal 10,000 kW Efficient IT Case Analysis	Case 1	Case 2	Case 3
	Typical	Best Practice	Best Practice + GT CHP
Facility Core Electric Load, kW	35,637	13,520	13,520
Facility Cooling Load, tons	11,149	2,183	2,183
	46,787	15,703	15,703
CHP Sizing Strategy			Thermal
CHP Capacity, kW	n.a.	n.a.	8,850
Building Cooling Load, tons	10,133	3,637	3,637
CHP Cooling Capacity, tons	n.a.	n.a.	2,606
Annual Energy Use			
Annual Core Electric Purchase, MWh	312,182	118,433	44,783
Annual Cooling Electric Purchase, MWh	97,669	13,768	1,992
Total Electric Purchases	409,851	132,201	46,775
Total Gas Consumption Million Btu	0	0	734,167
Total Primary Energy Consumption, MMBtu	4,410,088	1,422,515	1,237,473
Total CO ₂ Emissions			
Source Electric, MT	253,697	81,832	28,953
Natural Gas, MT	0	0	38,973
Total CO ₂ Emissions, MT	253,697	81,832	67,927
Energy and GHG Conversion Assumptions		Source	
2008 Source Energy for Electric Btu/kWh	10,760	EIA AEO2007	
Average of eGRID Regions MT/MWh	0.619	Climate Trust	
Natural Gas, MT/MMBtu	0.053	EPA	

Primary Energy Use for Nominal 1,000 kW IT Load

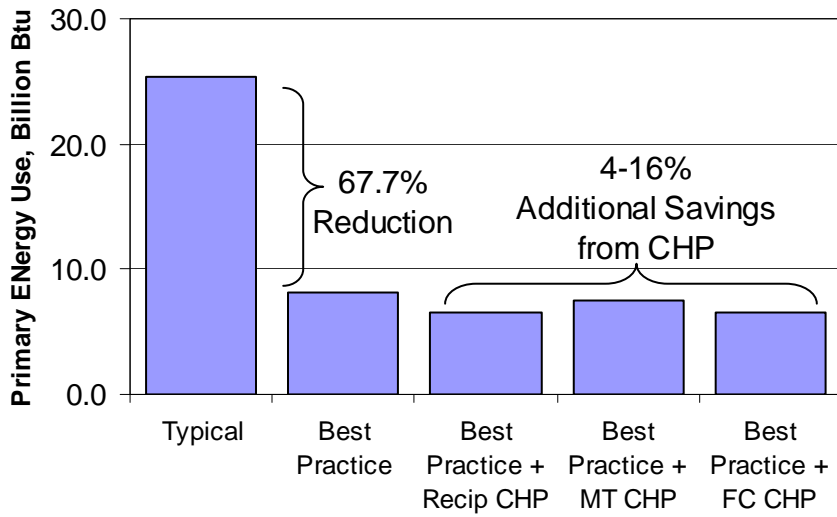

Figure 15: Comparison of Primary Energy Savings, 1,000 kW IT Case

CO2 Emissions for Nominal 1,000 kW IT Load

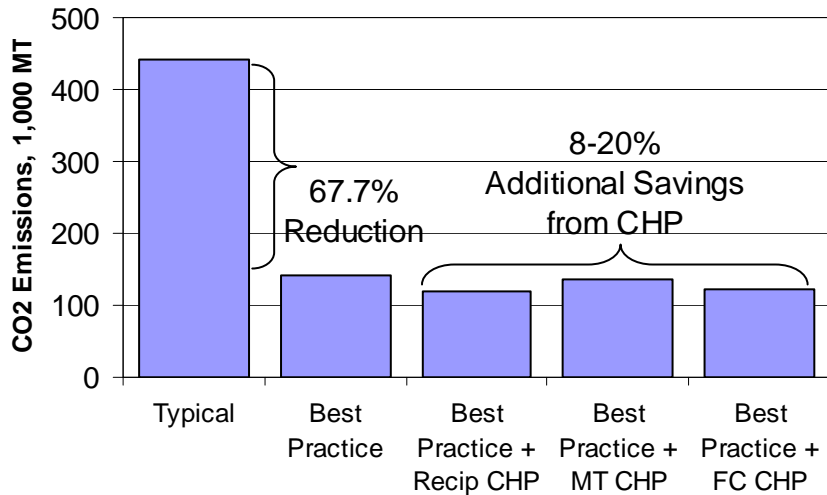

Figure 16: GHG Emissions Savings, 1,000 kW IT Case

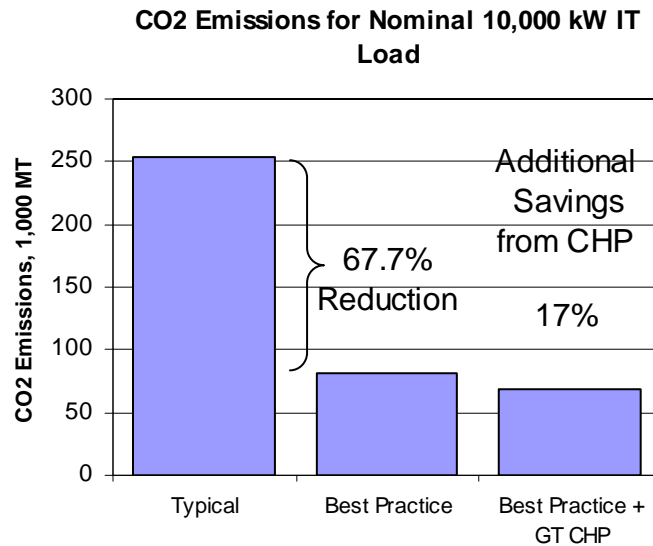

Figure 17: GHG Emissions Savings, 10,000 kW IT Case

Energy Efficiency Metric for Data Centers

The energy efficiency of data centers has been described previously as the data center infrastructure efficiency (DCIE) which measures the ratio of IT load to total data center load. The higher the ratio, the more efficient is the energy infrastructure meeting the IT load. As previously outlined, the DCIE of the typical data center in 2008 as described in this report was only 42.3%. In other words, an amount of power more than equal to the IT load itself is needed to support the IT load. In the optimized practices facility, the DCIE increased to 66.3%.

There are two limitations to DCIE:

1. There is no direct measure for how effective the IT load itself is. A data center could have a poorly designed IT system with idling and obsolete equipment drawing a significant share of the IT power, or a well designed system with virtualization and removal of obsolete equipment and shutting down equipment that is not being used, and still have the same DCIE. For this analysis, it was assumed that a well designed IT architecture could cut energy requirements in half. In fact, there are examples, through virtualization, where this improvement was even greater. The problem for energy analysis is that there is no accepted metric that differentiates between optimized IT design and poor IT design.
2. DCIE does not capture the impacts of primary energy use and resulting GHG emissions. This is a critical factor in evaluating the benefits of CHP and other distributed generation technologies such as solar PV. CHP can produce reductions in

both primary energy use and GHG emissions, even though energy use at the facility may increase.

While, there is no immediate solution to the first issue, the value of CHP or other technologies such as PV that replace purchased power can be recognized by a measure that can be called Primary Energy DCIE. The Primary Energy DCIE is equal to the IT load in delivered kWh divided by the primary energy required by the facility to meet that load. For the examples presented in this section the Primary Energy DCIE is shown in **Table 19**. This measure captures the benefits of the reduction in primary energy requirements offered by CHP.

Table 19: Primary Energy DCIE

Primary Energy DCIE (Delivered IT Energy Btu/ Total Primary Energy Btu)	Typical	Best Practice	Best Practices + CHP
1,000 kW Nominal IT Load (FC CHP)	13.6%	21.0%	28.9%
10,000 kW Nominal IT Load (GT CHP)	13.6%	21.0%	27.8%

Examples of CHP Systems in Data Centers and Facilities with Data Processing Loads

Distributed generation has been successfully employed in data centers using a variety of prime movers. While not yet a widespread practice, CHP has been employed in a number of commercial CHP installations in dedicated data centers or in office buildings, banks and communications facilities where data processing is a major activity within the building. **Table 20** shows a range of examples. A variety of technologies have been used successfully, including fuel cells, reciprocating engines, gas turbines and microturbines.

Following are brief case studies highlighting three recent CHP installations:

Example Fuel Cell Application

In April 2002, Verizon Communications was awarded a DOE grant through a program aimed at supporting distributed energy resources in applications for data processing and telecommunications. As part of its Central Office of the Future Project, Verizon installed multiple fuel cells and reciprocating engine generators to power a large central communications and data facility in New York. Verizon installed seven 200 kW fuel cells to provide 1.4 MW of power for a large central communications and data facility in New York. Absorption Chillers were installed to use the waste heat from the 7 fuel cells to provide cooling to the site as well. DOE and NYSERDA provided funding for the project to gain a better understanding of the kind of controls that are needed for multiple DG units and how low-grade heat for CHP benefits the system’s overall efficiency.

Verizon’s Garden City project is unique because it uses fuel cells as its primary source of energy. Seven fuel cells generate power for the 292,000-square-foot facility that provides

Table 20: CHP Installations in Data Center and Communications Facilities

Facility Name	City	State	Prime Mover	Capacity (kW)	Op Year
Telecommunications Facility	Burlingame	CA	Microturbine	120	2003
Chevron Accounting Center	Concord	CA	Recip Engine	3,000	1988
Guaranty Savings Building	Fresno	CA	Fuel Cell	600	2004
Citibank West FSB Building	La Jolla	CA	Microturbine	60	2005
QUALCOMM, Inc.	San Diego	CA	Gas Turbine	11,450	1983/2006
WesCorp Federal Credit Union	San Dimas	CA	Microturbine	120	2003
ChevronTexaco Corporate Data Center	San Ramon	CA	Fuel Cell	200	2002
Network Appliance Data Center	Sunnyvale	CA	Recip Engine	825	2004
Flint Energies Service Center Facility	Warner Robins	GA	Fuel Cell	5	2002
Zoot Enterprises	Bozeman	MT	Recip Engine	500	2003
First National Bank of Omaha	Omaha	NE	Fuel Cell	800	1999
AT&T	Basking Ridge	NJ	Recip Engine	2,400	1995
Continental Insurance Data Center	Neptune	NJ	Recip Engine	450	1995
Verizon Communications	Garden City	NY	Fuel Cell	1,400	2005
Verizon	Ontario	CA	Microturbine	360	2007
Verizon	Pomona	CA	Microturbine	360	2007
Undisclosed End User	Undisclosed	NJ	Microturbine	840	2008
Computer Sciences Corporation	Newington	CT	Microturbine	1,170	2009

Source: ICF International and UTC Power

telephone and data services to some 35,000 customers on Long Island. Operating reliably since 2005, the CHP system meets almost 80% of the facility power load, 75% of its heating load, and one-third of its cooling load. The center is only connected to the commercial power grid as a power backup.

Verizon’s benefits from the system are:

- \$680,000 per year in operating cost savings
- An expectation of higher facility reliability and reduced costs due to power outages
- Displacement of one-third of its electric air conditioning load to thermally activated cooling powered by the waste heat of the fuel cell power systems.
- Lower emissions than that produced by central power plant. The facility eliminates 11 million pounds per year of CO₂ that would have been produced by a fossil-fueled central station power plant.
- Higher overall efficiency.

These benefits were tempered somewhat by the cost of the fuel cells at the time of installation. A number of incentives from DOE and DOD helped to offset the initial cost. Also, the model used will be supplanted by a redesigned, larger model and costs are much lower and more competitive.

Example Gas Turbine Application

Qualcomm, a manufacturer and supplier of IT and communications equipment, has made numerous energy saving investments at its office/data center world headquarters in San Diego, California, including lighting retrofits, HVAC upgrades, and improvements to the building envelope; installation of a 500 kW solar photovoltaic system; use of hybrid vehicles for corporate shuttle service; incorporation of efficient CHP to provide power, cooling and hot water to their facility. The company owns and operates two CHP facilities in San Diego, California.

Qualcomm has maintained and operated its “P” CHP plant since 1995. The “P” CHP plant supports a campus of more than 2 million square feet, which includes Qualcomm’s corporate headquarters, lecture hall, cafeteria, medical center, engineering and research offices, labs, data center, network operations center, satellite communications hub, prototype manufacturing, and three parking structures. In 1995, Qualcomm installed a 2.4 megawatt (MW) gas turbine CHP system, consisting of three 800 kilowatt (kW) Solar Turbine Saturn generators. The 800 kW turbines run on natural gas, but can be switched to run on jet fuel if the natural gas supply is interrupted. The waste heat from the turbines is sent to a heat recovery unit producing hot water used to power absorption chillers. Based on a positive experience with the original gas turbine system, Qualcomm increased its reliance on CHP when it initiated a campus expansion in 2005. As part of the expansion, Qualcomm added a 4.5 MW Solar Mercury 50 gas turbine and a Broad 1,400 ton absorption chiller driven directly by turbine exhaust gas to help support growing site power and cooling requirements. The “P” campus CHP plant results in annual operating cost savings of \$500,000. An additional \$100,000 is saved annually through a heat recovery unit that supplies hot water to the facility. Onsite power generation also reduces demand for utility electricity by over 14 million kilowatt-hours (kWh) per year, saving another \$122,000. Total annual savings achieved by the CHP system have been as high as \$775,000.

In 2007, Qualcomm installed a second CHP system, known as the “W” CHP plant, to support a new 1 million square foot campus consisting of another data center, engineering offices, labs, a chip test floor, a cafeteria, and a parking structure. This Leadership in Environmental and Energy Design (LEED) Gold-certified campus requires 8 MW of electricity, with 4 MW classified as critical load to support the 12,000 square foot data center. The CHP system consists of a second Solar Mercury 50 gas turbine with a waste heat recovery boiler. The system provides up to 4.5 MW of power for the building, recovering high temperature water from the turbine exhaust to drive a 1,200 ton Trane absorption chiller that provides cooling for the data center and building. The CHP system supplies approximately 85 percent of the building’s power and cooling loads, resulting in significant carbon dioxide (CO₂) and nitrogen oxide (NO_x) emissions reductions.

Qualcomm estimates that their CHP systems reduce overall carbon emissions by 12 percent and NO_x emissions by 91 percent on an annual basis. The combined energy savings from the “P” CHP plant expansion and the “W” CHP plant result in an estimated payback period of four years.

CHP Market Drivers and Hurdles

CHP systems benefits data center operators in the form of reduced costs of operation and increased reliability of power supply. In addition, CHP provides benefits of increased efficiency, reduced source emissions of criteria pollutants, and reduced emissions of GHGs. These external benefits can be, at least partially captured, by the data center operators in the form of incentive payments and a more positive corporate profile.

CHP Market Drivers for Data Centers

- High electricity costs in the Northeast and California as well as certain other major markets in the U.S. provide an opportunity to save on energy costs using CHP to provide base load power and using the heat from the prime mover to provide absorption cooling for the facility. In these markets, savings are enough to provide attractive economic paybacks on the initial CHP investment.
- CHP can provide user cost savings in regions where average electric rates are more than 10 cents/kWh. Larger facilities can take advantage of more cost effective larger CHP systems.
- Power constraints at some existing facilities are stimulating the industry to look at CHP as a way to be able to expand or even continue to operate existing facilities.
- A well designed CHP system can strengthen the power reliability at a data center by providing another source of power supply.
- A CHP system provides an economic development value by reducing the energy costs of operating facilities so that more resources can be devoted to IT capability rather than paying high energy bills. “Stranded” assets in high cost power markets can be made more economic through CHP.
- Federal investment tax credits are available for CHP with additional credits available for microturbines and fuel cell systems.
- There are active demonstration and grant programs that will provide financial support for developing a CHP system. These include cooling technology/CHP integration demonstration, grants to relieve transmission and distribution constraints, technology stimulation for fuel cells and other technologies, carbon credits and other green programs.
- CHP systems reduce the GHG emissions for data centers by 8-20%. Even without specific programs to provide incentives for reducing GHGs, major internet companies have “green” corporate mission statements and are looking for sustainable options, showcase projects, and high LEED® (US Green Building Council's Leadership in Energy and Environmental Design) ratings.
- Fuel Cells followed by microturbines and gas turbines also greatly reduce criteria pollutants. Additionally, PAFC fuel cell technology and microturbines conserve water relative to the grid based power. These technologies comply with one of the strictest

emissions standard in the world set forth by the California Air Resources Board (CARB).

- Increasing CHP will preferentially accelerate the retirement of older, less efficient, less environmentally friendly power plants. Therefore, the comparison to the average fossil-based power plant emissions is more meaningful than the comparison to the state-of-the-art gas-fired combined cycle plant.
- There are manufacturers and developers that are promoting CHP/cooling solutions for data centers. Because of their very high electricity consumption, data centers have high power costs. Installation of CHP systems with absorption cooling can often reduce energy costs by producing power more economically on site than can be purchased from the utility supplier. In addition, waste heat from the power generation can drive absorption chillers that displace electric air conditioning loads.
- An emerging trend from some IT suppliers is the “data center in a box” with all equipment provided and standardized. CHP could be designed as a part of a “plug and play” package.

Barriers to CHP Implementation in Data Centers

- Some data center IT equipment has an economic life of only 2-3 years. CHP equipment has a life of 10-20 years. Operators are not certain about what their facility needs will be 5 years from now so may be reluctant to commit to CHP.
- Initial facility load estimates are almost always over-estimated. Also facilities often start out at low loads and grow into the site gradually. CHP design must be based on realistic load estimation and also provide a modular solution for future growth.
- The trend toward larger enterprise class data centers with projected loads of up to 50 MW means that companies try to locate their facilities in areas that provide them the most tax breaks and the lowest energy costs, i.e., they will often try to locate outside of the primary CHP markets because those markets have electric costs that are too high.
- Experience in the field has shown that a properly designed and maintained CHP system can provide benefits in terms of enhancing power reliability for the facility. However, the redundancy requirements for Tier III and Tier IV facilities make it difficult to “monetize” these benefits. Additionally, gas-fired CHP, because the fuel supply is not located on-site, is not currently recognized as an independent form of back-up for these applications.
- IT management is responsible for the IT design and facility management is responsible for the mechanical and electric systems that must support the IT loads. There is often not sufficient communication between those entities that would allow facilities people the time to develop optimized solutions. This is also true in the federal sector where FEMP is responsible for providing energy efficiency in buildings, but is generally completely removed from the IT decision-making of the “tenant” agency.

- The cost of downtime is so high for data centers that any risk of outages, either perceived or real, is strongly avoided. If CHP is viewed as adding complexity and risk it would be avoided. Many facility operators are reluctant to deviate from the standard design of UPS, battery storage, and standby diesel generators. The failure modes of these systems are well known, and proper design to ensure reliability is reduced to standard practice.
- Mechanical systems in data centers are so critical and complicated that the industry relies on HVAC engineering and design firms with a proven track record. Often these firms will not specify equipment that they have not successfully used before or are unfamiliar with such as CHP and absorption chillers.
- There are a limited number of examples of CHP in dedicated data centers requiring ultra-high reliability. This means that all failure modes are not completely known, specifically the interaction of the fuel cell or microturbine system power electronics with the UPS and switching systems. There have been limited demonstration systems as described earlier, and these systems are important in proving reliability and improving operational practices.
- Fuel price volatility increases the perceived economic risk for data centers (or any user). There are examples of CHP systems running limited hours because fuel prices increased beyond expectations.
- Power outage costs are so high that many facility operators are reluctant to deviate from the standard design of UPS, battery storage, and standby diesel generators. The failure modes of these systems are well known, and proper design to ensure reliability is reduced to standard practice.
- Low production levels for small prime mover technologies and custom designed packaging for CHP systems contribute to high capital costs. There is a need for both higher production levels and also engineering and materials advances to bring costs down. Improvements in packaging, site engineering, and installation costs are needed to make CHP more widely economic.
- CHP installations require significant capital investment particularly in topologies that are fault tolerant and concurrently maintainable. Most segments of the data center industry are capital limited and have very short planning horizons.
- Part of the value of CHP is the integration of thermally activated cooling. Data centers have large cooling needs, but they use very specialized equipment. Demonstration of the reliable operation of absorption cooling and effective operation of back up cooling systems is needed to educate both facility operators and HVAC design and engineering firms specializing in the data center industry.

CHP Paths to Market

There is an emerging market for the use of CHP in data centers. As previously noted, there are manufacturers and developers that are designing systems specifically for data centers.

There are major companies such as Qualcomm and Verizon that are gaining experience with CHP.

Much of the early success has been in mixed applications of data center loads combined with loads that are part of the same building that houses the data center or an adjoining facility. Cooling only CHP is economic in some applications and high electric cost regions, but the payback of systems is improved if all or a part of the thermal energy can be used directly as heat. Therefore, data centers integrated with other applications that could utilize waste heat make attractive CHP targets because they have the 24/7 load component and can provide more savings than a system with thermal cooling alone. This is especially true for the PAFC fuel cell which can only use half of its thermal energy in a cooling only application.

Optimizing IT design and the efficiency of the energy infrastructure to data centers can save 2/3rds of the energy requirements for the same IT capability. Much of this improvement can be available at a low cost for the next generation of data centers and even existing facilities can benefit. CHP can provide an additional 8-20% reduction in GHG emissions; however, the cost of CHP makes it economically beneficial only in high electric cost regions of the country.

Market forces alone do not provide the appropriate incentive for either users to adopt CHP or developers and manufacturers to rapidly develop more efficient and less costly systems. Therefore, without government intervention, there will be underinvestment in CHP technology because the social benefits of energy efficiency, grid reliability, resource adequacy, and reduction in emissions of greenhouse gases are not captured in the private decision-making process.

Appropriate market stimulation should include such activities as:

- Continue evaluation and education on data center benchmarking and best practices. In addition to directly benefiting the data center industry, CHP designers and developers will see the market opportunity and benefit from a better understanding of the market requirements.
- Develop data center CHP best practices guide to provide operators and design firms with an understanding for appropriate electrical and mechanical designs and operating principles for onsite generators, absorption chillers, and integration of PV.
- Emerging trends for state level incentives for reducing T&D constraints, reducing GHG emissions, supporting energy efficiency will support additional CHP development as it has in California and more recently in Connecticut. Analysis of these benefits of CHP will provide an information base for policy decisions.
- Continued RD&D on distributed generation will improve efficiencies, lower emissions, and reduce capital and operating costs. A federal role in this activity is justified by the social benefits of CHP that are not currently captured in the private market.
- In addition, support thermally activated cooling RD&D including integration with CHP and applications.

- Support longer term RD&D in fundamentally redesign of data center operations including direct liquid cooling and direct DC power distribution to the IT load. Both of these changes would further improve the DCIE (data center infrastructure efficiency.) Additional work on integration of these changes with CHP would provide synergies, particularly with fuel cells and microturbines that could eliminate the inverter from their power electronics package.

Conclusions

The targets for CHP are in the 13,000 to 19,000 stand alone datacenter facilities. Further, the largest 1,000 to 2,000 Enterprise Class facilities potentially represent very attractive opportunities due to the large concentrated power loads.

The historical locations of data center facilities are concentrated in a number of states: California, a strong CHP market, is by far the largest market followed by Texas, Florida, and New York. Other states in the top 20 that are also strong CHP target markets are Massachusetts, New Jersey, and Pennsylvania. Large internet and other data intensive corporations have somewhat more freedom to locate in low cost markets, but CHP may still be attractive for keeping existing facilities viable in high power cost states.

A ten year load growth in data center power requirements has been estimated at 6,500 MW making it an attractive market for CHP developers.

Data centers are fairly homogeneous in terms of their load factor and power to cooling requirements. It is possible to develop customized CHP systems for data centers. Currently there are manufacturers and developers that are actively developing data center specific designs, such as UTC and Turbine Air Systems. The CHP system sees a nearly constant power and cooling load. The cooling needed is in the ratio of 0.28 tons/kWh delivered to the interior space.

The reliability of the data center power and chiller systems is of utmost importance, so any CHP application must be appropriately integrated with redundant power supplies (grid, standby generators, UPS) and with back-up electric cooling systems.

With current CHP system costs and performance, economic paybacks can be achieved in high cost electric regions – basically California and the Northeast with other market opportunities in Texas, Illinois, and parts of the Southwest.

There are a range of CHP technologies that are suitable for data centers. CHP systems are available in sizes down to 30 kW, but integration with thermally activated cooling make 500 kW a more economic minimum. Applicable systems would be based on recip engines, microturbines and fuel cells. Gas turbine CHP systems are suitable for larger facilities, including the largest announced data center projects of up to 50 MW for a single facility.

Many of the benefits of CHP are societal in nature – increased efficiency of energy resources, reduced GHG emissions, reduced criteria pollutants, economic development, and grid reliability – and are not currently monetized nor accrue to the user. Therefore, federal and state programs addressing education, incentives, and RD&D are warranted to stimulate CHP

development and market introduction. These programs serve to add the value of societal benefits back into the private developer's decision making.

