

# Optics

*The basic purpose of a lens of any kind is to collect the light scattered by an object and recreate an image of the object on a light-sensitive 'sensor' (usually CCD or CMOS based). A certain number of parameters must be considered when choosing optics, depending on the area that must be imaged (field of view), the thickness of the object or features of interest (depth of field), the lens to object distance (working distance), the intensity of light, the optics type (telecentric/entocentric/pericentric), etc.*

*The following list includes the fundamental parameters that must be evaluated in optics*

- **Field of View (FoV):** total area that can be viewed by the lens and imaged onto the camera sensor.
- **Working distance (WD):** object to lens distance where the image is at its sharpest focus.
- **Depth of Field (DoF):** maximum range where the object appears to be in acceptable focus.
- **Sensor size:** size of the camera sensor's active area. This can be easily calculated by multiplying the pixel size by the sensor resolution (number of active pixels in the x and y direction).
- **Magnification:** ratio between sensor size and FoV.
- **Resolution:** minimum distance between two points that can still be distinguished as separate points. Resolution is a complex parameter, which depends primarily on the lens and camera resolution.



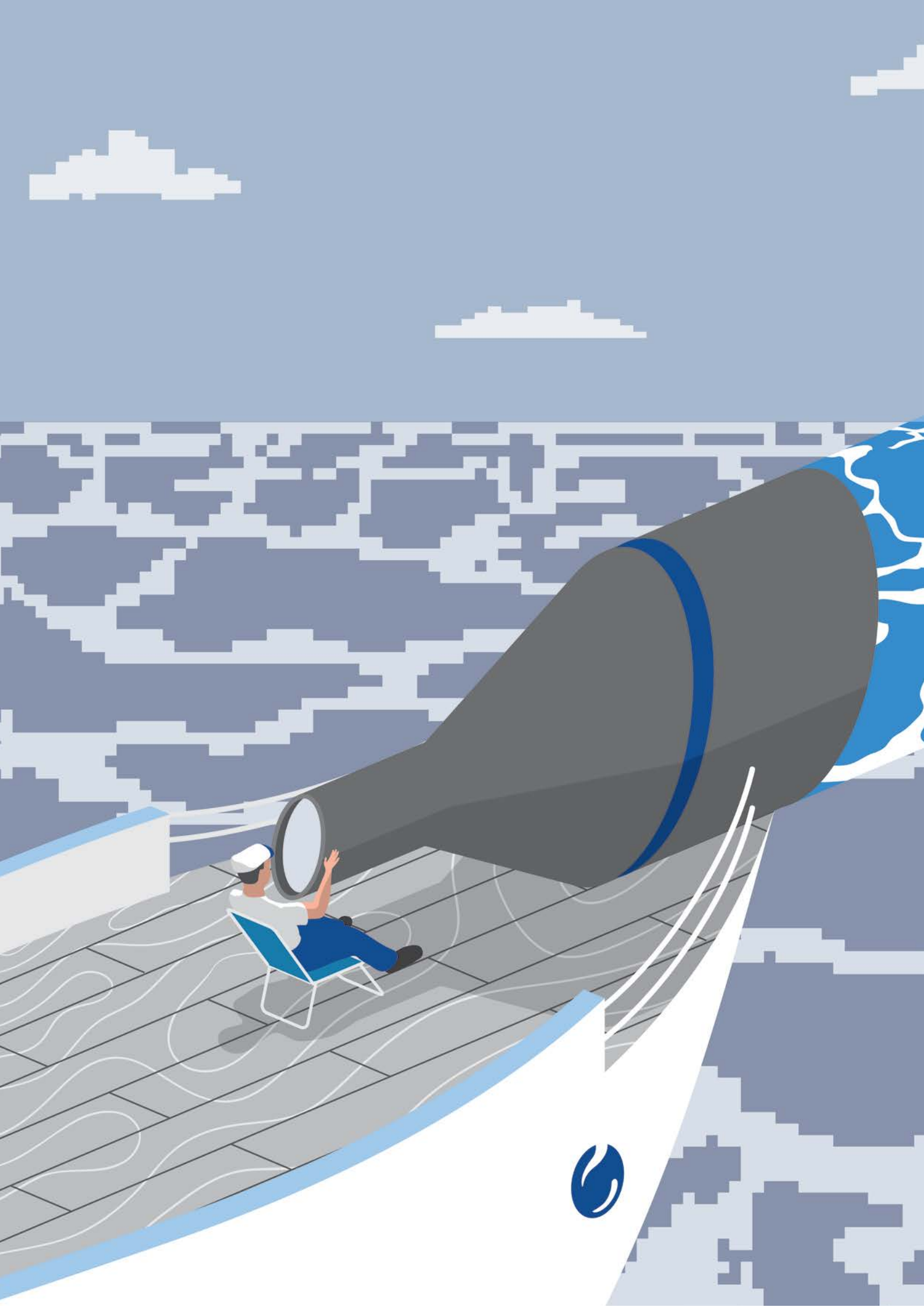

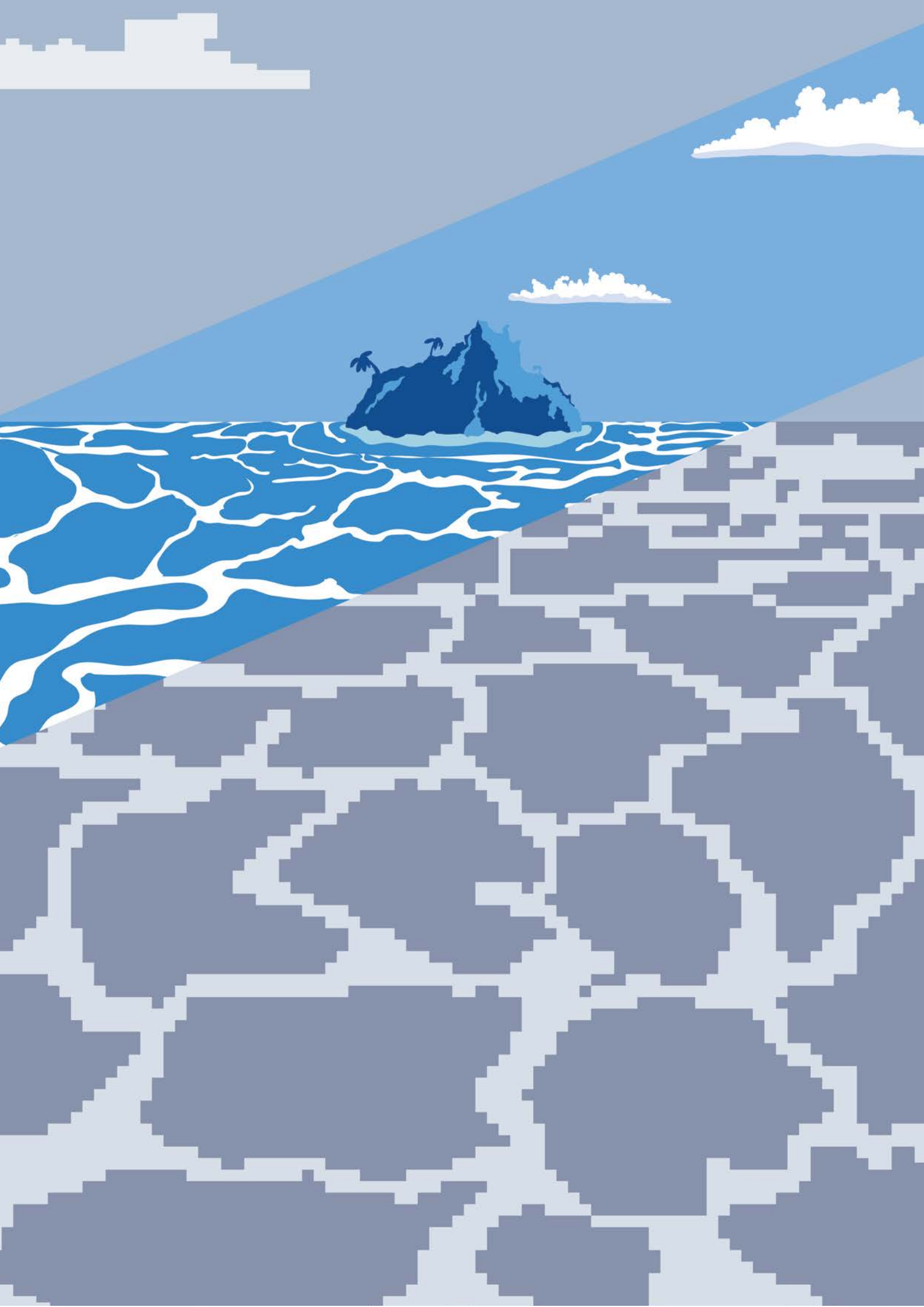



## Optics basics

### Lens approximations and equations

The main features of most optical systems can be calculated with a few parameters, provided that some approximation is accepted. The paraxial approximation requires that only rays entering the optical system at small angles with respect to the optical axis are taken into account. The thin lens approximation requires the lens thickness to be considerably smaller than the radii of curvature of the lens surfaces: it is thus possible to ignore optical effects due to the real thickness of the lenses and to simplify ray tracing calculations. Furthermore, assuming that both object and image space are in the same medium (e.g. air), we get the fundamental equation:

$$1/s' - 1/s = 1/f$$

where  $s$  ( $s'$ ) is the object (image) position with respect to the lens, customarily designated by a negative (positive) value, and  $f$  is the focal length of the optical system (cf. Fig. 1). The distance from the object to the front lens is called working distance, while the distance from the rear lens to the sensor is called back focal distance. Henceforth, we will be presenting some useful concepts and formulas based on this simplified model, unless otherwise stated.

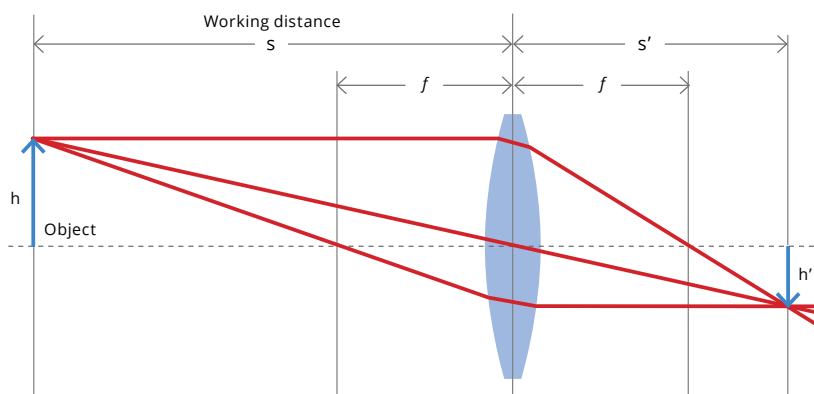

Fig. 1: Basic parameters of an optical system.

### Camera mounts

Different mechanical mounting systems are used to connect a lens to a camera, ensuring both good focus and image stability. The mount is defined by the mechanical depth of the mechanics (flange focal distance), along with its diameter and thread pitch (if present). It's important that the lens flange focal distance and the camera mount flange distance are exactly the same, or focusing issues may arise. The presence of a threaded mechanism allows some adjustment to the back focal distance, if needed. For example, in the Opto Engineering® PCHI series lenses, the backfocal adjustment is needed to adjust the focus for a different field of view.

**C-mount** is the most common optics mount in the industrial market. It is defined by a flange focal distance of 17.526 mm, a diameter of 1" (25.4 mm) with 32 threads per inch.

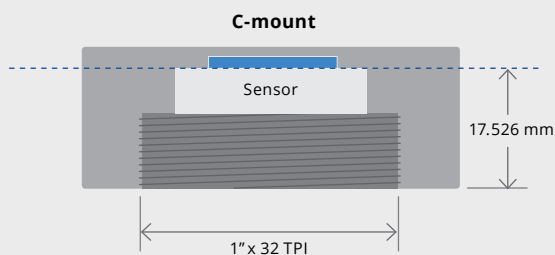

Fig. 2: C-mount mechanical layout

**CS-mount** is a less popular and 5 mm shorter version of the C-mount, with a flange focal distance of 12.526 mm. A CS-mount camera presents various issues when used together with C-mount optics, especially if the latter is designed to work at a precise back focal distance.

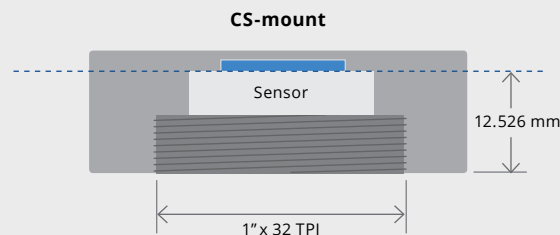

Fig. 3: CS-mount mechanical layout



**F-mount** is a bayonet-style mount originally developed by Nikon for its 35 mm format cameras, and is still found in most of its digital SLR cameras. It is commonly used with bigger sensors, e.g. full-frame or line-scan cameras. Lenses can be easily swapped out thanks to the bayonet mount, but no back focal adjustment is possible.

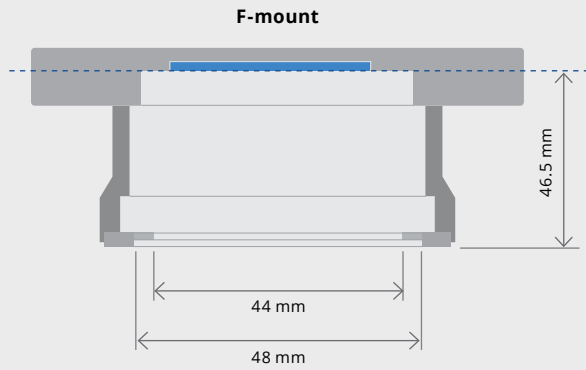

Fig. 4: F-mount mechanical layout

**Mxx-mount** are different types of camera mounts defined by their diameter (e.g. M72, M42), thread pitch (e.g. 1 mm, 0.75 mm) and flange focal distance. They are a common alternative to the F-mount for larger sensors.

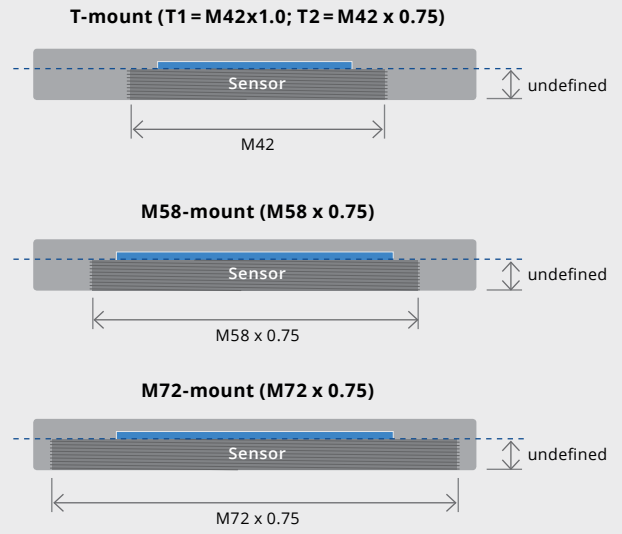

Fig. 5: Mxx mount mechanical layouts

Each camera mount is more commonly used with certain camera sensor formats. The most typical sensor formats are listed below. It is important to remember that these are not absolute values – i.e. two cameras listed with the same sensor format may differ substantially from one another in terms of aspect ratio (even if they have the same sensor diagonal). For example, the Sony Pregius IMX250 sensor is listed as 2/3" and has an active area of 8.45 mm x 7.07 mm. The CMOSIS CMV2000 sensor is also listed as 2/3" format but has an active area of 11.26 mm x 5.98 mm.

2048 px x 10 μm	2048 px x 14 μm	4096 px x 7 μm	4096 px x 10 μm	7450 px x 4.7 μm	6144 px x 7 μm	8192 px x 7 μm	12288 px x 5 μm
20.5 mm	28.6 mm	28.6 mm	35 mm	41 mm	43 mm	57.3 mm	62 mm

Fig. 6: Common line scan sensors formats

Sensor type	Diagonal (mm)	Width (mm)	Height (mm)
1/3"	6.000	4.800	3.600
1/2.5"	7.182	5.760	4.290
1/2"	8.000	6.400	4.800
1/1.8"	8.933	7.176	5.319
2/3"	11.000	8.800	6.600
1"	16.000	12.800	9.600
4/3"	22.500	18.800	13.500
Full frame - 35 mm	43.300	36.000	24.000

Fig. 7: Common area scan sensors format

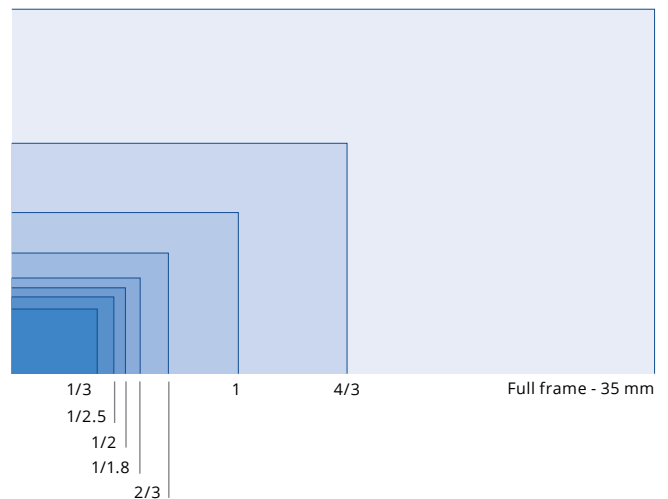

Fig. 8: Area scan sensors relative sizes



## Back focal length adjustment

Many cameras are found not to respect the industrial standard for C-mount (17.52 mm), which defines the flange-to-detector distance (flange focal length). Besides all the issues involved with mechanical inaccuracy, many manufacturers don't take into the due account the thickness of the detector's protection glass which, no matter how thin, is still part of the actual flange to detector distance.

This is why a spacer kit is supplied with Opto Engineering® telecentric lenses including instructions on how to tune the back focal length at the optimal value.

## Focal Length

The focal length of an optical system is a measure of how strongly the system converges or diverges rays of light. For common optical systems, it is the distance over which collimated rays coming from infinity converge to a point. If collimated rays converge to a physical point, the lens is said to be positive (convex), whereas if rays diverge the focus point is virtual and the lens is said to be negative (concave cf. Fig. 9). All optics used in machine vision application are overall positive, i.e. they focus incoming light onto the sensor plane.

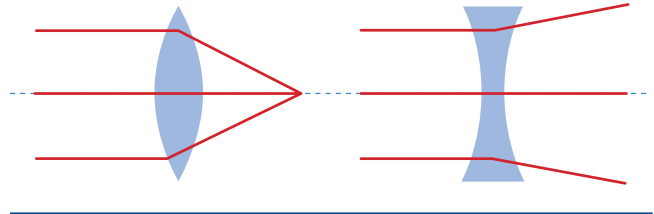
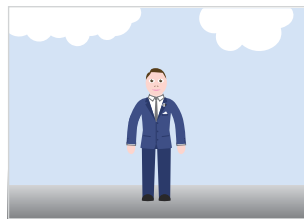
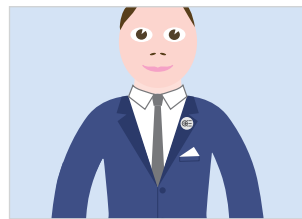

Fig. 9: Positive (left) and negative (right) lens

For optical systems used in machine vision, in which rays reflected from a faraway object are focused onto the sensor plane, the focal length can be also seen as a measure of how much area is imaged on the sensor (Field of View): the longer the focal length, the smaller the FoV and vice versa (this is not completely true for some particular optical systems, e.g. in astronomy and microscopy).



f = 8 mm



f = 25 mm



f = 50 mm

Fig. 10: Focal length and field of view

## Magnification and field of view

The magnification  $M$  of an optics describes the ratio between image ( $h'$ ) and object size ( $h$ ):

$$M = h'/h$$

A useful relationship between working distance ( $s$ ), magnification ( $M$ ) and focal length ( $f$ ) is the following:

$$s = f(M-1)/M$$

Macro and telecentric lenses are designed to work at a distance comparable to their focal length (finite conjugates), while fixed focal length lenses are designed to image objects located at a much greater distance than their focal length (infinite conjugates). It is thus convenient to classify the first group by their magnification, which makes it easier to choose the proper lens given the sensor and object size, and the latter by their focal length.

Since fixed focal length lenses also follow the previous equation, it is possible to calculate the required focal length given the magnification and working distance, or the required working distance given the sensor size, field of view and focal length, etc. (some examples are given at the end of this section). For macro and telecentric lenses instead, the working distance and magnification are typically fixed.

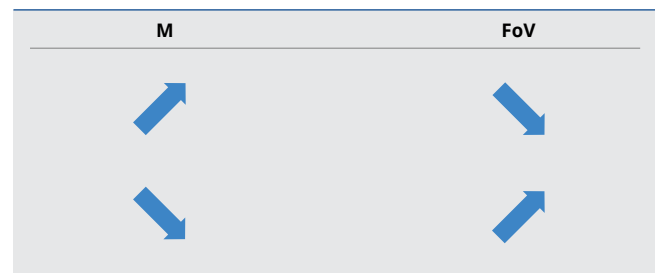

Fig. 11: Given a fixed sensor size, if magnification is increased the field of view decreases and viceversa



### F/# and depth of field

Every optical system is characterized by an aperture stop, that determines the amount of light that passes through it. For a given aperture diameter  $d$  and focal length  $f$  we can calculate the optics F-number:

$$F/\# = f / d$$

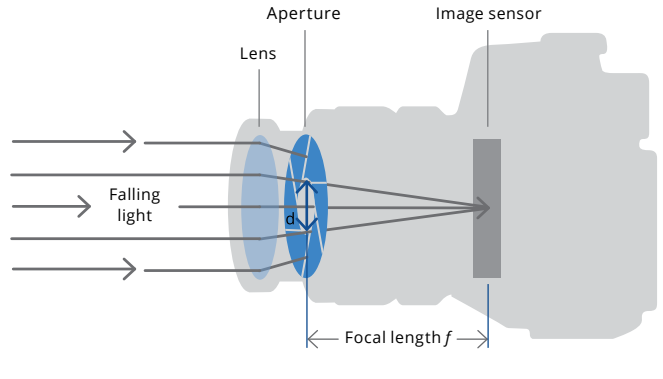

Fig. 12: Aperture of an optical system

Typical F-numbers are F/1.0, F/1.4, F/2, F/2.8, F/4, F/5.6, F/8, F/11, F/16, F/22 etc. Every increment in the F-number (smaller aperture) reduces incoming light by a factor of 2.

The given definition of F-number applies to fixed focal length lenses where the object is located 'at infinity' (i.e. a distance much greater than its focal length). For macro and telecentric lenses where objects are at closer distance, instead the working F/# (wF/#) is used. This is defined as:

$$WF/\# = (1 + M) \cdot F/\#$$

A common F-number value is F/8, since smaller apertures could give rise to diffraction limitations, while lenses with larger apertures are more affected by optical aberrations and distortion.

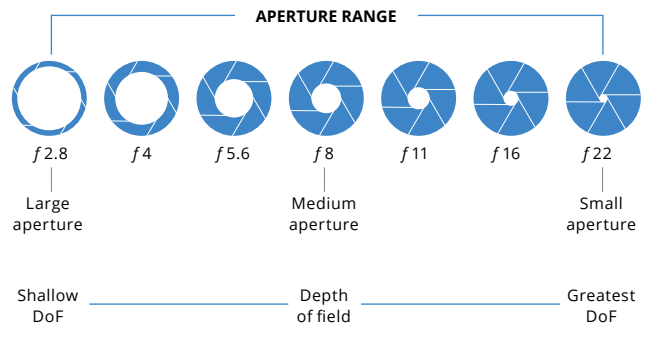

Fig. 13: Relationship between aperture (F/#) and DoF

The F-number affects the optics depth of field (DoF), that is the range between the nearest and farthest location where an object is acceptably in focus. Depth of field is quite a misleading concept, because physically there is one and only one plane in object space that is conjugate to the sensor plane. However, being mindful of diffraction, aberration and pixel size, we can define an "acceptable focusing distance" from the image conjugate plane, based on subjective criteria. For example, for a given lens, the acceptable focusing distance for a precision gauging application requiring a very sharp image is smaller than for a coarse visual inspection application.

A rough estimate of the field depth of telecentric and macro lenses (or fixed focal length lenses used in macro configuration) is given by the following formula:

$$DoF [mm] = WF/\# \cdot p [\mu m] \cdot k / M^2$$

where  $p$  is the sensor pixel size (in microns),  $M$  is the lens magnification and  $k$  is a dimensionless parameter that depends on the application (reasonable values are 0.008 for measurement applications and 0.015 for defect inspection). For example, taking  $p = 5.5 \mu m$  and  $k = 0.015$ , a lens with 0.25X mag and  $WF/\# = 8$  has an approximate dof = 10.5 mm approximated dof = 4 mm.

F/#	Incoming light	Resolution	DoF
↗	↘	↘	↗
↘	↗	↗	↘

Fig. 14: Relationship between F/# amount of incoming light, resolution and DoF





## Image quality

When designing a machine vision system, it is important to consider its performance limitations, in terms of optical parameters (FOV, DoF, resolution), aberrations, distortion and mechanical features.

### Aberrations

“Aberrations” is a general category including the principal factors that cause an optical system to perform differently than the ideal case. There are a number of factors that do not allow a lens to achieve its theoretical performance.

#### *Physical aberrations*

The homogeneity of optical materials and surfaces is the first requirement to achieve optimum focusing of light rays and proper image formation. Obviously, homogeneity of real materials has an upper limit determined by various factors

(e.g. material inclusions), some of which cannot be eliminated. Dust and dirt are external factors that certainly degrade a lens performance and should thus be avoided as much as possible.

#### *Spherical aberration*

Spherical lenses (Fig. 15) are very common because they are relatively easy to manufacture. However, the spherical shape is not ideal for perfect imaging - in fact, collimated rays entering the lens at different distances from the optical axis will converge to different points, causing an overall loss of focus. Like many optical aberrations, the blur effect increases towards the edge of the lens.

To reduce the problem, aspherical lenses (Fig. 16) are often used - their surface profile is not a portion of a sphere or cylinder, but rather a more complex profile apt to minimize spherical aberrations. An alternative solution is working at high F/#'s, so that rays entering the lens far from the optical axis and causing spherical aberration cannot reach the sensor.

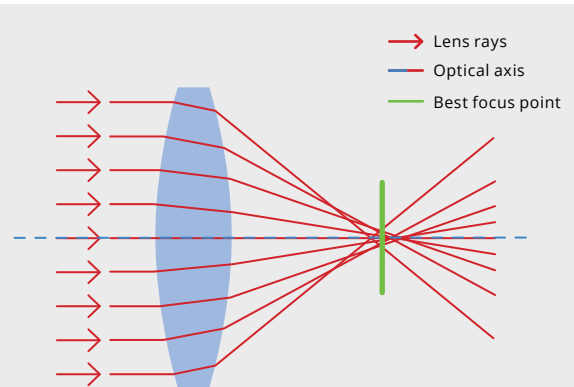

Fig. 15: Lens with spherical aberration

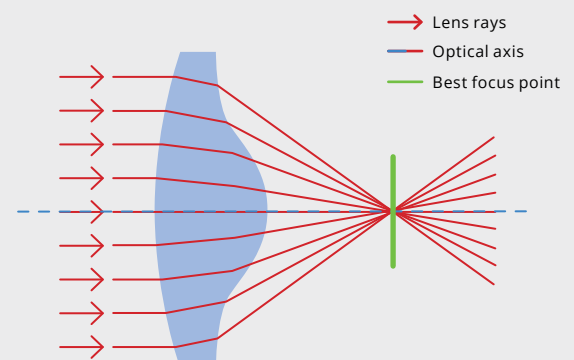

Fig. 16: Aspherical lens





### Chromatic aberration

The refractive index of a material is a number that describes the scattering angle of light passing through it - essentially how much rays are bent or refracted - and it is function of the wavelength of light. As white light enters a lens, each wavelength takes a slightly different path. This phenomenon is called dispersion and produces the splitting of white light into its spectral components, causing chromatic aberration. The effect is minimal at the center of the optics, growing towards the edges.

Chromatic aberration causes color fringes to appear across the image, resulting in blurred edges that make it impossible to correctly image object features. While an achromatic doublet can be used to reduce this kind of aberration, a simple solution when no color information is needed is using monochrome light. Chromatic aberration can be of two types: longitudinal (Fig. 17) and lateral (Fig. 18), depending on the direction of incoming parallel rays.

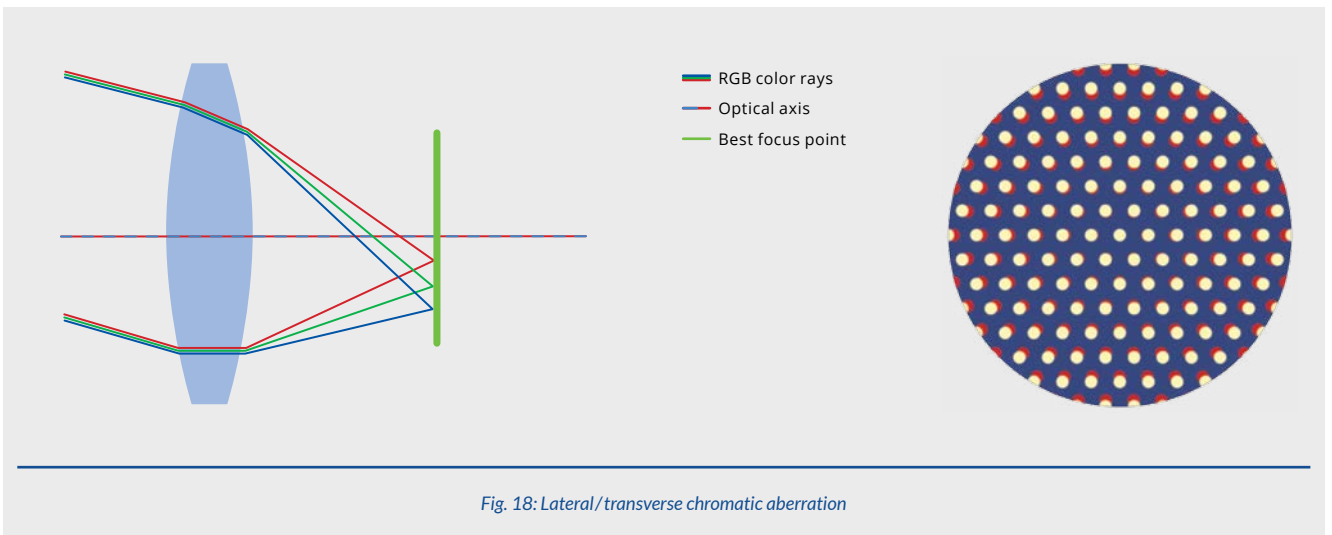
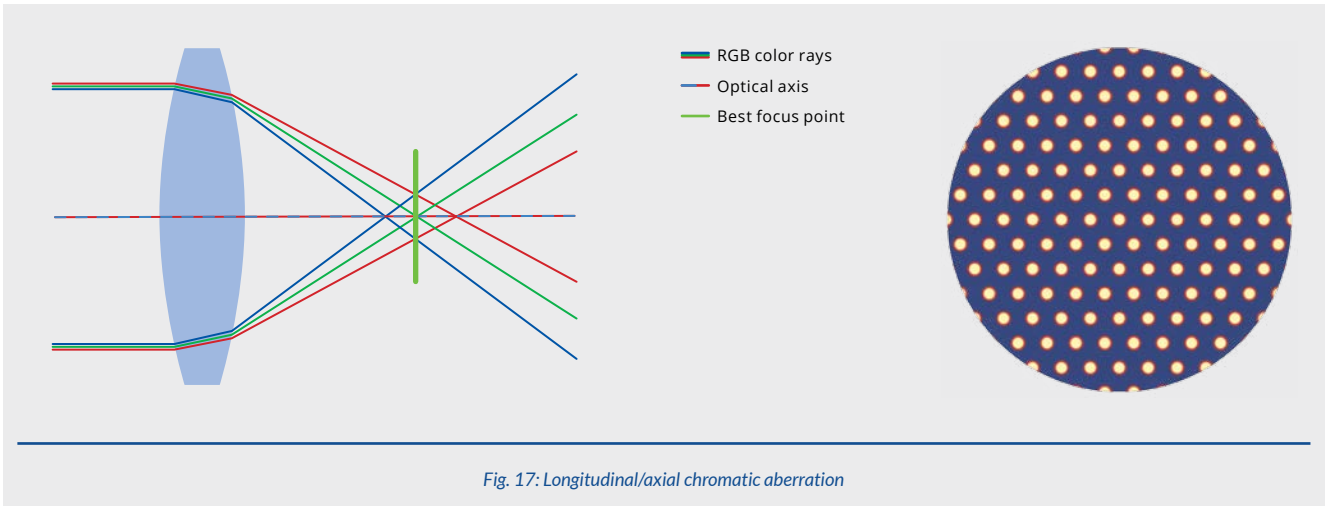



## Astigmatism

Astigmatism (Fig. 19) is an optical aberration that occurs when rays lying in two perpendicular planes on the optical axis have different foci.

This causes blur in one direction that is absent in the other direction. If we focus the sensor for the sagittal plane, we see circles become ellipses in the tangential direction and vice versa.

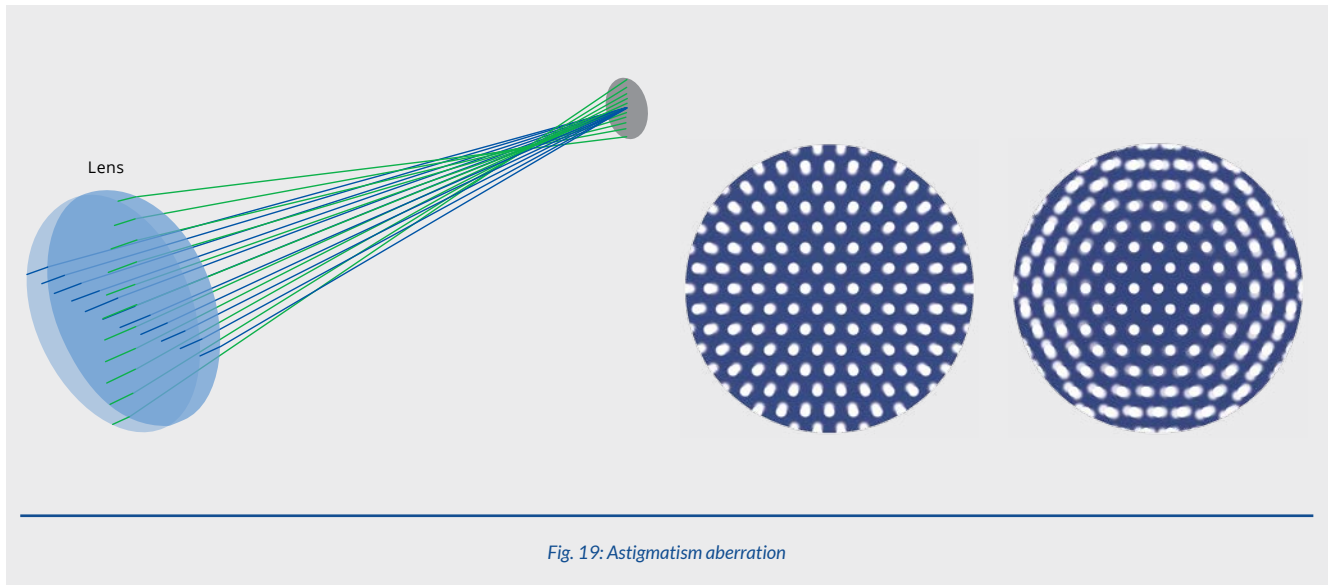

Fig. 19: Astigmatism aberration

## Coma

Coma aberration (Fig. 20) occurs when parallel rays entering the lens at a certain angle are brought to focus at different positions, depending on their distance from the optical axis.

A circle in the object plane will appear in the image as a comet-shaped element, which gives the name to this particular aberration effect.

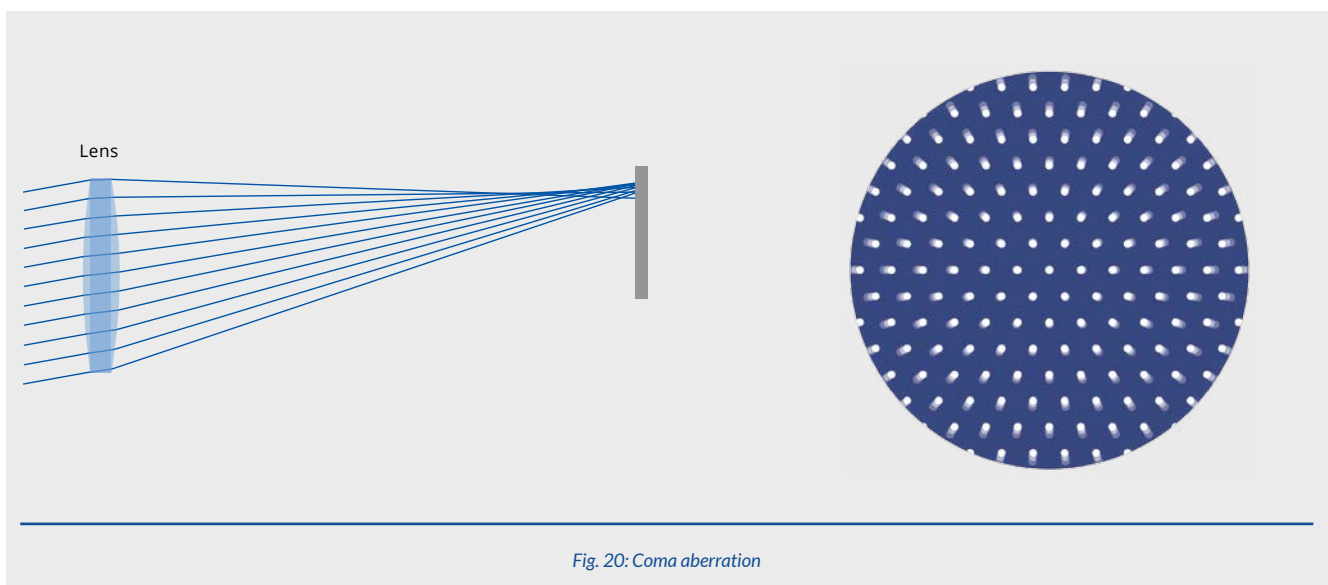

Fig. 20: Coma aberration



### Field curvature

Field curvature aberration (Fig. 21) describes the fact that parallel rays reaching the lens from different directions do not focus on a plane, but rather on a curved surface.

This causes radial defocusing, i.e. for a given sensor position, only a circular crown will be in focus.

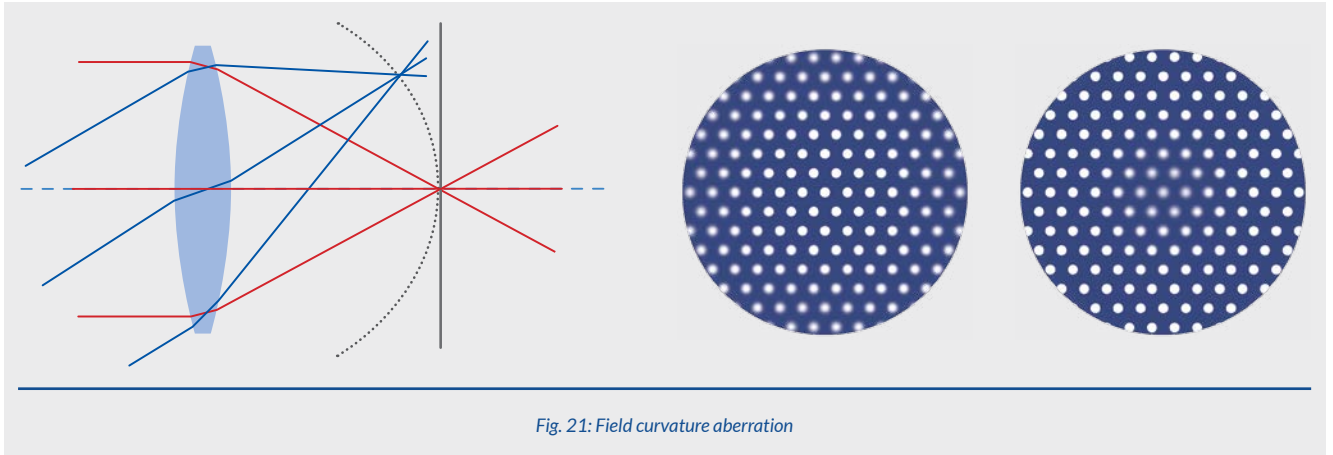

Fig. 21: Field curvature aberration

### Distortion

With a perfect lens, a squared element would only be transformed in size, without affecting its geometric properties. Conversely, a real lens always introduces some geometric distortion, mostly radially symmetric (as a reflection of the radial symmetry of the optics). This radial distortion can be of two kinds: barrel and pincushion distortion. With barrel distortion, image magnification decreases with the distance from the optical axis, giving the apparent effect of the image being wrapped around a sphere. With pincushion distortion image magnification increases with the distance from the optical axis. Lines that do not pass through the center of the image are bent inwards, like the edges of a pincushion.

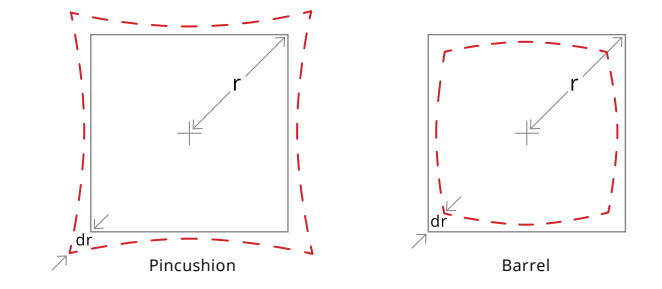

Fig. 22: Distortion

### What about distortion correction?

Since telecentric lenses are a real world object, they show some residual distortion which can affect measurement accuracy. Distortion is calculated as the percent difference between the real and expected image height and can be approximated by a second order polynomial.

If we define the radial distances from the image center as follows

$$Ra = \text{actual radius}$$

$$Re = \text{expected radius}$$

the distortion is computed as a function of Ra:

$$\text{dist}(Ra) = (Ra - Re)/Ra = c \cdot Ra^2 + b \cdot Ra + a$$

where a, b and c are constant values that define the distortion curve behavior; note that "a" is usually zero as the distortion is usually zero at the image center. In some cases, a third order polynomial could be required to get a perfect fit of the curve.

In addition to radial distortion, also trapezoidal distortion must be taken into account. This effect can be thought of as the perspective error due to the misalignment between optical and mechanical components, whose consequence is to transform parallel lines in object space into convergent (or divergent) lines in image space.

Such effect, also known as "keystone" or "thin prism", can be easily fixed by means of pretty common algorithms which compute the point where convergent bundles of lines cross each other.

An interesting aspect is that radial and trapezoidal distortion are two completely different physical phenomena, hence they can be mathematically corrected by means of two independent space transform functions which can also be applied subsequently.

An alternative (or additional) approach is to correct both distortions locally and at once: the image of a grid pattern is used to define the distortion error amount and its orientation zone by zone. The final result is a vector field where each vector associated to a specific image zone defines what correction has to be applied to the x,y coordinate measurements within the image range.



## Why GREEN light is recommended for telecentric lenses?

All lenses operating in the visible range, including OE Telecentric lenses, are achromatized through the whole VIS spectrum. However, parameters related to the lens distortion and telecentricity are typically optimized for the wavelengths at the center of the VIS range, that is green light. Moreover, the resolution tends to be better in the green light range, where the achromatization is almost perfect.

“Green” is also better than “Red” because a shorter wavelength range increases the diffraction limit of the lens and the maximum achievable resolution.

## Contrast, resolution and diffraction

### Contrast

Defects and optical aberrations, together with diffraction, contribute to image quality degradation. An efficient way to assess image quality is to calculate contrast, that is the difference in luminance that makes an object - its representation in the image or on a display - distinguishable. Mathematically, contrast is defined as

$$C = [I_{max} - I_{min}] / [I_{max} + I_{min}]$$

where  $I_{max}$  ( $I_{min}$ ) is the highest (lowest) luminance.

In a digital image, 'luminance' is a value that goes from 0 (black) to a maximum value depending on color depth (number of bits used to describe the brightness of each color). For typical 8-bit images (in grayscale, for the sake of simplicity), this value is  $2^8 - 1 = 255$ , since this is the number of combinations (counting from the zero 'black' string) one can achieve with 8 bits sequences, assuming 0-1 values for each.

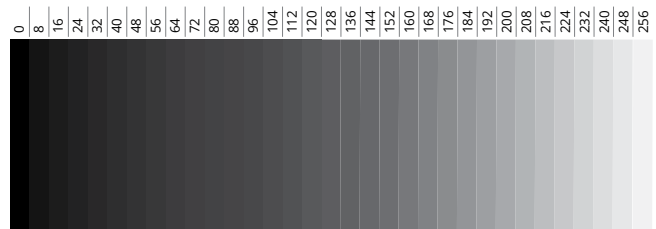

Fig. 23: Greyscale levels

### Lens resolving power: transfer function

The image quality of an optical system is usually expressed by its transfer function (TF). TF describes the ability of a lens to resolve features, correlating the spatial information in object space (usually expressed in line pair per millimeter) to the contrast achieved in the image.

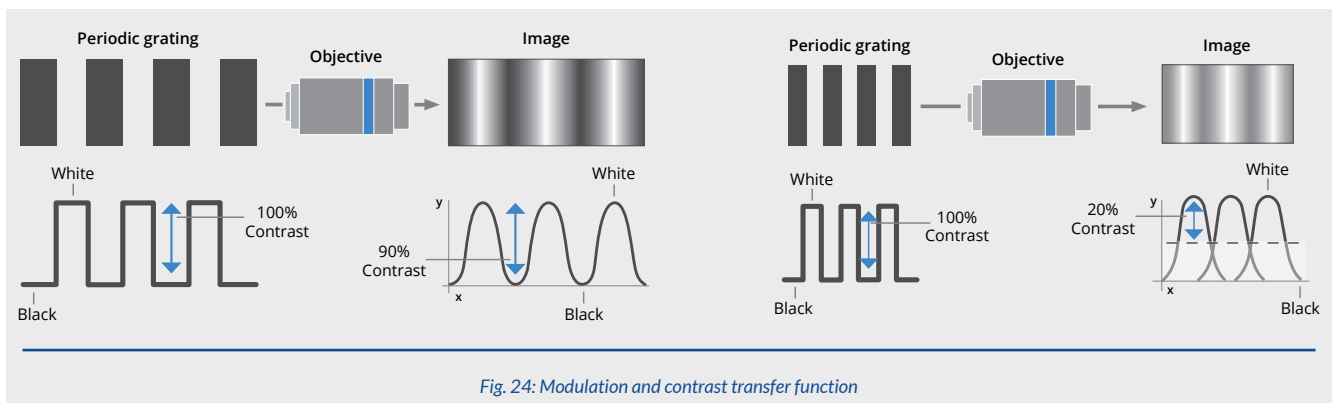

Fig. 24: Modulation and contrast transfer function

### What's the difference between MTF (Modulation Transfer Function) and CTF (Contrast Transfer Function)?

CTF expresses the lens contrast response when a “square pattern” (chessboard style) is imaged; this parameter is the most useful in order to assess edge sharpness for measurement applications. On the other hand, MTF is the contrast response achieved when imaging a sinusoidal pattern in which the grey levels range from 0 and 255; this value is more difficult to convert into any useful parameter for machine vision applications. The resolution of a lens is typically expressed by its MTF (modulation transfer function), which shows the response of the lens when a sinusoidal pattern is imaged.



However, the CTF (Contrast Transfer Function) is a more interesting parameter, because it describes the lens contrast when imaging a black and white stripe pattern, thus simulating how the lens would image the edge of an object. If  $t$  is the width of each stripe, the relative spatial frequency  $w$  will be

$$w = 1/(2t)$$

For example, a black and white stripe pattern with  $5 \mu\text{m}$  wide stripes has a spatial frequency of  $100 \text{ lp/mm}$ . The “cut-off frequency” is defined as the value  $w$  for which CTF is zero, and it can be estimated as

$$w_{\text{cut-off}} = 1/[WF/\# \cdot \lambda(\text{mm})]$$

For example, an Opto Engineering® TC23036 lens (WF/#h F/8) operating in green light ( $\lambda = 0.000587 \text{ mm}$ ) has a cut-off spatial frequency of about

$$w_{\text{cut-off}} = [8 \cdot 0.000587 \text{ mm}] = 210 \text{ lp/mm}$$

### Optics and sensor resolution

The cutoff spatial frequency is not an interesting parameter, since machine vision systems cannot reliably resolve features with very low contrast. It is thus convenient to choose a limit frequency corresponding to 20% contrast.

A commonly accepted criterion to describe optical resolution is the Rayleigh criterion, which is connected to the concept of resolution limit. When a wave encounters an obstacle - e.g. it passes through an aperture - diffraction occurs. Diffraction in optics is a physical consequence of the wave-like nature of light, resulting in interference effects that modify the intensity pattern of the incoming wavefront.

Since every lens is characterized by an aperture stop, the image quality will be affected by diffraction, depending on the lens aperture: a dot-like object will be correctly imaged on the sensor until its image reaches a limit size; anything smaller will appear to have the same image – a disk with a certain diameter depending on the lens F/# and on the light wavelength.

This circular area is called the **Airy disk**, having a radius of

$$r_A = 1.22 \lambda f / d$$

where  $\lambda$  is the light wavelength,  $f$  is the lens focal length,  $d$  is the aperture diameter and  $f/d$  is the lens F-number. This also applies to distant objects that appear to be small.

If we consider two neighboring objects, their relative distance can be considered the “object” that is subject to diffraction when it is imaged by the lens. The idea is that the diffraction of both objects’ images increases to the point that it is no longer possible to see them as separate. As an example, we could calculate the theoretical distance at which human eyes cannot distinguish that a car’s lights are separated.

The **Rayleigh’s criterion** states that two objects are not distinguishable when the peaks of their diffraction patterns are closer than the radius of the Airy Disk  $r_A$  (in image space).

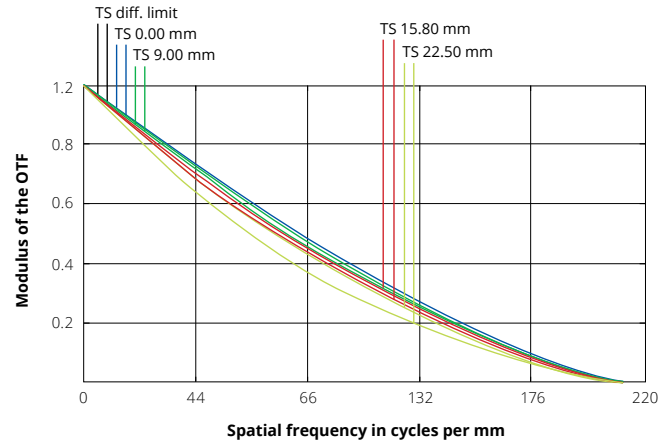

Fig. 25: MTF curves of TC23036 - green light

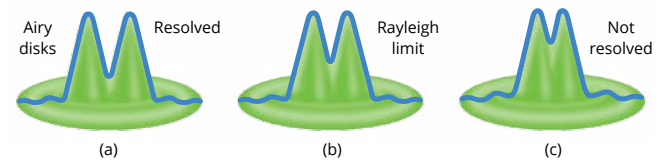

Fig. 26: Airy disk separation and the Rayleigh criterion

The Opto Engineering® TC12120 telecentric lens, for example, will not distinguish feature closer than

$$r_A = 1.22 \cdot 0.587 \mu\text{m} \cdot 8 = 5.7 \mu\text{m}$$

in image space (e.g. on the sensor). The minimum resolvable size in image space is always  $2 r_A$ , regardless of the real world size of the object. Since the TC12120 lens has 0.052X magnification and  $2r_A = 11.4 \mu\text{m}$ , the minimum real-world size of the object that can be resolved is  $11.4 \mu\text{m} / 0.052 = 220 \mu\text{m}$ .

For this reason, optics should be properly matched to the sensor and vice versa: in the previous example, there is no advantage to use a camera with  $2 \mu\text{m}$  pixel size, since every “dot like” object will always cover more than one pixel. In this case, a higher resolution lens or a different sensor (with larger pixels) should be chosen. On the other hand, a system can be limited by the pixel size, where the optics would be able to “see” much smaller features. The Transfer Function of the whole system should then be considered, assessing the contribution from both the optics and the sensor. It is important to remember that the actual resolution limit is not only given by the lens F/# and the wavelength, but also depends on the lens aberrations: hence, the real spatial frequency to be taken into account is the one described by the MTF curves of the desired lens.



## Reflection, transmission and coatings

When light encounters a surface, a fraction of the beam is **reflected**, another fraction is refracted (**transmitted**) and the rest is absorbed by the material. In lens design, we must achieve the best transmission while minimizing reflection and absorption. While absorption is usually negligible, reflection can be a real problem: the beam is in fact not only reflected when entering the lens (air-glass boundary) but also when it exits the lens (glass-air). Let's suppose that each surface reflects 3% of incoming light: in this case, a two lenses system has an overall loss of  $3*3*3*3\% = 81\%$ . Optical coatings – one or more thin layers of material deposited on the lens surface – are the typical solution: a few microns of material can dramatically improve image quality, lowering reflection and improving transmission.

**Transmission** depends considerably on the light wavelength: different kind of glasses and coatings helps to improve performance in particular spectral regions, e.g. UV or IR. Generally, good transmission in the UV region is more difficult to achieve.

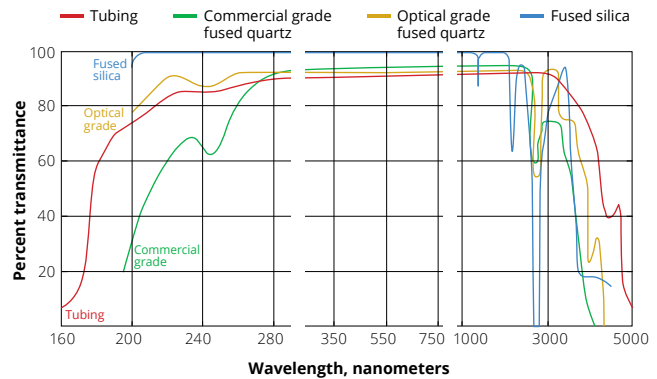

Fig. 27: Percent transmittance of different kind of glasses

**Anti-reflective (AR) coatings** are thin films applied to surfaces to reduce their reflectivity through optical interference. An AR coating typically consists of a carefully constructed stack of thin layers with different refractive indices. The internal reflections of these layers interfere with each other so that a wave peak and a wave trough come together and extinction occurs, leading to an overall reflectance that is lower than that of the bare substrate surface.

**Hard carbon anti-reflective HCAR coating:** HCAR is an optical coating commonly applied to Silicon and Germanium designed to meet the needs of those applications where optical elements are exposed to harsh environments, such as military vehicles and outdoor thermal cameras.

Anti-reflection coatings are included on most refractive optics and are used to maximize throughput and reduce ghosting. Perhaps the simplest, most common anti-reflective coating consists of a single layer of Magnesium Fluoride ( $MgF_2$ ), which has a very low refractive index (approx. 1.38 at 550 nm).

This coating offers highly protective properties coupled with good anti-reflective performance, protecting the outer optical surfaces from high velocity airborne particles, seawater, engine fuel and oils, high humidity, improper handling, etc.. It offers great resistance to abrasion, salts, acids, alkalis, and oil.





# Vignetting

Light that is focused on the sensor can be reduced by a number of internal factors, that do not depend on external factors.

**Mount vignetting** occurs when light is physically blocked on its way to the sensor. Typically this happens when the lens image circle (cross section of the cone of light projected by the lens) is smaller than the sensor size, so that a number of pixels are not hit by light, thus appearing black in the image. This can be avoided by properly matching optics to sensors: for example, a typical 2/3" sensor (8.45 x 7.07 mm, 3.45 μm pixel size) with 11 mm diagonal would require a lens with a (minimum) image circle of 11 mm in diameter.



Fig. 28: Example of an image showing vignetting

**Aperture vignetting** is connected to the optics F/#: a lens with a higher F/# (narrower aperture) will receive the same light from most directions, while a lens with a lower F/# will not receive the same amount of light from wide angles, since light will be partially blocked by the edges of the physical aperture.

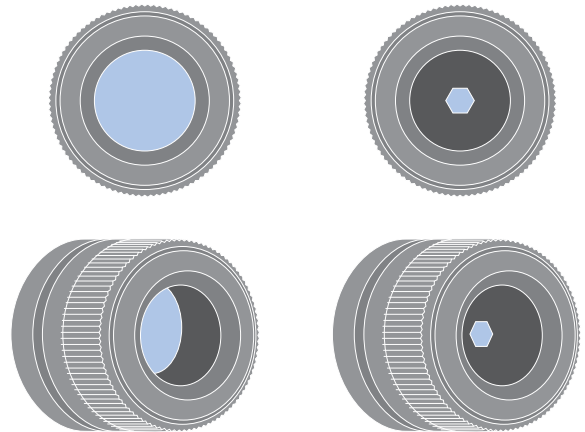

Fig. 29: Lens with low F/# (left) and high F/# (right) seen from the optical axis (top) and off-axis (bottom)

**Cos<sup>4</sup> vignetting** describes the natural light falloff caused by light rays reaching the sensor at an angle.

The light falloff is described by the cos<sup>4</sup>(θ) function, where θ is the angle of incoming light with respect to the optical axis in image space.

The drop in intensity is more significant at wide incidence angles, causing the image to appear brighter at the center and darker at the edges.

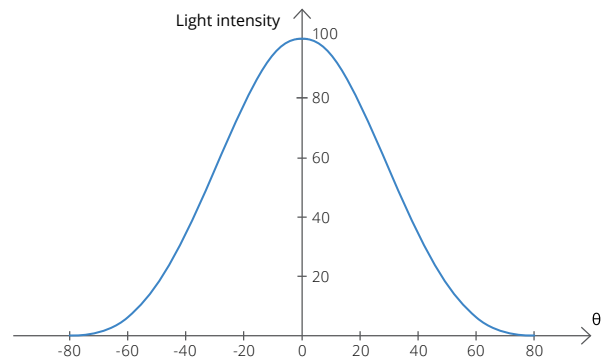

Fig. 30: Cos<sup>4</sup> vignetting. Light fall off caused by θ the angle with incoming light with respect to the optical axis





## Lens types

Many different types of optics are available in the industry, each tailored for different uses and applications. Below is a brief overview of the most common lens types, along with their working principles and common applications.

### TELECENTRIC LENSES

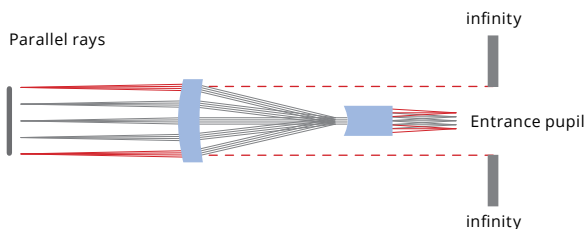

Fig. 31: Telecentric optics accepts only rays parallel to the optical axis

Telecentric lenses represent a special class of optics designed to only collect collimated light ray bundles (i.e. parallel to the optical axis, see Fig. 31), thus eliminating perspective errors.

Since only rays parallel to the optical axis are accepted, the magnification of a telecentric lens is independent of the object location. This unique feature makes telecentric lenses perfectly suited for measurement applications, where perspective errors and changes in magnification can lead to inconsistent measurements. Because of its design, the front element of a telecentric lens must be at least as large as the desired FOV, making these lenses inadequate to image very large objects.

The following drawings (Fig. 32) show the difference between common optics (entocentric) and telecentric lenses. Fixed focal length lenses are entocentric lenses, meaning that they collect rays diverging from the optical axis. This allows them to cover large FoVs but since magnification is different at different working distances, these lenses are not suited to determine the true dimensions of an object.

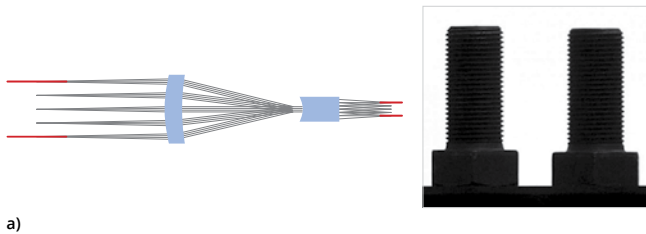

Fig. 32: a) The design of a telecentric lens is such that objects at different distances from the lens appear to have the same size

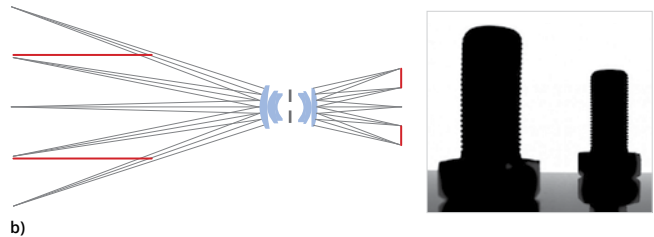

Fig. 32: b) With entocentric optics, a change in the working distance is seen on the sensor as perspective error

## Benefits of bi-telecentric lenses

### Better Magnification Constancy

Standard telecentric lenses accept ray cones whose axis is parallel to the main optical axis; if the lens is only telecentric in object space, ray cones passing through the optical system reach the detector from different angles depending upon the field position. Moreover the optical wavefront is completely asymmetric since incoming telecentric rays become non-telecentric in image space. As a consequence, the spots generated by ray cones on the detector plane change in shape and dimension from point to point in image space (the point-spread function becomes non-symmetrical and a small circular spot grows larger and turns elliptical as you move from the image center towards the borders).

Even worse, when the object is displaced, rays coming from a certain field point generate a spot that moves back and forth over the image plane, thus causing a significant change in magnification. For this reason non bi-telecentric lenses show a lower magnification constancy although their telecentricity might be very good if measured only in the object space.

Bi-telecentric lenses are telecentric in both object and image space, which means that principal rays are parallel not only when entering but also when exiting the lens. This feature is essential to overcome all the accuracy issues concerned with mono-telecentric lenses such as point spread function inhomogeneity and lack of magnification constancy through the field depth.

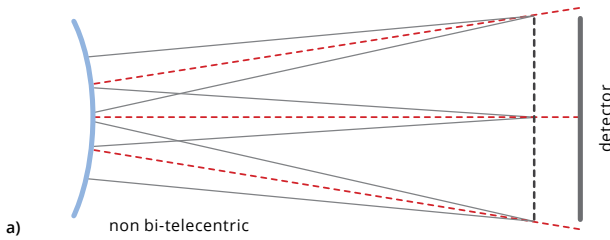

Fig. 33: (a) In a non image space telecentric lens (left) ray cones strike the detector at different angles

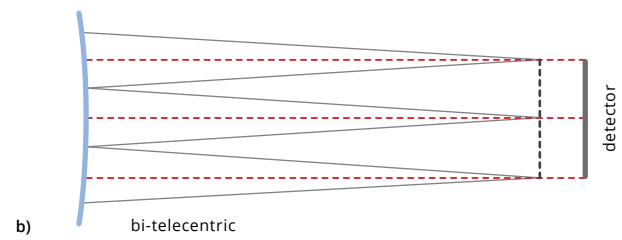

Fig. 33: (b) In a bi-telecentric lens (right) ray cones are parallel and reach the image sensor in a way independent on the field position

### Increased field depth

Field depth is the maximum acceptable displacement of an object from its best focus position. Beyond this limit the image resolution becomes poor, because the rays coming from the object can't create sufficiently small spots on the detector: blurring effect occurs because geometrical information carried by the optical rays spread over too many image pixels. Depth of field basically depends upon the optics  $F/\#$ , which is inversely proportional to the lens aperture diameter: the higher the  $f$ -number the larger the field depth, with a quasi-linear dependence. Increasing the  $F/\#$  reduces ray cones divergence, allowing for smaller spots to form onto the detector; however raising the  $F/\#$  over certain values introduces diffraction effects which limit the maximum achievable resolution. Bi-telecentricity is beneficial in maintaining a very good image contrast even when looking at very thick objects (see Fig. 34): the symmetry of the optical system and the rays parallelism help

the image spots with staying symmetrical, which reduces the blur effect. This results in a field depth being perceived as 20-30% larger compared to non bi-telecentric optics.



Fig. 34: Image of a thick object viewed throughout its entire depth by a bi-telecentric lens

### Even detector illumination

Bi-telecentric lenses boast a very even illumination of the detector, which comes useful in several applications such as LCD, textile and print quality control (Fig. 35).

When dichroic filters have to be integrated in the optical path for photometric or radiometric measurements, bi-telecentricity assures that the ray fan axis strikes the filter normal to its surface, thus preserving the optical band-pass over the whole detector area.



Fig. 35: A bi-telecentric lens is interfaced with a tunable filter in order to perform high resolution colour measurements. The image-side telecentricity ensures that the optical bandpass is homogeneous over the entire filter surface and delivers an even illumination of the detector, provided the object is evenly illuminated too.



## How to choose the right telecentric lens

Having fixed working distance and aperture, telecentric lenses are classified by their magnification and image circle. Choosing the right telecentric lens is easy: we must find the magnification under which the image fits the sensor.

**Example.** We need to measure the geometrical feature of a mechanical part (nut) using a telecentric lens and a 2048 x 2048, 5.5  $\mu\text{m}$  sensor. The nut is inscribed in a 10 mm diameter circle with 2 mm uncertainty on the sample position. What is the best choice?

Given the camera resolution and pixel size (2048 x 2048 pix, 5.5  $\mu\text{m}$ ), the sensor dimensions are calculated to be 11.26 x 11.26 mm. The FOV must contain a 12 mm diameter circle, hence the minimum magnification required is 0.938X.

The Opto Engineering® TC23009 telecentric lens (M=1.000X, image circle 11 mm) would give a FOV of 11.26 mm x 11.26 mm, but because of mechanical vignetting the actual FOV is only a 11 mm diameter circle. In this case, if a more accurate part placement cannot be guaranteed, a lens with lower mag or a larger image circle must be chosen.

Using the Opto Engineering® TC2MHR016-x lens (M=0.767X, image circle 16.0 mm) we find a FOV of 14.68 x 14.68 mm which is a very close match.

## UV TELECENTRIC OPTICS

Since the diffraction limit allows higher resolution at shorter wavelengths (see Fig. 36), UV optics can reach superior results compared to standard lenses and can efficiently operate with pixels as small as 1.75  $\mu\text{m}$ .

For example, the Opto Engineering® TCUV series telecentric lenses operate in the near UV range and deliver extremely high resolution for very demanding measurement applications.

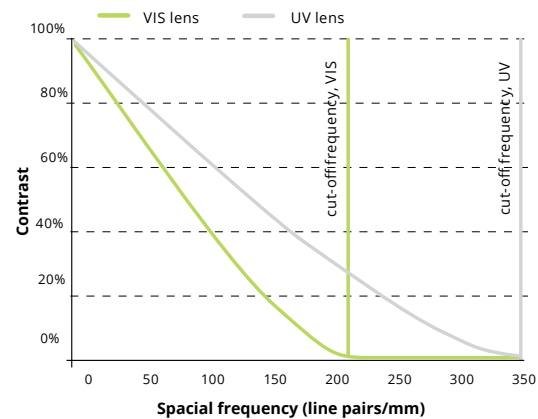

Fig. 36: The graph shows the limit performances (diffraction limit) of two lenses operating at working F/# 8. The standard lens operates at 587 nm (green light) while the UV lens operates at 365 nm



### *Why Opto Engineering® telecentric lenses don't integrate an iris?*

Our TC lenses don't feature an iris, but we can easily adjust the aperture upon request prior to shipping the lens, without any additional costs or delays for the customer.

The reasons why our lenses don't feature an iris are so many that the proper question would be "why other manufacturers integrate irises?":

- adding an iris makes a lens more expensive because of a feature that would only be used once or twice throughout the product life
- iris insertion makes the mechanics less precise and the optical alignment much worse
- we would be unable to test the lenses at the same aperture that the customer would be using
- iris position is much less precise than a metal sheet aperture: this strongly affects telecentricity
- the iris geometry is polygonal, not circular: this changes the inclination of the main rays across the FOV, thus affecting the lens distortion and resolution
- irises cannot be as well centered as fixed, round, diaphragms: proper centering is essential to ensure a good telecentricity of the lens
- only a circular, fixed, aperture makes brightness the same for all lenses
- an adjustable iris is typically not flat and this causes uncertainty in the stop position, which is crucial when using telecentric lenses!
- iris is a moving part that can be dangerous in most industrial environments. Vibrations could easily disassemble the mechanics or change the lens aperture
- the iris setting can be accidentally changed by the user and that would change the original system configuration
- end users prefer having less options and only a few things that have to be tuned in a MV system
- apertures smaller than what is delivered by OE as a standard will not make sense as the resolution will decay because of diffraction limit; on the other hand, much wider apertures would cause a reduction of the field depth.

The standard aperture of OE lenses is meant to optimize image resolution and field depth.

### *Why OE Telecentric lenses don't feature a focusing mechanism?*

As with the iris, a focusing mechanism would generate a mechanical play in the moving part of the lens, thus making it worse the centering of the optical system and also causing trapezoidal distortion.

Another issue is concerned with radial distortion: the distortion of a telecentric lens can be kept small only when the distances between optical components are set at certain

values: displacing any element from the correct position would increase the lens distortion. A focusing mechanism makes the positioning of the lenses inside the optical system uncertain and the distortion value unknown: the distortion would then be different from the values obtained in our quality control process.



## 360° OPTICS



Many machine vision applications require a complete view of an object surface since many features to be inspected are located on the object sides rather than on top.

Most cylindrical objects such as bottles and containers, as well as many kinds of mechanical parts require an inspection of the side surfaces to detect scratches and impurities or to read barcodes or, again, to ensure that a label has been printed correctly.

In these cases, the most common approach is to use multiple cameras (usually 3 or 4) in order to achieve several side views of the part, in addition to the top view. This solution, besides increasing the cost of the system, often creates a bottleneck in the system performances, since the electronics or software must process different images from different cameras simultaneously. In other cases, vision engineers prefer to scan the outer surface with line scan camera systems.

This approach also shows many technical and cost disadvantages: the object must be mechanically rotated in the FOV which also affects the inspection speed; moreover, line-scan cameras require very powerful illumination. Also, the large size of linear detectors increases the optical magnification of the system, thus reducing field depth.

The 360° optics category encompasses different optical solutions that capture rays diverging from the object (see Fig. 37), thus imaging not only the object surface in front of the lens, but also the object's lateral surface (see optical diagram below). The following images illustrate the working principle applied to a pericentric lens (PC), a catadioptric lens (PCCD), a pinhole lens (PCHI) and a boroscope lens (PCPB). Other 360° optical solutions combine telecentric optics and mirror arrays, allowing you to get a complete view of a sample with just one camera (TCCAGE, PCPW and PCMP series).

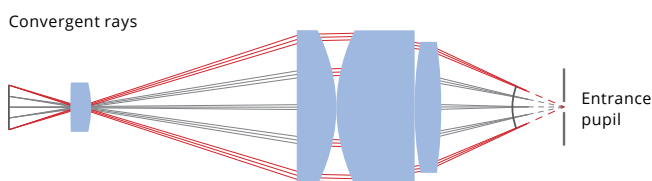

Fig. 37: Pericentric lens type. The entrance pupil is located in front of the lens

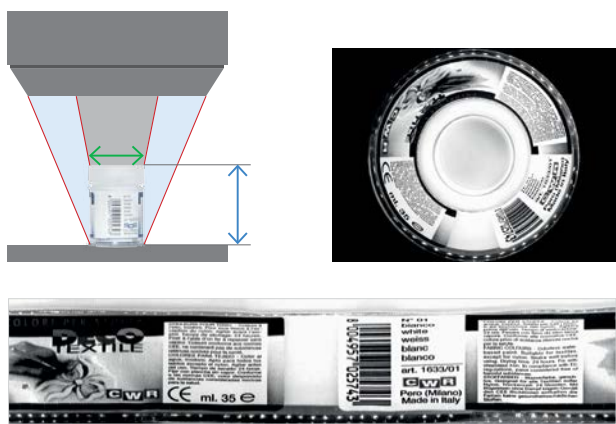

Fig. 38: Opto Engineering® PC lens optical scheme, sample image and unwrapped image

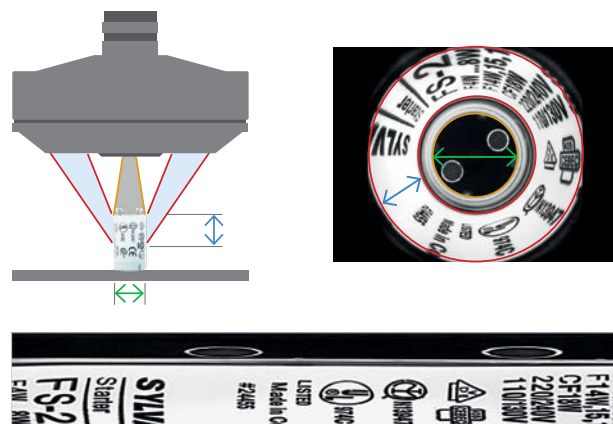

Fig. 39: Opto Engineering® PCCD optical scheme, sample image and unwrapped image

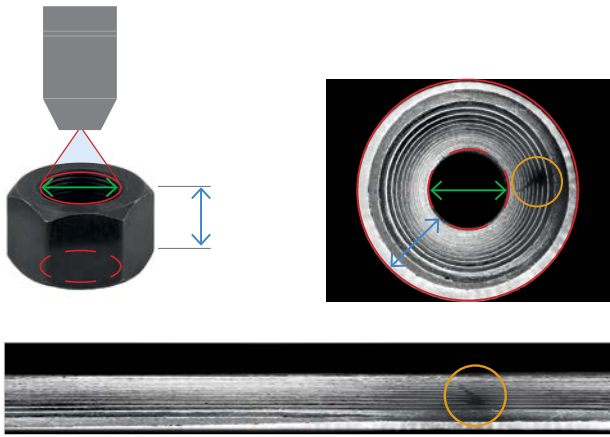

Fig. 40: Opto Engineering® PCHI optical scheme, sample image and unwrapped image

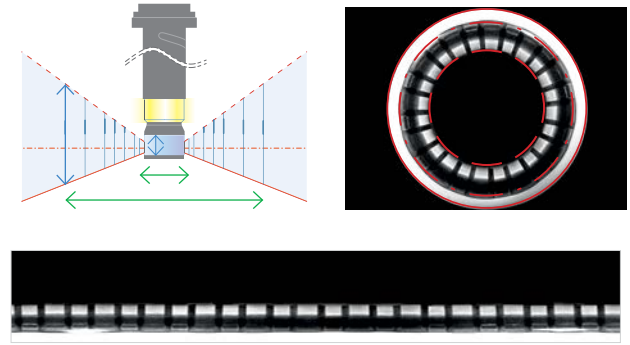

Fig. 41: Opto Engineering® PCPB optical scheme, sample image and unwrapped image

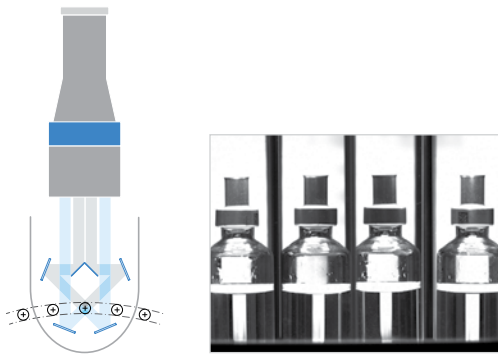

Fig. 42: Opto Engineering® TCCAGE optical scheme and sample image

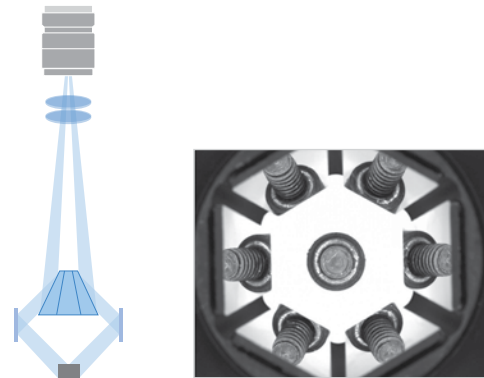

Fig. 43: Opto Engineering® PCPW: optical scheme and sample image

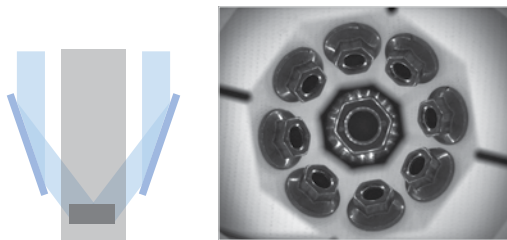

Fig. 44: Opto Engineering® PCMP: optical scheme and sample image

## MACRO LENSES



**M**acro lenses are fixed focal length lenses whose working distance is comparable to their focal length. The recommended working distance from the object is usually fixed, hence macro optics are usually described by their magnification.

Since macro lenses are specifically designed to image small and fixed FoVs, they tend to have extremely low geometrical distortion. For example, the distortion of Opto Engineering® MC series lenses range from <0.05% to <0.01%.





## FIXED FOCAL LENGTH LENSES

Fixed focal length lenses are **F**entocentric lenses, meaning that they collect rays diverging from the optical axis (see Fig. 45). Fixed focal length lenses are commonly used optics in machine vision, being affordable products that are well suited for standard applications.



Knowing the basic parameters - focal length and sensor size - it is easy to calculate the field of view and working distance; the focus can be adjusted from a minimum working distance to infinity; usually also the iris is controlled mechanically, allowing you to manually adjust the lens F/# and consequently the light intensity, field depth and resolution.

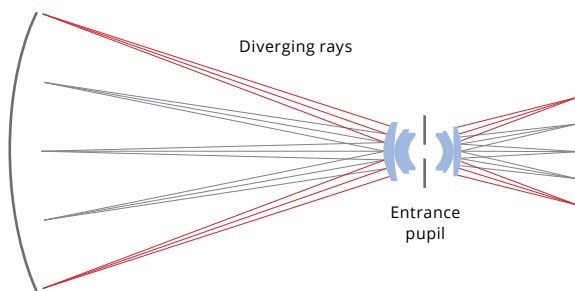

Fig. 45: Entocentric optics accept rays diverging from the lens

Fixed focal length lenses are inexpensive and versatile, but they are not suitable for all applications.

They usually introduce significant perspective errors and geometric distortion that are incompatible with precision measurement applications.

Also, the manually adjustable iris and focus introduce some mechanical play, which makes these lenses not ideal for applications requiring very consistent and repeatable settings.

**Example.** A ceramic tile (100 x 80 mm) must be inspected with a fixed focal length lens from 200 mm away. Which lens would you choose? The Camera sensor has 2592 x 1944 res, with 2.2  $\mu\text{m}$  pixels.

Recalling basic lens equations:

$$1/s' (+) - 1/s (-) = 1/f (+)$$

$$M = h'/h = s'/s$$

we find:

$$1/s (h/h' - 1) = 1/f$$

thus

$$WD = -s = -f (h/h' - 1)$$

or consequently:

$$f = s / (h/h' - 1)$$

and also

$$h = h' (1 + s/f)$$

keeping in mind that  $s$  and  $h'$  (object position with respect to the lens and image height) are customarily negative, while  $f$  and  $h$  (focal length and object height) are customarily positive. Also, in machine vision, we take  $h$  as the maximum value for the desired field of view and  $h'$  as the short side of the sensor, to make sure the minimum requested field of view is covered.

Given the sensor resolution and pixel size, we can calculate the sensor dimensions. We set  $h' = -4.28$  mm and  $h = 100$  mm. Hence, setting  $s = -200$  mm we find  $f = 8.2$  mm. With a standard 8 mm lens we would cover a slightly wider FOV (137 x 102 mm).

## Extension tubes

For most standard lenses the working distance (WD) is not a fixed parameter.

The focusing distance can be changed by adjusting a specific knob. Nevertheless, there is always a minimum object distance (MOD) below which focusing becomes impossible. Adding an extension tube (see Fig. 46) between the lens and the camera increases the back focal length, making it possible to reduce the MOD.

This also increases the magnification of the lens or, in other words, reduces the FOV.

While very common in the vision industry, this procedure should be avoided as much as possible, because it degrades the lens performance (resolution, distortion, aberrations, brightness, etc.).

In these cases, it is recommended to use lenses natively designed to work at short working distances (macro lenses).



Fig. 46: Extension tubes for fixed focal length lenses



## VARIFOCAL LENSES

Varifocal lenses are lenses with variable focal length, which can be adjusted by moving groups of optical elements with respect to each other inside the lens. The variable focal length allows for multiple combinations of working distances and magnifications, offering several different configurations with a single lens. Varifocal lenses, though, have the same reliability issues of fixed focal length lenses, plus more uncertainty caused by the relative motion of lens groups inside the assembly.



## ZOOM LENSES



Zoom lenses (parfocal lenses) are a special type of varifocal optics in which the working distance is kept constant when changing focal length (i.e. focus is maintained throughout the process). Actually, a zoom lens is generally defined as a lens that can change magnification without changing its working distance: in this category, we can also find macro zoom (e.g. Opto Engineering® MCZR and MZMT) and telecentric zoom lenses (Opto Engineering® TCZR).

## SCHEIMPFLUG OPTICS

Scheimpflug optics are a special class of lenses, either of the fixed focal, macro or telecentric type, designed to meet the Scheimpflug criterion.

Suppose that the object plane of an optical setup is not parallel to the image plane (e.g. a camera-lens system imaging a flat target at 45°): this causes the image to be sharp only where the focus plane and the target plane intersect.

Since the image and object planes are conjugated, tilting the first plane by a certain angle will also cause the latter to tilt by a corresponding angle. Once the focus plane is aligned to the target plane, focus across the image is restored.

The angle at which the sensor plane must be tilted is given by the Scheimpflug criterion:

$$\tan(\theta') = M \cdot \tan(\theta)$$

$$\theta' = \text{atan}(M \cdot \tan(\theta))$$

where  $M$  is the lens magnification,  $\theta'$  is the image plane tilt angle (i.e. on the sensor side) and  $\theta$  is the object plane tilt angle.

It is clear that at high magnifications this condition is impossible to meet, since an object plane tilted by 45° would require to tilt the sensor by 80°, causing severe mechanical and vignetting issues (cf. Fig. 47, where  $M=5$  black,  $M=1$  blue,  $M=0.25$  red).

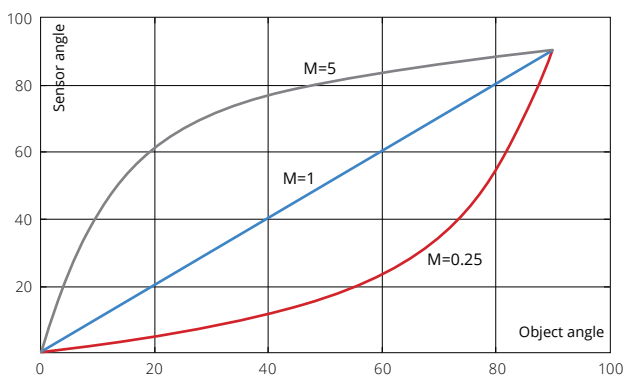

Fig. 47: Relationship between object ( $\theta$ ) and sensor angle ( $\theta'$ ) at different magnification  $M$

Image plane tilting is practically realized by changing the angle of the camera with respect to the optics by means of special tiltable mounts: the picture below illustrates an example of a Scheimpflug telecentric setup.

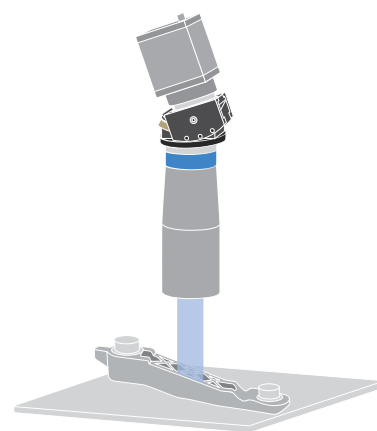

Fig. 48: Example of Scheimpflug telecentric setup



## IR OPTICS

In machine vision, we find a number of interesting and high tech applications of IR radiation: the imaging process in some regions of the spectrum requires specifically designed lenses called **IR optics**.

All objects with an absolute temperature over 0 K emit infrared (IR) radiation. Infrared radiant energy is determined by the temperature and emissivity of an object and is characterized by wavelengths ranging from 0.76  $\mu\text{m}$  (the red edge of the visible range) to 1000  $\mu\text{m}$  (beginning of microwaves range). The higher the temperature of an object, the higher the spectral radiant energy, or emittance, at all wavelengths and the shorter the peak wavelength of the emissions. Due to limitations on detector range, IR radiation is often divided into three smaller regions based on the response of various detectors.

**SWIR (0.9-1.7  $\mu\text{m}$ )** is also called the «reflected infrared» region since radiation coming from a light source is reflected by the object in a similar manner as in the visible range.

SWIR imaging requires some sort of illumination in order to image an object and can be performed only if some light, such as ambient moon light or stars light is present. In fact the SWIR region is suitable for outdoor, night-time imaging. SWIR imaging lenses are specifically designed, optimized, and anti-reflection coated for SWIR wavelengths.

Indium Gallium Arsenide (InGaAs) sensors are the primary sensors used in SWIR, covering typical SWIR band, but can extend as low as 0.550  $\mu\text{m}$  to as high as 2.5  $\mu\text{m}$ .

A large number of applications that are difficult or impossible to perform using visible light are possible using SWIR InGaAs based cameras: nondestructive identification of materials, their composition, coatings and other characteristics, Electronic Board Inspection, Solar cell inspection, Identifying and Sorting, Surveillance, Anti-Counterfeiting, Process Quality Control, etc... When imaging in SWIR, water vapor, fog, and certain materials such as silicon are transparent. Additionally, colors that appear almost identical in the visible may be easily differentiated using SWIR.



**MWIR (3-5  $\mu\text{m}$ ) and LWIR (8-14  $\mu\text{m}$ )** regions are also referred to as “thermal infrared” because radiation is emitted from the object itself and no external light source is needed to image the object. Two major factors determine how bright an object appears to a thermal imager: the object’s temperature and its emissivity (a physical property of materials that describes how efficiently it radiates). As an object gets hotter, it radiates more energy and appears brighter to a thermal imaging system.

Atmospheric obscurants cause much less scattering in the MWIR and LWIR bands than in the SWIR band, so cameras sensitive to these longer wavelengths are highly tolerant of smoke, dust and fog.

- MWIR collects the light in the 3  $\mu\text{m}$  to 5  $\mu\text{m}$  spectral band. MWIR cameras are employed when the primary goal is to obtain high-quality images rather than focusing on temperature measurements and mobility. The MWIR band of the spectrum is the region where the thermal contrast is higher due to blackbody physics; while in the LWIR band there is quite more radiation emitted from terrestrial objects compared to the MWIR band, the amount of radiation varies less with temperature: this is why MWIR images generally provide better contrast than LWIR. For example, the emissive peak of hot engines and exhaust gasses occurs in the MWIR band, so these cameras are especially sensitive to vehicles and aircraft. The main detector materials in the MWIR are InSb (Indium antimonide) and HgCdTe (mercury cadmium telluride) also referred to as MCT and partially lead selenide (PbSe).

- LWIR collects the light in the 8  $\mu\text{m}$  to 14  $\mu\text{m}$  spectral band and is the wavelength range with the most available thermal imaging cameras. In fact, according to Planck’s law, terrestrial targets emit mainly in the LWIR. LWIR systems applications include thermography/temperature control, predictive maintenance, gas leak detection, imaging of scenes which span a very wide temperature range (and require a broad dynamic range), imaging through thick smoke, etc... The two most commonly used materials for uncooled detectors in the LWIR are amorphous silicon (a-Si) and vanadium oxide (VO<sub>x</sub>), while cooled detectors in this region are mainly HgCdTe.

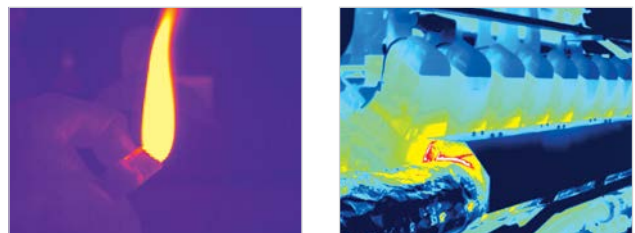

**Athermalization.** Any material is characterized by a certain temperature expansion coefficient and responds to temperature variations by either increasing or decreasing its physical dimensions. Thus, thermal expansion of optical elements might alter a system’s optical performance causing defocusing due to a change of temperature. An optical system is athermalized if its critical performance parameters (such as Modulation Transfer Function, Back Focal Length, Effective Focal Length, ...) do not change appreciably over the operating temperature range.

Athermalization techniques can be either active or passive. Active athermalization involves motors or other active systems to mechanically adjust the lens elements’ position, while passive athermalization makes use of design techniques aimed at compensating for thermal defocusing, by combining suitably chosen lens materials and optical powers (optical compensation) or by using expansion rods with very different thermal expansion coefficients that mechanically displace a lens element so that the system stays in focus (mechanical compensation).