

**Optimal Scheduling and Dispatch for
Hydroelectric Generation**

by

Nenad Tufegdžić, B.Sc.E.E, M.Sc.E.E

Department of Electrical and Electronic Engineering

submitted in fulfilment of the requirements

for the degree of

Doctor of Philosophy

University of Tasmania, January, 1997

Statement of Originality

This thesis contains no material which has been accepted for award of any other higher degree or graduate diploma in any tertiary institution. To best of my knowledge and belief, this thesis also contains no material previously published or written by another person, except where due reference is made.

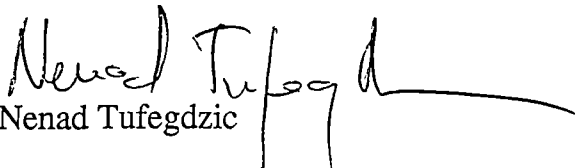
Nenad Tufegdzic

This thesis may be made available for loan and limited copying in accordance with the Copyright Act 1968.



For Stefan and Maja

Abstract

The optimal operation of a power system has been investigated since early days of power systems. Special attention has been given to the optimal generation schedule, because significant savings can be achieved in this area. As predominantly hydro systems are not common, treatment of hydro in many cases has been connected with thermal operation and thermal fuel cost. Today with the open electricity market becoming reality in many countries, and decentralisation of the power industry representing the main trend, an independent hydro generator will become a reality and the necessity for optimisation of the predominantly or solely hydro system will increase.

The major factors which affect optimal operation of the hydro system are:

- Operation at maximum efficient point
- Target level achievement (connected with mid and long term optimal operation)
- Inflow (and load) uncertainty
- Operation at the best head
- Start up cost

The new algorithm has been developed to take into account all those factors and produce optimal operation for a predominantly hydro system.

The new algorithm presents real time hydro scheduling which is performed

through regular rescheduling and look ahead dynamic economic dispatch. The full model is implemented including head variation and start-up costs.

Mixed Integer Linear Programming (MILP) is chosen as the solution algorithm, because the linear programming part models the hydro network very effectively and the integer variables can be used to control the unit start-up and shut-down behaviour.

The new techniques are developed to accommodate implementation of the MILP algorithm, such as power balance constraint relaxation, specific search techniques for integer solution and more detailed connection with mid-term optimisation.

The algorithm is implemented on the Tasmanian Hydro Electric Commission's hydro system. It is tested off-line using historical operating plans. A conservative estimate is that the savings will be up to six hours daily of an operator's time plus 0.5% in annual stored energy savings. There is the possibility for savings in the mid term optimisation by decreasing the risk of spill through better control of short term storage levels.

Acknowledgments

There are many people, and a number of organisations, that I would like to thank for their support and encouragement during the course of this study. Special thanks to my supervisor, Dr. Michael Negnevitsky for his advises and guidance and Mr. Paul Hyslop, project manager of EMS project for his encouragement and support during the project. I would like to thank Mr. Walter Stadlin from Macro Corporation, USA for advise and support during the project. I would also like to extend my appreciation to the University of Tasmania and Hydro Electric Commission of Tasmania, especially System Operation Group.

Contents

Abstract	iv
Acknowledgments	vi
Contents	vii
List of Figures	xi
Preface	xiv
Abbreviations	xvii
Glossary	xix
1. Introduction	1
1.1. Short-term scheduling	7
1.2. Real-time economic dispatch	14

2. Review of Hydro Power Plants Optimisation	18
2.1. Introduction	18
2.2. An overview of the methods	22
2.3. A new approach	26
3. Optimisation in a Pure Hydro System and Independent Hydro Generation in Open Electricity Market	30
3.1. Introduction	30
3.2. Effect of the long-term and mid-term planning on real-time scheduling	33
3.3. Effect of the load and inflow prediction on real-time scheduling	34
4. Algorithm for the Real-time Short-term Hydro Scheduling	36
4.1. Introduction	36
4.2. Energy allocation function	38
4.3. Generation scheduling function	44

4.4.Dynamic hydro economic dispatch function	46
5. Mathematical Model of the Large Scale Hydro System	49
5.1.Introduction	49
5.2.Energy allocation hydro simulator	50
5.3.Generation scheduling mathematical model	51
5.3.1. Introduction	51
5.3.2. Generator model	52
5.3.3. Constraints model	59
5.3.4. Objective function	74
5.4.Dynamic hydro economic dispatch mathematical model	77
5.4.1. Introduction	77
5.4.2. Generator model	77
5.4.3. Constraints model	79
5.4.4. Objective function	80
6. Case Studies: Hydro Electric Power System of Tasmania	82
6.1.Introduction	82
6.2.Example of the real system schedule	83
6.3.Performance of the new algorithm	92

7. Summary and Future Work	95
7.1. Results and Contributions	95
7.1.1. An overview	95
7.1.2. Model improvements	97
7.1.3. Algorithm improvements	98
7.1.4. Practical implementation	99
7.2. Future work	99
Appendix	101
A: Typical machine curves used in the model	101
B: Tasmanian map with powerstations an high voltage network	108
C: Author's thesis based publications	110
References	139
Bibliography	144

List of Figures and Tables

1.1.	Figure:Planning hierarchy	2
1.2.	Figure:A typical load curve	4
1.3.	Figure:Short-term scheduling problem structure	8
2.1.	Figure:P/q curve	25
2.2.	Figure:Eff/q curve	25
2.3.	Figure:Functional HHierarchy	27
2.4.	Figure:Flow chart of the main functions	28
3.1.	Figure: Hydro optimisation process	31
3.2.	Table: Comparison of different scheduling enviroments	32
4.1.	Figure: Flow chart of the main functions	37

4.2.	Figure: Energy allocation flow chart	40
4.3.	Figure: Incremental curves	42
4.4.	Figure: Typical reservoir model	45
5.1.	Figure: Maximum efficiency flow vs gross head	54
5.2.	Figure: Unit input/output curve	56
5.3.	Figure: Multimachine input/output curve	58
5.4.	Figure: Fixed run unit input/output curve	59
5.5.	Figure: Reservoir spill flow vs volume	67
5.6.	Figure: Reservoir target levels penalty function	69
5.7.	Figure: Cost function	75
5.8.	Figure: Station input/output curve	78
6.1.	Figure: Demand/generation curve	84
6.2.	Figure: 'Frequency station' generation (Gordon)	85
6.3.	Figure: Savings based on maximum efficiency deviation operation	85

6.4.	Figure: Original HSC plan	86
6.5.	Figure: First option for decommitment	87
6.6.	Figure: Second option for decommitment	87
6.7.	Figure: Operation of one station (Poatina)	88
6.8.	Figure: Extra 50MW load	89
6.9.	Figure: Different operation for the same energy	90
6.10.	Figure: Lake levels based on different generation timing	90
6.11.	Figure: Operation of Gordon power station	92
6.12.	Figure: Operation of Devils Gate power station	93
6.13.	Figure: Operation of Anthony power station	93

Preface

The original purpose of this work was to develop a short-term hydro scheduling and real-time economic dispatch optimisation for a pure hydro system, to be used as a part of Hydro Electric Commission's new Energy Management System. The thesis also discusses implementation of the algorithm in the open electricity market environment and possible use of the algorithm for the optimisation of the hydro part of a mixed hydro thermal system. Although coordinated approach has been implemented in the real pure hydro system operated by the Hydro Electric Commission Tasmania, further improvements can be included to decrease computational time and include long-term hydro planning.

The work reported in the thesis has taken place between September 1992 and December 1996. The research was initiated in the Hydro Electric Commission of Tasmania, where most of the research was performed. In October 1992 the research was continued in parallel on Faculty of Electrical and Electronic Engineering, University of Tasmania, where the work was completed.

Thesis Organisation

The thesis is organised into seven chapters. The first two chapters are

introductory in nature. The first chapter represents introduction into short-term scheduling and dispatch in the power systems and present summary of present state in this area of research. The second chapter presents a brief overview of different optimisation techniques used to solve the hydro optimisation problem. It discusses the reasons why the new algorithm has been chosen with a reference list of specific approaches. The third chapter defines the optimisation problem of a pure hydro system. It also introduces similar problem for the independent hydro generator in open electricity market environment. The fourth chapter explains a new algorithm used for the optimisation. Chapter five explains a detail mathematical model used in the optimisation process. The sixth chapter discusses application of the algorithm on the real hydro electric system operated by the Hydro Electric Commission, Tasmania. Chapter seven concludes the thesis with the emphasis on the achievements and recommendations and areas of further research.

Supporting Publications

A number of technical journals and conferences papers connected to the thesis are listed below.

1. N.Tufegdzcic, P.Hyslop, W.Stadlin, "A Unique Concept for Hydro Economic Dispatch", Proceedings of the 1993 ISEDEM symposium on Electricity Distribution and Energy Management, Singapore, 1993
2. N.Tufegdzcic, R.J.Frowd, W.O.Stadlin, "A Coordinated Approach for Real-Time Short-Term Hydro Scheduling", IEEE 96 WM 169-3 PWRs, Baltimore, USA

3. N.Tufegdžic, P.Hyslop, "An Optimal Real-Time Short Term Operation of Independent Hydro Generator Company in the Open Electricity Market", accepted for publishing in Electric Power Systems Research

Reprints of publications are provided in the appendix.

Abbreviations

The following abbreviations is used in the thesis:

MILP	- Mixed Integer Linear Programming
LP	- Linear Programming
DP	- Dynamic Programming
cumec	- cubic meter per second
hr	- hour
eff	- efficiency
SCADA	- Supervisory Control and Data Acquisition
AGC	- Automatic Generation Control
HED	- Hydro Economic Dispatch

DHED	- Dynamic Hydro Economic Dispatch
HSC	- Hydro Scheduling and Commitment
EA	- Energy Allocation
GS	- Generation Scheduling
HS	- Hydro Simulator
RTHSC-EA	- Real-Time Hydro Scheduling and Commitment - Energy Allocation
RTHSC-GS	- Real-Time Hydro Scheduling and Commitment - Generation Scheduling
RTHSC-DHED	- Real-Time Hydro Scheduling and Commitment - Dynamic Hydro Economic Dispatch
EOL	- Economic Operating Level
DOSL	- Danger of Spill Level

Glossary

The following variable notation is used in the thesis:

$Q_{ij,t}$ = flow rate on branch between node i to node j in time increment t

$q_{n,t}$ = water flow rate through unit n in time increment t

$Sq_{ij,t}$ = spill on branch between node i to node j in time increment t

τ_{ij} = branch travel time between node i to node j

$s_{k,t}$ = volume in reservoir k at the end of time increment t

$h_{u,i}$ = upper level reservoir for unit i

$h_{l,i}$ = lower level reservoir for unit i

$P_{n,t}$ = net power generated by unit n in time increment t

D_t = demand in time increment t

$u_{n,t}$ = unit n on/off (0,1) status variable for time increment t

$y_{n,t}$ = unit n start-up variable (0,1) for time increment t

$z_{n,t}$ = unit n shut-down variable (0,1) for time increment t

$I_{i,t}$ = inflow into node i in time increment t. This value is the net of the forecast inflow and scheduled Riparian outlet flow.

Chapter 1

Introduction

A power system is one of the most complex systems in today's civilisation. The cost of running the system and investments in power industry are enormous and any savings or improvement in system operation represent significant benefit. The operation and planning of the system are difficult tasks. They include different aspect which affect security, reliability, quality of supply and cost of running the system. Managing the cost of running the system is one of the biggest challenges for engineers who work in the real system operation environment. As each power system presents a unique combination of loads, generations and electric network, the global objective of minimising the cost of the system while still satisfying all technical requirements, has different limitations dependant on the structure of the system.

The system planning and operation has different time horizons divided into four categories:

- long-term planning
- medium term planning
- short-term scheduling and
- real-time operation.

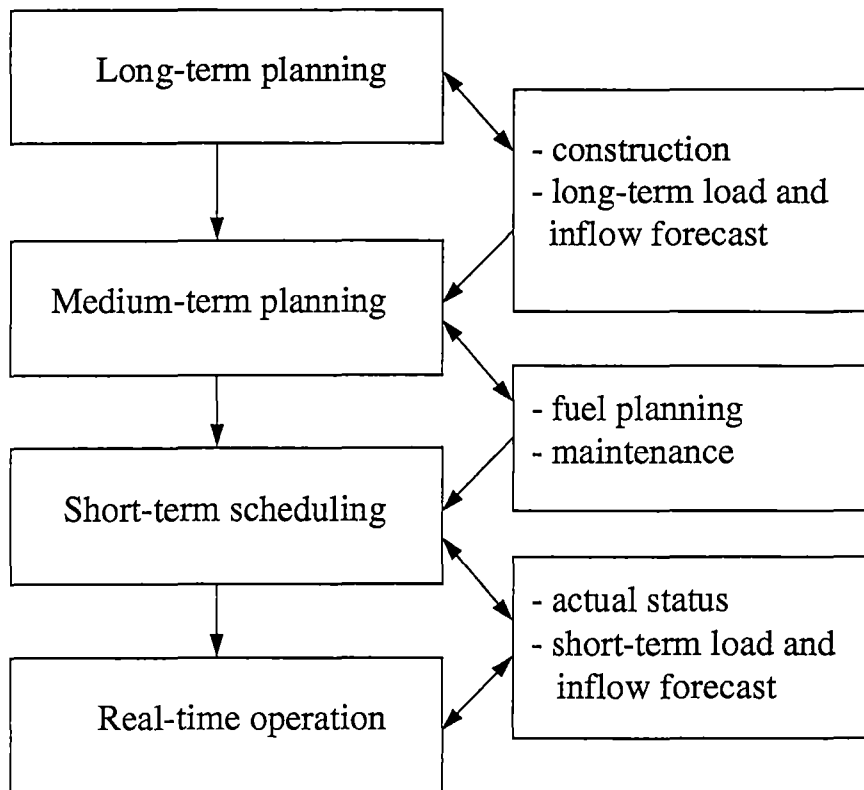

Figure 1.1. Planning hierarchy

Figure 1.1. shows hierarchical structure and connection between the different planning groups.

Long-term planning is the major planning tool to ensure the long term/strategic viability of the power system. It represents strategic study for a period of a few years up to a decade. It ensures that new generation and transmission is built into the system to satisfy anticipated load growth and appropriate plant to support system reserve, frequency regulation and other ancillary services requirements. It is based on the long-term load forecast and long term inflow forecast (for hydroelectric power plants). Today it takes into account solar radiation, wind, waves and geo-thermal energy for non conventional energy resources.

Long term planning results form part of the impact to medium-term planning. Medium term planning represents operational planning for few months up to

few years. It schedules fuel supply and appropriate maintenance planning, based on load prediction, new construction and water management in the system. It produces an optimal plan to ensure the best day to day operation of the system.

Short-term scheduling represents part of system operation planning which optimises predicted resources and supports the best real-time system operation. It is a schedule for up to seven days in advance, including continuous revision and update of the plan. In this chapter, short-term scheduling and the real-time economic dispatch aspect will be further discussed.

The major characteristic of the electric power system is the requirement that generation should match the load at each point in time. This requirement is also known as frequency regulation of the system, as standard frequency determines that generation match the load. Any frequency deviation means that this balance is affected and needs to be corrected.

Load forecast is one of the major uncertainty in system operation planning. Load can be categorised in different ways, but for planning purposes it can be divided into two categories. Bulk or conforming load (usually connected with industrial customers) can be predicted fairly accurately (subject to process interruption), and non-conforming load which changes according to human daily behaviour, season of the year and weather condition. Because optimal generation scheduling and commitment is based on the load forecast, an accurate load forecast allows execution of the prepared optimal generation schedule and appropriate unit commitment which is very important for the slow starting plants with significant start-up costs. Because of inaccuracy in load forecast (and also for plant failure) reserve is imposed on the system (spinning and idle) which increase the cost of system operation. In the case when actual load deviates from predicted, rescheduling needs to be performed or economic

adjustment need to be flexible enough to handle those deviations. This is the reason that load forecast is such an important factor in short-term scheduling and economic dispatch.

Another important factor in planning and operation of the system is the composition of the generators in the system. Based on their cost characteristic and other constraints (like technical minimum of operation, start-up time, ramp rate) different schedules can be produced to minimise cost. The generators can be divided into different categories. The following classification is based on their effect on short-term scheduling and economic dispatch:

- slow start thermal and nuclear plants;
- fast start gas generators;
- run-of-the-river hydroelectric plants;
- hydroelectric plants with storage accumulation;
- non conventional energy sources.

Each of the group has specific characteristics.

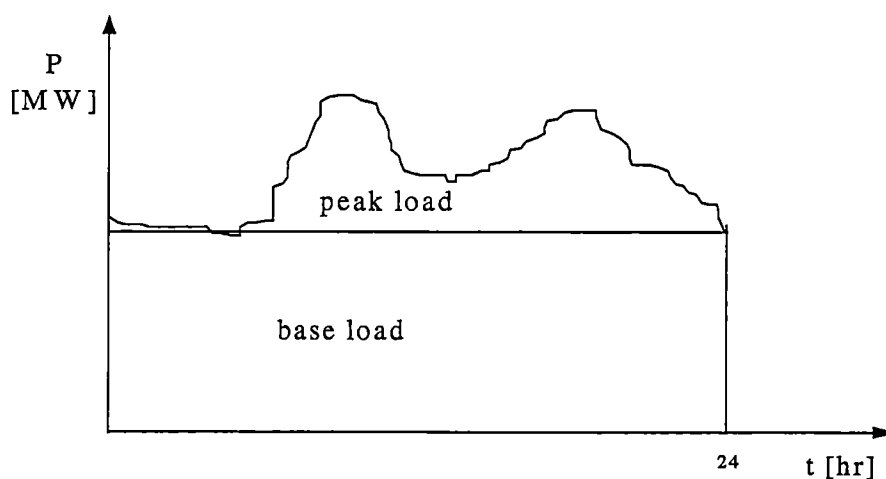

Figure 1.2. A typical load curve

A typical load forecast curve with the simplest division into base load and peak load is shown on figure 1.2. Slow start thermal and nuclear plant are good base load plant with lower operational cost than gas generators and lower investment than hydro plant. Their main limitation is low ramp rate and long start-up process, which means that they can not react to sudden load changes and hence have to be planned for commitment well in advance. They are also connected with significant start-up cost and once when started need to be run for a long, continuous period to spread this cost.

Gas generators are built in areas where hydro resources are not available or their investment cost is less economical than investment in gas turbines. They can respond quickly to system changes and are often used for peak load support, because of their fast start and stop ability. However their operating costs are high.

Hydroelectric power plants are high investment, low operating cost generators which are usually used to respond to real-time load changes because of their start/stop flexibility and good power output response rate. A major problem is that they can be only built where sufficient water flow exists for investment return. Run-of-the-river plant are those with small storages where flexibility is limited by the size of the storage. Hydroelectric power plant with storage accumulation are generators which play the main role in medium term planning and short-term scheduling to ensure that ancillary services requirements are met.

Non conventional sources are not significant in modern power systems, but in the future their influence may increase. The main characteristic of this sources is their stochastic nature and that they can be treated as negative load (with the requirement for forecast) or may be connected with demand management

customers which do not need continuous supply like hot water or off-peak heating.

The scheduling and dispatch problem vary for different compositions of generators in the system. In an all-thermal system, objectives are concentrated on minimising the fuel cost, with respect to all imposed constraints. Mixed hydrothermal system objectives are on maximising the usage of limited low cost hydro resources by substituting the most expensive thermal resources and minimising the fuel cost with respect to both thermal and hydro power plants constraints. For all hydro system the objective is to minimise water usage for the forecast load requirement and respecting all constraints in the system.

As the generation has to reach the load, a set of network constraints needs to be accommodated as well as security and stability constraints, to ensure safe and smooth operation of the system. In many cases other constraints are imposed on the system by other users like multipurpose water storage in the hydro part of the system or gas emission requirement which becomes more important and taken into account through environmental constraints.

Another important aspect of planning and real-time operation is the time limitation for planning and changing planned decisions in real-time. Modern computer equipment and sophisticated programs are available for operators and engineers to support them in system operation.

The main objective of system operation is to provide cheap and high quality energy supply for the customer. The overall cost depends on capital investment, maintenance and operational cost and many other factors, but also on technical decisions made in system planning and operation. Short-term scheduling and economic dispatch are supporting tools to achieve these main objectives.

There are many models and algorithms which try to solve the problems and an overview will be presented in chapter two. A new approach of solving short-term scheduling and real-time economic dispatch as one complex function is presented in this thesis.

1.1. Short-term scheduling

Short-term scheduling is a planning process of the optimal generation units operation for the given short-term period, such that minimum production cost is reached, based on the forecast status of the system and respecting limitations of the system.

Defined in such a way, the short-term scheduling problem represents a stochastic problem, because of uncertainty in the load and inflow forecasts, assessment of non conventional energy production and reliability of generation units and other power system elements. But the size of any short-term schedule makes this a large scale problem and the stochastic approach is not practical. It is also assumed that the most of uncertainty factors in the short-term future period can be predicted with a high degree of accuracy, and that transfers the problem into the deterministic framework.

The short-term scheduling problem is extremely complex . Figure 1.2. shows the global structure of the problem.

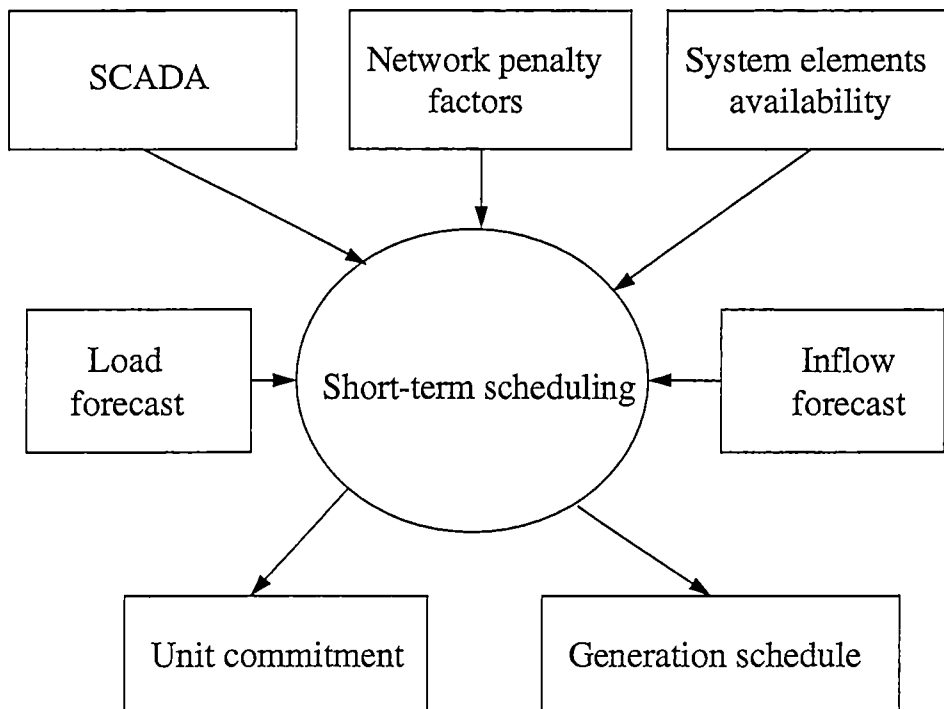

Figure 1.3. Short-term scheduling problem structure

Load forecast curves usually have a cycling nature with a cycle interval of 24 hours. There are different numbers of maxima and minima load curve points for different systems. Load forecast is usually predictable with a reasonable degree of accuracy for the following day. Prediction further into the future is at reduced accuracy. This is the reason why short-term, scheduling in most cases refers to unit operation for the following day and maximum up to seven days in advance. To make the problem practical, load is divided into 24 or 48 time increments which represent half-hourly or hourly load forecast prediction.

Inflow forecast is applicable for systems which consist of hydroelectric power plant. Accuracy of inflow plays an important role for the plant with small storages and short time delay between rainfall and rise of the river level. It affects the accuracy of generation production predictions for these units. There is a similar effect for non conventional energy sources. If the system contains

accumulation reservoirs or pump storages, they can reduce uncertainty by balancing a portion of the planed hydro energy.

Input data into short-term scheduling is the availability of system elements. That takes into account only planned outages. It provides sets of available generators (including availability based on fuel supply) and also network configuration. The major uncertainty is in forced outages which can not be predicted. They are covered by assigning appropriate spinning and idle reserve for the system.

Another set of data, network penalty factors are derived from power flow or optimal power flow studies. They take into account the losses in the network based on power flow. They adjust incremental cost of the operation by applying penalty factors to the generators which will increase transmission losses.

As the schedule has to represent a realistic plan for the generation operation, a set of actual telemetered data needs to be provided as a set of initial conditions. In modern Energy Management Systems this set of data is retrieved through the Supervisory Control and Data Acquisition (SCADA) system.

The output results of short-term scheduling are: proposed unit commitment and schedule level of generation for each time increment of the study period.

The global objective of the short-term scheduling problem is to minimise the cost of energy production. Different models are applied based on type of generator in the system[22]. Generator models are usually connected with the cost of energy production or water usage. A set of global constraints imposed on the scheduling function is:

- power balance constraint;
- required reserve for the system;

- electrical transmission constraints;
- emission constraint and fuel limitation (for thermal units); and
- available water (for hydro units).

Additional constraints which usually depend on the structure of the system are:

- units specific construction constraint (maximum heat storage level, minimum and maximum discharge);
- ramping limits;
- number of starts and stops;
- minimum up and down time;
- maximum participation in reserve;
- maximum power output;
- minimum power output when unit is on-line; and
- water balance constraint (hydro units).

To solve this complex problem various types of optimisation algorithms were used in the past[2,22].

The simplest algorithm is the heuristic algorithm based on a priority list. The main part of this algorithm is ranking the units based on their start-up cost and incremental fuel cost. Today this technique has been slowly transformed into an expert system, by applying a number of sets of rules for ranking the generating units.

Enumeration is another method to solve the unit commitment problem. This method is based on searching all possible combinations and by choosing the best comparative option. The major problem with this method, as with all other searching methods, is the size of the problem. The problem can be solved only partially or for a small size system.

Another well known method based on search techniques is dynamic programming. It is a very popular method in the industry for solving thermal unit commitment, as well as for small hydro cascades. The main problem with this method is the required time to achieve a solution for a practical size of system. There are many variation of this method which improve speed, but none completely solve the problem. Some of them are:

- discrete dynamic programming;
- discrete differential dynamic programming;
- constrained differential dynamic programming;
- incremental dynamic programming;
- dynamic programming successive approximation;
- principle of progressive optimality dynamic programming;
- binary state dynamic programming;
- truncated dynamic programming;
- fuzzy dynamic programming; and
- intelligent dynamic programming.

Linear programming is another simple method. This method can handle large scale problem and an enormous number of constraints, but the model needs to be linear. The main problem with linear programming is the necessity to linearise processes which are non linear. As unit commitment is a non linear process, linear programming is usually not enough alone to solve the problem. Often it is combined with other methods to solve the problem. One way to resolve non linearity is to add dynamic programming in an iterative process with linear programming. The problem is usually divided into sub problems where linear programming finds the optimal solution for the linearised model. Dynamic programming is then used to adjust that solution for the non linear and discontinuity parts of the problem.

Another combination with linear programming is integer programming. This represents a different approach where linear programming problem is solved first and the global non integer optimum is found. After that integer programming is used to define on/off status of the units. The main problem with mixed integer programming is that the search, which like all other search techniques, fails to solve general large scale problem and needs long computational time.

Integer programming is a technique which is based only on on/off decision making.

A very popular method for solving part of the hydro subproblem in a mixed hydro-thermal systems is network flow programming. Network flow structure is similar to the hydrological structure of the system, especially hydro cascades. This algorithm is quick to provide the hydro sub problem solution excluding the on/off decision for the units. The same time consuming problem applies for this algorithm when start/stop behaviour needs to be included.

Lagrangian relaxation is another method which breaks the problem into a master problem and more manageable subproblems which are then solved independently. The Lagrangian multipliers are computed on the master level, then passed to subproblem. The solution of subproblems are then, in iterative approach, passed back to master problem until the iteration gap is reduced to a satisfactory level.

The techniques which are in the development stage are expert systems and artificial neural networks. Expert systems are based on the knowledge of experienced power system operators and very often represent an interactive tool

for the operator. Artificial Neural Networks are based on a database set of load and predefined economic unit commitments. The main part of the process is off-line training which will supply sufficient information about economic operation to solve the problem.

These are the general methods and to find a particular solution modifications are often required or a special search technique is used. Until mathematical methods and computer technology are improved to the level where a global problem can be solved by any of the optimisation techniques, effort will be put into of line preparation and using heuristic expert experience which is the area of combining expert system and artificial neural networks with some of the mathematical optimisation techniques to achieve the best results in short-term scheduling.

Another important aspect of short-term scheduling is execution of the plan in a real system. It is important that the scheduling plan has the flexibility to be adjusted during a real-time operation for all the inaccuracies in the prediction. This is done through real-time economic dispatch where the actual data is available and the initial scheduling plan can be adjusted.

When deviation from the plan is significant, economic dispatch may not be able to follow the optimisation set in the planning process. For those systems where the predictions are not reliable, rescheduling needs to be consider as an option to ensure that the plan passed to economic dispatch can be supported and planned optimisation achieved.

1.2. Real-time economic dispatch

Real-time economic dispatch is a process of generation allocation to the on-line units in a way that load may be supplied entirely and in the most economic manner. It also represents the economic adjustment connection between short-term planned operation and actual real-time control of the system. It has to take into account the actual status of the system including transmission network and to respect all constraints which affect operation of the system.

The main system requirement to maintain nominal frequency is enforced through primary and secondary regulation of the frequency. Economic dispatch represents economical generation allocation readjustment after frequency regulation. In some literature[4] economic dispatch based on optimal power flow is referred to as tertiary regulation. The primary regulation of the system is provided by the generator governors. This is the process where individual governors, according to their construction and setting, respond to the changes in the system frequency and allow the system to be return to the new stable frequency point. However this frequency point is not the nominal frequency point and automatic generation control represents the secondary regulation to change generation to the level which will produce nominal frequency. Secondary regulation is a centralised function which distributes required power output back to the assign individual governors. Movement of machine power output in automatic generation control is based on regulation and allocation participation factors defined by the characteristics of the specific units and their suitability for secondary regulation, rather than in optimal economic manner. Economic dispatch is the process to readjust those movement in the most efficient way. If the only requirement is to maintain nominal frequency, this type of automatic generation control operation is known as flat frequency

regulation. In isolated systems usually time error correction is added to the automatic generation control function.

The most common economic dispatch is based on the incremental cost of the on-line units. This method is also known as the “coordination equation” method derived from Lagrangian multiplier. It is an approach where the units with the lowest incremental cost is first to increase power and units with the highest incremental cost are the first to reduce power output subject to set of constraints.

In the interconnected system automatic generation control has a role to maintain predefined energy transfer between interconnections. In this case economic dispatch has the role to adjust generators in the area to ensure constant power exchange between interconnected areas. This is similar to the flat frequency with the exception that governors in both interconnected areas react in primary regulation. The power output is then reallocated on generators in secondary regulation and economic dispatch to ensure both nominal frequency in the region and constant interconnection flow.

Until now only cost of fuel has been discussed and minimisation of that cost. However there are other cost which may be incurred by transmission losses in the system. Transmission costs are incurred both by active and reactive power transfer. Minimising the transmission losses are one of the added objective to the economic dispatch. In systems where reactive power regulation comes from capacitors banks and regulation transformers, economic dispatch usually takes into account only active losses. But for systems where portion of the reactive regulation is provided by generators, both reactive and active power can be taken into account. This is the method of utilising optimal load flow for the purpose of economic dispatch. There are many other factors and constraints

which can be taken into economic dispatch consideration. Some of them are security and environmental constraints.

Most of the dispatches represent static economic dispatch, because they consider operating cost only in one steady-state isolated interval. In many cases, especially in hydro systems, it may cause non optimal trajectory. Dynamic economic dispatch is dispatch which includes load forecasted to optimise trajectory rather than one step optimisation. In the case of economic dispatch for the hydro part of the system, the trajectory of target levels needs to be followed according to the schedule to avoid emptying small ponds or increase risk of spill. It is because hydrological processes present slow change compared to electrical processes. It is useful to have dynamic dispatch where appropriate electric power output changes can be used to influence slower hydrological changes.

They are many techniques[4] used in economic dispatch including techniques used for optimal power flow. All these techniques have to provide quick solution as one of the most important characteristics of economic dispatch is its closed loop control with the real power system through AGC. The model of the system is very complex and includes a full set of constraints, such as: minimum and maximum generation, ramp rates, disallowed operation region and etc. In the case of a hydro unit the problem can be even more complex as the hydrological constraint connected with operation of hydro plant has to be taken into account, such as: minimum discharge, reservoir target levels and allowed draw/fill of the reservoir and all limitation of the waterflow paths. Appropriate modeling is necessary, because any error in the results of the economic dispatch can produce disturbances in the system.

Both short-term scheduling and economic dispatch effect operating cost of the system, but also security, reliability and quality of supply. These processes represent the most important aspects in day to day operation of the power system. They need to be automated because they require huge man power for manual operation, and for the same reason it is difficult to adjust them according to the changes in the system. Today's approaches do not solve the global problem, but they present useful tools for system operators and can be used to support operator decisions. Special techniques can be and they are apply in real power systems to solve short-term scheduling and real-time economic dispatch problem.

Chapter 2

Review of Hydro Power Plants Optimisation

2.1. Introduction

The optimal operation of the power system has been investigated since early days of power systems. Special attention has been given to the optimal generation schedule, because significant savings can be achieved in this area. As pure hydro systems are not common, treatment of hydro in many cases has been connected with thermal operation and thermal fuel cost. Today when an open electricity market is becoming a reality in many countries, and a decentralisation of the power industry is representing the main trend, the independent hydro generation will become a reality and the necessity for optimisation of the pure hydro system.

Operation of the hydro system can be divided into three parts:

- long term operation (few years up to few decades in advance)
- mid-term operation (few weeks up to two years in advance)
- short-term and real-time (daily up to one week in advance)

Assessing the optimal operation of any one of these components should include

an understanding of the requirements of the other component as the objectives and constraints may not be the same for different time horizons.

The most important part of any optimisation is the objective and constraints imposed on the optimisation. In the following sections, an optimisation will be discussed as the unconstrained optimisation, constrained optimisation in the isolated system condition and optimisation with other generation available (market or semi-market condition).

Long-term assessment of hydro system operation, also known as system rating, is a simulation process. The simulation is done for the long term period in the future (up to few decades) and is usually done only for pure hydro or mostly hydro systems to determine probable energy production for the selected period. The simulation process is extremely complicated as the number of the possible combinations increase rapidly with the complexity of the hydro scheme and imposed constraints.

The simplest assumption is an unconstrained system. The assumption for the objective (optimal) is that maximum amount of energy for available water need to be produced. In this case, each cascade can be treated separately, which breaks the problem into more manageable subproblems. The overall result are achieved by summation of the optimal operation of subproblems. In that case subproblem can be solved by set of repeated rule based simulation (in this case even with optimisation) which will give the maximum energy production.

However all real systems have different constraints which need to be modelled, like:

- power balance constraint
- network constraints

- other users requirements
- reliability standard constraint

By introducing the power balance constraint and network constraint we effectively require an integrated simulation of whole system. Even if we assume that some rules based simulation can bring us to reasonable solution for those two constraints, reliability constraint causes the major problem for assessment.

Reliability constraint is based on the inflow probability and chosen set of data for synthetic inflow data and allowed percentage based failure of the system. There are few major potential problems with long term simulation:

- The amount of historical data necessary to chose appropriate synthetic inflow data. Only if the same output data can be achieved with different sets of historical data then the assumption can be made that we have enough data (full cycle) to model appropriate synthetic data. Otherwise, in the case of different output results, interpretation of data, may produce variety of conclusions, especially in connection with percentage failure;
- Reliability operation of the system require a reserve in mid term storages to avoid failure of the system during dry years, which reduce the rating of the system;
- Difficulty in choosing a reliability factor that is appropriate for the losses incurred by system failure;
- Actual inflow may change as the global weather changes and it also may change in microclimate as the new artificial lake is built.

In the market or semi-market environment reliability does not represent the constraint for the generator, because market operator takes reliability responsibility. The unconstrained simulation can be used for system rating and post simulation analysis can be applied to determine system rating now required for level of long term contracts. Flexibility of the system is increased as opportunity for short term contracts (few years) exist based on actual storage levels.

The mid-term optimal operation (also referenced as long term optimal operation) represents the optimal operation for the future period up to two years in advance. This optimisation is the most important optimisation task as the benefit of the optimal operation can provide the most returns.

The whole analysis described in long term can be applied to mid-term with taking into account actual storage level and actual maintenance planning. In the long term optimisation system rating is treated as constraints for large reservoir levels to ensure long term reliable operation of the system.

The objective of mid-term optimisation is to optimise operation of the medium storages (more than a week) based on actual levels and maintenance plan (it may also produce optimal maintenance plan based on mid-term release strategy) and balance of long term storages (more than one year accumulation). It has more flexibility than system rating, because the time horizon is only one year and actual storage level on the beginning of the study period may be significant. The analysis of spill losses and efficient use of water from medium term storages plays the most important part as the actual storage levels has been incorporated.

This optimisation also has the major impact on the short-term optimisation as it

produce release policy for medium term storages and directly affect short-term and real-time operation.

The main difference between mid(long)-term optimisation and short-term optimisation is in deterministic approach for short-term optimisation.

Short-term optimisation objective is to maximise energy production based on mid-term optimisation release, which means the most efficient use of available water. That is enforced in the real-time operation based on actual load and inflow.

It is important to understand that short-term optimisation represent constraint optimisation, with full set of constraints, which means that optimisation can be done only inside those constraints. The major constraint represent mid term optimisation which define available water for each power station.

The short-term optimisation present an operational plan which is adjusted by hydro economic dispatch in real-time operation.

2.2. An overview of the methods

An overview of reservoir management and generation scheduling and dispatch optimisation are given by S. Yakowitz [1] in 1982, W.W-G. Yeh [2] in 1985, A.I Cohen and V.R Sherkat [3] in 1987 and B.H.Chowdhury and S.Rahman [4] in 1990. They presented an overview of different optimisation techniques which have been used for the optimal short term scheduling and real-time economic dispatch. The main optimisation methods can be divided into the following categories:

- heuristic methods;

- linear programming;
- dynamic programming;
- non-linear programming;
- network flow method;
- expert systems and artificial neural network.

Dynamic programming and different modifications of dynamic programming have been very popular techniques as the only one which can handle many of the problems connected with hydro power system: unit commitment, non-linearity and non convexity. The size of the problem is so large that today's computer can solve only small problems in reasonable time. Different dynamic programming methods listed in reference [1] were improving speed of search, but they did not manage to fully resolve the size of the problem. Even today's computers are limited to a five reservoir problem, and only with different approximations can be used for more than five reservoirs[5]. The main conclusion for dynamic programming techniques is that they can be implemented on a small cascade [21], but they cannot be used for large systems.

Non linear programming techniques [6] were not widely used, because of difficulties in handling unit commitment, non-convexity and the most important connection between intervals and water travel time.

Network flow is probably the most popular method for scheduling the hydro part in mixed hydrothermal scheduling process [7,8,9,10,11]. The network flow algorithm is appropriate because of the network configuration of hydro power plants. It is essentially a linear programming algorithm with non linear objective function. This algorithm is computationally superior compared to all other algorithms. The major problem with network flow algorithm is the handling of

non network constraints connected with power constraints, head variation and unit start-up.

Very similar to network flow is linear programming [12,13], but it is more used in the pure hydro system, as it concentrates on more sophisticated hydro optimisation. The advantage of this algorithm is easy handling of any additional constraint, that invoke cost in computational time. Linear programming still uses node and arcs network techniques to build the model. The major problem with this technique is that it cannot treat minimum power output or hydro unit commitment. Some of the authors [12] assume that start up cost of hydro units are low and so can be ignored, others believe that costs can be significant [14].

A major problem for both network flow and linear programming is that hydro units presented with linear models have the same efficiency operation from zero MW to maximum efficiency MW, because of the nature of the efficiency point to represent the tangent on the p/q curve which passes through zero. This is represented in figure 2.1. Any linear programming techniques will calculate that operation between zero and maximum efficiency represent the same use of water per MW. On figure 2.2 are represented real MW/cumec curve and MW/cumec curve for linear approximation.

As the power production, in some form, is included in the objective function, discrepancy will always exist between real and calculated efficiency. Some authors tried to overcome this problem [10], but that affect computational time performance. Linear model treatment of operation below maximum efficiency, and start up cost are possible but difficult; however these aspects are important in the optimisation of the hydro system.

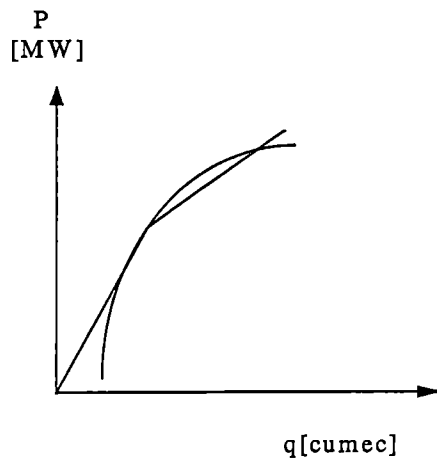

Figure 2.1 : P/q curve

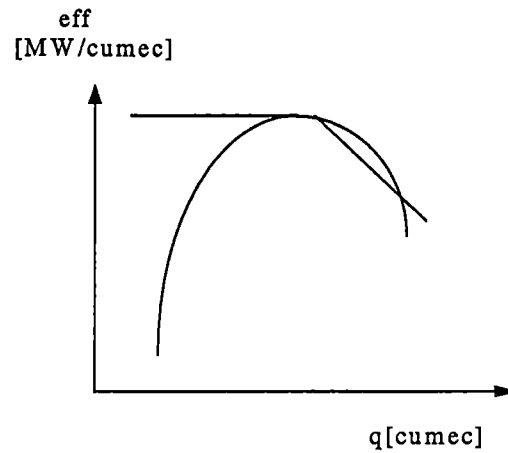

Figure 2.2: eff/q curve

Expert system techniques are predominantly used in thermal systems [22]. Some recent papers introduce artificial neural network in hydro system [15]. They are definitely very fast and efficient, but a major problem is that they do not represent real optimisation techniques as the solution depends on the historical data and learning pattern. Heuristic methods have been used in the past and they can be valuable support, but their ability to achieve an optimum result is not easy to prove. Development and research will be significant in the future in this area [30] and some techniques will probably find a place in interactive operator decision support.

Based on the preceding overview the following characteristics correspond to possible optimisation techniques of hydroelectric power system:

- hydro model is a network type problem with additional not network constraint - network flow and linear programming are ideal for this formulation with very good computational performance, but has serious problems in neglecting the non-linear part of the p/q curve, especially in the area from zero to maximum efficiency.

- It is non-linear problem - DP and non-linear techniques can handle this, but it affects computation time.
- Start-up costs are often neglected and units leave to start and stop as continuous process

There are other important characteristics of an hydroelectric power system:

- Operation of the power system is connected with uncertainties in inflow and load prediction and dynamic adjustment is necessary [18,19].
- Coordination of water usage is very important to avoid shortages or unnecessary spill [17].

2.3. A new approach

There are four major factors which affect optimal operation of the hydro system:

- Operation at maximum efficient point;
- Operation at the best head;
- Start up cost;
- Target level achievement (connected with mid and long term optimal operation).

By monitoring the operation of hydro systems, especially those with significant number of run-of-river or weekly storages, the most important factor in operation are uncertainty of predictions. Hydro plants are usually those which follow the load changes, and any load uncertainty will affect hydro production. Inflow is also basic fuel for hydro - any change in inflow will require a revised plan to meet target levels. That prompted the implementation of the coordinated approach algorithm [20] which will constantly update a schedule based on

actual data which will take care of uncertainty in optimal manner. The algorithm is functionally divided into three parts and illustrated in figure 2.3.

The Energy Allocation (EA) and Generation Scheduling (GS) functions execute on a daily basis for the next day and up to 8 future days. Rescheduling is done on the half hour basis. Dynamic Hydro Economic Dispatch (DHED) executes for a period of up to 4 hours every five minutes.

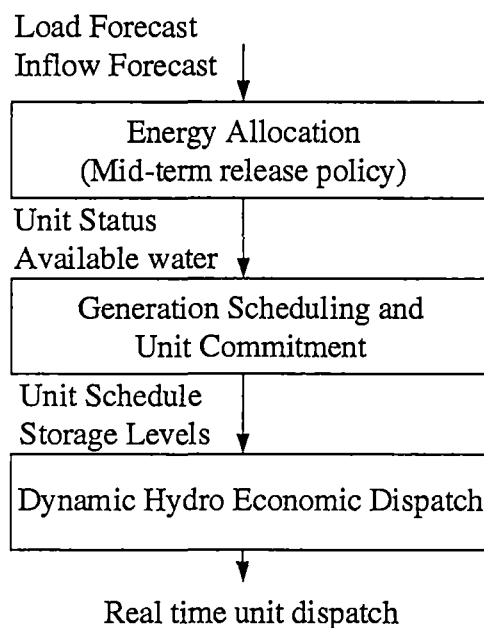

Figure 2.3: Functional Hierarchy

EA is a storage policy interpreter and represents set of rules to define water release. It can be understood as tool to transfer mid-term optimisation requirements into short-term optimisation constraint. GS is scheduling function which uses mixed integer linear programming to solve the scheduling and unit commitment problem. GS is closely coupled with DHED to ensure better prediction uncertainty treatment. DHED receives real-time data and has a look ahead algorithm. It uses linear programming techniques and heuristic search for better resolution of unit commitment.

The flow chart of operation of these functions is shown in figure 2.4.

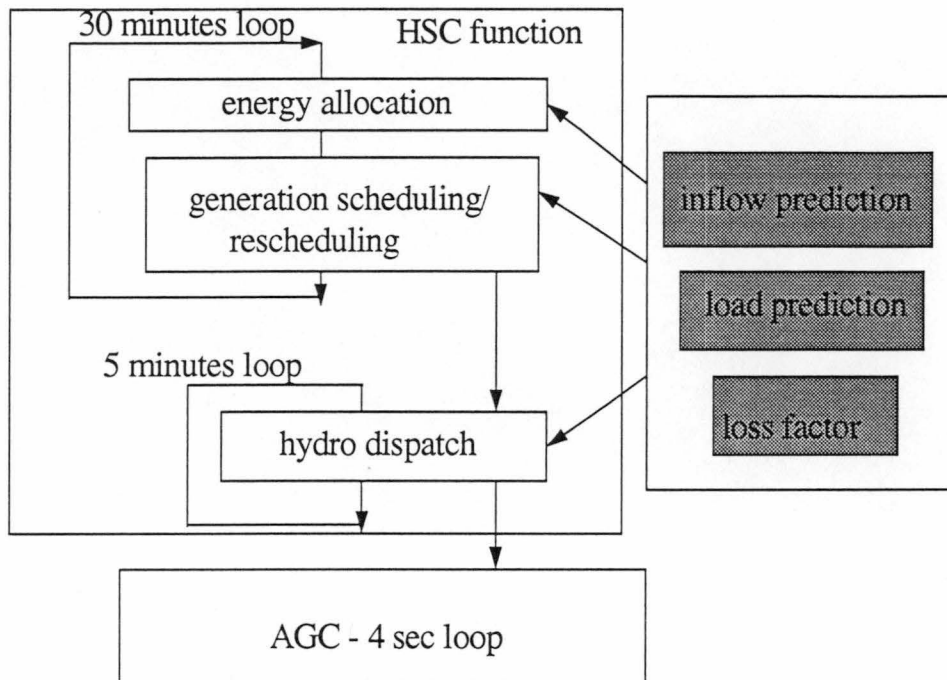

Figure 2.4: Flow chart of the main functions

GS function assumes maximum efficiency operation of machines and also ensures that target levels will be satisfied. It also schedules start-up of the machines so that minimum costs are incurred and optimises head. The economic dispatch has the major part in real-time scheduling algorithm. It can achieve optimisation based on maximum efficiency operation and target level achievement by following the reservoir target levels set by the GS function. Another important feature is that the allocation of water is performed continuously according to real-time updated load and inflow prediction.

The major components of the new algorithm are:

- real-time scheduling which is performed through constant rescheduling and dynamic economic dispatch;
- mixed integer linear programming techniques implementation;

- full hydro model including head variation and start-up costs.

The advantages of the algorithm compare to other algorithms are:

- the optimal solution is less dependent on the uncertainty from inflow and load prediction;
- real-time planning and dispatch can be achieved by introducing a coordinated approach;
- units start-up costs and head variation is taken into account.

Chapter 3

Optimisation in a Pure Hydro System and Independent Hydro Generation in Open Electricity Market

3.1. Introduction

Optimisation of the generation production in a pure hydro system has to incorporate the specific characteristics of a hydro system:

- operating cost is low;
- fuel supply is dependent on accuracy of prediction and it is not controllable. The fuel is not equally spread over the year. The fuel can be accumulated in the mid-term and long-term storages;
- the system is flexible for start up and shut down;
- other water users may affect the system.

In regards to these characteristics, optimisation of the hydro system should contain the following components:

- close coordination with mid-term and long-term planning (fuel resource planning) and dynamic prediction update. It increases controllability of the fuel supply and decreases dependence on prediction;

- constraint optimisation with respect to other users requirements.

The figure 3.1. represents general diagram for hydro optimisation process.

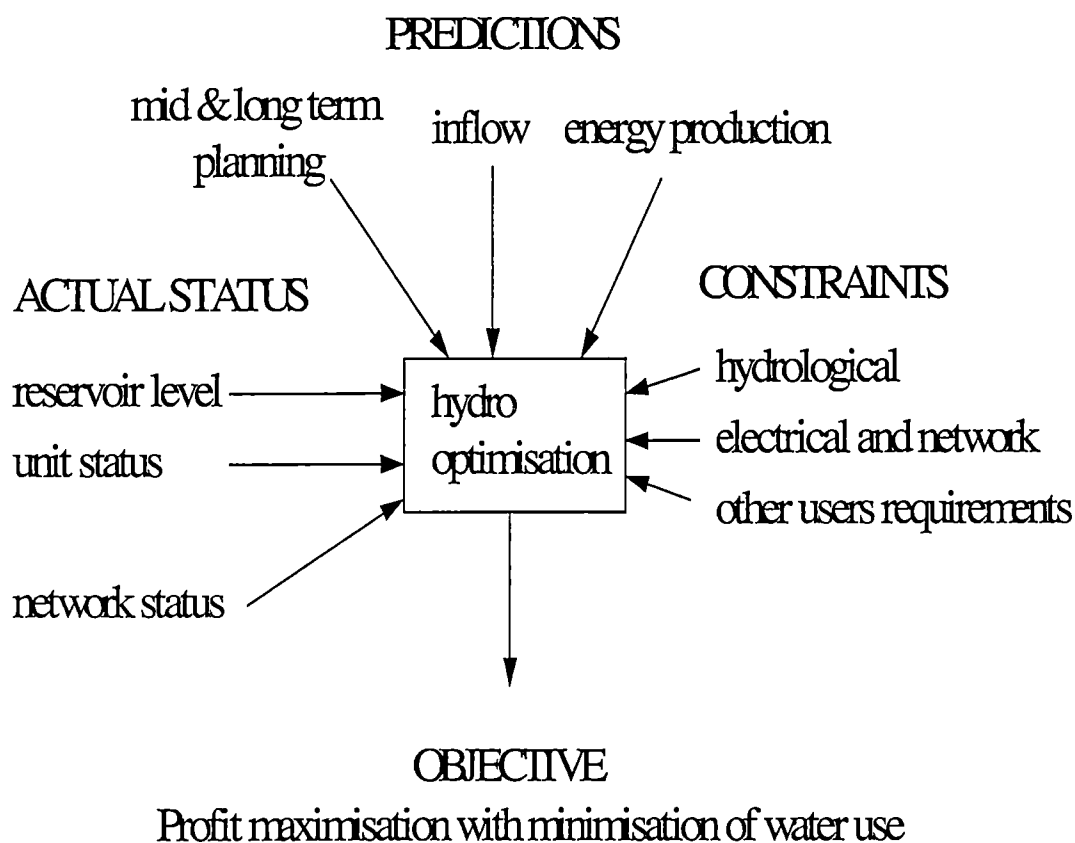

Figure 3.1: Hydro optimisation process

Actual status and constraints are different for each hydro system, but can be modelled in the same manner with mixed integer linear programming.

Table 3.2. represent a comparison of hydro systems in three different optimisation regimes in regards to objective function and prediction processes.

	pure hydro system	independent hydro generator in comp. electricity market	hydro generator in the mixed hydrothermal system
objective function			
	satisfying energy requirements by min. use of water	maximise the profit based on market price	minimise thermal cost based on available water
prediction input in scheduling			
mid -term planning input	water availability, water value,priority release	water availability, water value,priority release	water availability, water value,priority release
inflow	deterministic	deterministic	deterministic
load	deterministic	deterministic	deterministic
prediction based on			
mid-term planning	long term viability of the system	actual and future market price and long term viability of the system	usage of hydro in coordination with thermal plants availability and cost
load	customer requirements	bidding strategy	customer require. and thermal planning

Table 3.2. : Comparison of different scheduling environments

The table shows that differences exist only in the objective function and how the predictions are prepared. The objective function will be discussed later in the mathematical model part. The following two sections discuss the long/mid-term planning and load prediction aspects.

3.2. Effect of the long-term and mid-term planning on real-time scheduling

From the real-time short-term hydro scheduling aspect, mid-term and long-term planning policies represent, an input which ensures appropriate release from medium and major storages in the system.

The following elements can be provided as an output of the mid-term policy:

- release priority;
- expected value of MW/cumec to be achieved from the medium/major storage and all downstream storages for storage levels;
- relative water value for the full range of storage level.

A release priority from the medium and major storages depends on the long term strategy and fill/empty cycle of storages.

The expected value is a supplement of release priority and is usually connected with the cascade hydro plants with a medium or major storages the headwater of the cascade. This value takes into account an actual inflow into downstream run-of-river stations. In the case of a high inflow into run-of-river storage can be skipped from release priority to avoid spill on downstream station and inefficient

use of stored water. This expected value is changeable and depends on the level in the storage and power system requirements for hydro generation. If the level is low then the high value is to be achieved on the cascade. The maximum expected value is the sum of maximum efficiency point of the whole cascade. As the level increases the expected value is lower. At the time when the level approaches to the full supply level, it becomes equal to the value of the headwater storage power station above.

A relative water value has a different meaning for different hydro system environments. In a pure hydro system this value is only a signal of current status of storages and can trigger analysis for possible energy rationing or additional energy support to ensure long-term viability of the system.

For an independent hydro generator, it gives the price which generator is willing to accept on the spot market.

For mixed hydrothermal power systems, it gives comparative price with thermal operating cost to ensure long term hydro share of generation.

3.3. Effect of the load and inflow prediction on real-time scheduling

A load prediction in a pure hydro system is based on the customer load demand. For the independent hydro generator, it is based on the prediction of a share of the generation based on customer demand and expected spot price on the market. In a hydrothermal system it is the hydro share of generation based on customer

demand, thermal units availability and operating cost. In the hydro scheduling function load is treated deterministically. It is also important to take into account that hydro generation often takes a role of regulating reserve in the system, which means that load prediction in the case of hydro is very uncertain.

Inflow prediction is also an important factor, especially in those systems where significant energy production comes from run-of-river power stations. Any change in inflow will require increase/decrease in storage station release.

These two uncertainties are very important in the decision making processes, especially to track target levels of storages, minimise the number of start-up/shut downs, maximise the head and minimise the deviation from maximum efficiency.

This is the most important reason why the real - time hydro scheduling concept is developed with the main features of constant rescheduling based on real time data, dynamic dispatch and close coordination between scheduling and dispatch.

Chapter 4

Algorithm for the Real-time Short-term Hydro Scheduling

4.1. Introduction

The Real - Time Hydro Scheduling and Commitment (RTHSC) function is used to optimally schedule and dispatch the generating units.

This scheduling is performed in three phases:

1. RTHSC - EA. The water release for each station is determined using the rules based simulation based on mid-term policy.
2. RTHSC - GS. An optimal half-hourly generation schedule is determined to meet the water release determined by the EA.
3. RTHSC - DHED. An optimal generation schedule is determined based on real-time data.

The RTHSC function determines the unit generation schedule and dispatch which maximises the electrical energy produced from the water released according to the storage policy while meeting all operational constraints.

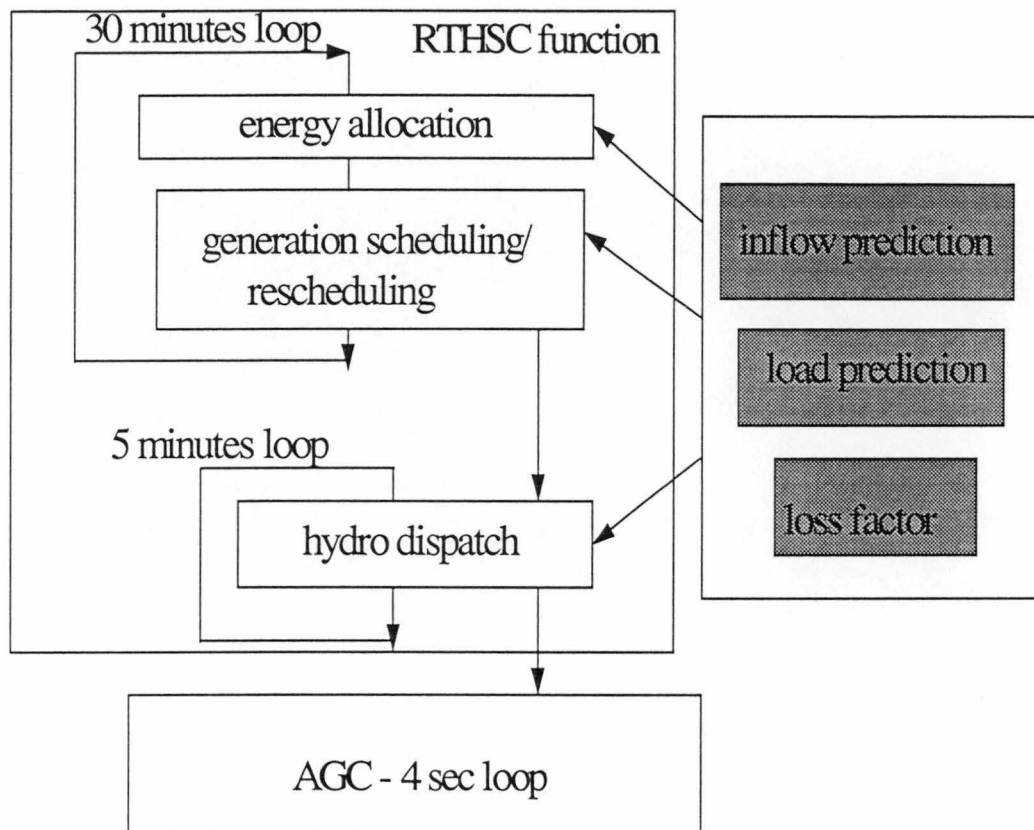

Figure 4.1: Flow chart of the main functions

The input data for the RTHSC function includes the half-hourly system load forecast, the reservoir inflows from the inflow forecast and the generating unit maintenance schedule from the outage plan. Other input data includes initial and historical state of generating units, reservoir levels, river flows and storage release policy data in the form of storage release priorities, minimum expected values and reservoir target levels.

RTHSC first determines the scheduled water release using the storage release priorities, minimum expected values and reservoir target levels from the mid-term plan with the forecast natural inflows and energy demand.

RTHSC then utilises a detailed mathematical model of the hydrological system which incorporates models of the unit power/turbine flow/head characteristics to solve for the generating unit schedule which maximises the electrical energy produced by the released water from the storages and the natural inflows.

The RTHSC-DHED is performed by allocating the desired hydro generation so that the reservoir target levels obtained from a previously executed GS solution are respected. The DHED function ensures that the hydro units are dispatched at the theoretical maximum efficiency point for the real-time telemetered head level. It also refines unit commitment/decommitment based on real-time load and inflow data.

The RTHSC GS and DHED functions share the same hydrological models and all three functions share the same database.

4.2. Energy allocation function

The first step is to define the water release and energy allocation for each station using the rules from the mid-term plan.

The following factors are used to determine the release of water from the medium and major storages:

1. Release priority and Minimum Expected Value. Medium and major storages are given a priority order based on the long-term storage strategy. In addition, a Minimum Expected Value in MW/cumec can be applied to a medium or major storage release for a given reservoir operating level. Water

is then released from storage according to a user-specified priority, provided that the actual incremental water value is greater than or equal to the Minimum Expected Value for the reservoir operating level. The incremental value of the water is determined by the downstream inflow conditions and the availability of the plant.

2. Economic Operating Levels (EOL) are target levels which may be set for any storage for any period during the study. If these values are set for a particular storage, water will be released so that the reservoir level remains at or above these levels at the end of the study. These levels are derived from long/mid term planning adjusted for actual system conditions.
3. Specific rules may be applied for some catchments and power stations based on other constraints in the system.

The Energy Allocation is performed using a Hydro Simulator (HS) algorithm to simulate the downstream flows and energy output while iteratively releasing water from the storages until the daily energy requirement is met. The algorithm for performing the Energy Allocation is illustrated in the general flow chart in Figure 4.2.

Initially the medium storage releases are set to zero, unless a storage station is spilling, in which case the release is set to use as much of the spill flow as possible. The Hydro Simulator is solved to determine the energy output from the run-of-river stations.

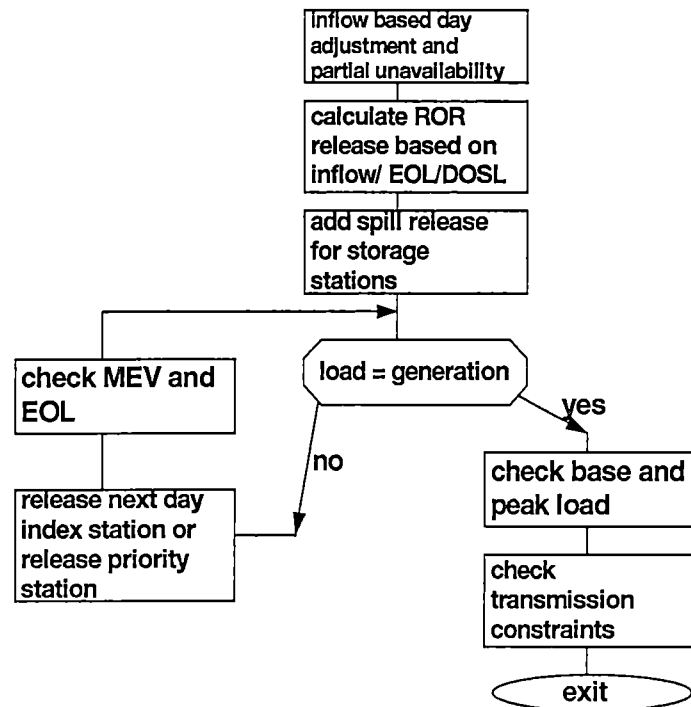

Figure 4.2 : Energy Allocation Flow Chart

The energy production from the station is calculated as follows:

1. If the average scheduled water flow is less than the maximum efficiency discharge, the number of hours of generation at maximum efficiency is calculated and the energy production is calculated using the maximum efficiency conversion factors.
2. If the average scheduled water flow is greater than maximum efficiency and the reservoir levels, natural inflows and upstream flows are such that the reservoir will not reach danger of spill level within the study period, the station is operated at maximum efficiency for the whole period and the energy production is calculated using the maximum efficiency conversion factors.

3. If the average water flow is greater than the maximum efficiency and the natural inflows and upstream flows are such that they will cause the reservoir to reach danger of spill level within the study period, the station is operated between maximum efficiency and full gate to hold the reservoir at DOSL if possible. If the reservoir cannot be held below the DOSL at full gate output, the station is run at full-gate and the excess water volume above full supply level is spilled. In this case, the energy is calculated using the conversion factors derived from the non-linear unit input/output curve for the flow level.

If the generated energy is insufficient to satisfy the load, water is released from the medium storages according to the storage policy. Prior to releasing the water, incremental water value curves in MW/cumec are constructed for each catchment. These incremental water value curves are constructed by adding the incremental water value curves for the individual units in the cascade. Two types of stations are considered in the incremental water value calculation; “following” stations and stations planned for maximum efficiency.

“Following” stations are run-of river stations with small reservoirs. They are operated so that their reservoir remains at a constant level; all water from natural inflows and upstream stations must be utilised. These stations may operate at any output level required to maintain constant reservoir level. In the calculation of incremental water value the full non-linear unit efficiency curve is used.

Stations planned for maximum efficiency are operated at maximum efficiency by scheduling them for a number of hours required to utilise their scheduled water usage at maximum efficiency. In the calculation of the incremental water value, a linear segment is constructed from zero to maximum efficiency and the non-linear characteristic is used above maximum efficiency.

The catchment incremental water value has to exceed the minimum expected value defined by mid-term policy to allow water release from the headwater storage.

These unit incremental water value curves are illustrated in Figures 4.3a and 4.3b.

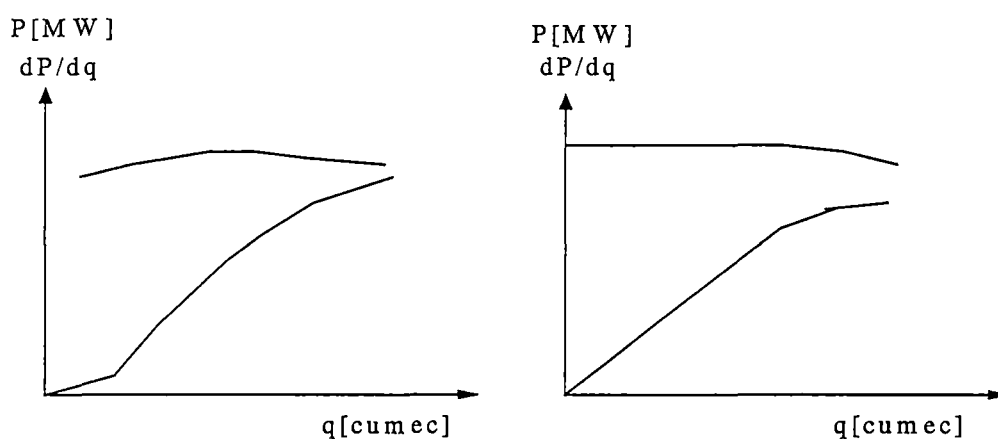

Figure 4.3.: Incremental curves

(a): Incremental curve
for follow station

(b): Incremental curve
for other stations

The system load duration curve is used to determine whether or not there is sufficient generation to meet the system peak. If there is not sufficient generation, the storage release policies are adjusted.

In addition, the load duration curve is used to ensure that the generation will balance the base load for the study period. If there is a surplus of generation, the last committed storage station is backed off until the base load energy demand is satisfied.

In some cases, under the heavy inflow or transmission constrained conditions, it may not be possible to back-off storage releases above to meet power balance or

transmission constraints. In these cases, it is normally necessary to spill at certain stations in order to meet the constraints.

This algorithm may be executed for up to 192 hours with station energies being allocated on a 24 hour basis. Eight 24 hour time steps will be used. If spill or operation away from maximum efficiency would occur in one of these time periods due to increased inflows in one of the later days, the algorithm will attempt to allocate more hours of maximum efficiency operation in one of the previous or later days.

The results of the storage policy Energy Allocation solution are used by the second phase of the HSC function to develop an hourly or half-hourly generation schedule that meets the requirements of the storage policy.

The Energy Allocation phase provides the following information to the Generation Scheduling phase:

1. Scheduled Water Releases. For each station, a maximum and minimum storage release in $\text{m}^3/\text{sec-hours}$ is provided to be used as a constraint in the Generation Scheduling solution, as well as canals/tunnels.
2. Unit Hours of Operation. For each unit, the number of hours of operation is specified for the study period. Those units with zero operation hours during the study period are given an off-line status and are not considered as an optimisation variable by the second phase. Those units operating at all time increments of the study are given "must-run" status and also are not considered as optimisation variables in the second phase. The remaining units' status are considered as optimisation variables and their hours of operation are constrained to that specified by the Energy Allocation solution.

3. Reservoir Constraints and Target Levels. The reservoir levels computed as part of the Energy Allocation solution may be used as constraints in the Generation Scheduling phase of the HSC solution.

4.3. Generation scheduling function

The Energy Allocation solution described in the previous section provides the total water discharge for each plant for the study period. These water discharges are translated into number of hours of maximum efficiency operation for each unit.

In the Energy Allocation, some plants are held off-line throughout the study while others will remain on-line for the entire study period. These units can be held on-line and their commitment status does not need to be considered as a variable in the GS solution.

The problem to be solved in this phase of the GS solution is to find a half-hourly generation schedule which maximises the electrical energy produced by the hydro system while meeting the water release constraints from the Energy Allocation solution in accordance with the mid-term policy.

HSC incorporates a hydrological network model, it is established by assigning node numbers to reservoirs and other intermediate points in the network and flow branches are specified by assigning from and to nodes to the branches. Some branches may be spillways in which their flow is a function of the level of the reservoir above the spill level. Other branches may be generating units

where the power generated is a function of the flow through the branch. The hydro model is completely general and any number of parallel branches may be connected between two nodes. Time delays may be applied to any branch in the model.

A typical hydro catchment configuration is shown in Figure 4.4.

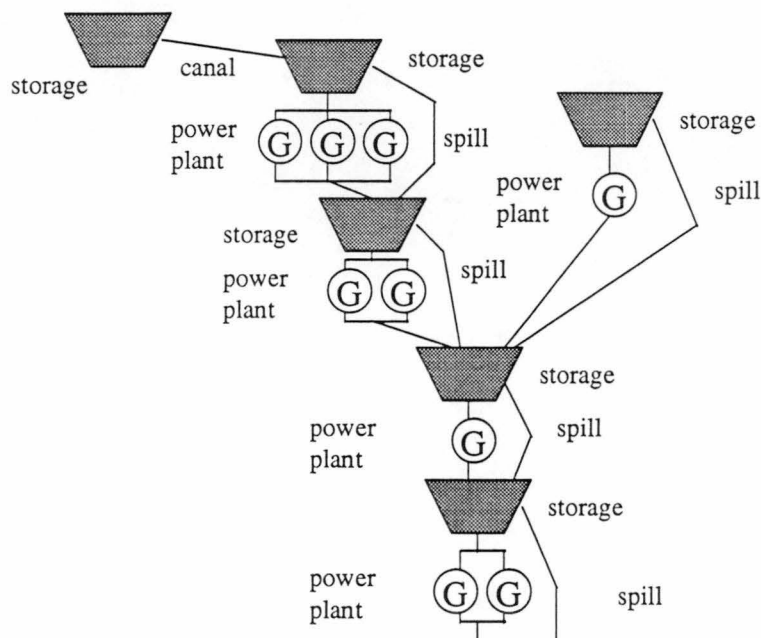

Figure 4.4: Typical reservoir model

The main GS problem is solved using Mixed Integer Linear Programming (MILP). MILP is used rather than conventional linear programming so that the integer terms corresponding to start up may be included.

The problem is converted into a set of constraint rows and variable columns using a sparse constraint matrix format, which can then be supplied to the MILP package for solution. Columns in the formulation are branch flows, reservoir volumes, unit status and start-up/shutdown variables, piecewise linear variable

weights for unit generations, spill flows and reservoir target level penalty functions. A set of columns with upper and lower limits is required for each time increment. Those columns which are integer variables require additional information indicating that they are zero-one variables. Upper and lower limits

are also specified for each row for each time increment. The objective function is incorporated by specifying objective function coefficients for each column.

Outputs of GS are used in DHED as the optimal solution to be followed. GS supplies DHED with the following information:

- Reservoir target elevations for each time increment based on the GS solved reservoir elevation
- Unit start-up/shutdown schedules
- Units operating modes

4.4. Dynamic hydro economic dispatch function

The Dynamic Hydro Economic Dispatch (DHED) function presents a bridge between AGC and GS functions to provide real-time dispatch of hydro units so that the schedules generated by the GS function may be implemented using the AGC subsystem.

The DHED uses the same hydrological models as used by GS. DHED executes in a short-term time frame of up to 2-4 hours using a 5 minute time increment.

The DHED program solves the unit dispatch schedule which meets the following conditions:

- Minimises the deviations of reservoir storage levels from the target levels set by the HSC solution.
- Dispatches the committed units using piecewise linear unit input/output curves constructed for the real-time, telemetered, reservoir elevations so that these units operate at their theoretical maximum efficiency point wherever possible.
- Calculates the desired base points for the units under control and passes the obtained values to AGC for implementation of these control actions.
- Calculates unit MW schedules for the current time increment and future time increments within the study period.
- Calculates projected storage levels for each time increment.
- Refines the unit commitment schedule determined by the HSC function so that it may be used for the real-time schedule and dispatch of the units. Unit start-up and shut-down times are recomputed within a five minute resolution for those units scheduled for start-up or shutdown by HSC during the time horizon.
- Uses actual telemetered reservoir elevations to compute the maximum efficiency loading points of the units so that maximum utilisation of the available hydro energy is obtained.

- Unit loss penalty factors are incorporated by adjusting the effective unit efficiency curves according to the penalty factors supplied by the real-time Network Analysis software or from a fixed set.
- The reservoir target levels from the HSC study are incorporated as soft constraints so that if it is not possible to meet these constraints, the level restrictions will be relaxed by the minimum amount necessary to achieve required feasibility.
- DHED compares the output reservoir storage levels and unit generation levels with those from HSC and issue an alarm for any differences which exceed a threshold.

Input data for the DHED function includes the system load from AGC, forecast system load, forecast reservoir inflows, unit dispatch status from AGC, telemetered reservoir elevations and stored historical water flows for branches with transit times and desired storage levels from GS.

Output data from the DHED function includes unit start/stop times for the subset of units scheduled to start/stop within the DHED study horizon, unit MW targets for use by AGC for the current time increment and unit MW schedules for the subsequent time increments. DHED also provides branch flows, storage levels and spill flows throughout the hydrological model.

Chapter 5

Mathematical Model of the Large Scale Hydro System

5.1. Introduction

The most important part of optimal scheduling and dispatch is mathematical model used in the optimisation process. Appropriate models have been applied for a specific time horizon in the function. A nonlinear model is used for the rule based energy allocation simulation process to define an available amount of water. The generation scheduling part has been modelled with linear and integer variables. This is the most flexible model as the MILP represents the most difficult part to solve. Models in hydro dispatch are very similar to these used on generation scheduling with less flexibility as the hydro dispatch needs to satisfy the real-time system requirements. The theoretical model has been presented first and modifications and approximations have been presented later to insure a fast, reliable and practical algorithm. Those models are built from the same set of data. As the whole algorithm represents integrated approach for those functions, special attention has been made to ensure compatibilities in the parts of model which interact with other functions.

5.2. Energy allocation hydro simulator

The Hydro Simulator (HS) computes average flows, reservoir elevations, average energy generated for a given set of inflows to the run-of-river stations and releases from the medium storages. The Hydro Simulator uses a mathematical model of the hydro network to compute the flows and reservoir elevations for the inflows and scheduled releases. A time step of 24 hours is used in the simulation. Average power plant energies and flows are calculated for the 24 hour period.

Each node in the hydro model is assigned an order according to its relative position in the cascade so that the nodes are processed in an order so that all upstream flows are always known. The HS begins at the top of the cascade by releasing water from the head storage in the cascade storage for each time increment.

The Hydro Simulator solution continues by proceeding down the cascade, successively solving for the reservoir elevations and downstream flows using known flows in the upstream branches. The flows in the downstream branches are computed so that all upstream flows and natural inflows are used. Branch travel times may be included in the model for those delays which are greater than 12 hours. If the available generating units cannot absorb the net inflow, spill flow will be enabled to absorb the surplus flow. The energy generated is computed from the full non-linear input/output characteristics of the unit.

The solution of energy allocation presents input constraints for the generation scheduling part. An appropriate selection of variables which are used as constraints in the generation scheduling ensures that non-linear model in the

energy allocation is not causing and infeasibilities in mixed integer and linear model in the generation scheduling function.

5.3. Generation scheduling mathematical model

5.3.1. Introduction

The mathematical model used in the GS function incorporates the following components:

- Hydro system flow balance constraints. The hydro system is modelled as an interconnected system of reservoirs and flow paths. The net flow into each reservoir must equal the change in storage volume in the reservoir in each time increment.
- Reservoir level constraints. The reservoir water levels are constrained within upper and lower limits. For some reservoirs, target levels are applied as soft constraints according to the reservoir long-term draw down strategy. Constraints are also placed on reservoir draw down and fill between time increments.
- Flow limits. Limits are applied to flows and rate of change of flow on the water flow channels in the hydrological model.
- Spill constraints. If a reservoir elevation exceeds the spillway level, the spill flow is a non-linear function of the elevation above the spillway.

- **Generating unit constraints.** The generating units are modelled using a water to energy conversion function which incorporates the effect of head variation, penstock and tailrace losses. A special formulation is used to ensure that generating units operate at their theoretical maximum efficiency wherever possible. Restrictions on unit start-up behaviour are incorporated using minimum up and down times.
- **Flow Control Device Constraints.** The HSC function can schedule the status of pumps and valves. Constraints on the flows in these channels are imposed according to the on/off state of the pump/valve.
- **Tunnel/canal Constraints.** The flows in tunnels and canals are constrained according to a non-linear function of the upper and lower reservoir levels.
- **System load/reserve constraints.** Constraints are placed on the generating units so that the system load and reserve requirements are satisfied for each time increment.
- **Transmission flow constraints.** Constraints are placed on designated transmission flows.

5.3.2. Generator model

Because Mixed Integer Linear Programming is used to solve the Generation Scheduling problem, it is necessary to linearise the unit input/output curves so that linear constraints may be formulated for the power balance and reserve constraints.

The database contains the generator non-linear efficiency versus flow curves for multiple values of net head level. In addition, curves of tailrace level versus discharge and lower reservoir elevation and penstock loss curves are provided. Prior to commencing the GS study, linearised characteristics are constructed from these look-up tables around the operating point defined by the reservoir initial level and targeted Economic Operating Level (EOL).

Several different curve types are required to support the GS function:

- Maximum efficiency flow levels and corresponding net electrical power as a function of net head level. This characteristic is used to model the variation of efficiency with net head for units that can be committed/decommitted. These curves are augmented with additional terms which allow an operation away from the maximum efficiency when constraints are binding.
- On-line unit characteristics in which a two segment piecewise linear curve is utilised along with correction terms that allow for the effects of the head variation.

For each unit, a linear function of maximum efficiency flow versus head is formed as shown on Figure 5.1. The curve is constructed by linearising the maximum efficiency flow versus head characteristic around the operating net head level point. The linearisation is performed by selecting two net head data points either side of the reservoir operating head level. Then, the maximum efficiency flow and full gate flow are computed at these data points. The station efficiency is obtained from the efficiency look-up table for the flows and net head levels. The gross electrical power is calculated as $P_{\text{gross}} = 0.00981 q h_{\text{net}} \eta$ and the net electrical power by subtracting out the alternator losses.

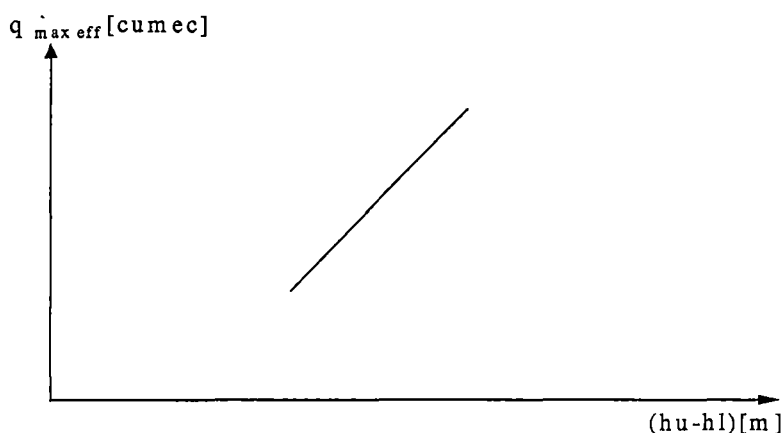

Figure 5.1: Maximum efficiency flow vs gross head

The net head values corresponding to the data points are then converted to gross head levels by adding in the penstock and tailrace losses corresponding to the flow levels at the two data points. These losses are computed from the look-up table data provided for the penstock and tailrace losses.

The linearisation is then performed by drawing a straight line between these two data points and extrapolating this line so that it encompasses the possible range of gross head for the study.

If the maximum efficiency flow q_{best} , is expressed as a linear function of gross head:

$$q_{best,i} = F + G (h_{u,i} - h_{l,i}) \quad (5.1)$$

where i present time interval.

Because we use reservoir volumes as state variables, the elevation/volume curves have to be linearised around the operating point defined by the initial reservoir levels $h_{u0,i}$ and $h_{l0,i}$ respectively.

$$h_{u,i} = h_{u0,i} + \frac{\partial h_{u,i}}{\partial s_{u,i}} \Delta s_{u,i} \quad (5.2)$$

$$h_{l,i} = h_{l0,i} + \frac{\partial h_{l,i}}{\partial s_{l,i}} \Delta s_{l,i} \quad (5.3)$$

The variables $\Delta s_{u,i}$ and $\Delta s_{l,i}$ are variations in volume from the initial levels.

$$q_{best,i} = F + G (h_{u0,i} - h_{l0,i}) + G \frac{\partial h_{u,i}}{\partial s_{u,i}} \Delta s_{u,i} - G \frac{\partial h_{l,i}}{\partial s_{l,i}} \Delta s_{l,i} \quad (5.4)$$

Then by assigning the following constants:

$$A = F + G (h_{u0,i} - h_{l0,i}) \quad (5.5)$$

$$B = G \frac{\partial h_{u,i}}{\partial s_{u,i}} \quad (5.6)$$

$$C = G \frac{\partial h_{l,i}}{\partial s_{l,i}} \quad (5.7)$$

The variation of $q_{best,i}$ can then be represented by the following relationship:

$$q_{best,i} = A + B\Delta s_{u,i} - C\Delta s_{l,i} \quad (5.8)$$

The generator net electrical power at maximum efficiency can then be represented by the curve shown in Figure 5.2.

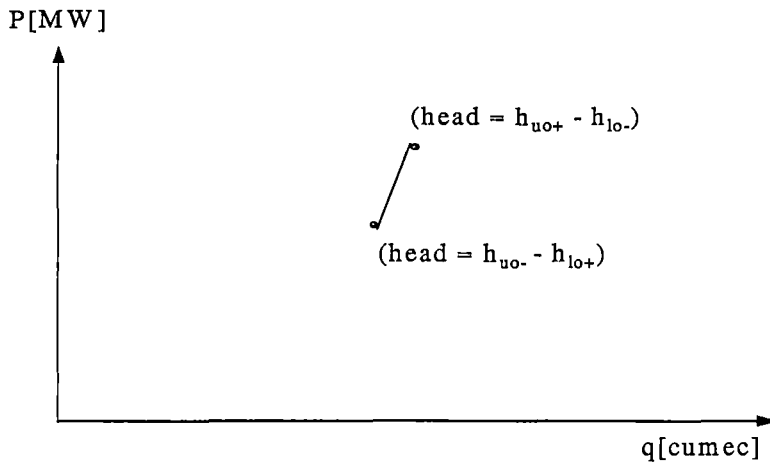

Figure 5.2: Unit input/output curve

This characteristic can be represented mathematically as a piecewise linear function using Separable Programming[26]:

$$P_{best,i} = \beta_1 P_1 + \beta_2 P_2 \quad (5.9)$$

$$q_{best,i} = \beta_1 q_1 + \beta_2 q_2 \quad (5.10)$$

where β_1 and β_2 present a coefficients of special-order-set variables[26].

It is also necessary to define two additional flow variables $q_{up,i}$ and $q_{dn,i}$ to be used when an operation away from the maximum efficiency is necessary to meet either a power balance or reservoir constraint.

$$P_{n,t} = P_{best,n,t} + A_{up,n} q_{up,n,t} - A_{dn,n,t} q_{dn,n,t} \quad (5.11)$$

$$q_{n,t} = q_{best,n,t} + q_{up,n,t} - q_{dn,n,t} \quad (5.12)$$

The constants $A_{up,n}$ and $A_{dn,n}$ are obtained from the generator non-linear input/output curve look-up tables. These factors are chosen so that they are equal to the incremental efficiency (MW/cumec) at the lowest head level.

$$A_{up,n} = (P_{fg,n} - P_{best,n}) / (q_{fg,n} - q_{best,n}) \quad (5.13)$$

$$A_{dn,n} = (P_{best,n} - P_{0.8,n}) / (q_{best,n} - q_{0.8,n}) \quad (5.14)$$

where

$P_{fg,n}$, $q_{fg,n}$ = Net electrical power, flow at full gate at head operating point;

$P_{best,n}$, $q_{best,n}$ = Net electrical power, flow at maximum efficiency at head operating point;

$P_{0.8,n}$, $Q_{0.8,n}$ = Net electrical power, flow at 80% of maximum efficiency level at head operating point;

The $q_{up,i}$ and $q_{dn,i}$ can be also used as piecewise linear function[25].

Additional models must also be developed for multiple unit stations. Because of the effects of penstock and tailrace losses, the efficiency drops as more units within a station are placed on-line. This effect can be modelled by considering each combination of units as a separate equivalent unit, only one of which can be on-line at the same time. Figure 5.3. illustrates the flow characteristics of a multiple unit power station.

The flow characteristics implicitly incorporate the effects of penstock and tailrace losses. The linearised characteristics are constructed from the non-linear look-up tables which include the effects of these losses on the net head level.

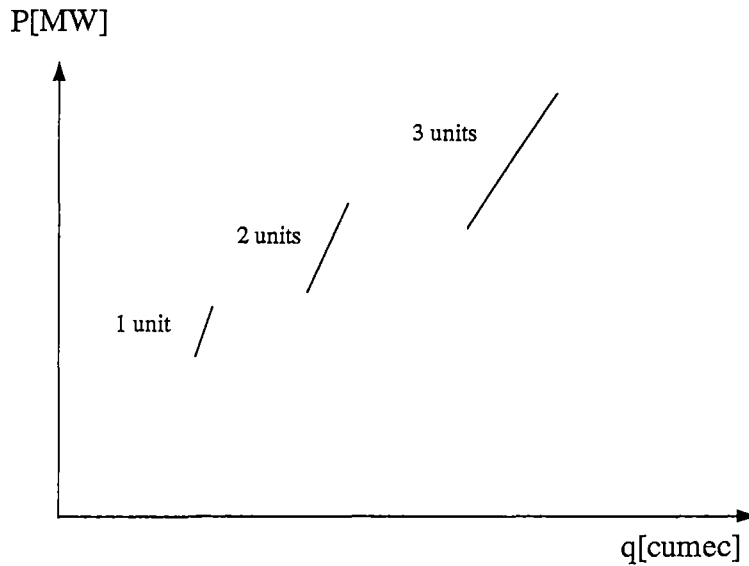

Figure 5.3: Multimachine input/output curve

The manner in which physical units within a station are mapped to logical units for solution is controlled by user-specified priorities for units within the station. These priorities ensure that the combinations of units are dispatched in this priority order. The model builder selects the physical unit with the highest priority to be loaded first in the station model.

Another model type is used for on-line stations, these that are on-line for the whole study period. This model is required to compute the flow as the head level varies during the study.

This two segment piecewise linear characteristic is represented using the following equation:

$$P_i = \beta_1 P_1 + \beta_2 P_2 + K_u \Delta s_{u,i} - K_l \Delta s_{l,i} \quad (5.15)$$

$$q_i = \beta_1 q_1 + \beta_2 q_2 \quad (5.16)$$

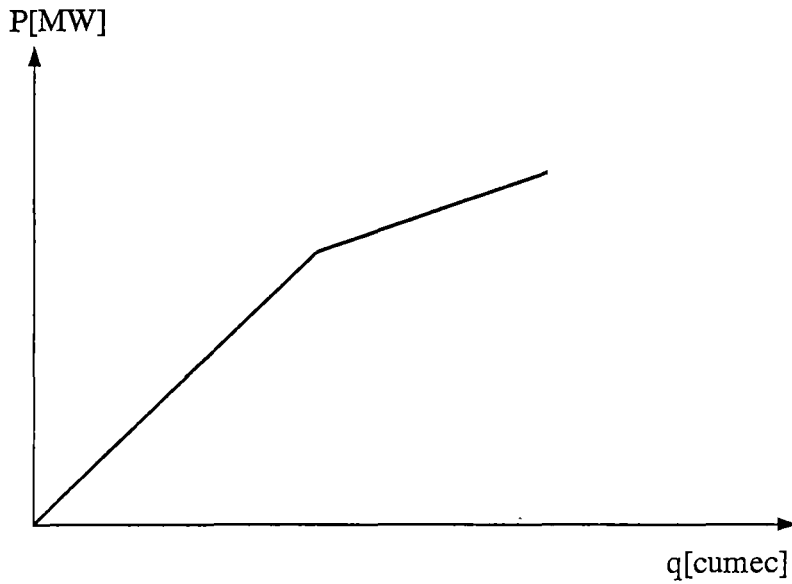

Figure 5.4: Fixed run unit Input/Output curve

The head variation constants K_U and K_I are computed from:

$$K_U = 0.00981 q_{best} \eta_{best} \frac{\partial h_U}{\partial s_U} \quad (5.17)$$

$$K_I = 0.00981 q_{best} \eta_{best} \frac{\partial h_I}{\partial s_I} \quad (5.18)$$

5.3.3. Constraints model

The following constraints are used in the model:

Node Equality Constraint. A water balance equality constraint is applied to each node to ensure that the change in volume of the reservoir is equal to the net flow from upstream reservoirs and inflows less the flow to downstream reservoirs. Travel times between nodes are incorporated by using the flow in the incoming branch from the previous time increment which corresponds to the current time increment less the number of time increments corresponding to the branch travel

time. For those branches with travel times, it is also necessary to specify flows in branches prior to the start of the study.

For node i the following constraint applies for each time increment:

$$\begin{aligned}
 & - \sum_{ij} Q_{ji,t-\tau_{ij}} + \sum_{ij} Q_{ij,t} + (s_{k,t} - s_{k,t-1}) K_R = \\
 & = b_{i,t} + \sum_{ji} Q_{hist,ji,t-\tau_{ji}} \qquad (5.19)
 \end{aligned}$$

where

i = current node;

j = node connected with i node;

t = current time increment;

τ_{ij} = water travel time between i and j;

K_R = conversion constant $(10^6/3600)/(\text{Time Increment})$;

$Q_{hist,ji,t-\tau_{ji}}$ = branch flow prior to commencement of study.

Node equality constraints do not have to be applied to catchment discharge nodes.

Reservoir Level Constraints. Upper and lower limits are placed on the reservoir volumes at each time increment. The default limits are the reservoir normal minimum operating level and the maximum flood level, but limits may be specified on an individual time increment basis if desired. These reservoir level constraints may be entered by the user on a global and individual time step basis.

$$s_{min,k,t} \leq s_{k,t} \leq s_{max,k,t} \qquad (5.20)$$

where

$s_{\min,k,t}$ = minimum volume for storage k at increment t;

$s_{\max,k,t}$ = maximum volume for storage k at increment t.

Branch Flow Constraints. Individual limits may be placed on the flows on each branch for each time increment.

$$Q_{\min,ij,t} \leq Q_{ij,t} \leq Q_{\max,ij,t} \quad (5.21)$$

where

$Q_{\min,ij,t}$ = minimum flow between branches i and j at time increment t;

$Q_{\max,ij,t}$ = maximum flow between branches i and j at time increment t.

These limits may be used to enforce minimum required generating unit discharge constraints and minimum downstream release constraints.

Generating Unit Constraints. The linearised model described in Section 5.3.2. {5.15.,5.16.} are supplemented with other constraints to support the generator model:

$$q_{n,t} - u_{n,t} q_{\min,n} \geq 0 \quad (5.22)$$

$$q_{n,t} - u_{n,t} q_{\max,n} \leq 0 \quad (5.23)$$

$$P_{n,t} - u_{n,t} P_{\min,n} \geq 0 \quad (5.24)$$

$$P_{n,t} - u_{n,t} P_{\max,n} \leq 0 \quad (5.25)$$

$$u_{n,t} + \beta_{0,n,t} = 1 \quad (5.26)$$

where

$u_{n,t}$ = integer variable for unit status(on/off).

If the unit is on-line, the maximum efficiency flow q_{best} as a function of upper and lower reservoir volumes is given by:

$$q_{best} = A + B\Delta s_{u,t} - C\Delta s_{l,t}, \quad (5.27)$$

while if the unit is off-line q_{best} is not constrained.

This coupling of q_{best} to the reservoir volume and the unit status can be represented by the following pair of constraints:

$$(1 - u_{n,t}) q_{max,n} + (\beta_{1,n,t} q_{1,n} + \beta_{2,n,t} q_{2,n}) - (A_n + B_n\Delta s_{u,t} - C_n\Delta s_{l,t}) \geq 0 \quad (5.28)$$

$$(1 - u_{n,t}) q_{max,n} - (\beta_{1,n,t} q_{1,n} + \beta_{2,n,t} q_{2,n}) + (A_n + B_n\Delta s_{u,t} - C_n\Delta s_{l,t}) \geq 0 \quad (5.29)$$

These two constraints force q_{best} to be equal to $(A + B\Delta s_u - C\Delta s_l)$ if the unit is on line and allow it to be any value if the unit is off-line. The other constraints will force the total flow to zero if the unit is off-line.

Minimum up and down times may also be applied to the units using the following constraints:

$$u_{n,t} - u_{n,t-1} = Y_{n,t} - Z_{n,t} \quad (5.30)$$

Minimum up time:

$$y_{n,t} + z_{n,t+1} + z_{n,t+2} + z_{n,t+3} + \dots + z_{n,t+NUP} \leq 1 \quad (5.31)$$

Minimum down time:

$$z_{n,t} + y_{n,t+1} + y_{n,t+2} + y_{n,t+3} + \dots + y_{n,t+NDN} \leq 1 \quad (5.32)$$

The number of start-ups in a given period may also be controlled using an additional constraint:

$$\sum_t y_{n,t} \leq NS_{\max} \quad (5.33)$$

where NS_{\max} is the maximum number of unit start-ups allowed in the study period for unit n .

These constraints may be applied to individual 24 hour periods and for the entire study period for multiple day studies.

Alternatively, the unit start-ups may be controlled using a start-up cost as a penalty in the objective function to discourage unit start-ups. the following additional term is added to the objective function:

$$- \sum_t \sum_n y_{n,t} C_{\text{start},n} \quad (5.34)$$

The Energy Allocation solution may be translated into a number of hours on-line at maximum efficiency. This number of hours on-line may then be constrained as follows:

$$NUP_{\min} \leq \sum_t u_{n,t} \leq NUP_{\max} \quad (5.35)$$

where

NUP_{\min} = minimum up time for unit n during study period;

NUP_{\max} = maximum up time for unit n during study period.

In multiple unit power stations, a separate equivalent unit is modelled for each combination of units on-line.

An on/off variable is supplied for each equivalent unit corresponding to the different combinations of units on-line.

$$u_{1,n,t} + u_{12,n,t} + u_{123,n,t} \leq 1 \quad (5.36)$$

where

$u_{1,n,t}$ = 1 unit on-line;

$u_{12,n,t}$ = 2 units on line;

$u_{123,n,t}$ = 3 units on-line.

The individual unit behaviour may be controlled by including start/stop variables for each unit so that:

$$y_{n,1,t} - z_{n,1,t} = (u_{n,1,t} + u_{n,12,t} + u_{n,123,t}) - (u_{n,1,t-1} + u_{n,12,t-1} + u_{n,123,t-1}) \quad (5.37)$$

$$y_{n,2,t} - z_{n,2,t} = (u_{n,12,t} + u_{n,123,t}) - (u_{n,12,t-1} + u_{n,123,t-1}) \quad (5.38)$$

$$y_{n,3,t} - z_{n,3,t} = (u_{n,123,t}) - (u_{n,123,t-1}) \quad (5.39)$$

In solution, logical units in a station will be represented. These logical units will be mapped to physical units using a user-entered priority order. This priority order will also be used to determine which unit individual restrictions will be applied to.

The other constraints described earlier for the number of start-ups and the number of hours on-line may also be applied to these variables in a corresponding manner.

For the head storage in the cascade, an additional constraint is added to constrain the total release down the cascade to that scheduled by the storage policy.

$$q_{\text{release},n} - q_{\text{tol}} \leq \sum_t q_{n,t} \leq q_{\text{release},n} + q_{\text{tol}} \quad (5.40)$$

where $q_{\text{release},n}$ is the scheduled release from the Energy Allocation and q_{tol} is a user specified tolerance.

Available unit operating modes for each unit for each time increment include:

- Unavailable. In this mode the unit is off-line. The branch flow corresponding to this unit is given maximum and minimum limits of zero.
- Must Run. In this mode the unit must be on-line in this time increment. The unit status variable $u_{n,t}$ is given maximum and minimum limits of one.
- Fixed Run. The unit must operated at a fixed MW for this time increment. The equivalent branch flow is calculated from the unit efficiency curve for

the given head level and the maximum and minimum flow limits for this flow branch are set to this fixed value.

- Best Run The unit is to be on-line at its maximum efficiency for the initial head level for this time increment. The maximum efficiency flow is calculated for the head level at this time increment and the unit maximum and minimum flow limits are set to this value.
- Cycling Units in this mode may be started, shutdown and loaded as required for the optimal hydro schedule.

Some additional constraints are added for fixed run units so that their output level is maintained as the head varies:

$$P_{\text{FIXED}} - (\beta_1 P_1 + \beta_2 P_2 + K_u \Delta s_u - K_l \Delta s_l) = 0 \quad (5.41)$$

$$q_{n,t} - \beta_1 P_1 + \beta_2 P_2 = 0 \quad (5.42)$$

$$\beta_0 + \beta_1 + \beta_2 = 0 \quad (5.43)$$

where P_{FIXED} = predefine fixed unit generation.

Because these units are scheduled to be on-line at a fixed output level, integer on/off variables are not required for the fixed run units.

Spill Constraints. The flow in the spill branch is a non-linear function of the reservoir elevation over the spillway. A piecewise linear approximation of this relationship is used to model the spill flow behaviour. This spill characteristic is

illustrated in Figure 5.5. This spill characteristic applies to open/ungated spillways. There may be more than one spillway per reservoir.

Gated spillways may also be modelled. In the case of gated spillways, the user must specify the gate setting for the study. A separate elevation/flow characteristic will be stored for each gate setting.

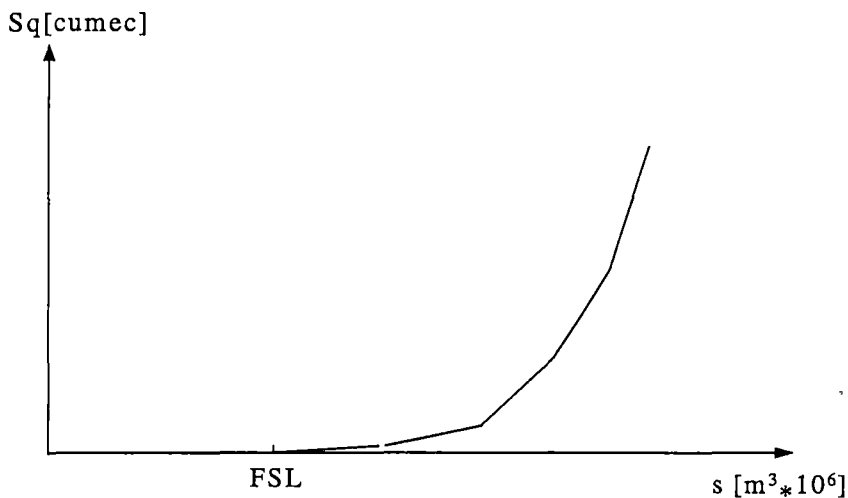

Figure 5.5: Reservoir spill flow vs volume

Separable Programming is also used to model the piecewise linear behaviour of spill with reservoir elevation. Up to ten data points may be stored for the spill characteristic.

Two additional constraints are added at each time increment to represent the spill behaviour. Up to ten solution variables ζ are used to model the piecewise linear characteristic (in the example here only four variables are shown for clarity):

$$\begin{aligned}
 Sq_{ij,t} = & \zeta_{1,m,t} Q_{1,m} + \zeta_{2,m,t} Q_{2,m} + \zeta_{3,m,t} Q_{3,m} + \\
 & + \zeta_{4,m,t} Q_{4,m}
 \end{aligned} \tag{5.44}$$

$$s_{k,t} = \zeta_{1,m,t} S_{1,m} + \zeta_{2,m,t} S_{2,m} + \zeta_{3,m,t} S_{3,m} + \zeta_{4,m,t} S_{4,m} \quad (5.45)$$

$$\zeta_{1,m,t} + \zeta_{2,m,t} + \zeta_{3,m,t} + \zeta_{4,m,t} = 1 \quad (5.46)$$

where

$Q_{i,m}$ = spill curve piecewise linear break points;

$S_{i,m}$ = volume curve piecewise linear break points;

$\zeta_{i,m,t}$ = special-order-set coefficients [26].

Reservoir Target Level Constraints. For each reservoir, a target level range may be specified for any time increment. These target levels may be applied as a hard constraint in which case a simple upper and lower limit is imposed on the reservoir volume for that time increment. In some cases, it can be difficult to obtain a solution using the target levels as hard constraints due to infeasibility. This potential infeasibility may be prevented by using piecewise linear penalty functions to enforce the reservoir target level constraints. If the level cannot be reached by scheduling the generating plants, the optimisation solution will try to set the reservoir level as close as possible to the target level.

Separable Programming is used to model the piecewise linear penalty functions.

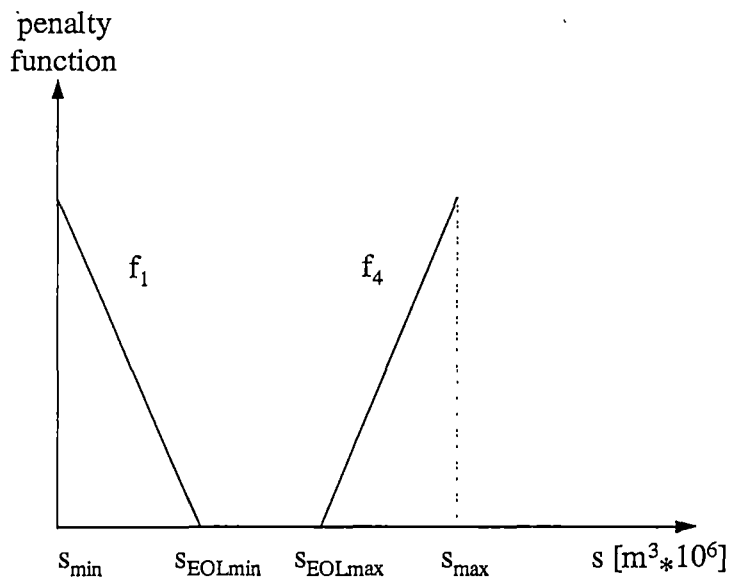

Figure 5.6 : Reservoir target levels penalty function

Variables ψ are used as the weighting variables for the penalty function:

$$s_{k,t} = \psi_{1,k,t} s_{\min,k} + \psi_{2,k,t} s_{EOL\min,k} + \psi_{3,k,t} s_{EOL\max,k} + \psi_{4,k,t} s_{\max,k} \quad (5.47)$$

$$\psi_{1,k,t} + \psi_{2,k,t} + \psi_{3,k,t} + \psi_{4,k,t} = 1 \quad (5.48)$$

The penalty function (Figure 5.6) for the reservoir levels is:

$$F(\psi) = f_1 \psi_{1,k,t} + f_4 \psi_{4,k,t} \quad (5.49)$$

where

$$f_1 = K_{\text{targ},k} (s_{EOL\min,k} - s_{\min,k}) \quad (5.50)$$

$$f_4 = K_{\text{targ},k} (s_{\max,k} - s_{EOL\max,k}) \quad (5.51)$$

$K_{\text{targ},k}$ = penalty function weighting factor

$s^{\text{EOLMIN},k}$, $s_{\text{EOLMIN},k}$ = target levels for storage k.

Tunnel/Canal Constraints. Tunnel and canal flows are a non-linear function of the upper and lower reservoir elevations of the connected reservoirs. Flow may be bi-directional in the tunnels and canals. These functions can be linearised so that the flow in the tunnel or canal can be represented as a linear function of the upper and lower reservoir volumes.

$$Q_{ij,t} = \alpha_i s_{i,t} + \alpha_j s_{j,t} + q_{0,ij} \quad (5.52)$$

where:

α_i = upper reservoir tunnel/canal flow linearisation constant;

α_j = lower reservoir tunnel/canal flow linearisation constant;

$q_{0,ij}$ = flow linearisation constant.

Power Balance Constraint. The sum of the generating unit outputs must equal the adjusted system demand at each time increment.

$$\sum_n (1/PF_{n,t}) P_{n,t} = D_{\text{adj},t} - P_{\text{DC},t} - P_{\text{therm},t} \quad (5.53)$$

$$D_{\text{adj},t} = \sum_n (1/PF_{n,t}) P_{n0,t} (D_t / D_{0,t}) \quad (5.54)$$

where

$D_{\text{adj},t}$ = adjusted system demand at time increment t

$PF_{n,t}$ = Unit n penalty factor from Network Analysis for time step t

$P_{n0,t}$ = Unit n generation level at which penalty factors were calculated
by the Real-time or Study Penalty functions

$P_{DC,t}$ = HVDC link scheduled import flow for time increment t.

$P_{therm,t}$ = Thermal generation scheduled for time increment t

D_t = System load from load forecast for time step t

$D_{0,t}$ = System load at which penalty factors were calculated

Reserve Constraint. For each time increment the reserve requirement constraint is included:

$$\sum_n (u_{n,t} P_{max,n,t} - P_{n,t}) \geq R_t \quad (5.55)$$

where R_t = reserve requirement at time increment t

Transmission Constraints. The extended electrical constraint enforcement feature will be implemented using sensitivity information from the Network Analysis subsystem that provides transmission line MW flows as a function of unit generation.

$$P_{ij,t} = \sum \alpha_{ij,n,t} P_{n,t} + \alpha_{ij,0,t} \quad (5.56)$$

where

$\alpha_{ij,n,t}$ = the sensitivity of line flow (between nodes i and j) to the output of generator n

$\alpha_{ij,0,t}$ is a linearisation constant.

The $\alpha_{ij,n,t}$ are obtained from the factorised transposed power flow Jacobian matrix in the same manner as penalty factors are obtained.

The following equation is used for each transmission line constraint for each time increment:

$$\sum \alpha_{ij,n,t} P_{n,t} + \alpha_{ij,0,t} \leq P_{ij,max} \quad (5.57)$$

Maximum Reservoir Drawdown and Fill Constraints. For each reservoir, a limit is applied to the change in storage between time increments:

$$- \Delta s_{max,k} \leq s_{k,t} - s_{k,t-1} \leq \Delta s_{max,k} \quad (5.58)$$

where $\Delta s_{max,k} \leq$ maximum allowed drawdown of reservoir k between two time increments

Maximum Rate of Change of Generating Unit Discharges. For each power plant, a maximum rate of change of discharge constraint is applied:

$$- \Delta q_{max,n} \leq q_{n,t} - q_{n,t-1} \leq \Delta q_{max,n} \quad (5.59)$$

where $\Delta q_{max,n}$ is the maximum change in flow permitted within one time increment.

Maximum Rate of Change of Downstream Releases. For each power plant discharge, a maximum rate of change of discharge constraint may be applied:

$$- \Delta Q_{max,ij} \leq Q_{ij,t} - Q_{ij,t-1} \leq \Delta Q_{max,ij} \quad (5.60)$$

where $\Delta Q_{max,ij}$ = maximum allowed downstream release.

Unit Capacity Limitations at Start-up. Some units have a limitation that they must be on-line at minimum load for several hours before they can generate above this load level. This constraint can be implemented making use of the start-up variable $y_{n,t}$:

$$\begin{aligned}
 q_{\min,n} (y_{n,t} + y_{n,t-1} + y_{n,t-2} + \dots + y_{n,t-N}) &\leq q_{n,t} \leq \\
 q_{\min,n} (y_{n,t} + y_{n,t-1} + y_{n,t-2} + \dots + y_{n,t-N}) + \\
 + q_{\max,n} (1 - y_{n,t} - y_{n,t-1} - y_{n,t-2} - \dots - y_{n,t-N}) &\quad (5.61)
 \end{aligned}$$

Where N is the number of time increments which the unit must remain at minimum load after start-up.

Unit Electrical Power Ramp Limits. Constraints are also included to limit the rate of change of unit net electrical power between time steps:

$$- RR_{\max,n} * T * 60 \leq P_{n,t} - P_{n,t-1} \leq RR_{\max,n} * T * 60 \quad (5.62)$$

where $RR_{\max,n}$ is the unit maximum ramp rate in MW/min.

Flow Control Devices. The following flow control devices may be modelled:

1. On/off valves or pumps with fixed flow. An integer on/off variable will be added to the formulation so that HSC may schedule the status of the flow control devices. The following constraint equation will be used:

$$Q_{ij,t} - u_{\text{valve},t} Q_{\text{valve}} = 0 \quad (5.63)$$

2. On/off valves or pumps with variable flow. These will be similar to the above except that the flow may vary between upper and lower limits.

$$Q_{ij,t} - u_{\text{valve},t} Q_{\min} \geq 0 \quad (5.64)$$

$$Q_{ij,t} - u_{\text{valve},t} Q_{\max} \leq 0 \quad (5.65)$$

3. On/off valves or pumps with variable flow where the upper flow limit is determined by the reservoir level. This type will be modelled using the above constraints except Q_{\max} will be set to a nominal value and the following constraint will be added:

$$Q_{ij,t} - Q_{\max}(s_{k,t}) \leq 0 \quad (5.66)$$

where $Q_{\max}(s_{k,t})$ is a linear function of the reservoir elevation.

4. Bypass valves may also be modelled by including a flow branch which has a user-enterable penalty applied to it so that it will only allow flow when it is required to maintain feasibility.

5.3.4. Objective function

The objective of the optimisation is to maximise the electrical energy produced by the released water. This objective function can be implemented by defining an additional variable in each time increment which represents the additional power generated by the system as a result of taking advantage of the additional energy produced by the head variation. A piecewise linear objective function of the following form is used:

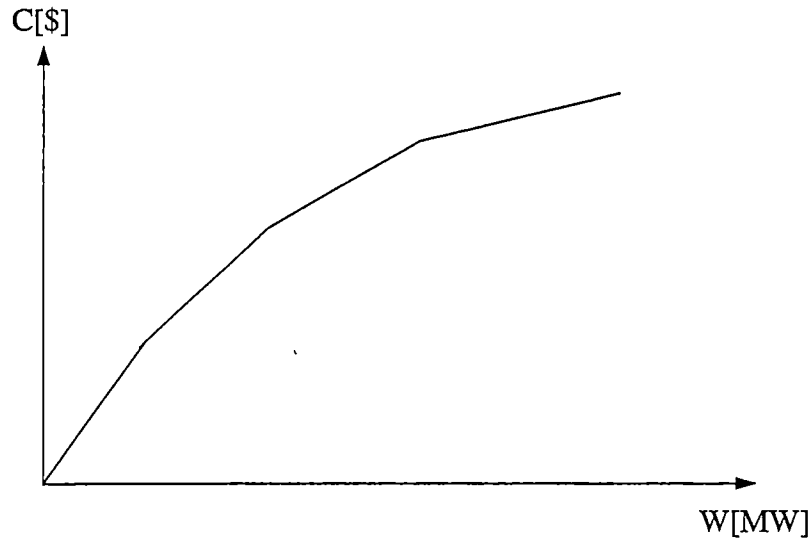

Figure 5.7 : Cost function

An additional state variable W is used to represent the additional power generated by the run-of-river generators. The system load requirement is modified by a small amount W_{FIX} so that the power balance constraint becomes:

$$\sum_n P_{n,t} - W_t = D_t - W_{FIX} \quad (5.67)$$

A set of Special Ordered Set variables are defined to represent the W_{up} variables and the cost characteristic:

$$W_t = \omega_{1,t} W_1 + \omega_{2,t} W_2 + \omega_{3,t} W_3 + \omega_{4,t} W_4 \quad (5.68)$$

$$C_{w,t} = \omega_{1,t} C_1 + \omega_{2,t} C_2 + \omega_{3,t} C_3 + \omega_{4,t} C_4 \quad (5.69)$$

where $\omega_{i,t}$ = special-order set coefficients[26].

This composite objective function results in the maximisation of the additional generation obtained from taking advantage of the head variation while minimising the deviation from maximum efficiency and minimising spill and the deviation from reservoir level targets.

The objective function used in the Generation Allocation sub-problem then becomes:

$$\begin{aligned} \text{Maximise } \sum_t & (\sum_i \omega_{i,t} C_i - K_{up} q_{up,n,t} + K_{dn} q_{dn,n,t} - K_{targ} \sum_k \\ & (f_1 \psi_{1,k,t} + f_4 \psi_{4,k,t})) \\ & - K_{spill} \sum_{s(ij)} Q_{s(ij),t} - \sum_n y_{n,t} C_{start,n} \end{aligned} \quad (5.70)$$

where

t = time increment;

k = storage;

s(ij) = spillbranch between node i and j;

n = generator.

The piecewise linear cost function ensures that the additional generation obtained from the head variation is evenly distributed over the time increments.

5.4. Dynamic hydro economic dispatch mathematical model

5.4.1. Introduction

Dynamic dispatch presents a real-time economic adjustment for the scheduling. In this case, the dispatch executes for the study period and compares results with the scheduling results. Because of the close relation between generation scheduling and dynamic economic dispatch, models are also very similar. In this section only differences between the models are discussed. Dispatch also has a close loop control connection with automatic generation control and a more precise model is necessary.

5.4.1. Generator model

Because Mixed Integer Linear Programming is used to solve the Hydro Economic Dispatch problem, it is necessary to linearise the unit input/output curves so that linear constraints may be formulated for the power balance constraint.

The DHED function uses a similar model for the hydro system as is used by the Hydro Scheduling and Commitment function. A multi-segment piecewise-linear input/output curve of up to eight segments is constructed for each time increment from the look-up tables. The initial telemetered head level is used for the curves for the initial time increment and levels obtained by interpolation between this level and the target levels at the end of the DHED study period are used for the subsequent time steps.

These curves are constructed on a station basis for a combination of units on-line. It is assumed that all on-line units within a station will be equally loaded.

This characteristic is constructed from the look-up tables as follows:

1. Find the gross head level corresponding to the telemetered upper and lower reservoir levels for the linearisation.
2. Set the upper and lower flow limits as full gate flow and minimum generation level for the number of units on-line. Divide this flow range into eight increments.

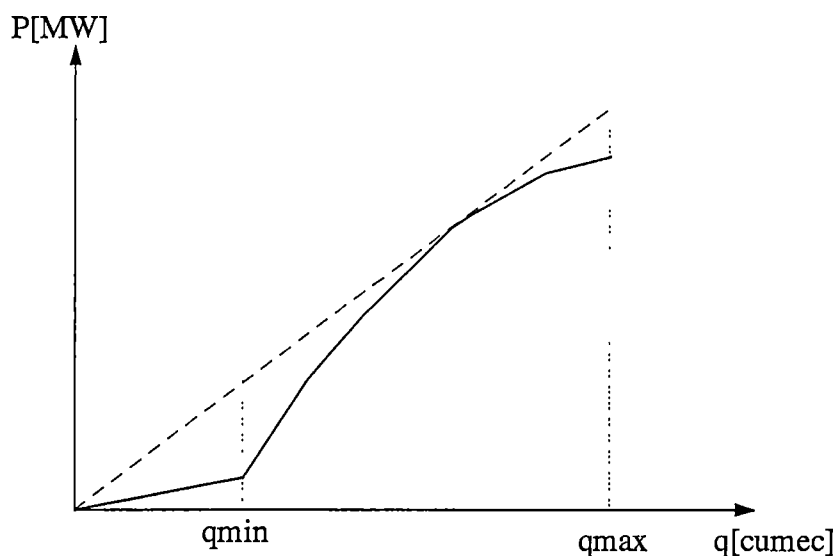

Figure 5.8: Station input/output curve

3. For each flow increment, compute the net head by subtracting the penstock and tailrace losses and then look up the turbine efficiencies.

4. For each flow increment, compute the gross electrical power at maximum efficiency and full gate from $P = 0.00981 Q H_{net} \eta$. Convert to net electrical power by subtracting out the alternator losses.

5.4.2. Constraints model

Power Balance Constraint. The sum of the generating unit outputs must equal the adjusted system demand at each time increment.

$$\sum_n (1/PF_{n,t}) P_{n,t} = D_{adj,t} - P_{DC,t} - P_{therm,t} \tag{5.71}$$

$$D_{adj,t} = \sum_n (1/PF_{n,t}) P_{n0,t} (D_t / D_{0,t}) \tag{5.72}$$

where

$D_{adj,t}$ = adjusted system demand at time increment t

$PF_{n,t}$ = Unit n penalty factor from Network Analysis for time step t

$P_{n0,t}$ = Unit n generation level at which penalty factors were calculated
by the Real-time or Study Penalty functions

$P_{DC,t}$ = HVDC link scheduled import flow for time increment t.

$P_{therm,t}$ = Thermal generation scheduled for time increment t

D_t = System load from load forecast for time step t

$D_{0,t}$ = System load at which penalty factors were calculated

Transmission Constraints. The extended electrical constraint enforcement feature will be implemented using sensitivity information from the Network Analysis subsystem that provides transmission line MW flows as a function of unit generation.

$$P_{ij,t} = \sum \alpha_{ij,n,t} P_{n,t} + \alpha_{ij,0,t} \quad (5.73)$$

where

$\alpha_{ij,n,t}$ = the sensitivity of line flow (between nodes i and j) to the output of generator n

$\alpha_{ij,0,t}$ is a linearisation constant.

The $\alpha_{ij,n,t}$ are obtained from the factorised transposed power flow Jacobian matrix in the same manner as penalty factors are obtained.

The following equation is used for each transmission line constraint for each time increment:

$$\sum \alpha_{ij,n,t} P_{n,t} + \alpha_{ij,0,t} \leq P_{ij,max} \quad (5.74)$$

5.4.4. Objective function

The objective of the DHED solution is to minimise the deviations of the reservoir levels from their target values provided by the HSC function, minimise energy loss through spill and .

$$\begin{aligned} & \text{Minimise } \sum_t (K_{targ} \sum_k (f_1 \psi_{1,k,t} + f_4 \psi_{4,k,t})) + \sum_n (EFACT_n q_{n,t}) \\ & - K_{spill} \sum_{q(ij)} Q_{ij,t} \end{aligned} \quad (5.75)$$

where

t = time increment;

k = storage;

$s(ij)$ = spillbranch between node i and j ;

n = generator.

The $EFACT_n$ are calculated as follows:

$$EFACT_n = EFACTA_n * EFACTO_n$$

$$EFACTA_n = (1 + \varepsilon_n) * (\Delta P / \Delta Q)_{\eta_{\max 1, \text{ref}}} / (\Delta P / \Delta Q)_{\eta_{\max 1, n}}$$

where

ε_n = a small number derived from a user defined priority list so that units are dispatched in the order defined in the list;

$(\Delta P / \Delta Q)_{\eta_{\max 1, \text{ref}}}$ = unit input/output characteristic slope at maximum efficiency for the reference unit which is normally the first in the priority list;

$(\Delta P / \Delta Q)_{\eta_{\max 1, n}}$ = unit n input/output characteristic slope at maximum efficiency;

$EFACTO_n$ = user defined weighting factor to allow manual adjustment of the unit dispatch priorities with default value of one.

Chapter 6

Case Studies: Hydro Electric Power System of Tasmania

6.1. Introduction

In this chapter results of an application of the algorithm are discussed based on the operation of the Hydro Electric Commission's power system in Tasmania. Actual results are derived from the Commission's Energy Management System - hydro applications software- where the presented algorithm was implemented in a Landis & Gyr Energy Management System software.

Tasmania is an island state of Australia with a hydro plant generation installed capacity of 2350MW and sufficient standby thermal installed capacity of 240MW to cover extreme drought periods. The hydro system consists of 40 interconnected storage reservoirs within six catchment areas. There are different sizes of storages with accumulations of few years, few months, few days and some accumulations only few hours. There are 26 hydro power plants with a total of 54 units. They are different constructions and include Pelton, Francis and Kaplan turbines. The system base load is around 800MW, peak load around 1300MW and average system daily load around 1000MW.

6.2. Example of real system schedule

A real system schedule is chosen as an example to discuss an implementation of the algorithm. A dry period schedule is used, because a larger number of units need to be committed and decommitted and water usage is spread across a large number of stations. This presents a more complex schedule as the number of possible scheduling options significantly increases.

Today, the method of scheduling is a manual heuristic approach, with operator interactive involvement. One station is assigned as the 'frequency station' and that station power output is the difference between system load and sum of generation of the other stations, which are planned for maximum efficiency operation. In an interactive, iterative procedure operators fit energy blocks (based on maximum efficiency operation and one start of the machine) under the load curve. It is important that all blocks must fit under the curve and the remainder is covered by the 'frequency station'. There are three major concerns about this algorithm. The 'frequency station' operates inefficiently. The head optimisation is not taken into account, because of the required time to produce the schedule. And any changes in inflow or load forecast during real-time operation are handled in an ad hoc, rather than on the optimal manner, because of a lack of time to reproduce a new schedule.

The new algorithm has incorporated many of the advantages of the previous algorithm, but it also solves the problems which occur due to manual scheduling. The solutions of these two schedules are not the same, as the new algorithm incorporate new features like power balance constraint relaxation and head optimisation.

The following example presents a typical schedule. Figure 6.1 shows the forecasted demand curve (area) and planned generation (bars) based on the new algorithm schedule.

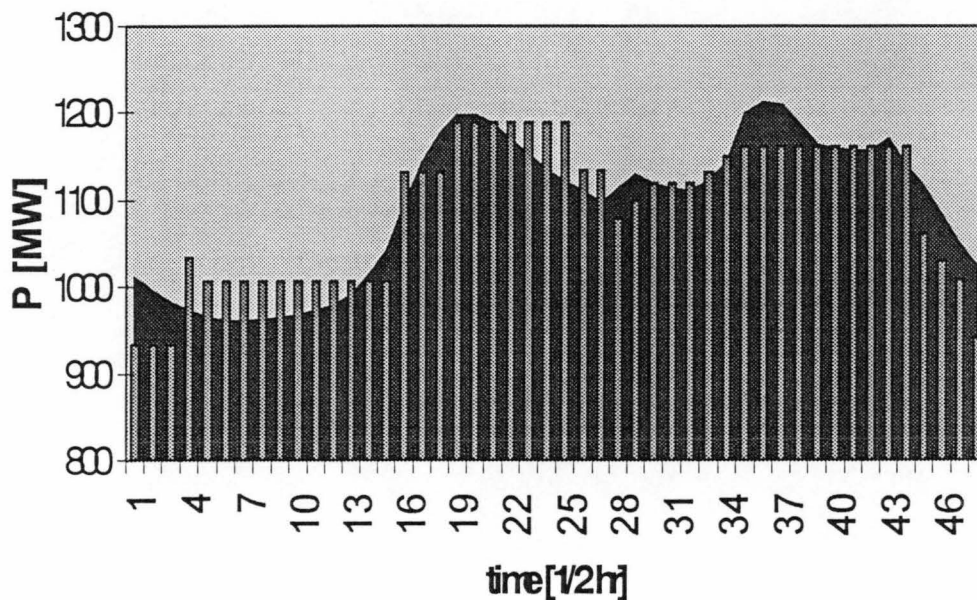

Figure 6.1. Demand/generation curve

In the schedule, all hydro power stations operate on maximum efficiency only. In the existing schedule, generation matches the load. All units except the 'frequency station' operate with the same block energy in both schedules. Figure 6.2 presents the 'frequency station' operation under the current schedule (area) and under the new algorithm schedule (bars). In this case the 'frequency station' is used to ensure that generation will match the load in the manual schedule. From this figure it can be seen that in the manual schedule, on the top of inefficient operation of the station because of operation away from maximum efficiency, it is also difficult to make decisions for commitment/decommitment of this unit.

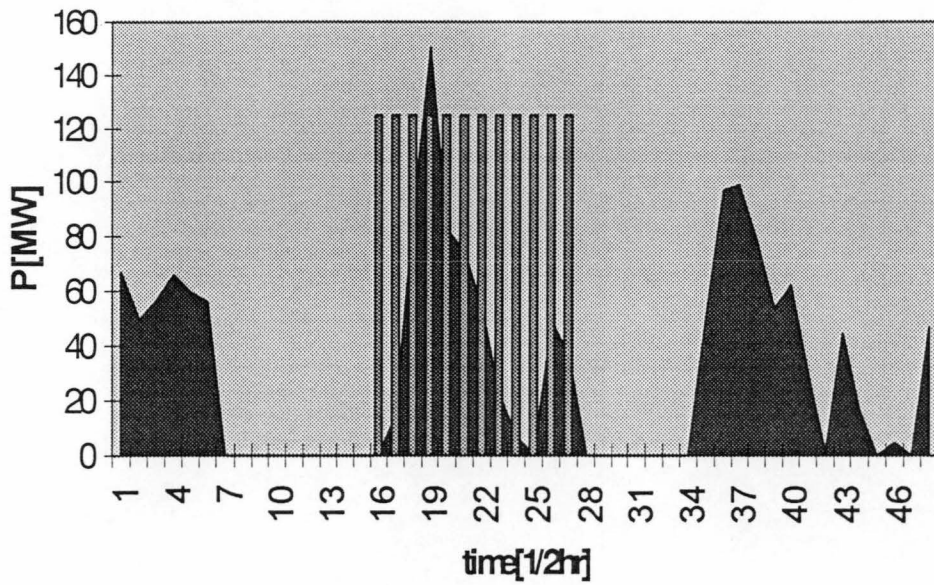

Figure 6.2. 'Frequency station' generation (Gordon)

The question of matching load and generation in real-time arise by implementing new algorithm.

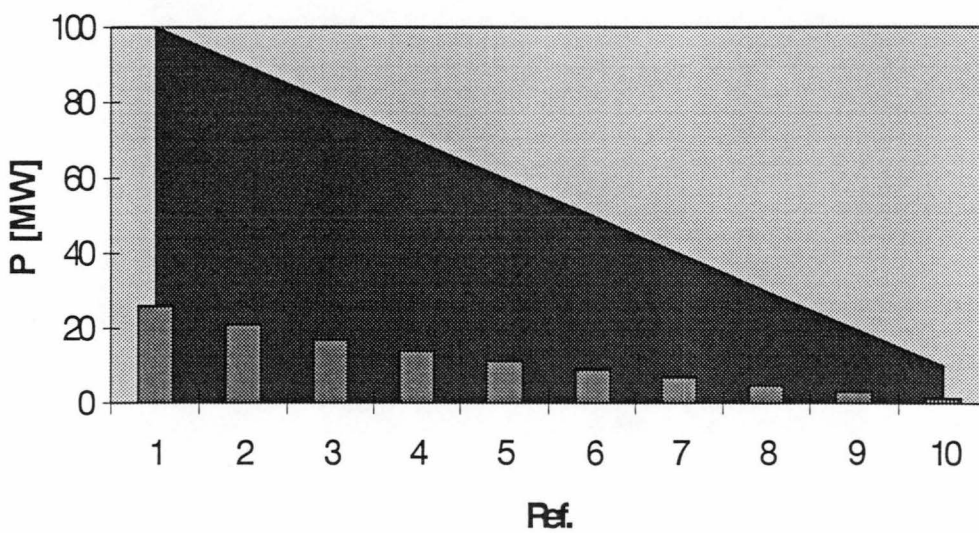

Figure 6.3. Savings based on maximum efficiency deviation operation

The problem is overcome by minimising the difference between generation and load during scheduling and by spreading the offset on as many units as available during real-time operation. Figure 6.3 shows possible savings (bars) by using number of stations to accommodate this offset (area) caused by relaxation of power balance constraint (as in figure 6.1). The algorithm allows these differences to be adjusted by a number of units in real time - HED operation. It can be seen that savings can be up to 25MW (2.5%) for the period between 22-16 time increments on Figure 6.2. But average daily savings are estimated up to 1%. In Figure 6.4. the initial HSC plan for part of the day is presented.

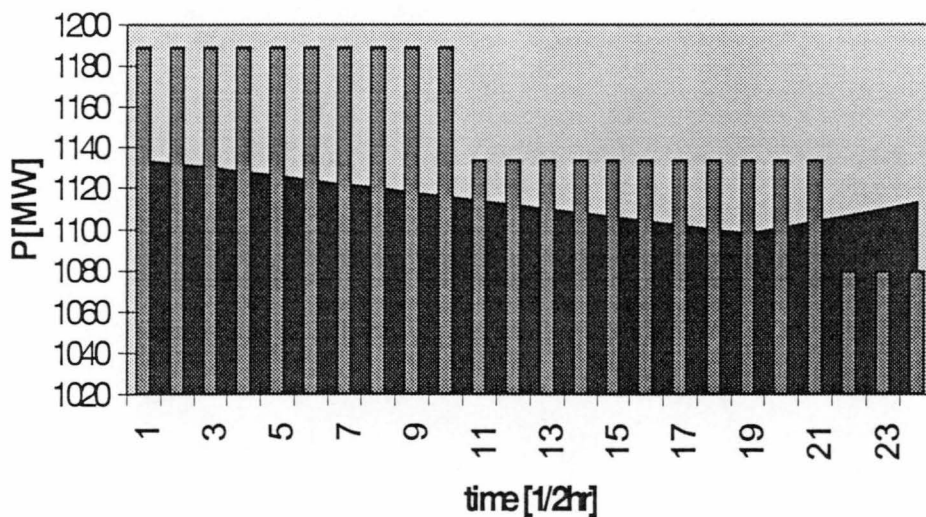

Figure 6.4. Original HSC plan

Two possible unit decommitment are shown in the Figure 6.5. and Figure 6.6. with different decommitment of the units. Figure 6.5. illustrates the case when actual inflow matches predicted inflow; the real-time decommitment decision is made on the basis that all unit maximum efficiency operation minimise deviation from the load curve.

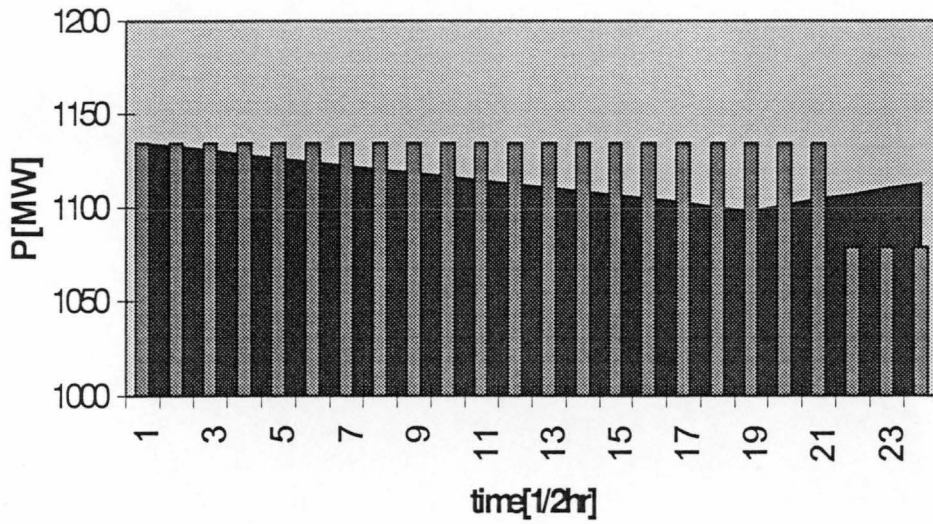

Figure 6.5. First option for decommitment

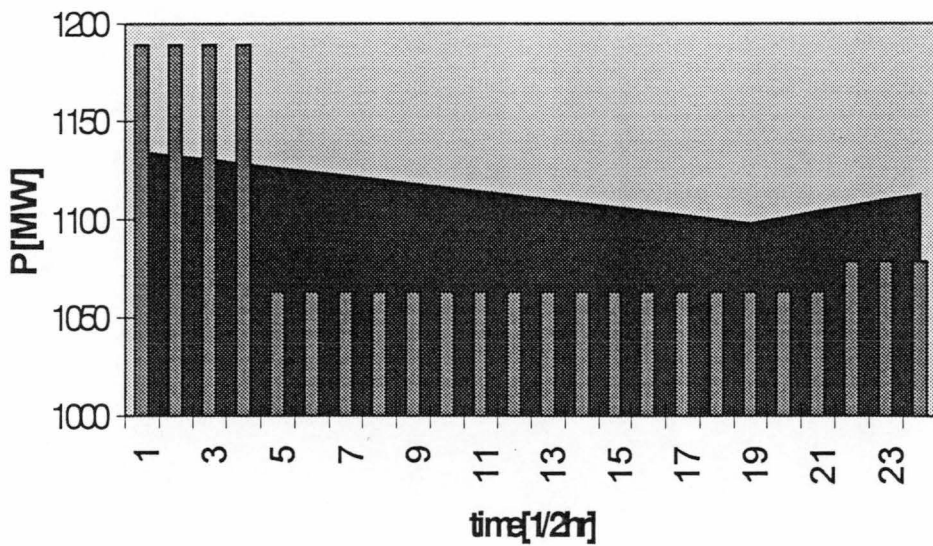

Figure 6.6. Second option for decommitment

Figure 6.6. illustrates the opposite situation where the actual inflow is less than predicted. This results shows that different decommitment is produced in effort

to adjust appropriate storage water usage, but still tries to minimise the mismatch between generation and load.

In real-time, generation has to meet the load and units have to deviate from maximum efficiency operation. On figure 6.7, an operation of a station is presented for the case where generation matches the load. Area represents maximum efficiency operation for the station and bars represent actual operation of the station.

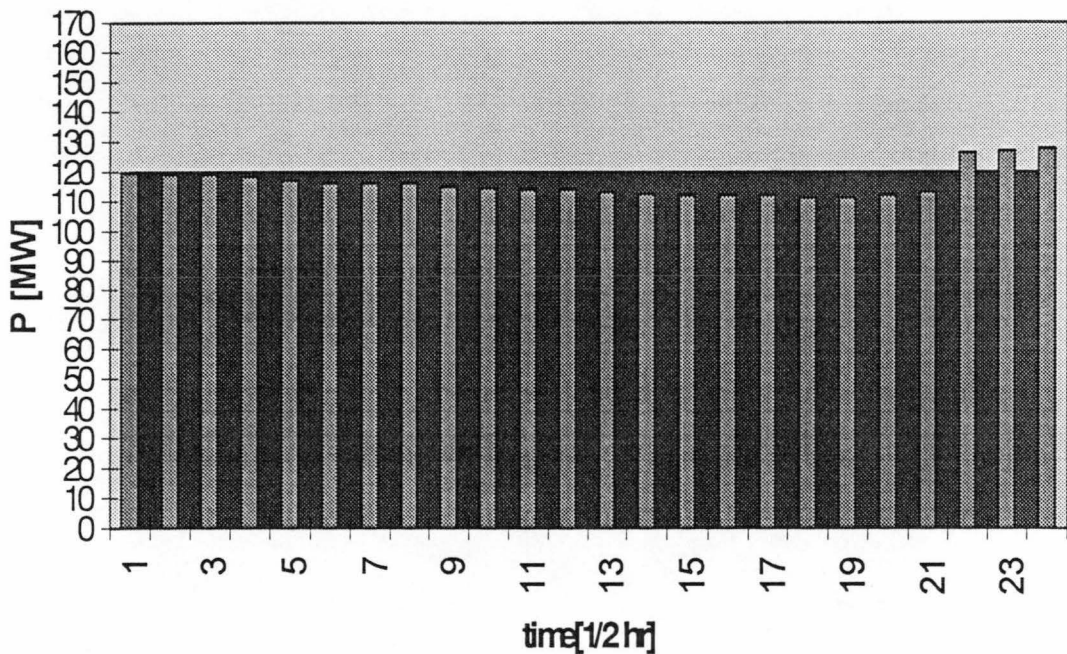

Figure 6.7. Operation of one station (Poatina)

Operation of the other stations have a similar pattern as the presented station and possible savings by this type of operation are shown on figure 6.3.

The other important flexibility of the algorithm is handling the accuracy of load prediction. With one unit frequency station the problem exists that other units have to be moved from efficient operation when load forecast is lower than actual load and frequency station operates on full gate, or when either the load forecast is higher than actual load and frequency station operates near zero.

Analysis of this example shows average savings of one percent when operating with new algorithm for load forecast errors of -1%, 0% and 1% .

Figure 6.8 shows commitment based on 50 MW extra load above on originally scheduled (figure 6.4).

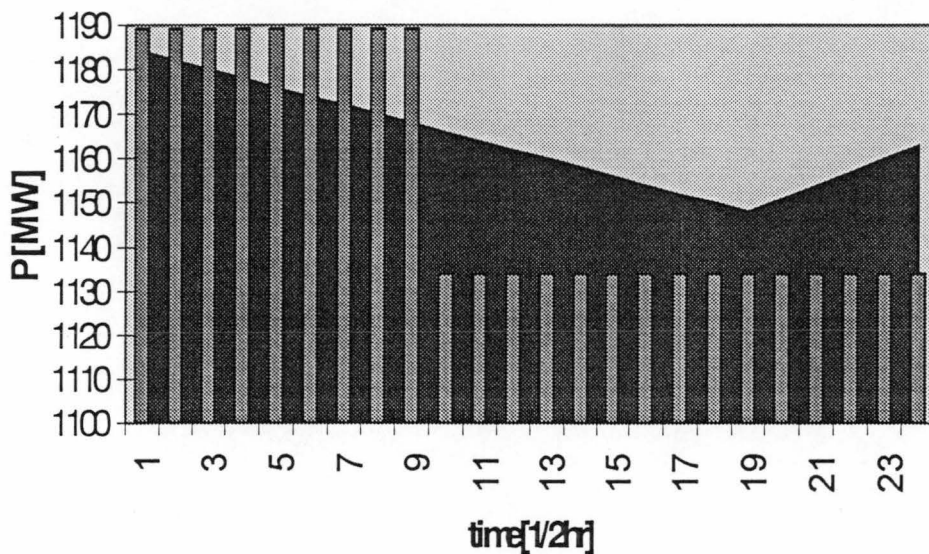

Figure 6.8. Extra 50MW load

These examples show that an exact match of the generation and load is not essential in the planning period. Better utilisation of the water can be achieved by leaving load/generation match for the real-time when load information is more accurate and better decommitment resolution can be achieved.

An additional important advantage of the new algorithm is head optimisation. As the head optimisation is a random process in the manual schedule, because the lack of time, in the following example only possible head savings are analysed.

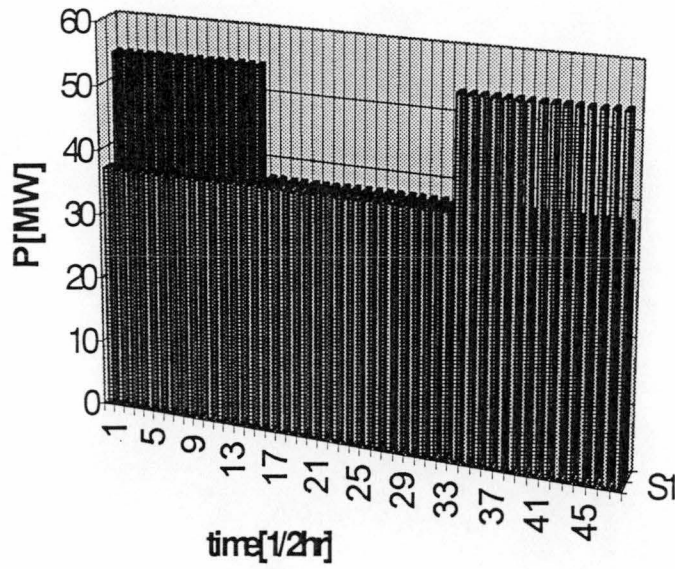

Figure 6.9. Different operation for the same energy

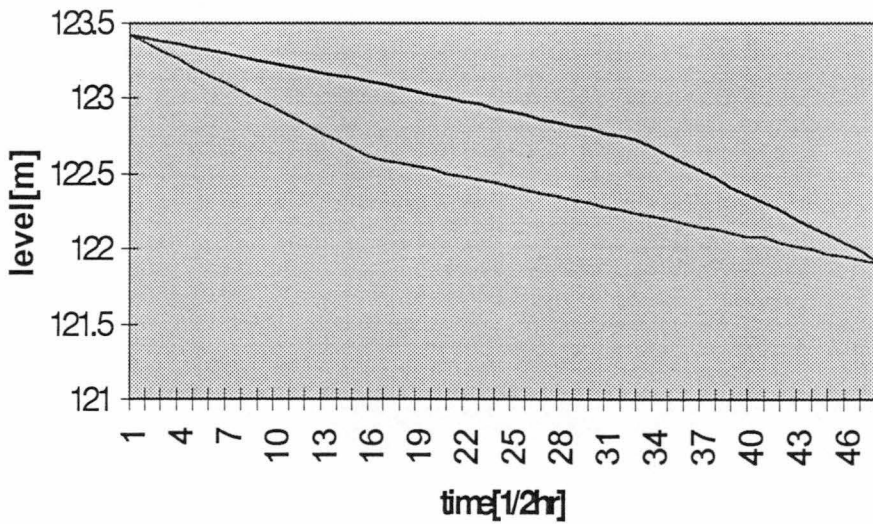

Figure 6.10. Lake levels based on different generation timing

In the same schedule a small storage unit is used to show an optimisation and savings based on the best head operation. Figure 6.9 displays an operation of the station according to the plan (front profile) and forced operation (back profile). On figure 6.10 lake levels are presented for both operations. It is obvious that operation according to the front profile operates on higher average head during the day what causes in extra energy production for the same amount of water or extra water in storage for the same energy production. Analysis shows that up to 1% extra energy can be produced at those stations based on head optimisation.

Relaxation of power balance and optimal operation of the system is justified by close connection between scheduling and real-time dispatch. As previously explained economic dispatch is dynamic dispatch closely connected with scheduling. Additional flexibility is ensured through rescheduling, as any significant change can be foreseen by economic dispatch and schedule can be reschedule on optimal way.

The overall concept of relaxed power constraint, head optimisation, close coupling between scheduling and dispatch and rescheduling feature should ensure optimal operation of hydro system. In the case of Hydro Electric Commission in Tasmania an estimate of the savings are up to six hours daily of an operators time plus up to 1% in annual stored energy savings. There is the possibility for further savings in mid-term optimisation by decreasing the risk of spill through better control of short-term storage levels.

6.3. Performance of the new algorithm

The algorithm is tested as the part of Energy Management System software on DEC Alpha 2100 computer.

Test case presented on figure 6.1 has 15852 rows, 41232 columns, 1160 integers and 110100 elements. The problem is solved first as a pure Linear Programming problem and with all the other Energy Management System processes on-line runs in 155 seconds. The solution is not acceptable for commitment/decommitment decision point of view. The same problem runs 1247.02 seconds for Mixed Integer Linear Programming. On Figure 6.11 the solution is presented for the previously introduced 'frequency station' in LP mode (area) and MILP mode (bars). Figure 6.12 and 6.13 present two other units in the system in LP mode(area) and MILP mode(bars).

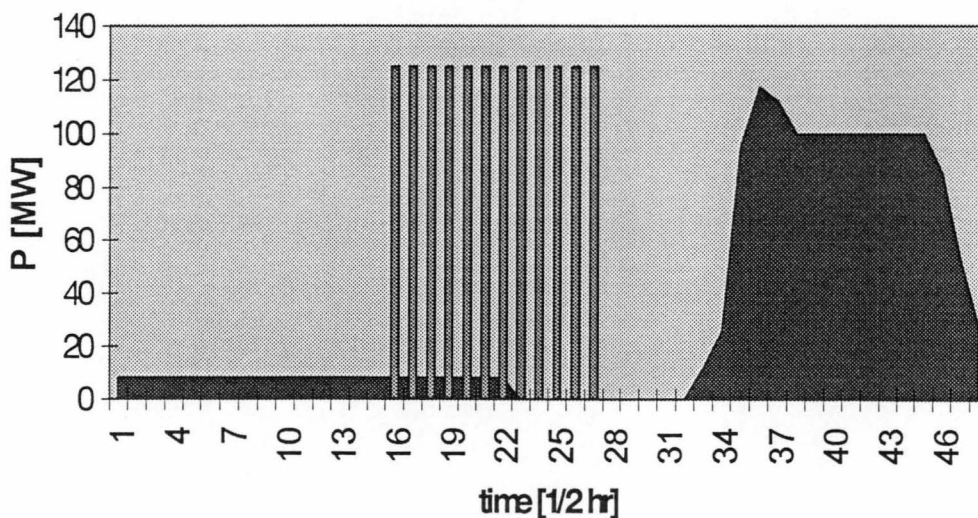

6.11. Operation of Gordon power station

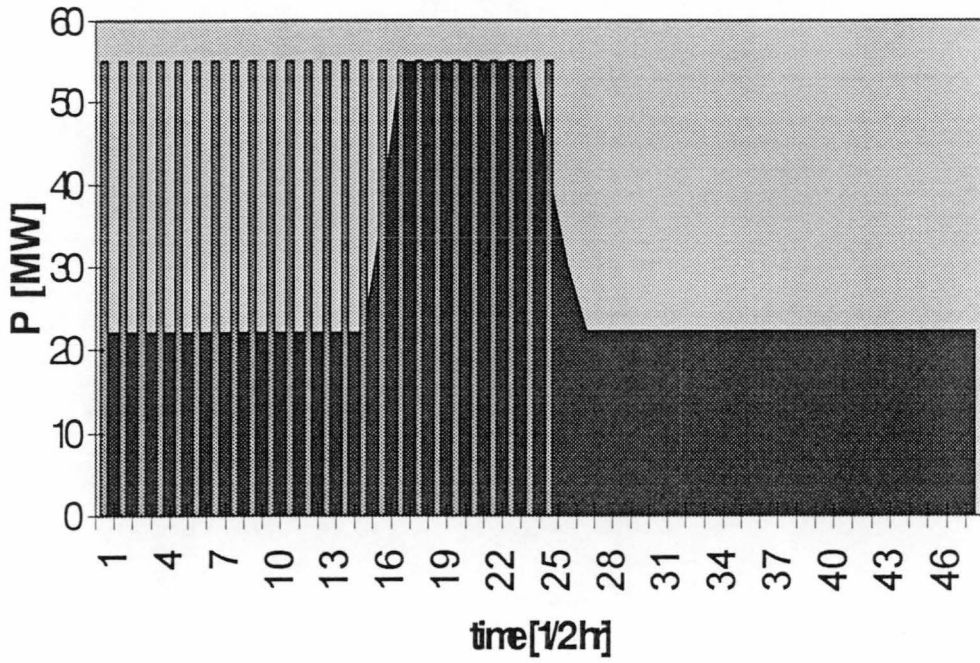

6.12. Operation of Devils Gate power station

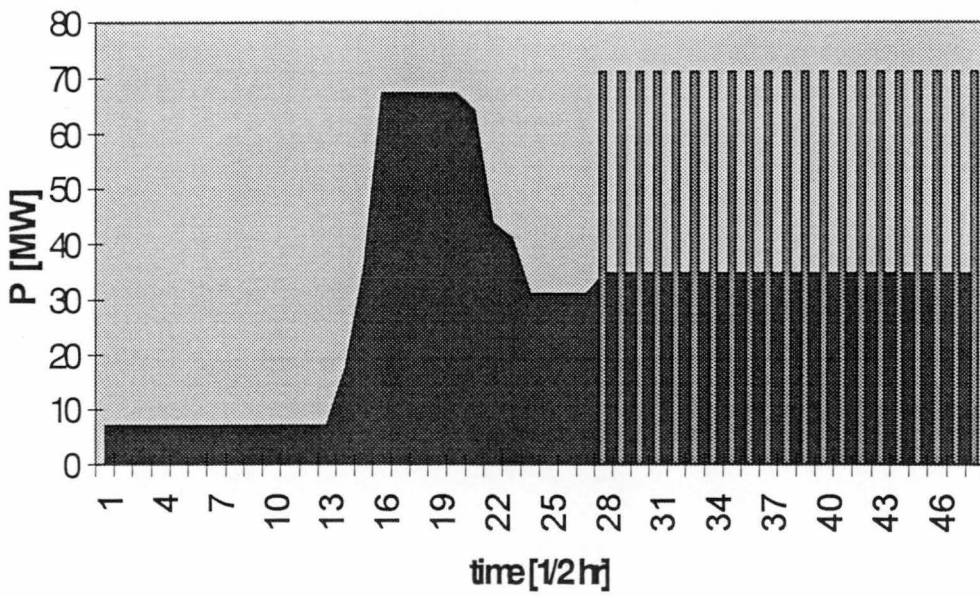

6.13. Operation of Anthony power station

The performance can fully satisfy operational requirements when the scheduling is performed for the following day. Because Dynamic Hydro Economic Dispatch algorithm has the a period of up to four hours, this performance is acceptable for rescheduling of the package.

Dynamic hydro economic dispatch solution is achieved in 35 seconds when dispatch is first time performed and in up to 1.5 seconds in tracking mode.

Those performances are achieved with normal operation of the rest of Energy Management System which makes the concept fully operational.

Chapter 7

Summary and Future Work

7.1. Results and Contributions

The subject of the research is scheduling and dispatch optimisation of the large scale hydro generation system.

In this final chapter the summary of the thesis is presented and the main achievements at the research are highlighted. Possible utilisation of the work is discussed and areas for future improvements are highlighted.

7.1.1. An overview

This thesis presents a short-term hydro scheduling and a real-time economic dispatch optimisation process for a pure hydro system. The thesis also discusses an implementation of the algorithm in the open electricity market environment and possible use of the algorithm for the optimisation of the hydro part of a mixed hydro thermal system.

A brief overview of short term scheduling, economic dispatch and different optimisation techniques used to solve the optimisation problem is presented.

A coordinated approach has been implemented in the real pure hydro system operated by the Hydro Electric Commission of Tasmania. Results show that a conservative savings estimate will be up to six hours daily of an operators time plus 0.5% in annual stored energy savings. There is the possibility for future savings in mid-term optimisation by decreasing the risk of spill through better control of short term storage levels. A comparison with historical generation statistics shows additional average savings of 0.3-0.4% per year based on the savings obtained from minimising the deviation from efficient operation and 0.4-0.5% savings based on the head optimisation.

The thesis presents original ideas in the area of coordination of different time horizons. It also introduces a new step toward real time orientation of the planning functions. It breaks the barrier of optimal plans which cannot be optimally implemented because of uncertainty in prediction, and economic adjustment in real time which does not give real economic benefits because they cannot optimise over the study period and follow a trajectory optimum. It constantly reschedules plans based on new real-time data which ensures optimal implementation by reducing dependency on predictions. It also looks ahead in the dispatch function which make this function behave more like an optimal planner and dispatcher rather than an economic adjustment. The Mixed Integer Linear Programming has been implemented in the scheduling process and start-up and shut-down have been properly treated in the large scale hydro system as well as the head optimisation.

The major contributions of the thesis are:

- Model improvements through power balance constraint relaxation, head optimisation and start up cost inclusion;
- Algorithm improvements through real-time coordinated approach of dynamic hydro economic dispatch and triggered rescheduling;
- Practical implementation on the real large scale power system.

7.1.2. Model improvements

Power balance constraint relaxation. Power balance constraint represents one of the most important constraint in any power system analysis as the generation has to satisfy the demand. However, this constraint is applied in short term scheduling based on forecasted load. In the case of hydro optimisation where flexibility of start and stop of the units represent the most important attribute, strict enforcement of power balance constraint presents significant reduction in short-term optimal hydro operation. The inaccuracy of load forecast and reduction in optimal hydro operation by enforcing power balance constraint are used as a basic argument for relaxation of the constraint to allowed optimal operation of the hydro plants. Dynamic economic dispatch accommodates the relaxation by checking in advance that load forecast is not far from the predicted and that relaxation is not far from original prediction. The objective function has a component which minimise this deviation of power balance constraint.

Head and start up cost. Modeling of the head variation presents one of the major problem in the hydro unit model. In many cases, head is assumed constant during a study period to overcome that problem, but in the case of large scale hydro system with many cascades and with a number of small storages which can change significantly over the period of one day (some of them over their full operational range), head optimisation becomes very important. In the thesis a

model is developed to take into account head variation and some initial results show that head optimisation can increase production up to 1% in some storages. As power plants on the small storages operate during whole year the savings can be significant. The thesis also includes start-up costs which are not significant compared to thermal plants, but they are operational cost.

7.1.3. Algorithm improvements

Dynamic hydro economic dispatch. A classic approach to economic dispatch is appropriate for the small deviations from calculated optimum. In the case of hydro optimisation two additional factors are important in the optimum dispatch algorithm: amount of water available for the day and flexibility to start/stop units when that is required by deviation from the calculated optimum. Both of the factors cannot be monitored only in moment to moment real-time operation. The dynamic approach is developed to allow better resolution of the unit commitment of hydro units and better monitoring storage levels to ensure adherence to short-term scheduled target levels.

Real-time scheduling. Dynamic hydro economic dispatch as explained above, can only accommodate monitoring and advance warning of deviation from the plan. The other important part of the algorithm is to produce a new optimal plan based on an actual condition. This is done by rescheduling which takes into account both actual condition/operation and the original optimal plan and produce a new optimal plan. This coordinated approach makes the whole function dynamic and moves short-term scheduling toward real-time scheduling.

7.1.4. Practical implementation

The major achievement of the thesis is the implementation of the model and algorithm on the real hydro system. Any hydro system in the world is unique, based on dam constructions, plant position, canal/tunnel connections and all sorts of special requirements, including other water users. Building the model and algorithm which will transfer all these specific requirements into general requirements, to satisfy any set of hydro plants, represents the main aim which is achieved in the thesis. The proposed model covers a wide range of possible specific hydro requirements and can be implemented on different hydro systems, from independent hydro generator with only few hydro plants to a large scale hydro system with complex multicascade power plants.

7.2. Future Work

The overall aim of the study is fully achieved. The algorithm and mathematical model are developed to ensure accurate short-term scheduling and real-time economic dispatch, but also to accommodate actual computer power and other software limitations. The algorithm and model are implemented in a real hydro system operation.

However, while the successful implementation represents the major achievement of the thesis, future improvements are possible. Further research can be conducted in the area of application of Mixed Integer Linear Programming software on this specific problem to provide a faster search for the optimal solution. As the integer variables represent the major problem in an integer optimisation search, substitution of those variables with a number of linear equations constraint will produce significant results.

Another area of research which will complement the thesis is the development of the mid-term and long-term mathematical models and algorithms and their incorporation in the overall hydro optimisation process.

The main area of future research is probably the area of generation operation in an open electricity market environment. This thesis has introduced only the existing algorithm as a tool to be used in the new power system environment. A number of studies can be conducted to analyse an optimum operation in different market environment regimes.

Appendix

A: Typical machine curves used in the model

Lake Cethana

Lake Cethana was created by the construction of a large 110 m high rockfill dam across the Forth River. The lake collects water from the Forth River and its tributaries, and water discharged by Lemonthyme Power Station and Wilmot Power Station. Figure 4-32 shows Lake Cethana's volume vs level characteristic and four levels that characterise each reservoir: MASL, NMOL, FSL, MFL. The long term simulation of the HEC's system defines two additional levels significant for the Lake Cethana operations: EOL and DOSL. Because of a varying pattern of inflow during a year, these two levels vary throughout a year as shown in Figure 4-33. To extract as much energy as possible from Lake Cethana, the lake's level should be kept between the EOL and DOSL levels.

Water accumulated in Lake Cethana is used to generate electricity at Cethana Power Station. Excess water in Lake Cethana is spilled into Lake Barrington. Figure 4-34 shows Lake Cethana Spillway's characteristic.

Reservoir Volume Model

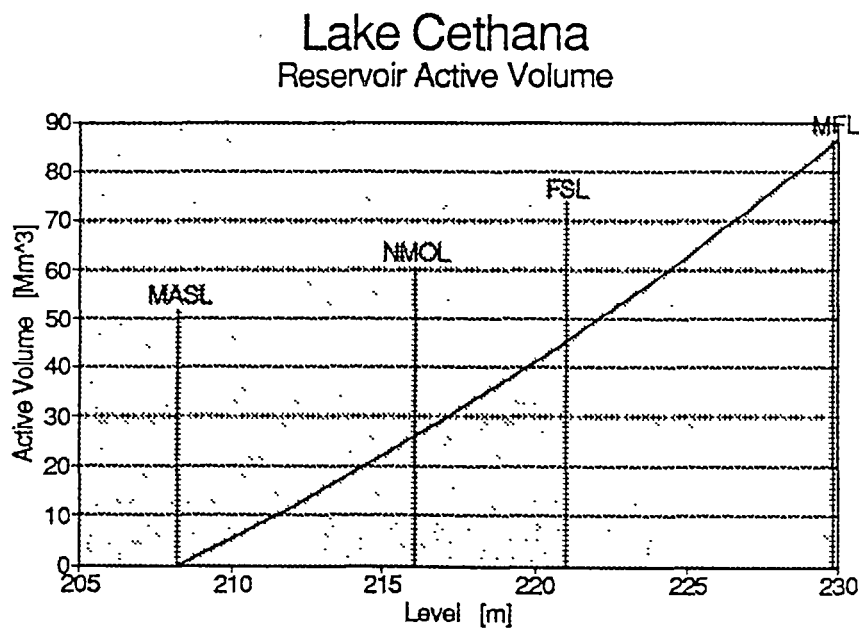

Figure 4-32. Lake Cethana volume vs level characteristic.

Source: Storage Control Production System (SCPS).

Storage Controls Constraints

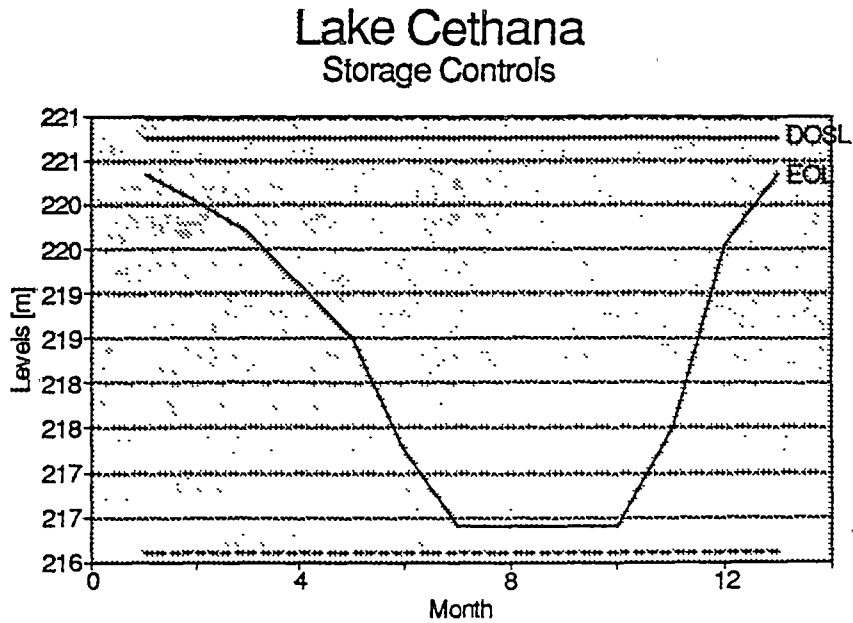

Figure 4-33. Lake Cethana EOL and DOSL Storage Controls (NMOL and FSL are also shown for reference).

Source: Data supplied in a graph form by John C. Wylie from Hydro Systems Investigation Department on 06-09-91.

Spillway Discharge Model

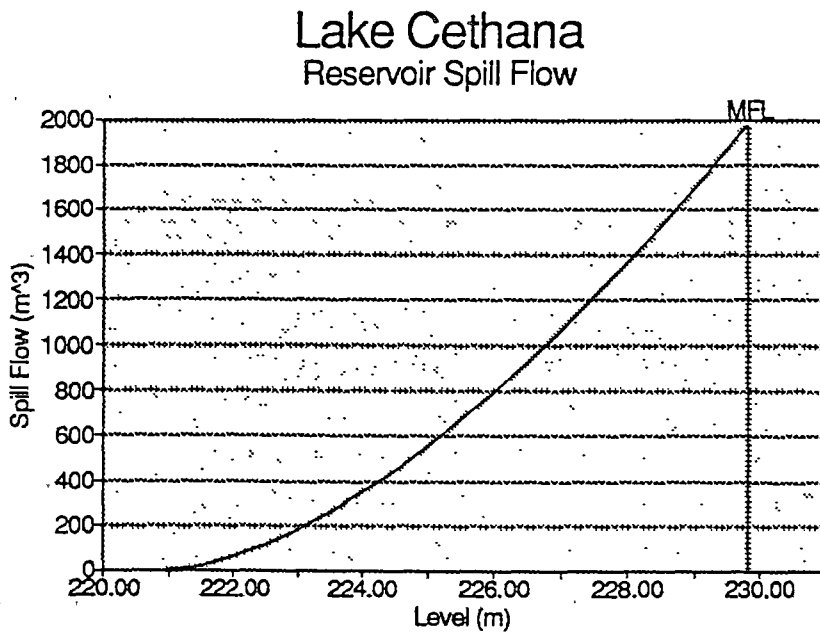

Figure 4-34. Lake Cethana Spillway Discharge.

Source: Hydrol.

Cethana P.S.

Water from Lake Cethana flows through a power tunnel leading to a single Francis turbine. Because of this single turbine configuration, the Cethana Power Station's total conduit head loss may be modelled as a single entity. Figure 4-35 shows Cethana Power Station's total conduit head loss as a function of power station discharge.

The Cethana Power Station's single Francis turbine is directly coupled to a generator with an installed capacity of 85 MW. Figures 4-36 to 4-39 show Cethana's turbine efficiency characteristic for various net head values. A polynomial function that may be used to model generator losses is described in Appendix C.

The Cethana Power Station's tailwater level is a function of the power station discharge, the level of Lake Barrington, and the spill from Lake Cethana. Figure 4-40 shows how the Cethana Power Station's tailwater level changes with the power station discharge.

Conduit Head Loss Model

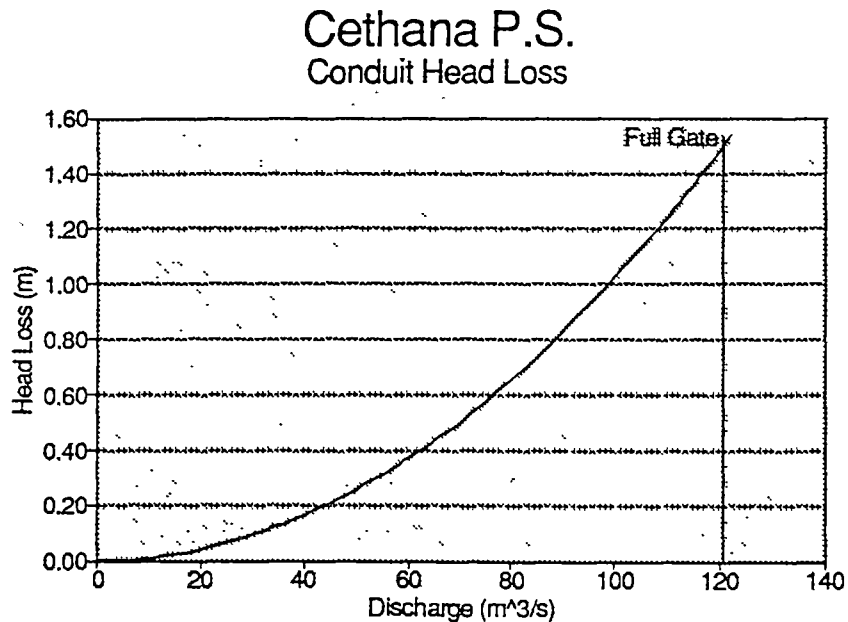

Figure 4-35. Cethana Power Station Conduit Head Losses.

Source: Data supplied by Max Williams.

Turbine Efficiency Model

Cethana Power Station Turbine Efficiency for Net Head 91.74 m

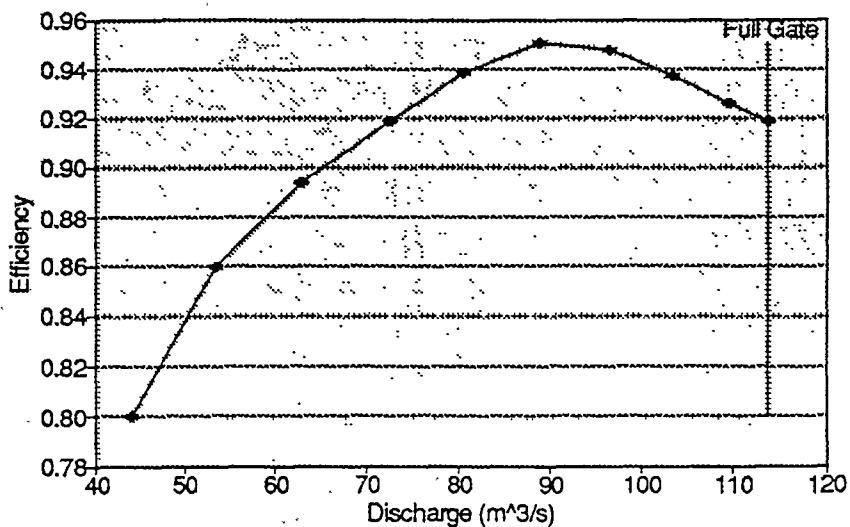

Figure 4-36. Cethana Power Station Turbine Efficiency for Head 91.74 m.
Source: Drawing 'HEC Tasmania, Cethana P.S. Converted Efficiency Curves of Prototype Turbine' (Document H410887).

Cethana Power Station Turbine Efficiency for Net Head 96.01 m

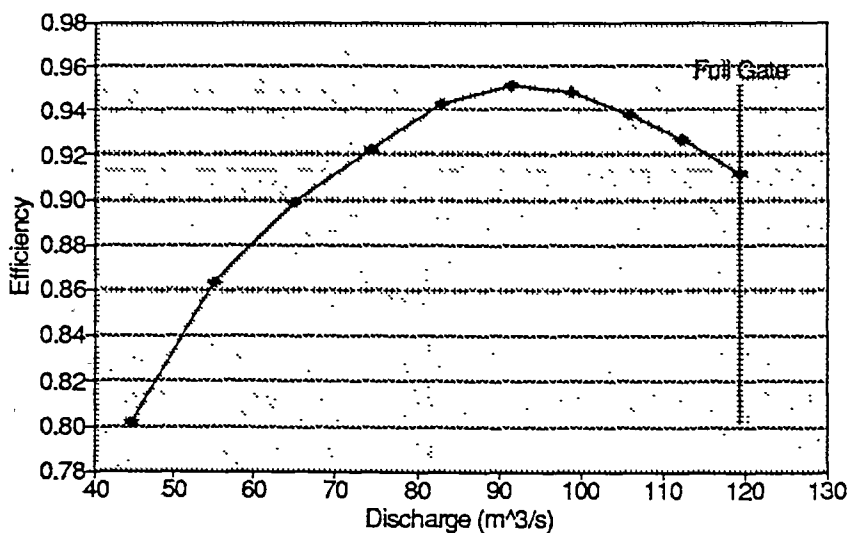

Figure 4-37. Cethana Power Station Turbine Efficiency for Head 96.01 m.
Source: Drawing 'HEC Tasmania, Cethana P.S. Converted Efficiency Curves of Prototype Turbine' (Document H410887).

Cethana Power Station Turbine Efficiency for Net Head 98.15 m

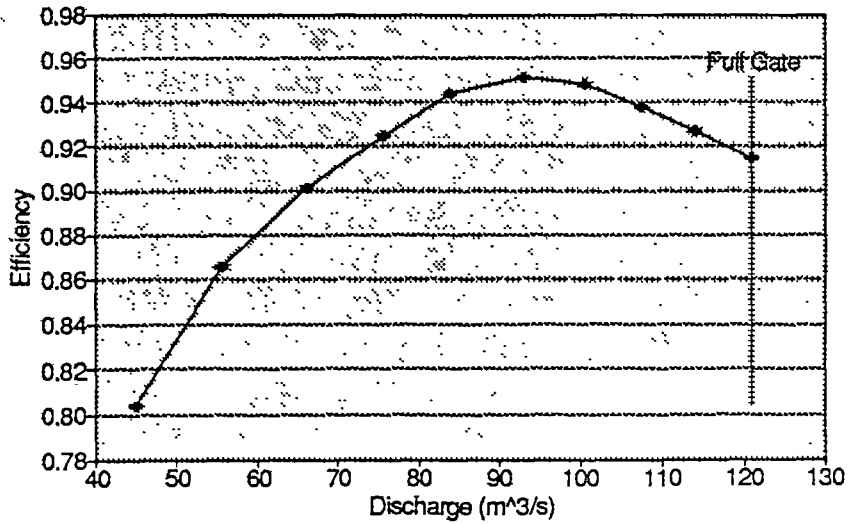

Figure 4-38. Cethana Power Station Turbine Efficiency for Head 98.15 m.
Source: Drawing 'HEC Tasmania, Cethana P.S. Converted Efficiency Curves of Prototype Turbine' (Document H410887).

Cethana Power Station Turbine Efficiency for Net Head 98.76 m

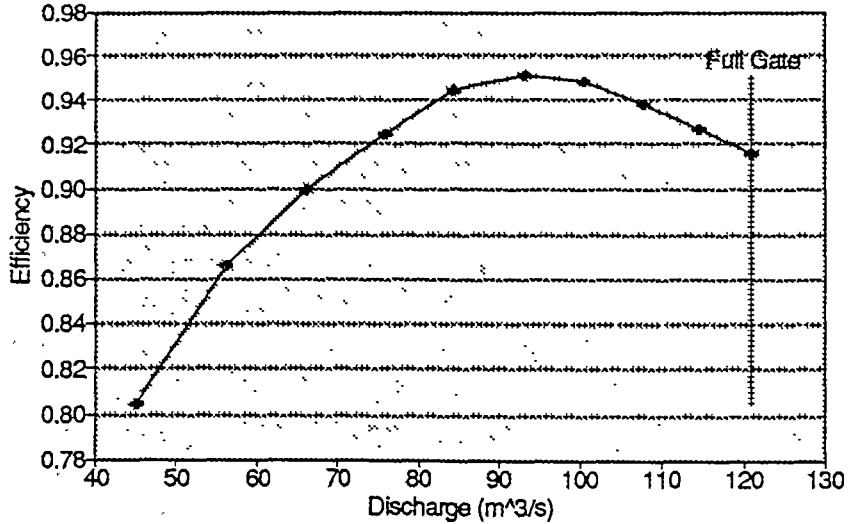

Figure 4-39. Cethana Power Station Turbine Efficiency for Head 98.76 m.
Source: Drawing 'HEC Tasmania, Cethana P.S. Converted Efficiency Curves of Prototype Turbine' (Document H410887).

Tailwater Level Model

Cethana Power Station Tailwater Level

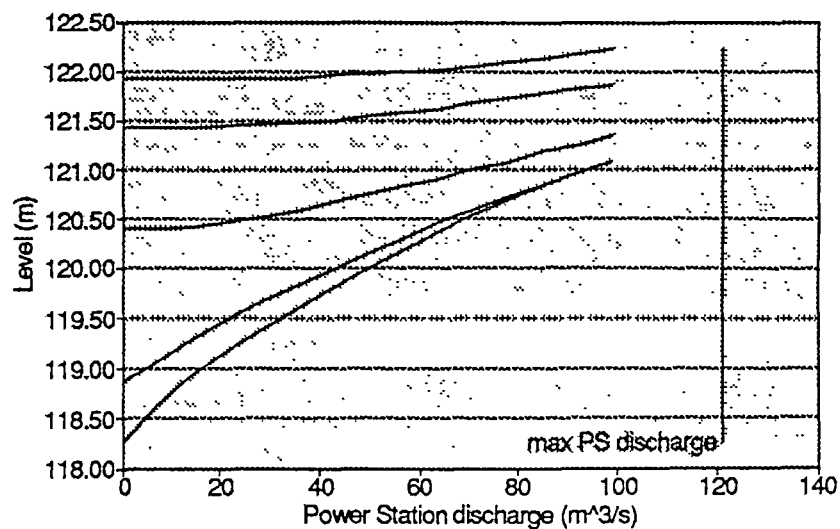
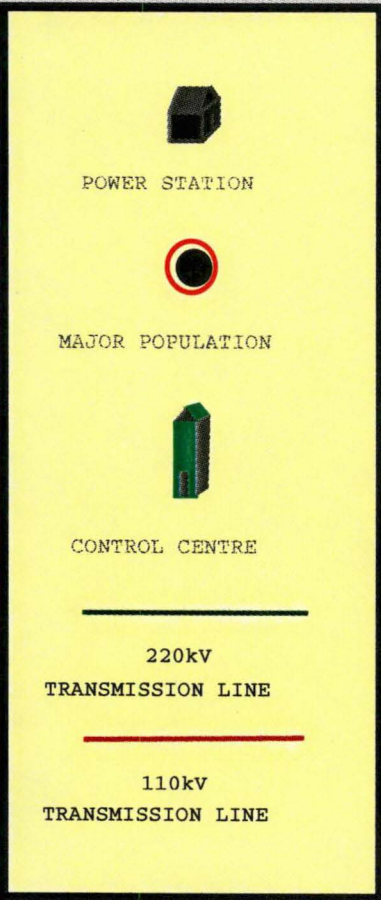
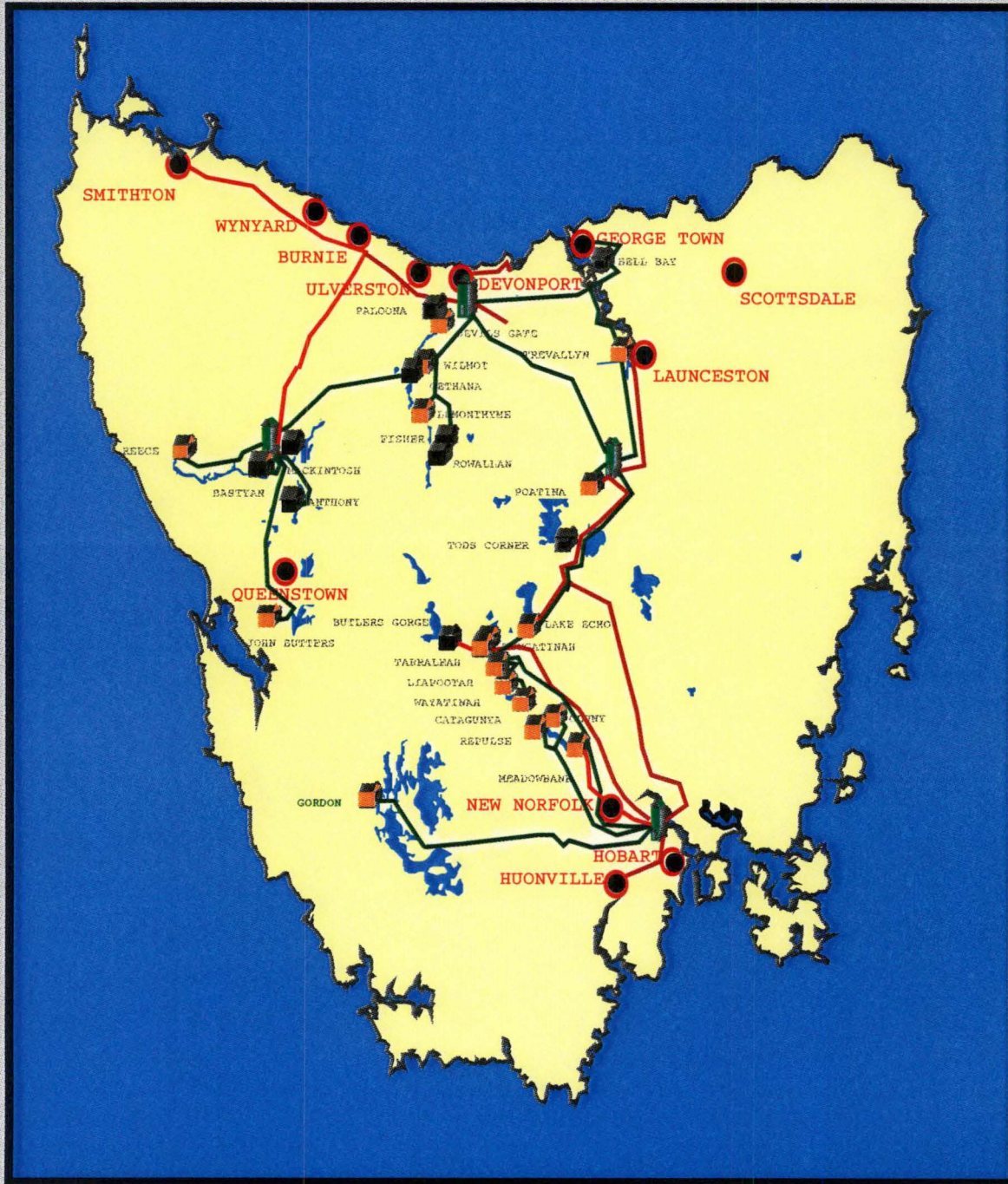

Figure 4-40. Cethana Power Station Tailwater Level for different Lake Barrington levels (from bottom to top): 118.26 m and below, 118.87 m, 120.40 m, 121.43 m, and 121.92 m.

Source: Drawing 'Cethana Tailwater Levels at Tunnel Portal' dated 06/04/70.

**B: Tasmanian map with power stations and
high voltage network**



C: Author's thesis based publications

A UNIQUE CONCEPT FOR HYDRO ECONOMIC DISPATCH

Nenad Tufegdžic, EMS Applications Engineer,
Hydro-Electric Commission, GPO Box 355D, Hobart 7001, Tasmania, Australia
Phone: (002) 30 55 41, Fax: (002) 24 32 06

Paul Hyslop, EMS Manager,
Hydro-Electric Commission, GPO Box 355D, Hobart 7001, Tasmania, Australia
Phone: (002) 30 58 04, Fax: (002) 24 32 06

Walter O. Stadlin, Principal Engineer,
Macro Corporation, 700 Business Center Drive, Horsham, PA 19044 2271, USA
Phone: (215) 674 2000, Fax: (215) 674 3464

ABSTRACT

This paper presents a unique hydro economic dispatch concept which will be applied to the Tasmanian electric system. Tasmania is an electrically isolated island state of Australia. The Tasmanian electric system is predominantly hydro with sufficient standby thermal capacity to cover extreme drought periods. The system is energy constrained rather than capacity constrained with a seasonal peak load of approximately 1450 MW and an installed hydro capacity of 2315 MW. The system is comprised of 40 interconnected storage facilities distributed among six catchment areas. There are 26 power stations consisting of a mixture of 54 Pelton, Francis, and Kaplan units. It became apparent during the design and specification of the new Energy Management System (EMS) for the Hydro-Electric Commission of Tasmania that some specific requirements of the Tasmanian system would require an alternative approach to classical economic dispatch.

INTRODUCTION

The EMS Generation Scheduling (GS) function is executed upon operator request and maximizes the effective use of available water. GS provides an operating plan for three to seven days in advance in time increments of 30 minutes, based on load and

hydrological forecasts and honoring electrical operational constraints. Unforecasted inflows and variable water travel times affect the real-time operation of the system. Therefore, the GS operating plan must be continually adjusted to account for actual conditions.

The new Hydro Economic Dispatch (HED) function is capable of looking ahead and is coordinated with the GS operating plan. HED executes every five minutes (adjustable up to fifteen minutes) or on demand, and looks ahead over a two hour interval (adjustable up to four hours) in time increments equal to the periodicity of the HED execution. Actual storage levels, stream flows, and rainfall are measured and telemetered to the EMS. HED produces unit base points for Automatic Generation Control (AGC) for On-Control units for the first time increment, unit output schedules for the remaining time increments, and storage level schedules for all time increments.

The inputs to HED are the same as for GS with the exception of unit availabilities. HED commits units for the remainder of the current half hour and the following full half hour. Only

those units that were committed (on/off) by GS in the current and next half hour are eligible for commitment by HED. The purpose of this 'front end' unit commitment is to obtain a better resolution of startup/shutdown times. The HED optimization problem is solved by a combination of successive model linearization, mixed integer linear programming, and heuristics all of which take into account the varying characteristics and constraints of the hydro units, hydraulic system, and electrical system. This unique concept for hydro economic dispatch is designed to make the most efficient use of Tasmania's hydro resources while providing reliable electric service.

PRESENT OPERATIONS

The Hydro-Electric Commission is the sole supplier of electricity in Tasmania which lies some 200 km south of mainland Australia. Although there are presently no electrical interconnections between Tasmania and the Mainland, the impact of a possible undersea HVDC link has been investigated [1]. Tasmania has a winter peak demand of 1450 MW and a summer peak demand of 1250 MW. More than 600 MW of this demand is constant throughout the year, being for bulk industrial users. The remainder varies on a daily, weekly and seasonal basis. The Commission has an installed base of 2315 MW of hydro capacity. It also has a reserve of 240 MW of oil fired thermal capacity which is used to support long term hydro fuel deficits. This reserve thermal capacity is used infrequently, being last used from November 1990 - May 1991. The Commission's system is energy constrained rather than power constrained and is unique because it is a predominantly hydro system.

The Commission's hydro system is spread over six separate catchments. Two of these catchments have head storages which are classified as long term; they have a life cycle of several years. The other four catchments have head storages which are classified as mid term; they have a seasonal life cycle. Four of the catchments also have downstream run-of-river (ROR) storages with life cycles that vary from a few days to less than 24 hours. Water travel times between ROR storages vary up to a maximum of 36 hours. Inflows also vary on an annual basis with rainfall which is normally heaviest in the winter months. Inflows can change rapidly during any particular day. If unseasonal rain occurs unexpectedly as is often the case in Tasmania, system conditions can change within one or two hours such that they will dramatically alter the operating plan. The system has a total of 26 power stations of which some are single unit and some are multiple unit. This gives a total of 54 units over the six catchments.

The operation of the Commission's system is based on meeting Tasmania's energy requirements on a long term basis. The long term objective of operating the system is to maximise effective water utilisation in a balanced manner across the system and minimise the use of the thermal reserves. When long term simulations of the system show that the long term availability of hydro to meet the annual energy requirements has fallen below a specified level then the thermal reserves are run to provide for the predicted energy shortfall. When a decision to run the thermal reserve is made it is then run on most efficient output continuously, normally for a number of months to allow the long term storages to be partially replenished. As stated

previously this decision is made infrequently and the thermal reserves may not run for up to ten years at a time apart from maintenance runs.

The two long term storages are operated as deficit storages. Both storages have large power stations associated with them and if downstream ROR storages are included, water released from these storages can supply 800 MW. The mid term storages are governed by a mid term operating policy (updated monthly). The objective of this policy is to provide water coordination across the catchments and make adjustments for seasonal factors and planned maintenance. System scheduling and unit commitment is presently performed daily by System Operation using this mid term operating policy. System Operation is required to commit up to 16 stations daily. The objective of the short term operating policy is to maximise the generation of energy from the water used, by operating plants as close to maximum efficiency and maximum head as is possible.

The Commission has an existing EMS which includes supervisory control and data acquisition (SCADA)/AGC and constrained classical HED. This system will be replaced by a new EMS, including SCADA, AGC, HED, Hydro Scheduling and Unit Commitment, Power System Analysis applications and an Operator Training Simulator. The preparation of the Specification for this new EMS commenced in 1991. The new EMS is scheduled for delivery in March 1995. The authors developed the new concept for HED to overcome some specific problems experienced with existing hydro-electric system operations.

THE EXISTING HED APPROACH

The existing HED calculates the optimal system allocation for despatchable generation, taking into account all hydraulic and electrical constraints. The HED function provides two main features:

- ◆ Water coordination for the storages on level control, and
- ◆ Economic dispatch for machines which are under HED's control.

The water coordination feature performs well and will be retained in the new EMS. The economic feature, however, does not perform as required because of its inability to take into account the following specific characteristics:

- ◆ Inflows are strongly dependent upon rainfall which means that the predictions of the amounts and the time of their peaks are often inaccurate, and
- ◆ The optimal use of water is to operate turbines at their most efficient operating point and on maximum head.

Short term (daily) scheduling creates an operating plan to maximise the energy generated from the water available for generation. This plan schedules plants to operate on maximum efficiency and maximum head based on the load forecast and inflow predictions. HED has the task of economically adjusting the operating plan to account for the difference between the predictions and real time data. This is a very difficult task because of the number of ROR stations and changeable inflow. In many cases head optimisation and maximum efficiency operation have opposing tendencies in real time. Another problem is the inability to pass

information from the short term scheduling plan to the HED function.

HYDRO DISPATCH PROBLEM EXAMPLES

Wilmot power station (Mersey Forth catchment) illustrates the hydro dispatching problem. The station consists of a single Francis unit and is ROR with a storage life cycle of four to six days and is the first in a cascade. Figure 1(a) shows the inflow prediction for Wilmot's storage (Lake Gairdner) for a study period of 24 hours. Figure 1(b) shows the operating plan for Wilmot station for the same period. Figure 1(c) shows the variation in the level of Wilmot's storage during the study period based on the predicted inflow and planned power station discharge. This storage level profile which is produced from the operating plan is used as the target level for HED.

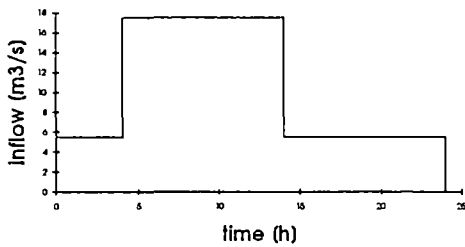

Figure 1 (a)

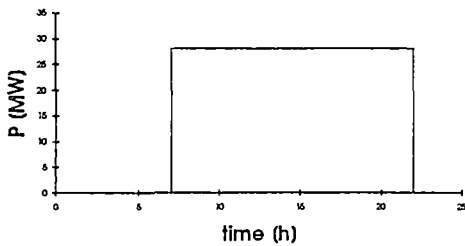

Figure 1 (b)

As inflow forecasting is a very difficult task because of the changeable weather in Tasmania the size and time of the predicted inflow peak is often inaccurate. In Figure 2(a), curve

number 1 (repeated from 1(c)) is the target level for HED based on predicted inflow, curve number 2 represents the level of Wilmot's storage

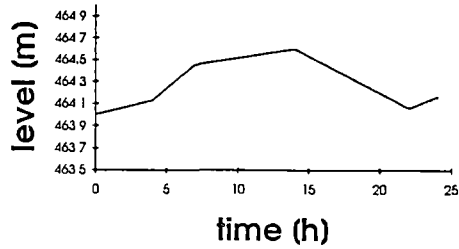

Figure 1 (c)

over the study period with an average increase in inflow of 10%, and curve number 3 represents the level of Wilmot's storage with a 10% increase in inflow and 3 hours delay of the peak with Wilmot running on the same power output as scheduled.

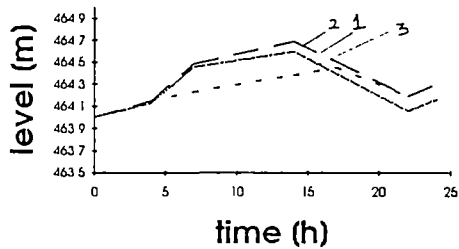

Figure 2 (a)

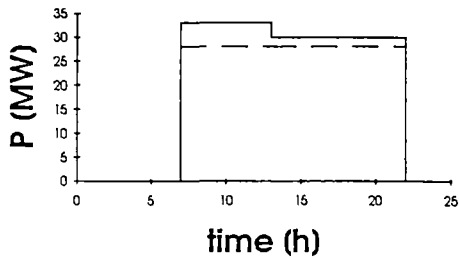

Figure 2 (b)

Target levels in the ROR storages are very important and for short term scheduling they are provided by the mid-term operating policy and are based on the probability of spill. The existing HED must ensure that the storage level satisfies the target level at the end of the study within defined

deadbands. An increase in average inflow by 10% through whole study period is the simplest of all problems to

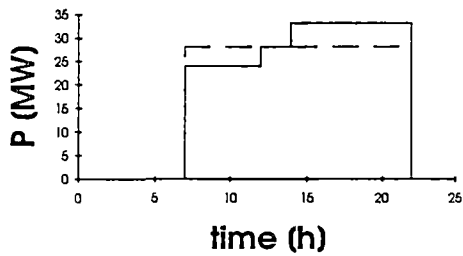

Figure 2 (c)

consider. The existing HED will adjust the power output schedule for Wilmot station as is shown in Figure 2(b) which is economically unacceptable because it is forced to operate away from the maximum efficiency point of the turbine. The problem becomes more complex if the inflow peak is delayed for some period. The HED adjusted power output schedule for Wilmot station is shown in Figure 2(c) which is again economically unacceptable. These examples show that it is very difficult to handle any changes in inflow in an economical way with the existing classical HED.

Another problem with the existing HED relates to the load curve. An operating plan for a one hour period during the climb to the morning demand peak on the Tasmanian system is shown in Figure 3(a).

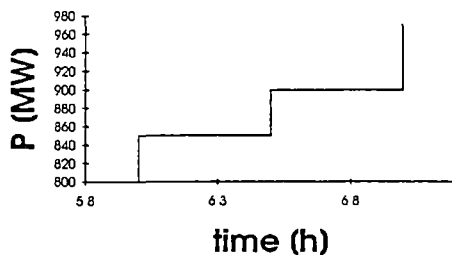

Figure 3(a)

The actual demand is shown in Figure 3(b) and the shadowed area shows the part of the demand which needs to be

economically covered with HED. Meeting this demand with a predominantly hydro system means moving stations from maximum

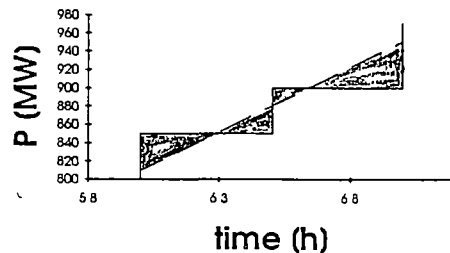

Figure 3(b)

efficiency. To maximise economic operation of the system it is important to minimise the difference between the operating plan and the actual demand because this difference is the amount that the units will be moved from their maximum efficiency operating point. The existing HED is unable to reduce this difference.

The above problems mean that while the existing HED can be used for water coordination of the storages on level control and for storages where level variation is not important in terms of the operating plan, only 50% of the hydro stations can be placed on HED control.

THE NEW HED APPROACH

Experience and problems with the existing HED prompted a new approach for the new EMS. The following additional features will be included in the new HED function:

- ♦ A capability to 'look ahead' so that HED can economically adjust the operating plan in a smooth manner while at the same time maintaining the

objectives of the operating plan.

- ◆ A capability to economically adjust the operating plan for inaccuracies in the prediction of inflow and the occurrence of its peak.
- ◆ A capability to commit units early or late with a resolution of less than 1/2 hour.

Figure 4 is a block diagram showing the new HED concept.

HED provides a bridge between Automatic Generation Control (AGC) and the Hydro Scheduling and Commitment (HSC) functions. HSC develops a future half-hourly schedule for units and storages based on forecasts of inflow, load, hydraulic and electrical system conditions and the given unit availability from the Outage Scheduler. AGC sends control to the

generating units in order to maintain system frequency and to drive the units to their desired outputs. HED needs to execute every five minutes (adjustable up to 15 minutes) to produce unit base points for AGC for On-Control units and to provide effective water coordination between storages with short water travel times. HED can be also executed on user demand. The 'look ahead' study period for HED is 2 hours (adjustable up to 4 hours). HED provides a real time adjustment of the HSC developed operating plan by looking ahead over the study period and providing an updated schedule of unit base points in time increments equal to its execution periodicity. HED produces:

- ◆ Unit base points for the first HED time increment which are passed to AGC.

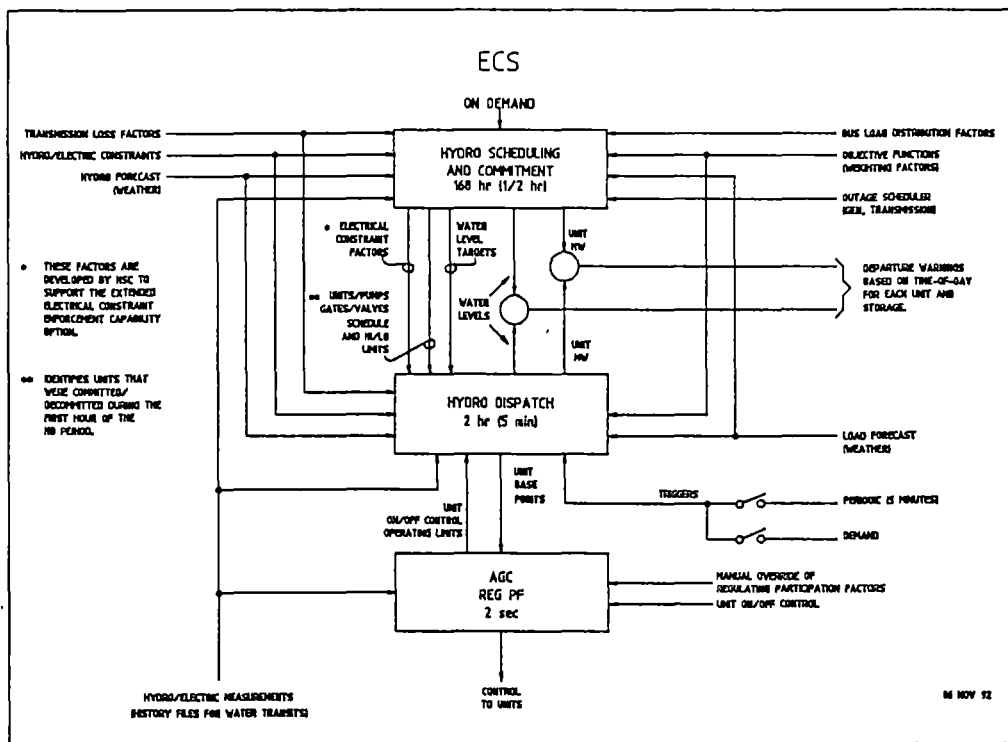

Figure 4

- ◆ Unit output schedules for each of the remaining HED 5 minute time increments.
- ◆ Storage level schedules for the HED study period.
- ◆ Better unit commitment resolution.

Inputs to HED will be the same as those for HSC with the exception of unit availabilities. Storage levels for the first time increment are provided by real time telemetry and for the last HED time increment from the HSC developed operating plan. To avoid possible infeasibilities, these HSC levels are treated as soft constraints with adjustable violation penalties. HED will need to commit units for the remainder of the current half-hour interval and the following full half-hour interval. Only those units that were committed by HSC in the current and next half hour will be eligible for commitment by HED. The new HED will also compare differences between the HSC and HED operating plans and in the case where these differences exceed a specified threshold HED will trigger HSC to execute to produce a new operating plan

The problems with the existing HED can be solved with the new HED. The ability to pre and post commit units will mean that the operating plan's unit generation steps will more closely match the real time system load. Figure 5(a) shows how HED will pre and post commit units for the same demand curve and operating plan that is shown in Figure 3. The shadowed area is reduced and the difference between the operating plan and the actual demand is minimised which provides much better economic results.

Any pattern of real time load can be handled using this method as is shown

in Figures 5(b) and 5(c) to provide real economic improvements through better utilisation of the water. The decision to pre and post commit units is based on the real time situation in the system.

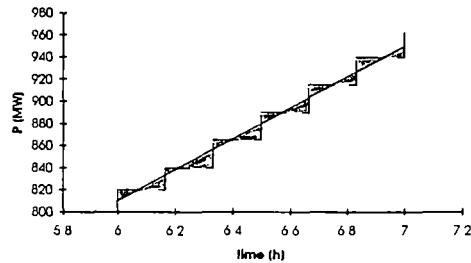

Figure 5 (a)

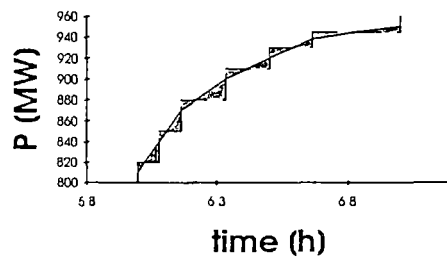

Figure 5 (b)

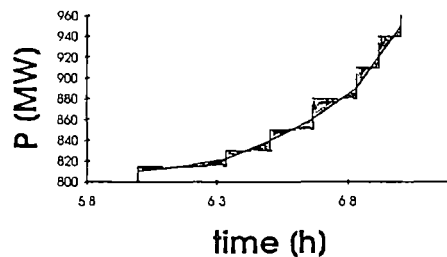

Figure 5 (c)

In relation to the case where an increase in inflow into Wilmot storage occurs, Wilmot station will be considered first for pre commitment. Where stations have less inflow than predicted post commitment will be considered. If a system wide increase in inflows occurs the order for commitment will depend on the previously defined target level deadbands. If the error in inflow exceeds a defined threshold in terms of target levels at the end of the 4 hour

study period HED will trigger an execution of HSC to provide an updated operating plan. Figure 6(a) shows how the 'look ahead' and pre-commitment features would alter the operation of Wilmot station for the case shown in Figure 2(a) of a 10% increase in inflow into Wilmot storage. The level of Wilmot's storage for the changed operations is shown as curve 1 in Figure 6(b). Curve 2 shows the target level for Wilmot's storage from the original operating plan (refer Figure 1(c)).

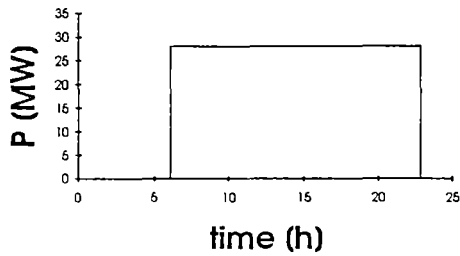

Figure 6 (a)

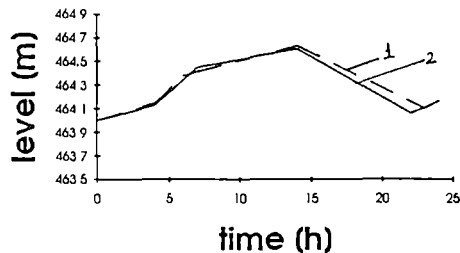

Figure 6 (b)

In Figure 6(b) it can be seen that with the new HED and post commitment based on a 4 hour study the altered unit decommitment accounts for the inflow error and allows for a better storage level target achievement.

CONCLUSION

The classical approach to HED cannot cater to the dynamic characteristics of the Tasmanian hydro-electric system. For this reason a unique approach to HED has been designed by the authors

to satisfy all requirements and improve the real time economic operation of the Commission's system. The features which make the HED unique are its capabilities to 'look ahead' and to pre and post commit units in the system. This gives the following benefits for the Commission's system:

- ◆ Better water utilisation.
- ◆ An effective way of handling inaccuracy in the inflow predictions.
- ◆ The possibility to handle larger inflows than predicted without revising the operating plan.
- ◆ More effective storage level control.

This new HED concept was designed to satisfy the specific requirements of the Commission's predominantly hydro system. The authors believe that some of the ideas can be implemented in any HED which includes hydro power plants in cascade, in order to achieve both economic benefits and better water utilisation and control.

References

- [1] M.R.Piekutowski, T.Litwinowicz, R.J.Frowd, "Optimal Short-Term Scheduling for a Large-Scale Cascaded Hydro System", Proceedings of the 1993 IEEE Power Industry Computer Applications Conference

A COORDINATED APPROACH FOR REAL-TIME SHORT TERM HYDRO SCHEDULING

Nenad Tufegdžic
Hydro Electric Commission
Hobart, Australia

Roderick J. Frowd, Member
Consultant to Landis & Gyr
Energy Management,
San Jose, CA

Walter O. Stadlin, Life Fellow
Macro Corporation,
Horsham, PA

Abstract The paper describes a coordinated approach to short-term hydro scheduling and dispatch that has been developed as a part of the Tasmanian Hydro Electric Commission's (HEC) new Energy Management System (EMS), which is being delivered by Landis and Gyr Energy Management.

Tasmania's hydro generation system consists of 40 reservoirs in six river catchments. The daily water release for each plant is scheduled using the HEC's mid-term operation policy.

The Hydro Scheduling and Commitment (HSC) function schedules the hydro units on a half hourly basis so that the allocated water release maximizes the energy production. This maximization of energy production is achieved by maximizing the head and this ensures that operation is always as close as possible to maximum efficiency. Mixed Integer Linear Programming is used with a detailed model of the interconnected hydro system to determine the half-hourly operation schedule.

The Hydro Economic Dispatch (HED) function is used to implement the schedules produced by HSC in the real-time operation. The HED also uses a detailed model of the hydro system with a Linear Programming algorithm to ensure that each unit operates as close as possible to its head-dependent theoretical maximum efficiency point while meeting the desired storage levels specified by the HSC solution.

HSC and HED have been tested against a number of operational scenarios and when it is fully integrated within the new EMS it is expected to yield annual stored energy savings up to 0.5% through more efficient hydro-electric system operation. It is expected to also provide additional savings by fostering improvements to the mid-term operating plan.

96 WM 169-3 PWRS A paper recommended and approved by the IEEE Power System Engineering Committee of the IEEE Power Engineering Society for presentation at the 1996 IEEE/PES Winter Meeting, January 21-25, 1996, Baltimore, MD. Manuscript submitted July 27, 1995; made available for printing January 10, 1996

I. INTRODUCTION

Tasmania is an island state of Australia with a hydro plant generation installed capacity of 2350MW and sufficient standby thermal installed capacity of 240MW to cover extreme drought periods. The hydro system consists of 40 interconnected storage reservoirs within six catchment areas. There are 26 hydro power plants with a total of 54 units.

The daily hydro scheduling process commences with the application of the mid-term operating policy to determine the amount of water to be released from storages to meet the daily forecasted energy requirement. This allocation of energy is performed using a set of rules to transfer mid-term planning into short-term scheduling constraints taking into account inflows and load forecast.

The result of this daily energy allocation process is a set of daily water releases for each unit. The HSC function is then used to optimally schedule these units to maximise the energy production using the pre-defined water release.

The power balance constraint has been relaxed and unit models developed with the assumption that each unit is operated at its maximum efficiency point wherever possible so that maximum energy is obtained from the released water. Another operational constraint is that, where units are scheduled to operate less than 24 hours per day, they are normally scheduled so that they operate for a single contiguous period during the day, i.e. only one start-up and shut-down is permitted each day.

The half-hourly unit commitment problem then becomes a problem of finding the combination of periods which maximises turbine efficiency operation. During this scheduling process, a detailed model of the reservoirs and flow paths which comprise the hydro system is used so that the effects of the unit schedules on the reservoir levels, spill flows and other flows in the hydro system are fully modeled.

The half-hourly unit commitment schedule produced by the HSC function is implemented in real-time using the HED

function. In the case of the HEC system, where most plants are part of a tightly coupled cascade, the HED is performed using a detailed model of the hydro system so that all reservoir and flow constraints are respected during the dispatch. This function also provides a look-ahead capability by performing a dispatch solution for up to 4 hours ahead using a 5 minute time increment. This ensures that economic adjustments of the HSC operating plan occurs in a smooth manner while still maintaining the HSC objective with added capability to commit/decommit units within the resolution of five minutes. It also provides early warning when the real-time conditions deviate from forecasts and that a reschedule of the HSC function is necessary. The close coupling between HSC and HED including feedback for rescheduling makes the overall optimisation concept more dynamic and real-time oriented.

II. FUNCTIONAL HIERARCHY

The Hydro Scheduling and Commitment and the Hydro Economic Dispatch functions may be divided into three hierarchical levels. This functional hierarchy is illustrated in Figure 1.

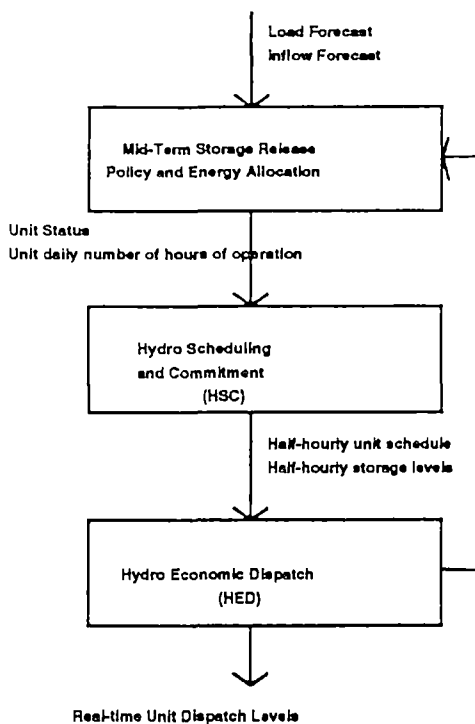

Figure 1 HSC/HED Hierarchy

The HSC function executes on a daily basis at midnight for the next day and up to 8 future days.

The HED function economically adjusts the unit dispatch points based on telemetered real-time data. This real-time dispatch adjusts the dispatch points of the units for the discrepancy between the actual load and the forecast load used in the HSC solution. If this difference between the telemetered load and the forecast load exceeds a threshold, a new HSC calculation is triggered to adjust the commitment for the new load levels.

HED executes for a period of up to 4 hours so that the plant may be scheduled to smoothly follow the reservoir target levels set by the HSC function. If the target levels set by HSC cannot be achieved, a warning is issued so that the HSC function may be re-run to define a new set of achievable target levels. This capability is particularly important for the case when the forecast inflow changes for the cascaded run-of-river plant.

III. HALF-HOURLY UNIT COMMITMENT

A. Problem Definition

Following allocation of energy and water releases using the mid-term storage release policy (called the Energy Allocation phase), the HSC function then schedules and commits available units for the current and the following 24 hour periods using a half hour time increment.

The objective of this phase of the calculation is to schedule units to operate at a high efficiency while using the required amount of water based on inflow prediction and minor and major storages release. The Energy Allocation phase determines the number of hours of operation at maximum efficiency for most of the run-of-river stations. These hours of operation are determined using an average conversion factor for a nominal head level.

The HSC optimization problem is to fit the blocks of energy determined by the Energy Allocation phase under the daily load curve so that as many plants as possible operate at maximum efficiency and wherever possible operate downstream plants at higher heads so that their overall water to energy conversion rate is maximized. Another constraint imposed on the commitment of the units is that they operate for the desired number of hours with only one start-up and shut-down per day.

This objective is realized using a special set of constraints in the unit model that forces the unit to run at maximum efficiency wherever possible. The operation at a higher head level is encouraged by using unit merit factors, derived from the unit's overall efficiency variation with head level, in the objective function.

Mixed Integer Linear Programming (MILP) was chosen [1] as the solution algorithm for this problem, because the linear programming part models the hydro network very effectively and the integer variables can be used to control the unit start-up and shut-down behavior.

B. Mathematical Formulation

Variable Definition

The following variable notation is used to define the constraints.

$Q_{ij,t}$ = flow rate on branch between node i to node j in time increment t [m^3/s]

$Q_{TH_{ji,t-\tau_{ji}}}$ = branch historical flow prior and during the study for actual time increment [m^3/s]

$Q_{0,ij}$ = flow linearisation constant [m^3/s]

$b_{i,t}$ = inflow into reservoir [m^3/s]

$s_{k,t}$ = volume in reservoir k at time increment t [Mm^3]

$P_{n,t}$ = net generation by unit n in time increment t [MW]

D_t = load forecast in time increment t [MW]

$q_{n,t}$ = water flow rate for unit n in time increment t [m^3/s]

$u_{n,t}$ = unit n on/off (0,1) status variable for time increment t

$y_{n,t}$ = unit n start-up variable (0,1) for time increment t

$z_{n,t}$ = unit n shut-down variable (0,1) for time increment t

α = linearisation constant

$W_{up,t}$ = slack variable for power balance constraint [MW]

W_{FIX} = deadband for power balance relaxation [MW]

$A_{up,n}, A_{dn,n}$ = constants obtained from power/discharge curve [$m^3/s \cdot MW$]

Node Water Balance Equality Constraint

For each node except for the discharge node [2]:

$$\begin{aligned} \sum_{ij} Q_{ij,t} + (s_{k,t} - s_{k,t-1}) \cdot (10^6/3600) = \\ = b_{i,t} + \sum_{ji} Q_{TH_{ji,t-\tau_{ji}}} \end{aligned} \quad (1)$$

High and Low Limits

For the reservoir level and branch flows [2]:

$$s_{\min,k,t} < s_{k,t} < s_{\max,k,t} \quad (2)$$

$$Q_{\min ij} < Q_{ij} < Q_{\max ij} \quad (3)$$

Spill and Reservoir Target Level Constraints

Separable Programming is used to model the piecewise linear behavior of spill with reservoir elevation and target level penalty function. The curves are modeled as ten segment piecewise linear curves. These curves are implemented in the solution using Separable Programming with Special Ordered Sets of Type 2 [3]. Special Ordered Sets of Type 2 have the characteristic that only two adjacent variables in the set may be non-zero and their total is equal to unity.

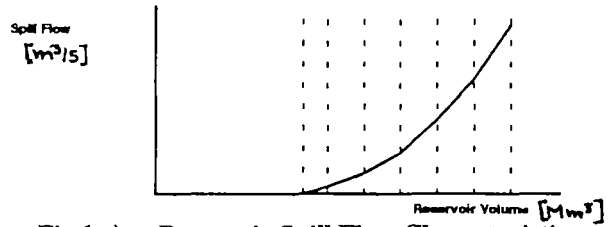

Fig. 1.a) Reservoir Spill Flow Characteristic

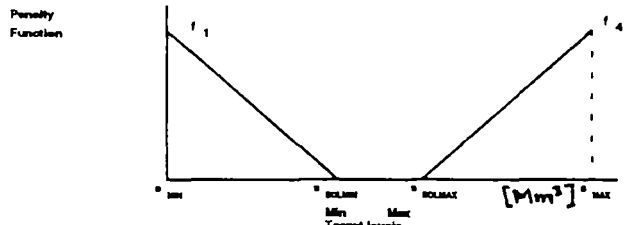

Fig. 1.b) Reservoir Target Level Penalty Function

Tunnel and Canal Models

$$Q_{ij,t} = Q_{0,ij} + \alpha_i s_{i,t} + \alpha_j s_{j,t} \quad (4)$$

Unit Models

The form of the unit input/output characteristic is shown in Figure 2.

This unit characteristic is represented by the following equations based on nominal head conditions from reservoir target levels:

$$q_{n,t} = u_{n,t} Q_{best,n} + Q_{up,n,t} - Q_{dn,n,t} \quad (5)$$

$$P_{n,t} = u_{n,t} P_{best,n} + A_{up,n} Q_{up,n,t} - A_{dn,n} Q_{dn,n,t} \quad (6)$$

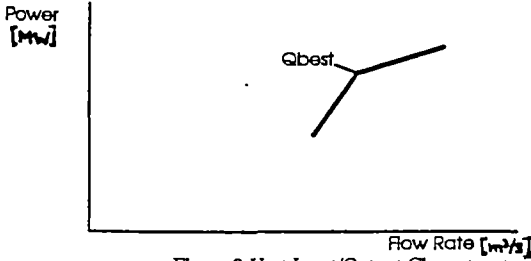

Figure 2 Unit Input/Output Characteristic

There is no need to model the full unit characteristic as almost all units are scheduled to operate at maximum efficiency only.

The Q_{up} and Q_{dn} terms are used to allow operation away from maximum efficiency when it is required to meet a constraint in the hydro system. These terms are given penalties in the objective function so that maximum efficiency operation is produced wherever possible.

Generating Unit Constraints

Additional integer constraints are added to address the requirement that the units operate in contiguous periods of maximum efficiency operation.

The following constraints ensure that the flows through the unit branches are zero when the unit is off-line ($u_{n,t} = 0$) and can be non-zero when the unit is on-line ($u_{n,t} = 1$).

$$q_{n,t} - u_{n,t} Q_{min,n} \geq 0 \quad (7)$$

$$q_{n,t} - u_{n,t} Q_{max,n} \leq 0 \quad (8)$$

$$P_{n,t} - u_{n,t} P_{min,n} \geq 0 \quad (9)$$

$$P_{n,t} - u_{n,t} P_{max,n} \leq 0 \quad (10)$$

The following constraint is used to establish the unit start/stop variables so that the number of start-ups during a 24 hour period may be controlled.

$$u_{n,t} - u_{n,t-1} = y_{n,t} - z_{n,t} \quad (11)$$

The daily water release constraint determines the number of time increments of operation for each unit in the 24 hour period. Mathematically, this constraint can be expressed as:

$$NUP_{min} \leq \sum_t u_{n,t} \leq NUP_{max} \quad (12)$$

where NUP_{min} and NUP_{max} are the minimum and maximum number of time increments of operation respectively.

The number of start-ups in a given period may also be controlled using an additional constraint:

$$\sum_t y_{n,t} \leq NS_{max} \quad (13)$$

where NS_{max} is the maximum number of unit start-ups allowed in the 24 hour period.

Objective Function

The main objective of the optimization is to maximize the electrical energy produced by the released water. This maximization is achieved by ensuring that the contiguous periods of maximum efficiency operation determined by the mid-term storage policy fit under the daily load curve with minimum inefficient operation. The power balance constraint is relaxed by adding a slack variable for the system generation at each time increment and applying a piecewise-linear cost function to this slack generation as shown in Figure 3.

Figure 3 - Cost Function

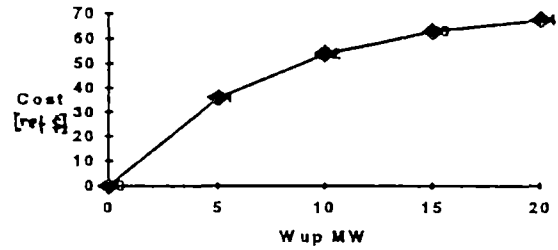

As part of the relaxation of the power balance constraint so that the slack variables may be used to implement the best fit of the operation periods under the daily load curve, an offset W_{FIX} is added so that this constraint becomes:

$$\sum_n P_{n,t} - W_{up,t} = D_t - W_{FIX} \quad (14)$$

where $\max(W_{up,t}) = 2 * W_{FIX}$.

A set of Special Ordered Set variables ($\omega_{i,t}$) are defined to represent the W_{up} variables and the piecewise-linear cost characteristic:

$$W_{up,t} = \omega_{1,t} W_1 + \omega_{2,t} W_2 + \omega_{3,t} W_3 + \omega_{4,t} W_4 \quad (15)$$

$$C_{w,t} = \omega_{1,t} C_1 + \omega_{2,t} C_2 + \omega_{3,t} C_3 + \omega_{4,t} C_4 \quad (16)$$

The integer constraints on the number of start-ups and the number of hours of operation in the 24 hour period ensure that the integer solutions found in the MILP branch and bound process represent contiguous operation periods.

These additional terms in the objective function ensure that the combination of maximum efficiency operation periods selected in the MILP solution will maximize the energy production from the released water and minimize the deviation of the total generation from the total load.

The relaxation of the power balance constraint results in a slight mismatch between total generation scheduled by HSC and the total system load. The HED function adjusts the unit outputs in the real-time to correct this mismatch with minimum loss of efficiency. If this water associated with the mismatch, cannot be held in minor or major storages, or inflow condition changes beyond a user specified threshold, HED triggers the HSC function to produce a new schedule.

The objective function used in the generation scheduling problem then becomes:

$$\begin{aligned} \text{Maximize } \sum_t (C_{w,t} - K_{\text{updn}} \sum_n (Q_{\text{up},n,t} + Q_{\text{dn},n,t}) \\ - K_{\text{targ}} \sum_k (f_k(s_k)) - K_{\text{spill}} \sum_{ij} Q_{ij,t} \\ + \sum_n K_{\text{merit},n,t} q_{n,t}) \end{aligned} \quad (17)$$

where:

K_{updn} = Penalty factor for Q_{up} and Q_{dn}

K_{targ} = Factor for reservoir target penalty functions

K_{spill} = Penalty factor applied to spill flows

$$K_{\text{merit},n,t} = \alpha_{1,n} * (t ** \Delta W_n) \quad (t=1,48) \quad (18)$$

$$\Delta W_n = \alpha_{2,n} * \Delta V_n * (\alpha_{3,n} * q_{n \text{ rel}} - \sum_i \alpha_{3,i} * q_{i \text{ rel}}) \quad (19)$$

where:

i - all upstream stations where tailwater and this reservoir are one

$\alpha_{1,n}, \alpha_{2,n}$ - normalisation - conversion constants

$\alpha_{3,n}$ - conversion constant, function of maximum efficiency and gross head

q_{rel} - defined daily (EA) release for the unit [Mm^3]

ΔV_n - total daily inflow into reservoir on power station with unit n [Mm^3]

The merit factor is a constant applied to the operation of unit n in time increment t . ΔW_n represent the amount of gained/lost energy through increasing the head in the

reservoir by the total daily inflow. This parameter incorporates the increase/decrease of head for all units connected with that reservoir based on the α_3 for each unit.

This composite objective function results in the maximization of the additional generation obtained from taking advantage of the head variation while minimizing the deviation from maximum efficiency and minimizing spill and the deviation from reservoir level targets.

IV. HYDRO ECONOMIC DISPATCH

A. Problem Definition

The real-time Hydro Economic Dispatch function cycles on a 5 minute basis providing base points for use by AGC. HED uses the same hydrological models as used by HSC and executes in a short-term time frame of up to 2-4 hours using a 5 minute time increment[4].

The HED is performed by allocating the desired hydro generation so that the reservoir target elevations obtained from a previously executed study HSC solution are respected. The HED function also ensures that the hydro units are dispatched close to the theoretical maximum efficiency point for the real-time telemetered head level, adjusted every 5 minutes.

During the HED solution, a fixed commitment of the units is assumed. This commitment is obtained from the real-time unit status and the scheduled commitment of the HSC function. A heuristic method, as described in [4], is used to determine the exact 5 minute interval for commitment of those units which are to be placed on-line within the study period.

This approach ensures that the HED economically adjusts the HSC plan, but also foresees well in advance when deviation from the plan cannot be adjusted and triggers a reschedule of HSC. This close coupling of HSC and HED makes the HSC function more flexible and real-time oriented. This is ensured by using the detailed hydro model and the study period for HED execution.

B. Mathematical Formulation

The model curves are constructed on a station basis for a given combination of units on-line. It is assumed that all on-line units within a station will be equally loaded.

For each unit, the set of weighting variables β is defined to represent the break-points on the piecewise linear input/output curves.

$$P_{n,t} = \sum_i \beta_{i,n,t} P_{i,n} \quad (20)$$

$$q_{n,t} = \sum_i \beta_{i,n,t} Q_{i,n} \quad (21)$$

HED Objective Function

The objective of the HED solution is to minimize the deviations of the reservoir levels from their target values provided by the HSC function, minimize energy loss through spill and distribute the offset from maximum efficiency based on the actual curve.

$$\text{Minimize } \sum_t (K_{\text{targ}} \sum_k (f_k(s_{k,t}) + \sum_n (\text{EFACT}_n q_{n,t} + K_{\text{spill}} \sum_{ij} Q_{ij,t})) \quad (22)$$

The K_{targ} and K_{spill} constants are the same as those defined in the earlier section on HSC.

The EFACT_n are calculated as follows:

$$\text{EFACT}_n = \text{EFACTA}_n * \text{EFACTO}_n \quad (23)$$

$$\text{EFACTA}_n = (1 + \varepsilon_n) * (\Delta P / \Delta Q)_{\eta_{\text{max}1,\text{ref}}} / (\Delta P / \Delta Q)_{\eta_{\text{max}1,n}} \quad (24)$$

ε_n = a small number derived from a user defined priority list so that units are dispatched in the order defined in the list

$(\Delta P / \Delta Q)_{\eta_{\text{max}1,\text{ref}}}$ = input/output characteristic slope at maximum efficiency for the reference unit which is normally the first in the priority list.

$(\Delta P / \Delta Q)_{\eta_{\text{max}1,n}}$ = input/output characteristic slope at maximum efficiency for unit n

EFACTO_n = user defined weighting factor to allow manual adjustment of the unit dispatch priorities with default value of one.

V. RESULTS

Figure 4 illustrates a set of results obtained with the program for a 24 hour study period. The mid-term release policy determined the operation periods at maximum efficiency for each plant. The HSC solution determined the manner in which the contiguous operation periods should be arranged in order to minimize inefficient operation and maximize the additional energy obtained by operating run-of-river plant at a higher head level. The Devil's Gate and Cethana plant have the largest head effect. These plants are

scheduled later in the day so that they operate at a higher head level. Base load plants (500MW) are not shown to achieve clarity.

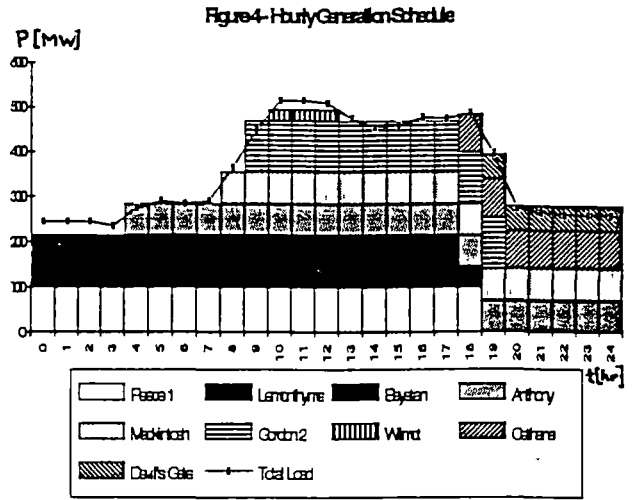

The program has been tested off-line using historical operating plans. The generation schedules produced show a significant improvement in overall efficiency over those produced using current techniques and the time required for an operator to produce a 24 hour schedule has been reduced by six hours.

One major benefit of HSC/HED is obtained by being able to automatically reschedule the plant in response to weather changes, load changes or for equipment outages. There is 30-60% probability that a reschedule will be required on any particular day as a consequence of one of these factors. Using current techniques, it is not possible to reschedule in the time between the occurrence of the event and the start of the new schedule period.

The other area in which energy is saved results from distributing the deviation from maximum efficiency operation across a greater number of units and shows improvement from 0.3 - 0.6% depending on the season.

A conservative estimate is that the savings will be up to six hours daily of an operators time plus 0.5% in annual stored energy savings. There is the possibility for future savings in mid term optimization by decreasing the risk of spill through better control of short term storage levels.

Figure 5 shows an example which illustrates the savings based on distributing the deviation from maximum efficiency operation so the reduction in efficiency required to balance the generation and load is minimized [4].

The dashed line shows the differences between load and the total of the maximum efficiency operation points for all on-line units. In real-time operation, this difference is covered by operating several units at an inefficient output level. The full line shows the MW savings when this offset is covered by more than one unit based on the actual efficiency curve.

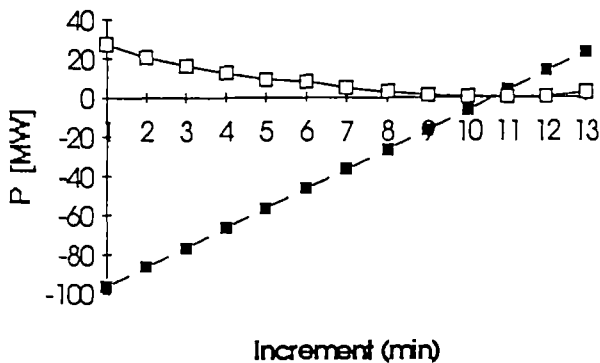

Figure 5 Deviation from Efficient Operation

A comparison with historical generation statistics shows average savings of 0.3-0.4% per year based only on the savings obtained from minimizing the deviation from efficient operation.

A typical seven day schedule is solved in 20 minutes wall clock time and 12 minutes CPU time on an Alpha 2100 machine. A typical 4 hour dispatch is solved in 2 minutes wall clock time for the first solution and three seconds for subsequent solutions.

VI. CONCLUSIONS

This paper presents a concept for real-time hydro scheduling and dispatch which uses a coordinated approach for the half-hourly scheduling and real-time dispatch of hydro plants. A Mixed Integer Linear Programming algorithm coordinated with a rule-based simulation has been successfully implemented in a large scale hydro system.

A commercially available MILP package has been successfully used to solve for the half-hourly generation schedule that maximizes the stored energy. The stored energy savings provide some buffer for dry seasons and are also available for possible future export.

This schedule is further refined in the real-time time frame using a Linear Programming solution to minimize the units' deviation from maximum efficiency operation and the

storage levels' deviation from the targets set by the HSC solution.

The authors believe that this approach can be useful in any independent predominantly hydro electric utilities to achieve both economic benefits and better water utilisation and control, especially in the open electricity market arrangement.

VII. REFERENCES

1. W.W-G.Yeh, "Reservoir Management and Operations Models: A State-of-the-Art", WRR Vol. 21, No. 12, Pages 1797-1818, December 1985
2. M.R.Piekutowski, T.Litwinowicz, R.J.Frowd, "Optimal Short-Term Scheduling for a Large-Scale Cascaded Hydro System", IEEE Transactions on Power Systems, Vol. 9, No. 2, May 1994, pp 805-811.
3. H.P. Williams, "Model Building in Mathematical Programming", Wiley, 1990.
4. N.Tufegdzcic, P.Hyslop, W.Stadlin, "A Unique Concept for Hydro Economic Dispatch", Proceedings of the 1993 ISEDEM symposium on Electricity Distribution and Energy Management, Singapore

Nenad Tufegdzcic received the B.Sc. and M.Sc. degrees in Electrical Engineering from the University of Belgrade in 1987 and 1991 respectively. He joined the Hydro Electric Commission of Tasmania in 1992 where he has been involved with the specification and implementation of their new Energy Management System. His main research interests are in the area of the development and implementation of dispatch and scheduling applications for the Energy Management System.

Roderick J. Frowd (M'77) received his B.E. degree in Electrical Engineering from the University of Queensland in 1976 and his M.E. degree from the University of Florida in 1980. He has worked for several EMS vendors, and EMS consulting company and for Queensland Electricity Commission. He is currently an independent consultant in the advanced network analysis and generation scheduling areas. His specialty is currently applying modern optimization methods to power system scheduling problems.

Walter O. Stadlin (M'53, SM'71, F'82) holds B.S. and M.Sc. degrees in electrical engineering from the New Jersey Institute of Technology and the University of Pennsylvania respectively. Since 1983 he has held the position of Principal Engineer at Macro Corporation where he has consulted on numerous hydro and thermal electric utility projects. As principal scientist at Leeds and Northrup Company he received patents in the field. He is a member of the Power System Engineering Committee and a registered professional engineer in Pennsylvania and California.

AN OPTIMAL REAL-TIME SHORT TERM OPERATION OF INDEPENDENT HYDRO GENERATOR COMPANY IN THE OPEN ELECTRICITY MARKET

Nenad Tufegdžic

Hydro Electric Commission
Hobart, Australia

Paul Hyslop

Hydro Electric Commission
Hobart, Australia

Abstract The paper describes an approach to short-term hydro scheduling and dispatch for the independent hydro generator in the Open Electricity Market(OEM) environment. The paper discusses optimal operation of hydro electric power plants and possible control arrangements in the OEM environment. The algorithm currently used by the Hydro Electric Commission, which operates as an isolated purely hydro system, has been modified to suit any independent hydro generation company. It also provides a different perspective for operation of hydro power plants as part of a hydrothermal system and can also be used for hydro optimisation in hydrothermal systems. The algorithm uses a detailed model of the interconnected hydro system to determine the half-hourly operating schedule based on allocated water releases with the objective of maximising overall return from the market. The plan is revised and updated every five minutes as actual generation requirements and inflows change. This ensures continuous real-time optimisation which is necessary for continuously changing spot prices and inflows into reservoirs. The concept is developed for a decentralised market (as in Australia), but the concept can be used in a centralised dispatched market or centrally planned systems for the optimisation of hydro resources.

Keywords: optimisation, national market, hydro generator

I. INTRODUCTION

Power system operation in many countries is moving towards an OEM environment. As a consequence changes in the scheduling and dispatch of generation are visible. The trend in operation and control in the competitive environment is towards decentralisation, especially in big systems. National grid control centers (NGCC) have a limited coordination role with greater focus on the facilitation of energy trading. This will mean that individual generator companies will need to develop their own centralised control and market trading centers (CMTC). The CMTC will have the role of scheduling and controlling all company generators in order to maximise the return to stakeholders in a dynamic market environment. A similar type of center already exists for most coupled hydro power plants where multiple cascades require continuous control and coordination.

In the OEM environment hydro power plants will be operated in the manner similar to that in a pure hydro system. System inflow prediction, which is the fuel resource for hydro will be the same. The hydro company will participate in the market as a single virtual unit. The hydro generator will bid for a share of energy plus regulation in each trading interval (typically five minutes) and will receive a dispatch setpoint and regulation participation factors following clearing of the market. The only connection (from dispatch point of view) with the rest of the system will be through the market spot price and the share of generation allocated to the virtual hydro unit. The hydro companies will optimise production by manipulating individual station outputs to meet the virtual unit's required base point. The NGCC dispatch base point is equivalent to load changes in an isolated system with the only difference being that the dispatch point will depend on the market environment instead of actual customer loads.

The daily hydro scheduling process commences with an assessment of the mid-term operating policy to determine the amount of water to be released from storages based on the forecast market price during the next trading day. This allocation of available energy is performed using a set of rules to transfer mid-term planning objectives and market forecasts into short-term scheduling constraints, while also taking into account inflow prediction. This mid-term operating policy is a combination of stochastic inflow forecasts, maintenance planning and modelling of economic factors for the future market.

The result of this daily energy allocation process is a set of daily water releases for each cascade. They will depend on the actual reservoir levels, inflow forecast, short and medium term market forecasts and the portfolio of contracts that the company has committed to. The Unit Commitment and Scheduling (UCS) function is then used to optimally schedule these units to maximise overall return using the available water.

To achieve this objective, the traditional power balance constraint has been relaxed and the objective function set to reflect expected prices for each trading interval throughout the day. Unit models have been developed with the assumption that each unit is operated at its maximum efficiency point wherever possible so that maximum energy is obtained from the released water. Deviation is allowed if the forecast price for an interval will improve return. Head efficiency and start up costs are taken into account. During this scheduling process, a detailed model of the reservoirs and flow paths which comprise the hydro system is used so that the effects of the unit schedules on the reservoir levels, spill flows and other flows in the hydro system are fully modelled[1].

The half-hourly unit commitment schedule produced by the UCS function is implemented in real-time using the Dynamic Hydro Economic Dispatch (DHED) function. The DHED is performed using a detailed model of the hydro system so that all reservoir and flow constraints are respected during dispatch. This function also provides a look-ahead capability by performing a dispatch solution for up to 4 hours ahead using a 5 minute time increment. This ensures that economic adjustment of the UCS operating plan occurs in a smooth manner while still maintaining the UCS objectives. It includes the added capability to commit/decommit units down to a resolution of five minutes. DHED also ensures that contractual requirements for regulating reserve and other ancillary services is optimally allocated across the units. The close coupling between UCS

and DHED including feedback for rescheduling makes the overall optimisation concept more dynamic and real-time orientated.

The most important achievement using this approach is its flexibility for rescheduling and the dispatch look ahead function; an important component, because of uncertainty in the various forecasts.

II. NEW CONTROL HIERARCHY - GENERAL

In the electricity market environment the generation market participant which owns more than one generator needs to develop a CMTTC. This center may be treated as single virtual generator by the NGCC. The advantages of forming the CMTTC are the following:

- Greater flexibility in bidding
- Reduction of the risk to high spot price exposure, caused by generator trips or unavailability
- Opportunity to optimise operation between company generators
- Ability to control coupled hydro plants in cascade
- Greater flexibility and improved efficiency in providing regulating reserve and other ancillary services.

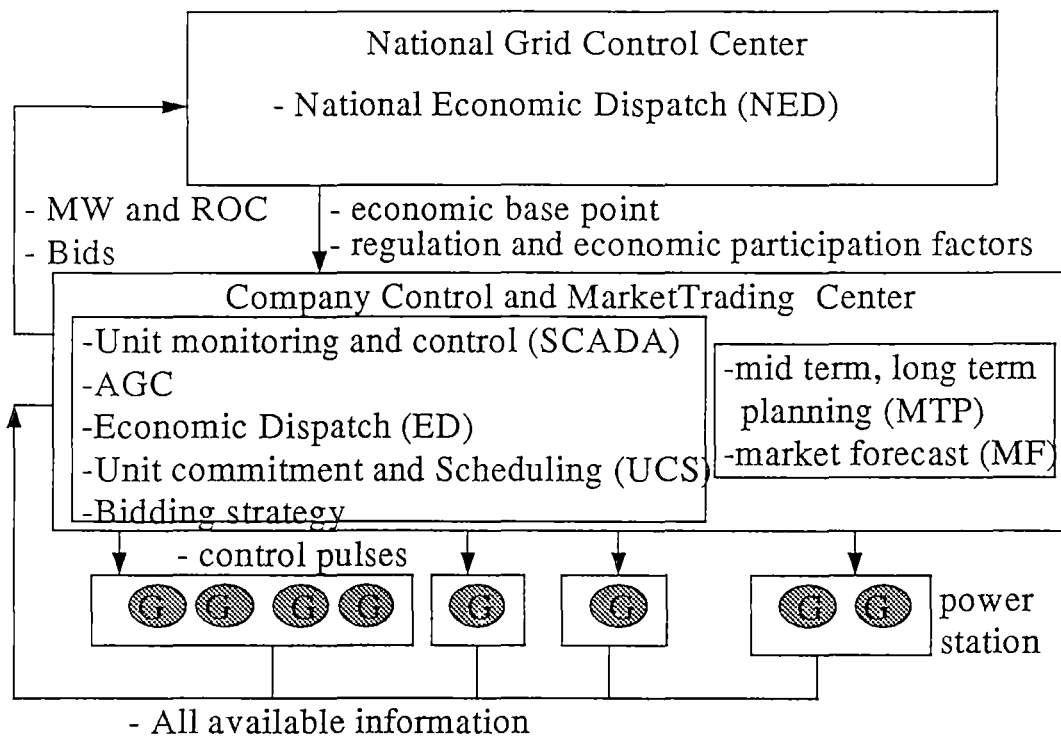

Figure 1: Control structure for the generator owner company

Today most of the above functions are performed by the coordinating control centers. Regional or station control centers perform only local monitoring and control. With the new NGCC taking the role of dispatching the units on the basis of bids without considering unit commitment, start up/shut down and water

coordination, new control centers will need to consider in detail operation of generators. A possible new control structure for all generator companies as market participants is shown on figure 1.

The CMTC software will be an independent Energy Management System developed to include the market trading function and networked with the NGCC. The CMTC will provide bids into the market based on strategies determined through the CMTC system. The NGCC will provide virtual unit base point, regulating and economic participation factors to the CMTC system. The virtual unit base point will be treated as the load requirement in CMTC's economic dispatch (ED)(DHED for hydro) and regulation and economic participation factors will be reallocated to each unit to satisfy the requested MW range and rate of change (ROC). Other information associated with system security and the commercial obligations of participants will also be enclosed.

New features will need to be included in the standard EMS like :

- midterm planning forecasts (MTP) (including maintenance planning)
- Market forecast (MF) (short and medium term)

(These two functions are not discussed here as they do not present direct real time control software).

As the cost for new CMTC may be significant an innovative approach to the organisation of the CMTC may be required. One possibility is for the generating company to use a common independent system operation agent equipped with a SCADA/AGC system and additional applications (ED, UCS, MTP and MF). A second option is to purchase/develop their own EMS and market trading system.

III. FUNCTIONAL HIERARCHY FOR UCS AND ED SOFTWARE

The functional hierarchy of the UCS and the DHED is illustrated in Figure 2. The Energy Allocation (EA) function executes on a daily basis every half hour for the current trading day and for up to seven future days. The Generation Scheduling /Rescheduling (GSR) function executes every half hour for the current trading day and for up to seven future days.

The DHED function economically distributes the unit dispatch points based on telemetered real-time data and NGCC dispatched base point for the virtual unit during the current trading day.

DHED looks ahead for a period of up to 4 hours so that the plant may be scheduled to smoothly follow the reservoir target levels set by the UCS function and to meet the NGCC dispatched virtual unit base point.

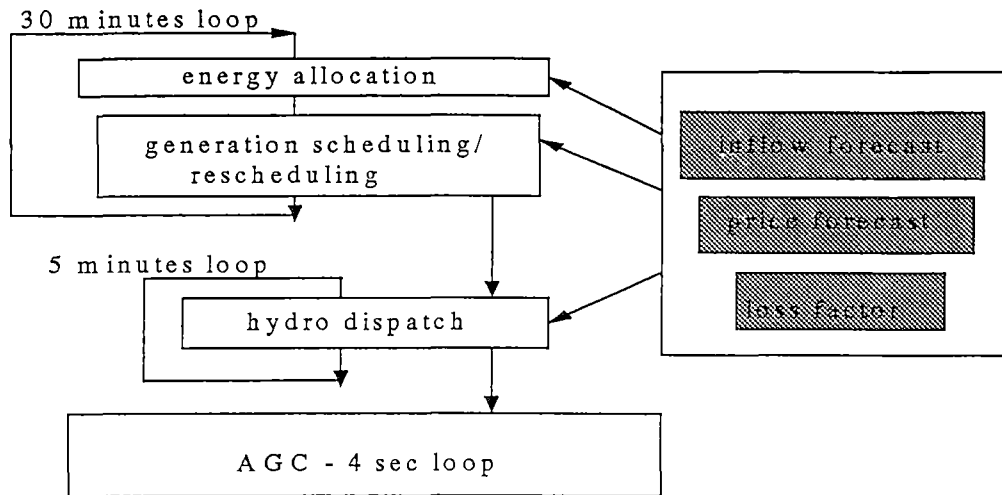

Figure 2 UCS/ED Hierarchy

IV. ALGORITHM

The full model and set of equations has been explained in reference [1]. The objective function and benefits of economic dispatch are discussed here as they are the only significant changes to the existing algorithm.

Objective Function

The main objective of the optimisation is to maximise the overall return during whole trading day from electrical energy produced from available water, as determined from mid-term planning.

The major innovation in reference [1] is the relaxation of traditional power balance constraint and its incorporation into the objective function. This assumption is now more visible because the dispatched base point (load) will vary during the day based on the market price. The power balance constraint will now be presented as two constraints:

$$P_{\min,t} < \sum_n P_{n,t} = < P_{\max,t}$$

where $P_{\min,t}$ and $P_{\max,t}$ represents minimum and maximum capacity of virtual unit for that time period. Maximum will be the sum of maximum output for all units planned for commitment. Minimum unit output will be defined to avoid spilling or by any other constraint (irrigation, minimum power output, minimum release, etc.).

The return based on the market price will be the most important part of the objective function and will be defined as:

$$C_{w,t} = \omega_{1,t} * P_{n,t}$$

where $\omega_{1,t}$ presents expected price for period t.

Further enhancement (not discussed in the paper) can be achieved by combination of probable price scenarios and incorporation of stochastic price prediction into objective function.

The objective function used in the generation scheduling problem then becomes:

$$\begin{aligned} \text{Maximise } \sum_t (C_{w,t} - \sum_n (Q_{up,n,t} + Q_{dn,n,t}) \\ - K_{targ} \sum_k (f_k(s_k)) - K_{spill} \sum_{ij} Q_{ij,t} \\ + \sum_n K_{ment,n,t} q_{n,t}) - \sum_t \sum_n y_{n,t} * C_{w,t} * Q_{n,loss} \end{aligned}$$

where:

$$Q_{up,n,t} = K_{up,n,1} * Q_{up,n,1} + K_{up,n,2} * Q_{up,n,2} +$$

$$K_{up,n,3} * Q_{up,n,3}$$

$$Q_{dn,n,t} = K_{dn,n,1} * Q_{dn,n,1} + K_{dn,n,2} * Q_{dn,n,2} +$$

$$K_{dn,n,3} * Q_{dn,n,3}$$

represent the linearised P/Q curve variation both side of the maximum efficiency point presented through the special order set variables.

$y_{n,t}$ - start up integer variable for unit n interval t

$u_{n,t}$ - unit status integer variable for unit n interval t

with the constraints:

$$2 * y_{n,t} + u_{n,t-1} + u_{n,t} \leq 3$$

$$y_{n,t} - u_{n,t} \leq 0$$

$$u_{n,t} - u_{n,t-1} - y_{n,t} \leq 0$$

$Q_{n,loss}$ - constant which represent losses incurred by start up[4]

K_{targ} - Factor for reservoir target penalty functions

K_{spill} = Penalty factor applied to spill flows

$K_{merit,n,t} = \alpha_{1,n} * (t ** \Delta W_n)$ (t=1,48)

$\Delta W_n = \alpha_{2,n} * \Delta V_n * (\alpha_{3,n} * q_{n rel} - \sum_1 \alpha_{3,i} * q_{i rel})$

where:

i - all upstream stations where tailwater and this reservoir are one

$\alpha_{1,n}, \alpha_{2,n}$ - normalisation - conversion constants

$\alpha_{3,n}$ - conversion constant, function of maximum efficiency and gross head

q_{rel} - defined daily (EA) release for the unit

ΔV_n - total daily inflow into reservoir on power station with unit n

The merit factor is a constant applied to the operation of unit n in time increment t. ΔW_n represent the amount of gained/lost energy through increasing the head in the reservoir by the total daily inflow. This parameter incorporates the increase/decrease of head for all units connected with that reservoir based on the α_3 for each unit.

This composite objective function results in the maximisation of the net profit while taking into consideration the advantages of improved head variation, minimising the deviation from maximum efficiency, minimising spill and minimising deviation from the mid term operating plan designed target levels.

One of the outputs of the UCS is the bidding strategy based on optimised schedule and unit commitment, existing long and short term bilateral contracts *and risk management decisions*. The simplest bidding strategy, which can be interpreted from GSR, is presented in Table 1.

Bands IV and V can be broken up based on the committed plants maximum efficiency points.

band	MW amount	price
I	spill	0
II	will spill tomorrow	forecast tomorr. price
III	contracts - (I+II) (if >=0)	contract price + operation cost
IV	Calculated sched. -(sum (I,II,III))	exp. price*Loss Factor
V and up	additional long term release	future value of water and premium to cover risk of long term failure

Table 1: Bidding strategy

The advantage of this program is that it will optimise the operation through using the least expensive water and through rescheduling which will ensure optimal adjustments as deviations from forecast inflow and demand (price) occur.

Economic Dispatch

The real-time Dynamic Hydro Economic Dispatch function cycles on a 5 minute basis providing base points for use by AGC. DHED uses the same hydrological models as used by HSC and executes in a short-term time frame of up to 4 hours using a 5 minute time increment. The detailed model is explained in reference [1,3].

The major benefits from DHED are

- Coordination of releases from coupled cascade hydro plants, based on real-time telemetered data
- Optimal distribution of generation according to satisfy the virtual unit base point set by NGCC
- Provides flexibility and economic improvement for provision of ancillary services reserve

V. RESULTS

Results are discussed for three major areas of benefit. Coordination of coupled hydro plants is necessary and obvious and so this aspect is not discussed.

The first benefit is optimal utilisation of water. Typical gross head efficiency curves versus discharge are shown in figure 3.

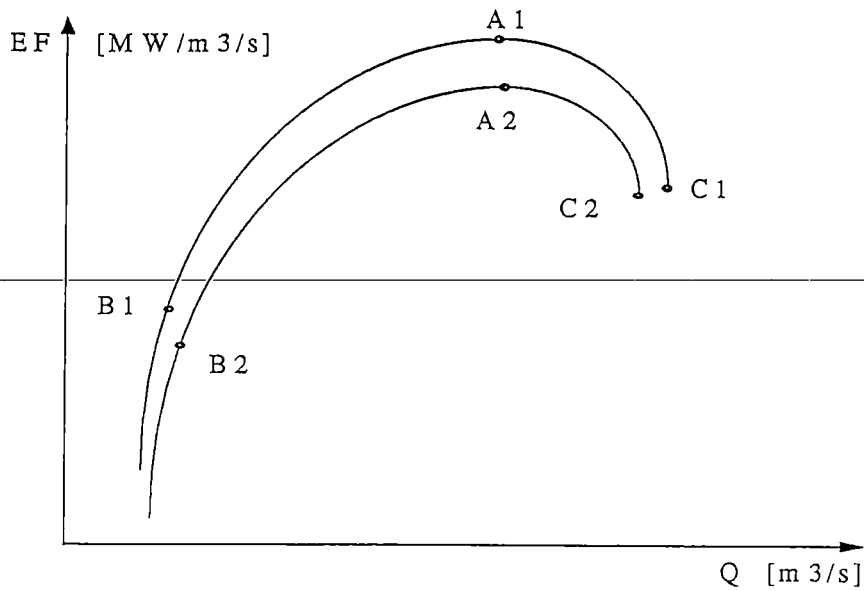

Figure 3: Efficiency vs discharge curves

If only the price element of objective function is used the machine will be scheduled to operate in the highest price intervals on the full gate point (point C). By operating at point A, however, more energy can be produced from the same amount of water. The following equations calculate allowed decrease in price (Δ) which will satisfy the condition that operating at maximum efficiency is more profitable than operating during the maximum price period.

$$t_2 * P_2 * A - t_2 * P_1 * A - t_2 * P_1 * (Q_2 / Q_1 - 1)(A - \Delta) \geq 0$$

$$\Delta \geq t_2 * A * B$$

$$B = (Q_2 * (EF_1 - EF_2)) / (EF_1 * (Q_2 - Q_1))$$

where

A - price during high price period

t_2 - period of operation in the high price region

$t_2 * Q_2$ - available amount of water

$$P_2 = Q_2 * EF_2$$

Typical values for B are between 0.1 and 0.3 depending on machine types, number of units and head variation during the day. This means that operation of a unit on full gate for two hours during the peak price period may not be the optimal solution. Calculations show that it is better to operate a unit on maximum efficiency for the peak period and an additional period (using the same total amount of water), if the spot price for the additional period is greater than 60% of the peak price. This is a simple example and in the real

world units do not need to operate only at these two points. Figure 4 shows an example of unit operation with different objective functions.

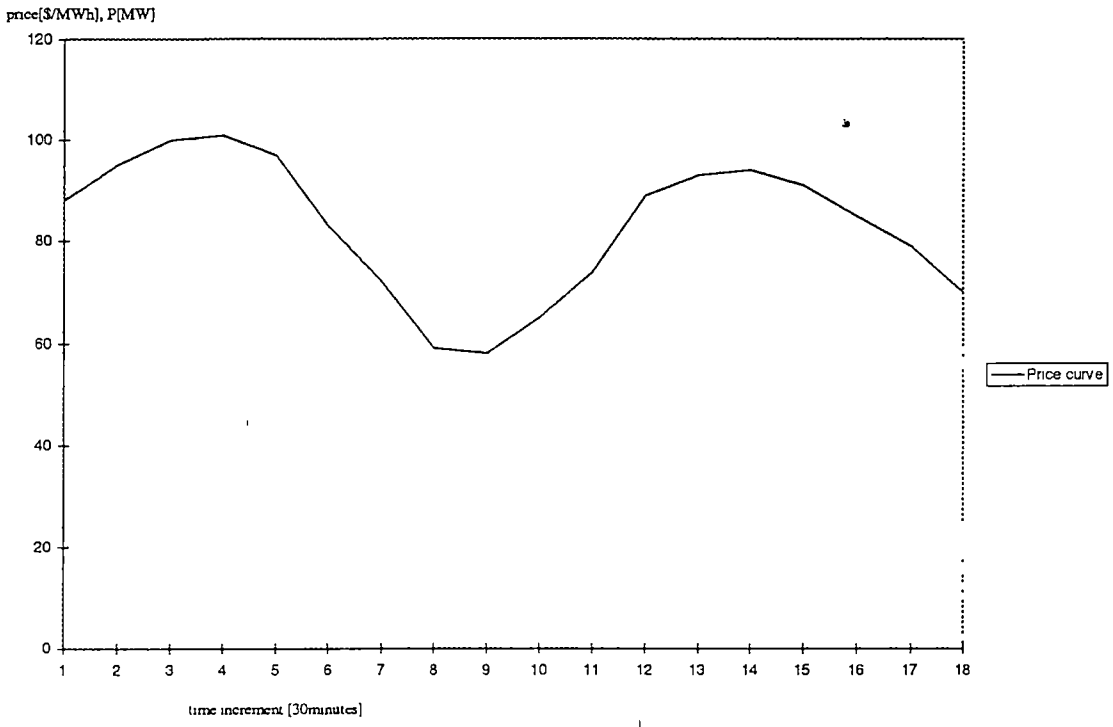

Figure 4a). Price

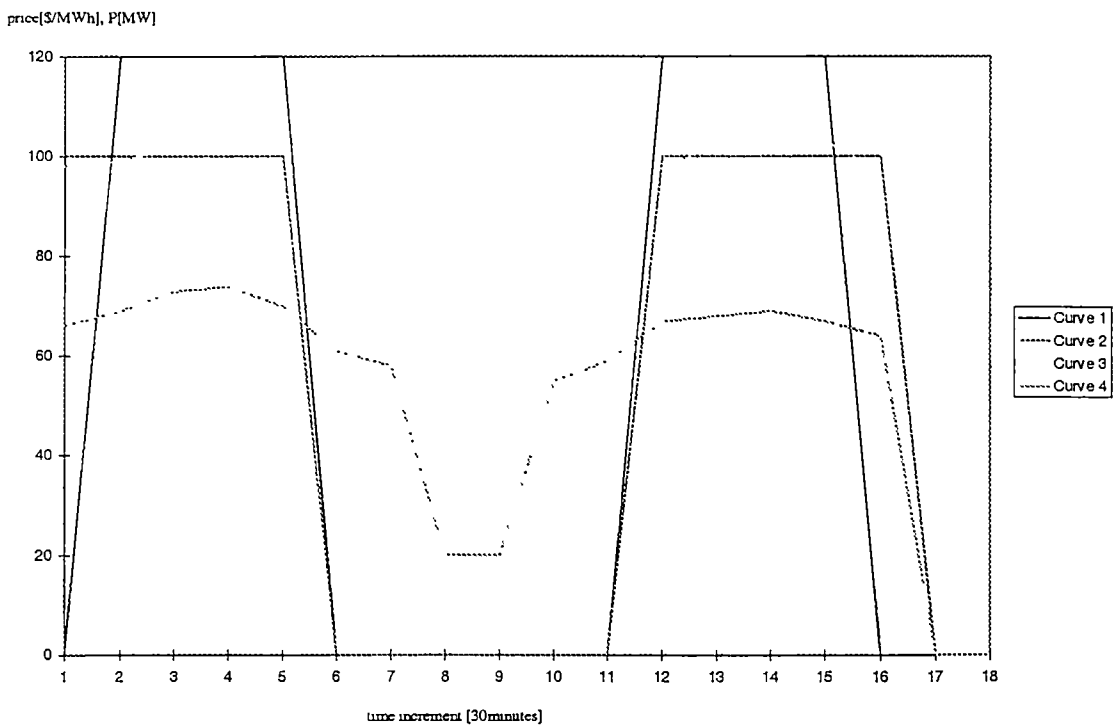

Figure 4b): Different operation for different objective function

Table 2 shows that using an objective function based on price only will not provide the maximum return. It also shows that the full model gives better results than the partial model based on maximum efficiency/full

gate operation. Start up costs, representing real costs, need to be included and may significantly influence the generators operation.

curve number	objective function used	objective function value
1 - unit MW	price	90720
2 - unit MW	price, effic. (0,1)	92900
3 - unit MW	price, efficiency	93023
4 - unit MW	price,efficiency, startup cost(10000)	83396

Table 2: Objective function comparison

The second is that the objective of operating on maximum efficiency puts the hydro generator in a better position to provide reserve as an ancillary service. Figure 5 shows an example which illustrates the savings that occur based on distributing the reserve to minimise deviation from maximum efficiency operation so that the reduction in overall efficiency required to balance the generation and load is minimised [1,3] when operating as virtual unit.

The area resents the national market instantaneous reserve requirement. The bars show the MW savings available when this reserve requirement is covered by multiple units based on actual efficiency curves.

P[MW]

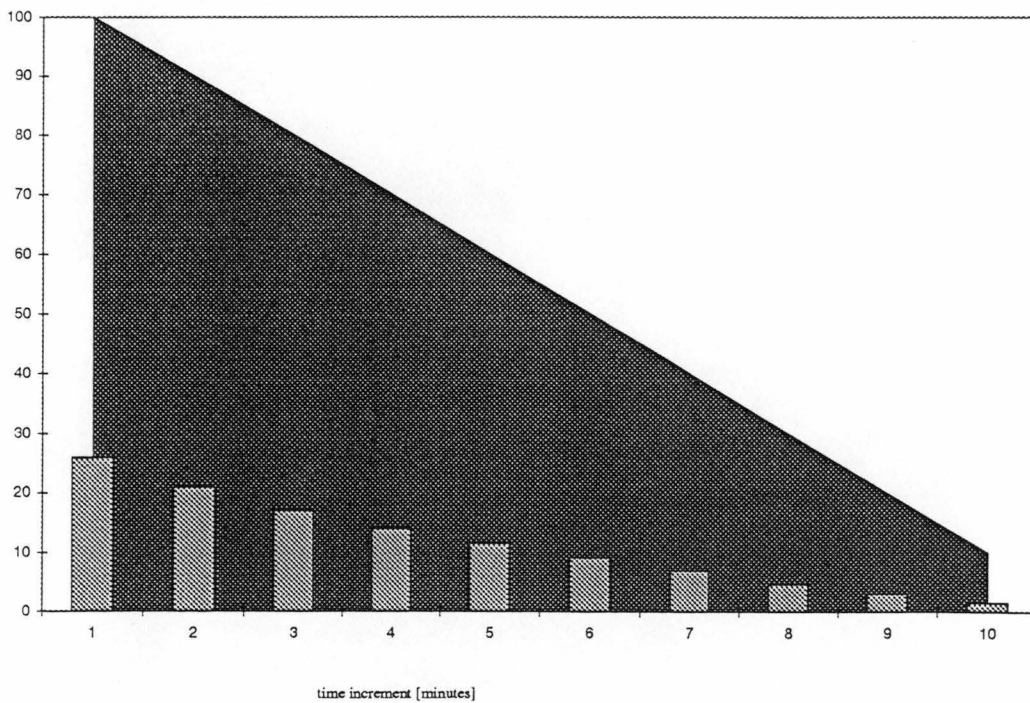

Figure 5: Deviation from efficient operation

A comparison with historical generation statistics shows average savings of 0.3-0.4% per year based only on the savings obtained from minimising the deviation from efficient operation.

Curves 1 and 2 on figure 6 shows the operation of two hydro units bid independently - the first unit on the energy market and second as an ancillary reserve during the high spot price period. Curves 3 and 4 show the operation of the same two units bid as one virtual generator. In this case savings are substantial because both generators operate away from maximum efficiency in first case and more efficiently in the second case.

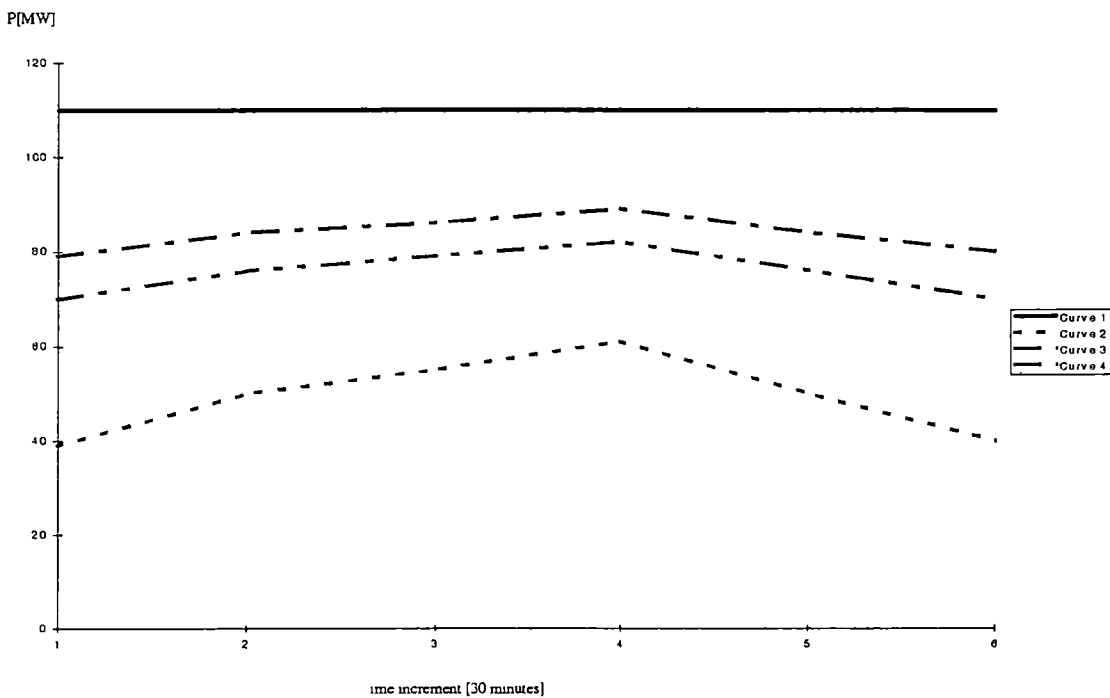

Figure 6: Two unit operation

The previous example also shows that greater bidding strategy flexibility can be achieved, because a single strategy is used based on the available amount of water and then the generators operation is optimised. Otherwise each generator will be bid separately and the strategy will be very complicated because it has to optimise strategies for each generator based on the forecast price. In the first case, if the actual price is lower/higher we reschedule generation and the strategy stays the same. In the second case generator cannot be rescheduled (leading to non-optimal returns) except in continuous auction market environment. In continuous auction market environment above algorithm has the advantage of handling unit commitment and decommitment in a continuous rescheduling environment and can handle all operational system constraints.

This algorithm is specially designed to cope with uncertainty in inflow and load forecast. The rescheduling and DHED look ahead features make whole the operation and market trading system more dynamic and real-time oriented. As the price forecast can be more unpredictable than load forecast, real-time aspects of this package will be more important than in an isolated pure hydro system. It is extremely important in the case when a generator is the price setting generator which means that the full band bid will not be dispatched.

	unit 1	unit 2	virt. unit	unit1 exp	unit2 exp	unit1 act.	un2 act.
full gate	120	110	230				
max eff	85	80	165				
band 1	30	30	80				
band 2	85	80	165				
band 3	120	110	230				
case1				85	80	45	30
case2				85	80	0	75

Table 3: Operation comparison

This example in Table 3 shows that generators do not need to be started up if the price is unexpectedly decreased, and also choice existing for which generator based on long term water strategy is better to use and continue to operate optimally independent of changes in the market environment.

VI. CONCLUSIONS

This paper discuss possible control arrangements and optimal operation of the independent hydro generator company in the OEM environment. The Hydro Electric Commission's EMS software for optimal scheduling and dispatching plants is used to demonstrate the benefits possible in the market environment.

The necessity for second level control centers for hydro generator is shown, with possible benefits for mixed hydro-thermal and thermal generator owners.

The complex objective function which takes into account both market price and technical operation of the system is developed to maximise the return with model flexibility to introduce any other constraint.

The major achievement of this approach is the proposal of the real-time optimisation and scheduling software with rescheduling and look ahead economic dispatch features which ensures continuous optimisation in the uncertain price and inflow environment.

The authors believe that this approach can be useful in any independent predominantly hydro electric utilities to achieve both improved economic returns and better water utilisation and control, especially in the open electricity market arrangement.

VII. REFERENCES

1. N.Tufegdzic, R.J.Frowd, W.Stadlin, "A Coordinated Approach for Real-Time Short-Term Hydro Scheduling", 96 WM 169-3 PWRs, IEEE Winter Meeting, 1996, Baltimore

2. M.R.Piekutowski, T.Litwinowicz, R.J.Frowd, "Optimal Short-Term Scheduling for a Large-Scale Cascaded Hydro System", IEEE Transactions on Power Systems, Vol. 9, No. 2, May 1994, pp 805-811.
3. N.Tufegdzcic, P.Hyslop, W.Stadlin, "A Unique Concept for Hydro Economic Dispatch", Proceedings of the 1993 ISEDEM symposium on Electricity Distribution and Energy Management, Singapore
4. O.Nilsson, D.Sjelvgren "Hydro Unit Start-up Costs and Their Impact on the Short Term Scheduling Strategies of Swedish Power Producers", 96 WM 167-7 PWRS, IEEE Winter Meeting, 1996, Baltimore

References

1. S.Yakowitz, "Dynamic Programming Applications in Water Resources", Water Resources Research Vol. 18, No. 4, Pages 673-696, August 1982
2. W.W-G.Yeh, "Reservoir Management and Operations Models: A State-of-the-Art", Water Resources Research Vol. 21, No. 12, Pages 1797-1818, December 1985
3. A.I.Cohen, V.R.Sherkat, "Optimisation-Based Methods for Operations Scheduling", Proceedings of IEEE, Vol. 75, No. 12, December 1987, pp. 1574-1591
4. B.H.Chowdhury, S.Rahman, "A Review of Recent Advances in Economic Dispatch ", IEEE Transactions on Power Systems, Vol. 5, No. 4, November 1990, pp 1248-1259.
5. S-C.Chang, C-H.Chen, I-K.Fong, P.B.Luh, "Hydroelectric Generation Scheduling with an Effective Differential Dynamic Programming Algorithm", IEEE Transactions on Power Systems, Vol. 5, No. 3, August 1990, pp 737-743.

6. D.Lidgate, B.H.Amir, "Optimal Operational Planning for a Hydro-electric Generation System", IEE Proceedings, Vol. 135, No. 3, May 1988, pp 169-181.
7. R.A.Duncan, G.E.Seymore, D.L.Streiffert, D.J.Engberg, "Optimal Hydrothermal Coordination for Multiple Reservoir River Systems", IEEE Transactions on Power Apparatus and Systems, Vol. PAS-104, No. 5, May 1985, pp 1154-1159.
8. H.Brannlund, J.A.Bubenko, D.Sjelvgrén, N.Andersson, "Optimal Short Term Operation Planning of a Large Hydrothermal Power System Based on a Nonlinear Network Flow Concept", IEEE Transactions on Power Systems, Vol. 1, No. 4, November 1986, pp 75-81.
9. A.Johannesen, A.Gjelsvik, O.B.Fosso, N.Flatabo, "Optimal Short Term Scheduling Including Security Constraints ", IEEE Transactions on Power Systems, Vol. 6, No. 2, May 1991, pp 576-583.
10. P.E.C.Franco, M.F.Carvalho, S.Soares, "A Network Flow Model for Short-Term Hydro-Dominated Hydrothermal Scheduling Problems", IEEE Transactions on Power Systems, Vol. 9, No. 2, May 1994, pp 1016-1022.
11. H.Habibollahzadeh, D.Frances, U.Sui, "A New Generation Scheduling Program at Ontario Hydro", IEEE Transactions on Power Systems, Vol. 5, No. 1, February 1990, pp 65-73.
12. E.B.Hreinsson, "Optimal Short Term Operation of a Purely Hydroelectric System", IEEE Transactions on Power Systems, Vol. 3, No. 3, August 1988, pp 1072-1077.

13. M.R.Piekutowski, T.Litwinowicz, R.J.Frowd, "Optimal Short-Term Scheduling for a Large-Scale Cascaded Hydro System", IEEE Transactions on Power Systems, Vol. 9, No. 2, May 1994, pp 805-811.
14. O.Nilsson, D.Sjelvgrén, "Hydro Unit Start-up Costs and Their Impact on the Short Term Scheduling Strategies of Swedish Power Producers", IEEE 96 WM 167-7 PWRs, Baltimore, USA.
15. R-H.Liang, Y-Y.Hsu, "Hydroelectric Generation Scheduling Using Self-Organizing Feature Maps ", EPSR 30 , 1994, pp 1-8.
16. K.H.Zadeh, R.C.Meyer, J.H.Villada Z., A.Weibull, "Operation Planning and Control of Cascaded Hydro Plants", IEEE Transactions on Power Systems, Vol. 6, No. 2, May 1991, pp 835-841.
17. S.Vemuri, W.J.Hobbs, L.Lemonidis, "Hydro Coordination in an Energy Management System", IFAC Proceedings, March 1992, Munich, Germany.
18. D.W.Ross, S.Kim, "Dynamic Economic Dispatch of Generation ", IEEE Transactions on Power Apparatus and Systems, Vol. PAS-99, No. 6, November/December 1980, pp 2060-2068.
19. N.Tufegdžić, P.Hyslop, W.Stadlin, "A Unique Concept for Hydro Economic Dispatch", Proceedings of the 1993 ISEDEM symposium on Electricity Distribution and Energy Management, Singapore, 1993
20. N.Tufegdžić, R.J.Frowd, W.O.Stadlin, "A Coordinated Approach for Real-Time Short-Term Hydro Scheduling", IEEE 96 WM 169-3 PWRs, Baltimore, USA

21. N.Tufegdzcic "Deterministic Model for Optimal Daily Operation of Cascade Hydro Plants", Master Thesis, University of Belgrade, Belgrade, Yugoslavia, 1991.
22. G.B.Sheble, G.N.Fahd, "Unit Commitment Literature Synopsis", IEEE Transactions on Power Systems, Vol. 9, No. 1, February 1994, pp 128-135.
23. M.E.El-Hawary and G.S.Christensen, "Optimal Economic Operation of Electrical Power Systems", Academic Press, NY, 1979.
24. H.P. Williams, "Model Building in Mathematical Programming", Wiley, 1990.
25. N.Tufegdzcic, P.Hyslop, "An Optimal Real-Time Short Term Operation of Independent Hydro Generator Company in the Open Electricity Market", accepted for publishing in Electric Power Systems Research, 1996
26. CPLEX Optimisation Inc, " Using the CPLEX Callable Library and CPLEX Mixed Integer Library", Cplex Optimisation, 1983
27. R.L.Adams, "Economic Storage Control for Electricity Supply in Tasmania", Journal of Electrical and Electronics Engineering, Vol. 2, No. 3, Australia, September 1982
28. U.G.Knight, "Power systems Engineering and Mathematics", Pergamon Press, NY, 1972

29. I.J.Perez-Arriaga, H.Rudnick and W.O.Stadlin, "International Power System Transmission Open Access Experience", IEEE Transaction on Power Systems, Vol. 10, No. 1, February 1995, pp. 554-564
30. S.Li, S.M.Shahidehpour and C.Wang, "Promoting the Application of Expert Systems in Short-Term Unit Commitment", IEEE Transaction on Power Systems, Vol. 8, No. 1, February 1993, pp. 286-292

Bibliography

A.J.Wood and B.F.Wollenberg, "Power Generation, Operation and Control", John Wiley and Sons, New York, 1984

B.M.Weedy, "Electric Power Systems", John Wiley and Sons, New York, 1967

William D.Stevenson, "Elements of Power System Analysis", McGraw-Hill, 1982

G.L.Nemhauser and L.A.Wolsey, "Integer and Combinatorial Optimisation", John Wiley and Sons, New York, 1988

Lj.Krsmanovic, "Optimal operation of electric power systems", Gradevinska knjiga, Belgrade, 1986

B.Djordevic, "Water usage", Privredno finansijski vodici, Belgrade, 1981

R.Bellman, "Dynamic Programming", Princeton University Press, Princeton, NJ, 1957

R.Bellman, "Applied Dynamic Programming", Princeton University Press, Princeton, NJ, 1957

G.T.Heydt, "Computer Analysis Methods for Power Systems", Macmillan Publishing, 1986

J.Dinkel, G.Kochenberg and D.Plane, "Management Science - text and applications", Richard D.Irwin INC, 1978

A.Johannesen and H.H.Faanes, "Economic Scheduling of a Hydroelectric System", CIGRE, 1968 Session, Report 32-07

R.E.Larson and A.J.Korsak, "A Dynamic Programming Successive Approximations Technique with Convergence Proofs, I and II", Automatica, Vol. 6, pp.245-260, 1970

M.Heidari, V.T.Chow, P.V.Kokotovic and D.D.Meredith,"Discrete Differential Dynamic Programming Approach to Water Resources System Optimisation", Water Resources Research, Vol. 7, No. 2, pp.273-283, 1971

C.R.Gagnon, R.H.Hicks, S.L.S.Jacoby and J.S.Kowalik, "A Nonlinear Programming Approach to a Very Large Hydroelectric System Optimisation", Mathematical Programming, Vol. 6, pp.28-41, 1974

P.A.Mawer and D.Thorn, "Improved Dynamic Programming Procedures and Their Application to Water Resources Systems", Water Resources Research, Vol. 10, No. 2, pp.183-190, 1974

H.R.Howson and N.G.F.Sancho, "A New Algorithm for the Solution of Multi-State Dynamic Programming Problems", Mathematical Programming, Vol. 8, pp. 104-116, 1975

J.L.Cohon and D.H.Marks, "A Review and Evaluation of Multiobjective Programming Techniques", Water Resources Research, Vol. 11, No. 2, pp.202-220, 1975

V.T.Chow, D.R.Maidment and G.W.Tauxe, "Computer Time and Memory Requirements for DP and DDDP in Water Resources System Analysis", Water Resources Research, Vol. 11, No. 5, pp.621-628, 1975

A.Colorni and G.Fronza, "Reservoir Management via Reliability Programming", Water Resources Research, Vol. 12, No. 1, pp.85-88, 1976

P.Nopmongkol and A.J.Askew, "Multi-level Incremental Dynamic Programming", Water Resources Research, Vol. 12, No. 6, pp.1286-1290, 1976

H.H.Happ, "Optimal Power Dispatch - A Comprehensive Survey", IEEE Transactions on Power Apparatus and Systems, Vol. PAS-96, No. 3, pp 841-854, May/June 1977

V.Klemes, "Discrete Representation of Storage for Stochastic Reservoir Optimisation", Water Resources Research, Vol. 13, No. 1, pp.149-158, 1977

R.M.Hirsh, J.L.Cohon and C.S.ReVelle, "Gains from Joint Operation of Multiple Reservoir Systems", Water Resources Research, Vol. 13, No. 2, pp.239-245, 1977

C.R.Gagnon and J.F.Bolton, "Optimal Hydro Scheduling at the Bonneville Power Administration", IEEE Transactions on Power Apparatus and Systems, Vol. PAS-97, No. 3, pp 772-776, May/June 1978

M.H.Houck and J.L.Cohon, "Sequential explicitly Stochastic Linear Programming Models: A Proposed Method for Design and Management of Multi Purpose Reservoir System", Water Resources Research, Vol. 14, No. 2, pp.161-168, 1978

W.S.Chu and W.W-G.Yeh, "A Nonlinear Programming Algorithm for Real-Time Hourly Reservoir Operations", Water Resources Research, Vol. 14, No. 5, pp.1048-1063, 1978

T.S.Dillon, K.W.Edwin, H.D.Kocs and R.J.Taud, "Integer Programming Approach to the Problem of Optimal Unit Commitment with Probabilistic Reserve Determination", IEEE Transaction on Power Apparatus and Systems - 97, No. 6, pp.2154-2166, Nov./Dec., 1978

S.Gal, "Optimal Management of a Multireservoir Water Supply System", Water Resources Research, Vol. 15, No. 4, pp.737-749, 1979

D.M.Murray and S.J.Yakowitz, "Constrained Differential Dynamic Programming and its Application to Multireservoir Control", Water Resources Research, Vol. 15, No. 5, pp.1017-1027, 1979

D.J.Thampapillai and J.A.Sinder, "Trade_off for Multiobjective Planning Through Linear Programming", Water Resources Research, Vol. 15, No. 5, pp.1028-1034, 1979

G.W.Tauxe, R.R.Inman and D.M.Mades, "Multiobjective Dynamic Programming with Application to a Reservoir", Water Resources Research, Vol. 15, No. 6, pp.1403-1408, 1979

S.Rahman, "Power System Operation Scheduling Using Separable Programming", Electric Power Systems Research, Vol. 2, No. 4, pp. 292-303, December 1979

R.R.Shoults, S.K. Chang, S.Helmick and W.M.Grady, "A Practical Approach to Unit Commitment, Economic Dispatch and Savings Allocation for Multiple-Area Pool Operation with Import/Export constraints", IEEE Transaction on Power Apparatus and Systems -99, No. 2, pp 625-633, March/April 1980

M.Sniedovich, "Analysis of a Chance Constrained Reservoir Control Model", Water Resources Research, Vol. 16, No. 5, pp.849-853, 1980

D.W.Ross and S.Kim, "Dynamic Economic Dispatch of Generation", IEEE Transactions on Power Apparatus and Systems-99, No. 6, pp 2060-2068, Nov./Dec. 1980

J.G.Wright, A.Bose and G.B.Sheble, "Generation Dispatch with Reserve Margin Constraints Using Linear Programming", IEEE Transaction on Power Apparatus and systems -100, No. 1, pp.252-258, January 1981

H.Mukai, J.Singh, J.H.Spare and J.Zaborszky, "A Reevaluation of the Normal Operating State Control of the Power System Using Computer Control and System Theory:Part II: Dispatch Targeting", IEEE Transactions on Power Apparatus and Systems-100, No. 1, pp 309-317, January 1981

E.F.Joeres,G.J.Seus and H.M.Engelmann, "The Linear Decision Rule(LDR) Reservoir Problem with Correlated Inflows", Water Resources Research, Vol. 17, No. 1, pp.18-24, 1981

J.L.Viviani and J.T.Heydt, "Stochastic Optimal Energy Dispatch", IEEE Transactions on Power Apparatus and Systems-100, No. 7, pp 3221-3228, July 1981

G.S.Lauer, N.R.Sandell Jr., D.P.Bertsekas and T.A.Posbergh, "Solution of Large-Scale Optimal Unit Commitment Problems", IEEE Transaction on Power Apparatus and Systems -101, No. 1, pp.79-86, January 1982

W.G.Wood, "Spinning reserve Constrained Static and Dynamic Economic Dispatch", IEEE Transactions on Power Apparatus and Systems-101, No. 2, pp 381-388, February 1982

M.E.El-Havary and J.K.Landrigan, "Optimum Operation of Fixed Head Hydro-Thermal Electric Power Systems", IEEE Transactions on Power Apparatus and Systems-101, No. 3, pp 547-554, March 1982

A.Tugreon, "Incremental Dynamic Programming May Yield Nonoptimal Solution", Water Resources Research, Vol. 18, No. 6, pp.1599-1604, 1982

K.Aokl and T.Satoh, "Economic Dispatch with Network Security Constraints Using Parametric Quadratic Programming", IEEE Transactions on Power Apparatus and Systems-101, No. 12, pp 4548-4556, December 1982

A.I.Cohen and M.Yoshimura, "A Branch and Bound Algorithm for Unit Commitment", IEEE Transaction on Power Apparatus and Systems -102, No. 2, pp.444-451, February 1983

L.Roy and N.D.Rao, "New Algorithm for Real-time optimal Dispatch of Active and reactive Power Generation Retaining Nonlinearity", IEEE Transactions on Power Apparatus and Systems-102, No. 4, pp 832-842, April 1983

M.V.F.Pereira and L.M.V.G.Pinto, "Application of Decomposition Techniques to the Mid-Short-Term Scheduling of Hydrothermal Systems", Proceedings of the PICA, pp.193-200, June 1983

K.D.Le, J.T.Day, B.L.Cooper and E.W.Gibbons,"A Global Optimisation Method for Scheduling Thermal Generation, Hydro Generation and Economy Purchases", IEEE Transaction on Power Apparatus and Systems -102, No. 7, pp.1986-1993, July 1983

J.S.Luo, E.F.Hill and T.H.Lee, "Power System Economic Dispatch via Network Approach", IEEE Transactions on Power Apparatus and Systems-103, No. 6, pp 1242-1248, June 1984

C.E.Lin and G.L.Viviani, "Hierarchical Economic Dispatch for Piecewise Quadratic Cost Functions", IEEE Transactions on Power Apparatus and Systems-103, No. 6, pp 1170-1175, June 1984

R.Mota-Palomino and V.Quintana, "A Penalty Function - Linear Programming Method and Solving Power System Constrained Economic Operation Problems", IEEE Transactions on Power Apparatus and Systems-103, No. 6, pp 1414-1422, June 1984

M.Ozden, "A Binary State DP Algorithm for Operation Problems of Multireservoir Systems", Water Resources Research, Vol. 20, No. 1, pp.9-14, 1984

J.J.Shaw and D.P.Bertsekas, "Optimal Scheduling of Large Hydrothermal Power Systems", IEEE Transaction on Power Apparatus and Systems -104, No. 2, pp.286-294, February 1985

J.Carpentier, "To be or not to be Modern, That is the Question for Automatic Generation Control(point of view of utility engineer)", Electric Power and Energy Systems, Vol 7, No. 2, pp 81-91, April 1985

S.D.Helmich and R.R.Sholts, "A Practical Approach to an Interim Multiarea economic Dispatch Using Limited computer Resources", IEEE Transactions on Power Apparatus and Systems-106, No. 6, pp 1400-1404, June 1985

G.L.Kusic and H.A.Putnam, "Dispatch and Unit Commitment Including Commonly Owned Units", IEEE Transaction on Power Apparatus and Systems -104, No. 9, pp.2408-2412, September 1985

M.Piekutowski and I.A.Rose, "A Linear Programming Method for Unit Commitment Incorporating Generation Configuration, Reserve and Flow Constraints", IEEE Transaction on Power Apparatus and Systems -104, No. 12, pp.3510-3516, December 1985

H.Hibibollahzadeh and J.A.Bubenko, "Application of Decomposition Techniques to Short-Term Operation Planning of Hydrothermal Power Systems", IEEE Transaction on PWRS-1, No. 1, pp.41-47, February 1986

A.Kuppurajulu and P.Ossowski, "An Integrated Real-time Closed Loop Controlled for Normal and Emergency Operation of Power Systems", IEEE Transaction on PWRS-1, No. 1, pp.242-249 February 1986

G.B.Sheble and L.L.Grigsby, "Decision Analysis Solution of the Unit Commitment Problem", Electric Power Systems Research, Vol. 10 No. 11, pp.85-93, November 1986

M.V.F.Pereira, L.M.Pinto and A.Montichelly, "Economic Dispatch with Security Constrained Rescheduling", Electric Power and Energy Systems, Vol. 9, No. 2, pp 97-104, April 1987

W.L.Snyder, H.D.Powell Jr. and J.C.Rayburn, "Dynamic Programming Approach to Unit Commitment", IEEE Transaction on PWRS-2, No. 2, pp.339-350, May 1987

R.Nieva, A.Inda and I.Guillen, "Lagrangian Reduction of Search-Range for Large Scale Unit Commitment", IEEE Transaction on PWRS-2, No. 2, pp. 465-473, May 1987

G.A.Maria and J.A.Findlay, "A Newton Optimal Power Flow Program for Ontario Hydro EMS", IEEE Transactions on PWRS-2, No. 3, pp 579-584, August 1987

K.Aoki, T.Satoh, M.Itoh, T.Ichimori and K.Masegi, "Unit Commitment in a Large Scale Power System Including Fuel Constrained Thermal and Pumped Storage Hydro", IEEE Transaction on PWRS-2, No. 4, pp.1077-1084, November 1987

H.Brannlund, DSjelvgren and J.A.Bubenko, "Short-Term Generation Scheduling with Security Constraints", IEEE Transaction on PWRS-3, No. 1, pp.310-316, February 1988

F.Zhuang and F.D.Galiana, "Towards a More Rigorous and Practical Unit Commitment by Lagrangian Relaxation", IEEE Transaction on PWRS-3, No. 2, pp.763-773, May 1988

K.Y.Kee, J.L.Ortiz, M.A.Mohtadi and J.M.Park, "Optimal Operation of Large Scale Power Systems", IEEE Transactions on PWRS-3, No. 2, pp 413-420, May 1988

F.N.Lee, "Short-Term Unit Commitment - A New Method", IEEE Transaction on PWRS-3, No. 2, pp. 421-428, May 1988

W.J.Hobbs, G.Hermon, S.Warner and G.B.Sheble, "An Enhanced Dynamic Programming Approach for Unit Commitment", IEEE Transaction on PWRS-3, No. 3, pp.1201-1205, August 1988

S.K.Tong and S.M.Shahidehpour, "Combination of Lagrangian Relaxation and Linear Programming Approaches for fuel Constrained Unit Commitment Problems", IEE Proceedings, Vol. 136, Part C, No. 3, pp.162-174, May 1989

D.S.Sjølvgren, H.Brannlund and T.S.Dillon, "Large-scale Nonlinear Programming Applied to Operations Planning", Electric Power Systems Research, Vol. 11, No.3, pp. 213-217, 1989

S.K.Tong and S.M.Shahidehpour, "An Innovative Approach to Generation Scheduling in Large-Scale Hydro Thermal Power Systems with Fuel Constrained Units", IEEE Transaction on PWRS-5, No. 2, pp.665-673, May 1990

N.Chowdhury and R.Billinton, "Unit Commitment in Interconnected Generating Systems Using a Probabilistic Technique", IEEE Transaction on PWRS-5, No. 4, pp. 1231-1237, November 1990

Z.Ouyang and S.M.Shahidehpour, " Short Term Unit Commitment Expert system", Electric Power Systems Research, Vol. 18, No. 1, pp.1-13, December 1990

S.Ruzic and N.Rajakovic, "A New Approach for Solving Extended Unit Commitment Problem", IEEE Transaction on PWRS-6, No. 1, pp.269-275, February 1991

Z.Ouyang and S.M.Shahidehpour, "Heuristic Multi-Area Unit Commitment with Economic Dispatch", IEE Proceedings, Part C, Vol. 138, No. 3, pp.242-252, May 1991

Z.Ouyang and S.M.Shahidehpour, "An Intelligent Dynamic Programming for Unit Commitment Application", IEEE Transaction on PWRS-6, No. 3, pp.1203-1209, August 1991

S.K.Tong, S.M.Shahidehpour and Z.Ouyang, "A Heuristic Short-Term Unit Commitment", IEEE Transaction on PWRS-6, No. 3, pp.1210-1216, August 1991

F.N.Lee and Q.Chen, "Unit Commitment Risk with Sequential Rescheduling", IEEE Transaction on PWRS-6, No. 3, pp. 1017-1023, August 1991

C.C.Su and Y.Y.Hsu, "Fuzzy Dynamic Programming: An Application to Unit Commitment", IEEE Transaction on PWRS-6, No. 3, pp.1231-1237, August 1991

Y.Y.Hsu, C.C.Su, C.C.Liang, C.J.Lin and C.T. Huang, "Dynamic Security Constrained Multi-Area Unit Commitment", IEEE Transaction on PWRS-6, No. 3, pp.1049-1055, August 1991

Z.Ouyang and S.M.Shahidehpour, "A Hybrid Artificial Neural Network - Dynamic Programming Approach to Unit Commitment", IEEE Transaction on PWRS-7, No. 1, pp. 236-242, February 1992

F.N.Lee and Q.Feng, "Multi-Area Unit Commitment", IEEE Transactions on PWRS-7, No. 2, pp. 591-599, May 1992

Z.Ouyang and S.M.Shahidehpour, "A Multi-Stage Intelligent System for Unit Commitment", IEEE Transaction on PWRS-7, No. 2, pp. 639-646, May 1992

H.Sasaki, M.Watanabe, J.Akubokawa, N.Yorino and R.Yokoyama "A Solution Method of Unit Commitment by Artificial Neural Networks", IEEE Transaction on PWRS-7, No. 3, pp. 974-981, August 1992

J.Batut and A.Renaud, "Daily generation Scheduling Optimisation with Transmission Constraints: A New Class of Algorithms", IEEE Transaction on PWRS-7, No. 3, pp. 982-989, August 1992

C.Wang and S.M.Shahidehpour, "A Decomposition Approach to Non-Linear Multi-Area Generation Scheduling with Tie-Line Constraint Using Expert

Systems”, IEEE Transaction on PWRS-7, No. 4, pp. 1409-1418, November 1992

M.D.Ilic, J.R.Lacalle-Melero, FNishimura, W.Schenler, D.Shirmohammadi, A.Crough and A.Catelli, “Short-Term Economic Energy Management in a Competative Utility Enviroment”, IEEE Transaction on PWRS-8, No. 1, pp. 198-206, February 1993

M.V.Rakic and Z.M.Markovic, “Short-Term Operation and Power Exchange Planning of Hydro-Thermal Power Systems”, IEEE Transaction on PWRS-9, No. 1, pp. 359-365, February 1994

S.Binato and M.V.F.Ferreira, “Decentralized Planning of Hydroelectric Power Systems”, IEEE Transaction on PWRS-10, No. 1, pp. 492-498, February 1995

P.-H.Chen and H.-C.Chang, “Large-Scale Economic Dispatch by Genetic Algorithm”, IEEE Transaction on PWRS-10, No. 4, pp. 1919-1926, November 1995

C.Lyra and L.R.M.Ferreira, “A Multiobjective Approach to the Short-Term Scheduling of a Hydroelectric Power System”, IEEE Transaction on PWRS-10, No. 4, pp. 1750-1755, November 1995

S.A.Kazarlis, A.G.Bakirtzis and V.Petridis, “A Genetic Algorithm Solution to the Unit Commitment Problem”, IEEE Transaction on PWRS-11, No. 1, pp. 83-92, February 1996

X.Bai and S.M.Shahidehpour, "Hydro-Thermal Scheduling by Tabu Search and Decomposition Method", IEEE Transaction on PWRs-11, No. 2, pp. 968-974, May 1996