

Oracle® Project Manufacturing Implementation Manual

Release 11i \

Part No. A75094_01

March 2000

ORACLE

Oracle® Project Manufacturing Implementation Manual Release 11i

The part number for this book is Part No. A75094_01.

Copyright 2000, Oracle Corporation. All rights reserved.

Primary Authors: Satya Anur, Mahesh Damodare, Linda Riggins

Major Contributors: Roger Goossens, Elizabeth Looney

The Programs (which include both the software and documentation) contain proprietary information of Oracle Corporation; they are provided under a license agreement containing restrictions on use and disclosure and are also protected by copyright, patent and other intellectual and industrial property law. Reverse engineering, disassembly or decompilation of the Programs is prohibited.

Program Documentation is licensed for use solely to support the deployment of the Programs and not for any other purpose.

The information contained in this document is subject to change without notice. If you find any problems in the documentation, please report them to us in writing. Oracle Corporation does not warrant that this document is error free. Except as may be expressly permitted in your license agreement for these Programs, no part of these Programs may be reproduced or transmitted in any form or by any means, electronic or mechanical, for any purpose, without the express written permission of Oracle Corporation.

If the Programs are delivered to the US Government or anyone licensing or using the Programs on behalf of the US Government, the following notice is applicable:

RESTRICTED RIGHTS LEGEND

Programs delivered subject to the DOD FAR Supplement are 'commercial computer software' and use, duplication and disclosure of the Programs including documentation, shall be subject to the licensing restrictions set forth in the applicable Oracle license agreement. Otherwise, Programs delivered subject to the Federal Acquisition Regulations are 'restricted computer software' and use, duplication and disclosure of the Programs shall be subject to the restrictions in FAR 52.227-19, Commercial Computer Software - Restricted Rights (June, 1987). Oracle Corporation, 500 Oracle Parkway, Redwood City, CA 94065."

The Programs are not intended for use in any nuclear, aviation, mass transit, medical, or other inherently dangerous applications. It shall be licensee's responsibility to take all appropriate fail-safe, back up, redundancy and other measures to ensure the safe use of such applications if the Programs are used for such purposes, and Oracle disclaims liability for any damages caused by such use of the Programs.

Oracle is a registered trademark and ConText, Enabling the Information Age, Oracle7, Oracle8, Oracle8i, Oracle Access, Oracle Application Object Library, Oracle Financials, Oracle Discoverer, Oracle Web Customers, Oracle Web Employees, Oracle Workflow, Oracle Work in Process, PL/SQL, Pro*C, SmartClient, SQL*, SQL*Forms, SQL*Loader, SQL*Menu, SQL*Net, SQL*Plus, and SQL*Report are trademarks or registered trademarks of Oracle Corporation. Other names may be trademarks of their respective owners.

Table of Contents

Preface

Audience for This Guide	xiv
How To Use This Guide	xiv
Finding Out What's New	xv
Other Information Sources	xvi
Online Documentation.....	xvi
Related User Guides.....	xvi
User Guides Related to All Products	xvii
User Guides Related to This Product	xviii
Reference Manuals	xix
Installation and System Administration Guides.....	xxi
Training and Support.....	xxii
Do Not Use Database Tools to Modify Oracle Applications Data	xxiii

1 Project Manufacturing

Overview of Project Manufacturing	1-2
Project Manufacturing Features	1-8

2 Setting Up

Overview of Setting Up	2-2
Related Product Setup Steps	2-2
Setup for Project Manufacturing without Cost Collection	2-5
Setup Flowchart for Project Manufacturing without Cost Collection	2-5
Setup Checklist For Oracle Project Manufacturing without Cost Collection	2-6

Setup Steps for Oracle Project Manufacturing without Cost Collection	2-7
Setup for Project Manufacturing with Cost Collection	2-12
Setup Flowchart for Project Manufacturing with Cost Collection	2-12
Setup Checklist For Oracle Project Manufacturing with Cost Collection (B)	2-14
Setup Steps for Oracle Project Manufacturing with Cost Collection	2-15
Setup Organization	2-22
Organization Classification.....	2-22
Setup Organization Hierarchy	2-24
Organization Hierarchy.....	2-24
Inventory Organization in the Hierarchy	2-25
Setup Project Manufacturing Organization Parameters	2-25
Project Information Region	2-26
Setup Inventory Organization Parameters	2-26
Project Information Region	2-26
Costing Region.....	2-28
Setup Stock Locators	2-29
Locator Flexfield	2-29
Definition	2-29
Use of Locator	2-30
Dynamically Creating Stock Locator	2-30
Project Manufacturing Validation	2-32
Validation in Purchasing.....	2-32
Validation in Inventory	2-33
Validation in WIP	2-33
Validation in Shipping.....	2-36
Implementation Notes	2-37
New Parameter - PJM: Allow Cross Project Issues.....	2-37
Setup Department in Manufacturing	2-37
Manufacturing Transactions to Project Transaction Source Mapping	2-38
Organization Costing Information.....	2-38
Setup Expenditure Types and Expenditure Type Classes.....	2-39
Associating Expenditure Types to Multiple Expenditure Type Classes.....	2-39
Linking Expenditure Types to Cost Elements.....	2-40
Setup Cost Sub-elements and Link to Expenditure Types	2-40
Assign Material Overhead Rates to Items	2-41

Setup Project.....	2-42
Setup Cost Groups.....	2-43
Setup WIP Accounting Classes.....	2-45
Common Project Assignment	2-46
Setup Planning Groups.....	2-46

3 Project References and Validation Logic

References to Other Oracle Products	3-2
Project Manufacturing Validations	3-4

4 Project Definition

Defining Project Parameters	4-2
Seiban Number Wizard	4-6

5 Task AutoAssignment

Overview	5-2
Benefits	5-5
Examples	5-10
Implementation Procedure	5-14
Implementation Notes	5-15

6 Project Manufacturing Costing and Billing

Costing of Project Inventory Transactions.....	6-2
Procurement Transactions.....	6-2
Project Cost Transfers	6-2
Borrow/Payback Transactions (Temporary Transfers).....	6-4
Other Average Cost Transactions	6-7
Costing of Project WIP Transactions.....	6-10
WIP Accounting Class	6-10
Resource Charging	6-10
Setup WIP Completion Costing Options	6-10
Common Items Issued to Project WIP Jobs	6-11
Outside Processing	6-12
Project Scrap Transactions.....	6-12

Overhead Application	6-13
Cost Processing	6-16
Process Flow	6-16
Programs.....	6-18
Transfer Invoice Charges to Projects	6-19
PA Transaction Import	6-20
Expenditure Type Classes for Project Manufacturing	6-22
Project Billing and Revenue Recognition	6-24
Project Cost of Goods Sold (COGS)	6-25
General Ledger Posting	6-27

7 Project MRP

Overview	7-1
Project MRP Setup.....	7-2
Project MRP Planning Logic	7-4
Planner Workbench in Project MRP	7-13
Implementation Notes	7-15

8 Supply Chain Projects

Overview of Supply Chain Projects	8-2
Major Features	8-2
Process Flow	8-3
Simple Example	8-6

9 Project Procurement

Overview of Project Procurement	9-2
Project Procurement Flow	9-2
Project Commitments	9-4
Implementation Notes	9-5
Multiple Projects On One Document.....	9-5
Auto-Create RFQ	9-7
Receiving.....	9-7

10 Workflows

Overview of Project Manufacturing Workflows	10-1
PJM Contract Type Project Definition Process	10-2
PJM Indirect Type Project Definition Process	10-7
Project Manufacturing Integration Exception Process	10-11

11 ATO/PTO in Project Manufacturing

Overview of ATO/PTO in Project Manufacturing	11-2
Process Flow.....	11-3
Project/Task Defaulting Logic for ATO/PTO Options.....	11-7

12 Project Quality Collection

Overview of Project Quality Collection.....	12-2
Quality Process Flow.....	12-3

13 Project Order Management and Fulfillment

Project Order Management and Fulfillment.....	13-2
Overview.....	13-2
Project Quotations and Sales Orders	13-2
Project Fulfillment	13-2
Project RMA	13-3
Project Order Import.....	13-3
Project Drop Shipments.....	13-3
Other Implementation Notes	13-7
ATP by Project.....	13-7

14 Model/Unit Effectivity

Overview	14-2
Model/Unit Effectivity - Example	14-2
Multiple Model/Unit Number Ranges for the Same End Item.....	14-6
Model/Unit Effectivity - Setup.....	14-9
Model/Unit Effectivity Features in Oracle Project Manufacturing.....	14-10
Generate and Maintain Model/Unit Numbers.....	14-12

Bills of Material for Model/Unit Effective items	14-14
Engineering Change Orders for Model/Unit Effective items.....	14-18
Order Management for Model/Unit Effective Items	14-21
Planning of Model/Unit Effective Items.....	14-23
Procurement of Model/Unit Effective Items.....	14-29
Store, Track, and Manage Inventory of Model/Unit Effective Items	14-31
WIP Features for Model/Unit Numbers.....	14-35
Flow Manufacturing Support for Model/Unit Numbers.....	14-38
Shipping of Model/Unit Effective Items.....	14-38
Implementation Notes	14-39

15 Web Workbench

Overview	15-2
Viewing Project Details	15-2
Inquiry Details for Project Inquiry (Projects Only).....	15-4
Inquiry Details for Project Inquiry (with Projects).....	15-6
Inquiry Details for Project Inquiry (without Projects).....	15-7
Column Details on Drilldowns.....	15-7

16 Period Close in Project Manufacturing

Overview	16-2
-----------------------	-------------

17 Oracle Project Manufacturing Without Oracle Projects

Overview	17-2
Setup.....	17-3
Flow in the Project environment.....	17-4
Summary.....	17-10

Send Us Your Comments

Oracle Project Manufacturing Implementation Manual, Release 11i

Part No. A75094-01

Oracle Corporation welcomes your comments and suggestions on the quality and usefulness of this publication. Your input is an important part of the information used for revision.

- Did you find any errors?
- Is the information clearly presented?
- Do you need more information? If so, where?
- Are the examples correct? Do you need more examples?
- What features did you like most about this manual?

If you find any errors or have any other suggestions for improvement, please indicate the chapter, section, and page number (if available). You can send comments to us in the following ways:

- FAX - 650.506.7294. Attn: Oracle Project Manufacturing
- Postal service:
Oracle Corporation
Oracle Manufacturing Documentation
500 Oracle Parkway, 30p5
Redwood Shores, CA 94065
USA

If you would like a reply, please give your name, address, and telephone number below.

If you have problems with the software, please contact your local Oracle Support Services.

Preface

Audience for This Guide

Welcome to Release 11*i* of the Oracle Project Manufacturing Implementation Manual.

This guide assumes you have a working knowledge of the following:

- The principles and customary practices of your business area.
- Oracle® Project Manufacturing
If you have never used Oracle® Project Manufacturing, we suggest you attend one or more of the Oracle® Project Manufacturing training classes available through Oracle University.
- The Oracle Applications graphical user interface.
To learn more about the Oracle Applications graphical user interface, read the *Oracle Applications User Guide*.

See Other Information Sources for more information about Oracle Applications product information.

How To Use This Guide

This guide contains the information you need to implement Oracle® Project Manufacturing.

This preface explains how this user guide is organized and introduces other sources of information that can help you. This guide contains the following chapters:

- Chapter 1 provides an overview of Oracle Project Manufacturing, including integration, business flow, and features.
- Chapter 2 contains set up information for Oracle Project Manufacturing.
- Chapter 3 provides references to other Oracle application user guides and explains the use of validations in Project Manufacturing.
- Chapter 4 provides information on defining project parameters and working with seiban numbers.
- Chapter 5 explains how to use the Task Auto-Assignment feature to allocate resources and materials based on rules.
- Chapter 6 discusses the four processes used to cost in Oracle Inventory and Oracle Work in Process transactions, to transfer such costs to Oracle Projects, and to import and correct the costed transactions in Oracle Projects.

- Chapter 7 describes the Project MRP feature in Oracle Project Manufacturing and explains the Project MRP netting logic with specific examples for soft and hard pegging.
- Chapter 8 explains how to use supply chain planning for multi-organization purposes in an Oracle Project Manufacturing environment.
- Chapter 9 describes the key features related to project procurement.
- Chapter 10 describes the Oracle Project Manufacturing Workflows that allow you to define contract and indirect projects and to schedule exception notifications.
- Chapter 11 explains how to process Available-To-Order and Pick-To-Order orders in Oracle Project Manufacturing.
- Chapter 12 explains quality collection in a project manufacturing environment.
- Chapter 13 describes the use of order management and fulfillment capabilities in a project manufacturing environment.
- Chapter 14 explains the use of model/unit number effectivity in Oracle Project Manufacturing.
- Chapter 15 describes how to query project data using the Web Workbench.
- Chapter 16 outlines the steps required to close accounting periods in a project manufacturing environment.
- Chapter 17 describes the use of Oracle Project Manufacturing without the installing Oracle Projects.

Finding Out What's New

From the HTML help window for Oracle® Project Manufacturing, choose the section that describes new features or what's new from the expandable menu. This section describes:

- New features in 11*i*. This information is updated for each new release of Oracle® Project Manufacturing.
- Information about any features that were not yet available when this user guide was printed. For example, if your system administrator has installed software from a mini pack as an upgrade, this document describes the new features.

Other Information Sources

You can choose from many sources of information, including online documentation, training, and support services, to increase your knowledge and understanding of Oracle® Project Manufacturing.

If this guide refers you to other Oracle Applications documentation, use only the Release 11*i* versions of those guides unless we specify otherwise.

Online Documentation

All Oracle Applications user's guides are available online (HTML and PDF). Implementation manuals are available in PDF. The technical reference guides are available in paper format only. Note that the HTML documentation is translated into over twenty languages.

The HTML version of user's guide is optimized for onscreen reading, and you can use it to follow hypertext links for easy access to other HTML guides in the library. When you have an HTML window open, you can use the features on the left side of the window to navigate freely throughout all Oracle Applications documentation.

- You can use the Search feature to search by words or phrases.
- You can use the expandable menu to search for topics in the menu structure we provide. The Library option on the menu expands to show all Oracle Applications HTML documentation.

You can view HTML help in the following ways:

- From an application window, use the help icon or the help menu to open a new Web browser and display help about that window.
- Use the documentation CD.
- Use a URL provided by your system administrator.

Your HTML help may contain information that was not available when this guide was printed.

Related User Guides

Oracle® Project Manufacturing shares business and setup information with other Oracle Applications products. Therefore, you may want to refer to other user guides when you set up and use Oracle® Project Manufacturing.

You can read the guides online by choosing Library from the expandable menu on your HTML help window, by reading from the Oracle Applications Document

Library CD included in your media pack, or by using a Web browser with a URL that your system administrator provides.

If you require printed guides, you can purchase them from the Oracle store at <http://oraclestore.oracle.com>.

User Guides Related to All Products

Oracle Applications User Guide

This guide explains how to navigate the system, enter data, and query information, and introduces other basic features of the GUI available with this release of Oracle® Project Manufacturing (and any other Oracle Applications product).

You can also access this user guide online by choosing *Getting Started and Using Oracle Applications* from the Oracle Applications help system.

Oracle Alert User Guide

Use this guide to define periodic and event alerts that monitor the status of your Oracle Applications data.

Oracle Applications Implementation Wizard User Guide

If you are implementing more than one Oracle product, you can use the Oracle Applications Implementation Wizard to coordinate your setup activities. This guide describes how to use the wizard.

Oracle Applications Developer's Guide

This guide contains the coding standards followed by the Oracle Applications development staff. It describes the Oracle Application Object Library components needed to implement the Oracle Applications user interface described in the *Oracle Applications User Interface Standards*. It also provides information to help you build your custom Oracle Developer forms so that they integrate with Oracle Applications.

Oracle Applications User Interface Standards

This guide contains the user interface (UI) standards followed by the Oracle Applications development staff. It describes the UI for the Oracle Applications products and how to apply this UI to the design of an application built by using Oracle Forms.

User Guides Related to This Product

Oracle Bills of Material User's Guide

This guide describes how to create various bills of materials to maximize efficiency, improve quality and lower cost for the most sophisticated manufacturing environments. By detailing integrated product structures and processes, flexible product and process definition, and configuration management, this guide enables you to manage product details within and across multiple manufacturing sites.

Oracle Cost Management User's Guide

This guide describes how to use Oracle Cost Management in either a standard costing or average costing organization. Cost Management can be used to cost inventory, receiving, order entry, and work in process transactions. It can also be used to collect transaction costs for transfer to Oracle Projects. Cost Management supports multiple cost elements and multiple subelements. It also provides comprehensive valuation and variance reporting.

Oracle Engineering User's Guide

This guide enables your engineers to utilize the features of Oracle Engineering to quickly introduce and manage new designs into production. Specifically, this guide details how to quickly and accurately define the resources, materials and processes necessary to implement changes in product design.

Oracle Flow Manufacturing User's Guide

This guide provides an overview of the processes of flow manufacturing and describes how to use Oracle Flow Manufacturing's features to support the entire flow manufacturing process from line design and balancing to production execution.

Oracle Inventory User's Guide

This guide describes how to define items and item information, perform receiving and inventory transactions, maintain cost control, plan items, perform cycle counting and physical inventories, and set up Oracle Inventory.

Oracle Manufacturing Scheduling User's Guide

This guide describes how to use Oracle Manufacturing Scheduling to view and reschedule single discrete jobs or the entire shop floor. Specifically, this guide details

how to easily use the drag and drop functionality to view and reschedule jobs, operations, and resources.

Oracle Order Management User's Guide

This guide describes how to enter sales orders and returns, copy existing sales orders, schedule orders, release orders, create price lists and discounts for orders, run processes, and create reports.

Oracle Projects User's Guide

This guide explains how to set up projects for use in project manufacturing and project accounting.

Oracle Purchasing User's Guide

This guide describes how to create and approve purchasing documents, including requisitions, different types of purchase orders, quotations, RFQs, and receipts. This guide also describes how to manage your supply base through agreements, sourcing rules and approved supplier lists. In addition, this guide explains how you can automatically create purchasing documents based on business rules through integration with Oracle Workflow technology, which automates many of the key procurement processes.

Oracle Work in Process User's Guide

This guide describes how Oracle Work in Process provides a complete production management system. Specifically this guide describes how discrete, repetitive, assemble-to-order, project, flow, and mixed manufacturing environments are supported.

Reference Manuals

Oracle Technical Reference Manuals

Each technical reference manual contains database diagrams and a detailed description of database tables, forms, reports, and programs for a specific Oracle Applications product. This information helps you convert data from your existing applications, integrate Oracle Applications data with non-Oracle applications, and write custom reports for Oracle Applications products.

You can order a technical reference manual for any Oracle Applications product you have licensed.

Oracle Automotive Implementation Manual

This manual describes the setup and implementation of the Oracle Applications used for the Oracle Automotive solution.

Oracle Manufacturing and Distribution Open Interfaces Manual

This manual contains up-to-date information about integrating with other Oracle Manufacturing applications and with your other systems. This documentation includes open interfaces found in Oracle Manufacturing.

Oracle Applications Message Reference Manual

This manual describes all Oracle Applications messages. This manual is available in HTML format on the documentation CD-ROM for Release 11i.

Oracle Project Manufacturing Implementation Manual

This manual describes the setup steps and implementation for Oracle Project Manufacturing.

Oracle Receivables Tax Manual

This manual provides everything you need to know about calculating tax within Oracle Receivables, Oracle Order Management, Oracle sales, and Oracle Web Customers. It includes information about implementation procedures, setup forms and windows, the Oracle Receivables Tax calculation process, tax reports and listings, and open interfaces.

Oracle Self-Service Expenses Implementation Guide

This guide explains in detail how to configure Oracle Self-Service Expenses and describes its integration with Oracle Payable and Oracle Projects.

Oracle Self-Service Web Applications Implementation Manual

This manual describes the setup steps for Oracle Self-Service Web Applications and the Web Applications dictionary.

Installation and System Administration Guides

Oracle Applications Concepts

This guide provides an introduction to the concepts, features, technology stack, architecture, and terminology for Oracle Applications Release 11*i*. It provides a useful first book to read before an installation of Oracle Applications. This guide also introduces the concepts behind, and major issues, for Applications-wide features such as Business Intelligence (BIS), languages and character sets, and self-service applications.

Installing Oracle Applications

This guide provides instructions for managing the installation of Oracle Applications products. In Release 11*i*, much of the installation process is handled using Oracle One-Hour Install, which minimizes the time it takes to install Oracle Applications and the Oracle 8*i* Server technology stack by automating many of the required steps. This guide contains instructions for using Oracle One-Hour Install and lists the tasks you need to perform to finish your installation. You should use this guide in conjunction with individual product user guides and implementation guides.

Upgrading Oracle Applications

Refer to this guide if you are upgrading your Oracle Applications Release 10.7 or Release 11.0 products to Release 11*i*. This guide describes the upgrade process in general and lists database upgrade and product-specific upgrade tasks. You must be at either Release 10.7 (NCA, SmartClient, or character mode) or Release 11.0 to upgrade to Release 11*i*. You cannot upgrade to Release 11*i* directly from releases prior to 10.7.

Using the AD Utilities

Use this guide to help you run the various AD utilities, such as AutoInstall, AutoPatch, AD Administration, AD Controller, Relink, and others. It contains how-to steps, screenshots, and other information that you need to run the AD utilities.

Oracle Applications Product Update Notes

Use this guide as a reference if you are responsible for upgrading an installation of Oracle Applications. It provides a history of the changes to individual Oracle Applications products between Release 11.0 and Release 11*i*. It includes new

features and enhancements and changes made to database objects, profile options, and seed data for this interval.

Oracle Applications System Administrator's Guide

This guide provides planning and reference information for the Oracle Applications System Administrator. It contains information on how to define security, customize menus and online help, and manage processing.

Oracle Workflow Guide

This guide explains how to define new workflow business processes as well as customize existing Oracle Applications-embedded workflow processes. You also use this guide to complete the setup steps necessary for any Oracle Applications product that includes workflow-enabled processes.

Training and Support

Training

We offer a complete set of training courses to help you and your staff master Oracle Applications. We can help you develop a training plan that provides thorough training for both your project team and your end users. We will work with you to organize courses appropriate to your job or area of responsibility.

Training professionals can show you how to plan your training throughout the implementation process so that the right amount of information is delivered to key people when they need it the most. You can attend courses at any one of our many Educational Centers, or you can arrange for our trainers to teach at your facility. We also offer Net classes, where training is delivered over the Internet, and many multimedia-based courses on CD. In addition, we can tailor standard courses or develop custom courses to meet your needs.

Support

From on-site support to central support, our team of experienced professionals provides the help and information you need to keep Oracle® Project Manufacturing working for you. This team includes your Technical Representative, Account Manager, and Oracle's large staff of consultants and support specialists with expertise in your business area, managing an Oracle server, and your hardware and software environment.

Do Not Use Database Tools to Modify Oracle Applications Data

We STRONGLY RECOMMEND that you never use SQL*Plus, Oracle Data Browser, database triggers, or any other tool to modify Oracle Applications tables, unless we tell you to do so in our guides.

Oracle provides powerful tools you can use to create, store, change, retrieve, and maintain information in an Oracle database. But if you use Oracle tools such as SQL*Plus to modify Oracle Applications data, you risk destroying the integrity of your data and you lose the ability to audit changes to your data.

Because Oracle Applications tables are interrelated, any change you make using an Oracle Applications form can update many tables at once. But when you modify Oracle Applications data using anything other than Oracle Applications forms, you might change a row in one table without making corresponding changes in related tables. If your tables get out of synchronization with each other, you risk retrieving erroneous information and you risk unpredictable results throughout Oracle Applications.

When you use Oracle Applications forms to modify your data, Oracle Applications automatically checks that your changes are valid. Oracle Applications also keeps track of who changes information. But, if you enter information into database tables using database tools, you may store invalid information. You also lose the ability to track who has changed your information because SQL*Plus and other database tools do not keep a record of changes.

About Oracle

Oracle Corporation develops and markets an integrated line of software products for database management, applications development, decision support and office automation, as well as Oracle Applications. Oracle Applications provides the E-business Suite, a fully integrated suite of more than 70 software modules for financial management, Internet procurement, business intelligence, supply chain management, manufacturing, project systems, human resources and sales and service management.

Oracle products are available for mainframes, minicomputers, personal computers, network computers, and personal digital assistants, enabling organizations to integrate different computers, different operating systems, different networks, and even different database management systems, into a single, unified computing and information resource.

Oracle is the world's leading supplier of software for information management, and the world's second largest software company. Oracle offers its database, tools,

and application products, along with related consulting, education and support services, in over 145 countries around the world.

Your Feedback

Thank you for using Oracle® Project Manufacturing and this user guide.

We value your comments and feedback. This guide contains a Reader's Comment Form you can use to explain what you like or dislike about Oracle® Project Manufacturing or this user guide. Mail your comments to the following address or call us directly at (650) 506-7000.

Oracle Applications Documentation Manager
Oracle Corporation
500 Oracle Parkway
Redwood Shores, CA 94065
U.S.A.

Or, send electronic mail to **appsdoc@us.oracle.com**.

Project Manufacturing

This chapter provides an overview of Oracle Project Manufacturing. The following topics are included:

- Overview of Project Manufacturing
- Project Manufacturing Features

Overview of Project Manufacturing

Oracle Project Manufacturing Release 11i incorporates a new set of features and enhancements designed to fully support companies in the Engineer-To-Order, Make-To-Order, Seiban, and Aerospace and Defense industries. These industries are characterized by the need to plan, track, procure, and cost based on project, contract, or Seiban numbers.

Oracle Project Manufacturing supports the following key areas:

- Project manufacturing sales management and fulfillment, including drop shipments
- Project manufacturing advanced supply chain planning
- Project manufacturing costing
- Project manufacturing procurement
- Project manufacturing shop floor execution, including Flow Manufacturing integration
- Project inventory tracking
- Project manufacturing quality management
- Assemble-To-Order and Pick-To-Order environments

In addition, Oracle Projects provides the following main features:

- Project work breakdown structure definition
- Project management system integration
- Project budgeting and funding
- Project cost tracking and control
- Project cash forecasting
- Project billing
- Project revenue recognition
- Project archive and purge

The following key features are supported specifically for the Aerospace and Defense industry:

- Model/unit effectivity (serial effectivity)

- Borrow payback
- Hard and soft full pegging across the supply chain
- Group netting
- Actual costing (moving weighted average method)
- Complete integration with Oracle Advanced Planning and Scheduling
- Complete integration with Oracle Flow Manufacturing

New in Release 11i

Oracle Project Manufacturing added the following features in Release 11i:

- Model/unit effectivity (serial effectivity)
- Borrow payback
- Invoice cost transfer (for actual costing)
- Common project
- Inter-org project manufacturing costing
- Task auto-assignment workbench
- Workflow-based schedule exception messages
- Workflow-based project MRP exception messages, with project reschedule-in, reschedule-out, and cancellation messages
- Common supply netting for hard pegged material
- Workflow-based manufacturing project definition flow
- Seiban wizard and Seiban job costing
- Project data in EDI purchase order and purchase order change transactions
- Workflow-based inventory move orders for project material
- Project manufacturing organization parameters
- Project web workbench support for inquiry of PSI (project status inquiry including project actuals and commitments), project expenditures, project budgets and budget revisions, WIP job drill down to operations and material, cost group history drill down, and flow schedules
- Project RMAs

- Pick Release by project and task
- Integration with Oracle Advanced Supply Chain Planning

Oracle Projects added the following major features in Release 11i:

- Project cash forecasting (integration with Oracle Cash Management)
- Multi-national projects (currency and tax)
- Cost allocations
- Graphical T-Accounts
- Archive and purge
- Inter-company and inter-project billing

For more information on these features, see *Oracle Projects User's Guide*.

Oracle Project Manufacturing Integration

Oracle Project Manufacturing is fully integrated with the Oracle Projects, Oracle Financials, Oracle Human Resources, Oracle Customer Relationship Management, Oracle Business Intelligence System, and Oracle Supply Chain Management product suites.

Figure 1-1 Oracle Project Manufacturing Integration with Oracle Products

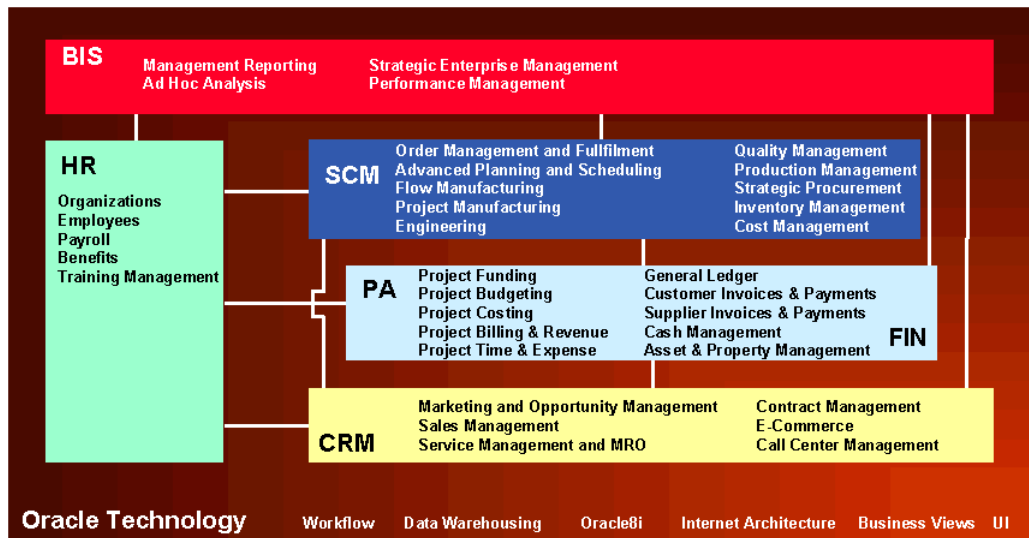

Project Manufacturing Flow

Figure 1-2 portrays a generic high-level Project Manufacturing flow that is typical for the Engineer-To-Order and Aerospace and Defense industry but that is extended to include Business Intelligence, Flow Manufacturing, and Supply Chain scenarios.

Figure 1-2 Generic High-Level Project Manufacturing Flow

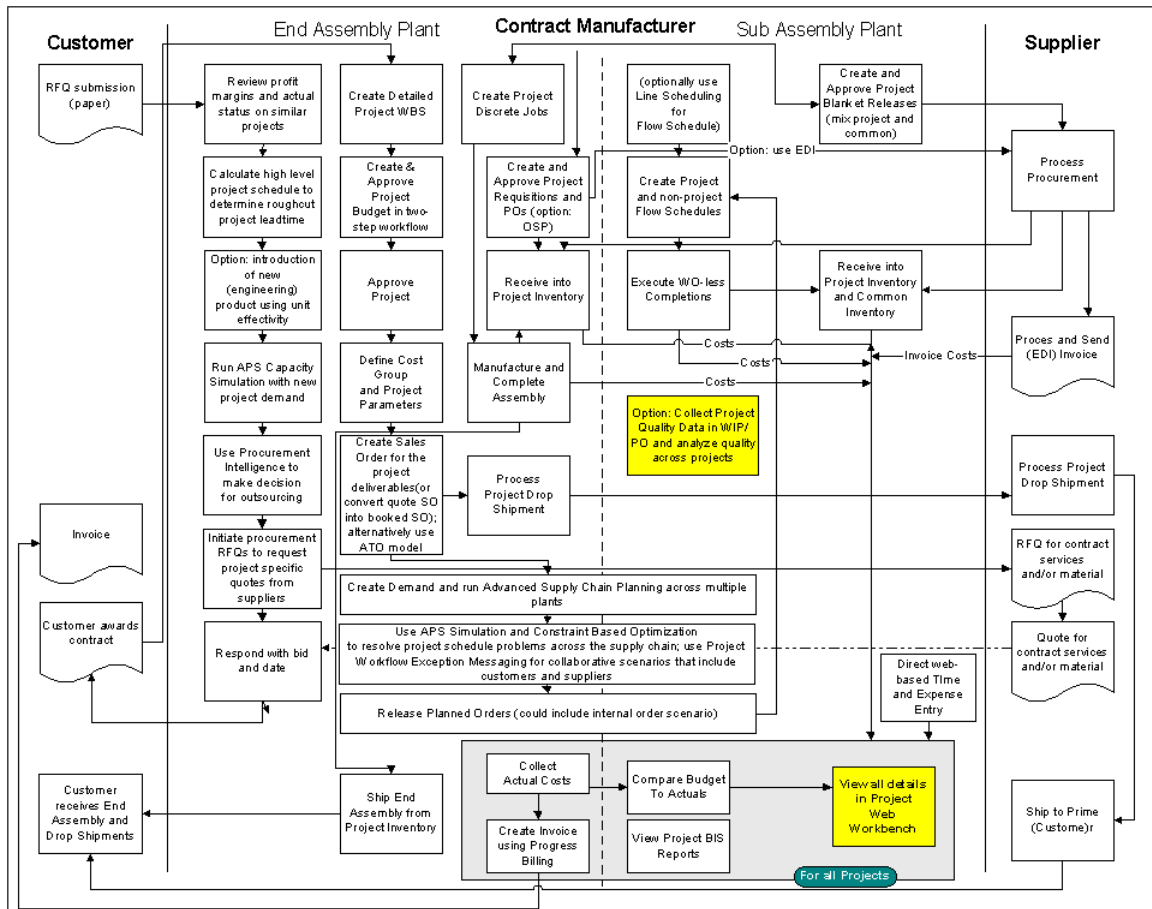

A complete contract cycle typically follows the steps shown in Figure 1-2. A contract cycle begins with a bid and proposal process by Sales and Engineering. This process includes review of profit margins and actual status on similar projects, calculation of a high-level project schedule to determine a rough-cut project duration, engineering reviews with optional new product introduction, infinite or constraint-based capacity simulation, procurement analysis for contract specific out-sourcing and requests for supplier quotes. The final result is a bid.

After the contract is awarded by the customer, the project work breakdown structure (WBS) and the budgeting and reporting requirements are defined and submitted for approval. The WBS represents all project activities including tasks, sub-tasks, work packages, activities, and milestones.

The next step is to drive project demand into the execution and planning system. The planning system runs a single or multiple plans across the supply chain and optimizes as needed based on constraints. Simulation of alternates provides the information needed to determine the optimal scenario. Specific project exception messages are analyzed as the outcome of each planning run. The planning results are forwarded to procurement and the shop floor for execution. Drop shipped material can be directly routed to procurement from order management, bypassing planning.

Shop floor execution uses discrete work orders, flow schedules, or a combination to manufacture (sub)assemblies. Procurement uses either blanket releases or standard purchase orders, optionally based on the project specific supplier quotes, for procured material. All project specific material (hard pegged) is tracked separately in the system, with optional borrowing or permanent transfers from one project to another.

Optionally, you can track project specific quality data and analyze defects and non-conformances.

During execution, direct and indirect actual costs are collected by project. Costs can be analyzed for a specific project or across multiple projects. Based on actuals, you can perform earned value analysis, progress billing, and revenue recognition. During the execution phase, quality data are collected and analyzed by project.

After the project has been shipped and installed at the customer site, final billing, reconciliation, and close-out are executed.

Project Manufacturing Features

The Oracle Project Manufacturing features are illustrated in Figure 1-3. The dependencies between the various products used to provide a full project manufacturing solution are also shown.

Figure 1–3 Oracle Project Manufacturing Features

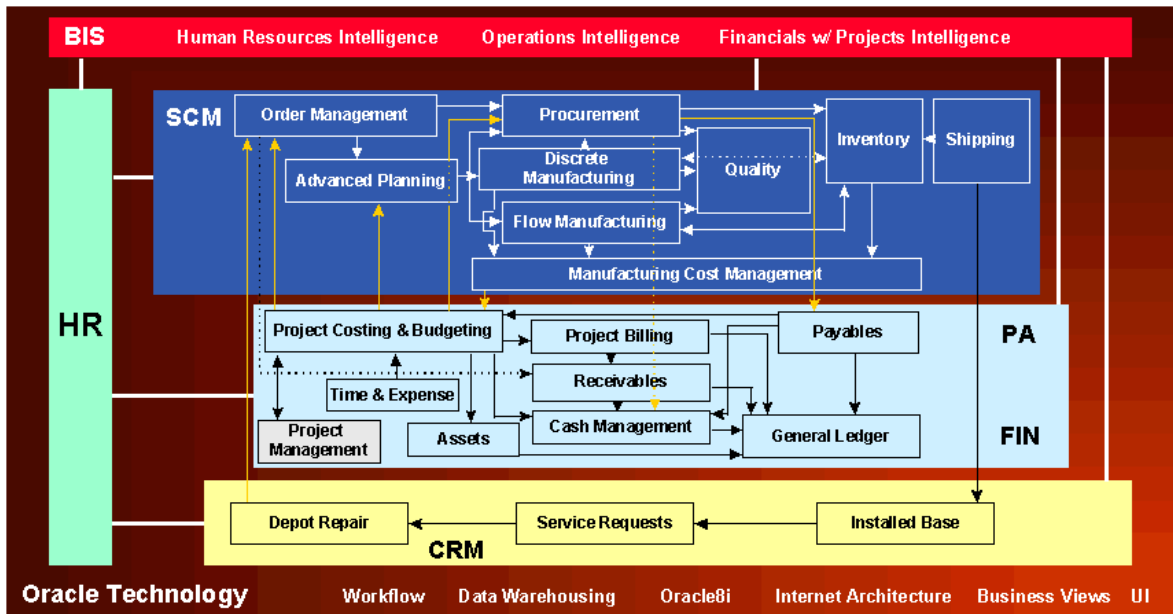

Project Definition

In order to define a project work breakdown structure (WBS), you can use either of three basic methods:

- Define the project structure in a third party project management system and transfer the structure (on-line) into Oracle Projects. Use basic setup data from Oracle Projects (such as project resources, project calendars, and project templates) directly in your third party project management system. Depending on the project management system you need, the Oracle Projects Connect or Oracle Projects Activity Management Gateway product to accomplish this.
- Define the project structure directly in Oracle Projects.

- Define the project structure using the Seiban Number Wizard.

Project or contract specific documentation can be entered into the system using project attachments.

Before releasing the project to collect manufacturing costs, you define the project-related manufacturing parameters for costing and planning purposes. For example, you need to decide whether to allow netting of materials within a project group across multiple projects and whether to track manufacturing costs separately by project or for a group of projects.

Project Budgeting

To track costs against budgets, you can define your budgeting in Oracle Projects. You define budgets directly in Oracle Projects or import budgets from external systems. Oracle Projects' main budgeting features are:

- **Multiple Budget Versions** You can use Oracle Projects to create multiple budget versions that include all of the costs for your project, such as engineering costs, item costs, manufacturing costs, and overheads. Having multiple budget versions allows you to revise your estimate-to-complete many times during a project. Each project can compare the current or baseline budget with earlier versions for analytical reporting.
- **Unlimited Budget Types** You can create different types of budgets. You can create cost budgets, revenue budgets, forecasted revenue budget, approved cost budget, and more.
- **Time Phased Budgeting** You can create user-defined time periods or use existing calendars in Oracle General Ledger or Oracle Projects to establish multiple budgeting periods.
- **Budget Extensions** You can use budget extensions to accommodate your company's budgeting needs.
- **Budget Baselining and Approval** You can baseline a budget and use a workflow-supported approval process for approving your budget.

Budgeting related documents, such as spreadsheets, can be included as budget attachments.

Project Setup for Manufacturing

After your project structure and budgeting have been defined in Oracle Projects, you need to define the Project Manufacturing parameters for your project. These include:

- Default WIP Accounting Class
- Cost Group, if you are using Weighted Average Costing
- Borrow Payback Variance Accounts (optional)
- Planning Group (optional)
- Task Auto-Assignment parameters (optional)
- Expenditure types for IPV, ERV, Freight, Tax, and Miscellaneous; if the parameter Transfer to PA is selected in the Project Manufacturing Organization Parameters
- Project manufacturing costing information:
 - Link new project expenditure types to new manufacturing cost elements and cost sub-elements (only when using new cost elements)
 - Link new manufacturing departments to new projects expenditure organizations (only when using new departments)
 - Optionally, define expenditure types for Invoice Price Variance, Exchange Rate Variance, Freight, Tax, and Miscellaneous Invoice Costs
 - Optionally, define borrow payback accounts

Project Sales Management

Project sales management activities include recording customer quotation documents, project specifications, quotation and sales order information, and fulfillment.

Oracle Project Manufacturing supports:

- **Project Quotations and Sales Orders** Oracle Order Management allows you to specify quotation and sales orders. A quotation can be copied easily to a sales order. Quotation, and sales order lines can be linked to projects and project tasks.
- **Project RMA** Oracle Order Management allows you to process Project RMAs using the line type category 'Return'. Examples of the line types available are return for credit without receipt of goods, return for credit with receipt of goods, and return for replacement.
- **Project Assemble-To-Order (ATO) and Pick-To-Order (PTO)** Oracle Project Manufacturing allows you to use the Oracle Configurator with Oracle Order Management with propagation of project and task on the configured model,

options, and included items. For ATO, the Final Assembly Schedule process will create a WIP Job with the configuration's project and task.

- **Project Drop Shipments** You can specify a project and task on a sales order line and automatically create a project purchase requisition using drop shipment functionality. Drop-shipped materials are shipped directly from supplier to customer.
- **Project Fulfillment** Oracle Order Management and Oracle Shipping Execution support delivery-based shipping with user-definable picking rules for order fulfillment. After manufacturing is complete, finished goods are picked automatically from the project inventory upon pick release. You can also pick all items for a project and task.
- **Project Order Import** If you use external systems to capture order information you can use Order Import to import external sales orders or quotations, including project and task references.

Project Manufacturing Planning

In order to drive project manufacturing planning, you need to enter demand in the system. The system supports three ways of entering demand:

- **Forecasts** You can enter a forecast and link a forecast entry to a project and task.
- **Sales Orders** You can enter a sales order and link a sales order line to a project and task. This can also be accomplished using Order Import functionality.
- **Master Demand/Master Production Schedule** You can enter a master schedule and link a master schedule entry to a project and task. Forecasts and sales orders can be sources for a master schedule.

After demand is created in the system, you can start your planning cycle. The planning cycle can be executed for a plan that spans one organization or an entire supply chain.

To successfully plan material for project execution, you must be able to separate all sources of supply and demand by project, identify components as shared or project specific, track existing inventories by project, and provide visibility to all supply and demand associated with a project.

Oracle Project Manufacturing provides:

- **Hard Pegging** You can plan material requirements while respecting hard pegs on all supply orders and generate planned orders with project/task references. Each item can be hard or soft pegged, thereby allowing various pegging

methods within a bill of material. Hard pegging is also supported in a supply chain planning scenario.

- **Soft Pegging** You can plan materials and soft peg them to the demand. Soft pegging is also supported in a supply chain planning scenario.
- **Group Netting** You can net within a planning group (multiple projects) and you can soft peg items to the projects within the project group.
- **Common Supply Netting** You can net excess common (non-project) supply to hard pegged demand.
- **Graphical Pegging to Project** You can use the object navigator to view your pegging information, such as project, task and sales order, graphically.
- **Planner Workbench** You can use the Planner Workbench to view project exceptions, a project horizontal plan, supply and demand per project, and unit number to simulate new or existing project demand, and to release planned orders by project.
- **Forecast by Project/Task** You can link a project WBS to a forecast entry and run the forecast demand through the planning system. This enables you to plan long term capacity and procurement for your projects.
- **Master Schedule by Project/Task** You can load the MDS/MPS from a project forecast with project sales orders or manually link a project WBS to a schedule entry. You can have project and non-project demand in one schedule.
- **Project Exception Messages** The planning system will generate project related exception messages including: items allocated across projects and tasks, items with excess inventory in a project or task, items with shortage in a project or task, reschedule-in, reschedule-out, and cancellation. You can use the workflow-based exception messages to define collaborative scenarios between internal and external organizations (suppliers and customers).
- **Single Planning Run for all Projects** You can run a single plan for multiple projects at once, thereby eliminating the need to run planning project by project. Oracle Application's fast memory-based planner allows you to execute planning much faster than traditional planning systems.
- **Project Planning Simulation** You can enter new supply and demand entries for new project and tasks or change existing supply and demand due dates directly in the Planner Workbench. On-line net-change simulation lets you view the results of your changes in minutes. This allows you to respond easily to scenarios of fluctuating and unexpected demand or to project management system rescheduling results.

- **Multi-Organization/Multi-Plant and Supply Chain Projects** Using Oracle Project Manufacturing, you can consolidate all costs for the products you manufacture for the same project in multiple plants in Oracle Projects. You can use Oracle Advanced Supply Chain Planning to plan projects across a supply chain with appropriate propagation of project and tasks on internal orders and demand and supply entities.
- **Constraint-Based Optimization** You can use Oracle Advanced Supply Chain Planning to optimize your project material and capacity plans using a variety of constraints and objective functions.
- **Borrow Payback Supply and Demand** The planning engine recognizes borrow payback supply and demand.

Project Manufacturing Execution

The planning cycle results in planned orders that are fed into the execution system:

- Internal orders driven by inter-company supply
- WIP Discrete Jobs for make items (Project Work In Process)
- Flow Schedules for make items (Project Work In Process)
- Purchase Requisitions or Blanket Releases for buy items (Project Procurement)

The execution system addresses the inventory, shop floor, and procurement activities. Project manufacturing costs are collected during execution.

Project Work In Process

Oracle Project Manufacturing supports the following features for Project Work In Process:

- **Project WIP Jobs** You can create WIP Jobs (work orders) with project/task references. Both standard and non-standard WIP Jobs are supported. Standard Project WIP Jobs can be created automatically and released from the Planner Workbench.
- **Project Outside Processing** You can use existing outside processing functionality to support Project Outside Processing. The project/task on the work order is transferred once the outside processed purchase requisition is generated.
- **Project Repair Orders** You can use non-standard WIP Jobs to capture project repair by linking these jobs to a project/task.

- **Project Flow Schedules** You can use flow schedules in a work order-less production environment. Flow schedules can be created and released from the Planner Workbench or Line Scheduling Workbench (Oracle Flow Manufacturing integration).

Project Procurement

Oracle Project Manufacturing supports the following features for Project Procurement:

- **Project Requisitions** You can create requisitions with project/task references. Project requisitions can be defined for inventory and expense destination types. Project requisitions can be implemented automatically from the Planner Workbench.
- **Project Purchase Orders** You can create purchase orders with project/task references. Project purchase orders can be defined for inventory and expense destination types.
- **Project Blanket Releases** You can create purchase blanket releases with project/task references. Project blanket releases can be automatically implemented from the Planner Workbench.
- **Project RFQs** You can create purchase Request For Quotations (RFQ) manually or auto-create a RFQ from a requisition. You can request multiple quotes within one vendor RFQ.
- **Project Supplier Quotes** You can create purchase vendor quotes manually or create a quote from an RFQ.
- **Project Outside Processing** You can create purchase orders for outside processing directly from Oracle Work In Process.

Project Inventory

Tracking inventory by project and dealing with permanent and temporary transfers from one project to another or from common inventory to project inventory is essential for a project-based environment. Oracle Project Manufacturing supports:

- **Project Inventory** You can segregate inventory by project using project locators. Purchase order receipt locators are validated automatically for project purchase orders. You can reference existing project locators or you can dynamically create project locators upon receipt. The issue, back-flush, and completion locators are validated automatically for project WIP jobs and their associated material. Similar logic applies in processing flow schedules using work order-less completions.

- **Project Material Transactions** You can use existing material transactions such as Miscellaneous Issue/Receipt, Move Orders (material transfer within one project), PO Receipt, WIP Issue, WIP Return, and WIP Completion to handle all of your project material transaction needs.
- **Permanent Project to Project Transfers** You can transfer material from one project to another with appropriate transfer of inventory value, using project transfer transactions.
- **Temporary Project to Project Transfers** You can use borrow payback transactions to borrow material from one project to another, with payback being assured against the original value.
- **Common-to-Project and Project-to-Common Transfers** You can use project transfer transactions to transfer material from common inventory to project inventory and vice versa, with appropriate transfer of inventory value.

After completion of the assembly on the project sales order lines, the goods can be shipped to the customer for installation.

Project Manufacturing Costing

During the execution phase, project-related costs can be collected in four ways:

- Import of costs from external systems directly into Oracle Projects' Transaction Import
- Entry of direct labor and expenses directly into Oracle Projects using time and expense entry
- Collection of manufacturing labor, material, and manufacturing overhead in Oracle Cost Management as a result of Work In Process and Inventory transactions
- Import of manufacturing costs from external systems using Oracle Manufacturing Transaction Import

For expense purchases, the invoice costs flow to a project through Oracle Payables. For inventory purchases, the purchase costs flow to a project through Oracle Cost Management upon receiving into destination. As soon as invoices are matched, approved, and posted to the General Ledger, you can transfer the appropriate invoice charges (IPV, ERV, Freight, Tax, and Miscellaneous) to Oracle Projects, using the Invoice Charge Transfer Request.

For inter-company costs, the system transfers costs at cost group value (determined by FOB point), either collapsed into the material element or with elemental details.

Oracle Project Manufacturing supports project costing with the following features:

- **Cost Groups** You can create cost groups and link cost groups to projects to identify and separate costs by item and by project. Costs are tracked using perpetual weighted average costing. You can use one cost group for multiple projects if you want to establish a weighted average cost by item for a group of projects.
- **Linking Project Expense Organizations to Manufacturing Departments** You can link project expense organizations to manufacturing departments to allow for departmental cost visibility and analysis for a project.
- **Common Project** You can define a common project to collect cost for all common material transactions into Oracle Projects. You can use standard tools such as Expenditure Inquiry and Project Status Inquiry to analyze your common project, view commitments and actuals, and compare common and project-specific costs.
- **Linking Project Cost Elements To Manufacturing Cost Elements** You can create user-defined project cost elements (Oracle Projects expenditure types), and manufacturing cost (sub)elements. Project cost elements can be mapped into user definable categories for analysis and reporting. You can specify which project cost elements you will use on an individual project. Oracle Project Manufacturing allows you to link manufacturing cost elements (labor, material, overhead, outside processing), resources, and departments to project cost elements. This allows you to track all costs within a project, whether a given cost's source is purchasing, project direct labor and expenses, shop floor activity, or external systems.

Figure 1–4

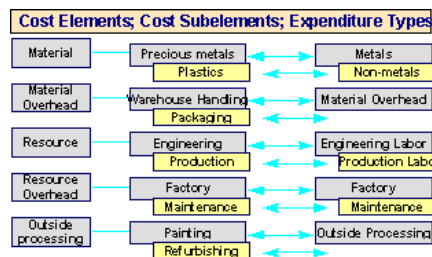

- **Manufacturing Cost Collector** Oracle's Manufacturing Cost Collector allows you to transfer manufacturing costs to Oracle Projects. The engine intelligently

derives all required information such as expenditure organization, expenditure date, and project cost element, automatically. All manufacturing costs are transferred to Oracle Project's Transaction Import for project cost distribution. The Cost Collector also calls the Task Auto Assignment Rules to assign tasks to costed transactions when running a project-only manufacturing scenario.

- **Project Inventory Valuation** You can use the full functionality of Weighted Average Actual Costing in a Project Manufacturing environment. Project inventory material costs will be maintained by project on a perpetual weighted average basis. Common inventory material costs will be maintained by item. All costs are maintained per organization on elemental detail.

Oracle Projects supports costing with the following additional features to keep track of project progress, actual-versus-planned budget, control of project purchase commitments, and reporting:

- **Project Status Inquiry (PSI)** Use this feature to research facts about your project. You can go up and down on your project WBS and obtain project summary information, and drill down to detail transaction information. You can also obtain project commitments, revenue, invoices, unbilled costs, backlog and receivable information. The PSI Extension allows you to pull project information from any part of the database. You can export data in on-line queries to your desktop spreadsheet and reporting tools, to meet the requirements of your company.
- **Project Comparison** Oracle Projects and most project management systems allow you to compare multiple project versions. You can use Oracle Projects to compare baseline and current project budgets.
- **Project Status Reporting** Both Oracle Projects and most third-party project management systems support a large number of project status reports to analyze your project financial status.
- **Project Expenditure Types** You can create user defined project cost elements (expenditure types) and group these elements into categories.

The Oracle Business Intelligence System supports management reporting across all projects and all organizations for revenue and cost incurred. Starting from the top level, you can drill down across the organization and classification hierarchies to the project level.

Project Billing

Oracle Projects is the repository for all project costs. These costs can be used for earned value analysis, which is handled in the third-party project management system. The result of the earned value analysis can trigger project billing.

Within the Project Manufacturing solution, there are three ways to accomplish billing:

- Drive billing from Oracle Order Management using order types (workflows) that interface to Oracle Receivables.
- Drive billing from Oracle Project Billing using billing schedules that interface to Oracle Receivables.
- Use a combination of the first two methods. For example, you might drive project billing from Oracle Project Billing and spare-part billing from Oracle Order Management. If you use Oracle Shipping Execution to ship your project-related assemblies, but not to bill for them, use order types (workflows) that do not interface to Oracle Receivables to avoid double billing.

Project Quality Management

Optionally, you can implement Oracle Quality for managing project quality. Oracle Quality in combination with Oracle Project Manufacturing supports:

- **Project Quality Collection Elements** You can use project and task as quality collection elements.
- **Specify Project on Quality Collection Plan** You can specify a project on a quality collection plan.
- **Project Quality Data Collection** You can collect project and task related quality information using manual entry or Oracle Quality's Data Collection Open Interface.
- **Project Quality Analysis** You can use project and task as selection criteria for quality analysis.

Figure 1-3 includes Oracle financial products that have not been discussed. If you implement an Oracle Projects functionality called Capital Projects, you will generate asset lines for Oracle Assets. All journals from all subsystems will be posted to Oracle General Ledger. Oracle General Ledger is also the place holder for the chart of accounts used throughout the entire system.

Special Features

Oracle Project Manufacturing provides additional special features:

- **Model/Unit Effectivity (Serial Effectivity)** You can define unit effective items and bills of materials, allowing you to implement product structure variations driven by unit number effectivity as opposed to date effectivity. You can engineer, sell, plan, produce, procure, ship, and track against a unit number. Model/Unit Effectivity can be used in a non-project based environment.
- **Task Auto Assignment Workbench** You can use the Task Auto Assignment Workbench to define material and resource rules for task allocation. This feature supports scenarios where you intend to run the manufacturing side under project control only. Task Auto Assignment supports a myriad of rules to assign tasks dynamically to project-only manufacturing transactions for more flexible costing scenarios. For example, instead of allocating all costs for a work order to one task, you could implement rules that allow certain resource cost to be allocated to one task, other resource costs to another task, and material costs to be allocated to yet another.
- **Project Web Workbench** This workbench operates in a separate browser window and allows continuous monitoring of one or more projects. The web workbench shows project related data such as project sales orders, project procurement documents, project discrete jobs with material and operation details, project flow schedules, project cost group with history, project budgeting, project expenditures, and project commitments.
- **Manufacturing Project Definition** This workflow-based process guides the user through the setup steps required to define a project manufacturing project. The process keeps track of completion and can notify a user on steps to be done or completed.
- **Project Schedule Exceptions** This workflow-based process assists users in identifying project schedule inconsistencies. Inconsistencies can be sent to project and task managers using workflow notifications or standard exception reports. The process monitors overdue work orders, procurement documents, and sales orders, as well as out of sync work orders, procurement documents, planning entries, and sales orders.
- **Seiban Number Wizard** The Seiban Number Wizard guides the user in the definition of seiban number, which is visible in the system as a project number. Seiban numbers can be represented as unique numbers using Project Manufacturing without Oracle Projects. For ETO-type seiban or lot-type seiban, you can define a multi-level project structure in Oracle Projects, or a top-level project structure that can be generated through the wizard.

Setting Up

This chapter tells you how to implement Oracle Project Manufacturing. Topics include:

- Overview of Setting Up
- Setup Steps for Oracle Project Manufacturing without Cost Collection
- Setup Steps for Oracle Project Manufacturing with Cost Collection
- Setup Context for Parameters
- Validations
- Implementation Notes

Overview of Setting Up

Oracle Project Manufacturing can be set up with and without Cost Collection. This chapter provides information on how to set up the application in both modes.

Oracle Applications Implementation Wizard

If you are implementing more than one Oracle Applications product, it is recommended that you use the Oracle Applications Implementation Wizard (AIW) to coordinate your setup activities. The Wizard guides you through the setup steps for the applications you have installed, suggesting a logical sequence that satisfies cross-product implementation dependencies and reduces redundant setup steps.

You can use the Wizard to see a graphical overview of setup steps, read online help for a setup activity, and open the appropriate setup window. You can also document your implementation, for further reference and review, by using the Wizard to record comments for each step.

See Also

Oracle Applications Implementation Wizard User's Guide

Related Product Setup Steps

Oracle Project Manufacturing setup includes various setup steps within Oracle Applications products. These steps are discussed in detail in the Overview of Setting Up sections of the respective Oracle product user's guides.

Setup Underlying Oracle Applications Technology

The Wizard guides you through the entire Oracle Applications setup, including system administration. However, if you do not use the Implementation Wizard, you need to complete several other setup steps, including:

- Performing system-wide setup tasks such as configuring concurrent managers and printers
- Managing data security, which includes setting up responsibilities to allow access to a specific set of business data and complete a specific set of transactions, and assigning individual users to one or more of these responsibilities
- Setting up Oracle Workflow

See Also

Oracle Applications Implementation Wizard User's Guide

Oracle Applications System Administrator's Guide

Oracle Workflow Guide

Human Resources/Projects Setup Steps

Refer to the Overview of Setting Up section in the *Human Resources User's Guide* for details of the following setup steps

Step	AIW Reference
Setup Organization	Common Applications
Setup Organization Hierarchy	Common Applications

Inventory Setup Steps

Refer to the Overview of Setting Up section in the *Inventory User's Guide* for details of the following setup steps

Step	AIW Reference
Setup Inventory Organization Parameters for Costing	Common Applications
Setup Stock Locators	Common Applications

Bill of Material Setup Step

Refer to the Overview of Setting Up section in the *Bill of Materials User's Guide* for details of the following setup steps

Step	AIW Reference
Setup Department in Manufacturing	Common Applications

Projects Setup Steps

Refer to the Overview of Setting Up section in the *Projects User's Guide* for details of the following setup steps

Step	AIW Reference
Setup Expenditure Types and Type Classes	Common Applications
Setup Expenditure Types for Cost Elements	Common Applications

Cost Management Setup Step

Refer to the Overview of Setting Up section in the *Cost Management User's Guide* for details of the following setup steps

Step	AIW Reference
Setup Expenditure Types for Cost Sub-elements	Common Applications

Setup for Project Manufacturing without Cost Collection

Setup Flowchart for Project Manufacturing without Cost Collection

This section provides information on how to implement Oracle Project Manufacturing without Oracle Projects Cost Collection.

Some of the steps outlined in this flowchart and setup checklist are Required and some are Optional. Required Step With Defaults refers to setup functionality that comes with pre-seeded, default values in the database; however, you should review those defaults and decide whether to change them to suit your business needs. If you want or need to change them, you should perform that setup step. You need to perform Optional steps only if you plan to use the related feature or complete certain business functions.

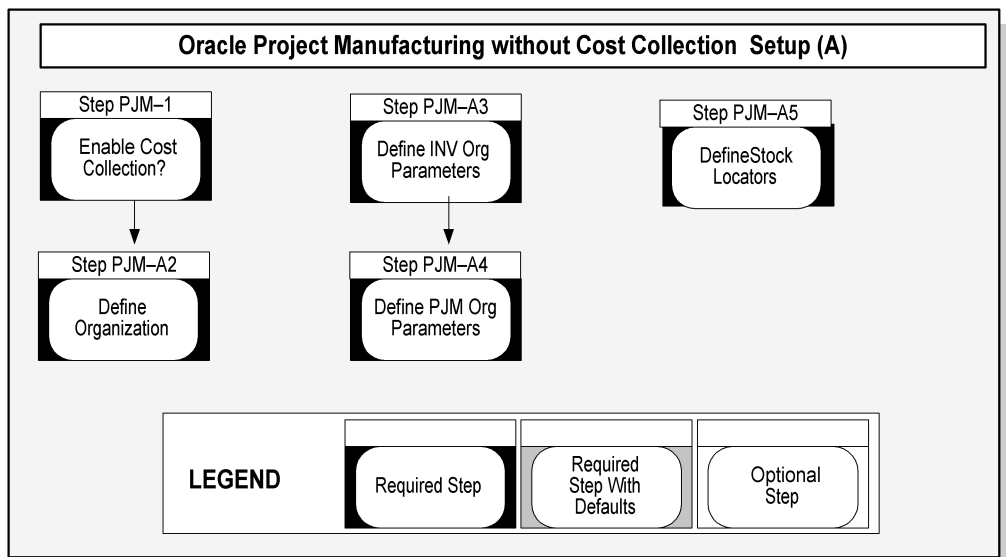

Setup Checklist For Oracle Project Manufacturing without Cost Collection

The following table lists setup steps and a reference to their location within the Wizard. For a detailed description of AIW reference levels, see the *Oracle Applications Implementation Wizard User's Guide*. After you log on to Oracle Applications, complete these steps to implement Master Scheduling/MRP and Oracle Supply Chain Planning

Step No.	Required	Step	AIW Reference
1	Required	Do You Want to Enable Project Cost Collection?	Common Applications
A2	Required	Define Organizations	Common Applications
A3	Required	Define Inventory Organization Parameters	Common Applications
A4	Required for a Project Manufacturing Organization	Define Project Manufacturing Organization Parameters	Common Applications
A5	Required	Define Stock Locators	Common Applications

Setup Steps for Oracle Project Manufacturing without Cost Collection

For each step, a context section indicates whether you need to repeat the step for each set of books, set of tasks, inventory organization, HR organization, or other operating unit under Multiple Organizations.

Step 1 Do You Want to Enable Project Cost Collection?

This step is Required. The implication of this decision is a two-fold one:

- It determines whether manufacturing costs are to be collected and transferred to Oracle Project Accounting;
- It determines what costing method to use. If your answer to this question is Yes, you can only choose Average as the costing method for the organization

Step A2 Define Organizations

This step is Required. An organization should have the following classifications when it is used in a project manufacturing environment without Oracle Projects:

- Project Manufacturing Organization
- Inventory Organization
- MRP Organization (Optional)
- WIP Organization (Optional)
- ECO Department (Optional)
- HR Organization (Optional)

In classifying Project Manufacturing Organization, you can click on the Other button to enable the various PJM Org Parameters. They include:

- **Set Project Reference** You need to enable this check box if you use Project Manufacturing in this organization.
- **Set Control level** In a Seiban organization, the control level should be set to Project as there are no tasks defined for a project. When the control level is set to Project, you can use the project number on all supply and demand entries.
- **Common Project**

Attention: If you do not use Oracle Projects, you do not need to perform this setup.

- **Allow Cross Project Issues** Checking this box will allow you to perform cross project issues for projects belonging to the same planning group and cost group.
- **Allow Cross Unit Issues** Checking this box will allow you to perform cross unit issues within the planning group.
- **Transfer to PA Checkbox**

Attention: If you do not use Oracle Projects, you do not need to perform this setup.

Set Expenditure type

Attention: If you do not use Oracle Projects, you do not need to perform this setup.

Set Variance accounts This is an optional setup used in Borrow/Payback scenarios. You can define new Borrow/Payback variance accounts at the Inventory Organization level. When you perform a payback transaction, the difference between the current average cost and the original borrowing cost will be posted to these new accounts for the borrowing project's cost group.

Step A3 Define Inventory Organization Parameters

If you have already enabled the Costing Method, you can skip this step. Otherwise you need to complete this step. When you install Oracle Project Manufacturing, you will be able to navigate to the Costing region of the Inventory Organization Parameter form. The fields in this region include:

- **Costing Method** You can use either Average or Standard costing methods.

Step A4 Define Project Manufacturing Organization Parameters

This step is required for a Project Manufacturing Organization.

If you have set these parameters in the step Define Organization, you can skip this step. Otherwise, please set the following parameters for each Inventory Organization:

General Tab

- **Set Project Reference** You need to enable this check box if you use Project Manufacturing in this organization.
- **Set Control level** When the control level is set to Project, you can use the project number on all supply and demand entries. Task number is optional. When the control level is set to Task, you must enter the task number if the project number is entered on the supply and demand entities. When the control level is set to either Project or Task, the system will automatically set the value of the hidden Inventory Organization parameter Project Reference to Enabled.

- **Set Common Project**

Attention : If you do not enable Project Cost Collection, you do not need to perform this setup. If you have enabled Project Cost Collection, and if you have defined a common project, then you can assign the common project that is defined in the previous step for each Inventory Organization in the PJM Org Parameters form.

- **Allow Cross Project Issues** Checking this box will allow you to perform cross project issues for projects belonging to the same planning group and cost group.
- **Allow Cross Unit Issues** Checking this box will allow you to control cross unit number issues of unit effective components for an end item Model Unit Number. If checked, then unit effective components for one end item Model Unit Number can be issued to a WIP job for an assembly with a different Model/Unit Number. If unchecked, then unit effective components for one end item Model Unit Number cannot be issued to a WIP job for an assembly with a different Model/unit Number.

Invoice Charges Tab

This region will be displayed only if Oracle Projects or Oracle (What is AP?) is installed.

- **Transfer to PA Checkbox**

Attention : If you do not enable Project Cost Collection, you do not need to perform this setup. If you check the Transfer to PA checkbox, then the transfer program will assume that you want to transfer any invoice charges for that charge type.

- **Set Expenditure type**

Attention : If you do not enable Project Cost Collection, you do not need to perform this setup. If you have enabled Project Cost Collection, and if you have checked the Transfer to PA checkbox, then you must enter the appropriate expenditure types for each of the invoice charge types (IPV/ERV/Freight/Tax/MISC).

Borrow/Payback Tab

- **Set Variance accounts** This is an optional setup used in Borrow/Payback scenarios. You will be able to define a new Borrow/Payback variance account at the Inventory Organization level. When you perform a payback transaction, the difference between the current average cost and the original borrowing cost will be posted to this new account for the borrowing project's cost group. In addition, the variance amount will be posted to Oracle Projects against the borrowing project as a material expenditure.

Step A5 Define Stock Locators

This step is Required.

Project Locator is used to track inventory by project. Oracle Project Manufacturing reserves segment19 and segment20 of the Stock Locator key flexfield to store the project and task numbers. If you are installing Oracle Project Manufacturing for the first time, when you create the first inventory organization and set the Project Control Level to Project or Task, the system automatically enables segment19 and segment20 of the Stock Locator key flexfield.

If you are installing Oracle Project Manufacturing in an existing Oracle Applications installation and are currently using segment19 and segment20 of the

Stock Locator key flexfield, you need to change your current flexfield schema and use other segments instead. The system does not support automatic conversion.

In Project Manufacturing environment, you should ensure that the locator control is set to Dynamic Entry in the Organization Parameters form. Alternatively, you can go to the Master Items form or the Subinventory form to set the locator control at the Item or Subinventory level respectively.

Setup for Project Manufacturing with Cost Collection

Setup Flowchart for Project Manufacturing with Cost Collection

This section provides information on how to implement Oracle Project Manufacturing with Oracle Projects Cost Collection.

Some of the steps outlined in this flowchart and setup checklist are Required and some are Optional. Required Step With Defaults refers to setup functionality that comes with pre-seeded, default values in the database; however, you should review those defaults and decide whether to change them to suit your business needs. If you want or need to change them, you should perform that setup step. You need to perform Optional steps only if you plan to use the related feature or complete certain business functions.

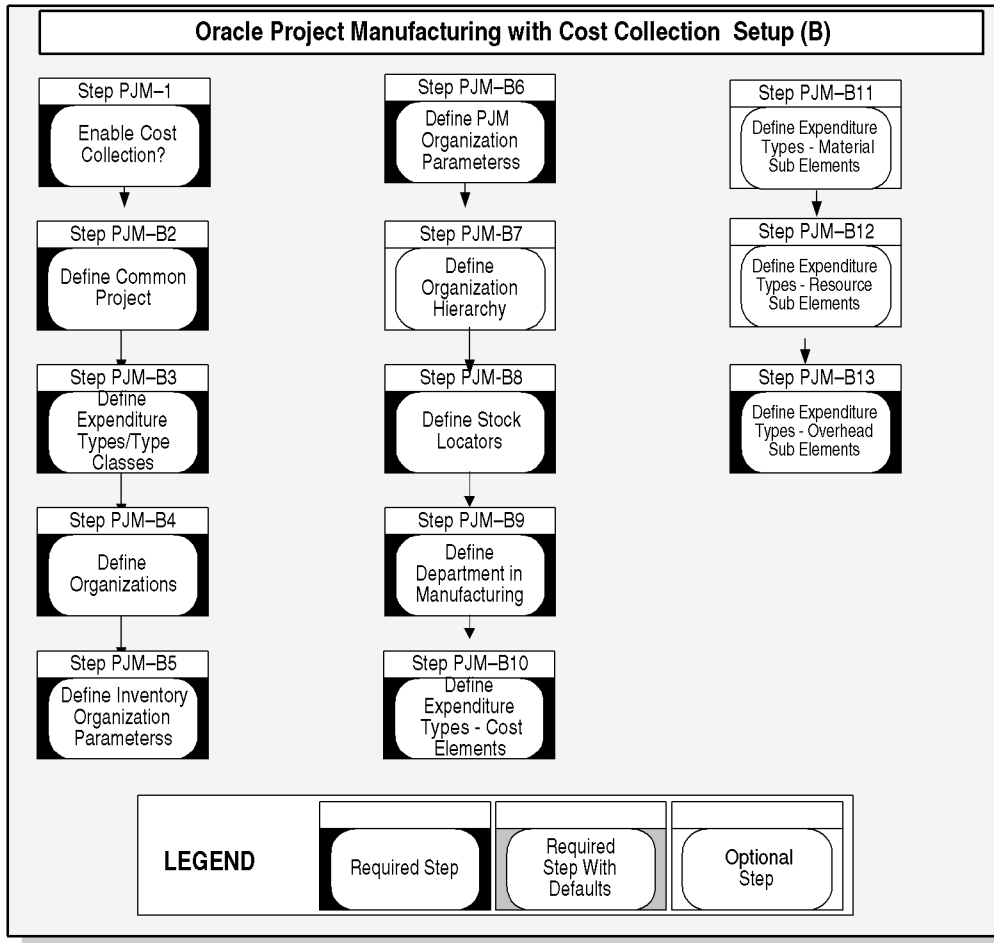

Setup Checklist For Oracle Project Manufacturing with Cost Collection (B)

The following table lists setup steps and a reference to their location within the Wizard. For a detailed description of AIW reference levels, see the *Oracle Applications Implementation Wizard User's Guide*. After you log on to Oracle Applications, complete these steps to implement Master Scheduling/MRP and Oracle Supply Chain Planning

Step No.	Required	Step	AIW Reference
1	Required	Do You Want to Enable Project Cost Collection?	Common Applications
B2	Required	Define Common Project	Common Applications
B3	Required	Define Expenditure Types and Type Classes	Common Applications
B4	Required	Define Organization	Common Applications
B5	Required	Define Inventory Organization Parameters	Common Applications
B6	Required for Project Manufacturing Organizations	Define Project Manufacturing Organization Parameters	Project Manufacturing
B7	Required	Define Organization Hierarchy	Common Applications
B8	Required	Define Stock Locators	Common Applications
B9	Required	Define Department in Manufacturing	Common Manufacturing
B10	Required	Define Expenditure Types for Cost Elements	Common Applications
B11	Required	Define Expenditure Types for Material Sub Elements	Common Applications
B12	Required	Define Expenditure Types for Resource Sub Elements	Common Applications
B13	Required	Define Expenditure Types for Overhead Sub Elements	Common Applications

Setup Steps for Oracle Project Manufacturing with Cost Collection

For each step, a context section indicates whether you need to repeat the step for each set of books, set of tasks, inventory organization, HR organization, or other operating unit under Multiple Organizations.

Step 1 Do You Want to Enable Project Cost Collection?

This step is Required. The implication of this decision is a two-fold one:

- It determines whether manufacturing costs are to be collected and transferred to Oracle Project Accounting;
- It determines what costing method to use. If your answer to this question is Yes, you can only choose Average as the costing method for the organization

Step B2 Define Common Project

This step is Optional.

In a Project Manufacturing environment, you may need to track the costs of Common Items (The items where the on-hand quantities are not tied to a specific project or project/task) to a Common Project, so that you can view the budget, actual and commitment costs for the common project from Oracle Projects.

A Common Project could be created as a normal project in the Projects form. If you have already created a project which would be designated as a Common Project, please skip this step.

To designate a project as a Common Project, continue to the next step Define PJM Org Parameters.

Step B3 Define Expenditure Types and Type Classes

This step is Required.

When you define an expenditure type, you assign it a unit, an expenditure category, a revenue category, and one or more expenditure type classes.

You need to link an expenditure type to cost elements and sub-elements so that Inventory and Work in Process transaction costs can be collected in Oracle Projects as expenditures.

Step B4 Define Organization

This step is Required.

An organization should have the following classifications when it is used in a project manufacturing environment:

- Project Manufacturing Organization
- Project/Task Owning Organization
- Project Expenditure/Event Organization
- Project Invoice Collection Organization
- Inventory Organization
- MRP Organization (Optional)
- WIP Organization (Optional)
- ECO Department (Optional)
- HR Organization (Optional)

In classifying Project Manufacturing Organization, you can click the Other button to enable the various PJM Org Parameters. They include:

- **Set Project Reference** You need to enable this check box if you use Project Manufacturing in this organization.
- **Set Control Level** When the control level is set to Project, you can use the project number on all supply and demand entries. Task number is optional. When the control level is set to Task, you must enter the task number if the project number is entered on the supply and demand entities. When the control level is set to Project, or Task, the system will automatically set the value of the hidden Inventory Organization parameter Project Reference to Enabled.
- **Set Common Project**

Attention: If you do not enable Project Cost Collection, you do not need to perform this setup. If you have enabled Project Cost Collection, and if you have defined a common project, then you can assign the common project that is defined in the previous step for each Inventory Organization in the PJM Org Parameters form.

- **Allow Cross Project Issues** Checking this box will allow you to perform cross project issues for projects belonging to the same planning group and cost group.
- **Allow Cross Unit Issues** Checking this box will allow you to control cross unit number issues of unit effective components for an end item Model Unit

Number. If checked, then unit effective components for one end item Model Unit Number can be issued to a WIP job for an assembly with a different Model/Unit Number. If unchecked, then unit effective components for one end item Model Unit Number cannot be issued to a WIP job for an assembly with a different Model/unit Number.

- **Transfer to PA Checkbox**

Attention: If you do not enable Project Cost Collection, you can skip this step. If you check the Transfer to PA checkbox, then the transfer program will assume that you want to transfer any invoice charges for that charge type.

- **Set Expenditure Type**

Attention: If you do not enable Project Cost Collection, you do not need to perform this setup. If you have enabled Project Cost Collection, and if you have checked the Transfer to PA checkbox, then you must enter the appropriate expenditure types for each of the invoice charge types (IPV/ERV/Freight/Tax/MISC).

- **Set Variance accounts**

This is an optional setup used in Borrow/Payback scenarios. You will be able to define a new Borrow/Payback variance account at the Inventory Organization level. When you perform a payback transaction, the difference between the current average cost and the original borrowing cost will be posted to this new account for the borrowing project's cost group. In addition, the variance amount will be posted to Oracle Projects against the borrowing project as a material expenditure.

Step B5 Define Inventory Organization Parameters

This step is Required.

If you have already defined the Costing Method and chosen Cost Collection, then you can skip this step. Otherwise you need to complete this step.

The fields applicable for Project Manufacturing setup are:

- **Cost Collection**

- **Costing Method**

When Project Cost Collection Enabled is checked, and if you are in a Project Manufacturing Organization (Control Level is set to Project or Task in the PJM Org Parameters form), you can only choose Average as the costing method for the organization. Otherwise, you can use either Average or Standard costing methods.

Step B6 Define PJM Org Parameters

This step is Required for a Project Manufacturing Organization.

If you have set these parameters in the step Define Organization, you can skip this step. Otherwise, please set the following parameters for each Inventory Organization:

General Tab

- **Set Project Reference** You need to enable this check box if you use Project Manufacturing in this organization.
- **Set Control Level** When the control level is set to Project, you can use the project number on all supply and demand entries. Task number is optional. When the control level is set to Task, you must enter the task number if the project number is entered on the supply and demand entities. When the control level is set to Project, or Task, the system will automatically set the value of the hidden Inventory Organization parameter Project Reference to Enabled.
- **Set Common Project**

Attention: If you do not enable Project Cost Collection, you do not need to perform this setup. If you have enabled Project Cost Collection, and if you have defined a common project, then you can assign the common project that is defined in the previous step for each Inventory Organization in the PJM Org Parameters form.

- **Allow Cross Project Issues** Checking this box will allow you to perform cross project issues for projects belonging to the same planning group and cost group.
- **Allow Cross Unit Issues** Checking this box will allow you to control cross unit number issues of unit effective components for an end item Model Unit Number. If checked, then unit effective components for one end item Model Unit Number can be issued to a WIP job for an assembly with a different Model/Unit Number. If unchecked, then unit effective components for one end

item Model Unit Number cannot be issued to a WIP job for an assembly with a different Model/unit Number.

Invoice Charges Tab

(This region will not be displayed if either PA or AP is not installed):

- **Transfer to PA Checkbox**

Attention: If you do not enable Project Cost Collection, you can skip this step. If you check the Transfer to PA checkbox, then the transfer program will assume that you want to transfer any invoice charges for that charge type.

- **Set Expenditure type**

Attention: If you do not enable Project Cost Collection, you do not need to perform this setup. If you have enabled Project Cost Collection, and if you have checked the Transfer to PA checkbox, then you must enter the appropriate expenditure types for each of the invoice charge types (IPV/ERV/Freight/Tax/MISC).

Borrow/Payback Tab

- **Set Variance Accounts** This is an optional setup used in Borrow/Payback scenarios. You will be able to define a new Borrow/Payback variance account at the Inventory Organization level. When you perform a payback transaction, the difference between the current average cost and the original borrowing cost will be posted to this new account for the borrowing project's cost group. In addition, the variance amount will be posted to Oracle Projects against the borrowing project as a material expenditure.

Step B7 Define Organization Hierarchy

This step is Required.

One or more organizations in your organization hierarchy may be your inventory organizations. they may be the project owning organization and can incur project expenditures. For such organizations, you need to:

- Make sure they exist in the Project/Task Owning Organization Hierarchy branch and have Project/Task Owning Organization classification enabled if it is to own projects and/or tasks in the operating unit.
- Make sure they exist in the Expenditure/Event Organization Hierarchy branch and have Project/Task Owning Organization classification enabled if it can incur expenditures for projects in the processing operating unit. In Project Manufacturing, this enables the Inventory Organization to own all the inventory costs.

Step B8 Define Stock Locators

This step is Required.

Project Locator is used to track inventory by project. Oracle Project Manufacturing reserves segment19 and segment20 of the Stock Locator key flexfield to store the project and task numbers. If you are installing Oracle Project Manufacturing for the first time, when you create the first inventory organization and set the Project Control Level to Project or Task, the system automatically enables segment19 and segment20 of the Stock Locator key flexfield.

If you are installing Oracle Project Manufacturing in an existing Oracle Applications installation and are currently using segment19 and segment20 of the Stock Locator key flexfield, you need to change your current flexfield schema and use other segments instead. The system does not support automatic conversion.

In Project Manufacturing environment, you should ensure that the locator control is set to Dynamic Entry in the Organization Parameters form. Alternatively, you can go to the Master Items form or the Subinventory form to set the locator control at the Item or Subinventory level respectively.

Step B9 Define Department in Manufacturing

This step is Required.

Manufacturing Departments in Oracle Manufacturing must be linked to a Project Expenditure Organization. This enables the manufacturing costs (Resources, Overhead, Outside Processing) incurred in that department to be collected under the expenditure organization.

If you have not defined manufacturing departments in Common Manufacturing, you can define them here and link them to the Expenditure Organizations you have defined.

Step B10 Define Expenditure Types for Cost Elements

This step is Required.

You must associate in and out expenditure types with each of the five cost elements so that costs for the following inventory transfer transactions can be collected and transferred to Oracle Projects.

- Subinventory transfers between locators with different projects or tasks.
- Miscellaneous Issue from a project locator.
- Miscellaneous Receipt into a project locator.
- Project related miscellaneous transactions which issue inventory to, or receive inventory from, Projects.
- Issue of common materials to a project WIP job.

Step B11 Define Expenditure Types for Material Sub Elements

This step is Required.

You need to link material sub-element, material overhead sub-element, resource sub-element, overhead sub-element and outside processing sub-element to expenditure type. Since item cost in Oracle Manufacturing is expressed in cost elements and sub-elements, by linking cost elements and sub-elements to project expenditure types, you are effectively mapping the item cost to project expenditures in Oracle Projects. This allows Oracle Projects to collect Oracle Inventory and Work In Process costs as project expenditures.

Step B12 Define Expenditure Types for Resource Sub Elements

This step is Required.

You need to link material sub-element, material overhead sub-element, resource sub-element, overhead sub-element and outside processing sub-element to expenditure type. Since item cost in Oracle Manufacturing is expressed in cost elements and sub-elements, by linking cost elements and sub-elements to project expenditure types, you are effectively mapping the item cost to project expenditures in Oracle Projects. This allows Oracle Projects to collect Oracle Inventory and Work In Process costs as project expenditures.

Step B13 Define Expenditure Types for Overhead Sub Elements

This step is Required.

You need to link material sub-element, material overhead sub-element, resource sub-element, overhead sub-element and outside processing sub-element to expenditure type. Since item cost in Oracle Manufacturing is expressed in cost elements and sub-elements, by linking cost elements and sub-elements to project expenditure types, you are effectively mapping the item cost to project expenditures in Oracle Projects. This allows Oracle Projects to collect Oracle Inventory and Work In Process costs as project expenditures.

Setup Organization

PJM: Setup > Manufacturing > Organizations

INV: Setup > Organizations > Organizations

PA: Setup > Human Resources > Organizations > Define

Organization Classification

Classification	Purpose	Application
Project Manufacturing Organization		Project Manufacturing
Project/Task Owning Organization	Organizations that can own projects and/or tasks in the operating unit.	Oracle Projects
Project Expenditure/Event Organization	Organizations that can own project events (labor and non-labor) can incur expenditures for Projects in the processing operating unit, can own resources and/or resource budgets, and have their own billing schedule	Oracle Projects
Inventory Organization	Allows inventory to be assigned to an organization	Oracle Inventory

An organization may have the following classifications when it is used in a project manufacturing environment.

Classification	Purpose	Application
Project Invoice Collection Organization	Organizations that can process invoices	Oracle Projects (if Project Billing will be used)

MRP Organization	Allows an organization to be included in planning.	Oracle Planning/MRP
ECO Department	Allows access to ECOs when restricted access is enabled.	Oracle Engineering
WIP Organization	Allows an organization to transact work in process	Oracle WIP
HR Organization	Allows an organization to have employees assigned to it	Oracle HR

For example, consider the following three manufacturing and distribution organizations which belong to an Operating Unit Vision Manufacturing: Manufacturing East, Distribution Central, Manufacturing West. Manufacturing East and Manufacturing West are manufacturing facilities where planning, purchasing, stocking and manufacturing goods are taking place. Distribution Central is a warehouse where only planning, purchasing and stocking goods are taking place. All these organization can own projects as well as incur project expenditures.

The following table shows classifications that should be assigned to these organizations:

Organization	Classification
Manufacturing East	Project/Task Owning Organization
	Project Expenditure/ Event Organization
	Project Manufacturing Organization
	Inventory Organization
	MRP Organization
	WIP Organization
	ECO Department
Distribution Central	Project/Task Owning Organization
	Project Expenditure/ Event Organization
	Project Manufacturing Organization
	Inventory Organization
	MRP Organization

Manufacturing West	Project/Task Owning Organization
	Project Expenditure/ Event Organization
	Project Manufacturing Organization
	Inventory Organization
	MRP Organization
	WIP Organization
	ECO Department

See Also

Organizations in Oracle Projects, *Oracle Projects User's Guide*

Setup Organization, *Oracle Inventory User's Guide*

Setup Organization Hierarchy

PJM: Setup > Manufacturing > Organization Hierarchy

PA: Setup > Human Resources > Organizations > Hierarchies

Organization Hierarchy

Organization Hierarchy Concept

In Oracle HRMS, organization hierarchies show reporting lines and other hierarchical relationships among the organizations in your enterprise. For example, you set up a primary reporting hierarchy reflecting the main reporting lines in your enterprise, as established in the organization chart of your enterprise.

Organization Hierarchy in Oracle Projects

An organization hierarchy illustrates the relationships between your organizations. When you define a hierarchy, you tell Oracle Projects which organizations are subordinate to which other organizations. The topmost organization of an organization hierarchy is generally the business group.

You can create as many organization hierarchies as you need for different reporting and processing needs, and you can create multiple versions of an organization hierarchy. Oracle Projects uses the hierarchy version to determine which organizations are used for reporting and processing.

Note: For details on how to use organizations and organization hierarchy in Oracle Projects, see *Organizations in Oracle Projects, Oracle Projects User's Guide*.

Inventory Organization in the Hierarchy

In the previous setup step, organizations were classified as project expenditure organization and/or as project owning and/or project invoice organizations.

You must include your inventory organizations (with classification of project expenditure organization) in the expenditure/event organization hierarchy (defined in the Implementation options in Oracle Projects setup). This allows the projects created in Oracle Projects to be available in the project manufacturing organizations for expenditure charges.

You must include your inventory organizations (with classification of project owning organization) in the Project/Task owning organization hierarchy (defined in the Implementation options in Oracle Projects setup). This allows the projects created in Oracle Projects to use the inventory organizations as project owning organizations in project setup.

In the example discussed in the previous section, you must setup the operating unit Vision Manufacturing as a part of the expenditure/event organization hierarchy and Project/Task owning organization hierarchy in Oracle Projects/Oracle Human Resources and all the inventory organizations Manufacturing East, Distribution Central, and Manufacturing West should be listed as subordinates of Vision Manufacturing.

See Also

Organization Hierarchy in Oracle Projects, Oracle Projects User's Guide

Organization Hierarchy in Oracle Human Resources, Oracle Human Resources User's Guide

Setup Project Manufacturing Organization Parameters

PJM: Setup> Project Manufacturing Organization Parameters

Project Information Region

When you install Oracle Project Manufacturing, you will be able to navigate to the Project Manufacturing Organization Parameter form. The following table explains the fields on this region:

Field	Value	Meaning
Project Reference Enabled	Checked	Project reference will be enabled on demand and supply entities.
	Unchecked	You will not be able to enter project and task data
Project Control Level	Project	You can reference a project number on demand and supply entities. Task number is optional.
	Task	You can reference a project number on demand and supply entities. If a project number is entered, a task number must also be entered

Setup Inventory Organization Parameters

PJM: Setup > Manufacturing > Organization Parameters

INV: Setup > Organization > Organization Parameters

Project Information Region

When you install Oracle Project Manufacturing, you will be able to navigate to the Project Information region of the Inventory Organization Parameter form.

The following table explains the fields on this region:

Field	Value	Meaning
Project Reference Enabled	Checked	Project Reference will be enabled on demand and supply entities.
	Unchecked	You will not be able to enter project and task data.
Project Cost Collection Enabled	Checked	Project Manufacturing Inventory and WIP costs will be transferred to Oracle Projects.
	Unchecked	You can only check this field if Project Reference Enabled is checked. Project Manufacturing Inventory and WIP costs cannot be transferred to Oracle Projects.
Project Control Level	Project	You can reference a project number on demand and supply entities. Task number is optional.
	Task	You can reference a project number on demand and supply entities. If a project number is entered, a task number must also be entered.

Costing Region

When you install Oracle Project Manufacturing, you will be able to navigate to the Costing region of the Inventory Organization Parameter form.

The following table explains the fields on this region:

Field	Value	Meaning
Project Cost Collection Enabled	Checked	When an organization is Project Cost Collection Enabled, project related transactions (Inventory and WIP) can be collected by the Cost Collector in the Cost Management and then imported into Oracle Projects.
	Unchecked	Project manufacturing Inventory and WIP costs cannot be transferred to Oracle Projects.

When Project Reference Enabled and Project Cost Collection Enabled are checked, only the Average costing method is supported. When Project Reference Enabled is checked but Project Cost Collection Enabled is not checked, both Average and Standard costing methods are supported.

Setup Stock Locators

PJM: Setup > Manufacturing > Stock Locators

INV: Setup > Organizations > Stock Locators

Locator Flexfield

Oracle Project Manufacturing reserves segment19 and segment20 of the Stock Locator key flexfield to store the project and task numbers. Users should not attempt to modify these two segments.

If you are installing Oracle Project Manufacturing the first time, when you create the first inventory organization and check the Project Reference Enabled checkbox, the system automatically enables segment19 and segment20 of the Stock Locator key flexfield to hold the project and task references. You have to enable at least one additional segment (e.g. segment1, segment2) to reflect your physical stock location layout.

If you are installing Oracle Project Manufacturing in an existing Oracle Applications installation and are currently using segment19 and segment20 of the Stock Locator key flexfield, you need to change your current flexfield schema and use other segments for your physical stock location layout. The system does not support automatic conversion.

Definition

Project Locator

A Project Locator is a locator with a project or project and task reference. It is also a logical partition of a physical location.

Project Inventory needs to be stocked in a Project Locator and needs to be transacted in and out of a Project Locator. Since Locators can be dynamically created, it is not necessary to predefine Project Locators.

Common Locator

A Common Locator is a locator without a project or project and task reference. It is also a real, physical location.

Note: Although a Project Locator is a logical partition, the system still regards it as a physical locator for physical and cycle counting.

Example 2–1 Project Locator Example

Project Locators differ from Common Locators by the existence of values in the Project and Task segments in the flexfield definition of the Locator. If the structure of the physical location is Row/Rack/Bin, the structure of the Locator flexfield would be Row/Rack/Bin/Project/Task. For example, the concatenated value for a common item in Row 1, Rack 4, Bin 2 would be 1/4/2// while the concatenated value for a project item in Row 1, Rack 4, Bin 2, Project C4501, Task 2.1 would be 1/4/2/C4501/2.1.

Use of Locator

Project Locator is a mechanism to track inventory by project. If an inventory item needs to be identified by project, you need to turn on *Locator Control* for the item.

Since locators can be dynamically created (Locator Control = 'Dynamic Entry Allowed' at item level or subinventory level or organization level), you do not need to predefine all Project Locators.

See Also

Organization Parameter in Oracle Inventory, Oracle Inventory User's Guide - chk where the hierarchy of locator control is listed in Inv user guide

Dynamically Creating Stock Locator

Because Project Manufacturing validates all segments of a Stock Locator Flexfield, users should be wary when dynamically creating Stock Locators. For example, Subinventory A may contain Locator 1.1.1. The user will initially be allowed to create Subinventory B, Locator 1.1.1.Project1.Task1. The addition of the fourth and fifth segments of the Locator flexfield cause it to be different from the Locator in Subinventory A. However, these segments are only logical partitions and the physical location of the items in Subinventory B is still Locator 1.1.1. This violates the required uniqueness of Locators within organizations.

Locator is enforced to be unique in an organization or across organizations. In other words, the physical locators need to be unique in an organization or across organizations. For example, if you select to enforce locator uniqueness within an

organization, the following are valid locators: (assuming 5 segments locator structure with the last 2 segments are project and task).

SubinventoryLocator

Store1.1.1.

FGI2.2.2.

However, you can create the following unique project locators. They are not valid locators because they refer to the same physical locator 1.1.1. which now exists in two different subinventories within the same organization.

SubinventoryLocator

Store1.1.1.P1.T1

FGI1.1.1.P2.T2

Users must exercise discipline when dynamically creating Project Locators and verify that the segments of the logical Locator referring to a physical location do not duplicate a Locator in another subinventory. When attempting to create a unique project Locator, the user should use available List of Values to see existing combinations. As an alternative, the system administrator may not enable dynamically created Locators.

Project Manufacturing Validation

Oracle Project Manufacturing provides defaulting and validation logic in order to keep the use of project locators transparent to the user. The following paragraphs describe the defaulting and validation logic.

for locators within various products. The system validates the project and task segments of a locator based on the value of the Project Control Level parameter you setup in Organization Parameter. The following table describes the validation logic:

Project Control Level	Project Segment	Task Segment
Null	Cannot enter any value.	Cannot enter any value.
Project	Optional.	If Project is entered, Task is optional. If Project is not entered, Task cannot be entered.
Task	Optional.	If Project is entered, Task is mandatory. If Project is not entered, Task cannot be entered.

Validation in Purchasing

Purchase Order Delivery Transaction

When you perform a Purchase Order Delivery Transaction for a project purchase order, the system defaults the project and task from the distribution line of the PO to the receiving locator.

If you define Item Transaction Defaults for receiving locators for specific items in Inventory Setup (assuming these are physical locators), the system concatenates the default locator with the project and task references from the PO distribution line at the time of receiving into Inventory destination.

If you update the project and task on the receiving locator, they are validated against and must exactly match the project and task on the distribution line of the PO.

Purchase Order Return Transaction

When you perform a Purchase Order Return Transaction, the system defaults the project and task from the PO distribution line to the from locator.

If you update the project and task segments of the from locator on a PO return, they are validated against and must exactly match the project and task on the PO distribution line.

Purchase Order Adjustment Transaction

When you perform a Purchase Order Adjustment Transaction, the system defaults the project and task from the PO distribution line to the locator.

If you update the project and task segments of the locator on a PO Adjustment, they are validated against and must exactly match the project and task on the PO distribution line.

Note: You can not use a project locator for the above transactions if the PO distribution does not have project and task.

Validation in Inventory

The system applies the Common Validation logic to the following transactions:

- Miscellaneous Issue
- Miscellaneous Receipt
- Subinventory Transfer
- Locator Transfer
- Interorganization Transfer (Direct)
- Interorganization Transfer (Intransit)
- Cycle Count Adjustment
- Physical Count Adjustment

Validation in WIP

Project Discrete Job Completion Locator

When you create a project discrete job (either manually or from the Planner Workbench), the system defaults the project and task from the project discrete job to the project and task segments of the completion locator. If you have assigned a completion locator (common locator) to the routing, the system concatenates the common locator segments with the project and task to create a project locator.

When you update the project and task on the Project Discrete Job, the system re-defaults the project and task segments of the Completion Locator.

If you update the project and task segments of the Completion Locator, they are validated against and must exactly match the project and task on the Project Discrete Job. They cannot be null.

Project Discrete Job Completion Transaction

When you perform a Completion Transaction, the system defaults the Completion Locator from the Project Discrete Job.

If you update the project and task segments of the Completion Locator, they are validated against and must exactly match the project and task on the project discrete job. They cannot be null.

Project Discrete Job Material Requirements

When you define a project discrete job for an item that has a bill of material, the bill is copied to the project discrete job. If the components are *hard pegged* (their Pegging item attribute is set to either Hard Pegging or End Assembly/Hard Pegging), then the system defaults the project and task from the project discrete job header to their supply locator. If you have assigned supply locators (common locator) on the bills of material, the system concatenates the supply locators with the project and task to create a project locator.

If you update the project and task on the project discrete job, the system re-defaults the project and task segments of any hard pegged components.

If you update the project and task segments of the supply locator for any components of a project discrete job, they are validated against and must either match the project and task on the project discrete job or be null.

If the components are *soft pegged*, (their Pegging attribute is set to either Soft Pegging or End Assembly/Soft Pegging) the system does not default the project and task segments to the supply locators. You can optionally override this and assign the project and task to the supply locator. The system validates the project and task against the project and task from the project discrete job header.

Project Discrete Job Component Issue Transaction

The system validates the supply locator for a Component Issue Transaction for a project discrete job. The supply locator must satisfy one of the following criteria:

- No project/task reference on the supply locator.

- The project and task on the supply locator must exactly match the project and task on the project discrete job.
- Same project but different task, if the profile *PJM Organization Parameter: Allow Cross Project Issues* is set to Yes and the project belongs to a planning group.
- A different project with the same cost group and planning group association as the project on the project discrete job. The profile *PJM Organization Parameter: Allow Cross Project Issues* is set to Yes.

Project Discrete Job Return Assembly to WIP Transaction

If you enter or updates the project and task segments of the completion locator on a Return Assembly to WIP Transaction, they are validated against and must exactly match, the project and task on the project discrete job.

Project Discrete Job Component Return Transaction

If you enter or update the project and task segments of the supply locator on a Component Return, they are validated and must satisfy one of the following criteria:

- No project/task reference on the supply locator.
- The project and task on the supply locator must exactly match the project and task on the project discrete job.
- Same project but different task, if the profile *PJM Organization Parameter: Allow Cross Project Issues* is set to Yes and the project belongs to a planning group.
- A different project with the same cost group and planning group association as the project on the project discrete job. The profile *PJM Organization Parameter: Allow Cross Project Issues* is set to Yes.

Note: You can not use a project locator as completion locator or supply locator for all the above transactions against a non-project (common) discrete job.

Project Work Order-less Completion

When you perform a project work order-less completion, you must specify the assembly, quantity, project and/or task and other information. If you have setup a default completion locator on the routing, the system defaults it in for the transaction. If you have not setup a default completion locator, you can specify one

for the transaction. When the transaction is saved, the system defaults the project and task from the transaction to the completion locator.

Work order-less completion automatically backflushes all Operation Pull, Assembly Pull, and Push components. The system builds the supply locators for the components by concatenating the supply locator from the item and the project and/or task you specify.

Validation in Shipping

Pick Release

When you perform Pick Release for a project sales order, the system ensures that you can only pick release from the project locators that have the same project and task as the sales order line.

Implementation Notes

New Parameter - PJM: Allow Cross Project Issues

A new parameter Allow Cross Project Issues, has been created to enable cross project issues between projects which have the same cost group and planning group.

Cross Project Issue

Cross project issue is only allowed for WIP component issue, WIP component backflush and WIP component return transactions. You need to set the profile *PJM: Allow Cross Project Issues* to Yes.

Cross Project Issue is not allowed if the two projects belong to two different cost groups.

Cross Project Issue does not support for Sales Order Issue.

Setup Department in Manufacturing

Linking Department to Expenditure Organization

Manufacturing Departments A Manufacturing Department is an area within your organization that consists of one or more people, machines, or suppliers, where you want to collect costs, apply overhead, and compare load to capacity. You assign a department to each operation in a routing, and assign resources that are available for that department.

You setup a Manufacturing Department in Oracle Bills of Material.

Expenditure Organizations An Expenditure Organization is an organization that can own project events (labor and non-labor) and can incur expenditures for projects in the processing operating unit.

You setup an Expenditure Organization by classifying the organization as Project Expenditure/Event Organization in Oracle Inventory/Oracle Human Resources.

Linking Manufacturing Departments to Expenditure Organization in Oracle Projects

In a Project Manufacturing environment, you must link manufacturing departments (in Oracle Manufacturing) to a Project Expenditure Organization when you setup up a department. This enables the manufacturing costs (Resources, Overhead, Outside Processing) incurred in that department to be collected under the expenditure organization.

In the following diagram, the Fabrication department defined in Oracle Bills of Material must be mapped to a Project Expenditure Organization, as indicated by the arrows. This mapping allows manufacturing costs to be collected at the desired level of the project hierarchy. As an example, Fabrication may be mapped to either Assembly or Central, depending on the user's preference for cost collection.

Manufacturing Transactions to Project Transaction Source Mapping

The following table provides a mapping between the transactions in Inventory and Work in Process to the Transaction Sources in Oracle Projects for these transactions:

Inventory and Work in Process Transaction	Transaction Source (Oracle Projects)
Inventory Transactions (for example, PO Receipt, Subinventory Transfer, WIP Issue, Misc. Issue, and so forth)	Inventory
Project Miscellaneous Transactions	Inventory Miscellaneous
Work in Process Transactions	Work in Process

Organization Costing Information

Inventory: Setup>Organizations>Parameters

If you check Project Cost Collection Enabled in the Project Information Region, you must choose Average as the costing method for the organization in the Costing Information Region of the Inventory Organization Parameter form. Checking Project Cost Collection enables the transfer of manufacturing costs to Oracle Projects. Otherwise, you can select either Average or Standard costing methods.

If the Average costing method is selected, you also enter an average rates cost type, which you define on the Cost: Stupidest Types form. The average rates cost type is a user-defined cost type that holds resource and overhead association, current overhead rates, and any other user-defined sub-element rates.

When you define a cost group for an organization, the accounts defined in the Organization Parameters form are defaulted but can be overwritten. Locators that reference projects that belong to a cost group use these accounts for inventory valuation. You therefore cannot change an account if there is on-hand inventory in any of these locators.

Setup Expenditure Types and Expenditure Type Classes

PA: Setup> Expenditures> Expenditure Types

Projects: Setup > Financial Accounting > Expenditure Types

An expenditure type is a classification of cost that you assign to an expenditure item you enter in Oracle Projects. You must setup expenditure types to associate with your manufacturing cost elements – material, material overhead, resource, resource overhead, and outside processing - and sub-elements, which are a more detailed level of cost elements, such as metals, plastics, assembly labor, welding labor, plant overhead, material management overhead. Expenditure types have four components:

- An expenditure category
- A revenue category
- A unit of measure
- An expenditure type class

Expenditure categories are used for grouping expenditure types for costing. Revenue Categories are used for grouping expenditure types for revenue and billing. Predefined expenditure type classes tell Oracle Projects how to process an expenditure type.

You need to link an expenditure type to cost elements and sub–elements so that Inventory and Work in Process transaction costs can be collected in Oracle Projects as expenditures.

Associating Expenditure Types to Multiple Expenditure Type Classes

PA: Setup> Expenditures> Expenditure Types

You can assign multiple expenditure type classes to an expenditure type. For example, an expenditure with the expenditure type Materials can have the expenditure type class Supplier Invoice if it originated in Oracle Payables, the expenditure type class Inventory if it originated in Oracle Inventory, and the

expenditure type class Usages if it originated in Oracle Projects. This example is illustrated below:

Expenditure Type	Expenditure Type Class	Module Where Expenditure Originated
Material	Supplier Invoice	Oracle Payables
Material	Inventory	Oracle Inventory
Material	Usages	Oracle Projects

This feature allows you to use a single expenditure type to classify as many different costs as you require. You can use the same expenditure type for expenditures that have different origins (and therefore different accounting), but which should otherwise be grouped together for costing, budgeting, or summarization purposes.

Linking Expenditure Types to Cost Elements

Projects: Setup> Financial Accounting> Expenditure Types for Cost Elements

CST: Setup> Expenditure Types for Cost Elements

Material receipts and resource charges to a WIP job are the only transactions that pass cost to Oracle Projects at the cost sub-element level. All other transactions pass cost at the cost element level (material, material overhead, resource, resource overhead, and outside processing). You must associate in and out expenditure types with each of the five cost elements so that costs will pass to Oracle Projects for transactions that occur at the cost element level.

See Also

Oracle Cost Management User's Guide

Setup Cost Sub-elements and Link to Expenditure Types

PJM: Setup>Financial Accounting>Sub-Element>Material, Resources, Overheads

CST: Setup> Sub-Element>Material, Resources, Overheads

Bill of Materials: Routings > Departments

You can setup multiple sub-elements for material, resources, and overhead. You need to link all material, resource, and overhead sub-elements to expenditure types in order to pass the costs to Oracle Projects.

Important: You should select a Default Material Sub-Element on the Costing Information Region of the Inventory Organization Parameters form. Setting up a Default Material Sub-Element will eliminate the need to associate every material item with a cost sub-element and will enable all project material receipt costs to pass to Oracle Projects.

You can associate your resource and overhead sub-elements to your manufacturing departments and assign rates in the Bills of Material Routings Department and Resources forms. Each resource can be set up to charge actual or standard costs. You can define production overheads based on the number of units or lot moved through the operation, or based on the number of resource units or value charged in the operation. You can also setup the GL account that will be credited for resource overhead absorption on this form.

Outside processing sub-elements represent service provided by suppliers. Each outside processing resource you define may be setup to charge actual or standard costs.

See Also

Oracle Cost Management User's Guide

Assign Material Overhead Rates to Items

Cost: Setup > Sub-elements > Defaults

Projects: Setup > Financial Accounting > Sub-Elements > Defaults

Important: If possible, setup your default material overhead rates before you setup your items because the default rates only apply to items which are subsequently defined after the default rates have been setup. Therefore, if you assign a default material overhead rate before you create items, the material overhead subelement and rate will default into the Average Rates Cost Type on the Item Cost Form when you define the items. Material overhead will be subsequently applied when the item is transacted, which in the case of buy items is at the point of receipt into inventory and for make items is at the point of issue out of the WIP job into finished goods inventory.

Inventory: Cost > Item Costs > Item Costs > Costs

If you have not setup default material overhead or you want to override it for particular items, you can associate your material and material overhead sub-elements to your material items and define material overhead rates for your Average Rates Cost Type on the Item Cost form. You can assign material overhead based on Item, Lot or Total Value basis. When you change the overhead rate for an item, the new rate will be applied to any transactions that occur after the time you made the change.

The Average Cost Type is predefined and does not have to be setup by the user. The Average Cost Type holds the current weighted average unit cost of items on-hand, and is used to value transactions such as issues and transfers out. You can update costs in this cost type only by using the average cost update routine.

Setup Project

PA: Project > Project

PJM: Project Definition > Project

You setup a project by copying the data from a template or another project. You can setup several templates for various project types depending on the information you want to flow down from your template to your project. When you copy a project from a template, the work breakdown structure and the following options associated with the project types will be copied from the template to the project:

- General information including the class of project as contract and the default service type to use when creating tasks
- Costing information for burdening non-manufacturing cost

- Budget controls for defaults and entry of budgets
- Billing information, including defaults for billing schedules and invoice formats
- Distribution rules for revenue recognition and billing method allowed for the project type

You can optionally copy agreements and funding, budgets, key members, resources lists, and any other project and task options from a project template. If you manufacture similar items with similar work breakdown structures and consequently, similar budgets, you can copy several projects from one template and make minor changes to the WBS, budget, etc., for each project copied from the template.

You should add a project classification category (such as PJM) to your project (template) if you plan to use Project Allocations to allocate cost from a manufacturing cost pool (GL balance) to designated Project Manufacturing projects. You can also use the classification category to identify Project Manufacturing projects for other reporting purposes.

See Also

Oracle Projects User's Guide

Setup Cost Groups

PJM: Setup>Financial Accounting>Sub Groups

CST: Setup> Cost Groups

Cost Groups enable you to calculate average cost for items that belong to the project or projects in the cost group. The same item can have different average costs for each cost group

in the same organization. You can define and subsequently use cost groups only if you use Average Costing.

The Inventory Valuation Accounts that you define on the Organization Parameters Costing Information Region form will populate your Cost Group accounts when you click on the first account field. These accounts are used in any transactions that debit or credit Inventory Asset Accounts, such as material receipts to inventory, miscellaneous transactions and project transfers, component issues to and returns from WIP, and completion of finished assemblies from WIP to finished goods. You may change the accounts for your cost group to any valid accounts.

Weighted average costs are perpetually calculated for each item within a cost group. If a cost group is valid in several inventory organizations, the averaging is performed within each organization, triggered by transactions which change the cost group cost, such as PO Receipts, Miscellaneous Receipts, or Project Transfers at costs which differ from the current cost group cost. If the cost group will have projects that are defined in multiple inventory organizations, it must be defined as a multi-org cost group.

You can assign one or more projects to a cost group on the Project Parameters form. The following table illustrates how you would setup the cost group in a Project Manufacturing environment depending on how you want to track item costs:

Objectives	Setup
Track item costs by project	Assign a unique Cost Group for each project
Track item costs by a group of projects	Assign a unique Cost Group to the group of projects
Track item costs by organization	Assign all the projects to the Common Cost Group

In order to simplify inventory reconciliation between Manufacturing and Oracle Projects, it is advisable to associate only one project to a cost group. If you assign multiple projects to a cost group, you can change the average cost of an item owned by one project by receipt of the same item at a different cost to another project in the cost group. The change in the average cost will not be visible in Oracle Projects, as illustrated by the following example, in which three projects belong to one cost group - CG-1:

Date	Owning Project	Item	Qty	Acquisition Cost	Average Cost in CG-1	Cost Transferred to Oracle Projects
Apr 1	P1	A	1	\$10	\$10	\$10
Apr 4	P2	A	1	\$12	\$11	\$12
Apr 9	P3	A	1	\$14	\$12	\$14

Month-End Reconciliation

Inventory has \$36 cost in one Cost Group under 3 locators:

- CG-1 has Qty 3 Item A @ \$12 = \$36

Oracle Projects has \$36 cost in 3 Projects:

- P1 has Qty 1 Item A @ \$10 = \$10

- P2 has Qty 1 Item A @ \$12 = \$12
- P3 has Qty 1 Item A @ \$14 = \$14

In order to reconcile your inventory costs to project cost held in Oracle Projects in the example above, you must total the item costs in three projects and compare the total to your cost group total. Assigning only one project to a cost group will simplify reconciliation of cost between Manufacturing and Oracle Projects.

See Also

Oracle Cost Management User's Guide

Setup WIP Accounting Classes

Projects: Setup>Financial Accounting>WIP Accounting Classes

WIP: Setup> WIP Accounting Classes

Link WIP Accounting Classes to Cost Groups in an Average Costing Organization

You can associate one or more WIP Accounting Classes to a Cost Group. You may want to use different WIP Accounting Classes for different types of projects. By assigning a project to a Cost Group and associating WIP Accounting Classes to a Cost Group, you can insure that the desired WIP Accounting Classes are used for the project.

Default WIP Accounting Classes for Item Categories

Cost: Setup > Account Assignments> Category Default WIP Classes

You can implement product line accounting by creating product line categories and associating them with product line category sets. You can assign a default WIP Accounting Class to Standard Discrete Jobs for Cost Group/Item Category combinations. The List of Values of WIP Accounting Classes on this form contains only those classes associated with the Cost Group.

See Also

Oracle Work in Process User's Guide

WIP Accounting Class Defaulting and Validation for Project Discrete Jobs

If you use Weighted Average Costing method for your organization, the following WIP Accounting Class defaulting and validation logic applies when a project job is created through MRP or manually:

1. The system checks the Default WIP Accounting Class for Categories first to find the WIP Accounting Class that is associated with the Cost Group that the project belongs to, and assigns it to the job.
2. If no valid combination of cost group and item category is found in the Default WIP Accounting Class for Categories table, the system uses the default WIP Accounting Class defined in Project Parameters.
3. If no data is found, the WIP Accounting Class will be left blank on the job form. The user must enter the WIP Accounting Class to save the job.

Validation Logic

The List of Values for WIP Accounting Class on the Discrete Job form only contains the WIP Accounting Classes associated with the cost group of the project for this job.

Common Project Assignment

You can optionally setup a common project to hold the cost of manufacturing transactions that have not been associated with a specific project. This will enable you to budget for common costs and view commitments, actual, and budgeted cost for your common project on the standard Project Status Inquiry.

You can setup a different common project for each inventory organization. You specify the common project number on the PJM Organization Parameters form (not the Project Parameters form). You can define one or more tasks for the common project on the Task Auto Assignment Rules form.

When you run the Cost Collector, the common project value assigned on the PJM Organization Parameters form is assigned to all transactions related to common items. Common project task(s) are derived from the Task Auto Assignment Rules.

Setup Planning Groups

PJM: Setup> Manufacturing> Planning Groups

MRP: Setup> Planning Group

You can use Planning Groups to group one or more projects that share supply. Projects within the same planning group can share supply, depending on the reservation level set in the plan level options.

With Planning Groups, MRP will reserve project specific supply for demand at a planning group level. A supply for one project can be reserved against a demand for another project, if both projects belong to the same planning group.

See Also

Oracle Master Scheduling/MRP and Oracle Supply Chain Planning User's Guide

Project References and Validation Logic

This chapter provides references to other relevant Oracle products and information about validations. The following topics are included:

- References to Other Oracle Products
- Project Manufacturing Validations

References to Other Oracle Products

Oracle Project Manufacturing enables you to enter project or project and task on various entities within Oracle Applications. The following table provides a list of these entities and cites the documentation where you find can detailed information.

Product	Form/Window, Region	Documentation Reference
PJM	Project Parameters	Assigning Project Parameters, <i>Oracle Project Manufacturing User's Guide</i>
APS	Planner Workbench	Planner Workbench/User Interface, <i>Oracle ASCP and Oracle GATP Server</i>
INV	Stock Locator	Defining Stock Locators, <i>Oracle Inventory User's Guide</i>
INV	Transaction Type	Defining and Updating Transaction Types, <i>Oracle Inventory User's Guide</i>
INV	Move Orders (Projects/Tasks tab)	<i>Oracle Inventory User's Guide</i>
INV	Transaction Move Orders	<i>Oracle Inventory User's Guide</i>
INV	Transaction Interface, Other alternative region	Viewing and Updating Transaction Open Interface Activity, <i>Oracle Inventory User's Guide</i>
MRP	Forecast Entries	Defining a Forecast, <i>Oracle Master Scheduling/MRP and Oracle Supply Chain Planning User's Guide</i>
MRP	MDS Entries	Defining Schedule Entries Manually, <i>Oracle Master Scheduling/MRP and Oracle Supply Chain Planning User's Guide</i>
MRP	MPS Entries	Defining Schedule Entries Manually, <i>Oracle Master Scheduling/MRP and Oracle Supply Chain Planning User's Guide</i>
MRP	MPS Workbench, Implement	Implementing Planned Orders, <i>Oracle Master Scheduling/MRP and Oracle Supply Chain Planning User's Guide</i>
ONT	Sales Orders, Project Sales Orders (Line Items tab), Project alternative region	Defining Sales Order Line Project Information, <i>Oracle Order Management</i>
ONT	Schedule, Schedule Sales Order), Project tab	Updating Lines to Schedule, <i>Oracle Order Management</i>
ONT	Sales Orders, Option Lines (Option) {Tools Menu>Show Line Details}	Choosing Options, <i>Oracle Order Management</i>

Product	Form/Window, Region	Documentation Reference
PO	Requisitions, Distribution (Distribution), Project alternative region	Entering Requisition Distributions, <i>Oracle Purchasing User's Guide</i>
PO	Requisitions, Preferences (Preferences), Project Information alternative region	Entering Requisition Preferences, <i>Oracle Purchasing User's Guide</i>
PO	Purchase Orders, Distribution (Distribution), Project alternative region)	Entering Purchase Order Distributions, <i>Oracle Purchasing User's Guide</i>
PO	Purchase Orders, Preferences (Preferences), Project Information alternative region	Entering Purchase Order Preferences, <i>Oracle Purchasing User's Guide</i>
PO	Releases, (Distribution), Project alternative region	Entering Release Distributions, <i>Oracle Purchasing User's Guide</i>
PO	Releases, Preferences	<i>Oracle Purchasing User's Guide</i>
PO	RFQ, More alternative region	Entering RFQ Lines, <i>Oracle Purchasing User's Guide</i>
PO	Quotations, More alternative region	Entering Quotation Lines, <i>Oracle Purchasing User's Guide</i>
QA	Collection Element, Plan	Collection Elements, <i>Oracle Quality User's Guide</i>
WIP	Discrete Job, Project alternative region	Defining Discrete Jobs Manually, <i>Oracle Work in Process User's Guide</i>
WIP	Pending Jobs and Schedules, Discrete region	Processing Pending Jobs and Schedules, <i>Oracle Work in Process User's Guide</i>
WIP	Work Order-less Completions	Performing Work Order-less Completions, <i>Oracle Work in Process User's Guide</i>
WSH	Release Sales Order	<i>Oracle Shipping Execution User's Guide</i>
WSH	Shipping Transactions (Lines and Containers tab)	<i>Oracle Shipping Execution User's Guide</i>

Project Manufacturing Validations

Common Validation

The system validates the project and task segments of a locator based on the value of the Project Control Level parameter you set up in Organization Parameter. The following table describes the validation logic:

Project Control Level	Project Segment	Task Segment
Null	Cannot enter any value.	Cannot enter any value.
Project	Optional.	If Project is entered, Task is optional. If Project is not entered, Task cannot be entered.
Task	Optional.	If Project is entered, Task is mandatory. If Project is not entered, Task cannot be entered.

Validations in Procurement

Purchase Order Delivery Transaction

When you perform a Purchase Order Delivery transaction for a project purchase order, the system defaults the project and task from the distribution line of the purchase order to the receiving locator.

If you define Item Transaction Defaults for receiving locators for specific items in Inventory set up (provided these are physical locators), the system concatenates the default locator with the project and task references from the purchase order distribution line when it is received into its inventory destination.

If you update the project and task on the receiving locator, they are validated against, and must exactly match, the project and task on the distribution line of the purchase order.

Purchase Order Return Transaction

When you perform a Purchase Order Return transaction, the system defaults the project and task from the purchase order distribution line to the from locator.

If you update the project and task segments of the from locator on a purchase order return, they are validated against, and must exactly match, the project and task on the purchase order distribution line.

Purchase Order Adjustment Transaction When you perform a Purchase Order Adjustment transaction, the system defaults the project and task from the purchase order distribution line to the locator.

If you update the project and task segments of the locator on a purchase order adjustment, they are validated against and must exactly match the project and task on the purchase order distribution line.

Note: You can not use a project locator for all the above transactions if the purchase order distribution does not have project and task.

Validations in Inventory

The system applies the Common Validation logic to the following transactions:

- Miscellaneous Issue
- Miscellaneous Receipt
- Subinventory Transfer
- Locator Transfer
- Interorganization Transfer (Direct)
- Internal Order Interorganization Transfer (Intransit)
- Cycle Count Adjustment
- Physical Count Adjustment

Validations in WIP

Project Discrete Job Completion Locator When you create a project discrete job (either manually or from the Planner Workbench), the system defaults the project and task from the project discrete job to the project and task segments of the completion locator. If you have assigned a completion locator (common locator) to the routing, the system concatenates the common locator segments with the project and task to create a project locator.

When you update the project and task on the Project Discrete Job, the system re-defaults the project and task segments of the Completion Locator.

If you update the project and task segments of the Completion Locator, they are validated against and must exactly match the project and task on the Project Discrete Job header. They cannot be null.

Project Discrete Job Completion Transaction

When you perform a Completion Transaction, the system defaults the Completion Locator from the Project Discrete Job header.

If you update the project and task segments of the Completion Locator, they are validated against and must exactly match the project and task on the Project Discrete Job header. They cannot be null.

Project Discrete Job Material Requirements

When you define a project discrete job for an item that has a bill of material, the bill is copied to the project discrete job. If the components are *hard pegged* (their pegging attribute is set to either Hard Pegging or End Assembly/Hard Pegging), then the system defaults the project and task from the project discrete job header to their supply locator. If you have assigned supply locators (common locator) on the bills of material, the system concatenates the supply locators with the project and task to create a project locator.

If you update the project and task on the project discrete job, the system re-defaults the project and task segments of any hard pegged components.

If you update the project and task segments of the supply locator for any components of a project discrete job, they are validated against and must either match the project and task on the project discrete job or be null.

If the components are *soft pegged*, (their pegging attribute is set to either Soft Pegging or End Assembly/Soft Pegging) the system does not default the project and task segments to the supply locators. You can optionally override this and assign the project and task to the supply locator. The system validates the project and task against the project and task from the project discrete job header.

Project Discrete Job Component Issue Transaction

The system validates the supply locator for a Component Issue Transaction for a project discrete job. The supply locator must satisfy one of the following criteria:

- No project/task reference on the supply locator.
- The project and task on the supply locator must exactly match the project and task on the project discrete job.

- Same project but different task, if the parameter *PJM: Allow Cross Project Issues* is set to Yes.
- A different project with the same cost group and planning group association as the project on the project discrete job. The parameter *PJM: Allow Cross Project Issues* is set to Yes.

Project Discrete Job Return Assembly to WIP Transaction

If you enter or update the project and task segments of the completion locator on a Return Assembly to WIP Transaction, they are validated against and must exactly match, the project and task on the project discrete job.

Project Discrete Job Component Return Transaction

If you enter or update the project and task segments of the supply locator on a Component Return, they are validated and must satisfy one of the following criteria:

- No project/task reference on the supply locator.
- The project and task on the supply locator must exactly match the project and task on the project discrete job.
- Same project but different task, if the profile *PJM: Allow Cross Project Issues* is set to Yes.
- A different project with the same cost group and planning group association as the project on the project discrete job. The profile *PJM: Allow Cross Project Issues* is set to Yes.

Project Work Order-less Completion

When you perform a project work order-less completion, you must specify the assembly, quantity, project or project and task, and other information. If you have set up a default completion locator on the routing, the system defaults it in for the transaction. If you have not set up a default completion locator, you can specify one for the transaction. When the transaction is saved, the system defaults the project and task from the transaction to the completion locator.

Work order-less completion automatically backflushes all operation pull, assembly pull, and push components. The system builds the supply locators for the components by concatenating the supply locator from the item and the project or project and task you specify.

Note: You can not use a project locator as completion locator or supply locator for all the above transactions against a non-project (common) discrete job.

Validations in Shipping

Pick Release When you perform Pick Release for a project sales order, the system ensures that you can only pick release from the project locators that have the same project and task as the sales order line.

Project Definition

This chapter describes how to associate a project number or a seiban number with a Planning Group, a Cost Group, and a Default WIP Accounting Class. The following topics are included:

- Defining Project Parameters
- Seiban Number Wizard

Defining Project Parameters

►► To set up project parameters:

1. Navigate to the Project Parameters window.
2. If you are making the first assignment, enter the project or seiban number you want to associate with a planning group. If you are updating an existing assignment, query the existing record and make the necessary changes.

If the number you enter is a seiban number, the Seiban Number flag is automatically enabled.

3. Select a Cost Group.

If the organization has selected Standard as its primary costing method in the Organization Parameters window, the Cost Group field is disabled. Standard Costing is available only when you do not use cost collection from manufacturing to Oracle Projects. Standard Costing does not require cost groups.

If the organization has selected Average as its primary costing method in the Organization Parameters window, the Cost Group field is enabled. You must select a Cost Group from the list of valid Cost Groups for a project in an average costing organization. The list of values includes the Common Cost Group and the user defined cost groups. The list of user defined cost group includes only those cost groups with valid accounts in the Cost Group form. Please refer to the Costing User Guide for details on Cost Group definition. Weighted average costing for Inventory and WIP is maintained at the Cost Group level. Therefore, if you want to keep weighted average costing at the project level, you must assign the project to its own Cost Group.

4. Optionally, enter a WIP accounting class.

If the organization has selected Standard as its primary costing method in the Organization Parameters window, the WIP accounting class will be Standard Discrete.

If the organization has selected Average as its primary costing method in the Organization Parameters window, you can choose any WIP accounting class that has been associated with the selected cost group in the WIP Accounting Classes for Cost Groups window in Cost Management.

When you create project jobs or complete work order-less schedules for a project, this accounting class is defaulted if an accounting class, based on the assembly item's category set, cannot be found. It can be overridden, but only

with another accounting class that is assigned to the cost group. See WIP Accounting Class Defaults:, *Oracle Work in Process User's Guide*.

Note: When you create a project WIP job either manually or through MRP, the system checks whether you've assigned a default WIP accounting class to this WIP job's item category and cost group in the Default WIP Accounting Classes for Categories window. If you have, the program uses this WIP accounting class for the job. If you have not, the program uses the WIP accounting class you entered for the project.

5. Optionally, select the name of the planning group with which you want to associate your project or seiban number.

If you plan material requirements by a group of projects, rather than by each individual project, you need to define a planning group and to assign all the projects to this planning group. If you plan net material requirements only by a single project, you do not need to associate the project with any planning group.

For more information about planning groups, see Defining Planning Group QuickCodes, *Oracle Master Scheduling/MRP and Oracle Supply Chain Planning User's Guide*.

6. Choose the Invoice Transfer tab.
7. Enter an expenditure type for IPV.

This field is mandatory in a Project Manufacturing organization, if the *Transfer to PA IPV* option has been selected on the Organization Parameters form. You can use the IPV expenditure type that has defaulted from the PJM Org Parameter form or modify it to choose any one of expenditure types that has been associated with expenditure type class Inventory. See: Defining Expenditure types, *Oracle Projects User's Guide*.

If an Invoice Price Variance is generated when approving an inventory or shopfloor (outside processing) related invoice, the Invoice Charge transfer process will use the IPV expenditure type defined in the Project Parameters window along with the IPV amount, IPV account, and Expenditure Organization to transfer the IPV amount for the project to Oracle Projects.

8. Enter an expenditure type for ERV.

This field is mandatory in a Project Manufacturing organization, if the *Transfer to PA ERV* option has been selected on the Organization Parameters form. You

can use the ERV expenditure type that has defaulted from the PJM Org Parameter form or modify it to choose any one of expenditure types that has been associated with the expenditure type class Inventory. See: Defining Expenditure types, *Oracle Projects User's Guide*.

If an Exchange Rate Variance is generated when approving an inventory or shopfloor (outside processing) related invoice, the ERV transfer process will use the ERV expenditure type defined in the Project Parameters window along with the ERV amount, ERV account, and Expenditure Organization to transfer the ERV amount for the project to Oracle Projects.

9. Enter an expenditure type for Freight.

This field is mandatory in a Project Manufacturing organization, if the *Transfer to PA Freight* option has been selected on the Organization Parameters form. You can use the Freight expenditure type that has defaulted from the PJM Org Parameter form or modify it to choose any one of expenditure types that has been associated with the expenditure type class Inventory. See: Defining Expenditure types, *Oracle Projects User's Guide*.

If you use receipt based matching for your invoice, and freight is entered on the distribution when approving an inventor or shopfloor (outside processing) related invoice, the invoice charge transfer process will use the freight expenditure type defined in the Project Parameters window It will also use the freight amount and freight account from Oracle Payables, and the expenditure organization from the purchase order to transfer the freight amount for the project to Oracle Projects.

10. Enter an expenditure type for Tax.

This field is mandatory in a Project Manufacturing organization, if the *Transfer to PA Tax* option has been selected on the Organization Parameters form. You can use the tax expenditure type that has defaulted from the PJM Org Parameter form or modify it to choose any one of expenditure types that has been associated with the expenditure type class Inventory. See: Defining Expenditure types, *Oracle Projects User's Guide*.

The method you choose to match tax to your invoiced items determines which expenditure type is assigned to the tax you enter on the Payables invoice. You can allocate tax at the line match level or you can enter tax as an invoice distribution line and manually allocate it to item distributions.

If you allocate tax at the match to line level as described below, tax entered on the invoice will be charged to the IPV expenditure type:

-
- You can select the option of matching the supplier invoice to the purchase order or purchase order receipt on the shipments form of the purchase order. When you enter the Payables invoice, you select the same matching method that you chose on the purchase order.
 - On the Match to Purchase Order form of Invoice Entry, you can check the Allocate checkbox next to each matching line to allocate tax, freight, and miscellaneous charges to the matched lines.
 - Tax matched to a purchase order or receipt line on this form is designated as an invoice price variance - the difference between the tax amount allocated on the invoice and the tax entered on the purchase order line. In Oracle Projects you will see the Invoice Price Variance expenditure type on the transaction for tax allocated on the invoice.

If you allocate tax at the invoice distribution line level as described below, tax entered on the invoice will be charged to the tax expenditure type:

- You can select the same matching method on the invoice as you selected on the purchase order as described above and perform matching to lines, but do not check the Allocate checkbox.
- You can enter a new distribution line for tax on the Invoice Distributions form and hit the Allocate button.
- You can manually allocate the tax to any of the item distribution lines.
- Tax matched on this form is designated as a tax (not invoice price variance) and is charged to the tax expenditure type which you set up on the Project Parameters form.

11. Enter an expenditure type for Miscellaneous charge.

This field is mandatory in a Project Manufacturing organization, if the *Transfer to PA Miscellaneous* option has been selected on the Organization Parameters form. You can use the Miscellaneous expenditure type that has defaulted from the PJM Org Parameter form or modify it to choose any one of expenditure types that has been associated with the expenditure type class Inventory. See: *Defining Expenditure types, Oracle Projects User's Guide*.

If a distribution is generated for Tax when performing receipt based matching for an inventory or shopfloor (outside processing) related invoice, the Invoice Charge transfer process will use the ERV expenditure type defined in the Project Parameters window along with the miscellaneous amount and account from invoice distributions and expenditure organization from the purchase order to transfer the miscellaneous charge for the project to Oracle Projects.

Seiban Number Wizard

The Seiban Number Wizard allows you to define seiban numbers and to create and modify projects using with top-level task structures only. For example, this is used for project creation in Lot Type Seiban environments.

Defining Seiban Numbers

►► To define seiban numbers:

1. Navigate to the Seiban Number Wizard.
2. Select Using Seiban Number.
3. Choose the Next button. The Seiban Numbers window will display, and you will no longer be in the Seiban Number Wizard.
4. Enter a seiban number and name unique within an Operating Unit. Alternatively, query any existing seiban numbers and choose New; then enter a seiban number and name.
5. Optionally, choose Parameters to navigate to the Project Parameters window.
This will automatically save your new seiban number and name. If you do not choose Parameters, save your work.
6. In the Project Parameters window, select the Organization. The LOV shows only organizations that have project level control.
7. Optionally, select values for the following fields:
 - Cost Group - Select when using Average as your costing method.
 - WIP Accounting Class
 - Planning Group
8. Save your work.

Creating a Project with Lot Type Seiban Numbers

You can use the new project and tasks in Oracle Projects and Oracle Project Manufacturing. You can use the Seiban Number Wizard to generate a project structure with only top-level tasks. This is typically used in a lot-type seiban environment but is also usable in a non -seiban environment.

All conditions related to Oracle Projects integration apply.

Prerequisite

- Define a project template. See: *Creating a Project Template, Oracle Projects User's Guide*

►► To define a project with lot type seiban numbers:

1. Navigate to the Seiban Number Wizard.
2. Select Using Project Number.
3. Choose the Next button. The Seiban Number Wizard Step 2 of 5: Project Option window will display.
4. Choose the Create a New Project option.
5. Choose the Next button. The Seiban Number Wizard Step 3 of 5: Project Option window will display.
6. Select the Template.
7. Enter the following information:
 - Project Number
 - Project Name
 - Start Date (for project)
 - Completion Date (for project)
8. Optionally, select the Submit Approval Window. Choose the Next button. The Seiban Number Wizard Step 4 of 5: Task Information window will display.
9. Enter the following information:

Parameter	Meaning	Example
Prefix (optional)	All tasks generated by the Wizard will begin with this value.	T
Suffix (optional)	All tasks generated by the Wizard will end with this value	-X
Starting Number	This will be the first task generated.	1
Ending Number	This is the last task that could be generated. The actual ending task number will be dependent on the increment parameter selected by the user.	1000

Parameter	Meaning	Example
Increment by	The task numbers generated will be incremented by this value.	If this value is 5 then the tasks would be 1,6,11 and so on.
Numeric Width (optional)	This value will cause leading zeros to appear before the task number, ensuring a fixed length for the task numbers. If you do not specify a value, there will be no leading zeros.	If this value is 4 then the tasks listed above would be 0001, 0006, 0011, and so on.

The lists of tasks generated in this example would be T0001-X, T0006-X, T0011-X and so on.

10. Choose the Next button. The Seiban Number Wizard Step 4 of 5: Task Information window will display.

11. Enter the following information:

Parameter	Meaning	Example
Prefix (optional)	All tasks generated by the Wizard will begin with this value.	T
Suffix (optional)	All tasks generated by the Wizard will end with this value	-X
Starting Number	This will be the first task generated.	1
Ending Number	This is the last task that could be generated. The actual ending task number will be dependent on the increment parameter selected by the user.	1000
Increment by	The task numbers generated will be incremented by this value.	If this value is 5 then the tasks would be 1,6,11 and so on.
Numeric Width (optional)	This value will cause leading zeros to appear before the task number, ensuring a fixed length for the task numbers. If you do not specify a value, there will be no leading zeros.	If this value is 4 then the tasks listed above would be 0001, 0006, 0011, and so on.

The lists of tasks generated in this example would be T0001-X, T0006-X, T0011-X and so on.

Modify an Existing Project with Lot Type Seiban Numbers

► To modify a project with lot type seiban numbers

1. Navigate to the Seiban Number Wizard.
2. Select Using Project Number.
3. Choose the Next button. The Seiban Number Wizard Step 2 of 5: Project Option window will display.
4. Choose the Add to an existing project option.
5. Choose the Next button. The Seiban Number Wizard Step 3 of 5: Project Selection window will display.
6. Select the Project Number.
7. Choose the Next button. The Seiban Number Wizard Step 4 of 5: Task Information window will display.
8. Enter the following information:

Parameter	Meaning	Example
Prefix (optional)	All tasks generated by the Wizard will begin with this value.	T
Suffix (optional)	All tasks generated by the Wizard will end with this value	-X
Starting Number	This will be the first task generated.	1
Ending Number	This is the last task that could be generated. The actual ending task number will be dependent on the increment parameter selected by the user.	1000
Increment by	The task numbers generated will be incremented by this value.	If this value is 5 then the tasks would be 1,6,11 and so on.

Parameter	Meaning	Example
Numeric Width (optional)	This value will cause leading zeros to appear before the task number, ensuring a fixed length for the task numbers. If you do not specify a value, there will be no leading zeros.	If this value is 4 then the tasks listed above would be 0001, 0006, 0011, and so on.

The lists of tasks generated in this example would be T0001-X, T0006-X, T0011-X and so on.

9. Choose the Next button. The Seiban Number Wizard Step 5 of 5: Confirmation will display.
10. Choose the Finish button.

Task AutoAssignment

This chapter explains the use of Oracle Project Manufacturing's Task AutoAssignment feature. Task AutoAssignment gives you a flexible way to specify how to track material and resource costs by tasks within your project rather than manually specifying tasks on your manufacturing transactions. Task AutoAssignment dynamically assigns tasks to manufacturing transactions based on user defined task assignment rules. The following topics are included:

- Overview
- Benefits
- Examples
- Implementation Procedures
- Implementation Notes

Figure 5-1
Task AutoAssignment - Schematic diagram

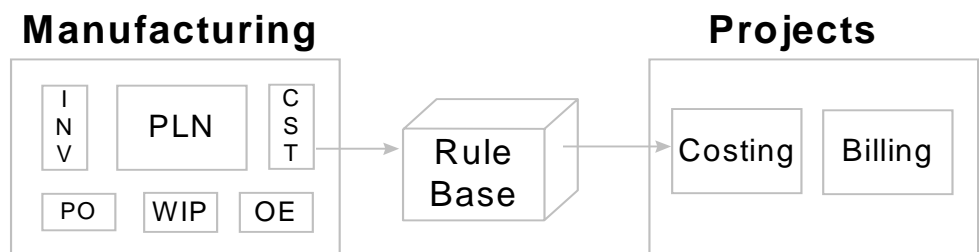

Overview

The Task AutoAssignment feature in Oracle Project Manufacturing (PJM) allows the user to specify a set of rules for assigning tasks to project material and resource transactions.

Currently this feature provides different criteria for creating the user defined rules. These are:

Material task assignment criteria:

- Item Number
- Procure Flag
- Purchase Order Number
- Category Code
- Subinventory

Resource task assignment criteria:

- Operation Code
- Job Number or Job prefix
- Assembly
- Department

For a given project, the user can use any combination of the above mentioned criteria to define a rule for a particular task.

Whenever a project related material or resource transaction is recorded, Task AutoAssignment compares the conditions for that transaction with the pre-specified rules for the project and automatically assigns the task. For example, a user who wants to monitor the usage of certain critical raw material for a project will define a rule that links a task to that material(item number). Wherever a transaction for this material occurs, it will be charged to that task.

A similar rule on the resource side would assign a critical operation to a separate task in the project WBS.

The following sections explain how to use this feature, the benefits of the Task AutoAssignment feature and illustrate some examples where this feature could be effectively deployed.

Material Task Assignment

PJM Menu : Project Definition> Task AutoAssignment> Assignment Rules
<Material>

The Material tab region of the Task AutoAssignment form lets you associate a task with an Item, Procure Flag, PO number, Item Category, and Subinventory. Task AutoAssignment looks at the item, whether the item is procured, or the PO number, category, and subinventory of a material transaction and finds a rule that matches the transaction. It then assigns a task to the transaction.

If more than one rule matches the values of some of these fields, Task AutoAssignment looks for the rule that corresponds to the highest-priority field, which is the field that appears on the left. For example, suppose you've defined two rules for Project P1:

Project	Task	Item	Procure	PO Number	Category	Subinventory
P1	T1	A		101		
P1	T2	A				Stores

When you deliver PO#101 for item A into Stores, Task AutoAssignment matches the transaction with the first rule (and therefore assigns task T1 to the transaction). The reason it picks the first rule rather than the second, even though both contain matching fields, is because the PO number has a higher priority than Subinventory which is displayed on the left of the Subinventory column on the form.

The users can also define the priority of these fields. For more information, refer to the section on Defining the hierarchy of Task Assignment Criteria.

See Also

Oracle Project Manufacturing User's Guide.

Resource Task Assignment

PJM Menu : Project Definition> Task AutoAssignment> Assignment Rules
<Resource>

The Resource tab region of the Task AutoAssignment form lets you associate a task with an Operation Code, Job (or Job Prefix), Assembly, and Department. Task AutoAssignment looks at the values entered in these fields and finds a rule that matches a resource transaction. It then assigns the task to the transaction.

If more than one rule matches the values of some of these fields, Task AutoAssignment looks for the rule that corresponds to the highest-priority field, which is the field that appears on the left. For example, suppose you've defined two rules for Project P1:

Project	Task	Operation Code	Job Number/ Prefix	Assembly	Department Code
P1	T1	Assembly	R%		
P1	T2	Assembly			AS2

When you perform a resource transaction for job R222 for a resource belonging to AS2 department, Task AutoAssignment matches the transaction with the first rule (and therefore assigns task T1 to the transaction). The reason it picks the first rule rather than the second, even though both contain matching fields, is that Job Number has a higher priority than Department Code which is displayed on the left of the Department Code column on the form.

The users can define the priority of these fields to suit their needs. For more information, refer to the section on Defining the hierarchy of Task Assignment Criteria.

See Also

Oracle Project Manufacturing User's Guide.

Defining the hierarchy of Task Assignment Criteria

PJM Menu : Project Definition> Task AutoAssignment> Flexsequence <Material>

or

PJM Menu : Project Definition> Task AutoAssignment> Flexsequence <Resource>

Users can change the hierarchy of the task assignment criteria if the default hierarchy does not meet their requirements. The task assignment forms will be regenerated using the user specified hierarchy. The criteria with higher priority will appear to the left of the ones with a lower priority.

Task AutoAssignment Program

Task AutoAssignment is intended to provide a flexible way for the users to determine how they want to track the material (inventory) and resource (WIP) costs by different tasks. It lets you define rules to associate different tasks for inventory and WIP transactions. When the inventory and WIP transactions are being costed

in the Oracle Inventory and WIP , the Task AutoAssignment assigns a task to the transaction based on the user defined rule(s). When the transaction cost is transferred to Oracle Projects, the cost is collected under the desired task.

The following process diagram shows the Cost Collection flow of a transaction through the Cost Worker and Cost Collector.

Figure 5–2 Process diagram for Task AutoAssignment

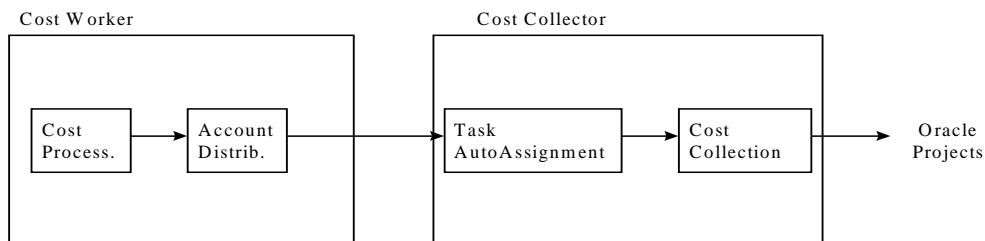

Benefits

The Task AutoAssignment feature provides the users with greater control over how project work breakdown structures are linked to manufacturing activities. Some of the key benefits are listed here:

1. Provides complete flexibility in defining Project WBS

Consider a simple Bill of Material (Figure 5-3) that is intended to be manufactured as a project.

Figure 5–3 Bill of Material for a project item

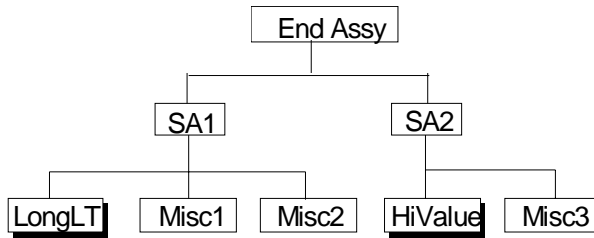

In order to achieve better cost control, it is identified that costs of items LongLT (a long lead time item) and item HiValue (expensive item) need to closely monitored. It is also necessary to track the costs of critical welding and prefabrication resources used in building the end assembly. In order to meet these objectives, a Project Work Breakdown Structure (WBS) is prepared that tracks these costs under separate tasks. The WBS is shown in Figure 5-4.

Figure 5–4 Proposed Project WBS

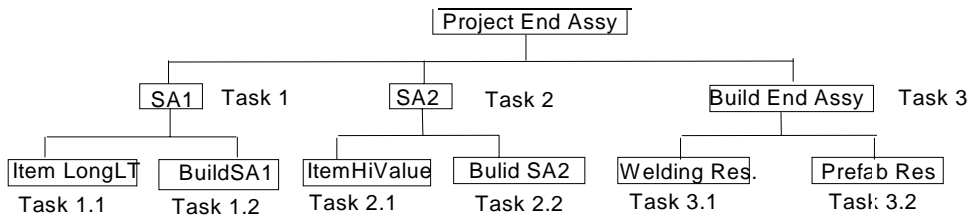

Without the Task AutoAssignment feature, it would not be possible to support such a project WBS. This is because the task number for manufacturing activities (Requisitions/Purchase Orders and WIP jobs) would have been either:

- Suggested by the planning system (using Project MRP), or
- Manually entered by the user.

In either case, the procurement and assembly activities of all the component items would have the same task as their parent. (Figure 5-5) As a consequence, all the

material and resource costs would be bundled up under one task and it would not be possible to monitor the costs of critical items and resources used in the project.

Figure 5–5 Task Assignment without Task AutoAssignment

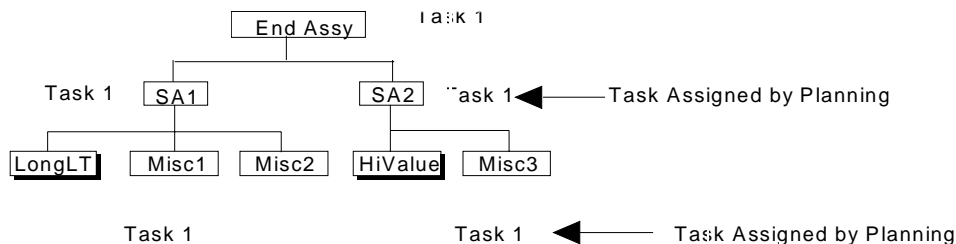

For example, if Task 1 is assigned to the end assembly on a MDS (or MPS or Forecast), the same task would appear on all the transactions for items HiValue and LongLT and also on all the resource transactions required in building the end item.

With the Task AutoAssignment feature, the user has a greater flexibility in designing the WBS. Apart from separating the costs of items LongLT and HiValue under different tasks, the usage of critical welding resources(Task 3.1) and prefabrication resources(Task 3.2) can also be tracked. This is accomplished automatically and hence consistently for a given project.

It is evident from the example that task assignment with the Task AutoAssignment feature is not restricted by (and to) the product structure. The user has the option of defining the WBS the way manufacturing activities are undertaken. This provides users with unlimited flexibility in defining their work breakdown structures.

2. Allows cost collection on a much finer level

Task AutoAssignment enables cost collection at a much finer level. Without Task AutoAssignment, task assignment (and hence cost collection) can happen only at the work order level. ALL the resource costs are charged to the task specified on the work order. With Task AutoAssignment, cost collection can be pushed down to the department level or even to individual operation level. A comparison of the standard functionality and the *additional* functionality imparted by Task AutoAssignment is shown below.

Figure 5–6 Cost Collection without Task AutoAssignment

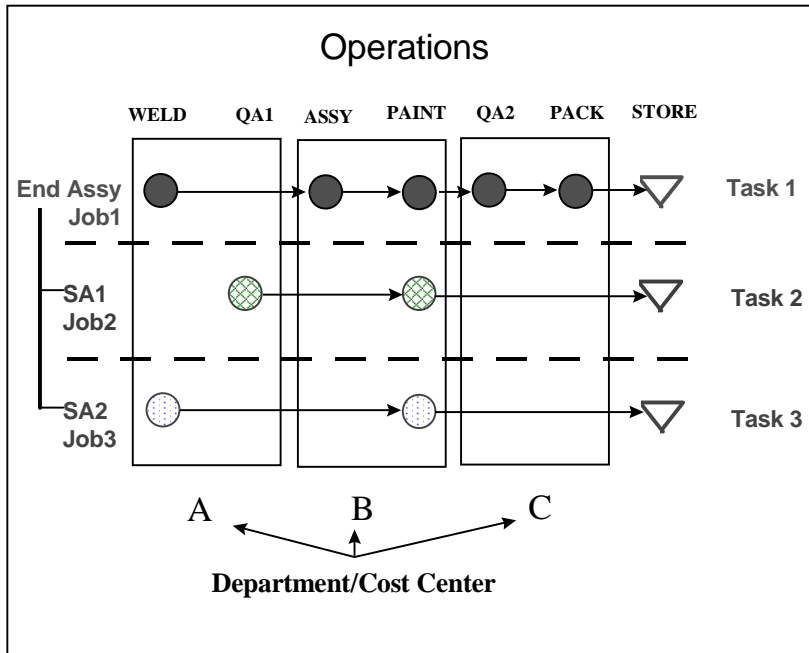
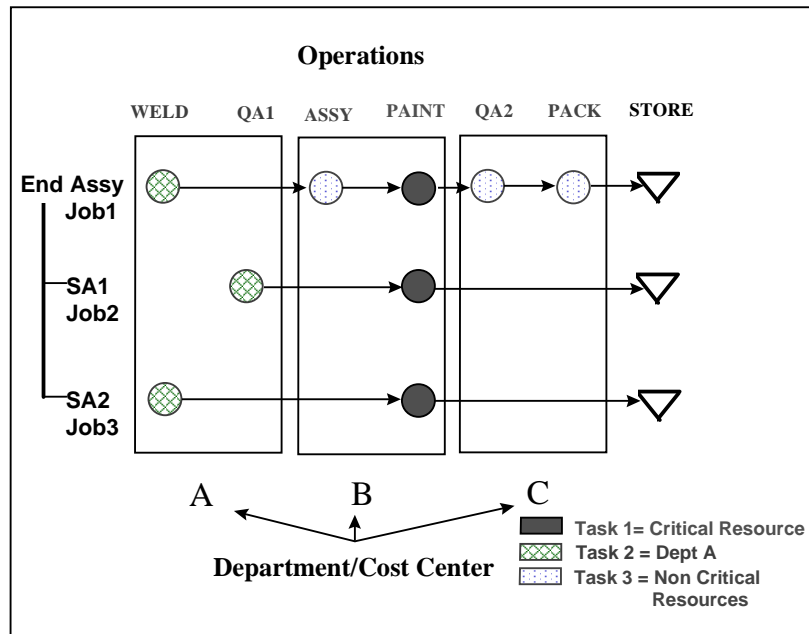

Figure 5–7 Cost Collection with Task AutoAssignment



As indicated in Figure 5-7, Task AutoAssignment will give the user considerable flexibility in cost collection. You can choose the granularity of cost collection based on the specific requirements.

3. Eliminates manual task entry

In spite of adding so much flexibility and increasing the granularity of cost collection, the user is completely oblivious to the task assignment process. You do not worry about entering tasks on any project related transactions (Inventory/Purchasing/WIP). This eliminates all the errors associated with manual task entry.

Cost accountants can now control the allocation of manufacturing costs to a project instead of manufacturing personnel assigning tasks to a transaction.

The user can still choose to manually enter a task for any of the transactions. This task will not be overridden by Task AutoAssignment.

Users will have to plan, execute and track manufacturing activities at a project level instead of a more granular task level if Task AutoAssignment is used.

4. Enables Standardization of Project WBS and Manufacturing Costing

The task assignment rules for material and resource transactions guide the process of task assignment. Once the rules have been defined, the process of task assignment takes place with no human intervention. This facilitates creation and maintenance of organization-wide standards for defining Project WBS and manufacturing cost collection. This is an added advantage over all the other benefits mentioned earlier.

Examples

This section briefly describes some typical examples using the Task AutoAssignment feature. The given list is just an indicator of things that could be accomplished with the Task AutoAssignment feature.

1. Budget and Track critical resource consumption for a project

On many occasions it is necessary to budget and closely monitor the usage of a critical manufacturing resource for a project. This could be a resource using expensive piece of machinery or a resource with unstable process/high rejection rates or a resource that uses highly skilled manual labor. The Task AutoAssignment feature allows the user to budget for and monitor these critical resources by project.

This will ensure better visibility of critical or money losing resource costs and enable better control over such resources.

2. Collect costs by department

Using Task AutoAssignment, costs can also be collected by the manufacturing departments involved. All the resource consumption in a particular department for the project will always be charged to a user-specified task. This enables budgeting for projects by the individual departments involved. Simultaneously, it also enables project progress monitoring/performance evaluation by department.

The following figures show two different approaches in which you could setup Project Work Breakdown Structure in relation to the Organization Breakdown Structure. Without Task AutoAssignment, such a link between Project Work Breakdown Structure and Organization Structure would not be possible for manufacturing departments.

Figure 5–8 Inventory Organizations as Project Expenditure Organizations

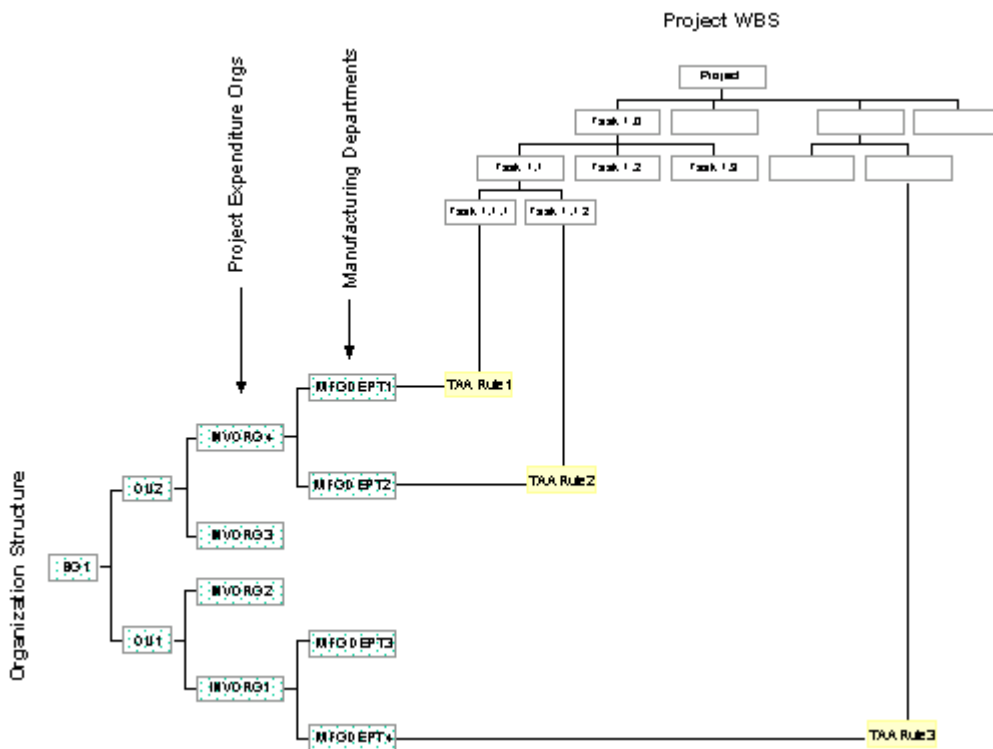
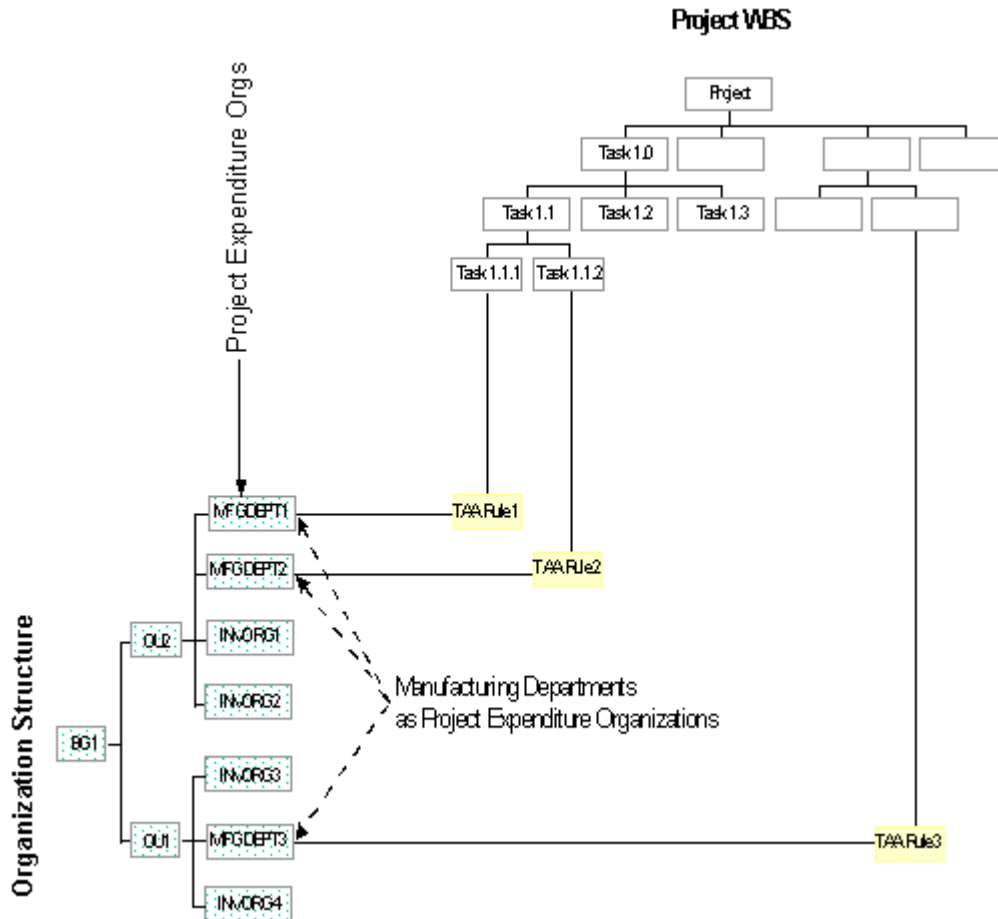

Figure 5-8 shows an example where Inventory Organizations (INVORG1, INVORG2, etc.) have been modeled as Project Expenditure Organizations.

These Expenditure Organizations have been referenced on the Manufacturing departments. For example, MFGDEPT1 and MFGDEPT2 have been assigned the same Project Expenditure Organization INVORG1. Task AutoAssignment rules (TAA Rule1, TAA Rule2, etc.) have been setup such that resource costs incurred in each of the manufacturing departments are collected under a separate task. The disadvantage of this approach is that we lose visibility of manufacturing department level costs in a Project Expenditure Organization. i.e. Costs in Project Expenditure Organization INVORG1 will commingle the resource costs for MFGDEPT1, and MFGDEPT2 along with other expenditures (including material costs) for INVORG1.

Another approach shown in figure 8 models manufacturing departments as individual Project Expenditure Organizations. Here each Manufacturing Department represents one Project Expenditure Organization and there is no commingling of costs.

Figure 5–9 Manufacturing departments as Project Expenditure Organizations



3. Collect resource costs for a particular job/assembly

Another application of the Task AutoAssignment feature is seen in a case where the user intends to monitor the resource usage for a particular assembly or a particular WIP job. The user can assign a task assignment rule for this assembly or WIP job and can monitor the resource usage for that assembly or WIP job. If there is a need to control a specific resource for a job or an assembly, it can also be accomplished using Task AutoAssignment. Users can associate only unreleased jobs with a resource task assignment rule.

4. Collect resource costs for a specific group of WIP jobs

Users can generate jobs in Oracle Work In Process with a particular prefix. Task AutoAssignment allows you to define resource task assignment rules with partial WIP job numbers as one of the criteria. This will enable monitoring resource usage for a specific group of jobs that carry a certain prefix. This will enable grouping of project costs for a specific work (e.g. rework, repair, etc.) under separate tasks automatically.

Note: Users can choose to enter any number of characters before entering the wildcard character (%). For example, if RW is the chosen prefix for rework type jobs, the users can enter R% or RW% or RW100% as the task assignment criteria to refer to a specific group of jobs. The rule will then apply to a broader or narrower group of WIP jobs.

5. Track procurement activity

A task assignment rule that uses Procure Flag as one of its conditions facilitates tracking of the procurement activity. When purchased material is received for a project, the value of the receipt (plus any applicable overheads) are charged to the task that corresponds to the rule. This helps to monitor the progress of project procurement activities. This can be used for monitoring procurement of project items that have a very long lead time or are very expensive.

Tracking of procurement against a specific purchase order is accomplished by entering the PO Number as one of the task assignment criteria or by entering the task directly on the PO distribution line.

You cannot enter partially received purchase orders as task assignment criteria.

6. Track cost of critical items for a given project

A task assignment rule that uses an item number as one of the criterion (with the PO field blank and the procure flag unchecked) can be used to track the cost of that

item for a given project. This set of rules will keep a track of all the inventory transactions for that item and will keep an account of the value of material consumption for the project.

Implementation Procedure

Set Project Control Level = Project Set the Project Control Level organization parameter to Project. This enables you to have project-only identity to supply and demand orders. You can then use Task AutoAssignment to assign task for the transactions. Project Cost Collection should be enabled.

Define the hierarchy of material and resource Task Assignment criteria You need to define the hierarchy of material and resource task assignment criteria. Users should ensure adequate security for this form.

Define the WIP job prefix (optional) Define the profile option in WIP to generate WIP jobs with a certain prefix. This step is optional.

Create Project Work Breakdown Structure (WBS) You need to determine how you want to budget and track your project expenditures first. Then you create the WBS for your project.

Setup Project Parameters You need to assign your project to a cost group, a default WIP accounting class, optionally a planning group, a default material task and a default resource task in the Project Parameter form. The form automatically creates a default material task assignment rule in the Material Assignment table using the default material task, and a default resource task assignment rule in the Resource Assignment table using the default resource task you specify in this window.

Enter Material Task Assignment Rules Enter your task assignment rule(s) in the Material tab region of the Task AutoAssignment form. You should make sure that you enter all the rules before you start transactions.

If the user desires to use PO number(s) as a part of the task assignment rule(s), the corresponding purchase order(s) has to be created before it could be entered in this form.

Enter Resource Task Assignment Rules Enter your task assignment rule(s) in the Resource tab region of the Task AutoAssignment form. You should make sure that you enter all the rules before you start transactions.

Note: If the user desires to use WIP Job number as a part of the task assignment rule(s), the corresponding WIP job has to be created before it could be entered in this form.

Implementation Notes

The Task AutoAssignment feature brings a lot of flexibility in defining Project WBS and collection of manufacturing costs. Given below are some key aspects that the users should be aware of while using the Task AutoAssignment feature.

1. Coverage of the entire spectrum of Material and Resource Transactions is essential

While defining the task assignment rules for a project, it is necessary that all conceivable material and resource transactions are accounted for. If this condition is not satisfied, some transactions would not be assigned the desired task and the costs for such transactions would be transferred to the project on the default task.

A default task assignment rule is a rule that has the project and task fields populated and all the other task assignment criteria are null. You define the default tasks when you define Project Parameters.

2. Changing the hierarchy of task assignment criteria after cost collection can distort facts

The user has to exercise extreme caution in modifying the hierarchy of task assignment criteria after some project transactions have been processed by the cost collector. Project expenditures would be distorted when the logic is changed. The user has to be aware of the consequences of such a change if the changes are decided to be implemented.

3. Using partial WIP job numbers as criteria

Task AutoAssignment allows the users to enter only unreleased WIP jobs as task assignment criteria. This ensures that all the WIP resource transactions for the jobs will be assigned appropriate tasks and costs will be transferred to Oracle Projects.

This validation does not apply for partial WIP jobs numbers entered with a wildcard. So when partial WIP job numbers with wildcards are entered as task assignment criteria, the users should ensure that no previously cost collected project WIP resource transactions that satisfy the task assignment rule exist.

4. Viewing Tasks assigned by Task AutoAssignment

The tasks assigned by Task AutoAssignment for Inventory and Resource transactions can be viewed in the following forms:

Transactions	Form	Zone	Field
Inventory Transactions: (Inventory responsibility)			
All Project Inventory transactions	View Material Transactions	Transaction Id	Task Number
Common Material Issue to Project WIP job	View Material Transactions	Transaction Id	Source Task Number
Resource Transactions: (WIP responsibility)			
All project resource transactions	View Resource Transactions	Project	Task Number

5. Viewing Errors in the task assignment process

The errors in the task assignment process for material transactions could be viewed in the View Material Transactions form in the Cost Management or Inventory responsibility. The alternate zone Transaction Id has columns Error Code and Error Explanation that show the errors in task assignment process.

Project Manufacturing Costing and Billing

This chapter discusses the four processes used to cost in Oracle Inventory and Work in Process transactions, to transfer such costs to Oracle Projects, and to import and correct the costed transactions in Oracle Projects.

This chapter does not cover Project Manufacturing costing functionality. See *Project Manufacturing Costing, Oracle Cost Management User's Guide* for information.

One of the primary capabilities of Oracle Project Manufacturing is the ability to accumulate manufacturing costs within manufacturing applications and transfer those costs to Oracle Projects.

This chapter discusses various topics related to project costing and billing in a manufacturing environment. The primary purpose is not to explain standard functionality of the various application modules used in Project Manufacturing which you can find in the User's Guides for each product. Instead the purpose of this chapter is to describe costing and billing issues as they relate to the combination of Oracle Project Manufacturing and Oracle Projects functionality.

The following topics are included:

- Costing of Project Inventory Transactions
- Costing of Project WIP Transactions
- Cost Processing
- Project Billing and Revenue Recognition

See Also

Project Manufacturing User's Guide

Oracle Cost Management User's Guide

Oracle Projects User's Guide

Costing of Project Inventory Transactions

Procurement Transactions

When you receive a purchased item into inventory, the purchase order quantity and cost, including any sales tax added to the purchase order, are averaged with the current quantity and cost of the item in the project or common cost group. Purchase order costs for inventory receipts are picked up by the Cost Collector and transferred to Oracle Projects. The expenditure type associated with the purchased item's material subelement is charged on a receiving transaction. Sales tax entered on the purchase order is combined with the total purchase order amount and is therefore charged to the expenditure type associated with the purchased item's material subelement. If you identify a specific expenditure type for tax on the Invoice Transfer Tab of the Project Parameters form, the tax expenditure type you define will only be assigned to tax matched to item distribution lines on the Payables invoice. The Transfer Invoice Charges to Projects section in this chapter discusses tax and other invoice charges in greater detail.

The invoice amount for a purchased inventory item may not match the purchase order cost because of a difference in item price, a change in the exchange rate for items purchased in a currency other than the functional currency of the Set of Books, or additional charges such as freight, tax, and other miscellaneous charges.

You can recognize actual paid invoice cost for your purchased inventory items in Oracle Projects. You can transfer any difference between the AP invoice amount and the PO amount for project and common project inventory items to Oracle Projects.

Please see the Transfer Invoice Charges to Projects section of this chapter for more information.

Project Cost Transfers

Project Inter-Organization Transfers

You can transfer project inventory from one organization to another by using either one of the following methods:

- Direct Transfer performed on the Inventory Inter-organization Transfer form
- Intransit performed on Internal Requisition/Internal Sales Order/Receiving forms

Note: Project Intransit Transfers cannot be performed from the Inventory Inter-organization Transfer form.

You can define Inter-organization Transfer relationships on the Shipping Network form. On this form you can setup FOB point, transfer credit rules, and inter-organization receivable, payable, and intransit accounts. You can also check the elemental visibility checkbox if you want all the cost elements (material, material overhead, resource, overhead, and outside processing) to be visible in the receiving organization.

If you check the elemental visibility checkbox and define a transfer credit percentage or amount, the transfer credit is grouped into the material overhead cost element in the receiving organization.

If you do not check the elemental visibility checkbox, all cost elements plus any transfer credit are grouped into the material element in the receiving organization.

Examples of this functionality using a Direct Transfer appear below:

Organization A ships a manufactured item X to Organization B. Organization B has a material overhead rate of 20% associated with Item X. Shipping Network Setups:

Elemental Visibility Checkbox: **Checked**

Transfer Credit Percentage: **10%**

	Cost in Organization A	Cost in Organization B
Material	500	500
Material Overhead	50	1,090*
Resource	1,000	1,000
Overhead	1,500	1,500
Outside Processing	200	200
Total	3,250	4,290

* Transfer Credit = 10% x 3,250 = 325

Material Overhead in Organization B = [20% x (3,250 + 325)] + 50 + 325 = 1,090

Assume the same data as above except that the Elemental Visibility Checkbox is **Unchecked**:

	Cost in Organization A	Cost in Organization B
Material	500	3,575*
Material Overhead	50	715**
Resource	1,000	
Overhead	1,500	
Outside Processing	200	
Total	3,250	4,290

*3,250 (Total Org A) + 325 (Transfer Credit) = 3,575

**20% (Overhead Rate) x 3,575 (Material Org B) = 715

Project Multicurrency Transactions

You can transfer an item from one set of books to another set of books having a different currency.

Permanent Cost Transfers

You can perform a permanent project cost transfer on the Projects>Control>Borrow, Payback, Transfer>Transaction>Project Transfer form. The weighted average cost of the item in the 'from project' cost group is transferred to the 'to project' cost group when you perform a project transfer.

Borrow/Payback Transactions (Temporary Transfers)

Borrow/Payback Transfers are typically performed by government contractors to comply with government standards and regulations, but could be used by non-government contractors to address weighted average cost variances related to temporary project transfer. You can use Borrow/Payback Transfers to borrow material for a project which has a shortage for an item. You can borrow from any other project which has the item on-hand and payback the replacement item at the original borrow cost. The borrowing project incurs any variance between borrow and replacement cost.

You can charge cost elemental payback variances to accounts that you setup on the cost group form. Default variance accounts can be setup at the organization level in

the PJM Organization Parameters form. Payback variances are picked up by the Cost Collector and transferred to Oracle Projects.

You can borrow items from any project which is valid in the transaction organization, but you cannot borrow from a common project. The lending project cannot borrow the same item from the borrowing project until the outstanding borrow has been paid back. You can perform multiple paybacks of partial quantities of the original borrow, but you cannot payback more than you borrowed.

For the borrowing project, MRP uses the scheduled payback date that you enter on the transaction entry form to schedule supply for the payback. You can see the Payback Demand and Supply on the Planner Workbench.

You can define aging buckets to view the status of the Borrow/Payback transactions. You can drill down to the original transaction detail.

An example of a Borrow/Payback transaction appears below. Project B is the borrowing project and Project L is the lending project.

Description	Quantity	Each (\$)	Total (\$)
Beginning Balance in Cost Groups for Item A			
Cost Group for Project B	0	0	0
Cost Group for Project L	5	10	50
Project B borrows Quantity 1 Item A			
<i>Transaction Detail for Borrow Transaction</i>			
Debit Project B Cost Group Inventory Account	1	10	10
Credit Project L Cost Group Inventory Account	(1)	(10)	(10)
Project B issues Item A to WIP			
<i>Transaction Detail for WIP Issue</i>			
Debit Project B WIP Job Accounting Class	1	10	10
Credit Project B Cost Group Inventory Account	(1)	(10)	(10)
Project B Receives Quantity 20 Item A @ \$12			
Debit Project B Cost Group Inventory Account	20	12	240
Credit PO Receipt Accrual Account	(20)	(12)	(240)
Balance in Cost Groups for Item A			
Cost Group for Project B	20	12	240

Costing of Project Inventory Transactions

Cost Group for Project L	4	10	40
Project B does Payback Transaction to Project L			
<i>Transaction Detail for Payback Transaction</i>			
Debit Project L Cost Group Inventory Account	1	10	10
Credit Project B Cost Group Inventory Account	(1)	(12)	(12)
Debit Project B Cost Group Payback Variance Account			2

If you perform a Borrow/Payback transaction between two tasks on the same project, you will shift some of the cost from your project inventory valuation account to the payback variance account if a change in item cost occurs prior to the payback transaction. The example below using the same data as above shows the effect of a Borrow/Payback between two tasks on the same project.

Description	Quantity	Each (\$)	Total (\$)
Beginning Balance in Cost Group for Item A			
Project Locator for Project B, Task 1	0	10	0
Project Locator for Project B, Task 2	5	10	50
Project B Task 1 borrows Quantity 1 Item A from Task 2			
<i>Transaction Detail for Borrow Transaction</i>			
Debit Project B Cost Group Inventory Account	1	10	10
Credit Project B Cost Group Inventory Account	(1)	(10)	(10)
Project B Task 1 issues Item A to WIP			
<i>Transaction Detail for WIP Issue</i>			
Debit Project B WIP Job Accounting Class	1	10	10
Credit Project B Cost Group Inventory Account	(1)	(10)	(10)
Project B Task 1 Receives Quantity 20 Item A @ \$12			
Debit Project B Cost Group Inventory Account	20	12	240
Credit PO Receipt Accrual Account	(20)	(12)	(240)
Balance in Cost Group for Item A			
Project Locator for Project B, Task 1	20	11.67	233.33
Project Locator for Project B, Task 2	4	11.67	46.67

Project B Task 1 does Payback Transaction to Task 2

Transaction Detail for Payback Transaction			
Debit Project B Cost Group Inventory Account	1	10.00	10.00
Credit Project B Cost Group Inventory Account	(1)	(11.67)	(11.67)
Debit Project B Cost Group Payback Variance Account			1.67
Balance in Cost Group for Item A			
Project Locator for Project B, Task 1	19	11.60	220.40
Project Locator for Project B, Task 2	5	11.60	46.40

In summary, the result of the payback transaction is the reduction of the cost group cost of the item from \$11.67 to \$11.60 caused by reaveraging at the borrow cost, with the difference of \$1.67 (24 items @ \$.07) charged to the payback variance account.

Miscellaneous Transactions

You can perform Miscellaneous Receipts into and Miscellaneous Issues out of project inventory. When you perform a Miscellaneous Receipt into project inventory, the cost group inventory valuation account(s) is debited and the account that you enter on the Miscellaneous Transaction form is credited. The amount of the receipt is picked up by the Cost Collector and transferred to Oracle Projects in the Inventory Transaction Source.

A Miscellaneous Issue credits the cost group inventory valuation account(s) and debits the account entered on the Miscellaneous Transaction form. The issue amount is picked up by the Cost Collector and transferred to Oracle Projects in the Inventory Transaction Source.

See the Overhead Section of this chapter for a discussion of overhead treatment on Miscellaneous Transactions.

Other Average Cost Transactions

Average Cost Update

If you perform an Average Cost Update on an item in a cost group, the change in cost will be charged to the Adjustment Account entered on the Average Cost Update form. The cost adjustment is NOT picked up by the Cost Collector for transfer to Oracle Projects.

Average Cost Variance

Average cost variances are generated when you issue additional material even though the inventory balance for that material is negative. Inventory balances can be driven negative if the Allow Negative Balances parameter is set in the Inventory Organization Parameters form.

Costs which are charged to the Average Cost Variance Account defined on the project cost group form are NOT picked up by the Cost Collector for transfer to Oracle Projects. The example below describes the out-of-balance condition between the project cost group and the cost held in Oracle Projects for the item:

Transaction	Quantity	Each (\$)	Total (\$)
PO Receipt #1 Item A into Project P, Cost Group CG	3	10	30
Project P1 WIP Job backflushes Item A	(4)	10	(40)
Balance Item A in Cost Group CG	(1)	10	N/A
PO Receipt #2 Item A into Project P, Cost Group CG	10	12	120
<i>Transaction Detail for PO Receipt</i>			
Debit Cost Group Inventory Valuation Account	9	12	108
Debit Cost Group Inventory Valuation Account	1	10	10
Debit Average Cost Variance Account for Difference			2
Credit Receipt Accrual Account			(120)
Total Item A in Project P in <i>Manufacturing</i>			
WIP	4	10	40
Inventory	9	12	108
Total	13		148
Total Item A in Project P in <i>Oracle Projects</i>			
PO Receipt #1	3	10	30
PO Receipt #2	10	12	120
Total	13		150

As you can see from this example, allowing issues which cause negative balances may result in a difference between manufacturing costs and costs held in Oracle Projects for your project.

Error Corrections

You can view errors and resubmit transactions with the following steps:

- In Cost Module View Transactions form, view your Material Transactions
- Select the [Reason, Reference] tab to determine whether any transactions have errors
- View the error message and correct the problem
- Using the Tools Menu Option on the View Material Transactions form, select and submit the
- items to process
- Requery the transactions and verify that costing has occurred

Costing of Project WIP Transactions

WIP Accounting Class

You setup WIP accounting classes to define the sets of valuation and variance accounts that you use to charge the production cost of assembly items. You may want to set up separate work in process and inventory accounts for various project types or groups. You must associate a WIP Accounting Class to a project cost group if you want to be able to select that class for your project WIP job. The Setup chapter describes WIP Accounting Class setup and defaulting logic.

WIP accounting class valuation accounts are charged when you issue components, charge resources, move assemblies, and complete assemblies. Movement of project material cost between inventory and WIP is not reflected in Oracle Projects because the material cost has been picked up by the Cost Collector at the time of initial acquisition (i.e., PO or Miscellaneous Receipt) into the project locator.

Resource Charging

You can charge resources, including outside processing, to a project WIP job at actual or standard rates. If you setup a resource to charge at a standard rate and then charge that resource to a project job at actual hours and rates, any variances calculated at job close will NOT be picked up by the Cost Collector for transfer to Oracle Projects.

Setup WIP Completion Costing Options

On the WIP Accounting Class form, you can define the method by which your completed assemblies are costed by defining the Completion Cost Source as System Calculated or User-Defined. You can set defaults for system completion in the WIP Parameters window and override them if necessary when defining the WIP Accounting Class.

If you select System Calculated, you can select the parameters which determine how resource costs are calculated as assemblies are completed from jobs into inventory. You can choose one of the following methods:

- Use Actual Resources: Resources costs are determined based on the actual costs that have been charged to the job.
- Use Predefined Resources: Resources costs are determined using the predefined (standard) resource cost.

Note: If you select Use Predefined Resources and enter actual labor hours and dollars to your WIP job, any variance from standard rates will be charged to the variance accounts you define for your WIP Accounting Class. The variances are not picked up by the Cost Collector for transfer to Oracle Projects.

If you select the User-Defined system option, you can choose Average or other user-defined cost type using the Cost Type Parameter. This cost type is then used to determine the cost for the assemblies being completed.

If there are uncleared costs left in the job, they are posted to the job variance accounts when the job is closed. Variances are not picked up by the Cost Collector for transfer to Oracle Projects. Residual costs could be left in the job if:

- The Auto Compute Final Completion option in the WIP Parameters Average Costing Region is checked 'Yes', but not all assemblies are completed or scrapped or
- The job incurs costs between the last final completion and the close transaction

When completing assemblies from a non-standard job with no routing, the resource rate associated with the Average Rates cost type is used.

Common Items Issued to Project WIP Jobs

When you issue common items to a project WIP job, the following steps occur:

- Cost of the common item is transferred into the project cost group
- Weighted average cost for the project cost group cost is calculated
- Common item issues to the project WIP job at the reaveraged project cost group cost

As a result of the above transactions, you can see separate accounting distributions for the steps listed above in the following example:

#	Account	Amount	Debit	Credit
1	Common Cost Group Inventory Valuation Accounts	Current Average Cost of Material (and Material Overhead, if applicable) in Common Cost Group		XX

2	Project Cost Group Inventory Valuation Accounts	Amount of Credit Transaction #1	XX
3	Project Cost Group Inventory Valuation Accounts	Current Average Cost of Item in Project Cost Group	XX
4	WIP Accounting Class Valuation Accounts	Amount of Credit Transaction #3	XX

Outside Processing

You can charge outside processing cost to your WIP job at standard or actual (purchase order) rates. You can assign a rate to your outside processing resource and check the standard rate checkbox on the routing operation for that resource if you want to charge at standard. Do not check the box if you want to charge the WIP job at PO cost.

If you charge standard outside processing rates to your WIP job, any variance between the PO cost and the standard rate is charged to the Purchase Price Variance account assigned in the Other Accounts section of the Inventory Organization Parameters form. The Purchase Price Variance amount is not picked up by the Cost Collector to be transferred to Oracle Projects.

If you charge outside processing to your WIP job at PO cost, you can charge any invoice price variance to your project by running the Transfer Invoice Charge Process. Please refer to the Transfer Invoice Charges to Projects section of this chapter for more information.

Project Scrap Transactions

If you want to charge scrap transactions to a specific GL account, you can check the Require Scrap Account checkbox on the WIP Parameters form. When you move an item to Scrap Step on the WIP Move Transactions form, you enter the GL account to charge for the scrapped item. Scrap transactions are NOT picked up by the Cost Collector for transfer to Oracle Projects whether or not you choose to charge the GL scrap account.

Overhead Application

The Setup chapter describes how to associate material overhead rates with items and how to setup a default overhead rate prior to setting up your items. If rates are defined, material overhead on purchased components is applied at the time of receipt of the asset item into the asset subinventory. Material overhead is not applied on receipts of asset items to expense subinventories, or on receipt of expense items into either expense or asset subinventories.

Material overhead on completed assemblies is applied when the assembly is moved from WIP to Inventory.

If you perform a miscellaneous receipt for an item which has a material and overhead cost for your cost group (even if you have zero on-hand quantity), the amount of the miscellaneous receipt will be split between material and material overhead based on the ratio of the two cost elements in your cost group.

For example, Cost Group A has the following cost for Item A:

Total Unit Cost	\$110
Material Cost	100
Material Overhead	10
Ratio of Material Overhead to Material	.1
Quantity On-Hand	0

Perform Miscellaneous Receipt of Quantity One Item A for \$132

Total Unit Cost	\$132
Material Cost	120
Material Overhead	12
Ratio of Material Overhead to Material	.1
Quantity On-Hand	1

The Setup chapter describes how to setup a user-defined Average Rates Cost Type to hold resource-to-overhead associations and current overhead rates. Resource overhead costs are charged to the WIP job as you charge resources. Overhead amounts are automatically reversed if you reverse the underlying resource charges.

Project Manufacturing transactions pass to Oracle Projects as Burdened Cost. You cannot apply any additional overheads to Manufacturing transactions for costing purposes by using Oracle Projects Burden Schedules. You can, however, use the Projects Burden Schedules to apply additional rates to Project Manufacturing cost for revenue recognition and billing.

You can assign burden schedules to project types or to individual projects in Oracle Projects. Burden schedules associated with burden structures hold burden multipliers and designate which expenditure types are burdened.

If you assign a burden schedule to a manufacturing project, the multipliers you define in the burden schedule are applied to costs imported from Project Manufacturing for revenue accrual and billing only. If you have associated a burden rate to your project manufacturing expenditure types on a burden schedule, the burden costs from the schedule are calculated when you generate the draft revenue and invoice process.

When you setup your burden structure, you must indicate if it is additive or precedence based. If you have multiple burden cost codes, an additive burden structure applies each burden cost code to the raw costs in the appropriate cost base and sums the total of all. A precedence burden structure is cumulative and applies each cost code to the running total of the raw costs burdened with all previous cost codes. The example below illustrates the use of the precedence formula.

Example of Overhead (Burden) Cost Calculation

Manufacturing Cost	Transaction Amount	Burdened Cost in Projects	Apply Burden Schedule (10% G&A, 20% Fee) Using Precedence Formula	Revenue and Billed Amount
Purchase Material 4 items @ \$25	100.00	\$100.00	$100 \times 1.1 \times 1.2$	\$132.00
Apply Material Overhead Rate = .2 Basis = Total Value	20.00	20.00	$20 \times 1.1 \times 1.2$	26.40
Charge Assembly Resource 100 hours @ \$10/hour	1,000.00	1,000.00	$1,000 \times 1.1 \times 1.2$	1,320.00
Apply Resource Overhead Rate = \$2.00 Basis = Resource Units (hours)	200.00	200.00	$200 \times 1.1 \times 1.2$	264.00

You can use the Oracle Projects Project Allocations feature to allocate any under or over-absorbed overhead balance from the General Ledger to Project Manufacturing projects. The Setup chapter discusses the setup of a project classification code to identify Project Manufacturing projects as targets for the allocation process.

Cost Processing

Process Flow

Inventory, WIP, and Invoice Charges are processed by several programs before they are visible in Oracle Projects. Figure 6-1 shows the flow of transaction costing and cost collection. Each program is explained in detail in the next section.

Figure 6-1 Transaction Costing and Cost Collection Flow

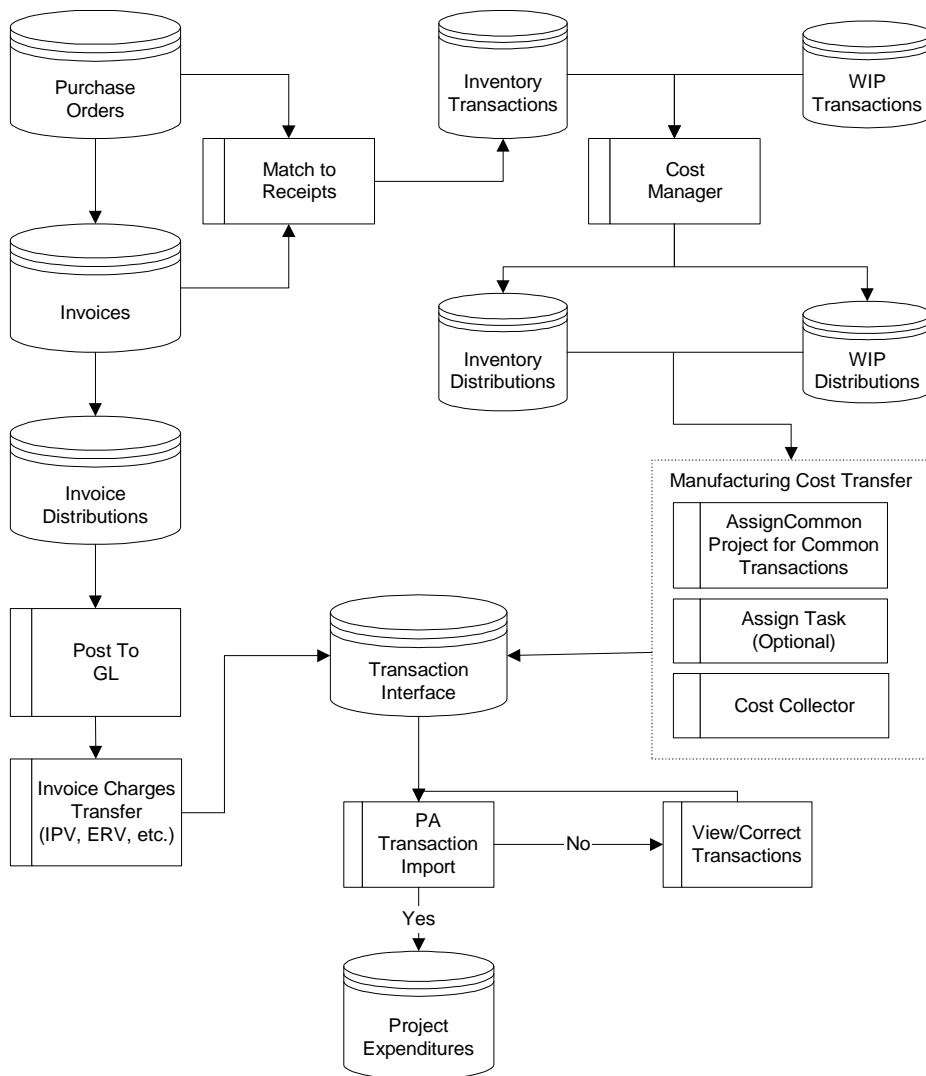

Programs

Cost Manager

The Cost Manager is a concurrent program you launch from the Inventory transaction Interface Manager form. It in turn launches the Cost Worker to cost Inventory and WIP transactions.

The task for the Cost Worker is to create accounting distributions for the transactions.

Project Cost Transfer (Cost Collector)

You can transfer costs for project and common (no specific project) transactions to Oracle Projects. See the Setup chapter for a discussion on setting up a common project. A process picks up the Common Project value defined on the PJM Parameters Form and assigns it to all transactions that have not been assigned a specific project number (common material related).

Oracle Project Manufacturing transfers Inventory and WIP costs to Oracle Projects via the program Project Cost Transfers. You specify the number of days to leave costs uncollected. When the batch job is submitted, both the Inventory and WIP costs are transferred to Oracle Projects.

The Cost Collector collects the costs of project and common-project transactions and passes these costs by project, task, expenditure type, expenditure organization, and expenditure date to the Transaction Import Interface table in Oracle Projects. These transactions can then be imported into Oracle Projects. The Cost Collector does not pick up transactions having the same project and task on both sides of the transaction, such as:

- Issue of components from project inventory to a WIP job which has the same project and task as the inventory locator
- WIP scrap transactions
- WIP assembly completions
- Shipment of items through Order Management

The Cost Collector processes (collects) transactions using Cost Collection Workers. Transactions that need to be collected and costed are grouped and a separate worker is assigned the job of collecting and costing transactions within a single group. A log file of all the validation and any SQL errors encountered while processing the transactions is maintained for each worker request. All program validation errors are updated in the transactions table.

Note: For more information on Cost Collector, see Oracle Cost Management User's Guide.

Transfer Invoice Charges to Projects

Invoice charges described in this section are defined below:

Invoice Price Variance (IPV) = Invoice Qty x (Invoice Price - PO Price) x Invoice Rate

Exchange Rate Variance (ERV) = Invoice Qty x PO Price x (Invoice Rate - PO or PO Receipt Rate)

Special Charges - tax, freight, handling, or any other miscellaneous cost

You can check a checkbox on the PJM Organization Parameters form to capture the IPV, ERV, or Special Charges to be transferred to Oracle Projects. You can also setup default expenditure types for each which populate the PJM Project Parameters form when you setup a new project.

The method you choose to match tax to your invoiced items determines which expenditure type is assigned to the tax you enter on the Payables invoice. You can allocate tax at the line match level or you can enter tax as an invoice distribution line and manually allocate it to item distributions.

If you allocate tax at the match to line level as described below, tax entered on the invoice will be charged to the IPV expenditure type:

- You can select the option of matching the supplier invoice to the purchase order or purchase order receipt on the shipments form of the purchase order. When you enter the Payables invoice, you select the same matching method that you chose on the purchase order.
- On the Match to Purchase Order form of Invoice Entry, you can check the Allocate checkbox next to each matching line to allocate tax, freight, and miscellaneous charges to the matched lines.
- Tax matched to a purchase order or receipt line on this form is designated as an invoice price variance - the difference between the tax amount allocated on the invoice and the tax entered on the purchase order line. In Oracle Projects you will see the Invoice Price Variance expenditure type on the transaction for tax allocated on the invoice.

If you allocate tax at the invoice distribution line level as described below, tax entered on the invoice will be charged to the tax expenditure type:

- You can select the same matching method on the invoice as you selected on the purchase order as described above and perform matching to lines, but do not check the Allocate checkbox.
- You can enter a new distribution line for tax on the Invoice Distributions form and hit the Allocate button.
- You can manually allocate the tax to any of the item distribution lines.
- Tax matched on this form is designated as a tax (not invoice price variance) and is charged to the tax expenditure type which you set up on the Project Parameters form.

Accounting distributions for project inventory IPV, ERV, and Special Charges are created and posted to the General Ledger in the Payables module. You must approve the invoice and create accounting (invoice action) prior to initiating the Transfer Invoice Charges Process. See the Oracle Payables User's Guide for more details.

The Transfer Invoice Charges Process generates a report which details the Purchasing and Payables activity which created the IPV, ERV, or special charge.

In order to balance your inventory cost to the cost held in Oracle Projects, you can run a process called Transfer Invoice Variance under Average Cost Update that adds the IPV and ERV costs to the on-hand balance of items in the project cost group. See Oracle Cost Management User's Guide for more details.

PA Transaction Import

When you import transaction information from Oracle Manufacturing, Oracle Projects records the transaction details and the source of the imported transactions during transaction import. Transaction Import automatically validates the transaction information and reports any exceptions. Oracle Projects does not import transactions more than once.

Transaction Sources

When you submit Transaction Import, Oracle Projects requires you to identify the source of the transaction you want to import. Project Manufacturing transactions sources are:

- Inventory
- Work in Process
- Inventory Misc

Figure 6-2 illustrates the types of transactions included in each transaction source. Note that the Inventory Misc transaction source is used for Inventory Integration with Projects (in a non-manufacturing installation). Miscellaneous Receipts and Miscellaneous Issues into or out of project inventory in Project Manufacturing are included in the Inventory transaction source.

Figure 6-2 Transaction Types Included with Each Transaction Source

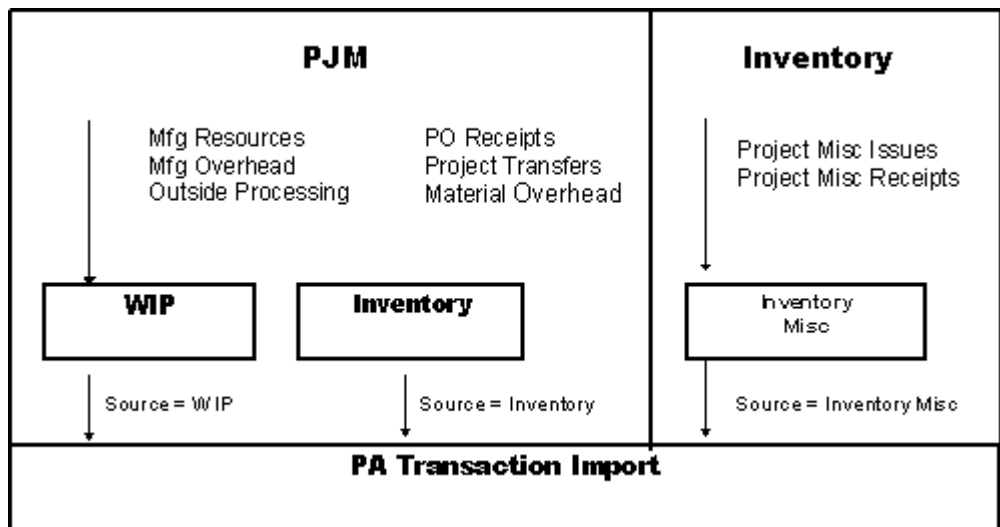

Submitting Transaction Import

Use the Run Requests form or choose Expenditures, Import from the Navigator window to submit the PRC: Transaction Import process. You must specify a transaction source when you submit this process.

Output Reports

Transaction Import has two output reports. The first allows you to review the number of successfully imported transactions, the second enables you to review transactions that were rejected by Transaction Import.

Note: For more information on Transaction Import, see Oracle Projects User's Guide.

View/Correct Transactions

Viewing Rejected Transactions Transaction records that fail the validation process remain in the interface table. If any one expenditure item in an expenditure batch fails validation, Oracle Projects rejects the entire expenditure batch. You can review pending and rejected transactions in the Review Transactions form. Only the transaction having invalid data will have a rejection reason specified.

Correcting Rejected Transactions If you need to make changes to the source information because of invalid data, you can correct the problem and import the batch again. For example, if the transaction is rejected because of an invalid task end date, you can either change the task ending date on the Project setup form or you can charge the transaction to a different task number on the Review Transaction form.

If you change the task on the rejected transaction form, save the change, and hit the Import button. Requery the form and verify that all the transactions in the rejected batch have been imported.

If you correct the problem by extending the task ending date on the Project form, requery the rejected transaction, reenter the same task on the form, save, and hit the Import button. Requery to insure that the batch has been imported.

You must change a field on the rejection form (even if you reenter the same data) and save the change in order for the transaction to be successfully imported. Saving the change causes the status to change from R (Rejected) to P (Pending).

Expenditure Type Classes for Project Manufacturing

For Project Manufacturing, Oracle Projects predefines the following three expenditure type classes for expenditures coming from Inventory and WIP:

Burden Expenditure Type Class

Burden transactions track overhead costs that are calculated in Manufacturing. These costs are created as separate expenditure items that have a burdened cost amount, but quantity and raw cost value of zero. Inventory material overhead and

WIP overhead are imported to Oracle Projects as Burden Transaction expenditure type class and cannot be adjusted in Oracle Projects.

Work in Process Expenditure Type Class

This expenditure type class is used for WIP resource and outside processing costs. You can also use this expenditure type class when you import other manufacturing costs via Transaction Import or when you enter transactions via pre-approved batch entry. WIP transactions that are interfaced from WIP to Projects cannot be adjusted in Projects. You should make any required adjustments in WIP and pass them to Oracle Projects.

Inventory Expenditure Type Class

This expenditure type class is used for the following transactions:

- Inventory transactions that are interfaced from Inventory to Oracle Projects. Inventory is the default expenditure type class associated with the material cost.
- Project Misc. Issues and Project Misc. Receipts transactions in a non-manufacturing installation (Project Manufacturing is not installed).

You can also use this expenditure type class when you import other manufacturing costs via Transaction Import or when you enter transactions via pre-approved batch entry. Adjustments for the inventory transactions interfaced from Inventory are not allowed, but are allowed for Project Misc. Issues and Receipts in a non-manufacturing installation.

The following table shows the Transaction Sources and Expenditure Type Classes are used for Inventory and WIP transaction:

DUPLICATE_ITEM	Self-explanatory
INVALID_END_DATE	Not valid week ending date
INVALID_PROJECT	Not valid project number
ITEM_NOT_IN_WEEK	Timecard item not in expenditure week
PA_EXP_TASK_TC	Violates task transaction control
PA_EX_PROJECT_CLOSED	Project is closed

See Also

Oracle Projects User's Guide

Project Billing and Revenue Recognition

You have the option of initiating project revenue recognition and customer invoicing through Order Management or Oracle Projects. You can make the choice on a project by project basis, but a better practice would be to consistently use one method.

One of the primary reasons to recognize revenue and initiate invoicing in Oracle Projects is to have visibility of project revenue and comparison to your revenue budget on the Project Status Inquiry. Another reason to use Oracle Projects is that Projects enables you to select different methods for recognizing revenue and invoicing by the association of distribution rules with your project. For example, you can recognize revenue on a percent complete basis and invoice the customer when the item ships.

Using Oracle Projects, for example, you can invoice the shipment of an item at the sales order price by performing the following steps:

- Verify that your project is setup with a distribution rule of Event/Event
- Enter Event details for type, date, bill amount, revenue amount, etc. under Billing -> Events
- Run the process to generate the draft revenue and invoice
- Review the revenue and invoice
- Run the processes to interface revenue to General Ledger and interface invoices to Receivables
- Run the AutoInvoice process in Receivables

If you want to recognize revenue and invoice your Project Manufacturing and non-Project Manufacturing cost as work occurs, you can perform these steps:

- Verify that your project is setup with a distribution rule of Work/Work
- Verify that the burden schedule which defaults from the project type is the one you want to use for this project
- Select billing schedules - Bill Rate or Burden - for your non-Project Manufacturing labor (for example., engineering labor from Projects timecards) and non-labor
- Run the process to generate the draft revenue and invoice
- Review the revenue and invoice

- Run the processes to interface revenue to General Ledger and interface invoices to Receivables
- Run the Autoinvoice process in Receivables

Oracle Projects allows you to generate draft invoices and draft revenue using separate processes, which you can run at different times. To allow for different billing cycles and revenue accrual, the distribution lines for General Ledger are created during invoice and revenue generation.

During the Generate Draft Invoices process, the account that is credited with the invoice amount is either the unbilled receivables account or the unearned revenue account, depending on whether you accrue revenue before or after you generate invoices.

If you do not require the Oracle Projects billing functionality described above, you can initiate billing through Order Management by performing the following steps:

- Setup a sales order cycle which includes a Receivables interface
- Associate this order cycle with a sales order type
- Assign this order type on your sales orders
- Fulfill the order by shipping the item(s)
- Confirm shipment and initiate the Receivables Interface process
- Run AutoInvoice process in Receivables

Project Cost of Goods Sold (COGS)

When you ship an item out of project inventory using Order Shipping Execution, you credit the project cost group inventory valuation accounts for the current average cost of the item in the cost group and debit the COGS account defined on the Organization Parameters Other Accounts form. You may not be able to use this method in a project environment because of the following reasons:

- Current cost of the item in inventory will probably not equal the correct amount of COGS if you have charged other non-manufacturing costs to your project through Oracle Projects timecard entry, supplier invoices, etc.
- Cost Collector does not pick up the COGS entry to transfer to Oracle Projects and as a result, you cannot see the COGS amount on the Project Status Inquiry

You can recognize a user-defined amount of COGS and display the amount on the Project Status Inquiry by using the Oracle Projects Cost Accrual Billing Extension to

recognize Cost of Goods Sold. Listed below is an example of how you can setup your accounts to accomplish this:

Project P1 is setup as follows:

- Charges cost of finished assemblies to FG Inventory Account
- Charges cost of non-manufacturing activities to PIP (Project-in-Process) Account
- Recognizes revenue and associated expenses (COGS) at time of assembly shipments

Transaction	Account and Cost	Debit	Credit
Ship Item	FG Inventory Account for current average cost of assembly in P1 cost group		XX
	PIP Account (enter this account as the COGS Account defined on Organization Parameters form) for amount of credit to FG Inventory Account	XX	
Recognize Revenue & Draft Billing in Oracle Projects	Unbilled Receivable Account for Revenue Amount	XX	
	Revenue Account for Revenue Amount		XX
	COGS Account for amount calculated in Cost Accrual Billing Extension	XX	
	PIP Account		XX
Bill Customer in Receivables	Accounts Receivable for Sales Price of Item (in this case, same as revenue amount)	XX	
	Unbilled Receivable for Revenue Amount		XX

General Ledger Posting

All Inventory and WIP transactions are posted to the General Ledger from Manufacturing. The distributions are transferred to Oracle Projects for information only – no posting of Manufacturing cost occurs in Projects.

Invoice Price and Exchange Rate Variances, Tax, Freight, and Miscellaneous Charge transactions are posted to the General Ledger through Oracle Payables.

If you process Project Manufacturing revenue and billing in Oracle Projects, the revenue and accounts receivable distributions are created and posted to the GL through Oracle Projects and Receivables.

If you process Project Manufacturing revenue and billing in Oracle Receivables (through Order Management, the revenue and accounts receivables distributions are created and posted to the GL through Oracle Receivables.

Project MRP

This chapter describes the Project MRP feature in Oracle Project Manufacturing. It also explains the Project MRP netting logic with specific examples for soft and hard pegged items.

The following topics are included:

- Overview of Project MRP
- Project MRP Setup
- Project MRP Planning Logic
- Planner Workbench in Project MRP
- Implementation Notes

Overview

Project MRP is one of a series of features in Oracle Applications designed to support companies that manufacture products for projects or contracts.

Project MRP allows you to plan in a project environment by separating all sources of supply and demand by project. This allows the planning process to identify components as common or project specific, track existing inventories by project, and provide visibility to all supply and demand associated with a project.

With Project MRP, you can:

- Include project numbers and task references in forecast, MPS, and MDS entries
- Load, copy, or merge forecast, MPS, and MDS entries with project numbers and task references
- Recognize and allocate supply according to project numbers and task references

- Combine project and related supply and demand with non-project related supply and demand in the same plan or schedule
- Perform netting by planning groups, project , and tasks
- Generate planned orders with project number and task references
- Implement planning suggestions by planning group, project, or task
- Link sales order lines, production orders, and purchase orders to projects and tasks, allocate onhand inventory to projects, and issue inventory to projects
- Perform on-line net change simulation in a project environment

Project MRP Setup

Selection of Project MRP plan options and choice of pegging attributes of an item together determine the output of a Project MRP plan. This section describes the Project MRP plan options and the item attributes that impact Project MRP planning logic.

See Also

Establishing a Project MRP Environment, *Oracle Master Scheduling/MRP & Oracle Supply Chain Planning User's Guide*

Project MRP Plan Options

Project MRP provides the following plan options to the users in the Oracle Project Manufacturing environment. There are multiple options available for Reservation Level and Hard Pegging Level in the Pegging region of the Plan Options form. The Pegging check box must be checked in order to access these plan options.

Reservation Level

The Reservation Level determines the method of pre-allocation of project supply to project demand. There are four options for reservation level.

Planning Group Choosing this option for a Project MRP plan will reserve project specific supply at the planning group level. Excess supply in one project can be reserved against demand for another project belonging to the same planning group. Excess common supply will also be allocated to project demand.

Project A project level reservation, will allow project specific supply to be used for demand specific to that project only. This option will allow cross allocation across tasks within the same project.

Task A task level reservation will reserve supply for a project-task against demand for the same project-task only. No cross allocation of material belonging to the same project but different tasks is allowed.

None Reservations for this option will take place like any non-project MRP planning process.

Hard Pegging Level

The Hard Pegging Level option determines if project and/or task references will be added to planned orders of hard pegged items only. (The Pegging item attribute must be either Hard Pegging or End Assembly/Hard Pegging) No project references are associated with planned orders of soft pegged items. Project MRP suggested planned orders will be assigned one of the following levels:

Project The planned orders generated for hard pegged items will carry project references only.

Project-Task This option will attach project and task references to the planned orders of hard pegged items.

None This option will not add any project/task reference to the Project MRP suggested planned orders.

Note: Hard Pegging Level options work independent of the Reservation Level options.

See Also

Oracle Master Scheduling/MRP & Oracle Supply Chain Planning User's Guide

Item Pegging Attributes

Item pegging attributes defined in Oracle Inventory determine the allocation of excess available supply for a project-task to the demand and the generation of Project MRP planned orders. Table 1 compares the available item pegging attributes.

Table 1: Comparison of Item Pegging Attributes

Item Pegging Attribute	Allocation of excess supply	Generation of planned orders
Soft Pegging, or End Assembly/Soft Pegging	Excess project or common supply is available to satisfy project demand of any project irrespective of plan options chosen.	Planned orders do not carry project and task references
Hard Pegging, or End Assembly/Hard Pegging	Excess supply in one project can be used for demand of a different project in the same planning group if reservation level is Planning Group. Excess common supply is also available for project demand only if the reservation level is Planning Group.	Planned orders carry project and task references as defined by the Hard Pegging Level plan option.
None	Disables project material allocation.	Planned orders do not carry any project or task references irrespective of the hard pegging level plan option.

Project MRP Planning Logic

Project MRP planning logic differs from the regular MRP planning logic primarily in the way it determines what supply is available to satisfy demand. It also differs in the way it assigns any suggested planned orders that result from the planning process.

Instead of simply considering existing inventories and scheduled receipts when netting supply against demand, the project MRP planning logic goes through a process of *pre-allocation*. Before netting supply against demand, the planning process analyses the project/task references (along with the item attributes, project parameters, and plan level options you have set), to determine what supply is available for meeting project demand. Supply and demand that is not specific to any project is defined as *common supply*. The project MRP planning logic treats common supply or demand as a Null project.

During the pre-allocation phase, the planning process first nets a project demand with its supply. It then checks the reservation level to determine if excess can be shared. This only works for items that have their attributes set to Soft Pegging, End Assembly/Soft Pegging, Hard Pegging or End Assembly/Hard Pegging.

Table 2 compares the logic in regular MRP and project MRP:

Table 2: Comparison of Regular and Project MRP

Regular MRP	Project MRP
Explode bill of materials	Explode bill of materials
Snapshot of inventory and supply/demand	Snapshot of inventory and supply/demand
	Pre-allocate supply to projects
Net supply against demand	Net supply against demand; assign suggested planned orders to projects

Netting Logic

By combining the item pegging attribute with the plan options reservation and hard pegging levels, you can exercise a high degree of control over how the planning process pre-allocates supply for an item. Table 3 summarizes the possible combinations and types of behavior you can enforce:

Table 3: Enforceable Behavior Types and Combinations

Reservation Level	Hard Pegging Level	Item Pegging Attribute	Netting Behavior
Planning Group	Project	Hard Pegging	Reserve supply at planning group level. Excess common supply will be used for project demand; Create planned orders at project level
Planning Group	Project-Task	Hard Pegging	Reserve supply at planning group level. Excess common supply will be used for project demand; Create planned orders at project-task level
Planning Group	None	Hard Pegging	Reserve supply at planning group level. Excess common supply will be used for project demand; Create planned orders without project references
Project	Project	Hard Pegging	Reserve supply at project level; Create planned orders at project level
Project	Project-Task	Hard Pegging	Reserve supply at project level; Create Planned orders at project-task level
Project	None	Hard Pegging	Reserve supply at project level; Create planned orders without project references

Table 3: Enforceable Behavior Types and Combinations

Reservation Level	Hard Pegging Level	Item Pegging Attribute	Netting Behavior
Project Task	Project	Hard Pegging	Reserve supply at project-task level; Create planned orders at project level
Project Task	Project-Task	Hard Pegging	Reserve supply at project-task level; Create planned orders at project-task level
Project Task	None	Hard Pegging	Reserve supply at project-task level; Create planned orders without project references
Planning Group	Any Value	Soft Pegging	Reserve supply at planning group level. Excess supply belonging to other projects and common will be used for project demand; Create planned orders without project references
Project	Any Value	Soft Pegging	Reserve supply at project level. Excess supply belonging to other projects and common will be used for project demand; Create planned orders without project references
Project Task	Any Value	Soft Pegging	Reserve supply at project-task level. Excess supply belonging to other projects and common will be used for project demand; Create planned orders without project references
None	None	Hard Pegging	No reservations, full pegging

Project Netting Examples

Soft Pegging

Table 4 shows an item that is an MRP-planned component used in four projects and as common.

During the pre-allocation phase of netting, the planning engine divides the supply for the item by project. In Period 1, the demand from project P2 is 100. Since there is an on-hand quantity of 25 for P2 and no schedules receipts, there is still demand for P2 of 75. To meet this demand, the planning engine looks for more P2 supply, which it finds in Period 2. The supply is pegged to the demand in Period 1. Project P1 has an excess of 75 in Period 1 (scheduled receipts plus the on-hand quantity minus P1 demand), which is then used to partially satisfy the P1 demand in Period 2. Period 1 also has common demand. To meet this demand, the planning engine allocates the receipts in Period 3, leaving an excess of 105. This excess has no further common

demand to meet. Period 3 has a demand from P4 of 120, which is reduced to 70 by P4 scheduled receipts. After satisfying all the project specific demand in the three periods we are left with an excess of 105 (common) in Period 1, and unmet demands of 42 P3 in Period 1, 75 P1 in Period 2 , 75 P2 and 70 P4 in Period 3.

The planning process can use other excess common supply in Period 1to meet the remaining demand for P3 in the same period. So 42 common are used to meet the P3 demand in Period 1. The remaining 63 common partially satisfy the P1 and P3 demand in Period 2, leaving an unmet demand of 62 in Period 2. The demand for 145 units in Period 3 remains unsatisfied.

This results in the planned orders for 62 in Period 2 and 145 in Period 3 without project and task references. Since the item is soft pegged, the planned orders will not carry any project reference irrespective of the Hard Pegging Level for the plan.

Table 4: MRP-Planned Component with Soft Pegging

Item pegging : soft pegging		On Hand = 5 (common)	
Reservation level : Project		On Hand = 10 (P1)	
Hard pegging level : Project		On Hand = 25 (P2)	
		On Hand = 18 (P3)	
A7004: MRP Planned	Period 1	Period 2	Period 3
Demand	100 (P2)	500 (P2)	300 (P2)
	200 (P1)	150 (P1)	120 (P4)
	65 (P3)	50 (P3)	
	400 (common)		
Scheduled Receipts	265 (P1)	800 (P2)	50 (P4)
	5 (P4)		500 (common)
Planned Orders		62	145
Projected Available	725 (P2)	225 (P2)	
	75 (P1)		
	63 (common)		

Hard Pegging

In Table 5, the item is an MRP-planned component used in four projects and also as common.

During the pre-allocation phase of netting, the planning engine divides the supply for the item by project. In Period 1, the demand from project P2 is 100. Since there is an on-hand quantity of 15 for P2 and no scheduled receipts, there is still demand for P2 of 85. The planning engine cannot apply excess from any other source to meet this demand: The planning engine looks for the available supply for P2 and finds it in Period 2. This supply is rescheduled to the demand in Period 1. The remaining demand from Period 1 (85) plus the demand in Period 2 (500) equals 585. The scheduled receipts leaves an excess of 15, which is carried forward (see the Projected Available).

Once again, the planning engine can only apply the excess P2 supply to P2 demand. The last P2 demand is in Period 3 (for 300), consuming the excess of 15 from Period 2 and leaving a net requirement of 285, which the planning engine converts into planned orders.

Because the item is hard pegged, and the hard pegging level (from the plan options) is set to *project*, the P2 project reference is added to the suggested planned order.

Similar logic applies to the supply and demand for projects P1, P3, P4, and common.

Table 5: MRP-Planned Component with Hard Pegging

Item pegging :hard pegging		On Hand = 5 (common)	
Reservation level : Project		On Hand = 10 (P1)	
Hard pegging level : Project		On Hand = 15 (P2)	
		On Hand = 18 (P3)	
A7004: MRP Planned	Period 1	Period 2	Period 3
Demand	100 (P2)	500 (P2)	300 (P2)
	200 (P1)	150 (P1)	120 (P4)
	65 (P3)	50 (P3)	
	400 (common)		
Scheduled Receipts	265 (P1)	600 (P2)	
	20 (P4)		
	600 (common)		
Planned Orders		75 (P1)	285 (P2)
			100 (P4)
Projected Available	515 (P2)	15 (P2)	0 (P2)
	75 (P1)	0 (P1)	0 (P1)
	53 (P3)	3 (P3)	3 (P3)
	205 (common)	205 (common)	205 (common)
	20 (P4)		0 (P4)

Hard Pegging (Common supply netting)

The new netting logic for Project MRP now also takes into account excess common supply for project demand for hard pegged items. This netting logic is available only if the reservation level option for the plan is set to Planning Group.

In a given period, the planning engine will look for supply that belongs to the same project. If there is a shortage, excess supply within the same planning group will be allocated. If unsatisfied demand still exists for the project, excess common supply will be used to satisfy project requirements. Excess common supply available in a period takes precedence over future scheduled receipts for the same project or planning group.

The difference in netting logic is explained below with the help of the same numerical example as above. In this case, projects P1 and P2 belong to the same planning group.

Netting of common supply and demand in leaves us with an excess of 205 in common. Similarly, for project P1 there is an excess supply of 75 in period 1.

In Period 1, the demand from project P2 is 100. Since there is an on-hand quantity of 15 for P2 and no scheduled receipts, there is still demand for P2 of 85. The planning engine can now apply excess from any other project belonging to the same planning group as well as excess common supply to meet this demand. In Period 1, the excess 75 in P1 is allocated to this demand. There is still an unsatisfied demand of 10 for project P2. As per the new netting logic, the excess in common is available for this project demand, thus satisfying all the requirements for project P2 in Period 1.

In Period 1, project P3 has an unmet demand of 47 (demand 65 - On hand 18). There is no other supply for P3. But there is excess common supply, which is used to meet this requirement. Notice that project P3 does not belong to any planning group. Just by virtue of the reservation level for the plan, excess common supply has been allocated to project demand for P3.

This excess in common is also applied to unsatisfied demand for projects P1 and P3 in Period 2, and project P2 in Period 3. The unsatisfied demand for 252 (P2) and 100 (P4) in Period 3 results in planned orders.

Because the item is hard pegged, and the hard pegging level (from the plan options) is set to *project*, project reference is added to the suggested planned orders.

Table 6: Common Supply Netting

Item pegging :hard pegging		On Hand = 5 (common)	
Reservation level : Planning Group		On Hand = 10 (P1)	
Hard pegging level : Project		On Hand = 15 (P2)	
		On Hand = 18 (P3)	
A7004: MRP Planned	Period 1	Period 2	Period 3
Demand	100 (P2)	500 (P2)	300 (P2)
	200 (P1)	150 (P1)	120 (P4)
	65 (P3)	50 (P3)	
	400 (common)		
Scheduled Receipts	265 (P1)	600 (P2)	
	20 (P4)		
	600 (common)		
Planned Orders			252 (P2)
			100 (P4)
Projected Available	0 (P2)	0 (P2)	0 (P2)
	0 (P1)	0 (P1)	0 (P1)
	0 (P3)	0 (P3)	0 (P3)
	148 (common)	48 (common)	0 (common)
	20 (P4)	20 (P4)	0 (P4)

Project MRP Pegging Logic

Generation of project and task references on planned orders is a function of the Hard Pegging Level plan option and the item attributes. Even though Project MRP does not display the project and task references on planned orders for soft pegged items, these references are maintained within the system. These are used if the children of this soft pegged item happen to be hard pegged items. The following example illustrates the pegging logic for Project MRP.

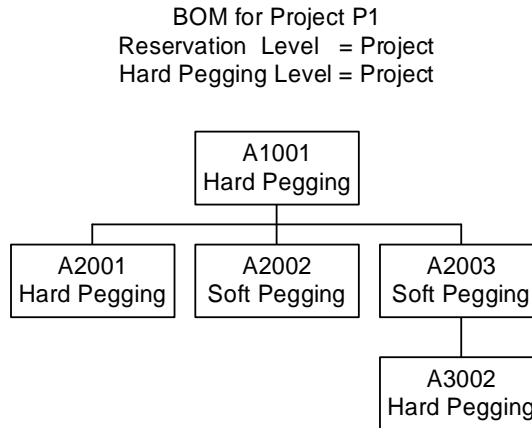
Figure 7-1 Project MRP Pegging Logic

In Figure 7-1, A2003 is a soft pegged item which has A3002 as its child item. A3002 is a hard pegged item. The Project MRP plan for A1001 has the Hard Pegging Level set to Project.

Being a soft pegged item, planned orders for A2003 will not carry any project reference. However, A3002 will carry a project reference on its planned orders even though the planned orders for its parent do not contain project references.

Order Modifiers in Project MRP

Project MRP uses the same Order Modifiers logic as standard MRP. The assignment of project references for hard pegged items (and Hard Pegging Level Project or Task) to planned orders occurs as per the logic shown in the following figure.

Any excess order quantity is assigned a project reference that belongs to a nearest future unsatisfied demand. In no demand exists, then the planned order will carry a null project and task reference.(for example, common supply).

Figure 7-2 Assigning Project References to Planned Orders after Applying Order Modifiers

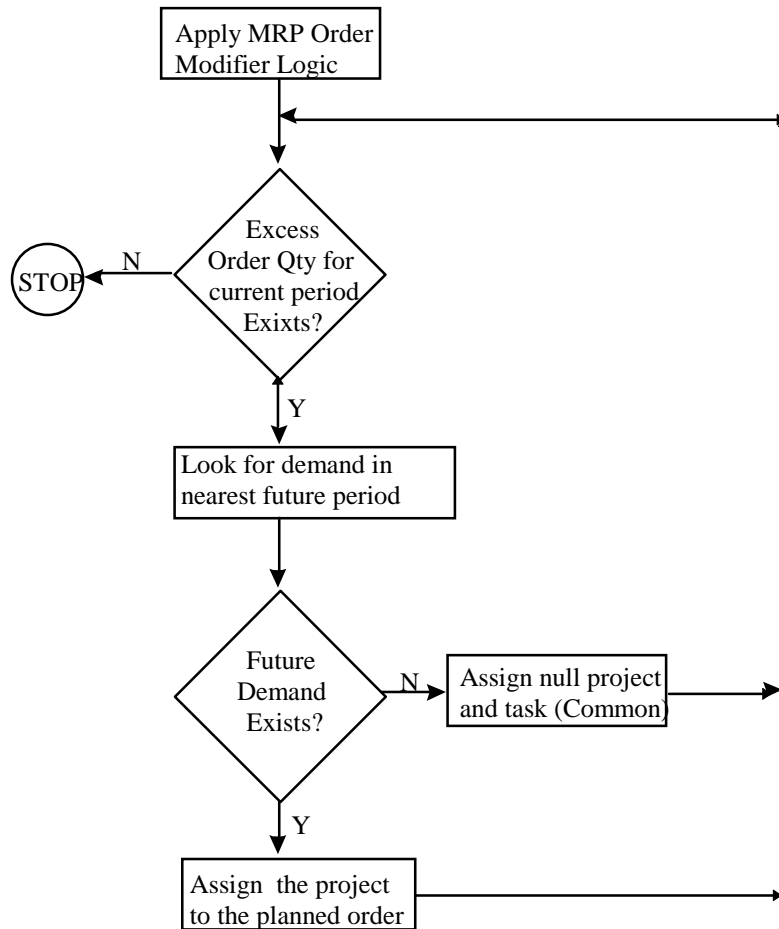

Planner Workbench in Project MRP

Viewing project material plans

The MPS Workbench and MRP Planner Workbench in Project MRP have significant enhancements to enable the planner in a Project Manufacturing environment to

conveniently view planning information by project and implement manufacturing plans in the workbench by project.

The planner can enter Planning Group, Project Number and/or Task Number as the search criteria in the Find Supply, Find Demand, or Find Supply/Demand window of the Planner Workbench. This enables the planner to find Supply, Demand, or Supply/ Demand information by planning group, project, or project-task.

The planner could also use customizable folders in the Supply, Demand, or Supply/Demand screens to query planning information for a particular project or project-task.

The Horizontal Plan and Enterprise View windows enable the planner to view supply and demand information by Planning Group, Project, and Project-Task. The planner can also choose to see the planning status of all the material or only common material in these forms.

See Also

Oracle Master Scheduling/MRP & Oracle Supply Chain Planning User's Guide

Workflow enabled project related Exception Messages in Project MRP

Along with the other MRP Exception Messages, Project MRP provides the following project related exception messages that can help monitor project material plans. Like other exception messages, these exception messages are also workflow enabled for better supply chain coordination. The Project Manager or Task Manager (if defined) will also be notified of these plan exceptions.

- **Items with Excess inventory in a project** This exception message enlists all the items that have a excess inventory in a project or project-task.
- **Items with Shortage in a project** This exception message highlights the items whose demand exceeds supply for that project or project-task.
- **Items allocated across projects** This exception message indicates items where supply for one project/task is used to satisfy demand for another project/task.

The Planner Workbench generates the following action messages for project supply. It follows the current Planning Time Fence and Acceptable Days Early logic to generate these messages.

- Reschedule In
- Reschedule Out
- Cancel

See Also

Oracle Master Scheduling/MRP & Oracle Supply Chain Planning User's Guide - Workflow Enabled Exception Messages

Implementing Project MRP plans

Using the features of the Project MRP Planner workbench, the planner can view and implement the planned orders by planning group, project or project-task. The planner can choose to override the suggested project and task references on planned orders. The Implement Property Sheet form allows the planner to view and change the Project or Project-Task of such planned orders. You can also simulate changes to dates, quantities, or project references in the Planner Workbench and generate net change simulation plans.

Implementation Notes

Forecast Consumption for projects

Project MRP does not support forecast consumption by project and task. An alternative would be to use demand classes to represent projects. Forecast consumption by demand classes is supported.

Issue of material to WIP across projects within the same planning group

Although Project MRP considers excess supply of material for one project as available to another project within the same planning group (if the reservation level is Planning Group), the material cannot be used directly across projects if the projects belong to different cost groups. A subinventory transfer is required if those items must be issued to a WIP job belonging to another project.

However, material belonging to one project can be issued to a WIP job of a different project if:

- Both the projects belong to the same planning group, and
- Both the projects share the same cost group, and
- PIM Org Parameter: Allow Cross Projects Issues is set to Yes.

Sales Orders Shipment (from inventory of a different project within the same planning group)

Sales order shipment from inventory belonging to a different project but in the same planning group is not supported. Project inventory should be moved to the correct project locator before sales order shipments have to be done for that project.

Supply Chain Projects

This chapter explains how to use Supply Chain Planning for multi-org projects in an Oracle Project Manufacturing environment.

The following topics are included:

- Overview of Supply Chain Projects
- Major Features
- Process Flow
- Simple Example

Note: This chapter discusses the planning features of Advanced Supply Chain Planning. Oracle Supply Chain Planning is also supported.

Overview of Supply Chain Projects

With Oracle Advanced Supply Chain Planning (ASCP), you can generate plans that include the entire supply chain. In a single step you can schedule and plan material and distribution requirements for multiple organizations, or centrally plan the entire enterprise. You can also include customer and supplier inventories in the ASCP process. Common material requirements can be included if desired.

Oracle ASCP lets you plan finished products, as well as intermediate assemblies and purchased items, for all facilities in your supply chain. Material plans for feeder plants and distribution centers automatically consider requirements originating from any number of other facilities. You can load planned order demand from multiple using-organizations into the master schedule of supplying organizations.

Release to Oracle's Purchasing and Work in Process applications permits multi-organizational execution of procurement and manufacturing plans for the project. Oracle's Purchasing and Order Management applications provide the vehicle for moving supply between multiple organizations. Procurement, manufacturing, and distribution activity is always visible to ASCP. Cost transactions incurred across multiple organizations can be accumulated to a single project.

Major Features

Along with the other features found in the Oracle Applications, Supply Chain Projects allows you to accomplish the following project-oriented activities:

- Determine a sourcing strategy for your project supply chain and apply it to all your items.
- Simultaneously plan project and common material requirements of multiple organizations in your supply chain.
- Use the Advanced Supply Chain Planner Workbench to analyze project-specific supply and demand records across multiple organizations.
- Consider project-specific supply and demand from customer and supplier inventories in your material plans.

- View project-oriented exception messages for a consolidated supply chain material plan.
- Initiate project-specific inter-organization supply via internal requisitions and internal sales orders.
- Collect all project related material, resource and overhead costs via Oracle Projects.

Attention: Use of Supply Chain Projects assumes a thorough knowledge of Oracle Advanced Supply Chain Planning, Order Management, Purchasing, Inventory, Costing, and other Project Manufacturing features. It also assumes a complete setup of all necessary inter-organization relationships within these applications. For more information on these applications, see their respective user's guides.

Process Flow

The following are the major steps necessary for successful execution of Supply Chain Projects:

Attention: The steps below reflect the basic flow, however, individuals steps may be executed in a different sequence than those listed. Depending upon the individual scenario, some steps may be executed several times before executing another or some steps may be omitted completely.

#	Step	Description	Implementation Notes
1	GENERAL	Supply Chain Projects is only supported within a given Set of Books.	Supply Chain Projects is only supported for those organizations that reside within a given Set of Books.
2	Set up Project-specific data	Set up Project Control Level within Organization Parameters.	It is advised that the Project Control Level be the same within each of the organizations to be used in the supply chain. Otherwise, unpredictable and/or confusing results may be experienced in the plan as supply and demand for different control levels cross organizational boundaries.

#	Step	Description	Implementation Notes
3		Define Project and any related budgets and agreements.	
4		Define project specific cost groups to maintain item cost by project.	Ensure that a cost group is completely defined for each organization to be used in the supply chain. Note: Although the Cost Group can be set as <i>multi-org</i> , the set up of account numbers and default WIP Accounting Class must be accomplished for each organization.
5		Link Cost Group, WIP Accounting Class and Project.	Ensure that these links are set for each organization to be used in the supply chain.
6	Set up supply chain	Create all necessary DRP, MDS, MPS and/or MRP names and related data.	
7		Create all necessary Sourcing Rules and related Assignment Sets for inter-organization demand and/or specific vendors.	
8	Execute Supply Chain Planning	Ensure that all appropriate Sales Orders are entered.	If desired, a Sales Order demand class can be established to represent a project or group of projects and then added to the Sales Order. Load/Copy/Merge of Sales Orders to MDS/MPS can be restricted to a specific demand class (for example, project).
9		Load/Copy/Merge data to appropriate MDS and/or MPS plan(s).	
10		Launch the appropriate plan(s).	
11	Review and Manage Plan(s).	Manage exception messages.	
12		Release appropriate WIP Jobs.	
13		Release appropriate Purchase Requisitions.	
14		Release appropriate Internal Requisitions.	

#	Step	Description	Implementation Notes
15	Initiate internal supply orders	Import internal requisitions for the Destination Organization.	Internal requisitions are NOT included in Project Commitments.
16		Create internal sales orders for the Source Organization.	In order for Internal Sales Orders to be visible to the Supply Chain plan, they must be included in the MDS or MPS via Load/Copy/Merge.
17	Procure materials	Create purchase orders to vendors.	
18		Receive purchase orders from vendors to component inventory.	
19	Manufacture sub-assemblies	Issue project and common materials to WIP.	
20		Apply resources and appropriate overheads.	
21		Execute any outside processing.	
22		Complete to sub-assembly inventory.	
23	Execute interorganization transfers	Ship internal sales orders from the Source Organization.	Direct transfers between organizations (for example, NOT utilizing In-Transit) are not available for Project Manufacturing materials.
24		Receive internal requisitions to appropriate inventory of the Destination Organization.	Upon receipt by the Destination Organization, all elemental costs are either combined into a single MATERIAL cost or handled as individual elements, depending on the setup option.
25	MANUFACTURE final assemblies	Essentially the same steps as 19-22 above. Complete to appropriate inventory.	
26	Ship assemblies	Ship the completed assemblies to customer(s) and/or appropriate distribution points.	
27	Collect and analyze project costs	Collect costs from each organization.	
28		Analyze costs via Oracle Projects.	

#	Step	Description	Implementation Notes
29	INVOICE customer	If appropriate, interface Project costs and invoice customer.	

Simple Example

Figure 8–1

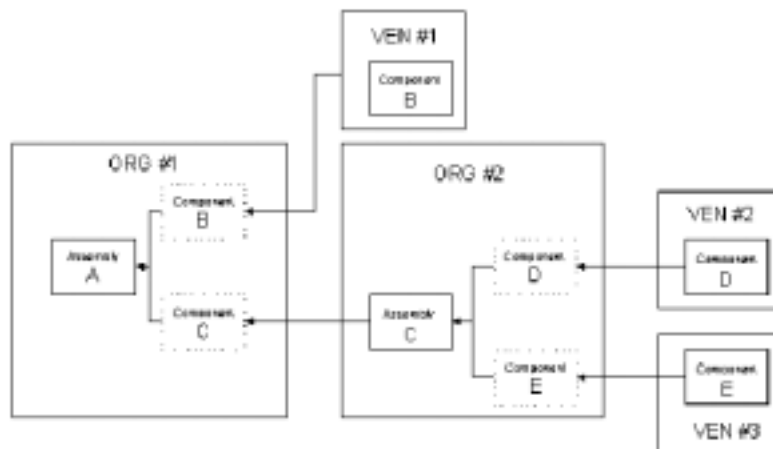

Assembly/Component	Sourcing
A	Produced in Organization #1
B	Purchased from Vendor #1
C	Internally acquired from Organization #2 Produced in Organization #2
D	Purchased from Vendor #2
E	Purchased from Vendor #3

Project Procurement

This chapter describes the key features related to project procurement. Both procurement-related material and services are described.

- Overview of Project Procurement
- Project Procurement Flow
- Project Commitments
- Implementation Notes

Overview of Project Procurement

Project Manufacturing uses Oracle Purchasing for project procurement. The system provides:

- Project and task references on purchase requisitions
- Project and task references on purchase orders
- Project and task references on blanket releases
- Project and task references on Request for Quotations (RFQs)
- Project and task references on purchase quotations
- Purchasing for project expense and project inventory items
- Commitments for project expense and project inventory items
- Project drop shipments
- Project outside processing
- Project internal requisitions
- Receipts into project inventory

See Also

Oracle Project Manufacturing without Oracle Projects, *Oracle Project Manufacturing Implementation Manual*

Project Procurement Flow

Figure 9 - 1 describes a generic high level Project Procurement flow.

Figure 9-1

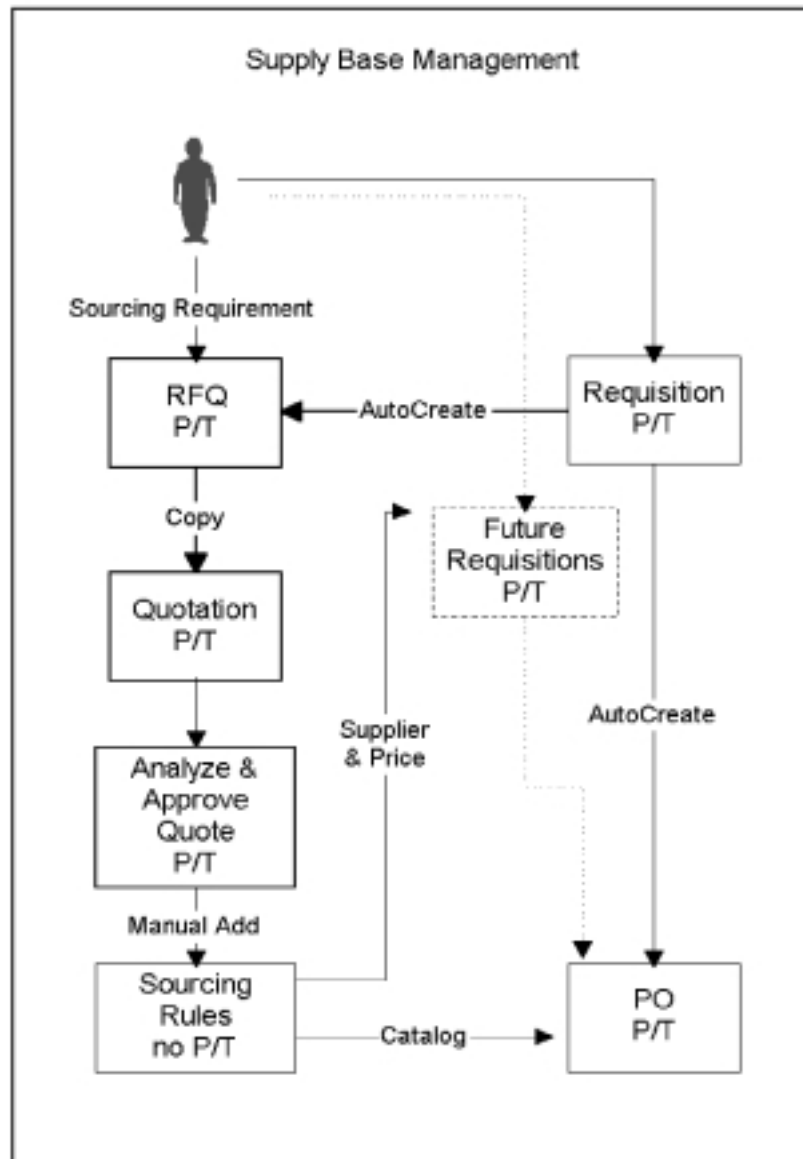

A complete project procurement cycle starts with the generation of a purchase requisition. The sources for creating a requisition are:

- Planned orders
- Drop shipments
- Outside processing operations
- Manual entry via Oracle Purchasing or Self Service Applications (Web Requisitions)
- Import from external systems (using ReqImport)

Depending on certain company regulations (or compliance with FAR/DFAR requirements) it might be necessary to generate a Request For Quotation (RFQ) for a requisition. A user can use the Auto-Create RFQ function to automatically convert the requisition into a RFQ.

The RFQ is typically sent out to one or more suppliers, who respond by sending in their quotes. The quote can be generated from a RFQ using the Copy functionality. The user can analyze and approve a quote and use the quote in Auto-Source Rules.

The last step is to create a project purchase order. The project purchase order can be automatically generated from a project requisition using the Auto-Create Purchase Order functionality, or entered manually.

Project Commitments

Project committed costs represent the outstanding requisitions and purchase orders charged to a project, and include recorded but unposted supplier invoices, or recorded but unposted deliveries to inventory or shop floor destination. You can report the total costs of a project by reporting the committed costs along with the actual costs.

Total Project Costs = Committed Costs + Actual Costs

You can report the flow of committed costs through Oracle Purchasing, Oracle Payables, and Oracle Inventory. These can include the following committed cost buckets (asset or expense items):

- Open Requisitions (unapproved or approved, unpurchased requisitions). These do not include internal requisitions.
- Open Purchase Orders (unapproved or approved, uninvoiced purchase orders).
- Pending Invoices (supplier invoices not yet interfaced to Oracle Projects).

- Manufacturing (PO delivery to Inventory destination: project subinventory/locator; or Shop Floor (outside processing) destination: project discrete job); all not yet interfaced to Oracle Projects).

Once either the supplier invoice, for expense items, or the PO delivery to inventory or shop floor, for inventory/shop floor destination items, is interfaced and posted to Projects, the related commitment is settled to zero and an *actual cost* recorded in the Project Cost Subledger.

You can report summary committed cost amounts for your projects and tasks and can review detailed requisitions and purchase orders that backup the summary amounts.

Attention: Essentially all of the commitment tracking occurs within Oracle Projects, specifically the Projects PSI (Project Status Inquiry) function. Oracle Purchasing reports PO Commitment *Initiations* in the *Purchase Order Commitment By Period Report*, but does not report downstream PO Commitment status changes or commitment settlements. PSI amounts may be exported to a spreadsheet for subsequent reporting.

Implementation Notes

During the implementation the following notes need to be considered.

Multiple Projects On One Document

MRP, Outside Processing, Internal Sales Orders, and Drop Shipments will generate one requisition for each planned order with one requisition line and one requisition distribution line.

A user can *manually* enter a requisition with multiple requisition lines. Each line can have a distribution line that can be associated with a project and task. For a Project Manufacturing environment we support the following scenarios for requisitions with ***inventory destination***:

- For each requisition line a user can enter one distribution line with project and task. (See Note below.)

- For each requisition line a user can enter multiple distribution lines with the same project and task. (See Note below.)
- For each requisition line a user can enter multiple distribution lines with different projects and tasks. (See Note below.)
- For each requisition line a user can enter one or multiple distribution lines without project and task (common inventory).

Note: Manual project requisitions entered via Self Service Applications (Web Requisitions) have one minor difference when compared to those entered via Oracle Purchasing. For user efficiency and ease-of-use, requisitions entered via Self Service Applications will only allow entry of the Project/Task data at the LINE level (NOT the distribution level).

In the scenario of multiple distribution lines with different projects and tasks the user will choose the *multiple lines* option during receiving, and the locator defaulting and validation logic will make sure that the correct project and task are propagated on the locator.

For purchases with *expense destination* a user can enter requisition lines with multiple distribution lines that each have a different project and task.

Expense Purchases

Expense and Inventory Purchases are costed differently in the system. Expense purchases result in invoices, are entered in Payables, and are imported into Oracle Projects using Transaction Import. Oracle Projects incurs the invoice costs.

Inventory Purchases

Inventory Purchases are received into Inventory using receiving functionality. Upon receipt into the destination location the purchase costs are posted to Oracle Cost Management and interfaced to Oracle Projects. For Inventory Purchases a user will also book invoices and invoice costs in Payables. Oracle Projects ignores these transactions during Transaction Import in order to avoid double counting.

Invoice Price Variances (IPV) can be automatically calculated and transferred to Projects.

For Inventory Purchases the system will check the Project Control Level for the destination inventory organization upon entry of the distribution line project and task. If the control level in the destination (receiving) organization is set to *Project*,

you can optionally enter a project and task. If the control level is set to *Project-Task*, you can enter a project. If you enter a project, you must also enter a task.

Auto-Create RFQ

In creating a RFQ from a requisition the following restrictions apply:

- A RFQ line with project and task is created for each requisition line during Auto-Create RFQ. The system will populate the project and task on the RFQ line from the first requisition distribution line for that requisition line.
- Grouping rules should not be used. A user should create one RFQ line for each requisition line with one distribution line.

Receiving

For more information on project locators validation and defaulting during receiving transactions, see the chapter *Setting Up*.

Note: Copying project quote to project purchase orders is not supported.

See Also

Oracle Purchasing User's Guide

Overview of Project Manufacturing Workflows

Oracle Project Manufacturing uses Oracle Workflow technology to provide guided walk-throughs of all steps required to define project manufacturing contract and indirect projects and to generate notifications for scheduling exceptions.

Oracle Workflow is a complete workflow management system that supports business process definition and automation. Its technology enables automation and continuous improvement to business processes, routing information of any type according to user-defined business rules. Oracle Workflow contains a graphical user interface that enables you to modify workflow processes to suit your business needs.

Oracle Project Manufacturing comes with the following workflows:

- Project Manufacturing Project Definition [Contract] workflow guides the user through the setup steps required to define a project manufacturing contract project. This workflow is seeded with one processes, the PJM Contract Type Project Definition process.
- Project Manufacturing Project Definition [Indirect/Capital] workflow guides the user through the setup steps required to define a project manufacturing indirect or capital project. This workflow is seeded with one processes, the PJM Indirect Type Project Definition process.
- Project Manufacturing Project Schedule Exception Notification workflow allows the user to define the notifications sent for schedule exceptions. This workflow is seeded with one process, the Project Manufacturing Integration Exception Process.

PJM Contract Type Project Definition Process

The PJM Contract Type Project Definition process provides a workflow-based approach to organize and launch the application forms needed to setup a project manufacturing contract project. The process provides sequential access to the needed forms from Oracle Projects, Oracle Master Scheduling, Oracle Work in Process, Oracle Cost Management, and Oracle Project Manufacturing.

The PJM Contract Type Project Definition process can be accessed through Oracle applications and through Workflow Builder. Use the Workflow Builder to customize the process.

►► To access the PJM Contract Type Project Definition Process:

1. Choose the Process tab on the navigator. The processes you can access are displayed on the upper left.
2. Select the PJM Contract Type Project Definition Process.

Customizing the PJM Contract Type Project Definition Process

Processes can be customized using the Oracle Workflow Builder. When you customize the PJM Contract Type Project Definition process, only process flows defined after you customize it are affected.

►► To display the process in the Oracle Workflow Builder:

1. Choose Open from the File menu, and connect to the database.
2. Select Project Manufacturing Project Definition [Contract] to open it.
3. Expand the data source, then expand the item type Project Manufacturing Project Definition [Contract].
4. Expand the Processes branch within the item type.
5. Double-click on the PJM Contract Type Project Definition Process to the display the diagram in a process window.

Figure 10–1 PJM Contract Type Project Definition Process

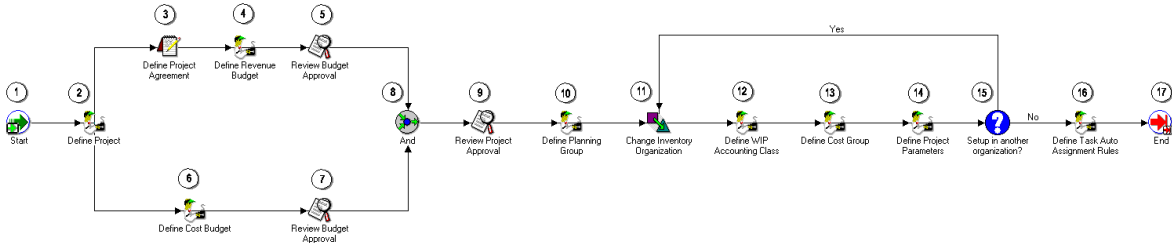

Required Modifications There are no required modifications for this workflow process.

Customization Example You can customize the PJM Contract Type Project Definition process by adding or deleting steps to the process, by changing process names and descriptions, and by changing step icons. For example, you might choose to remove Task Auto-Assignment from this process if your organization is at a project control level of task.

Customizations That Are Not Supported Each type of customization is supported for the PJM Contract Type Project Definition. However, the order of steps must take prerequisites for each form opened into account for the process to operate smoothly.

Creating a New Custom Process You can use the PJM Contract Type Project Definition process as a basis for developing your own project definition processes.

The Project Manufacturing Project Definitions [Contract] Item Type

The PJM Contract Type Project Definition process is associated with an item type called Project Manufacturing Project Definition [Contract]. All the available processes associated with an item type are listed under that item type in the Workflow Builder. Currently, the only available process for this item type is the PJM Contract Type Project Definition process.

The Project Manufacturing Project Definition [Contract] item type has two attributes associated with it. These attributes reference information in the demonstration application tables. The attributes are used and maintained by function activities throughout the process.

Table 10–1 Workflow Project Manufacturing Project Definition [Contract] Item Type Attributes

Display Name	Description	Type	Length/Format/ Lookup Type
User Name	Name of user defining project	Text	
Project Number	Number of project being defined	Text	

Summary of the PJM Contract Type Project Definition Process

To view the properties of the PJM Contract Type Project Definition process, select the process in the navigation tree and choose Properties from the Edit menu. This process has a result type of None, indicating that when the process completes, it does not end with any particular result, such as End (Approved) or End (Rejected). Instead, its subprocesses end with specific results.

This process is runnable, indicating that it can be initiated as a top level process to run by making calls to the Workflow Engine *CreateProcess* and *StartProcess* APIs.

The PJM Contract Type Project Definition process is designed to provide maximum flexibility for the user. Hence, no step in the process is required in order to complete additional steps. The user can select a project for which prerequisite steps have been completed to go on to further steps.

In order to provide this flexibility, the PJM Contract Type Project Definition process does not send message attributes from one step to the next.

The process contains 17 activities, each represented by a node on Figure B-1. The workflow begins at node 1.

PJM Contract Type Project Definition Process Activities

The following is a description of each activity listed by the activity's display name.

Start (Node 1)

This is a Standard function activity that marks the start of the process.

- Function - WF_STANDARD.NOOP
- Result Type - None
- Prerequisite activities - None
- Item Attributes Set by Function - None

Define Project (Node 2)

This step opens the Oracle Project forms required to define a project.

- Message - Define Project
- Respond Message Attributes - Form PA_PAXPREPR_PROJECT

Define Project Agreement (Node 3)

This step opens the Oracle Project forms required to define a project agreement.

- Prerequisite Activities - Previous step
- Message - Define Project Agreement
- Respond Message Attributes -Form PA_PAXINEAG_AGREEMENT

Define Revenue Budget (Node 4)

This step opens the Oracle Project forms required to define a revenue budget.

- Message - Define Project Revenue Budget
- Respond Message Attributes - Form PA_PAXBUEBU

Review Budget Approval (Nodes 5 and 7)

This step opens the Oracle Project forms required to review budget status for a project.

- Message - Review Budget Status
- Respond Message Attributes- Form PA_PAXBUEBU

Define Cost Budget (Node 6)

This step opens the Oracle Project forms required to define cost budget for a project.

- Message - Define Project Cost Budget
- Respond Message Attributes -Form PA_PAXBUEBU

Review Project Approval (Node 9)

This step opens the Oracle Project forms required to review project approval.

- Message - Review Project Status
- Respond Message Attributes -Form PA_PAXPREPR_PROJECT

Define Planning Group (Node 10)

This step opens the Oracle Master Scheduling/MRP forms required to define a planning group.

- Message - Define Planning Group
- Respond Message Attributes -Form MRP_FNDLVMUL_PLANNING_GROUP

Change Inventory Organization (Node 11)

This step opens the Oracle Master Scheduling/MRP forms required to change the Inventory organization.

- Message - Change Organization
- Respond Message Attributes - Form MRPCHORG

Define WIP Accounting Class (Node 12)

This step opens the Oracle Work in Process forms required to define the WIP accounting class.

- Message - Define WIP Accounting Class
- Respond Message Attributes -Form WIP_WIPSUMCL

Define Cost Group (Node 13)

This step opens the Oracle Cost Management forms required to define the cost group.

- Message - Define Cost Group
- Respond Message Attributes - Form CST_CSTFDCGA

Define Project Parameters (Node 14)

This step opens the Oracle Project Manufacturing form required to define the project parameters.

- Message - Define Project Parameters
- Respond Message Attributes -Form PJMFDPJP

Setup in Another Organization (Node 15)

This step refers the user back to Node 11 if additional organizations are desired for the project.

- Message - Continue Setup in Another Inventory Org?

Define Task Auto-Assignment Rules (Node 16)

This step opens the Oracle Project Manufacturing form required to define the task Auto-Assignment rules.

- Message - Define Task Auto-Assignment Rules
- Respond Message Attributes -Form PJMFTAAR

PJM Indirect Type Project Definition Process

The PJM Indirect Type Project Definition process provides a workflow-based approach to organize and launch the application forms needed to setup a project manufacturing indirect project. The process provides sequential access to the needed forms from Oracle Projects, Oracle Master Scheduling/MRP, Oracle Work in Process, Oracle Cost Management, and Oracle Project Manufacturing.

The PJM Indirect Type Project Definition process can be accessed through Oracle applications and through Workflow Builder. Use the Workflow Builder to customize the process.

►► To access the PJM Indirect Type Project Definition Process

1. Choose the Process tab on the navigator. The processes you can access are displayed on the upper left.
2. Select the PJM Indirect Type Project Definition Process.

Customizing the PJM Indirect Type Project Definition Process

Processes can be customized using the Oracle Workflow Builder. When you customize the PJM Contract Type Project Definition process, only projects defined after you customize it are affected.

►► To display the process in the Oracle Workflow Builder

1. Choose Open from the File menu, and connect to the database.
2. Select Project Manufacturing Project Definition [Indirect/Capital] to open it.
3. Expand the data source, then expand the item type Project Manufacturing Project Definition [Indirect/Capital].
4. Expand the Processes branch within the item type.
5. Double-click on the PJM Indirect Type Project Definition Process to the display the diagram in a process window.

Figure 10–2 PJM Indirect Type Project Definition Process

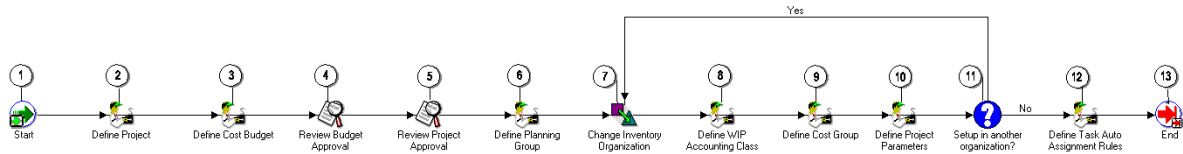

Required Modifications There are no required modifications for this workflow process.

Customization Example You can customize the PJM Indirect Type Project Definition process by adding or deleting steps to the process, by changing process names and descriptions, and by changing step icons. For example, you might choose to remove Task Auto-Assignment from this process if your organization is at a project control level of task.

Customizations That Are Not Supported Each type of customization is supported for the PJM Indirect Type Project Definition. However, the order of steps must take prerequisites for each form opened into account for the process to operate smoothly.

Creating a New Custom Process You can use the PJM Indirect Type Project Definition process as a basis for developing your own project definition processes.

The Project Manufacturing Project Definitions [Indirect/Capital] Item Type

The PJM Indirect Type Project Definition process is associated with an item type called Project Manufacturing Project Definition [Indirect/Capital]. All the available processes associated with an item type are listed under that item type in the Workflow Builder. Currently, the only available process for this item type is the PJM Indirect Type Project Definition process.

The Project Manufacturing Project Definition [Indirect/Capital] item type has two attributes associated with it. These attributes reference information in the demonstration application tables. The attributes are used and maintained by function activities throughout the process.

Table 10–2 Workflow Project Manufacturing Project Definition [Indirect/Capital] Item Type Attributes

Display Name	Description	Type
User Name	Name of user defining project	Text
Project Number	Number of project being defined	Text

Summary of the PJM Indirect Type Project Definition Process

To view the properties of the PJM Indirect Type Project Definition Process, select the process in the navigation tree and choose Properties from the Edit menu. This process has a result type of None, indicating that when the process completes, it does not end with any particular result, such as End (Approved) or End (Rejected). Instead, its subprocesses end with specific results.

This process is runnable, indicating that it can be initiated as a top level process to run by making calls to the Workflow Engine *CreateProcess* and *StartProcess* APIs.

The PJM Indirect Type Project Definition process is designed to provide maximum flexibility for the user. Hence, no step in the process is required in order to complete additional steps. The user can select a project for which prerequisite steps have been completed to go on to further steps.

In order to provide this flexibility, the PJM Indirect Type Project Definition process does not send message attributes from one step to the next.

The process contains 13 activities, each represented by a node on Figure B-2. The workflow begins at node 1.

PJM Indirect Type Project Definition Process Activities

The following is a description of each activity listed by the activity's display name.

Start (Node 1)

This is a Standard function activity that marks the start of the process.

- Function - WF_STANDARD.NOOP
- Result Type - None
- Required - Yes
- Prerequisite activities - None
- Item Attributes Set by Function - None
- Item Attributes Retrieved by Function - None

Define Project (Node 2)

This step opens the Oracle Project forms required to define a project.

- Message - Define Project
- Respond Message Attributes - Form PA_PAXPREPR_PROJECT
- Send Message Attributes

Define Cost Budget (Node 3)

This step opens the Oracle Project forms required to define the cost budget.

- Message - Define Cost Budget
- Respond Message Attributes -Form PA_PAXIBUEBU

Review Budget Approval (Node 4)

This step opens the Oracle Project forms required to review budget status for a project.

- Message - Review Budget Status
- Respond Message Attributes - Form PA_PAXBUEBU

Review Project Approval (Node 5)

This step opens the Oracle Project forms required to review project approval.

- Message - Review Project Status
- Respond Message Attributes -Form PA_PAXPREPR_PROJECT

Define Planning Group (Node 6)

This step opens the Oracle Master Scheduling/MRP forms required to define a planning group.

- Message - Define Planning Group
- Respond Message Attributes -Form MRP_FNDLVMUL_PLANNING_GROUP

Change Inventory Organization (Node 7)

This step opens the Oracle Master Scheduling/MRP forms required to change the Inventory organization.

- Message - Change Organization
- Respond Message Attributes - Form MRPCHORG

Define WIP Accounting Class (Node 8)

This step opens the Oracle Work in Process forms required to define the WIP accounting class.

- Message - Define WIP Accounting Class
- Respond Message Attributes - Form WIP_WIPSUMCL

Define Cost Group (Node 9)

This step opens the Oracle Cost Management forms required to define the cost group.

- Message - Define Cost Group
- Respond Message Attributes - Form CST_CSTFDCGA

Define Project Parameters (Node 10)

This step opens the Oracle Project Manufacturing form required to define the project parameters.

- Message - Define Project Parameters
- Respond Message Attributes - Form PJMFDPJP

Setup in Another Organization (Node 11)

This step refers the user back to Node 11 if additional organizations are desired for the project.

- Message - Continue Setup in Another Inventory Org?

Define Task Auto-Assignment Rules (Node 12)

This step opens the Oracle Project Manufacturing form required to define the task Auto-Assignment rules.

- Message - Define Task Auto-Assignment Rules
- Respond Message Attributes -Form PJMFTAAR

Project Manufacturing Integration Exception Process

When you submit a Project Schedule Exception Notification request, Oracle Project Manufacturing uses Oracle Workflow technology in the background to handle the notification process. Oracle Workflow defines the approval notification options

hierarchy available in the request parameters. You can use the Workflow Builder interface to modify your notification process.

The project manufacturing project schedule exception notification workflow consists of a single process, which is viewable in the Workflow Builder as a diagram. You can modify the objects and properties.

Customizing the Project Manufacturing Integration Exception Process

Processes can be customized using the Oracle Workflow Builder. When you customize the Project Manufacturing Project Schedule Exception Notification workflow, only those schedule exception notification requests that are submitted after you have customized it are affected. You can add or remove document types or alter the responsibilities to be notified for a given document type.

►► To display the workflow in the Oracle Workflow Builder

1. Choose Open from the File menu, and connect to the database.
2. Select PJM Project Schedule Exception Notification to open it.
3. Expand the data source, then expand the item type PJM Project Schedule Exception Notification.
4. Expand the Processes branch within the item type.
5. Double-click on the PJM Integration Exception Process to the display the diagram in a process window.

Figure 10-3 PJM Integration Exception Process Diagram

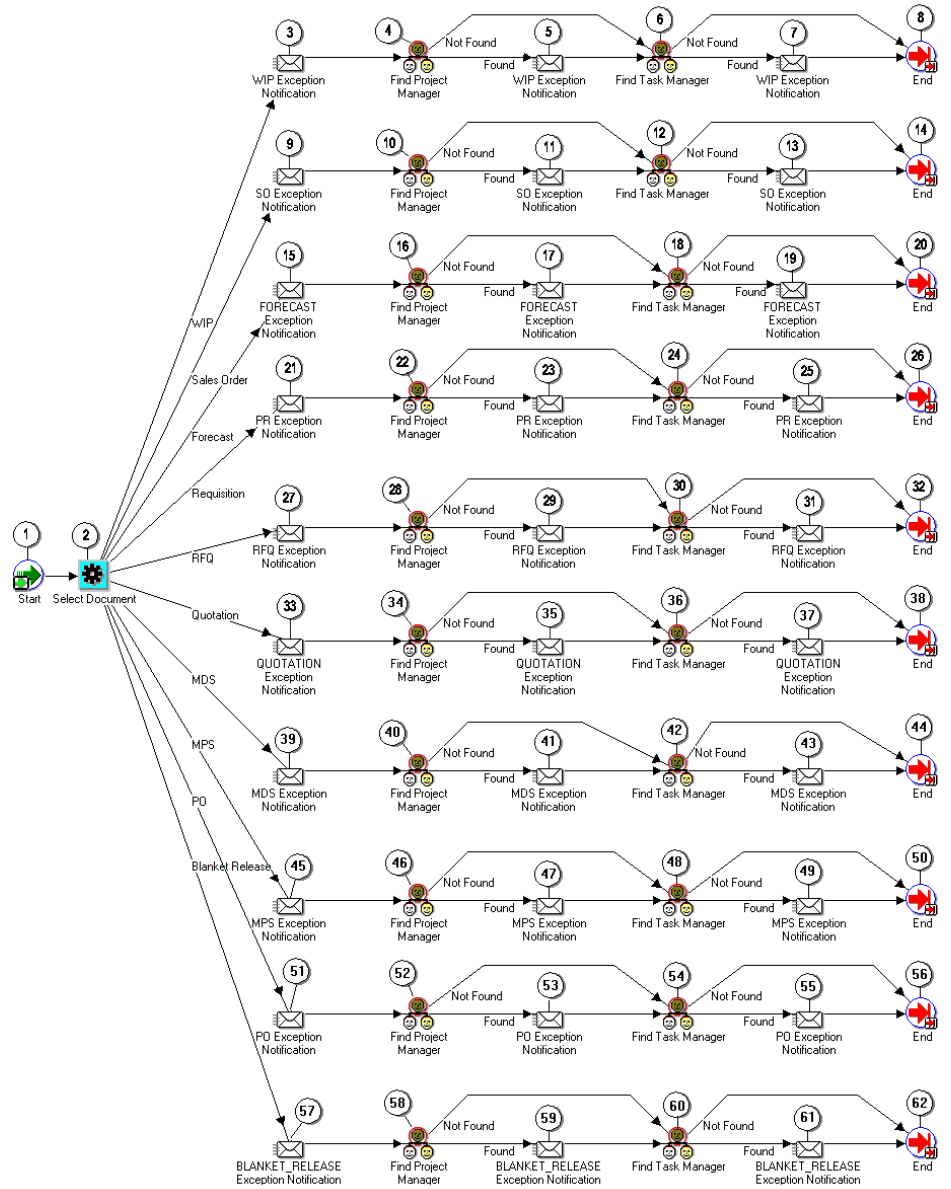

Required Modifications There are no required modifications for this workflow process.

You can customize the PJM Integration Exception process by adding or deleting steps to the process, by changing process names and descriptions, and by changing step icons.

Customization Example You might choose to customize this process by adding planners or buyers to the notification cycle.

Customizations That Are Not Supported Each type of customization is supported for the PJM Integration Exception Process. However, the order of steps must take prerequisites for each form opened into account for the process to operate smoothly.

Creating a New Custom Process You can use the PJM Integration Exception Process as a basis for developing your own project definition processes.

The Project Manufacturing Project Schedule Exceptions Notifications Item Type

The Project Manufacturing Integration Exception process is associated with an item type called Project Manufacturing Project Schedule Notifications. All the available processes associated with the item type are listed under that item type in the Workflow Builder. Currently, the only available process for this item type is the Project Manufacturing Integration Exception process.

The Project Manufacturing Project Schedule Notifications item type also has numerous attributes associated with it. These attributes reference information in the demonstration application tables. The attributes are used and maintained by function activities as well as notification activities throughout the process.

Table 10–3 Workflow Project Manufacturing Project Schedule Exceptions Notifications Item Type Attributes

Display Name	Type
Organization Name	Text
Document Type	Text
Date Type	Text
Tolerance Days	Number
Project Start Date	Date
Project End Date	Date
Task Start Date	Date
Task End Date	Date

Table 10–3 Workflow Project Manufacturing Project Schedule Exceptions Notifications Item Type Attributes

Display Name	Type
Project Name	Text
Task Name	Text
Wip Job Name	Text
Job Start Date	Date
Job End Date	Date
Item Number	Text
Requestor	Text
Exception Subject	Text
Exception Body	Text
SO Number	Text
SO Requested Date	Date
SO Promised Date	Date
Forecast Name	Text
Forecast Start Date	Date
Forecast End Date	Date
Requisition Number	Text
Need by Date	Date
RFQ Number	Text
Due Date	Date
Quotation Number	Text
Effectivity Start Date	Date
Effectivity End Date	Date
MDS Name	Text
PO Number	Text
Requested Date	Date
Promised Date	Date
Release Date	Date
Project Number	Text

Table 10–3 Workflow Project Manufacturing Project Schedule Exceptions Notifications Item Type Attributes

Display Name	Type
Task Number	Text
Status	Text
Quantity	Number
Job Type	Text
Start Quantity	Number
Quantity Completed	Number
Warehouse	Text
Ship to Location	Text
Ordered Quantity	Number
Delivered Quantity	Number
Forecast Set	Text
Project Manager	Role
Task Manager	Role
Open Form	Form
Item Description	Text
Line Number	Text

Summary of the Project Manufacturing Integration Exception Process

To view the properties of the Project Manufacturing Integration Exception Process, select the process in the navigation tree and choose Properties from the Edit menu. This process has a result type of None, indicating that when the process completes, it does not end with any particular result, such as End (Approved) or End (Rejected). Instead, its subprocesses end with specific results.

This process is runnable, indicating that it can be initiated as a top level process to run by making calls to the Workflow Engine *CreateProcess* and *StartProcess* APIs.

The process contains 62 activities, each represented by a node on Figure B-3. The workflow begins at node 1.

At node 2, this workflow branches depending on whether the document is a WIP, SO, Forecast, PR, RFQ, quotation, MDS, MPS, purchase order, or blanket release exception notification. If a choice is not made, the process is initiated for all options.

At nodes 3, 9, 15, 21, 27, 33, 39, 45, 51, and 57 the workflow notifies the requestor. locates the appropriate project manager for notification.

At nodes 4, 10, 16, 22, 28, 34, 40, 46, 52, and 58 the workflow locates the appropriate project manager for notification.

At nodes 5, 11, 17, 23, 29, 35, 41, 47, 53, and 59 the workflow sends notification to the appropriate project manager.

At nodes 6, 12, 17, 24, 30, 36, 42, 48, 54, and 60 the workflow locates the appropriate task manager for notification.

At nodes 7, 13, 18, 25, 31, 37, 43, 49, 55, and 61 the workflow sends notification to the appropriate task manager.

Project Manufacturing Integration Exception Process Activities

The following is a description of each activity listed by the activity's display name. You can create all the components for an activity in the graphical Workflow Builder except for the PL/SQL stored procedures that the function activities call. All function activities execute PL/SQL stored procedures which you must create and store in the Oracle RDBMS. The naming convention for the PL/SQL stored procedures is:

<PACKAGE>.<PROCEDURE>

<PACKAGE> is the name of the package that groups all of the procedures.

<PROCEDURE> represents the name of the procedure.

To view the package and procedure names used by the Project Manufacturing Integration Exception process, view the Properties page for each function activity. For example, the function activity Find Project Manager uses the <PACKAGE>.<PROCEDURE> name pjm_integration_proj_mfg.PJM_WF_SEEK_PROJECT_MGR.

Start (Node 1)

This is a Standard function activity that simply marks the start of the process.

Select Document (Node 2)

This function activity determines the document type: WIP, SO, Forecast, PR, RFQ, quotation, MDS, MPS, purchase order, or blanket release exception notification.

Exception Notification to Requestor (Nodes 3, 9, 15, 21, 27, 33, 39, 45, 51, and

57)

This activity sends schedule exception notification to the requestor.

Find Project Manager (Node 4, 10, 16, 22, 28, 34, 40, 46, 52, and 58)

This activity locates the appropriate project manager(s) for notification.

Exception Notification to Project Manager (Node 5, 11, 17, 23, 29, 35, 41, 47, 53, and 59)

This activity sends schedule exception notification to the project manager(s).

Find Task Manager (Node 6, 12, 17, 24, 30, 36, 42, 48, 54, and 60)

This activity locates the appropriate task manager(s) for notification.

Exception Notification to Task Manager (Node 7, 13, 18, 25, 31, 37, 43, 49, 55, and 61)

This activity sends schedule exception notification to the task manager(s).

ATO/PTO in Project Manufacturing

The following topics are included:

- Overview of Project ATO/PTO
- Process Flow
- Project/Task Defaulting Logic for ATO/PTO Options
- Other Implementation Notes

Overview of ATO/PTO in Project Manufacturing

Oracle Project Manufacturing enables you to process project Assemble-to-Order and project Pick-to-Order orders. You can:

- Define optional class and model bills of material
- Setup projects and project parameters
- Forecast model or option demand by project and/or task
- Master schedule model and option by project and/or task
- Enter sales order line for a model by project and/or task
- AutoCreate configuration item
- AutoCreate final assembly orders with project and/or task
- Complete a final assembly into project inventory
- Pick release and ship confirm from project inventory
- Cost configuration item by cost group
- Collect costs to Oracle Projects

Process Flow

Figure 11-1 illustrates the steps for an ATO/PTO process.

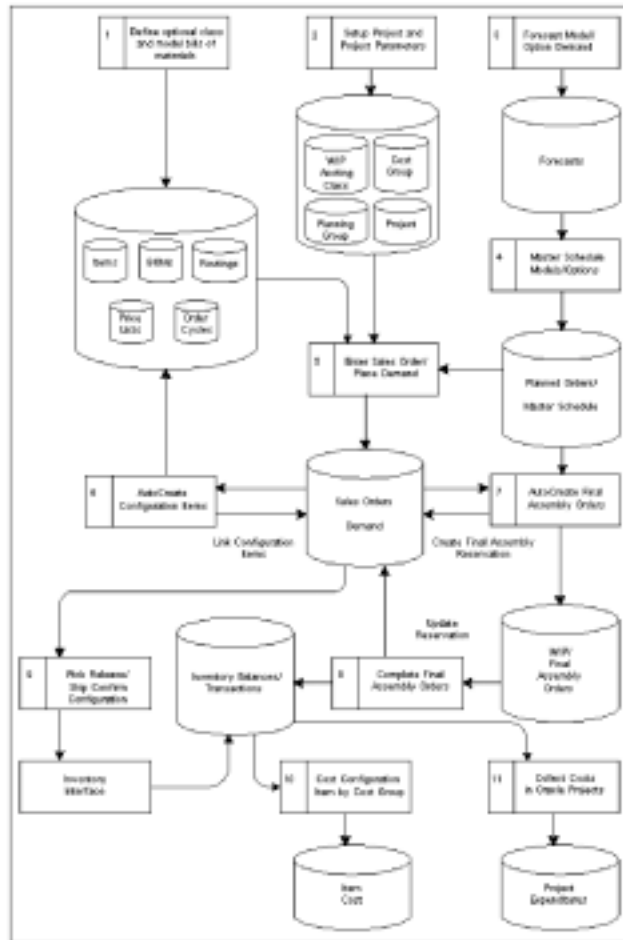

The following table describes the steps in processing a Assemble-to-Order (ATO) and Pick-to-Order (PTO) orders in a Project Manufacturing environment. It also provides you with the information you need to consider during implementation.

#	ATO	PTO	Step	Description	Implementation Notes
1	3	3	Define optional class and model bills of material.	Define multilevel model and option class bills to control order entry, master scheduling/MRP, work in process, and costing.	Since the configuration item inherits the item attributes from the ATO model item, the ATO Model item must be under Locator Control in order for the configuration item to be received into project locator. You cannot define project specific bills of material.
2	3	3	Setup a project and its project parameters.	Setup a project. Assign the project to a planning group (optional), a cost group and a default WIP accounting class.	For more information, see <i>Setup Project Parameters</i> : page.
3	3	3	Forecast model or option demand by project and/or task.	Forecast demand for model, options, or both by project and/or task. Explode forecasts through planning bills to models and/or options.	Forecast consumption by project/task is currently not supported. Use demand class instead.
4	3	3	Master schedule model and option by project and/or task.	Master schedule models, options, or both. (Cannot master schedule Pick-to-Order models however).	

#	ATO	PTO	Step	Description	Implementation Notes
5	3	3	Enter sales order line for a model by project and/or task.	<p>Enter sales orders for models with options. You can enter project and/or task on a sales order line. The project and task information is cascaded down to the option lines. You can update the project and task for an option line only if it belongs to a PTO model.</p> <p>For further detail, see <i>Project/Task Defaulting Logic for ATO/PTO Options</i>.</p>	<p>You can enter project/task on a sales order line if Project Enabled parameter is checked for the Warehouse (organization).</p> <p>Oracle Order Management provides two means by which to select configuration options: the Line Option window and Configurator window. Some fields are only available in the Line Option window, such as warehouse. Project/task information is only available in the Line Option window. If you need to update/view project/task information of the option lines, you can do so in the Line Option window.</p>
6	3		AutoCreate configuration item.	Automatically generate new item number, bill, and routing for each new sales order and link new item to sales order.	
7	3		AutoCreate final assembly orders by project and/or task.	<p>Automatically open project discrete job for each new ATO configuration order. Reserve work in process job to sales order.</p> <p>The project and task numbers on the project discrete job match the project and task on the sales order line for the ATO model.</p>	

#	ATO	PTO	Step	Description	Implementation Notes
8	3		Complete the final assembly into project inventory.	<p>Complete the configuration item to project inventory, automatically converting work in process reservation into inventory reservation.</p> <p>The project and task segments of the project locator must match the project and task on the sales order line for the ATO model.</p>	
9	3	3	Pick release and ship confirm from project inventory.	Pick Release all configuration sales orders for which on hand quantities for the project is available.	<p>For ATO configuration item, Pick Release will pick from the project locator that has the same project and task as those on the ATO model sales order line.</p> <p>For PTO options, since you can have different project/task from the project/task on the PTO Model line, Pick Release will pick from the project locator that has the same project and task as those on the option line.</p> <p>Pick Release will not pick from common locator.</p>
10	3	3	Cost configuration item by Cost Group	Automatically maintain item cost by Cost Group in Weighted Average Costing environment.	
11	3	3	Collect costs in Oracle Projects	Material costs (material, material overhead) and WIP costs (resource, overhead, outside processing) incurred for the project will be collected in Oracle Projects.	

Project/Task Defaulting Logic for ATO/PTO Options

The following table provides the detail logic of defaulting project/task information from a model line to its option lines in the Enter Sales Order form.

Action	ATO	PTO
Project/Task cascading from model line to option lines?	Yes	Yes
Project/Task updateable on options lines?	No	Yes
Project/Task validation on option lines?	N/A	Validation of project/task against warehouse on option line
Project/Task changes on model line	Re-cascade change to option lines	Re-cascade change to option lines, discarding user inputs Note: The following table lists the re-cascading rules for the hybrid case of an option itself being a model. The rules apply to project/task changes for the option line.

Hybrid Case	Re-cascading Rule
ATO model within PTO model	Re-cascade the project/task from the ATO model option line to the whole ATO sub-configuration.
PTO model within PTO model	No re-cascading. Users can manually update the project/task on the option lines of the sub-model.

Project Quality Collection

This chapter explains quality collection in a project manufacturing environment.

The following topics are included:

- Overview of Project Quality Collection
- Quality Process Flow

Overview of Project Quality Collection

Oracle Quality is an integrated quality management application designed to support the diverse data collection needs of discrete, repetitive, assemble-to-order, and batch process manufacturers. Oracle Quality helps you manage and distribute critical quality information throughout your organization.

Oracle Project Manufacturing enables you to use these capabilities in a Project Manufacturing environment:

- Define collection plans that include project and task as collection elements.
- Define actions and notifications specifically for project and task collection elements.
- Define item, customer or supplier type specifications specific to a project.
- Collect quality data including project and task collection elements.
- Analyze and report quality data based on a project and task.

Quality Process Flow

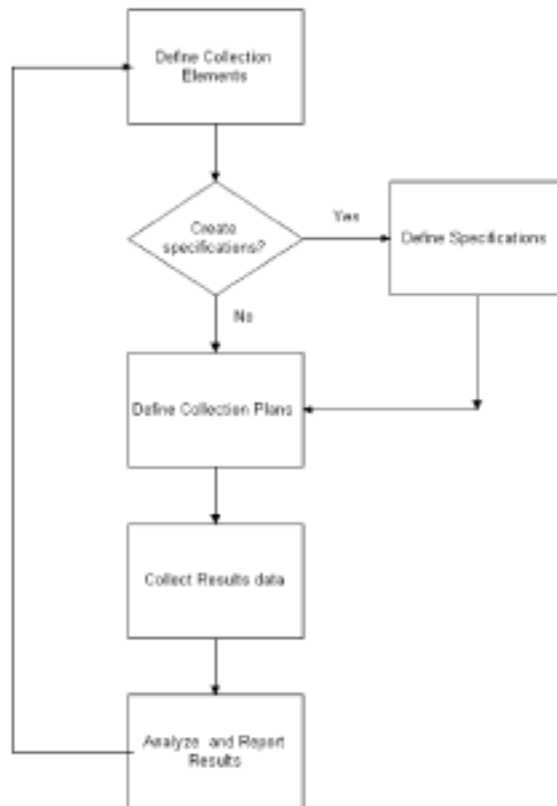

The following paragraphs describe each of the above steps in using Oracle Quality. The following example will be used to illustrate each step in the process.

Collection Elements

Collection elements in Oracle Quality determine what data to collect and report. You can define an unlimited number of collection elements for attributes such as defect, disposition, severity, cause, pass/fail results, or for variables such as voltage,

resistance, temperature, or acidity. A third group, reference information collection elements, reference database objects defined in other Oracle Applications - examples are Item, PO Number, Job, or Quantity. Project and task are among the reference collection elements now supported in Oracle Quality.

In our example, collection elements are Project Number, Task, Item, PO Number, PO Line Number, Quantity, Supplier, Thickness, Defect Code, Disposition Code, and Project Manager. Collection Element Project Manager will be populated based on the value you enter for Project Number. This can be done by using the *Assign a Value* Action for the collection element Project Number.

Specifications

Specifications describe the requirements of a product and can be created for items, suppliers, and customers. You can define specification limits for key characteristics of the products you produce or material you receive from suppliers. You can create item specifications by assigning a group of collection elements and their specification limits to items or categories of items. You can also create supplier specifications for items you receive from specific suppliers. Finally, you can create customer specifications specific to the product standards expected by customers. These three types of specifications help ensure that the goods you produce conform to your quality engineering standards and to your customers' quality standards. To provide more detail and flexibility, specification subtypes and specification elements are also provided.

In our example, item specification type will be used. For each specification which will be used for this collection plan, Item =A.

Specification Subtypes are used to create more granular specifications. For example, if a different but similar supplier specification is required when a supplier ships from one location versus another, you can use specification subtypes to ensure that the correct specification is applied.

In Project Manufacturing, specification subtypes can be used to effectively create project specific requirements. While defining a specification you should use Project Number as the collection element in the specification subtype field. This allows you to create multiple specifications for the same item/supplier/customer specification with the Project Number as additional criteria.

In our example, while defining specifications for item A for the collection element *thickness*, you could have 2 different projects that have slightly different acceptance criteria. Project #1 allows you to accept items which have a thickness range of .050 - .100 inches (specification range). Project #2 has a tighter range and allows only .055 - .080 inches (specification range). You can now create Specification 1 for Item

A, and specification subtype = Project #1 and Specification 2 for Item A, specification subtype = Project #2 with the corresponding specification limits. While using these specifications in data collection, you can find the correct specification using the Project Number as a search criteria.

Specification elements are the building blocks of specifications. Specification elements can be any data type but would most typically be numeric. You create specification elements by adding collection elements to your specifications. As you create specification elements, the specification limits, if any, are defaulted from the source (collection element). Specification limits include an acceptable target value as well as user-defined, reasonable, and specification range limits. The specification limits of a specification element can be updated as required.

In our example, the specification element is thickness, with the lower and upper spec limits for Specification 1 being .050 and .100. Lower and Upper Spec limits for Specification 2 would be .055 and .080.

Collection Plans

Collection plans determine what data to collect, where to collect it, when to collect it, and what action to take based on the data. Collection plans are similar to test or inspection plans. You can define an unlimited number of collection plans. Within each collection plan, you specify collection elements such as defect types, symptoms, causes, actions, critical measurements, as well as reference information like project and task number, item, lot number, supplier and customer. You should specify Project Number and task as mandatory collection elements - this will enable you to analyze and report your collected quality data by project and task.

Collection plans can be invoked manually for direct results entry. You can do this in the Quality Responsibility by using the Enter Quality Results forms and using the appropriate collection plan. They can also be automatically invoked as you enter transactions in other Oracle Applications. You can do this by setting up collection triggers based on the transactions such as Move Transactions, Completion Transactions, Work Order-less Completion Transactions (Oracle Work in Process), Receiving Transactions (Oracle Internet Procurement), Inspection Transactions (Oracle Internet Procurement) and Service Requests (Oracle Service) supported by Oracle Quality. Collection triggers are events or conditions that a transaction must satisfy before quality data collection is invoked. Collection elements that can be used to trigger these transactions are referred to as context elements and available in the list of values for each transaction type. Project and task are not context elements and hence cannot be used to trigger Quality data collection.

Attachments You can attach illustrative or explanatory files -- in the form of text, images, word processing documents, spreadsheets and video to collection plans. In a Project Manufacturing environment, attachments can be used to document instructions specific to a project or groups of projects. They can be viewed by operations personnel during quality data collection.

Actions As you collect quality data, actions can be invoked. You can assign actions and action rules to collection elements. As quality data is collected, results values are used in the evaluation of action rules associated with collection plan elements. When an action rule is found to be true, the action associated with that action rule is invoked. Actions are either specific to an Oracle Applications product, and act upon database objects associated with that product, or they are non-product specific. Example of Application specific actions could be putting a job on hold, a supplier on hold. Examples of non-product specific actions could be a message to the operator, an alert action. Alert actions supported by Oracle Quality include sending an electronic mail notification, executing a SQL script, executing an operating system script and launching a concurrent request. You can dynamically distribute mail messages by including output variables in the recipient fields.

Attention: See *Oracle Quality User's Guide* for additional details on setting up Alerts.

In our example, the collection plan will use Receiving Inspection transaction type. The data collection will be setup as Mandatory and Enabled to allow for data collection online. The collection plan will use Item Specification type. Collection elements will include Project Number, Task, Item, PO Number, PO Line Number, Quantity, Supplier, Thickness, Defect Code, Disposition Code, and Project Manager. Project Number and task will be used as mandatory collection elements to allow for data collection and analysis/reporting by project. Project Manager collection element will be populated based on the Project Number collection element. Collection element *thickness* will be associated with a specification limit and an email notification will be sent to the specific Project Manager (listed in the collection element Project Manager) when the value for *thickness* is not to specification limits on a PO line item. The collection plan will only be triggered as part of a Receiving Inspection transaction, when Item =A (trigger element).

Data Collection

You can enter quality results into the quality data repository directly, as you transact in other Oracle Manufacturing Applications, or using Collection Import. While entering data, you can find specifications associated with a collection plan. If a

specification type has been associated with the collection plan selected, you are prompted to find and select a specification of that type as you enter quality results. You can select a specification from the list of values or by entering search criteria - this could include Project Number, Serial Number and so forth.

In our example, when you perform a Receiving Inspection transaction for Item=A, you will be required to complete the quality data before you can commit your receiving transaction. The collection plan can be invoked from the Special Menu or from the Quality Button. Since multiple specifications are associated with this collection plan, you will have to select the appropriate specification to be used. This selection can be done by entering the Project Number in the spec subtype as your search criteria. Based on the Project Number, the appropriate specification limits will be listed in the collection plan for the collection element *thickness*. When the values for *thickness* are exceeded - email notification will be sent to the specific Project Manager as setup in the collection plan.

Analyze and Report Results

Oracle Quality provides you with powerful inquiries that enable you to quickly find quality results. You can define your own selection criteria based on collection elements used in the collection plan. You can view quality results using online, ad hoc queries and through printed reports.

In our example, if you have a data collection plan for receiving inspection for Item A you can view failure results that are specific to a project. Since the collection plan was setup for Item=A, the specific Project Number can be used as selection criteria in the results analysis and reporting.

See Also

Oracle Quality User's Guide

Project Order Management and Fullfillment

This chapter describes the use of order management and fullfillment capabilities in a project manufacturing environment.

- Overview of Order Management and Fullfillment
- Overview of Project Drop Shipment
- Process Flow
- Process Steps

Project Order Management and Fulfillment

Overview

Project Manufacturing uses Oracle Order Management for Project Order Management and Oracle Shipping Execution for Project Order Fulfillment. The system supports

- Project Quotations and Sales Orders
- Project Drop Shipments
- Project Fulfillment
- Project Return Material Authorization(RMA)
- Project Assemble-to-order (ATO) and Pick-to-order(PTO)
- Project Order Import

Project Quotations and Sales Orders

Quotations and Sales Order line, Shipment or Option can be linked to projects and project tasks. The project and task references specified on an order line will be defaulted to all its child shipment lines. If the order line is a model, the project and task defaults to all options specified for the model. If the project and task information is updated at any point in time, this information is cascaded to all child shipment lines from an order line and to all options from the model line. Please refer to the ATO/PTO chapter for details.

You can use the Order Organizer in Order Management to search for orders that have one or more lines with the project and task specified in the search criteria. You can also search for all order lines that have project and task specified in the search criteria.

Project Fulfillment

Oracle Shipping Execution supports delivery based shipping for order fulfillment. After manufacturing is complete, finished goods are automatically picked from project inventory upon pick release. You can also pick release by project or project task if multiple sales order lines for a warehouse belong to the same project or project task.

Project RMA

You can use Oracle Order Management to process Project RMAs. RMA line types have line type category Return. Some examples of the line types that are available in Oracle Order Management are return for credit without receipt of goods, return for credit with receipt of goods, and return for replacement. A RMA line is indicated by its Line Type, negative and highlighted item quantity and line total price. An order can have a mix of outbound (Regular) and inbound (RMA) order lines.

When a project sales order line is referenced in the RMA line, project/task reference from the sales order will be defaulted into the RMA line. This project and task information can be updated if the user needs to account for the return under a different project and task. Project task references cannot be updated on the RMA line after the RMA has been received.

You can receive RMAs in the same way as any other planned receipt. Receiving against an Project RMA has the same controls as for a Project Purchase Order receipt - for a receipt referring to a Project RMA, the project task locator segments default from the RMA line's project task references. Project task references defaulted into the receiving locator cannot be overridden. Returns can be inspected in the same way as any other receipt.

When project task references are associated with the RMA line, its receipt/issue transactions are costed according to the corresponding project cost group. All RMA related transactions such as RMA receipt or returns will not be sent to Oracle Projects.

Project Order Import

You can import project and task information into Sales Order Lines, Shipments and Options while importing a Sales Order.

Project Drop Shipments

Overview of Project Drop Shipment

Oracle Project Manufacturing enables you to use the following drop shipment capabilities in a project manufacturing environment:

- Define a line type that is linked to a workflow and includes a drop ship cycle.
- On the same sales order, combine items to be drop shipped from a vendor with standard items that are to be shipped from internal inventory by using the

source type as External for drop shopped items and Internal for internally sourced items.

- Link customer ship-to addresses defined in Order Management with the ship to location defined in Purchasing.
- Enter project and task references on each sales order line (different projects and tasks may be entered on each line of multi-line orders).
- Import approved purchase requisitions (and subsequently autcreate purchase orders) which reflect the project and task references from the sales orders.
- Capture drop shipment receipts into a subinventory and project locator.
- See no change in on-hand quantities for the subinventory and project locator at the completion of the receipt transactions.
- Query the status of purchase orders and subsequent vendor shipping actions for orders which are being drop-shipped.
- Collect procurement costs in Oracle Projects.Process Flow

The following process flow illustrates how drop shipments work in a project manufacturing environment.

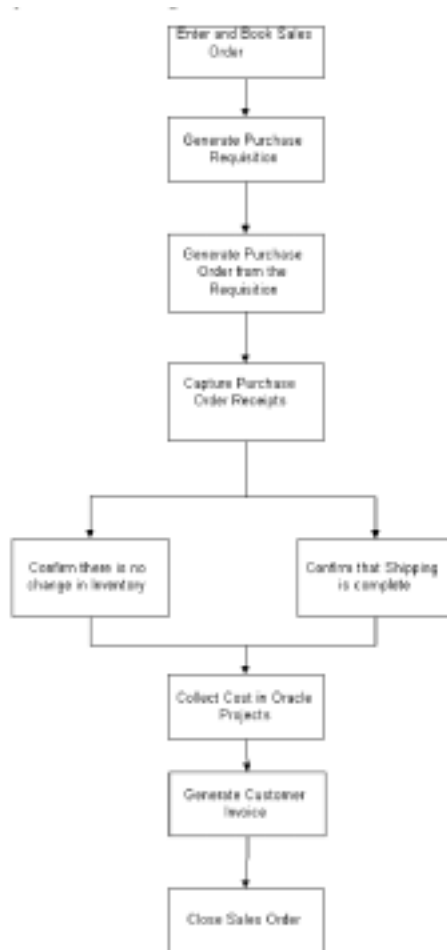

Process Steps

The following table describes the steps in processing a drop shipment order in a

project manufacturing environment.

#	Step	Implementation Notes
1	Enter and book sales order.	<p>On the sales order line, select External as the source type for the drop-ship items and Internal for an item you plan to fulfill from inventory. Verify that the Customer Address has been updated in the Customer Address Business Purpose Detail form - Internal section. The address of the drop-ship customer must also be updated in Setup Location form in Purchasing with Ship-To Site and Receiving Site checkboxes checked.</p> <p>You may enter a project and task for each line of the sales order.</p>
2	Generate Purchase Requisition.	Order Management will create requisitions for lines designated as drop shipment lines, using the ship-to address defined at the line level or order level of the sales order as the address to which a vendor must ship the items. One requisition line will be created for each sales order line. The project/task references should flow through from the sales order to the purchase requisition. You can use the right mouse button to determine the requisition number generated by your order on the Special - Purchasing Information menu option.
3	Generate Purchase Order from the Requisition.	Requisitions will be converted to standard purchase orders. Changes a buyer makes to a standard purchase order will have to be manually communicated to the order entry personnel.
4	Capture Purchase Order Receipts.	See <i>Oracle Purchasing User's Guide</i> , <i>Oracle Order Management</i> , and <i>Oracle Shipping User's Guide</i> for detailed information on how Oracle Purchasing captures vendor drop-shipment confirmations and Oracle Order Management's subsequent retrieval of this information. When the vendor sends only an invoice for drop shipments, you can manually perform a <i>logical</i> receipt of the quantity invoiced into a subinventory and locator with project/task reference. The project and task on the receipt will be validated against the purchase order and subsequent changes are not allowed.
5	Confirm there is no change in Inventory.	The update of the shipping information on the sales order and the inventory relief from the project location should occur simultaneously. You should not see a change in the on-hand quantities for the subinventory and project location at the completion of the receipt transaction.
6	Confirm that shipping is complete.	Check for partial shipments or over-shipments to determine if additional vendor/customer communication is necessary.
7	Collect cost in Oracle Projects.	You should be able to see Commitments on the Project Status Inquiry from the time of creation of approved Purchase Requisitions through conversion of the Commitments into <i>actual</i> costs upon capture of the Purchase Order Receipts.

#	Step	Implementation Notes
8	Generate customer invoice.	You use standard Order Management or Oracle Projects invoicing functionality to invoice an order. You may need to manually apply to the customer invoice any landing or special charges the vendor may have imposed on a drop shipment.
9	Close sales order.	After fulfilling an order and generating an invoice, you close an order.

See Also

Drop Shipment, *Oracle ShippingExecution User's Guide*

Purchase Order, *Oracle Purchasing User's Guide*

Other Implementation Notes

ATP by Project

ATP by project is not supported currently. Use demand classes to represent a project instead.

See Also

Project Manufacturing Costing, *Oracle Cost Management User's Guide*

Project, *Oracle Projects User's Guide*

Model/Unit Effectivity

This chapter explains the Model/Unit Effectivity feature of Oracle Project Manufacturing. It describes the setup steps for using model/unit numbers in manufacturing, the definition of model/unit numbers for items and the use of model/unit numbers in order management, planning, engineering, procurement, and production. Topics include:

- Overview of Model/Unit Effectivity
- Model/Unit Number Effectivity Features in Oracle Project Manufacturing
- Using Model/Unit Effectivity with Other Oracle Applications

Overview

Model/Unit Effectivity, also known as end item serial effectivity or just serial effectivity, is a technique employed by many highly configured or make-to-order or engineer-to-order manufacturing organizations to control the effectivity of changes to bills of material and routings. By specifying a model/unit number as the effectivity, the company is cutting-in a particular change at a specific deliverable end item. The change can be effective for only one model/unit number of the product family or for a contiguous block of model/unit numbers. This technique does not use date to control effectivity and thus provides customers who engineer and manufacture long lead time products a convenient way to specify engineering changes. This change can occur at any level in the bill of material structure of the end item.

By using model/unit effectivity, the organization has many versions of the same end item part number. In order to identify a model/unit effective item, the item number by itself is insufficient. The unique identity of the item is a combination of the item number and the model/unit number of the end item.

You must be a licensed user of Oracle Project Manufacturing in order to use the model/unit effectivity features in any Oracle applications.

Note: A model/unit number in this document is synonymous with the term Unit Number which appears on various forms in Oracle Applications.

Model/Unit Effectivity - Example

The bill shown in Figure 14-1 provides an example of using model/unit effectivity for defining item configurations. Shaded boxes for the items represent a model/unit effective item. All other items are date effective.

Figure 14–1 Model/Unit Effective Bill for F-90 Jet effective for Unit Numbers F90-01 to F90-10

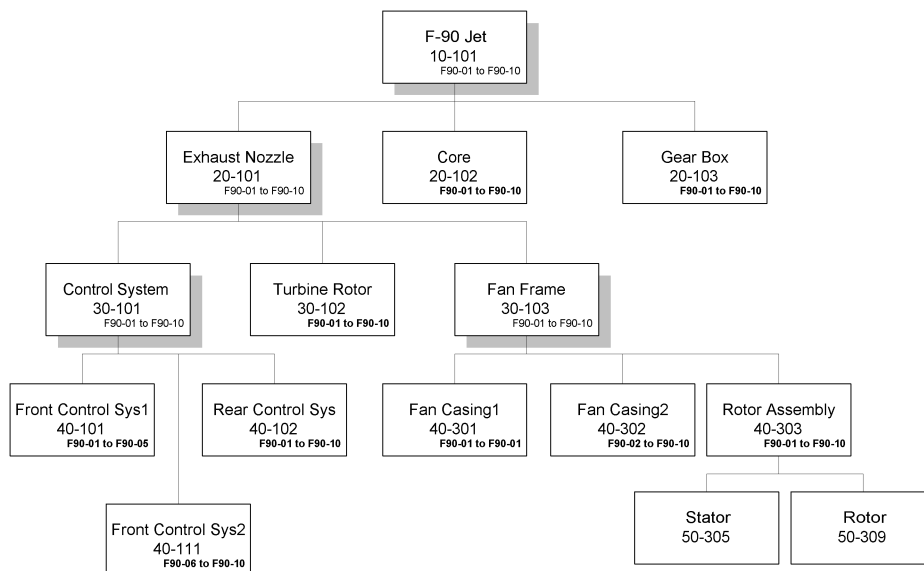

Components of a model/unit effective item can be defined to be effective for a single model/unit number (for example, Fan Casing1 40-301) or it could be defined to be effective for a range of model/unit numbers (for example, Fan Casing2 40-302)

Note: Note the following in the above bill of material definition:

- Model/unit effective items can have date effective items or other model/unit effective items as components. For example, F-90 Jet (10-101) has both date effective (20-102 and 20-103) and model/unit effective (20-101) items as its components.
 - All components in the bill of a model/unit effective item must be effective for a single model/unit number or for a range of model/unit numbers. This is also true for date effective components of model/unit effective assemblies. For example, even though Core (20-101) is a date effective item, you must specify a model/unit number when the item appears on the bill of a model/unit effective parent, F-90 Jet (10-101).
 - Bills for date effective assemblies cannot have unit effective components and you cannot enter model/unit effectivity on these bills. For example, Rotor Assembly (40-303) is a date effective component in the bill of model/unit effective item Fan Frame (30-103). The bill of Rotor Assembly can have only date effective items as its components and you cannot specify model/unit numbers on the bill.
-
-

Explosion of an end item with a specific unit number will yield different configurations of the same end item.

Figure 14-2 shows the configuration for F-90 Jet (Item Number 10-101) with a model/unit number F90-01.

Figure 14-2 Bill of Material for F-90 Jet for Unit Number F90-01

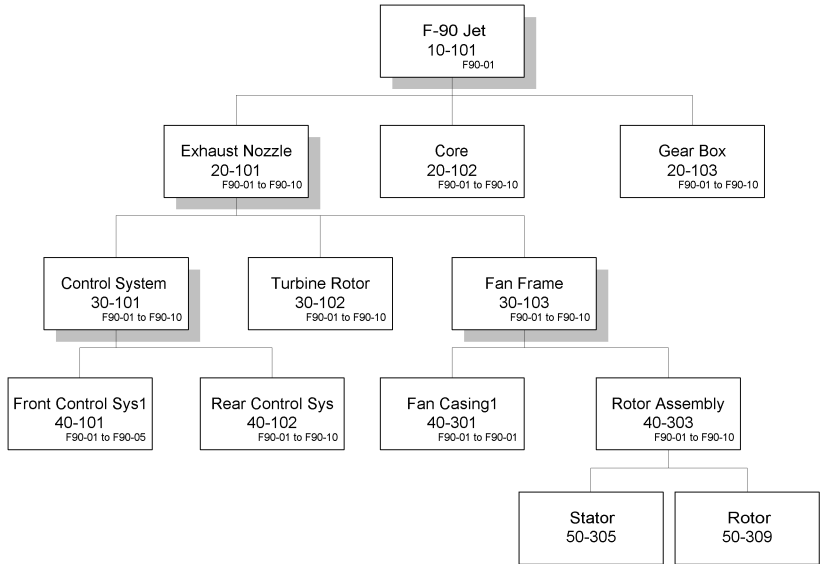

The configuration for a model/unit number of F90-06 will be as shown in Figure 14-3.

Figure 14–3 Bill of Material for F-90 Jet for Unit Number F90-06

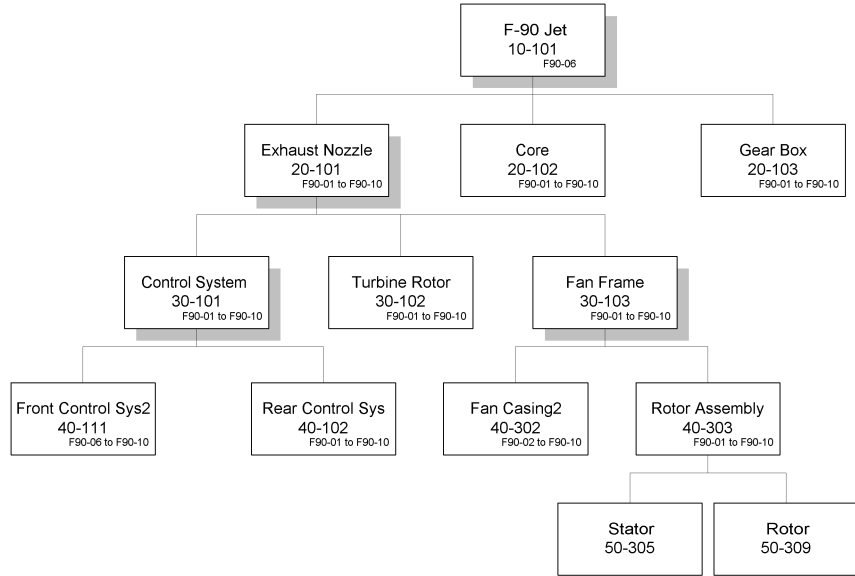

Multiple Model/Unit Number Ranges for the Same End Item

The prior example illustrates a single range of model/unit number (F90-01 to F90-10) to be effective for the end item 10-101, F-90 Jet, which is the most common configuration practice in the industry. You may also use multiple model/unit number ranges to be effective for the same end item. The following example illustrates how it can be accomplished.

Note: You can simplify your configuration process if you associate a different end item number or revision number with a different model/unit number range instead.

Figure 14-4 illustrates a graphical bill of a F97 jet (item number 10-110) defined for model/unit number range from F97A-01 to F97A-10, and another bill of the same end item F-97 for model/unit number range from F97B-01 to F97B-10. Again, all shaded boxes indicate that items are under model/unit effectivity control. Boxes without shading indicate that items are under date effectivity.

Figure 14-4 Model/Unit Effective Bill for F-97 Jet effective for Unit Numbers F97A-01 to F97A-10

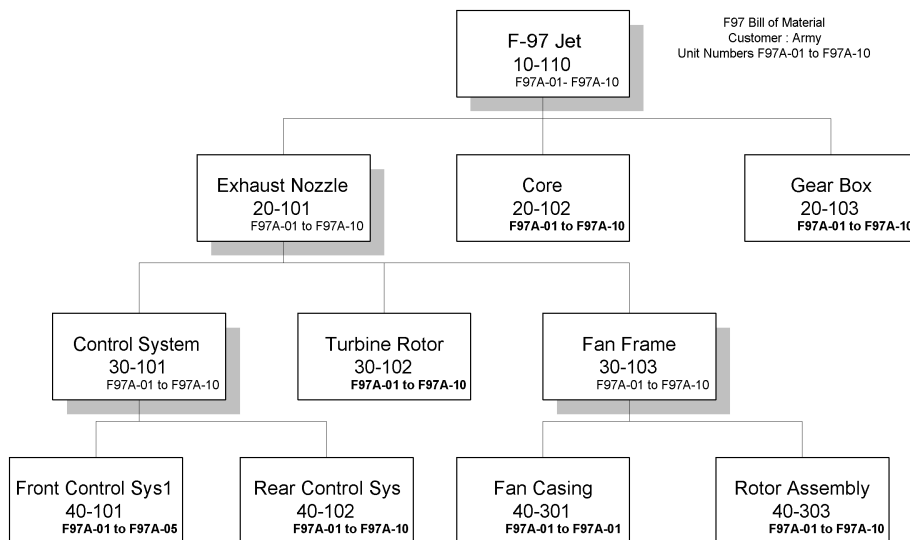
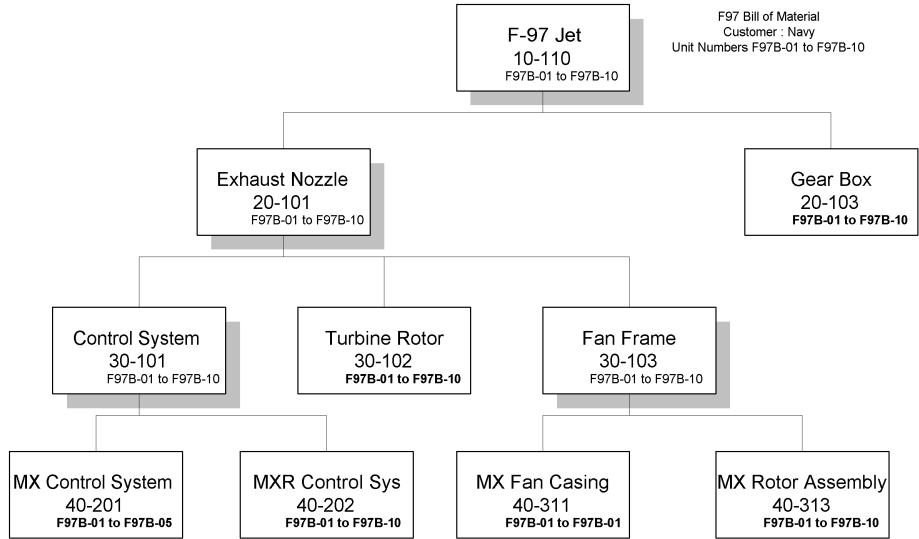

Figure 14-5 Model/Unit Effective Bill for F-97 Jet effective for Unit Numbers F97B-01 to F97B-10



Model/Unit Effectivity - Setup

Prerequisite

The only prerequisite for using model/unit effectivity features is that Oracle Project Manufacturing must be installed. Oracle Projects is not required for using model/unit effectivity.

Set Project Manufacturing Parameter - Allow Cross Unit Number Issues (Optional)

Unit effective components effective for one end item model/unit number can be issued to a WIP Job for an assembly with a different model/unit number if the Allow Cross Unit Number Issues checkbox is checked in the Project Manufacturing Parameters form

This is an optional setup step and as a default, the checkbox is not checked.

See Also

PJM Organization Parameters, *Oracle Project Manufacturing Users Guide*

Model/Unit Effectivity Features in Oracle Project Manufacturing

The following sections explain the model/unit effectivity specific features across all modules of Oracle Manufacturing. For more details on the base functionality for the features, refer to the respective product documentation.

Defining Model/Unit Effective items

Model/Unit effective items must be under Serial Control. The following two item attributes are important for model/unit effective items.

Serial Generation

The Serial Generation item attribute under the Inventory attribute group should be set to either Predefined or At Receipt for an item that is under model/unit effectivity control.

Effectivity Control

The Effectivity Control item attribute under the Bills of Material attribute group should be set to Model/Unit Number. You cannot have items that are both

model/unit effective and date effective at the same time. This item attribute can be set only at the master level.

The screenshot displays the 'Master Item (PM)' form in Oracle Project Manufacturing. The 'Organization' is set to 'PM Vision Project Mfg'. The 'Item' and 'Description' fields are empty. The 'Display Attributes' section has radio buttons for 'Master' and 'Org', with 'Master' selected. The 'Main' tab is active, showing various sub-tabs like 'Inventory', 'Bills ...', 'Costing', 'Purch...', 'Recei...', 'Physi...', 'Gener...', 'MPS/M...', 'Lead ...', and 'V'. The 'BOM Allowed' checkbox is unchecked. The 'BOM Item Type' dropdown is set to 'Standard'. The 'Base Model' field is empty. The 'Effectivity Control' dropdown menu is open, showing 'Date' and 'Model/Unit Number' options.

Note: Make sure that you choose the appropriate item attributes for model/unit effective items.

- ATP check for model/unit effective items is done at the item level. Model/unit numbers are ignored during an ATP check. The Allow ATP item attribute check box should not be checked for model/unit effective items.
 - ATO/PTO items cannot be model/unit effective.
 - You cannot change the Effectivity Control item attribute from Model/Unit Effectivity to Date Effectivity if you have on hand quantity for the item or if you have a bill defined for the item or if the item is a component of some other Bill.
 - You can have phantom items that are model/unit effectivity controlled. The same rules as other model/unit effective items that apply for bill definition apply for model/unit effective phantom items.
-

See Also

Item Attribute Description by Group, *Oracle Inventory User's Guide*

Generate and Maintain Model/Unit Numbers

Generate Model/Unit Numbers

The Generate Model/Unit Numbers concurrent request allows you to create model/unit numbers associated with a specific End Item Number. The model/unit number is an alpha-numeric field consisting of two parts

- an alpha-numeric prefix
- a number.

In situations where the model/unit number is composed of a model number and a number, the prefix will serve as a model number and the number will correspond to the numeric portion. The two parts will be concatenated and will serve as a single model/unit number for all manufacturing transactions. All the List of Values for unit number will display this concatenated model/unit number.

If the start and end numbers specified on the concurrent request have different number of digits, the smaller numbers will be left padded with zeros as shown in the following table.

Prefix	Starting Number	Count	Resulting Unit Numbers
A	1	10	A01 - A10
A	1	100	A001 - A100
A0	1	10	A001 - A010
A	1	9	A1 - A9

If the user generates model/unit numbers from A1 to A10 as described in the first example above, and subsequently requests generation of model/unit numbers from A1 to A100, the system will not re-generate the overlapping model/unit numbers. In this case the new request will only generate model/unit numbers from A11 through A100.

Model/unit numbers are unique across all items and organizations.

Maintain Model/Unit Numbers

You can maintain model/unit numbers using the End Item Model/Unit Numbers form in Project Manufacturing. For a specified end assembly, you can add comments against individual model/unit numbers or you can define a new model/unit number. You cannot update, delete, or disable previously created model/unit numbers.

Unit Number	Comment	

Bills of Material for Model/Unit Effective items

Define Model/Unit Effective Bills of Material

Users can have model/unit effective items at any level within the Bill of Material structure. The bill definition for model/unit effective items is governed by the following general rules:

- A model/unit effective item can either have another model/unit effective or a date effective item as its component
- A Date effective item cannot have a model/unit effective item as its component.

These general rules apply within the usual framework provided by Oracle Bills of Material.

The screenshot shows the Oracle Bills of Material (P2) window. At the top, the Item is 'MGD-TOP-1' and the description is 'Scr 17 MUNE - Top Assembly'. The UOM is 'Ea'. The Revision is 'A' and the Date is '13/SEP/2000 12:07:54'. The Display is set to 'Future and Current' and 'Implemented Only' is checked. Below the header are tabs for 'Main', 'Date Effectivity', 'Unit Effectivity', 'ECO', 'Component D...', 'Material Control', 'Order Entry', 'Shipping', and 'Comments'. The main area displays a table of components:

Item Seq	Operation Seq	Component	From	To
10	10	MGD-PO-2	AMGD01	AMGD34
10	10	MGD-PO-2	AMGD35	AMGD35
20	10	MGD-IO-1	AMGD01	AMGD10
30	10	MGD-PH-1	AMGD01	AMGD10
40	10	MGD-PO-3	AMGD01	AMGD01

At the bottom of the window are buttons for 'Substitutes', 'Designators', 'Elements', 'Bill Details', and 'Revision'.

All component items, including date effective component, within the bill of a model/unit effective item should be specified with valid model/unit numbers. You can define components of a model/unit effective item as effective for a single model/unit number or effective for a range of model/unit numbers.

You can enter the components as effective for any model/unit number that has been generated using the Generate Model/Unit Numbers concurrent request. It is not necessary that the model/unit number entered on the Bill of Material for an assembly be generated for that assembly.

Bills of Material for model/unit effective items can be copied with model/unit numbers.

See Also

Defining BOM, *Oracle Bills of Material User's Guide*

View Model/Unit Effective Bills of Material

You can view Bills for model/unit effective items using the Bills of Material form or the Indented Bills form. If you are using the Indented Bills form to view the bill for a model/unit effective assembly, you can also specify a range of Unit Numbers for which you want to view the Indented Bills of Material.

The screenshot shows the 'Find Indented Bills (P2)' window. It is divided into two main sections: 'Select' and 'Display'.
Select Section:
 - Item: MGD-TOP-1
 - Description: Scn 17 MUNE - Top Assembly
 - UOM: Ea
 - Current Revision: A
 - Latest Revision: A
 - Alternate: (empty field)
 - Revision: A
 - Date: 13/SEP/2000 12:09:13
 - Quantity: 1
 - Unit Number: (range field)
 - Levels: 10
 - Engineering Bill
Display Section:
 - Filter: Future and Current
 - Implemented Only
 - Order By: Operation Seq, Item Seq
 - Cgsts
 - Lead Time
 - Material Control
 - Use Planning %
 - Buttons: Clear, Find

You can choose to view the bill using the All, Current, and Current and Future option filters. For model/unit effectivity controlled items, the Current, and Current

and Future filters will show only the active components while the All filter will include the disabled components of unit effective bills as well.

The Unit Effectivity tab of the components region includes a new checkbox Disabled, which identifies the status of the unit effective component. This checkbox in the Bills of Material form can be updated only if the bill is for a model/unit effective item. The checkbox cannot be updated if the component is already disabled or if the component has pending engineering change orders (ECOs).

Routings for Model/Unit Effective Items

You cannot specify routings for model/unit effective items. Routings are currently defined only at the item level. All the model/unit numbers for a given item will have the same primary routing as defined for the item. However, you may define and use alternate routings if necessary.

Lead Time Roll-Up for Model/Unit Effective Items

You can also specify model/unit number at the time of Lead Time Rollup. The lead times rolled up from routings for different model/unit numbers will not vary because routings by model/unit number are not supported.

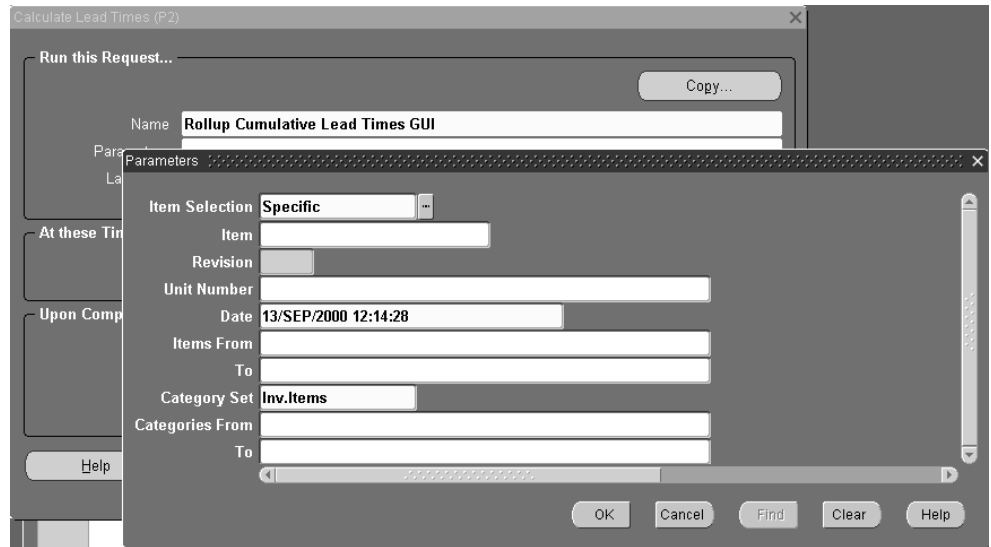

The screenshot shows a dialog box titled "Calculate Lead Times (P2)". The "Parameters" section is expanded, showing the following fields:

- Item Selection: **Specific**
- Item: [Empty text box]
- Revision: [Empty text box]
- Unit Number: [Empty text box]
- Date: **13/SEP/2000 12:14:28**
- Items From: [Empty text box]
- To: [Empty text box]
- Category Set: **Inv.Items**
- Categories From: [Empty text box]
- To: [Empty text box]

Buttons at the bottom of the dialog include: OK, Cancel, Find, Clear, and Help.

Bills of Material Open Interfaces

BOM open interfaces do not provide support for model/unit numbers.

Engineering Change Orders for Model/Unit Effective items

Engineering Change Orders for Model/Unit Effective Items

Users can create Engineering Change Orders for model/unit effective items. Engineering change orders for a model/unit effective item can be effective for a single model/unit number or for a range of valid model/unit numbers.

The screenshot displays a software window titled "Revised Items (P2) - P2-2003". The window contains a tabbed interface with tabs for "Main", "Item Details", "Dates", "Use Up Details", "Work In Process", "Cancel Details", and "Comments". The "Item Details" tab is active, showing a table with the following columns: "Item", "Alternate", "New Revision", "Effective Date", "From Unit Number", "Status", and "MRP Act". The first row of the table has the status "Open" and a checked checkbox in the "MRP Act" column. Below the table is an "Item Description" text field and three buttons: "History", "Revisions", and "Components".

Item	Alternate	New Revision	Effective Date	From Unit Number	Status	MRP Act
					Open	<input checked="" type="checkbox"/>
						<input type="checkbox"/>
						<input type="checkbox"/>
						<input type="checkbox"/>
						<input type="checkbox"/>
						<input type="checkbox"/>
						<input type="checkbox"/>
						<input type="checkbox"/>

In order to specify an ECO effective for a range of model/unit numbers, the From Unit Number field is populated in the Revised Items window of the Engineering Change Orders form and the To Unit Number is specified in the Revised Components window of the form.

Revised Components (P2) - P2-2003

Revised Item: **M17.IO.1** **Scn17 MUNE - Sub Assy - Inter Org Item**

Alternate:

From Unit Number: **AM1701**

Components

Main Item Details Component Details Material Control Order Entry Shipping Comments Cancel Details

Action	Component	Op Seq		Item Seq	UOM	Quantity	To Unit Number
		Old	New				
Add	CM10120	1	1	10	Ea	1	

Component Description: **PJM Test**

Substitutes Designators

If the ECO is effective for the entire range of unit numbers as specified in the bill of material and is updating or disabling the usage of the component, the disabled check box on the bill will be automatically checked for the component.

Scheduling Engineering Change Orders for Model/Unit Effective Items

You cannot specify an effective date on the ECO for a model/unit effective item. However, you can schedule ECOs for model/unit effective items using the Reschedule menu option from the Tools drop down menu. The scheduled ECOs will not be auto-implemented, and you will have to manually implement the ECOs.

Users should note that all pending ECOs for model/unit effective items will be considered by MRP/Supply Chain Planning for determining component requirements if the MRP Active checkbox on the ECO is checked.

ECOs for model/unit effective items will not affect WIP material requirements. You will have to manually update WIP material requirements after implementing an ECO for a model/unit effective item.

Mass changes to bills are not supported for model/unit effective items.

Changing Component Usage for a Partial Range of Model/Unit Numbers

You can create engineering change orders to be effective for a single model/unit number or for a range of model/unit numbers. If you change item usage for a partial range of model/unit numbers, you must create additional ECOs or manually update the bill of material of the assembly. However, if the engineering change order changes the entire unit number range as it appears on the bill or if it affects the tail end of the unit number range in the bill, you do not need to create additional ECOs. The following example illustrates the various cases involving ECOs for a partial range of model/unit numbers.

Figure 14–6 Examples of ECOs for Model/Unit Effective Assemblies

<p>A. ECO changing the tail end of the unit number range</p> <table border="1"> <thead> <tr> <th>Action</th> <th>Component</th> <th>From Unit Number</th> <th>To Unit Number</th> <th>Quantity</th> </tr> </thead> <tbody> <tr> <td>Change</td> <td>MU001</td> <td>U007</td> <td>U010</td> <td>2 Each</td> </tr> </tbody> </table> <p>B. ECO changing intermediate unit numbers of the unit number range</p> <table border="1"> <thead> <tr> <th>Action</th> <th>Component</th> <th>From Unit Number</th> <th>To Unit Number</th> <th>Quantity</th> </tr> </thead> <tbody> <tr> <td>Change</td> <td>MU001</td> <td>U005</td> <td>U007</td> <td>2 Each</td> </tr> <tr> <td colspan="5" style="text-align: center;">+</td> </tr> <tr> <th>Action</th> <th>Component</th> <th>From Unit Number</th> <th>To Unit Number</th> <th>Quantity</th> </tr> <tr> <td>Add</td> <td>MU001</td> <td>U008</td> <td>U010</td> <td>1 Each</td> </tr> </tbody> </table> <p>C. ECO changing initial unit numbers of the unit number range</p> <table border="1"> <thead> <tr> <th>Action</th> <th>Component</th> <th>From Unit Number</th> <th>To Unit Number</th> <th>Quantity</th> </tr> </thead> <tbody> <tr> <td>Change</td> <td>MU001</td> <td>U001</td> <td>U003</td> <td>2 Each</td> </tr> <tr> <td colspan="5" style="text-align: center;">+</td> </tr> <tr> <th>Action</th> <th>Component</th> <th>From Unit Number</th> <th>To Unit Number</th> <th>Quantity</th> </tr> <tr> <td>Add</td> <td>MU001</td> <td>U004</td> <td>U010</td> <td>1 Each</td> </tr> </tbody> </table>	Action	Component	From Unit Number	To Unit Number	Quantity	Change	MU001	U007	U010	2 Each	Action	Component	From Unit Number	To Unit Number	Quantity	Change	MU001	U005	U007	2 Each	+					Action	Component	From Unit Number	To Unit Number	Quantity	Add	MU001	U008	U010	1 Each	Action	Component	From Unit Number	To Unit Number	Quantity	Change	MU001	U001	U003	2 Each	+					Action	Component	From Unit Number	To Unit Number	Quantity	Add	MU001	U004	U010	1 Each	<p>Original bill of material</p> <table border="1"> <thead> <tr> <th>Component</th> <th>From Unit Number</th> <th>To Unit Number</th> <th>Quantity</th> </tr> </thead> <tbody> <tr> <td>MU001</td> <td>U001</td> <td>U010</td> <td>1 Each</td> </tr> </tbody> </table> <p>Resulting bill of material</p> <table border="1"> <thead> <tr> <th>Component</th> <th>From Unit Number</th> <th>To Unit Number</th> <th>Quantity</th> </tr> </thead> <tbody> <tr> <td>MU001</td> <td>U001</td> <td>U006</td> <td>1 Each</td> </tr> <tr> <td>MU001</td> <td>U007</td> <td>U010</td> <td>2 Each</td> </tr> </tbody> </table> <table border="1"> <thead> <tr> <th>Component</th> <th>From Unit Number</th> <th>To Unit Number</th> <th>Quantity</th> </tr> </thead> <tbody> <tr> <td>MU001</td> <td>U001</td> <td>U004</td> <td>1 Each</td> </tr> <tr> <td>MU001</td> <td>U005</td> <td>U007</td> <td>2 Each</td> </tr> <tr> <td>MU001</td> <td>U008</td> <td>U010</td> <td>1 Each</td> </tr> </tbody> </table> <table border="1"> <thead> <tr> <th>Component</th> <th>From Unit Number</th> <th>To Unit Number</th> <th>Quantity</th> </tr> </thead> <tbody> <tr> <td>MU001</td> <td>U001</td> <td>U003</td> <td>2 Each</td> </tr> <tr> <td>MU001</td> <td>U004</td> <td>U010</td> <td>1 Each</td> </tr> </tbody> </table>	Component	From Unit Number	To Unit Number	Quantity	MU001	U001	U010	1 Each	Component	From Unit Number	To Unit Number	Quantity	MU001	U001	U006	1 Each	MU001	U007	U010	2 Each	Component	From Unit Number	To Unit Number	Quantity	MU001	U001	U004	1 Each	MU001	U005	U007	2 Each	MU001	U008	U010	1 Each	Component	From Unit Number	To Unit Number	Quantity	MU001	U001	U003	2 Each	MU001	U004	U010	1 Each
Action	Component	From Unit Number	To Unit Number	Quantity																																																																																																									
Change	MU001	U007	U010	2 Each																																																																																																									
Action	Component	From Unit Number	To Unit Number	Quantity																																																																																																									
Change	MU001	U005	U007	2 Each																																																																																																									
+																																																																																																													
Action	Component	From Unit Number	To Unit Number	Quantity																																																																																																									
Add	MU001	U008	U010	1 Each																																																																																																									
Action	Component	From Unit Number	To Unit Number	Quantity																																																																																																									
Change	MU001	U001	U003	2 Each																																																																																																									
+																																																																																																													
Action	Component	From Unit Number	To Unit Number	Quantity																																																																																																									
Add	MU001	U004	U010	1 Each																																																																																																									
Component	From Unit Number	To Unit Number	Quantity																																																																																																										
MU001	U001	U010	1 Each																																																																																																										
Component	From Unit Number	To Unit Number	Quantity																																																																																																										
MU001	U001	U006	1 Each																																																																																																										
MU001	U007	U010	2 Each																																																																																																										
Component	From Unit Number	To Unit Number	Quantity																																																																																																										
MU001	U001	U004	1 Each																																																																																																										
MU001	U005	U007	2 Each																																																																																																										
MU001	U008	U010	1 Each																																																																																																										
Component	From Unit Number	To Unit Number	Quantity																																																																																																										
MU001	U001	U003	2 Each																																																																																																										
MU001	U004	U010	1 Each																																																																																																										

In case A, the ECO is effective for Unit Numbers U007 to U010 (tail end of the range). Here the ECO for changing the usage of the component from 1-each to

2-each will result in a bill as shown against the ECO. No additional changes are required.

On the other hand, in case B, the ECO is effective for an intermediate range of unit numbers (unit numbers U005 to U007). In such a case, you must create an additional ECO adding the same component for unit number U008 through U010. If the second ECO is not created, the effectivity of the components for unit numbers U008 through U010 will be lost. This also applies if you create an ECO effective for a single intermediate unit number.

Similarly, for case C, you must create an additional ECO effective for unit numbers U004 to U010, if you intend to retain the effectivity of component MU001 for these unit numbers. As with case B, this also applies if you create an ECO changing the usage of the first unit number in the range.

Note: You can manually update the bill of material for the model/unit effective assembly in the above cases. It is not necessary to create additional engineering change orders. This should be enforced as a user procedure when engineering change orders are created for model/unit effective items.

Disabling Components with Engineering Change Orders

You can disable components in the bill of material of a model/unit effective item. If the ECO is effective for an entire range of model/unit numbers as specified on the BOM, the original row in the bill is disabled. (The Disabled check box on the Bill of Material form will be checked).

When you disable the usage of a component, the To Unit Number from the bill of material defaults to the To Unit Number column of the ECO. You cannot change the To Unit Number when you are disabling a component via a ECO.

Order Management for Model/Unit Effective Items

Model/Unit Numbers on Sales Orders

For a model/unit effective item, you are required to enter a Unit Number on the sales order line (Other tab on the sales order entry form). The default behavior allows you to enter any valid model/unit number.

Sales orders cannot be entered for a range of model/unit numbers. Separate sales order lines for each model/unit number should be created if sales orders for a range of unit numbers need to be entered.

You can use model/unit effective items and date effective items on the same sales order. Model/unit numbers for ATO/PTO items are not supported.

Restricting Model/Unit Numbers at the Time of Sales Order Entry

You can restrict the list of values for Unit Numbers at the time of order entry using the extensible model/unit effectivity Demand Validation API. This API accepts the Order Category (regular orders versus internal orders), Item, Warehouse, and Unit Number as parameters and allows users to embed any validation logic as appropriate according to your unique business requirements.

See Also

Oracle Project Manufacturing Technical Reference Manual

Drop Shipment Support for Model/Unit Effective Items

Drop shipment functionality for model/unit effective items is similar to the functionality for date effective items. The purchase requisitions created from a sales order will carry the model/unit number specified on the sales order. The purchase order and the subsequent receiving transactions will use the model/unit numbers as entered on the sales order.

Order Import for Model/Unit Effective Items

The Import Orders concurrent request will import model/unit numbers on sales orders. Internal sales orders created after running the Create Internal Sales Order concurrent request in Oracle Purchasing is imported with the model/unit number information.

Return Material Authorizations with Model/Unit Numbers

Return Material Authorizations (RMAs) with model/unit numbers are also supported. The behavior of RMA receipts for Model/Unit effective items is the same as serial controlled items.

Planning of Model/Unit Effective Items

MDS/MPS Entries with Model/Unit Numbers

You specify a valid model/unit number on a master demand schedule or a master production schedule entry for a model/unit effective item. You cannot specify a range of model/unit numbers on a MDS or MPS entry.

Item Master Demand Schedule Entries (P2)

Schedule Inactive On

Show Version:

Item	IProject Number	Task Number	Unit Number	Line	Relie
<input type="checkbox"/>	<input type="text"/>	<input type="text"/>	<input type="text"/>	<input type="text"/>	<input type="checkbox"/>
<input type="checkbox"/>	<input type="text"/>	<input type="text"/>	<input type="text"/>	<input type="text"/>	<input type="checkbox"/>
<input type="checkbox"/>	<input type="text"/>	<input type="text"/>	<input type="text"/>	<input type="text"/>	<input type="checkbox"/>
<input type="checkbox"/>	<input type="text"/>	<input type="text"/>	<input type="text"/>	<input type="text"/>	<input type="checkbox"/>
<input type="checkbox"/>	<input type="text"/>	<input type="text"/>	<input type="text"/>	<input type="text"/>	<input type="checkbox"/>
<input type="checkbox"/>	<input type="text"/>	<input type="text"/>	<input type="text"/>	<input type="text"/>	<input type="checkbox"/>
<input type="checkbox"/>	<input type="text"/>	<input type="text"/>	<input type="text"/>	<input type="text"/>	<input type="checkbox"/>

Source Information

Origination Sales Order

Org Forecast/Schedule

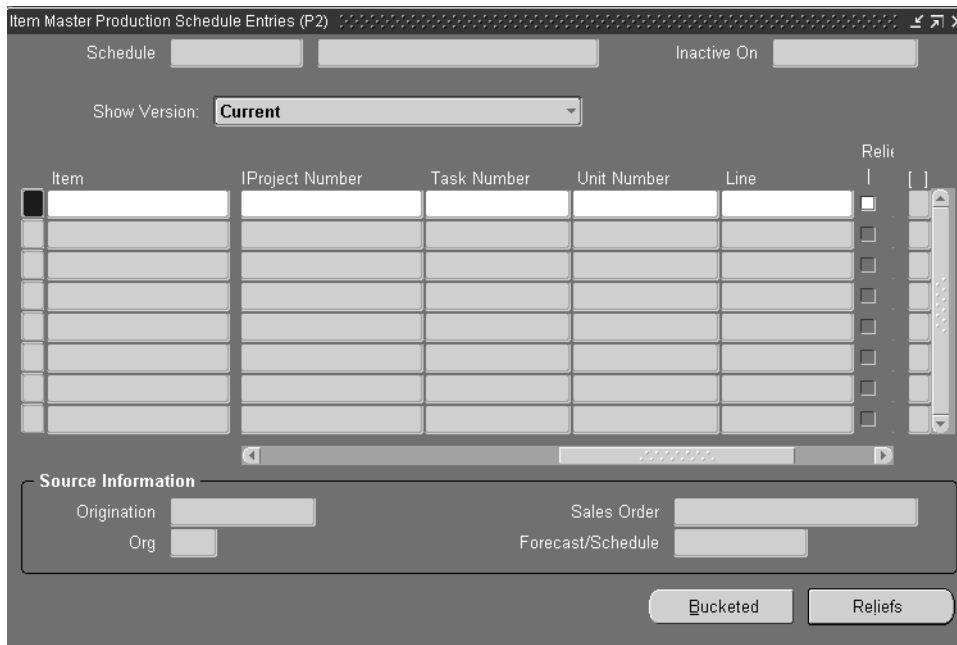

See Also

Oracle MRP Supply Chain Planning User Guide

Load/Copy/Merge schedules with Model/Unit Numbers

Loading an MDS or an MPS from sales orders will also load the model/unit number information for the item along with the other requisite details. The model/unit information is also retained during copying or merging two schedules.

See Also

Oracle MRP Supply Chain Planning User Guide

Netting by Model/Unit Numbers

Netting of supply and demand is handled by model/unit numbers for model/unit effective items. This netting follows the existing Project MRP netting logic and takes into account the item pegging attribute (hard and soft pegging), reservation level, and the hard pegging level plan options.

Note: Pending ECOs for model/unit effective items will be considered by MRP/Supply Chain Planning for determining component requirements, if the MRP Active checkbox on the ECO is checked.

Planner Workbench Features for Model/Unit Effective Items

The MRP/Supply Chain Planning Planner Workbench for MRP and MPS plans provides useful features for the planner to view, manage, and implement material plans for model/unit effective items. These features are:

- Supply/Demand can be searched for by model/unit number. Planners can search for supply and/or demand by model/unit number. The Find windows provide Unit Number as one of the search criteria for finding model/unit specific supply or demand.
- Model/unit number is displayed on the Planner Workbench: For model/unit effective items, the model/unit number is displayed on the Planner Workbench for both supply and demand records. The Unit Number column is a part of the folder form for the Planner Workbench. The Show Field option in the Folder

Tools displays the model/unit number if it is not already displayed on the Planner Workbench.

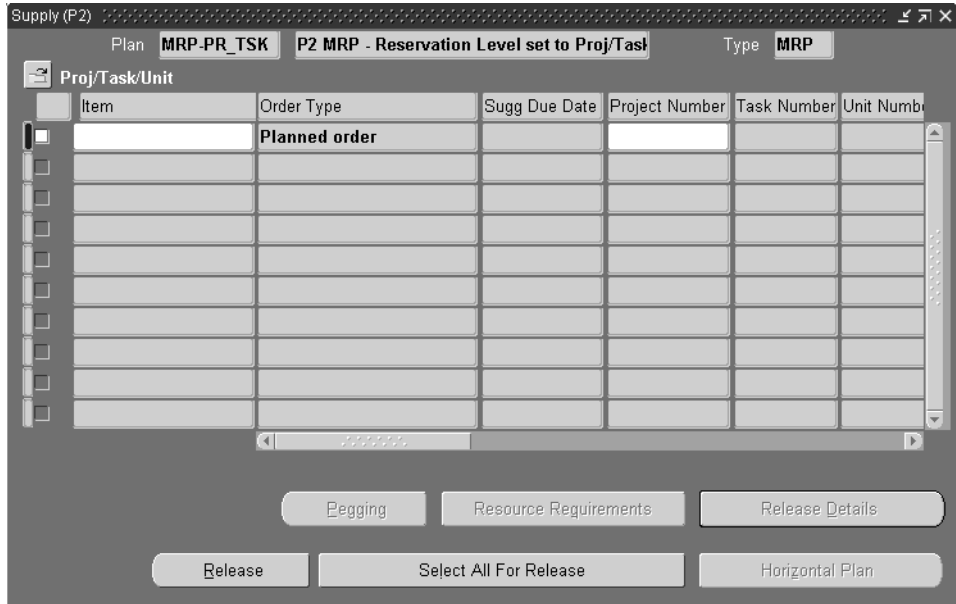

- Items window displays the Effectivity Control item attribute.
- Unit Number is displayed on the Implement Property Sheet.
- The pegging object navigator shows model/unit numbers.
- On-hand quantity is displayed by model/unit number.

Release Planned Orders with Model/Unit Numbers

Planned orders released from the MRP/Supply Chain Planning Planner Workbench carry the model/unit numbers on them. These planned orders, when converted into purchase requisitions or discrete WIP jobs, will carry the corresponding model/unit numbers. The Implement Property Sheet will display the model/unit number for the planned orders.

You can change the model/unit number on the Implement Property Sheet, if you to have a different model/unit number than suggested by the plan.

Order Modifiers with Model/Unit Effectivity

Order Modifiers for model/unit effective items apply at the item level and not at the model/unit number level. The planning engine will suggest planned orders by model/unit number for a given model/unit effective item based on the demand. The order modifiers are then applied at the item level. If there is an excess, the excess will be distributed among the various model/unit numbers in proportion to the demand for those model/unit numbers. This may result in fractional planned order quantities for model/unit effective items.

The following example illustrates the use of order modifiers for model/unit effective items.

Item: A001 Fixed Order Quantity = 30

Item	Unit Number	Demand Quantity
A001	U01	10.0
A001	U02	5.0
A001	U03	5.0

Assuming no on-hand for this item, this demand will result in the Planned Orders for 10, 5, and 5 for unit numbers U01, U02 and U03 respectively. The total quantity of item A001 for which planned orders are suggested (20) based on the demand is less than the Fixed Order Quantity (30) for the item. The planning engine will distribute the excess among the three unit numbers in proportion to their respective demands. It will suggest additional planned orders of 5 for unit number U01, and 2.5 each for unit numbers U02 and U03 respectively. This is shown in the following table:

Item	Unit Number	Planned Order Quantity	Remarks
A001	U01	10.0	Pegged to demand
A001	U02	5.0	Pegged to demand
A001	U03	5.0	Pegged to demand
A001	U01	5.0	Excess due to order modifiers
A001	U02	2.5	Excess due to order modifiers
A001	U03	2.5	Excess due to order modifiers

Total Order Quantity	30.0	Equals Fixed order Quantity
----------------------	------	-----------------------------

Forecast Entries for Model/Unit Effective Items

You cannot specify model/unit numbers on forecast entries.

Available to Promise for Model/Unit Effective Items

There is no ATP by model/unit numbers. ATP checks will be conducted only at the item level.

Planning Open Interfaces for Model/Unit Effective Items

The Planning Open Interfaces currently do not support model/unit numbers on schedule entries.

Model/Unit Numbers on Assignment Sets in Supply Chain Planning

You cannot specify model/unit numbers while defining Assignment Sets in Supply Chain Planning.

Procurement of Model/Unit Effective Items

Model/Unit Numbers on Purchase Requisitions

You can specify model/unit numbers on purchase requisitions. Model/unit numbers on requisitions are specified on the requisition distributions along with the project and task information. When a purchase order is created from the requisition, the purchase order will also carry the model/unit number. You must specify a valid model/unit number on the requisition for model/unit effective items.

The screenshot shows the 'Distributions (Vision Project Mfg) - [New]' window. It has two tabs: 'Accounts' and 'Project'. The 'Project' tab is active, and the title bar indicates the current view is 'Expenditure'. Below the tabs is a table with the following columns: Num, Type, Org, Date, Quantity, and Unit Number. The first row of the table has the value '1' in the 'Num' column and '10' in the 'Quantity' column. Below the table is a section titled 'Account Description' with four input fields: 'Charge', 'Accrual', 'Budget', and 'Variance'.

Num	Type	Org	Date	Quantity	Unit Number
1				10	

Account Description

Charge		Budget	
Accrual		Variance	

Model/Unit Numbers on Purchase Orders

You can specify model/unit numbers on purchase orders in the PO distribution. Entering a model/unit number is mandatory for model/unit effective items. The

model/unit number on a PO distribution becomes the model/unit number for the item being received.

Num	Type	Org	Date	Quantity	Unit Number
1				20	

Account Description

Charge: Vision Project Manufactur.San Diego P Budget:

Accrual: Vision Project Manufactur.San Diego P Variance: Vision Project Manufactur.San Diego P

Model/Unit Numbers on Blanket Releases

You can create blanket releases for model/unit effective items by specifying model/unit number on the purchase release distribution. The blanket purchase agreement, however, will be only at an item level. You cannot specify model/unit number on blanket purchase agreements.

Model/Unit Numbers on RFQs and Quotes

The Request for Quote and Quotations feature does not support model/unit numbers. The model/unit number can be either be conveyed as an attachment to the RFQ or as a note to the supplier.

Model/Unit Numbers on Internal Requisitions and Internal Sales Orders

You must specify model/unit numbers on internal requisitions of model/unit effective items. The model/unit number will also be carried forward to the internal sales orders created from these internal requisitions.

Store, Track, and Manage Inventory of Model/Unit Effective Items

Receiving Transactions for Model/Unit Effective Items

Model/unit numbers on the purchase order will be automatically assigned to the items at the time of receipt. The model/unit number on the purchase order will be associated with the appropriate serial numbers of the received items at receipt time. If project/task information is also specified on the purchase order/blanket release, receipt transaction should be done to the appropriate project locator. The project/task information will default from the purchase order or blanket release distribution line.

Miscellaneous Receipts for Model/Unit Effective Items

You can process Miscellaneous Receipt transactions for model/unit effective items, but you cannot specify model/unit numbers on the transaction itself. After a Miscellaneous Receipt transaction, you must manually associate the model/unit number with the item serial numbers entered on the transaction in the Unit Number tab of the Serial Numbers form in Inventory.

Serial	Item	Unit Number
P000000050054	MGD-PO-5	BMGD04
P000000050055	MGD-PO-5	BMGD04
P000000050056	MGD-PO-5	BMGD04
P000000050057	MGD-PO-5	BMGD04
P000000050058	MGD-PO-5	BMGD04
P000000050059	MGD-PO-5	BMGD04
P000000050060	MGD-PO-5	BMGD04
P000050001	MGD-PO-5	AMGD04
P000050002?zð	MGD-PO-5	AMGD04
P00050041	MGD-PO-5	BMGD04

Item Description: **Scn 17 MUNE - Purchased Item**

Buttons: View Genealogy, Transactions

If model/unit numbers are not specified for the corresponding item serial numbers, the Unit Number field will be null. If the Allow Cross Unit Number Issues checkbox is checked in the Project Manufacturing Parameters form, these serial numbers could be issued to a WIP job, and will result in a loss of model/unit number information. Assigning model/unit numbers to Miscellaneous Receipt transactions should therefore be enforced as a user procedure.

Miscellaneous Issues for Model/Unit Effective Items

As with Miscellaneous Receipt transactions, you cannot specify a model/unit number on the Miscellaneous Issue transaction of model/unit effective items. The on hand for the appropriate model/unit number will be decremented from inventory based on the serial number information entered on the Miscellaneous Issue transaction. You must ensure that you enter the correct serial numbers for the transaction so that the appropriate model/unit numbers are transacted.

Subinventory Transfers for Model/Unit Effective Items

Subinventory transfers for model/unit effective items can be made similar to date effective items. You can process a common to common, common to project and project to project subinventory transfer for model/unit effective items and the unit number information will be maintained for the items transacted.

Note: Project related subinventory transfers can be done using the Project Transfer Transaction Type in the Project Transfer form.

OnHand for Model/Unit Effective Items

You can view onhand quantities for model/unit effective items using the OnHand Quantities form in Inventory. The Detailed OnHand Quantities window allows users to display the serial numbers for the onhand quantities. The model/unit

number for the items on hand are also displayed along with the serial number information.

The screenshot displays the 'On-hand Quantities (P2)' form in Oracle Inventory. The main window shows the item 'MGD-PO-5' with a description 'Scn 17 MUNE - Purchased Item' and a UOM of 'Ea'. A 'Detailed On-hand Quantities (P2)' window is open, showing a table of on-hand quantities across different subinventories and locators. Below this, a 'Serial On-hand Quantities (P2) - MGD-PO-5' window is open, showing a list of serial numbers and their corresponding unit numbers. The 'Total Quantity' is displayed as 22.

<3>Organization	<3>Item	<3>Subinventory	<3>Re	<3>UC	<3>Locator	<3>On-hand Qty
P2	MGD-PO-5	Stores		Ea	xxx-5-5--	22
P2	MGD-PO-5	Stores				

Serial	Unit Number
PO000000050061	CMGD01
PO000000050062	CMGD01
PO000000050063	CMGD02
PO000000050003	AMGD05
PO000000050004	AMGD05
PO000000050005	AMGD05
PO000000050006	AMGD05
PO000000050007	AMGD05

Total Quantity: 22

Viewing Supply/Demand for Model/Unit Effective Items in Inventory

You can only view the Item Supply/Demand information in Inventory by item number. For model/unit effective items, the model/unit numbers are not displayed on the form.

Transfer OnHand from One Model/Unit Number to Another

You can transfer model/unit effective items from one unit number to another by updating the model/unit number that is associated with the serial number when the serial number resides in stores. This is done by changing the model/unit number in the Unit Number tab of the Serial Numbers form in Inventory. Access to

this function should be restricted by function security. The changes to model/unit numbers are captured in an audit trail.

Note: The OLD_UNIT_NUMBER column in PJM_UNIT_SERIAL_HISTORY table stores the previous model/unit number for the item.

See Also

Oracle Project Manufacturing Technical Reference Manual

Model/Unit Numbers on Intransit Shipments

Model/unit numbers are maintained for intransit shipments between two inventory organizations. When the intransit shipment is received into the destination organization, the on hand quantity for the appropriate model/unit number is automatically incremented.

View Genealogy for Model/Unit Effective Items

You can view the model/unit numbers on the genealogy for inventory transactions. The model/unit number information is displayed in the Properties section of the Tree Navigator window for model/unit effective items. This feature can be accessed from the View Genealogy button on the Serial Numbers form.

WIP Features for Model/Unit Numbers

Discrete Jobs for Model/Unit Effective Items

You must enter a valid model/unit number on discrete WIP jobs for model/unit effective items. The unit number can be entered in the Schedule Group, Project tab of the Discrete Jobs form.

The screenshot displays the 'Discrete Jobs (P2)' form. The top section contains fields for Job (WIP29952), Assembly (MGD-TOP-2), Class (WIP-MU), Status (Released), Type (Standard), UOM (Ea), and Firm (unchecked). Below this are 'Quantities' (Start: 10, MRP Net: 10) and 'Dates' (Start: 30/AUG/2000 00:00:00, Completion: 01/SEP/2000 11:00:00). The 'Schedule Group, Project' tab is active, showing fields for Schedule Group, Line, Project (MGD-MU-SYS), Task (5.0), Unit Number (BMGD07), Build Seq, and Model/Unit test (Installation). Navigation buttons for Sales Orders, Operations, and Components are at the bottom.

Model/Unit Numbers on Repetitive Schedules

Model/unit numbers on Repetitive Schedules are not supported.

Exploding WIP Material Requirements by Model/Unit Number

For a discrete job for a model/unit effective item, WIP material requirements will be determined based on the end item unit number specified on the discrete job. The material requirements will be displayed in the Material Requirements and the View Material Requirements forms.

WIP Completions for Model/Unit Effective Items

At the time of WIP completion, you must specify the serial number information for model/unit effective items. The model/unit number specified on the WIP job will automatically be assigned to the completed assemblies at the time of WIP completion. If project/task information is also specified on the WIP Job, the WIP completions must be done to the appropriate project locator. The project/task information will default from the WIP job header.

WIP Component Issues and Backflush for Model/Unit Effective Items

You can view the model/unit number of a model/unit number effective item at the time of issue to a job. The model/unit number can be viewed as part of the list of values for serial numbers for model/unit effective items. The model/unit number along with its serial number will also be recorded as the serialized component is issued or backflushed to the job.

As a default behavior, if a component is under model/unit number effectivity control, you may issue to a parent assembly with the same model/unit number.

Component Issues Across Different Model/Unit Numbers

You can also allow issue of a model/unit effective component to a WIP job with a different model/unit number. This is permitted if the checkbox for the Project Manufacturing parameter Allow Cross Unit Number Issues is checked.

Figure 14–7 Cross Unit Number Issue Example

Figure 14-5 illustrates the example for cross unit number issue. Both items A and B are under model/unit effectivity control. Item B with unit number FAN-538446 is required for parent item B with unit number FAN-538446. Suppose the component B with FAN-538446 is delayed due to shortage or quality problem, while another component B with FAN-538447 is available. Based on Project Manufacturing parameter Allow Cross Unit Number Issue, you can issue component B with FAN-538447 to the WIP job for assembly A with FAN-538446.

When you select a component with a unit number that is different from its parent assembly, you will receive a warning message. You need to confirm that you would like to proceed. Irrespective of the cross unit number issues, you must still ensure that it passes current project/task validation logic if the WIP job is associated with a project/task.

The list of values of model/unit effective components that you can issue to a WIP job will change based on the Project Manufacturing parameter Allow Cross Unit Number Issues. If the checkbox for the parameter is checked, you can view and issue all components of the same item across unit numbers. If it is not checked, you can view and issue only components of the exact same unit number as specified on the WIP job of the parent assembly.

For WIP material transactions that are imported through transaction interface, the end item unit number validation will be based on the Project Manufacturing parameter Allow Cross Unit Number Issues.

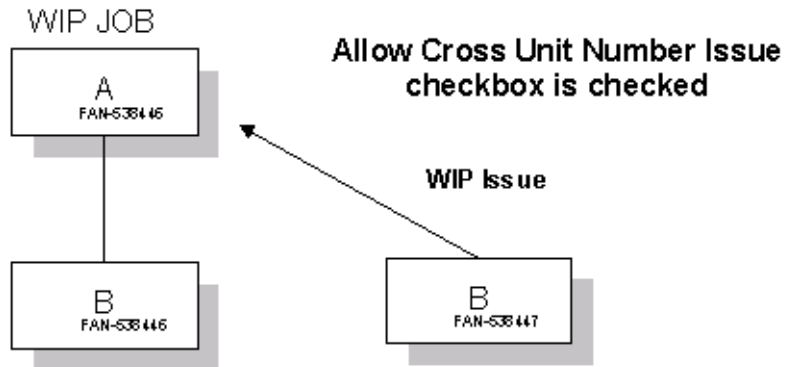
Note: Project Manufacturing parameter Allow Cross Unit Number Issues can affect user interface behavior, such as different list of values and different validation logic triggered from user navigation.

Work Order-less Completions for Model/Unit Effective Items

You must specify a valid model/unit number on work orderless completions of model/unit effective items. The model/unit number on the work orderless completion transaction will be automatically assigned to the assembly serial numbers completed. Appropriate quantities of component items will be backflushed from inventory.

Like discrete job issues and backflush transactions, the Project Manufacturing parameter Allow Cross Unit Number Issues will also govern the backflushing of serialized model/unit effective components from inventory.

Flow Manufacturing Support for Model/Unit Numbers

Model/Unit Numbers on Flow Schedules

You can create flow schedules for model/unit effective items similar to date effective items. The model/unit numbers on planned orders or sales order lines will be automatically transferred to the flow schedules. The model/unit number is displayed on the flow schedules.

Model/Unit Numbers on Kanbans

Model/unit numbers on Kanbans are not supported.

See Also

Flow Schedules, *Oracle Flow Manufacturing User's Guide*

Work Orderless Completions for Model/Unit Effective Items, *Oracle Work in Process User's Guide*

Shipping of Model/Unit Effective Items

The pick release process will pick up items with the same model/unit number as the sales order line item. If project and/or task are specified on the Sales Order line, the pick release process will pick up items from the corresponding project/task locator with the appropriate model/unit number.

Like with all serial controlled items, ship confirm of Model/Unit effective items uses the Move Order Transactions form for shipping of Model/Unit effective items. At the time of ship confirm, the list of values for serial numbers will show only the serial numbers specific to the model/unit number entered on the sales order line. You cannot ship an item with a model/unit number different than that mentioned on the sales order line.

Model/Unit Numbers on Pick Slip, Pack Slip, and Other Shipping Reports

The model/unit number for an item does not appear on the Pick Slip, Pack Slip, or any other shipping reports.

Implementation Notes

The following features related to model/unit effectivity have not been implemented in the current release. Where applicable, the feature will be implemented in future releases.

Costing at Item Level and not Model/Unit Number Level

Item costs are always maintained at the Item level. For model/unit effectivity controlled items, item costs cannot be viewed at the model/unit number level.

Model/Unit Effectivity Support for Discrete and Flow Manufacturing Only

Model/unit effectivity features are only supported in Discrete and Flow Manufacturing environments. There is no model/unit effectivity support in repetitive manufacturing.

No Reports by Model/Unit Numbers

No reports show the model/unit numbers.

ATO/PTO Items Cannot be Model/Unit Effectivity Controlled

Model/unit effectivity features do not apply for ATO/PTO items.

No Model/Unit Effective Routings

You cannot specify routings for model/unit effective items. Routings are currently defined only at the item level. All the model/unit numbers for a given item will have the same primary routing as defined for the item. You may, however, define and use alternate routings if necessary.

Lead Time Roll-Up for Model/Unit Effective Items

You can also specify model/unit number at the time of Lead Time Rollup. The lead times rolled up from routings for different model/unit numbers will not vary because routings by model/unit number are not supported.

Bills of Material Open Interfaces Do Not Support Model/Unit Numbers

BOM open interfaces do not provide support for model/unit numbers.

Engineering Change Orders for Model/Unit Effective Items Cannot be Auto-Implemented

The scheduled ECOs for model/unit effective items will not be auto-implemented, you will have to manually implement the ECOs.

Cannot Mass Change Bills of Material for Model/Unit Effective Items

You cannot process a mass change Bill of Material for a model/unit effective item.

No Return Material Authorizations Support with Model/Unit Numbers

Return Material Authorizations (RMA) with model/unit numbers are not supported.

Forecast Entries at Item Level only

You cannot specify model/unit numbers on forecast entries. Forecast entries can therefore be entered only at the item level.

No Available to Promise for Model/Unit Effective Items

There is no ATP by model/unit number. ATP checks will be conducted only at the item level.

Planning Open Interfaces Do Not Support Model/Unit Numbers

The Planning Open Interfaces currently do not support model/unit numbers on schedule entries.

No Model/Unit Numbers on Assignment Sets in Supply Chain Planning

You cannot specify model/unit numbers along with item numbers while defining assignment sets in Supply Chain Planning.

Request For Quotations and Quotations can be Entered Only at Item Level

The Request for Quotations and Quotations feature does not support model/unit numbers. The model/unit number can be either conveyed as an attachment to the RFQ or as a note to the supplier.

Kanban Planning at Item Level Only

Model/unit numbers on kanbans are not supported.

No Model/Unit Numbers on Pick Slip, Pack Slip, and Other Shipping Reports

The model/unit number for an item does not appear on the Pick Slip, Pack Slip, or any other shipping reports.

Web Workbench

This chapter describes how to use the Web Workbench for querying project data. The following topics are included:

- Viewing Project Details
- Inquiry Details for Projects Inquiry (Projects Only)
- Inquiry Details for Projects Inquiry (with Projects)
- Inquiry Details for Projects Inquiry (without Projects)

Overview

You can use this workbench to analyze Oracle Projects and Oracle Project Manufacturing data. The Web Workbench provides three modes based on the Oracle applications available and includes a project kiosk and a task kiosk, and you can drill down to the project or project and task details from the two kiosks respectively. You can also drill down to the selected transactional details in this workbench. This inquiry provides you with access to all project information.

In the Web Workbench, you can search for a project using project number, project name, project description, or any of the criteria listed on page 15-4.. You can then drill to the details for a project from the list of projects that matched your search criteria. The following information is provided for each project: project number, project name, project description, project type, start date, project status, end date, category, and organization name.

In the Project Kiosk, you can view the project information and drill down to review additional details for the project including budgets, expenditures, project status, RFQ, quotation, requisitions, purchase orders, blanket POs, manufacturing plans, WIP jobs, onhand balances, sales orders, onhand values, and flow schedules. All inquiries in the project kiosk will display the project header information and includes project number, project name, project description, project type, start date, project status, end date, category, and organization name.

In the Task Kiosk, you can view the task information and then drill down to review details for your project or project and task. Available details include RFQs, quotations, requisitions, purchase orders, blanket POs, manufacturing plans, WIP jobs, onhand balances, sales orders, onhand values, and line schedules. All inquiries in the Task Kiosk will display the task header information including project number, project name, project description, task number, task name, manager, task start date, and task end date.

Viewing Project Details

Prerequisites

Items are based on Profiles defined in Oracle Projects because of the many-to-many relationship of Budget Types to Budget Amounts. Before you can use the Web Workbench, the following profile names must be defined in the System Administrator responsibility at the Site level:

- PA: Reporting Budget 1 (Cost) (*Default: Approved Cost Budget*)

- PA: Reporting Budget 2 (Cost) (*Default: Forecasted Cost Budget*)
- PA: Reporting Budget 3 (Revenue) (*Default: Approved Revenue Budget*)
- PA: Reporting Budget 4 (Revenue) (*Default: Forecasted Revenue Budget*)

For more information on the profile options, see *Oracle Projects User's Guide*.

►► To launch the workbench

1. Select one of the following methods:
 - Navigate to the Web Workbench from the Navigator menu in Oracle Applications or
 - Use the web browser through the self service applications.

If you enter through the web browser you will need to provide a username and password to log into the system. Then select the Project Manufacturing Inquiry option.
2. Select the mode desired.
 - Project Inquiry (with Projects)

With this mode, you can drill down to all Oracle Projects and Oracle Project Manufacturing information for a particular project.
 - Project Inquiry (without Projects)

With this mode, you can drill down to all Oracle Project Manufacturing information for a particular Seiban number.
 - Project Inquiry (Projects only)

With this mode, you can drill down to all Oracle Projects and procurement information for a particular project. This mode is designed specifically for Project inquiry without Project Manufacturing.
3. Select the search criteria. The following search criteria are available by default for each mode.
 - **Project Inquiry (Projects only)**
 - Project Number
 - Project Name
 - Project Description
 - Manager Name

- Project Status
- PM Product
- PM Project Reference
- Project Organization Name
- Project Type
- **Project Inquiry (with Projects)**
 - Project Number
 - Project Name
 - Project Description
 - Manager Name
 - Project Status
 - PM Product
 - PM Project Reference
 - Project Organization Name
- **Project Inquiry (without Projects)**
 - Project Number
 - Project Name
 - Operating Unit

Once you have selected a project from the list of projects that matched your search criteria you can drill down for details.

Inquiry Details for Project Inquiry (Projects Only)

By default, the following information is provided for each project: project number, project name, start date, completion date, manager name, project status, project organization name, project type, PTD revenue, PTD cost, PTD margin, YTD revenue, cost, YTD margin, YTD margin percentage, YTD revenue, YTD cost, YTD margin, YTD margin percentage, total revenue budget, backlog, backlog percentage, commitments, total cost.

The calculations for the displayed columns are as follows:

PTD Margin = PTD Revenue - PTD Burdened Cost

PTD Margin % = PTD Margin / PTD Revenue

ITD Margin = ITD Revenue - ITD Burdened Cost

ITD Margin % = ITD Margin / ITD Revenue

YTD Margin = YTD Revenue - YTD Burdened Cost

YTD Margin % = YTD Margin / YTD Revenue

Backlog = Primary Budgeted Revenue Amount - ITD Revenue (if ITD revenue is > Primary Budgeted revenue amount then backlog = 0)

Backlog % = Backlog / Primary Budgeted Revenue Amount

Total Cost = Total Cost ITD + Committed Burden Amount

Each business can select columns to be shown in the Workbench by changing the display mode for the column in the PJM_PROJECT_PRJ_SUMMARY_V. *Please refer to the Project Manufacturing TRM for the complete listing and additional details.*

Note: The formula for calculating the project margin is based on **burdened cost**, not **cost of goods sold**. If your project has incurred cost for which you have not yet recognized revenue, the margin calculation will be incorrect. For example, if you have a project to manufacture items which require a year to build and you plan to recognize revenue on a percentage completion basis as cost is incurred, the margin calculation for this project will be correct. If, however, you plan to recognize revenue at the time of shipment, your project will have incurred cost and no revenue for eleven months. The margin for this project will be a negative number, which is incorrect. We recommend that you do not use this column for project manufacturing projects.

Project Kiosk in Project Inquiry (Projects only)

In the Project kiosk, you can view the project information and you can then choose to drill down to review additional details for the project including expenditures, commitments, RFQ, quotation, requisitions, purchase orders, and blanket POs. You can also choose to drill down to the task kiosk/task level details by selecting a task number in the task summary which includes a list of valid tasks for a project. The task summary contains details on the task number, task name, description, manager, start date and end date. All inquiries in the project kiosk will display the project header information and includes project number, project name, project description, project type, start date, project status, end date, category, and organization name.

Task Kiosk in Project Inquiry (Projects only)

In the task kiosk, you can view the task information and then choose to drill down to review details for your project/task including RFQ, quotation, requisitions, purchase orders, and blanket POs. All inquiries in the task kiosk will display the task header information including project number, project name, project description, task number, task name, manager, task start date, and task end date.

Inquiry Details for Project Inquiry (with Projects)

By default, the following information is provided for each: project number, project name, start date, completion date, manager name, project status, project organization name, project type, PTD revenue, PTD cost, PTD margin, YTD revenue, cost, YTD margin, YTD margin percentage, YTD revenue, YTD cost, YTD margin, YTD margin percentage, total revenue budget, backlog, backlog percentage, commitments, total cost.

The calculations for the displayed columns are as follows:

PTD Margin = PTD Revenue - PTD Burdened Cost

PTD Margin% = PTD Margin / PTD Revenue

ITD Margin = ITD Revenue - ITD Burdened Cost

ITD Margin% = ITD Margin / ITD Revenue

YTD Margin = YTD Revenue - YTD Burdened Cost

YTD Margin% = YTD Margin / YTD Revenue

Backlog = Primary Budgeted Revenue Amount - ITD Revenue (if ITD revenue is > Primary Budgeted revenue amount then backlog = 0)

Backlog% = Backlog / Primary Budgeted Revenue Amount

Total Cost = Total Cost ITD + Committed Burden Amount

Note: Each business can select columns to be shown in the Workbench by changing the display mode for the column in the PJM_PROJECT_PRJ_SUMMARY_V. *Please refer to the Project Manufacturing TRM for the complete listing and additional details.*

Project Kiosk in Project Inquiry (with Projects)

In the project kiosk, you can view the project information and you can drill down to review additional details for the project including expenditures, commitments, RFQs, quotations, requisitions, purchase orders, blanket POs, manufacturing plans, WIP-jobs, onhand balances, sales orders, onhand values, and line schedules.

You can also drill down to the task kiosk/task level details by selecting a task number in the task summary which includes a list of valid tasks for a project. The task summary contains details on the task number, task name, description, manager, start date and end date. All inquiries in the project kiosk will display the project header information and includes project number, project name, project description, project type, start date, project status, end date, category, and organization name.

Task Kiosk in Project Inquiry (with Projects)

In the task kiosk, you can view the task information and then drill down to review details for your project/task including RFQ, quotation, requisitions, purchase orders, blanket POs, manufacturing plans, WIP jobs, onhand balances, sales orders, and line schedules. All inquiries in the task kiosk will display the task header information including project number, project name, project description, task number, task name, manager, task start date, and task end date.

Inquiry Details for Project Inquiry (without Projects)

The following information is provided for each project in the workbench: project number, project name, operating unit.

Seiban Kiosk in Project Inquiry (without Projects)

In the seiban kiosk, you can view the project information and you can then choose to drill down to review additional details for the project including RFQ, quotation, requisitions, purchase orders, blanket POs, manufacturing plans, WIP jobs, onhand balances, sales orders, onhand values, and line schedules. All inquiries in the seiban kiosk will display the project header information and includes project number, project name, project description, project type, start date, project status, end date, category, and organization name.

Column Details on Drilldowns

The following paragraphs list the column details for each drilldown for a project or task in the Web Workbench.

Expenditures

▶▶ To view expenditures for a project

- Select the expenditures button in the project kiosk.

The following information is displayed: task number, expenditure type, expenditure category, revenue category code, expenditure organization, item date, quantity, burdened cost, accrued revenue, bill amount, non labor resource, non labor resource organization, UOM, employee name employee number, job name, and supplier name.

Commitments

▶▶ To view project commitments

- Select the commitments button in the project iiosk for the selected project.

The following information is displayed: task number, task name, commitment number, commitment line number, expenditure type, expenditure organization, commitment date, quantity, UOM, commitment amount, burdened cost, commitment type, requester, buyer, need by date, promised date, approved?, approved date, description, supplier, transaction source, denom currency code, denom raw cost, denom burdened cost, acct currency code, acct raw cost, acct burdened cost, acct rate date, acct rate type, acct exchange rate, receipt currency code, receipt currency amt, receipt exchange rate, project currency code, project rate date, project rate type, project exchange rate, commitment rejection code.

Purchase Orders

▶▶ To view project purchase orders

1. Select the purchase orders button in the Project/Task/Seiban kiosk.

Purchase order summary includes the following information for each project purchase order: document type, revision number, revised date, order date, status, supplier, supplier site, ship-to location, currency, amount, ship via, freight term, FOB, buyer, bill-to location, payment term, item number, item description, end item model/unit number.

2. Select a purchase order to view line, receipt, and invoice details.

»» To view project purchase order details

1. Select the purchase order in the Project PO window.

For each project purchase order, you can view the following details: item number, supplier item number, description, price, quantity ordered, quantity received, quantity invoiced, ship-to location, status, UOM, and promise date.

2. Select the appropriate button in the purchase order detail window to view the receipt or invoices for the purchase order. See: *Oracle Internet Procurement User's Guide*

»» To view matched invoices for a project purchase order (Non PJM)

- Select the invoices button in the purchase order detail window.

The following information is displayed: invoice number, invoice date, due date, amount due, payment number, and payment status. You can choose a specific invoice to drill to the invoice summary window. The information displayed includes: invoice number, date, due date, currency, gross amount, amount due, discount date, available discount, PO number, payment number, and description. You can review receipts for this purchase order by selecting the receipts button in the invoice window.

»» To view project purchase order receipts (Non PJM)

1. Select the receipt button in the purchase order detail window.

The following information is displayed for each receipt transaction: receipt number, receipt date, PO number, item number, description, supplier item number, supplier, quantity received, UOM, packing slip, and supplier lot.

2. You can view matched invoices for the purchase order by selecting the invoices button in the PO receipt transaction window.

Requisitions**»» To view project requisitions**

1. Select the requisitions button in the Project/Task/Seiban kiosk.

The following information is displayed: requisition number, creation date, description, type, approval status, approver, closed flag, cancelled flag, preparer, currency, total, item number, item description, and end item model/unit number.

2. Select the attachments button to view any existing attachments for the project requisition.
3. You can drill down further to the line and distribution level details for each requisition in the workbench.

Quotations

▶▶ To view project quotations

- Select the quotations button in the Project/Task/Seiban kiosk.

The following information is displayed: quotation number, quotation type, quotation class, quotation status, Request For Quotation (RFQ) number, effective date, expiration date, supplier and buyer.

RFQs

▶▶ To view project RFQs

1. Select the RFQ button in the Project/Task/Seiban kiosk.

The following information is displayed: RFQ number, status, buyer, reply date, and close date.

2. Choose the desired options to drill down to view the details for each RFQ.

Blanket POs

▶▶ To view blanket POs for your project

- Select the blanket POs button in the Project/Task/Seiban kiosk.

The following information is displayed: PO number, release number, document type, revision number, revised date, order date, printed date, status, closure status, supplier, supplier contact, supplier site, ship-to, ship via, freight terms, FOB, buyer, bill-to, payment terms, currency, amount, item number, item description, and end item model/unit number.

Manufacturing Plans

▶▶ To view manufacturing plans for your project

1. Select the manufacturing plans button in the Project/Task/Seiban kiosk.

The following information is displayed: plan name, plan description, plan type code, organization name, start date, completion date, and plan horizon.

2. Select a plan name to view additional details for each plan.

Note: Manufacturing plans are supported for only Oracle Manufacturing Planning users with this release.

WIP Jobs

▶▶ To view WIP jobs for your project

1. Select the WIP jobs button in the Project/Task/Seiban kiosk.

The following information is displayed: job name, Job description, job class, job status, assembly, assembly description, end item model/unit number, start date, completion date, start quantity, primary UOM, quantity completed, quantity remaining, quantity scrapped, and bom revision.

2. Choose the desired details for operations and components for each WIP job by selecting the appropriate buttons in this window.

▶▶ To view components for a project WIP job

- Select the Components button in the project WIP jobs window for a job.

The following information is displayed: item, description, primary UOM, inventory asset flag, location control code, restrict subinventories, restrict locators, operation sequence number, department, WIP supply type, date required, required quantity, quantity issued, quantity open, quantity per assembly, comments, supply subinventory, locator, MRP net flag, MPS required quantity, MPS date required, routing exists flag, first unit start date, first unit completion date, and last unit completion date.

▶▶ To view operations for a project WIP job

1. Select the operations button in the project WIP jobs window for a job.

The following information is displayed: operation sequence number, operation code, department code, description, scheduled quantity, quantity in queue, quantity running, quantity waiting to move, quantity rejected, quantity scrapped, quantity completed, first unit start date, first unit completion date, last unit start date, last unit completion date, previous operation sequence

number, next operation sequence number, count point, autocharge, backflush, minimum transfer quantity, date last moved.

2. Select the components button to view the list of components at the selected operation.

The information displayed includes item, description, primary UOM, inventory asset flag, location control code, restrict subinventories, restrict locators, operation sequence number, department, WIP supply type, date required, required quantity, quantity issued, quantity open, quantity per assembly, comments, supply subinventory, locator, MRP net flag, MPS required quantity, MPS date required, routing exists flag, first unit start date, first unit completion date, and last unit completion date.

Onhand Balances

▶▶ To view onhand balances for your project

- Select the onhand balances button for your project in the Project/Task/Seiban kiosk.

Onhand balances are displayed by organization, by item, by subinventory and by locator for each project. The following information is displayed: organization name, item, item description, subinventory, locator, primary UOM, and total onhand quantity.

Sales Orders

▶▶ To view project sales orders

- Select the Sales Orders button in the Project/Task/Seiban kiosk.

The following information is displayed: order number, PO number, order category, order type, freight terms, payment terms, customer number, customer name, order date, request date, cancelled flag, ship to location, ship method, ship priority, allow partial ship, bill to location, order amount, order currency, tax exempt, item number, item description, and end item model/unit number.

You can drill down to the line and shipment details for each sales order.

Onhand Values

▶▶ To view onhand values for your project

- Select the onhand values button in the Project/Task/Seiban kiosk.

Onhand values are displayed based on item, organization and cost group. The following information is displayed: item number, organization name, cost group, cost group description, quantity onhand, unit cost, extended inventory value, extended material value, extended material overhead value, extended resource value, extended outside processing value, and extended overhead value.

Extended value is calculated as follows:

extended inventory value = quantity onhand * unit cost

You can see the extended value of each of the cost elements as extended material value, extended material overhead value, extended resource value, extended outside processing value, and extended overhead value.

You can drill down to the cost history details by selecting the item in the onhand balances window. In the cost history window, you can view the following details: transaction costed date, transaction date, prior costed quantity, primary quantity, new quantity, transaction type, actual cost, actual material, actual material overhead, actual resource, actual overhead, prior cost, prior material, prior material overhead, prior resource, prior overhead, new cost, new material, new material overhead, new resource, new overhead, change.

Line Schedules

▶▶ To view line schedules for your project

1. Select the line schedules button in the Project/Task/Seiban kiosk.

The following information is displayed: line, planned quantity, quantity completed, variance quantity.

2. Select the line to view the item information which includes line, item number, planned quantity, quantity completed, variance quantity.
3. You can drill down to the schedule details, daily and weekly line schedules for each line in the schedule items window.

▶▶ To view details on the line schedul:

- Select the detail button for the selected line schedule.

The following information is displayed: line, project number, task number, source, schedule number, item number, start date, completion date, planned quantity, quantity completed, and variance quantity.

▶▶ To view daily schedule

- Select the daily button for the selected line schedule.

The following information is displayed: line, item number, scheduled date, planned quantity, quantity completed, and variance quantity.

▶▶ To view weekly schedule

- Select the weekly button for the selected line schedule.

The following information is displayed: line, item number, scheduled date, planned quantity, quantity completed, and variance quantity.

Attention:

- **Users can use AK Developer forms to customize the columns displayed on PJM Web Workbench. You can change/customize column prompts and display sequences also.**
 - **The Web Inquiry utilizes the views which were designed for Oracle Projects Discoverer Workbooks. All amount columns are from the PA_RPT_PRJ_SUMMARY view. Project attributes are from the PA_PROJECTS_ALL table.**
 - **All amounts are based on the current Projects reporting period. Although this period is not shown on the Web Inquiry, the amounts are based on the most recent summarization of the current reporting period.**
 - **Note that the Expenditure Drill may not match the project summary amounts due to the fact that the Expenditure Drill contains all expenditure items, including those that may not be summarized.**
 - **Manufacturing plans are supported for only Oracle Manufacturing Planning users with this release.**
-
-

Period Close in Project Manufacturing

This chapter outlines the steps required to close accounting periods in a project manufacturing environment.

The following topics are included:

- Overview
- Closing Order for Period Close
- Preliminary Checklist for Period Close
- Implementation Notes

Overview

Closing an Accounting Period can be a very time consuming task. This section provides the steps necessary to perform a period close in a Project Manufacturing environment. It is a high level overview and will reference numerous other documents. The referenced documents contain necessary and more detailed information on the steps required to close each Oracle Application. By referencing these documents you can be assured that you are getting the most detailed information possible.

Closing Order for Period Close

Close Order	Application	Oracle Document Reference/Note
1	Oracle Payables (AP)	See: Closing an Accounting Period, <i>Oracle Payables User's Guide</i> .
2	Oracle Internet Procurement	See: Controlling Purchasing Periods, <i>Oracle Internet Procurement User's Guide</i> .
3	Oracle Order Management (OM)*	See: <i>Oracle Order Management User's Guide</i> .
4	Oracle Work in Process (WIP)*	See: <i>Oracle Work in Process User's Guide</i> .
5	Oracle Inventory (INV)	See: Cost Control and Accounting, <i>Oracle Inventory User's Guide</i> .
6	Oracle Projects (PA)	See: <i>Oracle Projects User's Guide</i> and <i>Oracle Projects Student Guide</i> .
7	Oracle Accounts Receivable (AR)	See: Opening and Closing Accounting Periods, <i>Oracle Receivable User's Guide</i> .
8	Other Non-Oracle Data feeds	(If applicable - payroll, fixed assets, and so forth.)
9	Oracle General Ledger (GL)	See: Setting up Periods and Calendars, Opening and Closing Periods, <i>Oracle General Ledger User's Guide</i> .

* Oracle Order Management and Oracle Work in Process do not have periods to close, but certain actions should be performed within these applications to foster a smoother period close.

Preliminary Checklist for Period Close

Oracle Applications should be closed in the order indicated above. Keep in mind that multiple steps are required to perform period close on each application. The following table lists some of the important steps but it is not meant to be exhaustive. Do not follow only these steps or you may encounter problems. Remember to open

the next period after closing the current period unless otherwise indicated. See the Oracle Documents referenced above for further information.

Close Order	Application	Activity
1	Oracle Payables (AP)	<p>Interface supplier invoice adjustments and expense reports from Project Accounting.</p> <p>Approve all invoices (run AutoApproval).</p> <p>Print, review and resolve posting holds report.</p> <p>Confirm payment batches.</p> <p>Run unposted invoice sweep and correct entries - (DON'T Sweep).</p> <p>Review amounts to transfer to GL.</p> <p>Transfer invoices and payments.</p> <p>Run Sweep and do Sweep.</p> <p>Run and reconcile AP Trial Balance.</p> <p>Move unresolved postings.</p> <p>Close AP period.</p>
2	Oracle Internet Procurement	<p>Ensure all receiving transactions have been entered.</p> <p>Run uninvoiced receipts report and review (after AP transactions have successfully posted to GL).</p> <p>Run PPV and IPV reports and review.</p> <p>Run receipt accruals - period end process.</p> <p>Import Accrual Batches from Purchasing into GL.</p> <p>Run accrual rebuild reconciliation report and review.</p> <p>Correct all errors.</p> <p>Close PO period.</p>
3	Order Management (ONT) * Not an actual close	<p>Ensure all sales order transactions have been entered and interfaced to Oracle Inventory.</p> <p>Ensure all sales order transactions have been entered and interface to AR for sales account reporting. (Sales order transactions include ship confirm and drop shipments.)</p>
4	Oracle Work in Process (WIP) * Not an actual close	<p>Ensure WIP/Move, Pending Move, WIP/Resource, Pending Resource, and other transactions have all been processed successfully.</p> <p>Ensure all WIP Jobs have been closed that should be closed.</p> <p>Ensure all appropriate material has been issued, received, adjusted, and so forth.</p>

5	<p>Oracle Inventory (INV) *Closing INV closes WIP</p>	<p>Ensure all appropriate material has been issued, received, adjusted, and so forth. Execute Cost Collector (Project Cost Transfer). Execute PA Transaction Import (resolve errors). Update PA Project Summary amounts. Ensure Open Interface Table is empty (resolve errors). Ensure Cost Management interfaces do not have pending transactions (Material and Resource). Transfer all Inventory transactions to the GL by organization. Ensure all Inventory and WIP accounts have been reconciled on the GL. Open next Inventory Period. Close the Inventory Period (this will automatically submit a transfer to GL process). Reconcile Inventory and WIP accounts to ledger. Note/Hint: The GL transfer can be run before period close as many times as desired.</p>
6	<p>Oracle Projects (PA)</p>	<p>Transfer vendor invoices from Oracle Payables (after AP transactions have successfully posted to GL). Transfer invoices to Oracle Receivables. Generate Draft Revenue for all projects. Run journal import and ensure all costs & revenue are properly accounted for between PA and GL. Correct all errors (rerun import if necessary). Change PA period statuses. Note: Do not post adjustments to the GL for cost and revenue distribution lines. Post them in PA and transfer them to the GL.</p>
7	<p>Oracle Accounts Receivable (AR)</p>	<p>Verify final transfer from PA was successful. Correct any errors on invoices, journals, and so forth. Run GL interface. Post in GL. Close AR period. Run aging report and reconcile.</p>
8	<p>Other Non-Oracle Data feeds</p>	<p>(If applicable - payroll, fixed assets, and so forth.)</p>

9 (last)	Oracle General Ledger (GL)	This is closed last. Verify all journals have been imported. Verify all journals have been posted. Run Trial Balance Summary report. Run Posted Journals report. Close GL period.
----------	----------------------------	--

Oracle Project Manufacturing Without Oracle Projects

This chapter describes the use of Project Manufacturing without installing Oracle Projects.

The following topics are included:

- Overview
- Seiban Manufacturing
- Flow in a Project Environment

Overview

Oracle Project Manufacturing supports seiban manufacturing. *Sei ban* means production number and is widely used by manufacturers in Asian countries. However, also manufacturers in non-Asian use the various modes of the seiban manufacturing solution for their implementation, since seiban manufacturing is implemented using projects and (optionally) tasks.

Oracle Project Manufacturing can run in several modes:

1. You can use the Seiban Number Wizard to define project numbers in Oracle Project Manufacturing if you do not work with Oracle Projects. Task-level control is then not supported and neither is cost collection to Oracle Projects. You can run either standard or weighted average costing. If you use the last costing method we keep track of cost by item by cost group for all manufacturing cost associated with a project (= seiban) number.
2. You can use project management systems or direct entry in Oracle Projects to define project and task numbers. Oracle Project Manufacturing uses these projects and tasks to drive supply chain management. The end result is that cost are collected into Oracle Projects using the cost collection process. The cost method supported is weighted average costing by item by project. This mode is generally used to support ETO Seiban for Asian manufacturers.
3. You can use the Seiban Number Wizard to generate a project with top-level task structure in Oracle Projects. This wizard also allows you to add one or more top level tasks to a project after you initially generated the project. This always you to collect cost for multiple lots that are manufactured in Work In Process into Oracle Projects using the cost collection process. A manufactured lot typically is represented by one WIP Job that is associated with one project-task combination. In this case the project-task combination represents the seiban number, and this technique is commonly referred to as lot-type seiban by Asian manufacturers. The cost method supported for this mode is weighted average costing by item by project.

Note: The difference between using the reference number and project number is that you can not collect cost by reference number as you can by project.

Setup

The Oracle Project Manufacturing setup process includes various steps within Oracle Applications. However, in a Project environment, the user will not execute the set up steps related to transferring of costs to Oracle Projects. Instead the following steps will be implemented to set up Project Manufacturing.

Application	Step	Form Name
Human Resources	Set up Organization	Organization
Human Resources	Set up Organization Hierarchy	Organization Hierarchy
Inventory	Set up Inventory Organization Parameters	Organization Parameters
Bill of Materials	Set up Department in Manufacturing	Departments
Project Manufacturing	Set up Project Parameters	Project Parameters

Refer to each product's User's Guide for additional information.

Additionally, the user needs to verify that

- The Project Control level in Organization Parameters is set to Project. In a Project environment, the user will track material and resource, and hence cost, at the project level
- Project Cost Collection in Organization Parameters is disabled, since Oracle Projects is not being used in a Project environment
- Project Numbers are defined in the Define Seiban Number form in Oracle Project Manufacturing

Since Oracle Projects is not being used in a Project environment, Project Cost Collection is not enabled. The user can select either Standard Costing or Weighted Average Costing as the costing method.

Flow in the Project environment

The Project Number is defined in Oracle Project Manufacturing. The user references this number on all demand and supply entities to track material and resource activities and cost by Project Number.

Figure 17-1 outlines the flow in a Project environment. The following sections describes the various supported features in a Project environment.

Project Definition

Project Numbers are defined in Oracle Project Manufacturing, not in Oracle Projects. Tasks cannot be associated with the Project Numbers since there is no WBS. The Project Number and Name are unique within an Operating Unit. The Project Number needs to be associated with a Cost Group (if costing method = Weighted Average Costing) and WIP Accounting Class in the Project Parameters form.

Project Demand

Oracle Project Manufacturing enables the demand (sales order, forecast or Master Demand/Master Production Schedule entry) to be entered with a Project Number to drive manufacturing planning, execution and costing. For example, the user can create a Project sales order by linking a sales order line to a Project Number. Similarly, the user can create a Project Forecast by linking a forecast entry to a Project Number. The user can also perform other Project Sales Management activities such as Project Quotations, Project ATO/PTO, Project Fulfillment, and Project Drop shipments with Project references.

Project Planning

In Oracle Project Manufacturing, the planning cycle can be executed for one organization or across an entire supply chain while planning project items in combination with common items. Oracle Project Manufacturing Planning features include:

- Graphical hard and soft pegging
- Group netting

- On-line simulation of project supply and demand changes
- Project exception message

Item	Type	29-JUN-1998	27-JUL-1998	24-AUG-1998	28-SEP-1998	26-OCT-1998	23-NOV-1998
AS40804	Sales orders	0	0	0	0	0	0
AS40804	Forecast	0	0	0	0	0	35
AS40804	Dependent demand	0	0	0	0	0	0
AS40804	Gross requirements	0	0	0	0	0	35
AS40804	WIP	0	0	0	0	0	0
AS40804	Purchase orders	0	15	0	0	0	0
AS40804	Requisitions	0	0	0	0	0	0
AS40804	Planned orders	0	0	0	0	0	28
AS40804	Total supply	0	15	0	0	0	28
AS40804	Beginning on hand	7	0	0	0	0	0

In the Planner Workbench, the user can view project exceptions, the project horizontal plan, supply and demand per Project, simulate new or existing project demand, and release planned orders by Project. Planning Group and/or Project can be used as MRP planning criteria and as search criteria in the Planner Workbench. The user can plan material requirements while respecting hard pegs on all supply orders and generate planned orders with Project references appropriately. Items can be soft or hard pegged, allowing for various pegging methods within a bill of material.

Project Supply/Execution

Project Planned Orders resulting from the planning cycle can include Purchase Requisitions/Blanket Releases for Buy Items (Project Procurement), WIP jobs/flow schedules for make items (Project Work in Process/Flow Manufacturing), and internal orders driven by inter-company supply.

Project Procurement

Project references are supported through all procurement entities such as RFQ, Quotations, Requisitions, Purchase Order, and Blanket Release for Inventory destinations. Expense destinations for Project Procurement are not currently

supported. The user cannot view commitments for a given Project since this functionality comes with Oracle Projects.

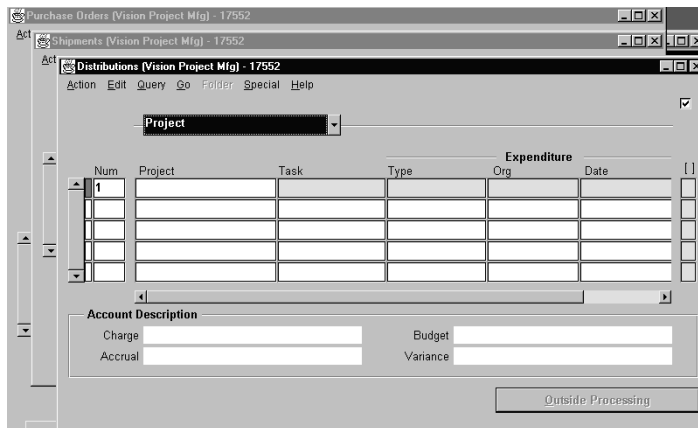

Project Work in Process

WIP jobs/work orders, both standard and non-standard are supported in a Project environment. Outside Processing functionality can be used with the Project reference on the Work order, which is then transferred to the generated outside processed purchase requisition. The user can link Project Number to a flow schedule in a workorder-less production environment. Material issue, back-flush

and completions can be executed for a Project with appropriate automatic defaults and validations for Project WIP jobs.

The screenshot shows the 'View Discrete Jobs (P1)' window with the following data:

Field	Value
Job	PGTest
Assembly	AS40804
Industrial Pump	Industrial Pump
Type	Standard
Class	Discrete
UOM	Ea
Status	Released
Firm	<input type="checkbox"/>
Quantities - Start	7
MRP Net	0
Dates - Start	20-OCT-1998 00:00:00
Completion	26-OCT-1998 12:12:00
Schedule Group, Project	Asean Pumps
Schedule Group	
Build Seq	
Line	
Project	Asean Pumps
Task	

Project Inventory

In a Project environment, the user can track inventory by Project, while dealing with transfers from one Project to another, or from common inventory to project inventory or vice-versa. Existing material transactions such as Miscellaneous Issue or Receipt, Subinventory Transfers, PO Receipt, WIP Issue, WIP Returns, or WIP Completions can be used to handle Project material transaction needs.

Project Quality

Using Oracle Quality, the user can track Project related quality data. The user can collect Project Number as a part of the quality data collection in a Project environment. Using the collected data, the user can analyze the Quality information

by Project. Project specific quality specifications can be set up and then referenced during quality data collection.

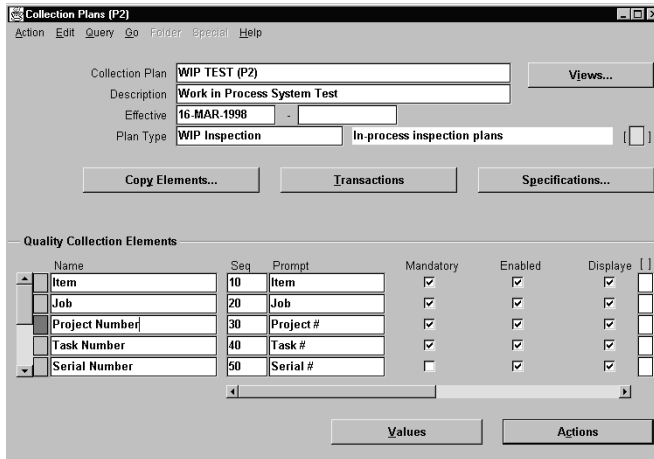

Project Costing Methods

Manufacturing labor, material, and overhead distributions are created in Oracle Cost Management as a result of WIP or Inventory transactions. If Oracle Project Manufacturing has been set up to use Weighted Average Costing, then Cost Groups will be associated with each Project. Costs will be tracked by Cost Group by item in each Project Organization. If Oracle Project Manufacturing is set up to use Standard Costing, then costs are tracked at the item level in each organization.

Project Analysis and Control

In a Project environment, the PJM Web Workbench can be used to analyze manufacturing information. This workbench would provide the drilldowns from a Project to the Purchasing, WIP, Cost, Planning, and Inventory details. Other existing reports (concurrent requests) which can be used to analyze seiban activity, include Inventory Valuation and WIP Valuation. Project Expenditure Inquiry or Project

Status Inquiry (features of Oracle Projects) are not available to view cost details or summarization by Project since Oracle Projects is not installed in this environment.

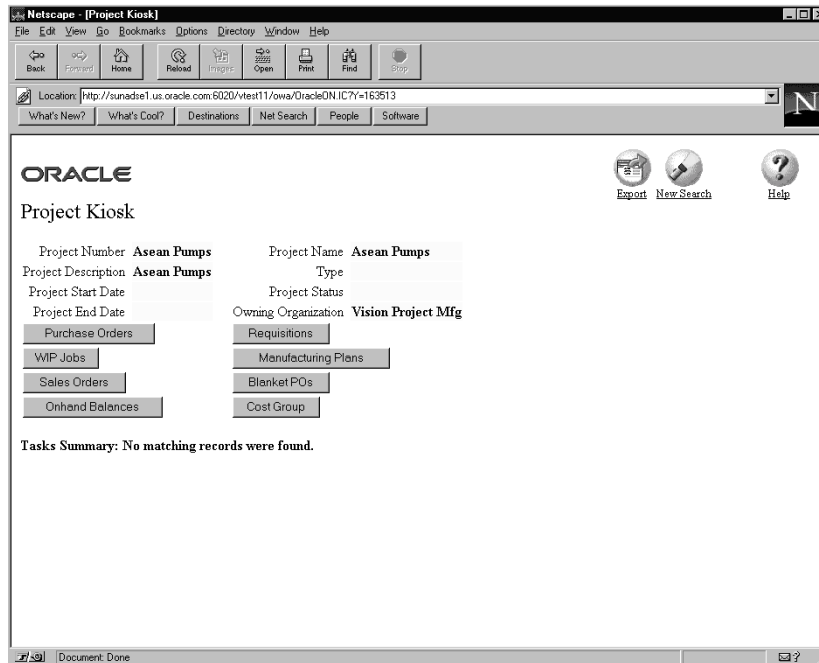

Project Billing

In Release 11 Project Manufacturing, the user has the option of driving billing activity into Oracle Receivables through Oracle Order Management or Oracle Projects. In a Project environment, the user will driving the billing activity through Oracle Order Management into Oracle Receivables, since Oracle Projects is not installed.

On completion of the shipment activity, the user will execute the Oracle Order Management cycle step Receivables Interface to pass the sales order line information into Oracle Receivables. In Oracle Order Management, order cycles are composed of distinct cycle actions. A cycle action indicates a processing step such as entering the order, reviewing the order for legal approval, or pick releasing the order. Cycle actions produce specific results for example, the action of entering the order can result in the order being partially entered or being booked.

The user will then follow the standard procedure in Oracle Receivables to complete the billing process.

Project Revenue Recognition

In a Project environment, the user will recognize revenue using Oracle Receivables. The AutoInvoice Import or Master program will be used to transfer transactions from Oracle Order Management into Oracle Receivables. The user can also pass invoices, credit memos, on-account credits, and debit memos using AutoInvoice. The user will run the Revenue Recognition program in Oracle Receivables to generate the revenue distribution records for invoices and credit memos that are created in Receivables and imported using AutoInvoice. The user will assign invoicing and accounting rules to recognize revenue over several accounting periods.

Summary

Table 1 summarizes the differences in the Project Manufacturing with Oracle Projects solution and Project solution (Project Manufacturing without Projects).

Table 7: Comparison of Oracle Project Manufacturing with and without Oracle Projects

Business Function	Step Description	Result	
		Project Manufacturing with Oracle Projects	Project Manufacturing
Setup (Organization Parameters)	Project Reference	Enabled	Enabled
	Project Cost Collection	Enabled	Not Enabled
	Control Level	Project and Task	Project
	Costing Method	Weighted Average Cost	Weighted Average Cost or Standard Cost
Project Definition	Work Breakdown Structure	The project with its WBS, can be defined in Oracle Projects or Project Management System	The seiban number will be defined in the Define Seiban Number form in Oracle Project Manufacturing; a WBS will not be defined
Project Demand	Project Demand (Order Management / Planning)	Demand entities will include project and/or task references	Demand entities will carry Project references

Table 7: Comparison of Oracle Project Manufacturing with and without Oracle Projects

Project Supply / Execution	Project Procurement	The user can enter project and/or task references on all procurement entities for inventory and expense destinations	The user can enter Project references on procurement entities for inventory destinations only. Project procurement for expense destinations are not currently supported
	Project Commitments	The user can view commitments by project due to project related procurement in Oracle Projects	The user will not be able to view commitments by Project since Oracle Projects is not installed
	Project Work In Process	The user can enter project and/or task references on Standard, Non-Standard Jobs and Flow schedules	The user can enter Project references on Standard, Non-Standard Jobs and Flow Schedules
	Project Inventory	The user can support miscellaneous transactions and Inventory transfers with project and/or task references. Project Miscellaneous Transactions to issue/receive common inventory	The user can support miscellaneous transactions and Inventory transfers with Project references; since Oracle Projects is not installed, the user cannot perform Project Miscellaneous Transactions
	Project Quality	Project and/or task references are supported in quality data collection, analysis and reporting	Project references are supported in quality data collection, analysis and reporting
Project Control and Analysis	Project Status Inquiry (PSI), Project Expenditure Inquiry	The user can compare budget to actual at the project and task level using PSI. The user can perform analysis by project, task, expenditure type, expenditure category and so on using the Expenditure Inquiry	Since Oracle Projects is not installed in a Project environment these inquiries are not available
	Project Web Workbench (PJM workbench)	The user can view detailed or summarized manufacturing information for a given project and/or task	The PJM workbench allows the user to view summarized and detailed manufacturing and cost information for a given Project Number

Table 7: Comparison of Oracle Project Manufacturing with and without Oracle Projects

	Other Reports	The user can perform analysis at the project and/or task level using the Project Analysis Collection Pack and other Oracle Project reports	The user can run standard reports such as Inventory Valuation, or WIP Valuation to track Project cost
Project Billing	Billing driven through Order Management to Oracle Receivables or through Oracle Projects to Oracle Receivables	The user will drive billing through Oracle Projects to allow the use of the multiple billing methods available in Oracle Projects such as event driven billing, progress billing, and so on	The user will drive billing through Order Management to Oracle Receivables. On completion of customer shipment in Oracle Order Management, the user will run the Receivables Update program which passes the relevant sales order data to Oracle Receivables. The user will complete the billing activity using standard procedure in Oracle Receivables
Project Revenue Recognition	Revenue recognition in Oracle Projects or Oracle Receivables	The user will generate revenue in Oracle Projects using various methods including time and materials, percent complete, and cost plus	The user will perform revenue recognition in Oracle Receivables. By executing the Revenue Recognition program the user will generate the revenue distribution records for invoices and credit memos that are created in Receivables and imported using AutoInvoice

See Also*Oracle Project Manufacturing User's Guide*

Index

A

Actions, 12-6
ATO/PTO
 features, 11-2
 process flow, 11-3
 process steps, 11-4
 project/task defaulting logic, 11-7
ATP, 13-7
Attachments, 12-6
Auto-Create RFQ, 9-7

C

Closing Order, 16-2
Collection Elements, 12-3
Collection Plans, 12-5
Committed Costs, 9-4
Common Locator, 2-29
 comparison, 2-30
Costing Information, 2-28
Cross Project Allocation, 2-37

D

Data Collection, 12-6
Discrete Job
 completion locator, 2-33
 completion transaction, 2-34
 component issue transaction, 2-34
 component return transaction, 2-35
 material requirements, 2-34
 return assembly to WIP transaction, 2-35
Documentation Reference, 16-2

Drop Shipment
 features, 13-3
 process steps, 13-5

E

Expenditure Organizations, 2-37
Expense Purchases, 9-6

H

Hard pegging level
 project netting example, 7-6

I

Implementation Notes, 2-37, 9-5, 13-7
Inventory Purchases, 9-6

L

Locator Flexfield, 2-29

M

Manufacturing Department, 2-37
Manufacturing Transactions, 2-38
Material requirements plans
 planning logic
 project MRP, 7-4
 project MRP netting behavior, 7-5

N

- Netting supply and demand
 - project MRP netting behavior, 7-5
 - project MRP planning logic, 7-4

O

- Organization Classification, 2-22
- Organization Hierarchy, 2-24
 - concepts, 2-24
 - in Oracle Projects, 2-24

P

- Period Close, 16-2
- Pick Release, 2-36
- Planning
 - logic
 - project MRP, 7-4
 - project MRP netting behavior, 7-5
- Planning Group Quick Codes
 - defining, 4-3
- Planning Groups, 2-46
- PO Adjustment Transaction, 2-33
- PO Delivery Transaction, 2-32
- PO Return Transaction, 2-32
- preface
 - PT PrefaceTitle, xi
- Process Flow, 8-3, 11-3, 13-4
- Procurement Flow, 9-2
- Profile
 - PJM
 - Allow Cross Project Issues, 2-35
- Project Information Region, 2-26
- Project Locator, 2-29
 - comparison, 2-30
 - definition, 2-30
- Project MRP
 - common supply, 7-4
 - main features of, 7-1
 - netting behavior, 7-5
 - planning logic, 7-4
 - pre-allocation phase, 7-4
 - project netting
 - hard pegged item, 7-6
 - soft pegged item, 7-6

- soft pegged item, 7-6
- setting up
 - assigning projects to planning groups, 4-1
 - defining Seiban numbers, 4-6
- Project Parameters window
 - assigning projects to planning groups, 4-2
- Project/Task Defaulting Logic, 11-7
- PT PrefaceTitle, xi

Q

- Quality Process Flow, 12-3
- Quality results, 12-7
- QuickCodes
 - planning group
 - assigning projects to planning groups, 4-1
 - Seiban number, 4-6

R

- Receiving, 9-7
- Request For Quotation, 9-4
- Requisitions, 9-5

S

- Seiban Numbers window
 - defining Seiban numbers, 4-6
- Setting up
 - Project MRP
 - assigning projects to planning groups, 4-1
 - defining Seiban numbers, 4-6
- Soft Pegging, 2-34
- Soft pegging level
 - project netting example, 7-6
- Specifications, 12-4
 - elements, 12-5
 - subtypes, 12-4
- Stock Locators, 2-29, 2-30
 - locator flexfield, 2-29
 - setting up, 2-29
- Supply Chain Projects
 - features, 8-2
 - process flow, 8-3
 - process steps, 8-3

W

Windows

Project Parameters window

assigning projects to planning groups, 4-2

Seiban Numbers

defining Seiban numbers, 4-6

Work Order-less Completions, 2-35

