

Chem 4571

Organometallic Chemistry

Lecture Notes

**Prof. George G. Stanley
Department of Chemistry
Louisiana State University
614 Choppin Hall
578-3471
E-Mail: gstanley@lsu.edu**

Spring, 2006

(updated 1/15/2006)

Class A, B, & C oxidative addition substrate labels dropped. Some new, clearer mechanisms in hydrogenation and hydroformylation chapters. New material added to polymerization chapter (metathesis polymerization, late TM polymerization). New chapter on Pd-catalyzed coupling rxns (by Prof. Lionel Delaude, University of Liege in Belgium).

Chemistry 4571 - Organometallic Chemistry (Sp 2006)

Prof. George G. Stanley (office: Choppin 614, phone: 578-3471)

E-Mail: gstanley@lsu.edu

Tuesday - Thursday Lecture 9:10 AM - 10:30 AM Williams 103

This is an advanced undergraduate, introductory graduate level course that covers the organometallic chemistry of the transition metals with emphasis on basic reaction types and the natural extensions to the very relevant area of homogeneous (and heterogeneous) catalysis. An outline of the course contents is shown below:

A. Ligand Systems and Electron Counting

1. Oxidation States, *d* electron configurations, 18-electron "rule"
2. Carbonyls, Phosphines & Hydrides
3. σ bound carbon ligands: alkyls, aryls
4. σ/π -bonded carbon ligands: carbenes, carbynes
5. π -bonded carbon ligands: allyl, cyclobutadiene, cyclopentadienyl, arenes.

B. Fundamental Reactions

1. Ligand substitutions
2. Oxidative addition/Reductive elimination
3. Intramolecular insertions/eliminations
- [4. Nucleophilic/Electrophilic attacks on coordinated ligands (brief coverage, if any)]

C. Catalytic Processes

1. Hydrogenation: symmetric and asymmetric
2. Carbonylations: hydroformylation and the Monsanto Acetic Acid Process
3. Polymerization/oligomerization/cyclizations

Web Site: chemistry.lsu.edu/stanley/teaching-stanley.htm. Class materials will be posted on the web.

Recommended Text: *"The Organometallic Chemistry of the Transition Metals"* by Robert Crabtree (4th Edition, Wiley). **Reference Text:** *"The Principles and Applications of Transition Metal Chemistry"*, by Collman, Hegedus, Norton and Finke (1st or 2nd eds, University Science Books).

Class Lecture Notes (Required): Copies of the lecture overheads used (and previous homeworks and exams along with answer keys) can be downloaded from the web site above or purchased from Prof. Stanley (any profit will be used for Chemistry Graduate Student Recruiting).

Study Groups: The class will form study groups of 1-4 students to work together on the homework and to answer questions in class (work alone on quizzes).

Grading:	Two 80 min Exams:	300 pts	30%	(Feb 23 & April 6, <i>could change</i>)
	Final Exam (2 hrs):	250 pts	25%	(Weds, May 10 – 10:00 AM - Noon)
	4 Homeworks:	300 pts	30%	
	25 in-class Quizzes	150 pts	15%	
	Bonus Homework	50 pts	bonus	Visit a High School Chem Class to perform catalysis demos

Grading Scale (no curve): A (100-90%), B (89-80%), C (79-70%), D (69-60%), F (below 60%)

If I give a test that is too hard (i.e., the class does poorer than I expect) I may curve the scores up to compensate. The exact criteria for when I will do this and the amount of the curving will not be defined here. You will have to trust my judgment. **Grades will be posted on PAWS via Semester Book.**

Please note that the majority of points on the homeworks and exams come during the second half of the semester!! The first 2 homework assignments are only worth 50 points each, while the last two homeworks are worth 100 points each. **IT IS CRITICALLY IMPORTANT, HOWEVER, THAT YOU LEARN THE MATERIAL IN THE FIRST 50-66% OF THE COURSE IN ORDER TO DO WELL ON THE LAST EXAM AND FINAL EXAM.** The final exam, for example, only covers catalysis (last 20% of the course), but uses all the info learned up to that point.

Bonus Homework: The bonus homework assignment involves visiting a high school chemistry class and performing a set of demonstrations that illustrate catalysis and related chemistry topics. There is a 2-4 page written (typed) report required describing your experience (maximum 20 points) and an evaluation card sent to the teacher whose class you visit (maximum 30 points). Both must be received to get credit.

Office Hours: I have open office hours.

Class Calendar:

January, 2006

Mon	Tue	Wed	Thur	Fri
	3		5	
	10		12	
	17		19	
	24		26	
	31			

February, 2006

Mon	Tue	Wed	Thur	Fri
			2	
	7		9	
	14		16	
	21		23	
	28			
	Mardis Gras Holiday			

March, 2006

Mon	Tue	Wed	Thur	Fri
			2	
	7		9	
	14		16	
	21		23	
	28		30	

April, 2006

Mon	Tue	Wed	Thur	Fri
	4		6	
			Test # 2	
	11		13	
	Spring Break			
	18		20	
	25		27	

May, 2006

Mon	Tue	Wed	Thur	Fri
	2		4	
		10		
	Final Exam 10:00 AM - Noon			

Fundamentals You Need to Know:

1. Electronegative/Electropositive concepts

Where do the positive and negative partial charges in a molecule reside? This is important for determining how much e- density will be donated from a ligand to a metal and where a nucleophile or electrophile will attack for chemical reactions.

2. Lewis dot structures and valence electron counts

Important for determining the number of electrons on a ligand and what the charge of the ligand is. We almost always deal with ligands with even # of electrons. If a ligand has an odd # of electrons we add additional electrons to get to an even # – often to form a closed shell electron configuration with a formal negative charge.

3. Organic line notation for drawing structures

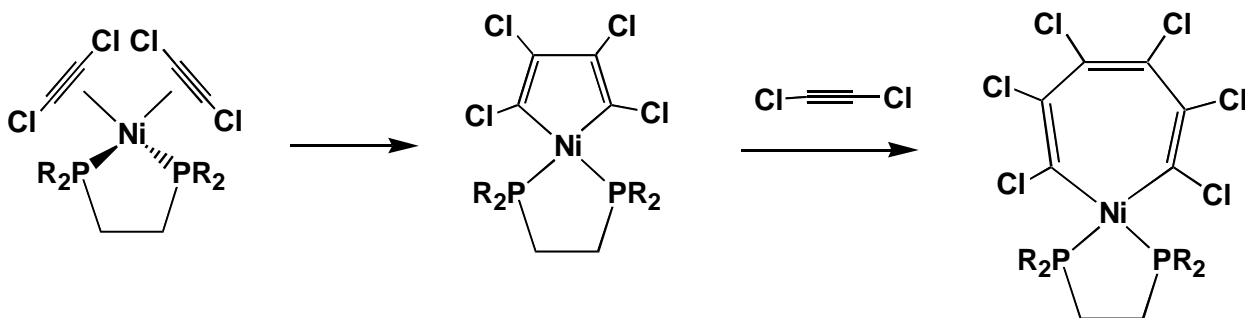

Periodic Table of the Elements

18

1	2	13	14	15	16	17	18
H Hydrogen		B Boron	C Carbon	N Nitrogen	O Oxygen	F Fluorine	He Helium
3	4	5	6	7	8	9	10
Li Lithium	Be Beryllium	B Boron	C Carbon	N Nitrogen	O Oxygen	F Fluorine	Ne Neon
11	12	13	14	15	16	17	18
Na Sodium	Mg Magnesium	Al Aluminum	Si Silicon	P Phosphorus	S Sulfur	Cl Chlorine	Ar Argon
19	20	21	22	23	24	25	26
K Potassium	Ca Calcium	Sc Scandium	Ti Titanium	V Vanadium	Cr Chromium	Mn Manganese	Fe Iron
37	38	39	40	41	42	43	44
Rb Rubidium	Sr Strontium	Y Yttrium	Zr Zirconium	Nb Niobium	Mo Molybdenum	Tc Technetium	Ru Ruthenium
55	56	57	72	73	74	75	76
Cs Cesium	Ba Barium	La Lanthanum	Hf Hafnium	Ta Tantalum	W Tungsten	Re Rhenium	Os Osmium
87	88	89	104	105			
Fr Francium	Ra Radium	Ac Actinium					
			28	27	26	25	24
			Ni Nickel	Co Cobalt	Fe Iron	Mn Manganese	Cr Chromium
			29	28	27	26	25
			Cu Copper	Ni Nickel	Co Cobalt	Fe Iron	Mn Manganese
			30	29	28	27	26
			Zn Zinc	Cu Copper	Ni Nickel	Co Cobalt	Fe Iron
			31	30	29	28	27
			Ga Gallium	Zn Zinc	Cu Copper	Ni Nickel	Co Cobalt
			32	31	30	29	28
			Ge Germanium	Ga Gallium	Zn Zinc	Cu Copper	Ni Nickel
			33	32	31	30	29
			As Arsenic	Ge Germanium	Ga Gallium	Zn Zinc	Cu Copper
			34	33	32	31	30
			Se Selenium	As Arsenic	Ge Germanium	Zn Zinc	Cu Copper
			35	34	33	32	31
			Br Bromine	Se Selenium	As Arsenic	Ge Germanium	Cu Copper
			36	35	34	33	32
			Kr Krypton	Br Bromine	Se Selenium	As Arsenic	Ge Germanium
			49	48	47	46	45
			In Indium	Cd Cadmium	Ag Silver	Pd Palladium	Rh Rhodium
			50	49	48	47	46
			Sn Tin	In Indium	Cd Cadmium	Ag Silver	Pd Palladium
			51	50	49	48	47
			Sb Antimony	Sn Tin	In Indium	Cd Cadmium	Ag Silver
			52	51	50	49	48
			Te Tellurium	Sb Antimony	Sn Tin	In Indium	Cd Cadmium
			53	52	51	50	49
			I Iodine	Te Tellurium	Sb Antimony	Sn Tin	In Indium
			54	53	52	51	50
			Xe Xenon	I Iodine	Te Tellurium	Sb Antimony	Sn Tin
			81	80	79	78	77
			Tl Thallium	Hg Mercury	Au Gold	Pt Platinum	Ir Iridium
			82	81	80	79	78
			Pb Lead	Tl Thallium	Au Gold	Pt Platinum	Ir Iridium
			83	82	81	80	79
			Bi Bismuth	Pb Lead	Au Gold	Pt Platinum	Ir Iridium
			84	83	82	81	80
			Po Polonium	Bi Bismuth	Au Gold	Pt Platinum	Ir Iridium
			85	84	83	82	81
			At Astatine	Po Polonium	Au Gold	Pt Platinum	Ir Iridium
			69	68	67	66	65
			Tm Thulium	Po Polonium	Au Gold	Pt Platinum	Ir Iridium
			70	69	68	67	66
			Yb Ytterbium	Po Polonium	Au Gold	Pt Platinum	Ir Iridium
			71	70	69	68	67
			Lu Lutetium	Po Polonium	Au Gold	Pt Platinum	Ir Iridium
			101	100	99	98	97
			Md Mendelevium	Po Polonium	Au Gold	Pt Platinum	Ir Iridium
			102	101	100	99	98
			No Nobelium	Po Polonium	Au Gold	Pt Platinum	Ir Iridium
			103	102	101	100	99
			Lr Lawrencium	Po Polonium	Au Gold	Pt Platinum	Ir Iridium

Group 8

Lanthanides

Actinides

General Trends for the Transition Metals

Group 8 Metals

d^3	d^4	d^5	d^6	d^7	d^8	d^9	d^{10}	$d^{10}s^1$
21 Sc Scandium	22 Ti Titanium	23 V Vanadium	24 Cr Chromium	25 Mn Manganese	26 Fe Iron	27 Co Cobalt	28 Ni Nickel	29 Cu Copper
39 Y Yttrium	40 Zr Zirconium	41 Nb Niobium	42 Mo Molybdenum	43 Tc Technetium	44 Ru Ruthenium	45 Rh Rhodium	46 Pd Palladium	47 Ag Silver
57 La Lanthanum	72 Hf Hafnium	73 Ta Tantalum	74 W Tungsten	75 Re Rhenium	76 Os Osmium	77 Ir Iridium	78 Pt Platinum	79 Au Gold

Early Transition Metals

low electronegativities

higher oxidation states

“harder” metal centers

OXOPHILIC!!

Late Transition Metals

higher electronegativities

lower oxidation states

“softer” metal centers

Transition Metal Catalysis



A catalyst is a substance that increases the rate of rxn without itself being consumed (but it is involved!) in the reaction. After the rxn is finished you should be able to recover the catalyst from the rxn mixture unchanged. A catalyst speeds up the rate at which a chemical reaction reaches equilibrium. The overall thermodynamics of the rxn is **NOT** changed by the catalyst. Therefore, very **endothermic** (*non-spontaneous*) reactions are usually NOT suitable for catalytic applications.

A catalyst provides a **lower energy pathway** for the production of **products** from **reactants**, thus allowing the rxn to proceed **faster**. It lowers the **activation energy** for a rxn (**kinetics**) – it does NOT change the **thermodynamics** of a rxn.

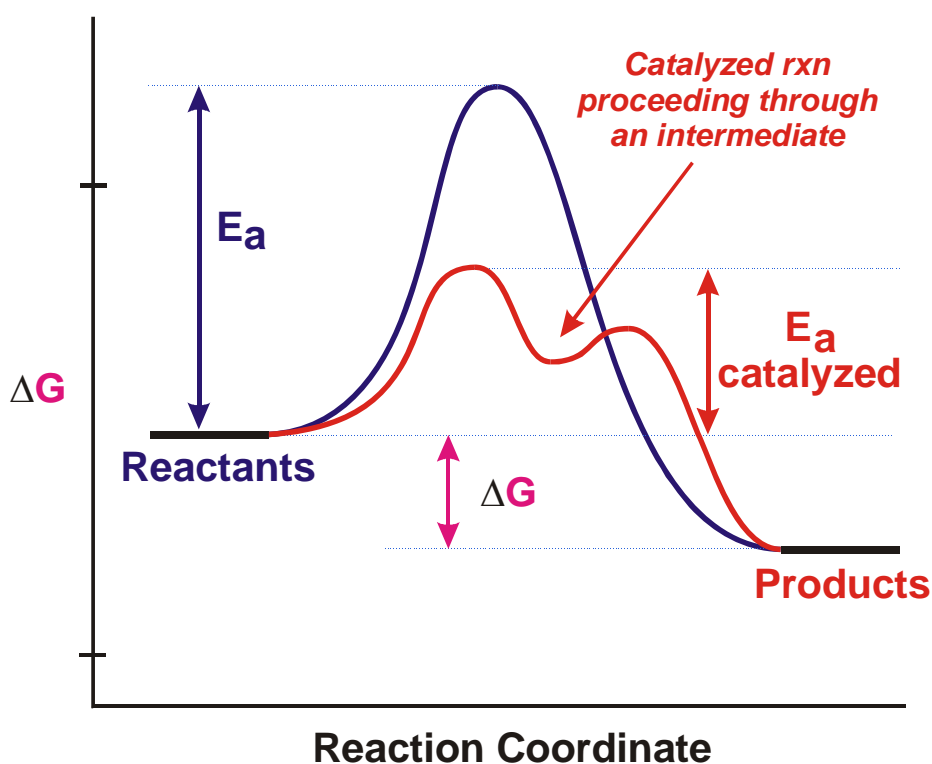

A catalyst provides an **alternate mechanism** (or pathway) for the **reactants** to be transformed into **products**. The catalyzed mechanism has an **activation energy** that is lower than the original uncatalyzed rxn. An excellent catalyst will lower the activation energy the most.

An example of a Pt-catalyzed reaction is shown below:

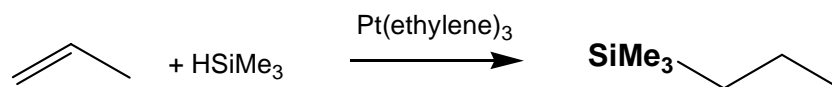

Hydrosilylation

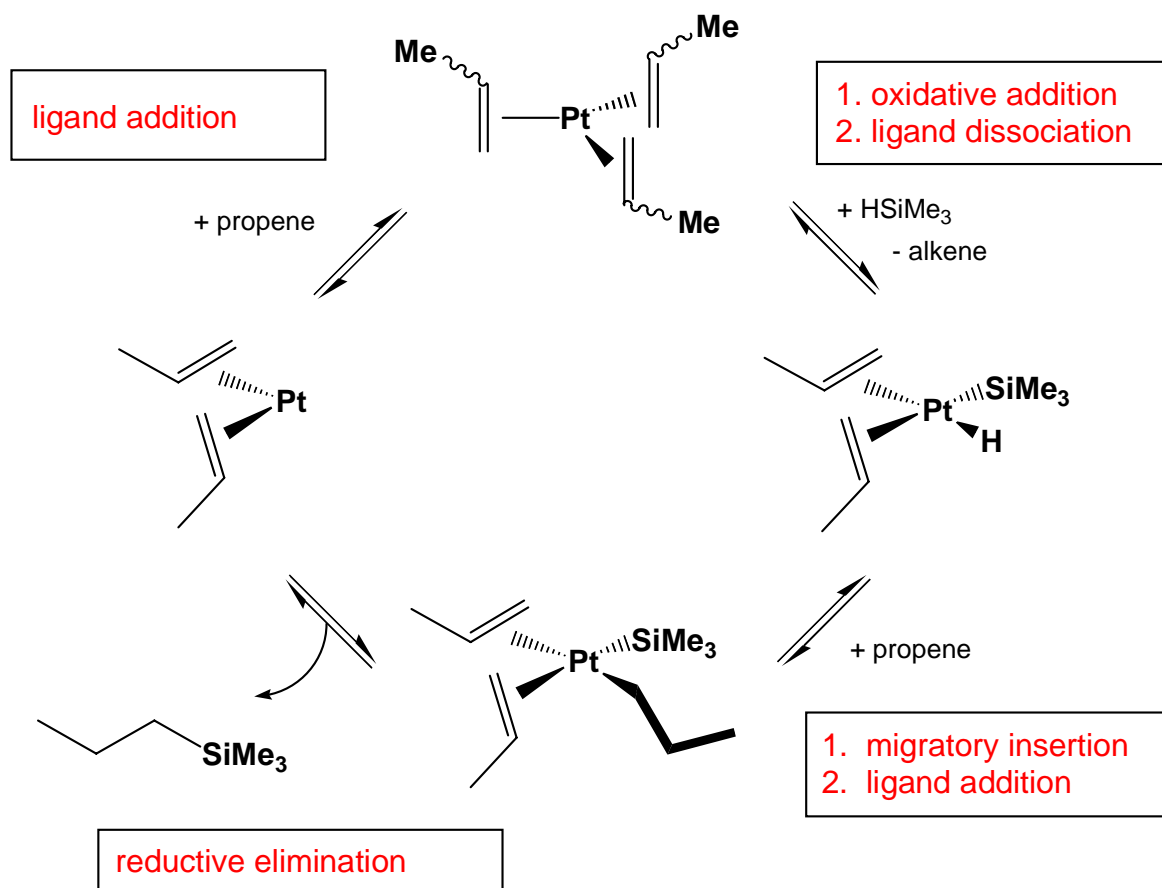

Note that there are different numbers of **ligands** (a generic name for anything that bonds to a metal center) on the metal. Too many is bad, too few is bad. How can you tell how many to use?? **Electron counting** is the key, which will be presented later in this chapter.

There are two broad classes of catalysts:

Heterogeneous Catalysis: Technically speaking this is when the catalyst is in a different phase than the reactants and products. Practically, it is usually when the catalyst is a solid and the reactants and products are liquids or gases. On a solid catalyst, only the surface of the catalyst is where the reaction will occur – so the more surface area available the more catalysis can occur. Industry makes extensive use of heterogeneous catalysts due to the ease of separating products from the catalyst.

Homogeneous Catalysis: This is when the catalyst is in the same phase as the reactants & products. Practically, this is usually in the liquid or solution phase. Homogeneous catalysts are usually molecules dissolved in solution. Industry only uses homogeneous catalysts when selectivity is important due to problems associated with separating liquid products from the catalysts solution.

Some Important Ligand Nomenclature

Chelate Effect “chelate” is from the Greek meaning “claw” or to grab on to. The chelate effect or chelation is one of the most important ligand effects in transition metal coordination chemistry. Since most metal-ligand bonds are relatively weak compared to C-C bonds, M-L bonds can often be broken rather easily, leading to dissociation of the ligand from the metal. Consider the two metal ligand complexes shown below:

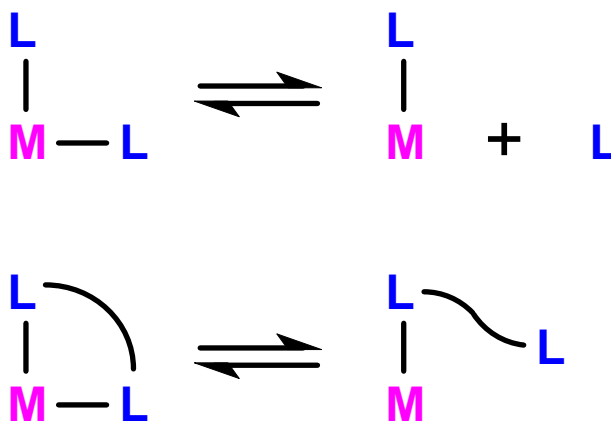

The second metal complex is much less likely to lose one of the ligands due to the bridging group that holds the ligands in proximity to the metal center. From a kinetic viewpoint, if one of the ligands dissociates, it will remain close enough to the metal center to have a high probability of re-coordinating before another ligand can get in and bind. From a thermodynamic viewpoint, by tethering two donor ligands together, one removes the entropic driving force for dissociating a ligand and thus making more particles in solution (more disorder).

The chelate effect can be extremely dramatic. There are cases known where the presence of a chelate will change the equilibrium constant by a factor of 10^{10} favoring the coordinated form of the ligand to the metal over the dissociated form. Naturally, the longer and more flexible the bridging group in a chelating ligand, the less dramatic the chelating effect. It is possible to design ligands with sterically enforced chelates.

η^x “eta- x ” was originally developed to indicate how many carbons of a π -system were coordinated to a metal center. **Hapticity** is another word used to describe the bonding mode of a ligand to a metal center. You will occasionally see h^x used instead of η^x , although this usually an error caused by forgetting to turn a regular font **h** into the *symbol* font on most word processors in order to get a Greek η . An η^5 -cyclopentadienyl ligand, for example, has all five carbons of the ring bonding to the transition metal center.

η^x values for carbon ligands where the x value is **odd** usually indicate **anionic** carbon ligands (e.g., η^5 -Cp, η^1 -CH₃, η^1 -allyl or η^3 -allyl, η^1 -CH=CH₂). The # of electrons donated (ionic method of electron counting) by the ligand is usually equal to $x + 1$. **Even** η^x values usually indicate **neutral** carbon π -system ligands (e.g., η^6 -C₆H₆, η^2 -CH₂=CH₂, η^4 -butadiene, η^4 -cyclooctadiene). The # of electrons donated by the ligand in the **even (neutral)** case is usually just equal to x .

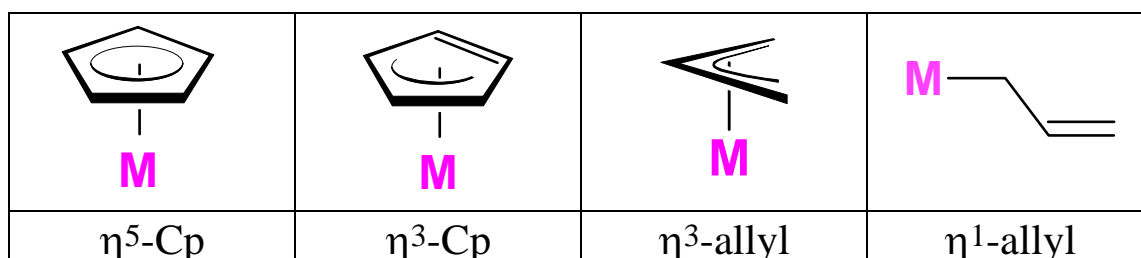

The nomenclature, however, has been generalized by most in the organometallic field to include non-carbon ligands when there is some question as to the bonding mode (or hapticity) of the ligand donor atoms to the metal. For example, the bisphosphine Ph₂PCH₂CH₂PPh₂ (dppe) is normally a chelating ligand, but there are metal complexes known where only one of the phosphine atoms is coordinated to the metal center and the other is “dangling.”

The nomenclature for such a singly coordinated bisphosphine ligand would be: $M(\eta^1\text{-dppe})$ -- meaning that only one of the two possible phosphorus atoms is bonded to the metal. Note that in cases like this, having an odd hapticity does NOT mean that the ligand is anionic (it is, however, a 2 electron donor!). When dppe is coordinated in its normal chelating mode, one usually omits the η^2 -designation, as this is considered redundant. Note that many authors use κ^x instead of η^x when referring to non-carbon ligands.

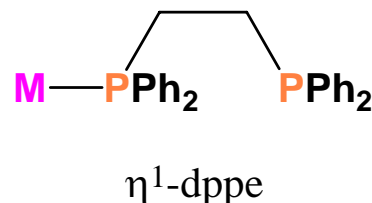

μ_x “mu-x” is the nomenclature used to indicate the presence of a **bridging ligand** between two or more metal centers. The x refers to the number of metal centers being bridged by the ligand. Usually most authors omit $x = 2$ and just use μ to indicate that the ligand is bridging the simplest case of two metals.

Ordering There is no set method of naming or ordering the listing of metal and ligands in a metal/ligand complex that most authors follow. There are IUPAC formalisms, but hardly anyone follows them. There are some qualitative rules that most authors seem to use in American Chemical Society (ACS) publications:

- 1) in formulas with Cp (cyclopentadienyl) ligands, the Cp usually comes first, followed by the metal center: Cp_2TiCl_2
- 2) other anionic multi-electron donating ligands are also often listed in front of the metal.
- 3) in formulas with hydride ligands, the hydride is sometimes listed first. Rules # 1 & 2, however, take precedence over this rule:
 $\text{HRh}(\text{CO})(\text{PPh}_3)_2$ and Cp_2TiH_2
- 4) bridging ligands are usually placed next to the metals in question, then followed by the other ligands (note that rules 1 & 2 take precedence): $\text{Co}_2(\mu\text{-CO})_2(\text{CO})_6$, $\text{Rh}_2(\mu\text{-Cl})_2(\text{CO})_4$, $\text{Cp}_2\text{Fe}_2(\mu\text{-CO})_2(\text{CO})_2$

Common Coordination Geometries

6-Coordinate: *Octahedral* (90° & 180° angles)

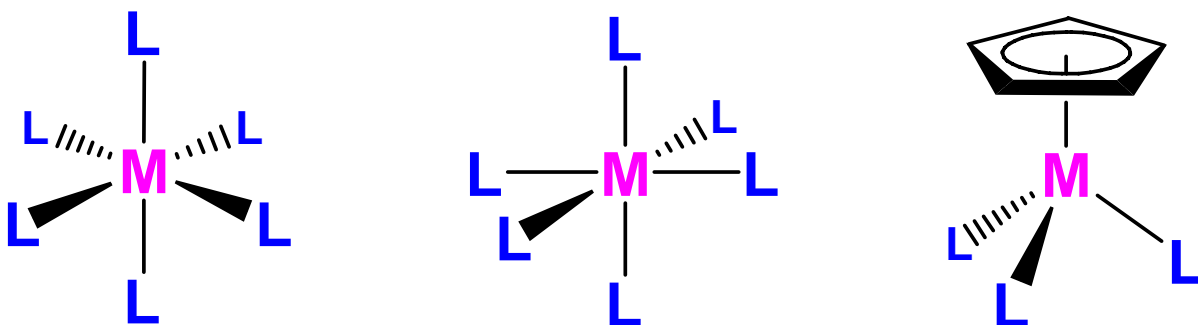

5-Coordinate: *Trigonal Bipyramidal* or *Square Pyramidal*
 (90° & 120°) ($\sim 100^\circ$ & 90°)

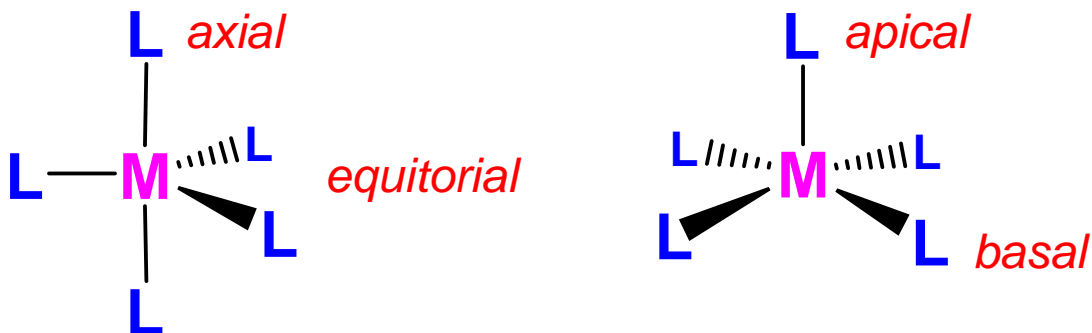

4-Coordinate: *Square Planar* or *Tetrahedral*
 (90° & 180°) (109°)

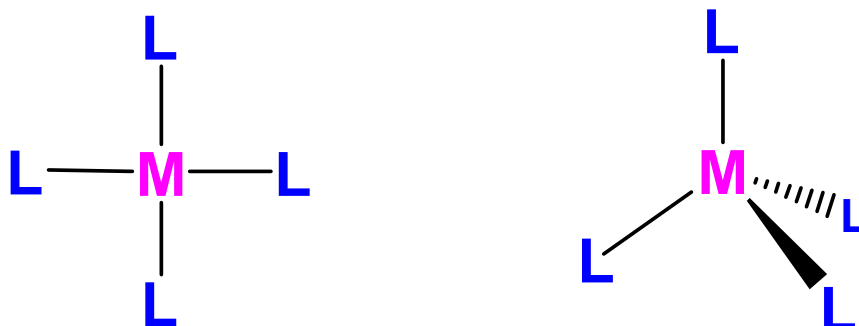

Bonding and Molecular Orbitals

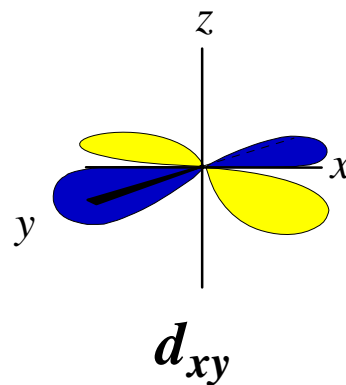
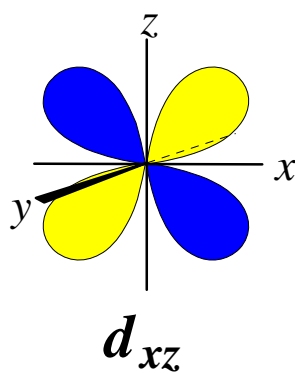
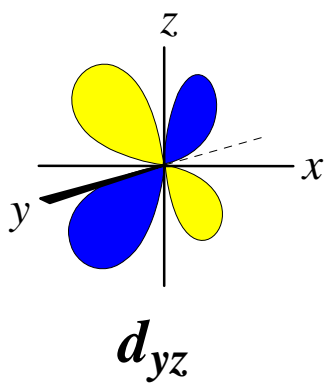
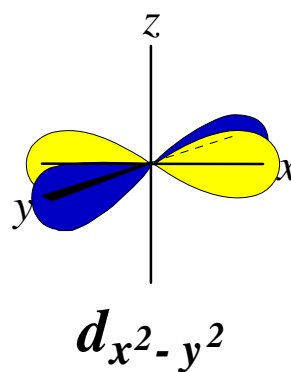
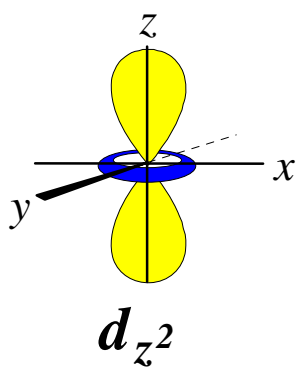
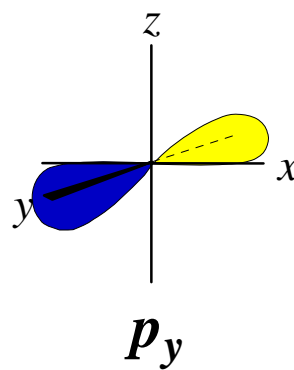
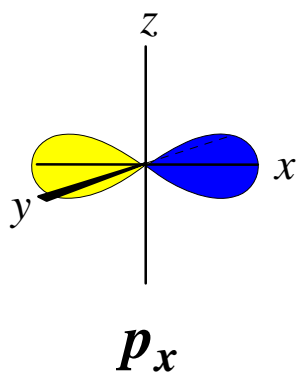
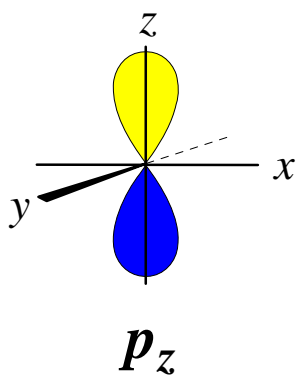
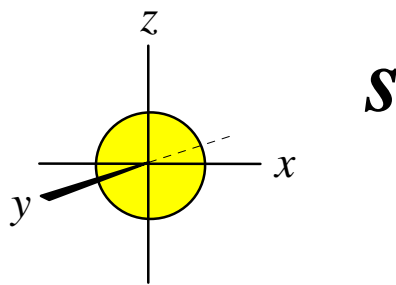

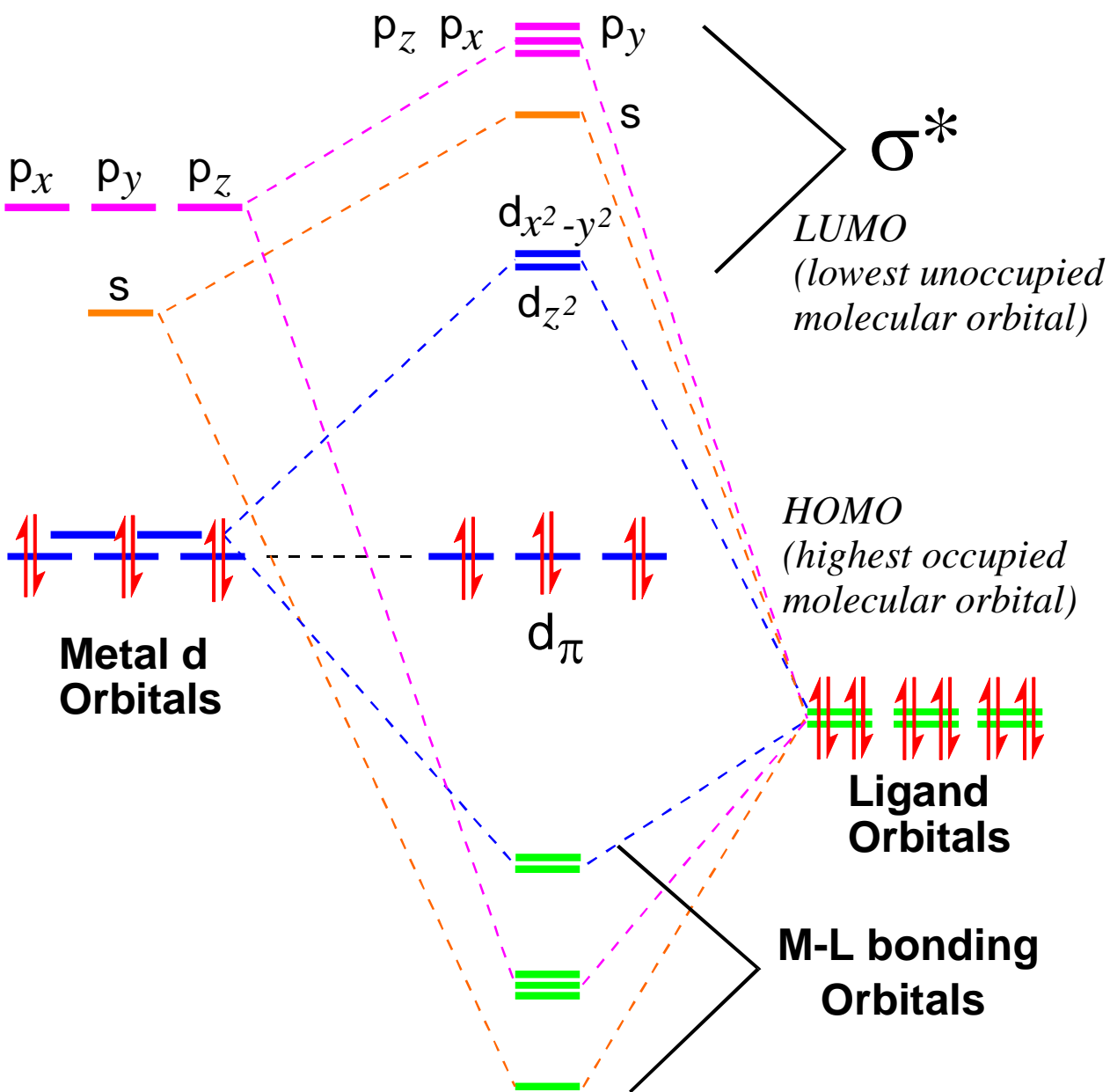
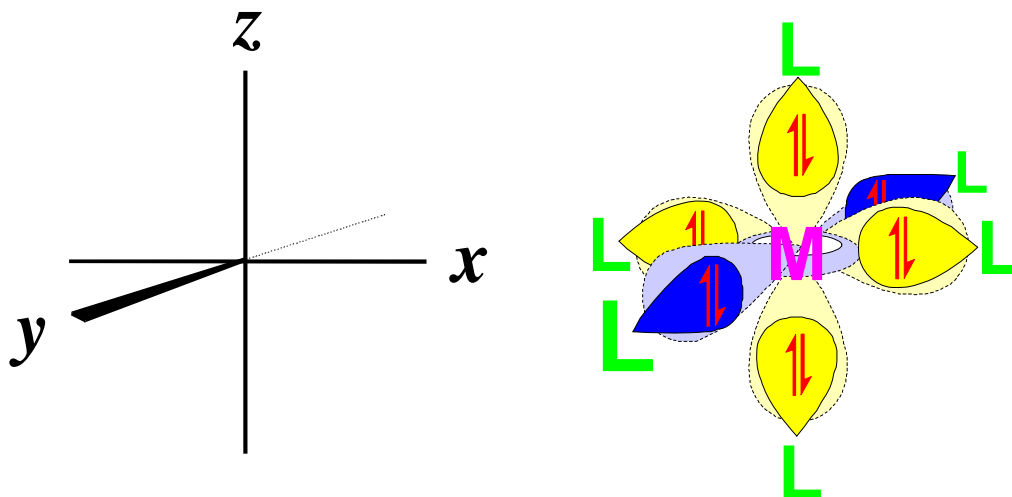

18 Electron "Rule"

Organic compounds, of course, follow the **8 electron rule**: there can only be a maximum of 8 valence electrons around a carbon center.

The vast majority of stable diamagnetic organometallic compounds have 16 or 18 valence electrons due to the presence of the five *d* orbitals which can hold 10 more electrons relative to C, O, N, etc.

Electron counting is the process of determining the number of valence electrons about a metal center in a given transition metal complex.

To determine the electron count for a metal complex:

- 1) **Determine the oxidation state of the transition metal center(s) and the metal centers resulting *d*-electron count. To do this one must:**
 - a) **note any overall charge on the metal complex**
 - b) **know the charges of the ligands bound to the metal center (ionic ligand method)**
 - c) **know the number of electrons being donated to the metal center from each ligand (ionic ligand method)**
- 2) **Add up the electron counts for the metal center and ligands**

Complexes with 18 e- counts are referred to as ***saturated***, because there are no empty low-lying orbitals to which another incoming ligand can coordinate. Complexes with counts lower than 18e- are called ***unsaturated*** and can electronically bind additional ligands.

Exceptions to the 18e “Rule”

Group 8 Metals

d^3	d^4	d^5	d^6	d^7	d^8	d^9	d^{10}	$d^{10}s^1$
21 Sc Scandium	22 Ti Titanium	23 V Vanadium	24 Cr Chromium	25 Mn Manganese	26 Fe Iron	27 Co Cobalt	28 Ni Nickel	29 Cu Copper
39 Y Yttrium	40 Zr Zirconium	41 Nb Niobium	42 Mo Molybdenum	43 Tc Technetium	44 Ru Ruthenium	45 Rh Rhodium	46 Pd Palladium	47 Ag Silver
57 La Lanthanum	72 Hf Hafnium	73 Ta Tantalum	74 W Tungsten	75 Re Rhenium	76 Os Osmium	77 Ir Iridium	78 Pt Platinum	79 Au Gold

Early Transition Metals

16e and sub-16e configurations are common

Coordination geometries higher than 6

Middle Transition Metals

18e configurations are common

Coordination geometries of 6 are common

Late Transition Metals

16e and sub-16e configurations are common

Coordination geometries of 5 or lower



d^6

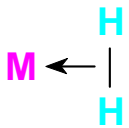
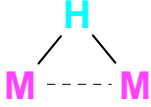
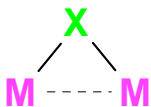
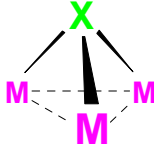
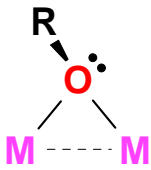
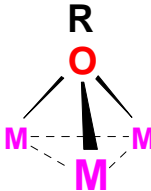
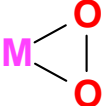
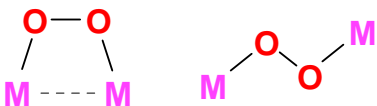

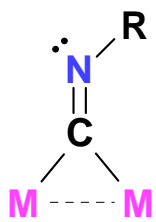
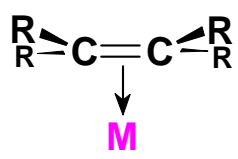
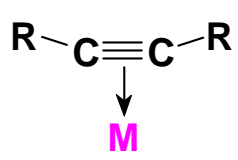
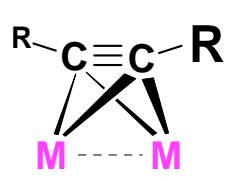

Ligands, Bonding Types, Charges, and Electron Donor Numbers

Ligand Name	Bonding Type	Formal Charge	Electrons Donated
Molecular Hydrogen: H ₂		0	2
Hydride: H ⁻	M-H	-1	2
Hydride: H ⁻		-1	2
Halide: X ⁻	M-X	-1	2
Halide: X ⁻ μ bridging		-1	4 (2 to each M)
Halide: X ⁻ μ ₃ bridging		-1	6 (2 to each M)
Alkoxide, thiolate: OR ⁻ , SR ⁻	M-OR	-1	2 or 4
Alkoxide, thiolate: OR ⁻ , SR ⁻ μ bridging		-1	4 (2 to each M)
Alkoxide, thiolate: OR ⁻ , SR ⁻ μ ₃ bridging		-1	6 (2 to each M)
Peroxide: O ₂ ²⁻ η ²		-2	4
Peroxide: O ₂ ²⁻ μ ₂ bridging		-2	4 (2 to each M)

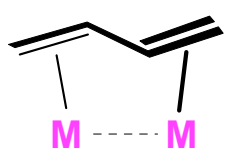
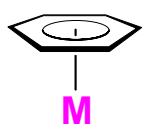
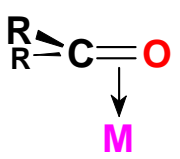
Oxide, sulfide: O^{2-} , S^{2-}	$M=O:$ $M\equiv O:$	-2	4 6
Oxide, sulfide: O^{2-} , S^{2-} μ bridging		-2	4 (2 to each M)
Oxide, sulfide: O^{2-} , S^{2-} μ_3 bridging		-2	6 (2 to each M)
Amine, phosphine, arsine: NR_3 , PR_3 , AsR_3	$M-NR_3$ $M-PR_3$	0	2
Amide, phosphide: NR_2^- , PR_2^-		-1	2 4
Amide, phosphide: NR_2^- , PR_2^- μ bridging:		-1	4 (2 to each M)
Imido: NR^{2-}	$M=N-R$ $M\equiv N-R$	-2	4 (bent) 6 (linear)
Imido: NR^{2-} μ bridging		-2	4 or 6 (2 or 3 to each M)
Imido: NR^{2-} μ_3 bridging		-2	6 (2 to each M)
Nitride, phosphide: N^{3-} , P^{3-}	$M\equiv N:$	-3	6

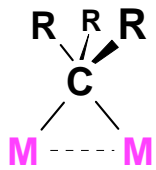
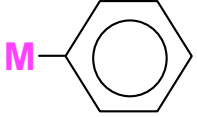
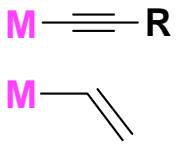
Nitride, phosphide: N^{3-} , P^{3-} , μ bridging		-3	4 or 6 (2 or 3 to each M)
Nitride, phosphide: N^{3-} , P^{3-} , μ_3 bridging		-3	6
Nitrosyl: $N\equiv O^+$ <i>linear form</i>	$M-N\equiv O$	+1	2
Nitrosyl: $N\equiv O^-$ <i>bent form</i>		-1	2
Nitrosyl: $N\equiv O^+$ μ bridging		+1	1 to each metal
Nitrosyl: $N\equiv O^+$ μ_3 bridging		+1	1 to each metal
Carbonyl: $C\equiv O$	$M-C\equiv O$	0	2
Carbonyl: $C\equiv O$ μ, η^2 mode		0	2 to each metal
Carbonyl: $C\equiv O$ μ bridging		0	1 to each metal
Carbonyl: $C\equiv O$ μ_3 bridging		0	1 to each metal

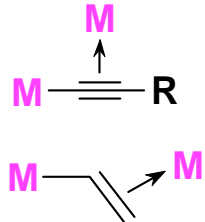
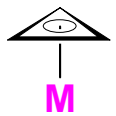
Isocyanide: $C\equiv N-R$	$M-C\equiv N-R$	0	2
Isocyanide: $C\equiv N-R$ μ bridging		0	1 to each metal
Alkene: $R_2C=CR_2$ η^2 bonding mode		0	2
Alkyne: $RC\equiv CR$ η^2 bonding mode		0	2 or 4
Alkyne: $RC\equiv CR$ μ bridging		0	2 to each metal
Dienes: $R_2C=CH-CH=CR_2$ η^4 bonding mode		0	4
Dienes: $R_2C=CH-CH=CR_2$ μ bridging		0	2 to each metal
Benzene: C_6H_6 η^6 bonding mode		0	6
Ketones, aldehydes: η^2 bonding mode		0	2
Alkyl: CH_3^- , CH_2R^- η^1 bonding mode	$M-CR_3$	-1	2

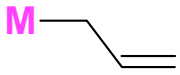
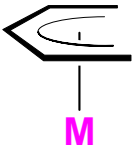
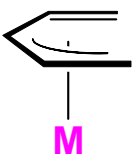
Alkyl: CH_3^- , CH_2R^-		-1	2 (1 to each M) <i>assuming no agostic M-H interactions</i>
Aryl: C_6H_5^- η^1 terminal		-1	2
Alkenyl (vinyl), alkynyl: $\text{CH}=\text{CH}_2^-$, $\text{C}\equiv\text{CH}^-$ η^1 terminal		-1	2
Alkenyl (vinyl): $\text{CH}=\text{CH}_2^-$ η^2 terminal		-1	4
Alkenyl (vinyl), alkynyl: $\text{CH}=\text{CH}_2^-$, $\text{C}\equiv\text{CH}^-$ μ, η^2 terminal		-1	4 (2 to each M)
Cyclopropenyl: C_3H_3^- η^3 terminal		-1	4
Allyl: C_3H_5^- η^3 terminal		-1	4
Allyl: C_3H_5^- η^1 terminal		-1	2
Pentadienyl: C_5H_7^- η^5 terminal		-1	6
Pentadienyl: C_5H_7^- η^3 terminal		-1	4

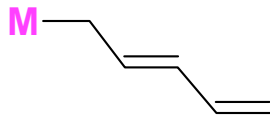
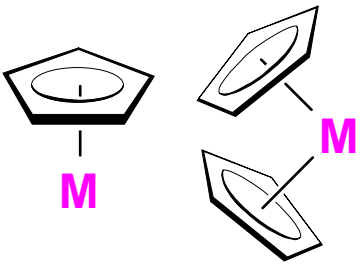
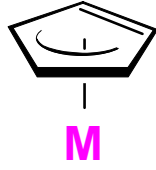
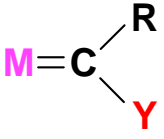
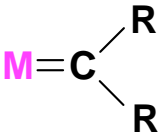
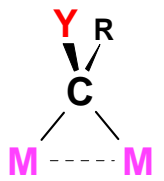
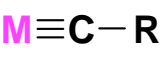
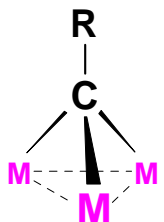
Pentadienyl: $C_5H_7^-$ η^1 terminal		-1	2
Cyclopentadienyl: $C_5H_5^-$ η^5		-1	6
Cyclopentadienyl: $C_5H_5^-$ η^3		-1	4
Carbene: $=CYR$ <i>where Y is a substituent capable of π interaction with the carbene carbon atom</i>		0	2
Alkylidene: $=CR_2^{2-}$ <i>where no substituents capable of π bonding to the carbene carbon atom are present</i>		-2	4
Carbene: $=CYR$ or $=CR_2^{2-}$ μ bridging		-2	2 to each metal
Carbyne or Alkyidyne: $\equiv CR^{3-}$		-3	6
Carbyne or Alkyidyne: $\equiv CR^{3-}$ μ_3 bridging		-3	2 to each metal

How do I Figure Out Ligand Charges & Donor #'s ?? (without memorizing that !#&!@%\$* entire list)

First, you should know the charges and donor # for the **common** ligands (this will significantly speed up your counting):

Cationic 2e- donor: NO^+ (nitrosyl)

Neutral 2e- donors: PR_3 (phosphines), CO (carbonyl), $\text{R}_2\text{C}=\text{CR}_2$ (alkenes), $\text{RC}\equiv\text{CR}$ (alkynes, can also donate 4 e-), $\text{N}\equiv\text{CR}$ (nitriles)

Anionic 2e- donors: Cl^- (chloride), Br^- (bromide), I^- (iodide), CH_3^- (methyl), CR_3^- (alkyl), Ph^- (phenyl), H^- (hydride)

The following can also donate 4 e- if needed, but initially count them as 2e- donors (unless they are acting as bridging ligands): OR^- (alkoxide), SR^- (thiolate), NR_2^- (inorganic amide), PR_2^- (phosphide)

Anionic 4e- donors: C_3H_5^- (allyl), O^{2-} (oxide), S^{2-} (sulfide), NR^{2-} (imide), CR_2^{2-} (alkylidene)

and from the previous list: OR^- (alkoxide), SR^- (thiolate), NR_2^- (inorganic amide), PR_2^-

Anionic 6e- donors: Cp^- (cyclopentadienyl), O^{2-} (oxide)

Please note that we are using the **Ionic Method** of electron-counting. 95% of inorganic/organometallic chemists use the ionic method. The ionic method assigns formal charges to the metal and ligands in order to keep the ligands with an even # of electrons and (usually) a filled valence shell. There is also the **neutral method** that considers everything to be neutral. Synthetically, the ionic method generally makes more sense and the one that we will use in this course.

Simple Example:

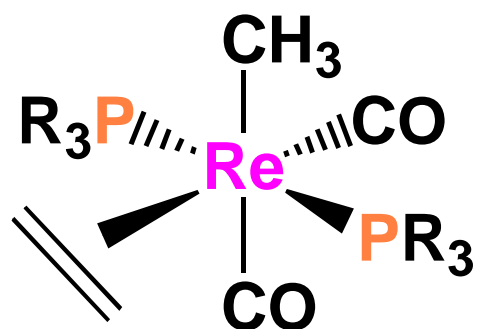

- 1) There is no overall charge on the complex
- 2) There is one anionic ligand (CH_3^- , methyl group)
- 3) Since there is no overall charge on the complex (it is neutral), and since we have one anionic ligand present, the Re metal atom must have a +1 charge to compensate for the one negatively charged ligand. The +1 charge on the metal is also its oxidation state. So the Re is in the +1 oxidation state. We denote this in two different ways: $\text{Re}(+1)$, $\text{Re}(\text{I})$, or Re^{I} . I prefer the $\text{Re}(+1)$ nomenclature because it is clearer. Most chemistry journals, however, prefer the Roman numeral notation in parenthesis after the element.

Now we can do our electron counting:

$\text{Re}(+1)$	d^6
2 PR_3	4e-
2 CO	4e-
CH_3^-	2e-
$\text{CH}_2=\text{CH}_2$	2e-
<hr/>	
Total:	18e-

Next Electron-Counting Example:

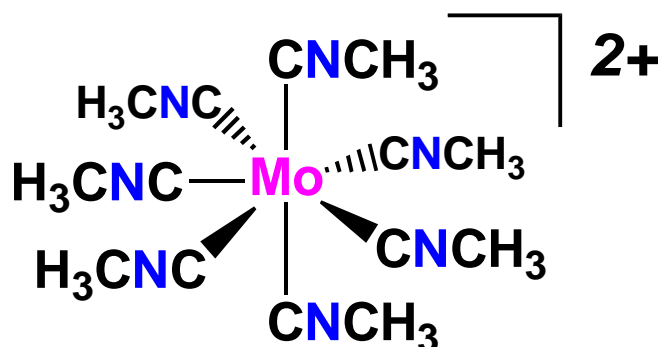

- 1) There is a +2 charge on the complex
- 2) The CNCH₃ (methyl isocyanide) ligand is neutral, but let's check the Lewis Dot structure to make sure that is correct:

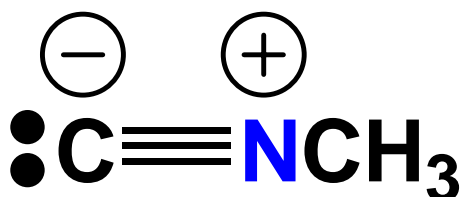

Nitrogen is normally trivalent, that is, it wants to have 3 chemical bonds to it. When it has 4 bonds, one more than usual, the nitrogen atom is assigned a formal *positive* charge. Carbon, on the other hand, is tetravalent and almost always wants 4 bonds. In isocyanides, however, we only have 3 bonds to the C. To keep an even number of electrons around the C we add an extra electron and the carbon gains a formal *negative* charge.

- 3) Because there is a +2 charge on the complex and there are all neutral ligands present, the Mo has a +2 charge & oxidation state.

Now we can do our electron counting:

Mo(+2)	d⁴
7 CNCH ₃	14e-
Total: 18e-	

More Complicated Ligand Analysis:

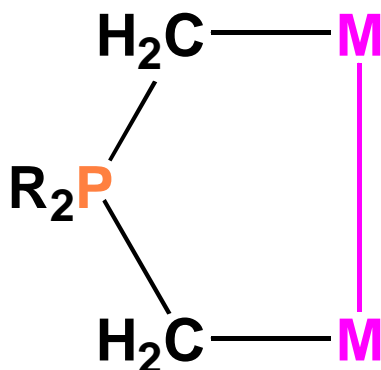

How do we figure out the charge and electron donor ability of this weird ligand??

1) Remove the metal atoms and examine the ligand by itself:

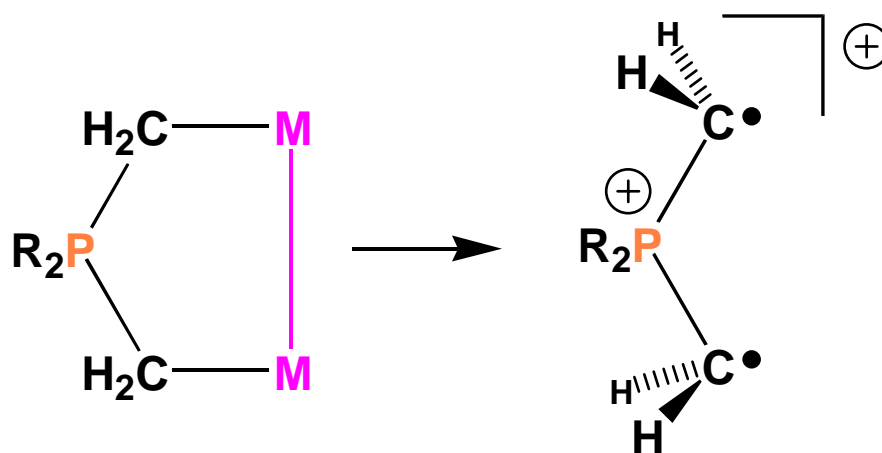

Phosphorus is trivalent and since it has four bonds to it, there is a formal positive charge assigned to the atom. Each carbon is currently neutral and has an odd electron.

2) We always want the ligand in the ionic method of ligand electron counting to have an *even # of electrons*. IF the ligand atom has an odd # of electrons, add enough electrons to get to an even # (and usually a filled valence shell). This usually means adding one electron. In this specific case we have two carbon atoms each which needs an additional electron to give a lone pair that can donate to the metal center:

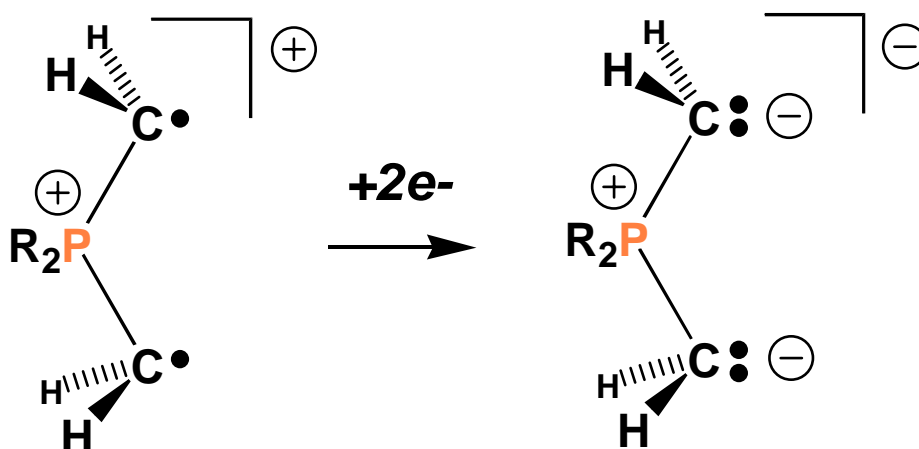

Adding two electrons to this ligand generates two anionic carbon donor centers. *But remember that we have a positive charge on the phosphorus atom*, which although not involved in bonding to the metal, is part of the overall charge of the ligand. So two negative charges and one positive charge (on the phosphorus) yields a net negative charge on this ligand. Each carbon can donate 2 e⁻ to each metal center.

This strange ligand is called a phosphorus di-ylide and is a strongly donating ligand for bridging two metal centers.

More Complicated Metal Compound Analysis:

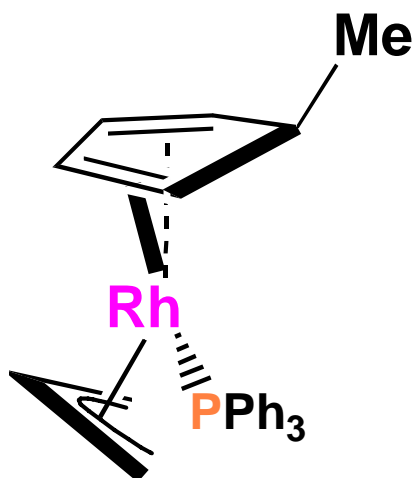

- 1) There is no overall charge on the complex
- 2) There is one anionic ligand ($\eta^3\text{-C}_3\text{H}_5^-$, allyl).

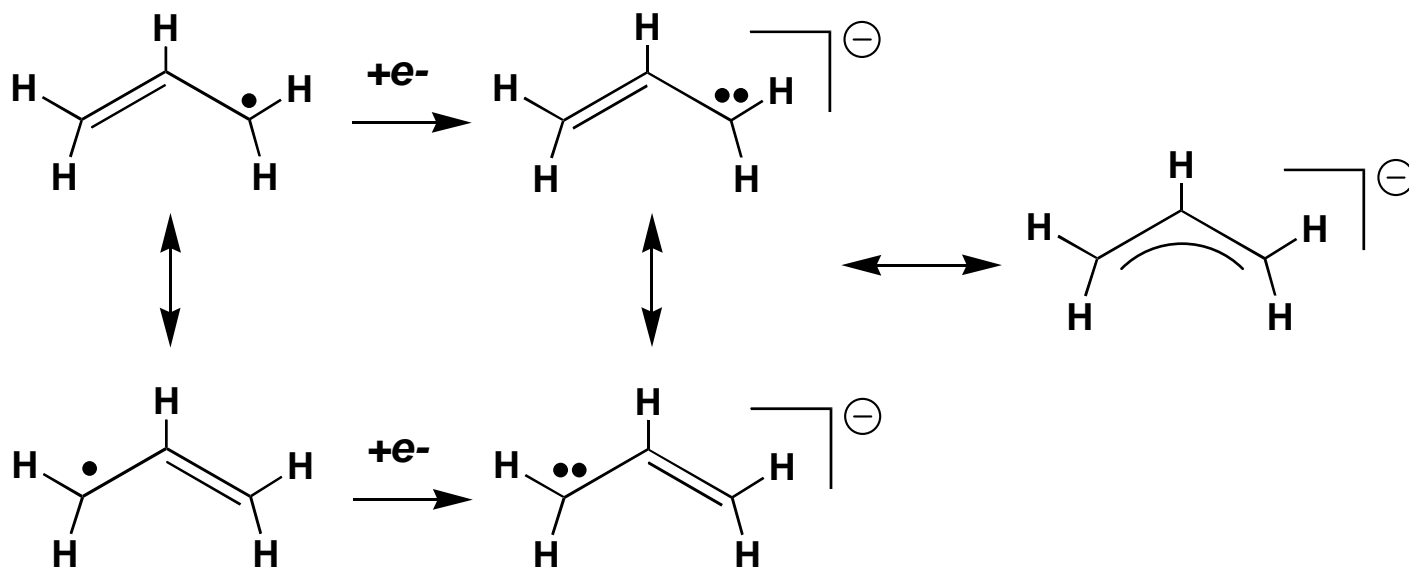

Rule of Thumb: π -based carbon ligands that have odd number attachments to the metal center are usually anionic (except for CO and CNR [isocyanide] ligands) and donate one more electron than the number of carbons bonded to the metal center. So our $\eta^3\text{-C}_3\text{H}_5^-$, allyl ligand is anionic and donates 4e⁻ to the metal center.

The C_5H_5Me ligand is NOT a simple anionic cyclopentadienyl ligand. It is a neutral ligand with two alkenes that each act as neutral $2e^-$ donors to the metal:

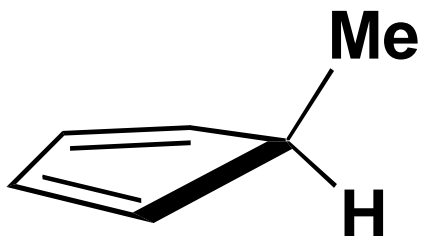

If you work out the Lewis Dot structure for this ligand you get an even # of electrons so there is no need to add an electron to get an anionic ligand. Note that it is EASY to forget that there is a H on the Cp carbon that has the methyl group attached if you are not thinking about organic line notation.

- 3) Because the complex is neutral and there is one anionic ligand present, the Rh atom must have a +1 charge to compensate for the one negatively charged ligand. So the Rh atom is in the +1 oxidation state.

Now we can electron-count:

Rh(+1)	d⁸
PR₃	2e⁻
η^4-C₅H₅Me	4e⁻
η^3-C₃H₅⁻	4e⁻
<hr/>	
Total:	18e⁻

Metal-Metal Bonded Example:

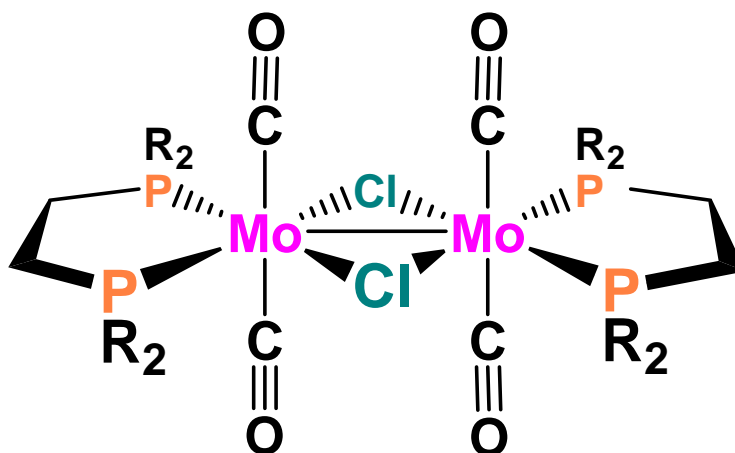

At this point we will consider metal-metal (M-M) bonds to be simple covalent bonds with each metal contributing $1e^-$ to the bond. Most M-M bonded complexes are symmetrical, which means that one only has to e^- count one metal center. If the metals are different, however, one does need to figure out each metal center.

The simple rule for M-M bonding is that if you have two metal atoms next to one another and each has an odd electron-count, you pair the odd electrons to make a M-M bond. This is electron-counted as a $1e^-$ donation from one metal to the other.

This example also has μ -Cl ligands. **Bridging ligands with at least 2 lone pairs almost always donate $2e^-$ to each metal center.**

Oxidation state determination: There are a total of two anionic ligands for two metal centers (overall complex is neutral). Thus each metal center needs to have a +1 oxidation state to balance the anionic ligands.

Common Mistake: Students determining the oxidation state for complexes with 2 or more metal centers often add up all the anionic ligands and then figure out the oxidation state for only one of the metal centers based on this. You need to take into account the charge (if any) on the complex and divide up the anionic ligand charges between all the metal centers present. Each metal in the complex shown above is in the +1 oxidation state – NOT +2.

Now we can electron-count:

Note that each bridging chloride is donating 2e⁻ to each Mo center. Although we only "allocate" one negative charge for figuring out the oxidation state of the Mo atom, one needs to include in the electron-counting the fact that both chlorides are donating electrons to each metal center.

Mo(+1)	d⁵
2PR₃	4e⁻
2CO	4e⁻
2μ-Cl⁻	4e⁻
<i>Sub-total:</i>	
	17e⁻
	Mo-Mo 1e⁻
TOTAL:	18e⁻

This structure is called an edge-sharing bioctahedron (i.e., two octahedral metal centers sharing a common edge).

Another Metal-Metal Bonded Example:

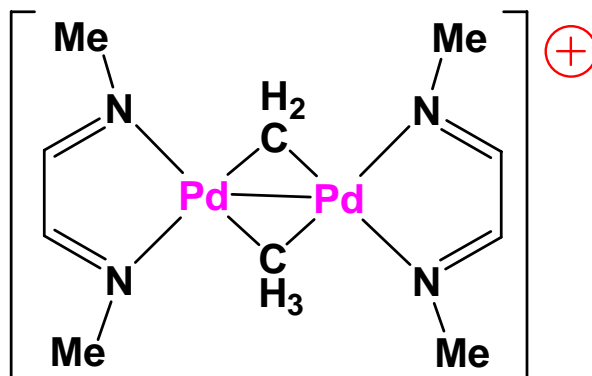

Ligand analysis: The chelating N ligand is a bis-imine, is neutral, with each N atom donating $2e^-$. There are two different bridging ligands – an anionic CH_3^- (methyl group) and a dianionic CH_2^{2-} (carbene or alkylidene). The CH_3^- only has one lone pair of electrons, so it has to split these between the two metals ($1e^-$ to each). The CH_2^{2-} alkylidene ligand, on the other hand, has 2 lone pairs so it can donate $2e^-$ to each metal center.

Oxidation state analysis: There are a total of 3 negative charges on the ligands (anionic methyl, dianionic alkylidene) and a positive charge on the complex. Therefore the two Pd centers must have a TOTAL of a +4 charge, or a +2 charge (oxidation state) on each.

Pd(+2)	d^8
2 imines	$4e^-$
$\mu\text{-CH}_3^-$	$1e^-$
$\mu\text{-CH}_2^{2-}$	$2e^-$
<hr/>	
<i>Sub-total:</i>	$15e^-$
Pd-Pd	$1e^-$
TOTAL:	$16e^-$

Note that Pd(+2) is generally happy with a $16e^-$ configuration.

Problems in Electron Counting

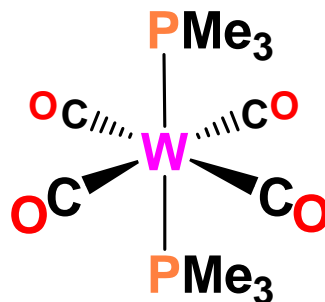
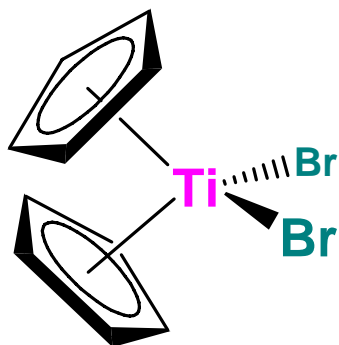
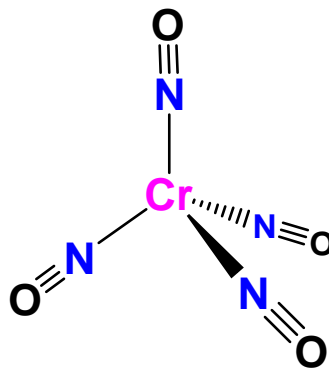
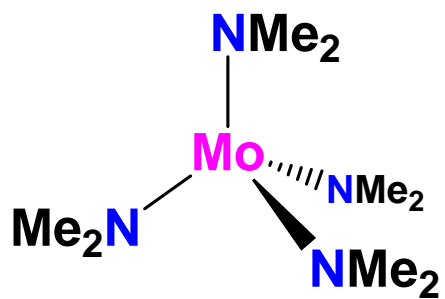
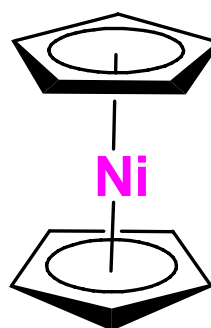
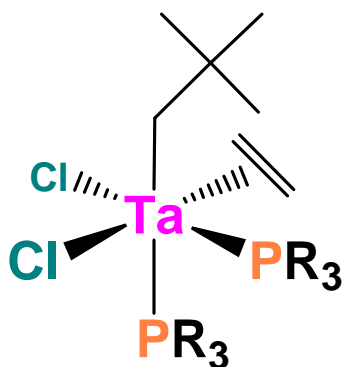
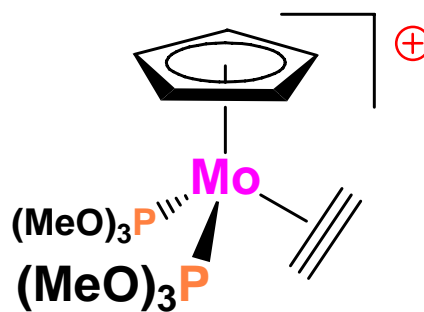
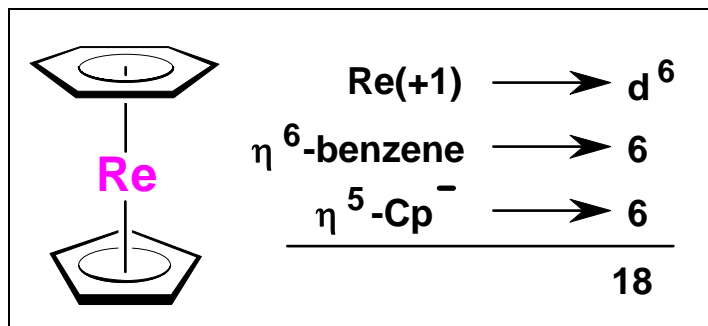

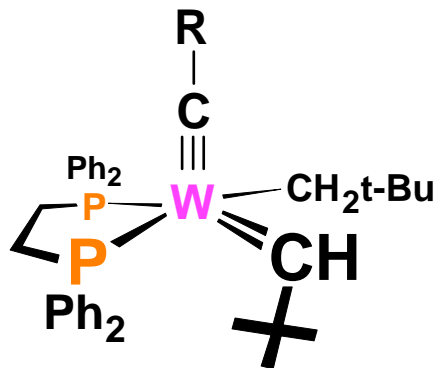
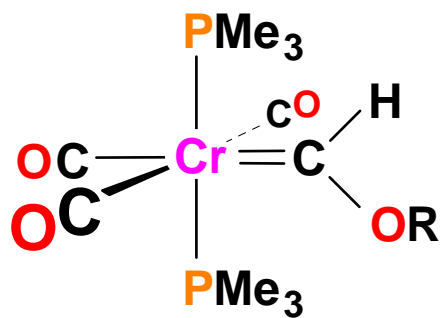
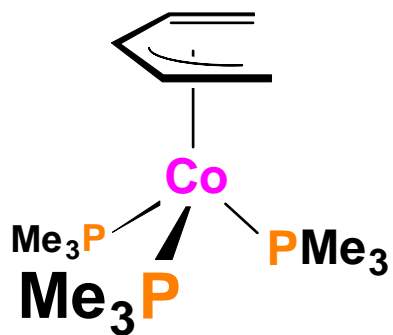
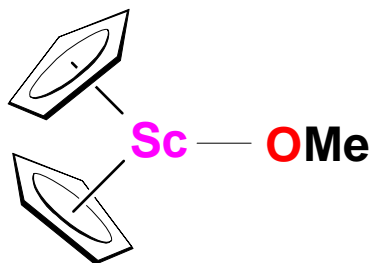
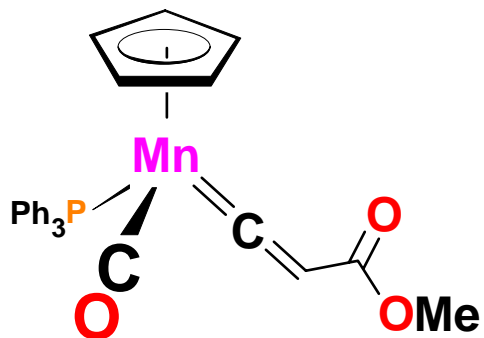
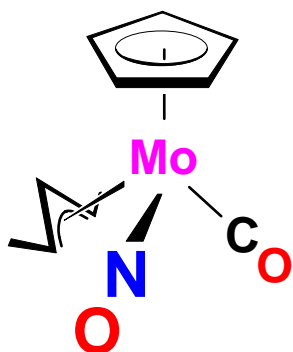
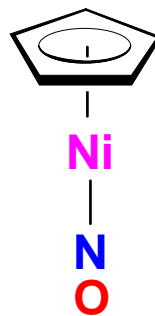
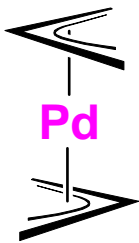

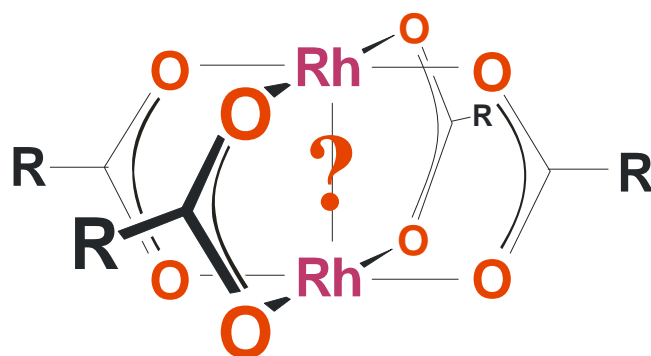
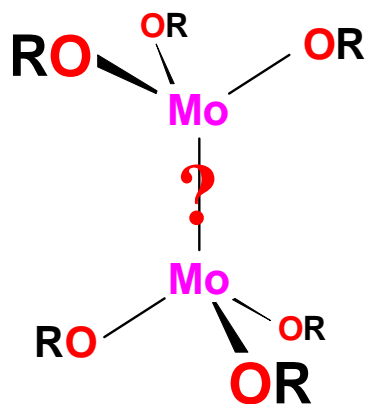
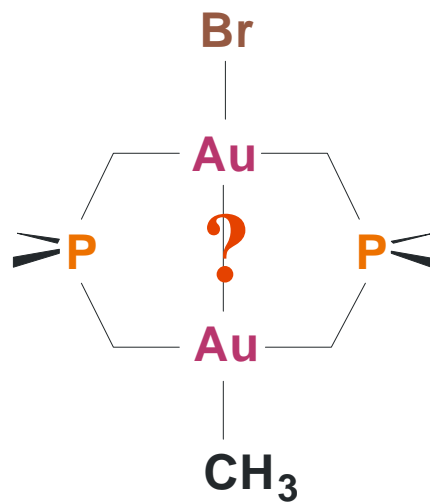
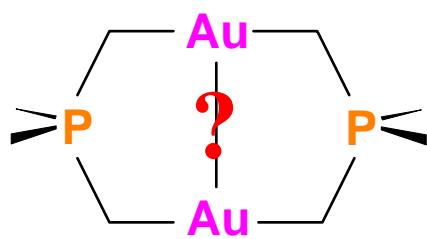
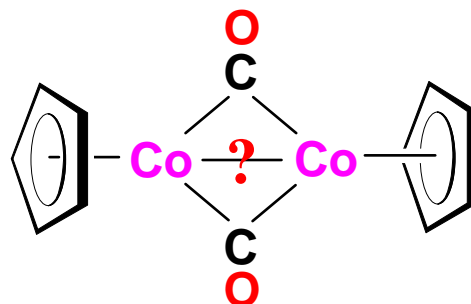
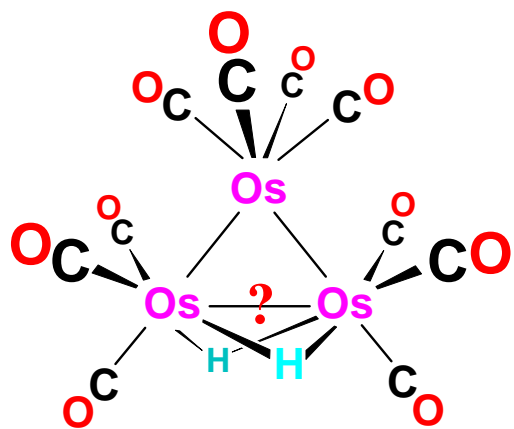
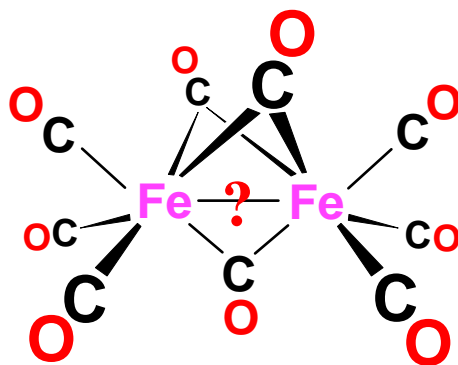
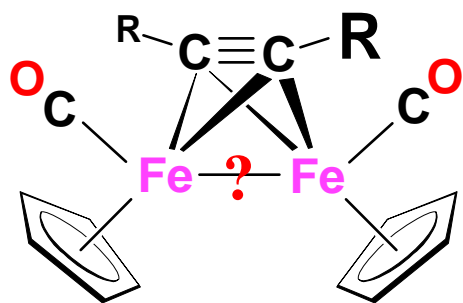

Why is Electron Counting Important??

One of the complexes drawn in the cycle below is highly unlikely and studies have shown that it does not exist (as far as we can tell).

Cotton & Wilkinson, 3rd Edition (1972)

792

CHEMISTRY OF THE TRANSITION ELEMENTS

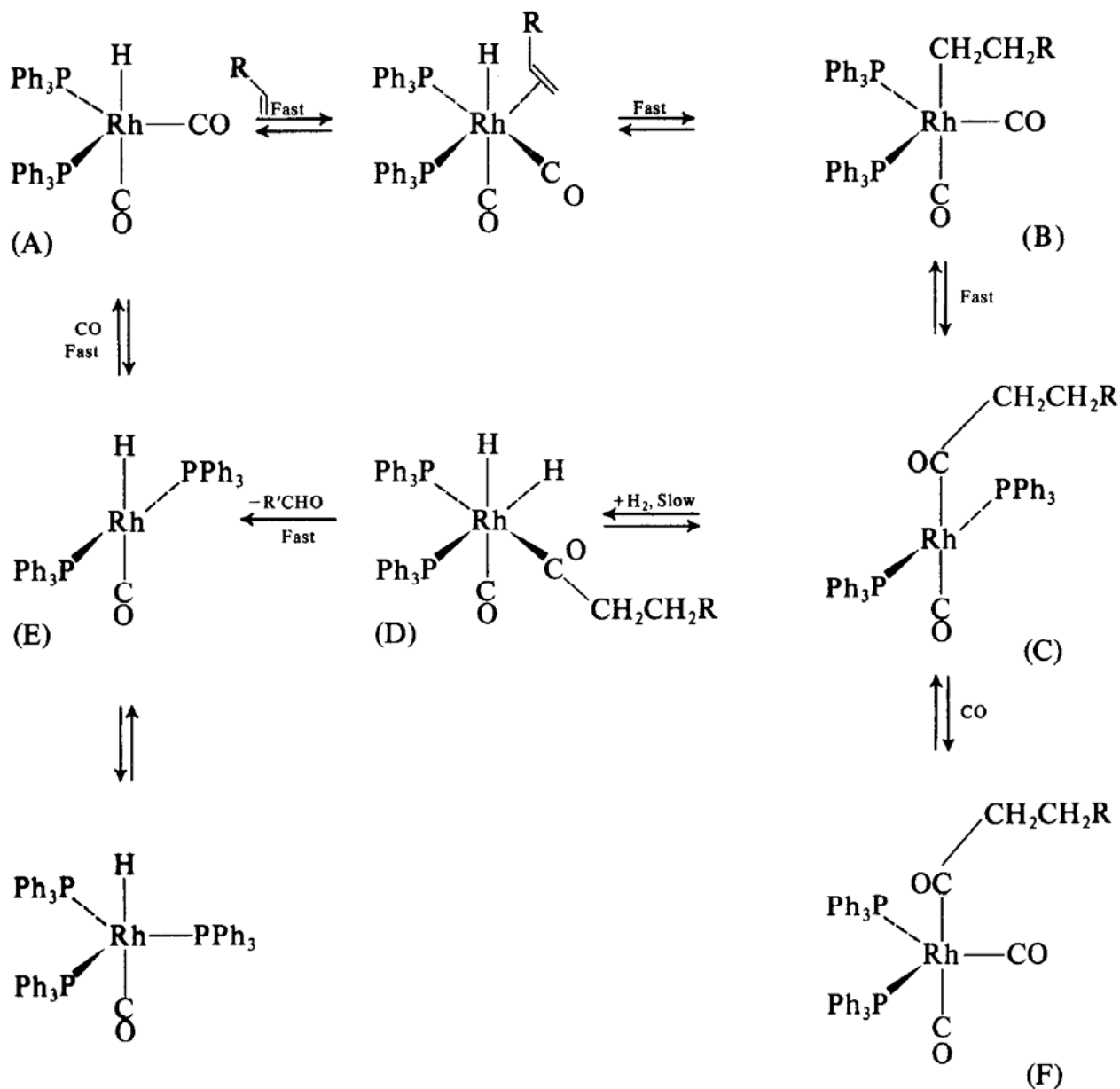

Fig. 24-B-2. Catalytic cycle for the hydroformylation of alkenes involving triphenylphosphine rhodium complex species. Note that the configurations of the complexes are not known with certainty.

Lewis Base Ligands

Non-carbon donor ligands that have one or more lone pairs of e⁻ that can be donated into empty orbitals on the metal center.

Although *phosphine* ligands (PR₃) are formally Lewis Base ligands, their importance in organometallic chemistry is such that we will treat them separately later.

Halide Donors

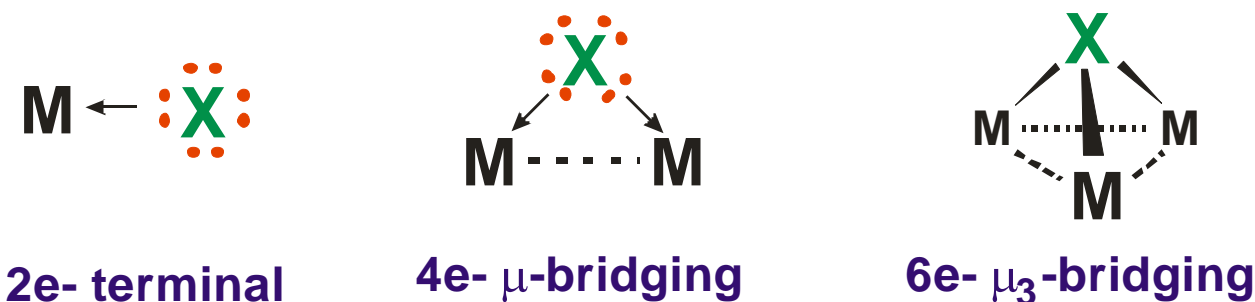
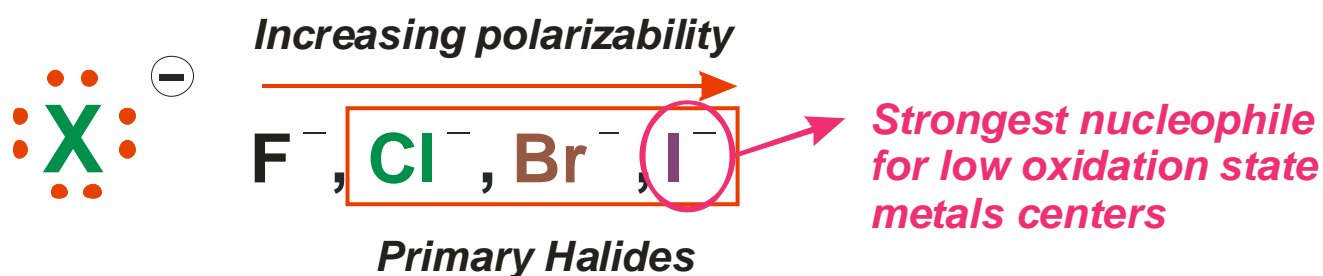

The halides are anionic donors that generally only donate 2e⁻ to a metal center. Due to their relatively high

electronegativity they are not especially good σ-donor ligands.

Although they can theoretically act as π-donor ligands, once again, the higher electronegativity limits them to simple 2e⁻ donor ligands.

Fluoride is generally NOT a good ligand except for very high oxidation state metal centers. It is too electronegative to donate much of its electron density to a "normal" metal center.

One possible exception to the 2e- donor “*rule*” when they are coordinating to a single metal center is for **iodide**. It is the least electronegative of the halides (not counting astatine) and is the best donor group. This is some evidence that **iodide** is a good enough donor and has enough orbital extension to act as a 4e- σ - and π -donor in some cases.

Common Misconception: Since we treat the halides as anionic halide ligands their relatively high electronegativity does NOT make them electron-withdrawing ligands as thought of in organic chemistry. In organic chemistry the halogens are treated as neutral ligands and as such drain electron density from whatever they are attached to. But in inorganic and organometallic chemistry they are anionic and are perfectly happy with that charge. What their electronegativity does in organometallic chemistry is to **NOT** make the halides particularly good donor ligands. As one moves down the periodic table from F^- to I^- , we do see steadily increasing donor ability as the electronegativity drops.

When halides act as bridging ligands (relatively common) they donate 2e- to each metal center that they are coordinated to.

Oxygen Donors



Alkoxides

2 or 4e- donor

Terminal
Bridging
Triply bridging



Oxide

4 or 6e- donor

Terminal
Bridging
Triply bridging
Quad bridging

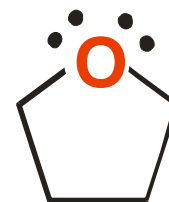

THF
tetrahydrofuran

Ethers

2e- donor

Typically
weak donor

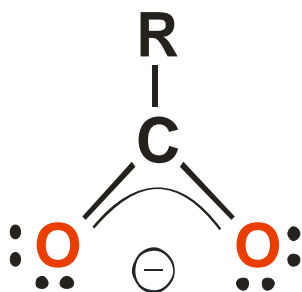

Carboxylates

2 or 4e- donor

η^1 -terminal
 η^2 -terminal
Bridging

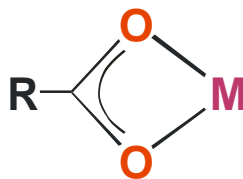

η^2 -chelating 4e-

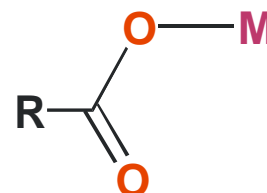

η^1 2e- mode

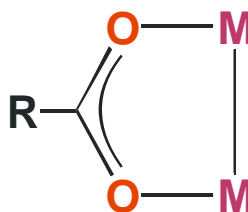

μ -bridging

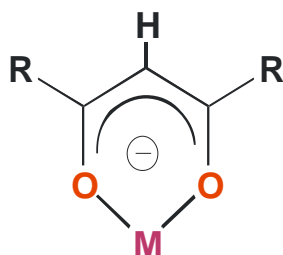

Acetoacetonates (acac)

2 or 4e- donor

*Unusual C-bonded
acac*



Sulfur Ligands



2e- or 4e- Terminal
4e- Bridging
6e- Triply bridging

*Easily oxidized
to R-S-S-R*

Thiolates
Mercaptides

Thiolates are powerful bridging ligands, particularly for low-oxidation state metal centers. The lower electronegativity relative to oxygen means that thiolates are also better donors.



4e- Terminal
4e- Bridging
6e- Triply bridging
8e- Quad bridging

$\text{M}=\text{S}$ *Relatively*
 $\text{M}\equiv\text{S}$ *rare*

Sulfide

Sulfides (and thiolates) are extremely effective bridging ligands and play a critically important role as such in bioinorganic chemistry:

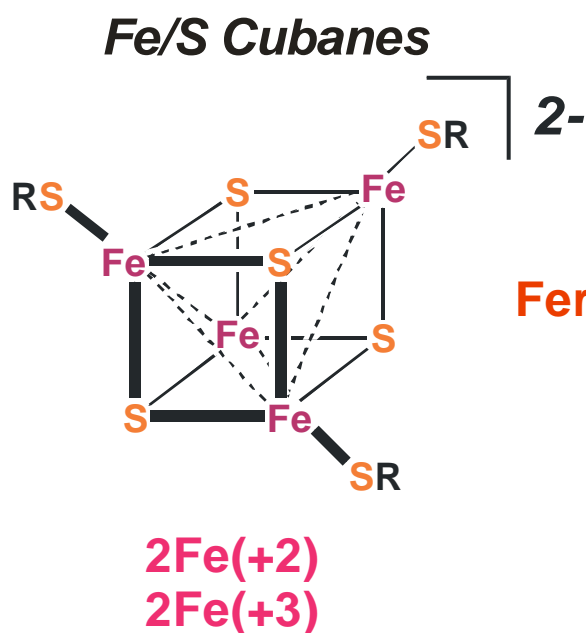

Ferredoxins

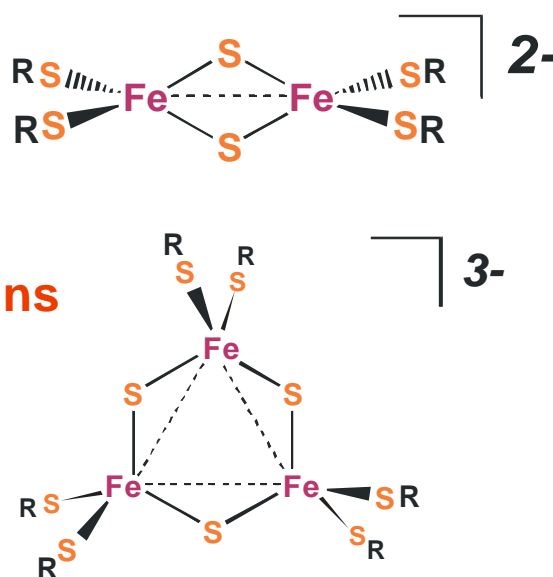

Nitrogenase

The nitrogenase enzyme catalyzes the extremely difficult reaction:

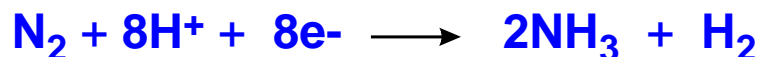

The conversion of atmospheric N_2 into NH_3 is a marvel of catalysis and provides the plant with its own fertilizer. In the **Haber** catalytic process for converting $\text{N}_2 + 3\text{H}_2$ into NH_3 , over 400°C and 400 atm of H_2/N_2 pressure are required along with a heterogeneous Fe catalyst. Nitrogenase does this at room temperature and pressure.

Nitrogenase, shown to the right, requires a steady source of electrons. The reaction requires the addition of 8 electrons for each nitrogen molecule that is split into two NH_3 molecules and one “wasted” H_2 . The Fe protein (green) uses the breakage of ATP to pump these electrons into the MoFe protein (blue-purple). Two molecules of ATP are consumed for each electron transferred.

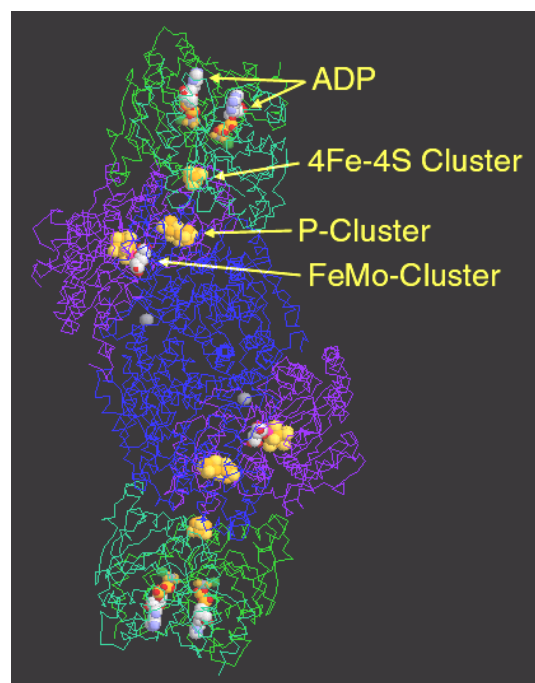

The active catalytic site in the enzyme is believed to be this unusual Fe/Mo/S cluster – the central atom is believed to be a nitride (N^{3-}), see *Science*, 2002, 297, 1696-1700.

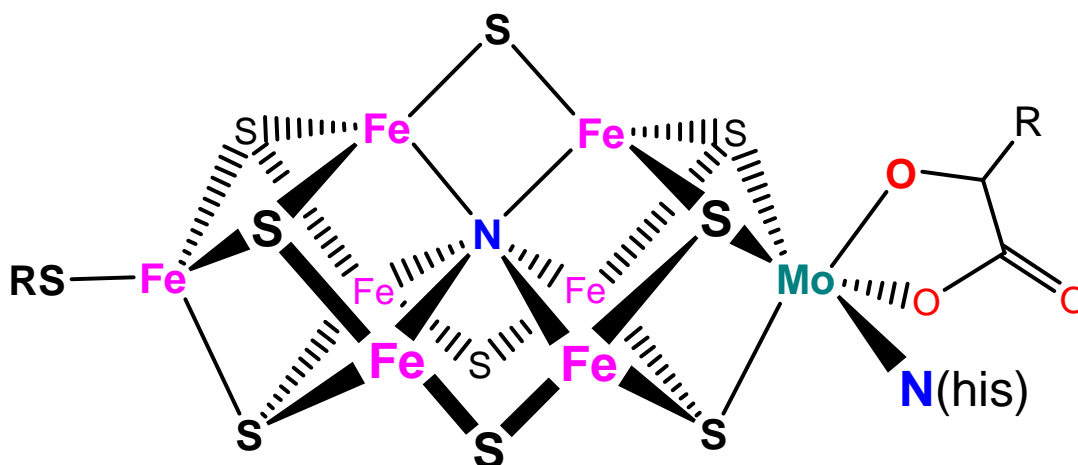

Nitrogen Ligands

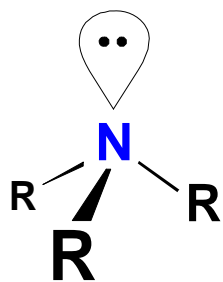

In general, alkylated **amines** are not particularly good ligands. This is mainly due to the relatively short N-C bond distances and the stereoelectronic problems generated from this.

Chelating amines have less steric problems and are better ligands for transition metal centers. Primary and secondary amines, however, are susceptible to oxidations:

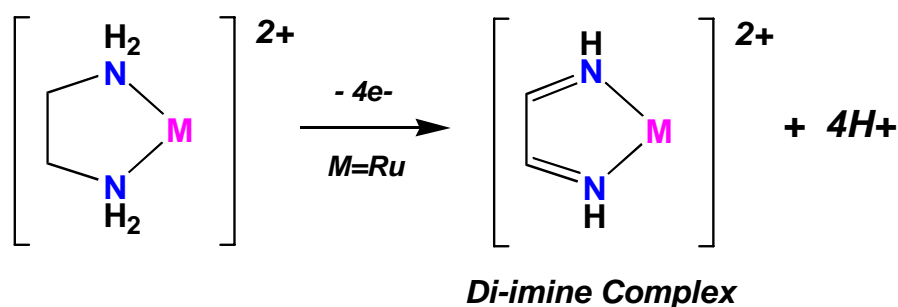

Tertiary amines, on the other hand, are quite stable and not easily oxidized.



TMEDA = tetramethylethylenediamine

Perhaps the most famous neutral **nitrogen** donor ligand is **bipyridine** or **bipyridyl**, almost universally abbreviated **bipy**. Phenanthroline is a more rigid version of bipy that forms even stronger metal chelates.

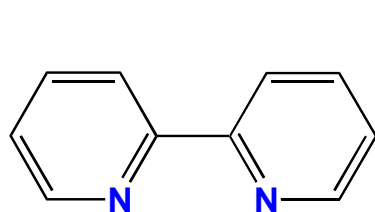

Bipy = Bipyridine

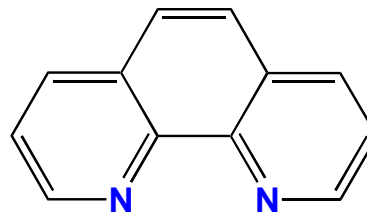

Phen = phenanthroline

The most famous bipy complex is $[\text{Ru}(\text{bipy})_3]^{2+}$, which has an extremely rich photoredox chemistry. There are probably over 1000 papers concerning $[\text{Ru}(\text{bipy})_3]^{2+}$.

Bipy (and its related systems) can stabilize multiple oxidation states on metal complexes:

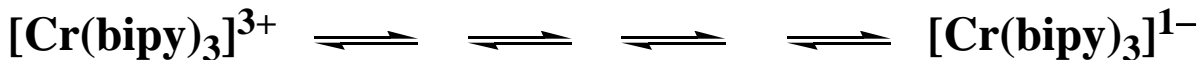
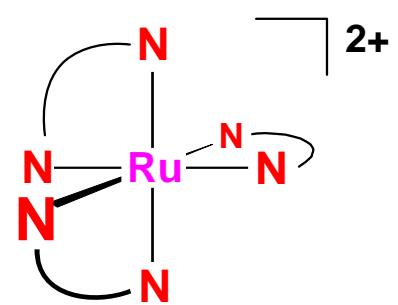

Inorganic Amides

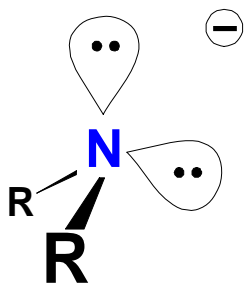

Strong Base & Nucleophile
Terminal (2 or 4e-) donor
4e- Bridging donor

The lone pairs in an amide are about 2eV higher in energy than in OR^- . This makes an amide a considerably stronger donor.

Typical formation reaction:

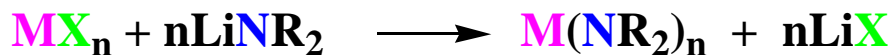

Amides that act as 2e- donors have *pyramidal geometry* (sp^3 -like) with a free lone pair, while amides that donate 4e- have a *trigonal planar* (sp^2 -like) *geometry*. There are, of course, in-between structural cases that indicate intermediate bonding situations.

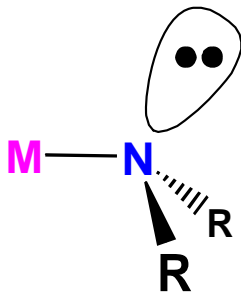

2e- donor
pyramidal geometry

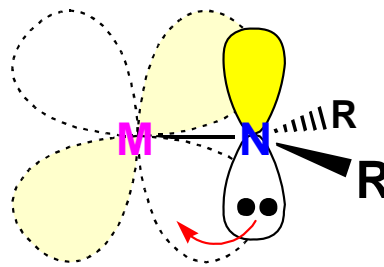

4e- donor
trigonal planar

Alkyl-Imido (nitrene) Ligand

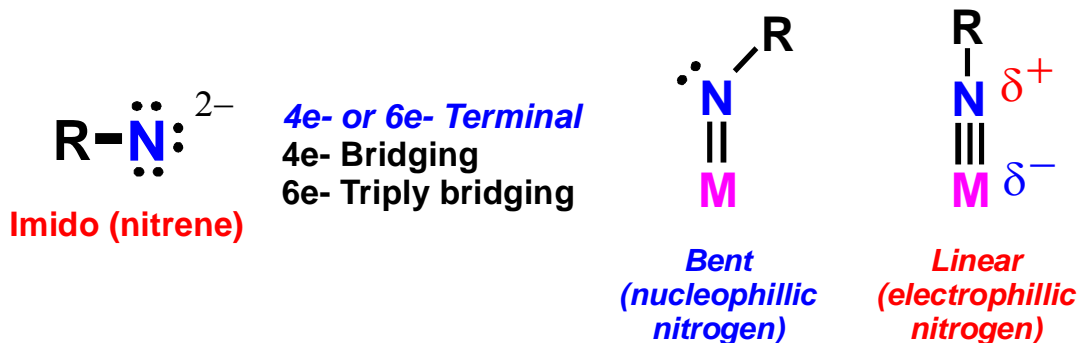

In the **bent** mode the imido ligand is formally only a **4e-** donor, while in the **linear** mode it donates **6e-** to the metal center. As with the other ligands we have seen that can donate variable numbers of electrons to the metal center, you initially count it as a 4e- donor and then boost it up to 6e- if you need to increase the electron count on the metal to get up to 16 or 18 e-.

Some examples:

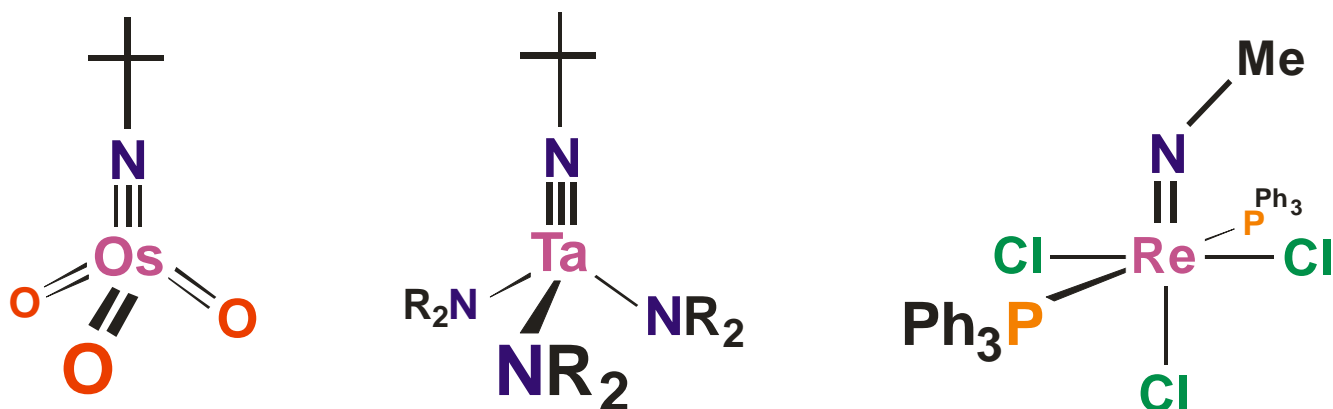

As one moves to the right-hand side of the periodic table, one tends to get less M-L multiple bonding

As with amides, you can have intermediate cases where the bending of the alkyl group is in-between linear and bent. It is difficult to predict when the imido ligand will act as a 4e- or 6e- donor. So long as you give me a reasonable electron count I will not be picky about whether you use 4e- or 6e-. If you use **6e-** you should realize that the imido and alkyl group should be drawn **linear**.

Tris(pyrazolyl)borate Ligand

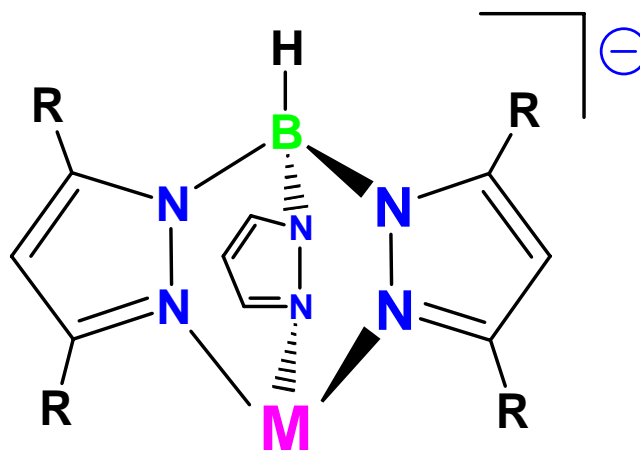

- *Anionic*
- *6e⁻ donor*
- *coordination via the three lower nitrogen centers*
- *Moderate donor*
- *Steric effects adjusted via R groups*

The tris(pyrazolyl)borate (Tp) ligand has become extremely popular in the last decade and is sometimes called the inorganic Cp ligand. It is **anionic** and is a 6e⁻ donor when all three nitrogens are coordinated to a metal center, just like Cp⁻.

It is considerably bulkier (much bulkier if one uses large bottom R groups) and, due to the higher nitrogen electronegativity, it is not as good a donor relative to Cp.

When drawing the ligand, you can abbreviate it as follows:

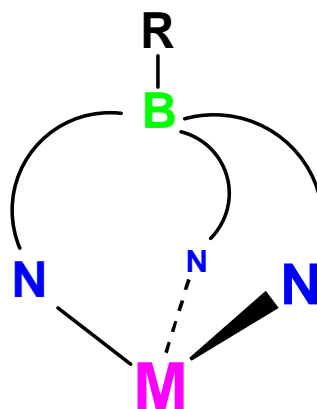

Most inorganic and organometallic chemists will understand what you are talking about with this simplified drawing.

A Few Biologically Important N-Ligands

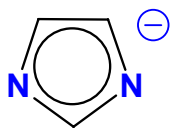
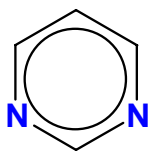
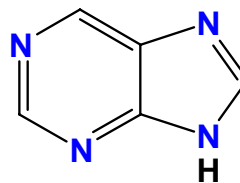
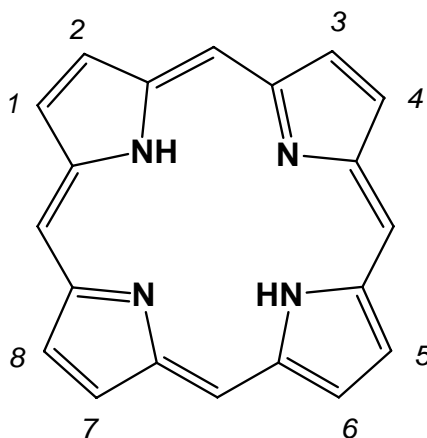
*imidazolate**pyrimidine**purine*

Porphine
(metalloporphyrin when bound to a metal)

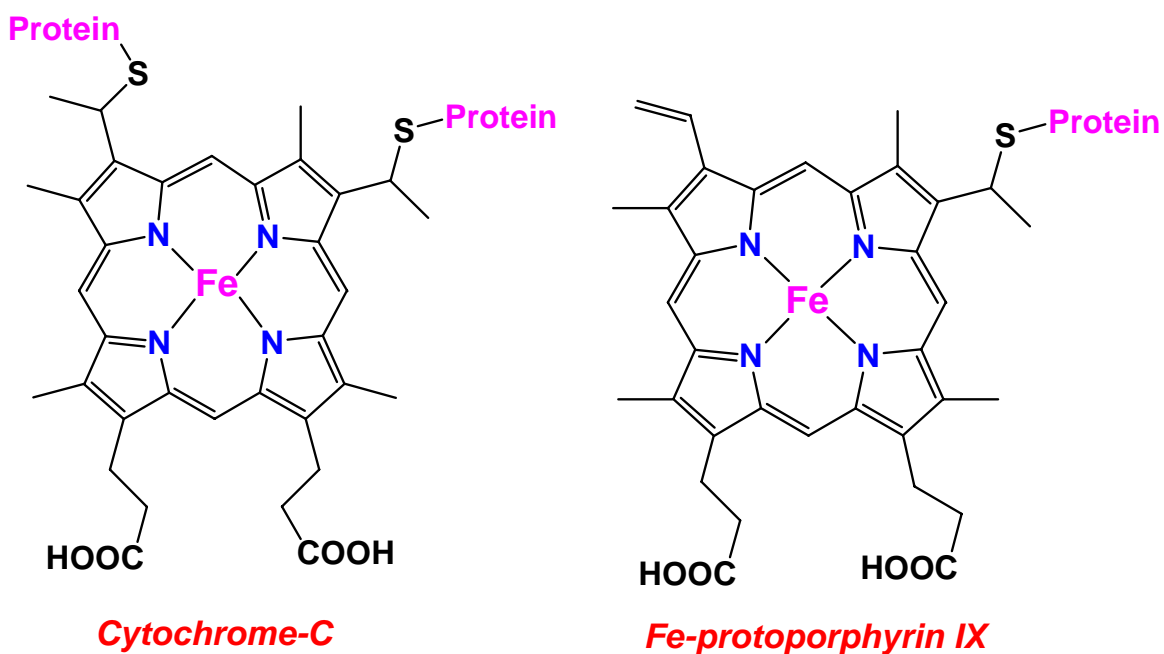

Carbonyl Ligands

empty π^* -acceptor orbitals on carbonyl



powerful π -acceptor ligand!
excellent ligand, therefore, for stabilizing **electron-rich** low-valent metal centers

Standard Bonding Modes:

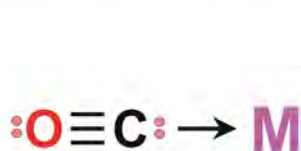

terminal mode
 $2e^-$ neutral donor

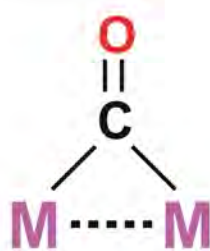

μ_2 -bridging mode
 $2e^-$ neutral donor

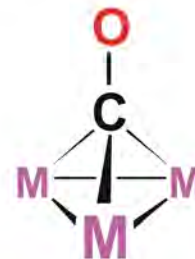

μ_3 -bridging mode
 $3e^-$ neutral donor

Metal carbonyls form one of the oldest (and important) classes of organometallic complexes. Most metal carbonyls are **toxic**!

Examples of **neutral**, **binary** metal carbonyls:

4	5	6	7	8	9	10	11
Ti	$\text{V}(\text{CO})_6$	$\text{Cr}(\text{CO})_6$	$\text{Mn}_2(\text{CO})_{10}$	$\text{Fe}(\text{CO})_5$ $\text{Fe}_2(\text{CO})_9$ $\text{Fe}_3(\text{CO})_{12}$	$\text{Co}_2(\text{CO})_8$ $\text{Co}_4(\text{CO})_{12}$	$\text{Ni}(\text{CO})_4$	Cu
Zr	Nb	$\text{Mo}(\text{CO})_6$	$\text{Tc}_2(\text{CO})_{10}$	$\text{Ru}(\text{CO})_5$ $\text{Ru}_3(\text{CO})_{12}$	$\text{Rh}_4(\text{CO})_{12}$ $\text{Rh}_6(\text{CO})_{16}$	Pd	Ag
Hf	Ta	$\text{W}(\text{CO})_6$	$\text{Re}_2(\text{CO})_{10}$	$\text{Os}(\text{CO})_5$ $\text{Os}_3(\text{CO})_{12}$	$\text{Ir}_4(\text{CO})_{12}$	Pt	Au

Physical Properties of Selected Metal Carbonyls

	Color	mp °C	Sym	IR ν_{CO} cm^{-1}	Misc
$\text{V}(\text{CO})_6$	blue-black	70(d)	O_h	1976	paramagnetic, $S = 1/2$
$\text{Cr}(\text{CO})_6$	white	subl	O_h	2000	Cr-CO = 1.91 Å, air-stable
$\text{Mo}(\text{CO})_6$	white	subl	O_h	2004	Mo-CO = 2.06 Å, air-stable
$\text{W}(\text{CO})_6$	white	subl	O_h	1998	W-CO = 2.06 Å, air-stable in solid state.
$\text{Mn}_2(\text{CO})_{10}$	yellow	154	D_{4d}	2044, 2013, 1983	Mn-Mn = 2.89 Å, bond is easily broken.
$\text{Tc}_2(\text{CO})_{10}$	white	160	D_{4d}	2065, 2017, 1984	Tc-Tc = 3.03 Å
$\text{Re}_2(\text{CO})_{10}$	white	177	D_{4d}	2070, 2014, 1976	Re-Re = 3.04 Å
$\text{Fe}(\text{CO})_5$	yellow	-20	D_{3h}	2034, 2013	bp = 103°C, toxic , Fe-CO (ax) = 1.81 Å, Fe-CO (eq) = 1.83 Å, hv produces $\text{Fe}_2(\text{CO})_9$
$\text{Fe}_2(\text{CO})_9$	gold plates	d	D_{3h}	2082, 2019, 1829	Fe-Fe = 2.46 Å, insoluble in most solvents except for THF where it dissociates to produce $\text{Fe}(\text{CO})_4 + \text{Fe}(\text{CO})_5$
$\text{Fe}_3(\text{CO})_{12}$	green	d	low	complex	
$\text{Ru}(\text{CO})_5$	colorless	-16	D_{3h}	2035, 1999	unstable, forms $\text{Ru}_3(\text{CO})_{12}$
$\text{Ru}_3(\text{CO})_{12}$	orange	150(d)	D_{3h}		
$\text{Os}(\text{CO})_5$	colorless	2	D_{3h}	2034, 1991	v. unstable, forms $\text{Os}_3(\text{CO})_{12}$
$\text{Os}_3(\text{CO})_{12}$	yellow		D_{3h}		
$\text{Co}_2(\text{CO})_8$	orange-red	51(d)	D_{3d}	2107, 2069, 2042, 2031, 2023, 1991	solid state structure has 2 μ -CO's (1886, 1857 cm^{-1}). Solution structure is unbridged. Co-Co = 2.54 Å in solid-state.
$\text{Rh}_4(\text{CO})_{12}$	red		C_{3v}		3 μ -CO's around one triangular Rh_3 face.
$\text{Ni}(\text{CO})_4$	colorless	-25	T_d	2057	bp 34°C, highly toxic , CO's quite labile, Ni-CO = 1.84 Å

Molecular Orbital Diagram for CO:

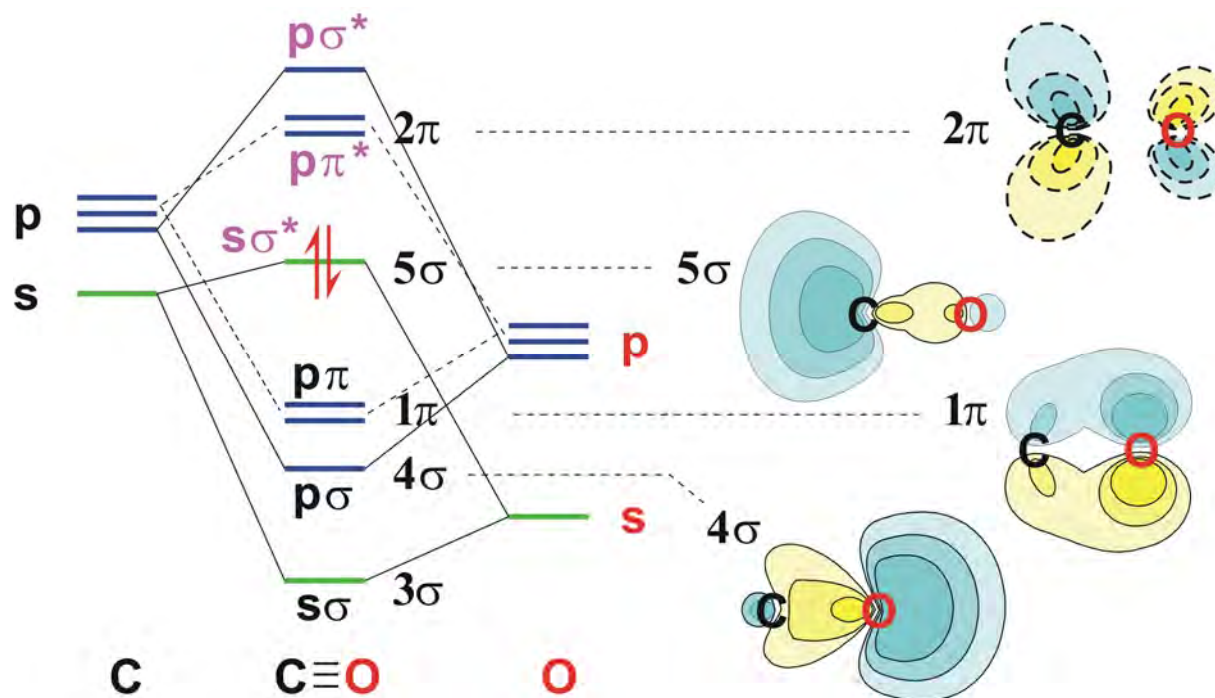

A simple MO diagram for CO is shown above. The highest occupied molecular orbital (HOMO) is indicated by the pair of electrons. This is the 5σ lone pair orbital mainly centered on the carbon and weakly antibonding with respect to the C-O bond (although that isn't too clear from the orbital contour plot). The weak C-O antibonding nature of this MO, however, is clearly seen in the experimental data presented below. The LUMO is strongly π^* antibonding and is low enough in energy to act as a good acceptor orbital for interacting with filled d -orbitals on metals.

Experimental Data Supporting Nature of MO's in CO

Species	Config	C-O Å	ν_{CO} cm^{-1}	Comment
CO	$(5\sigma)^2$	1.13	2143	
CO ⁺	$(5\sigma)^1$	1.11	2184	5σ MO is weakly antibonding
CO*	$(5\sigma)^1(2\pi)^1$	S 1.24	1489	2π MO is strongly antibonding
		T 1.21	1715	

Three types (two of which are important) of CO-Metal bonding interactions:

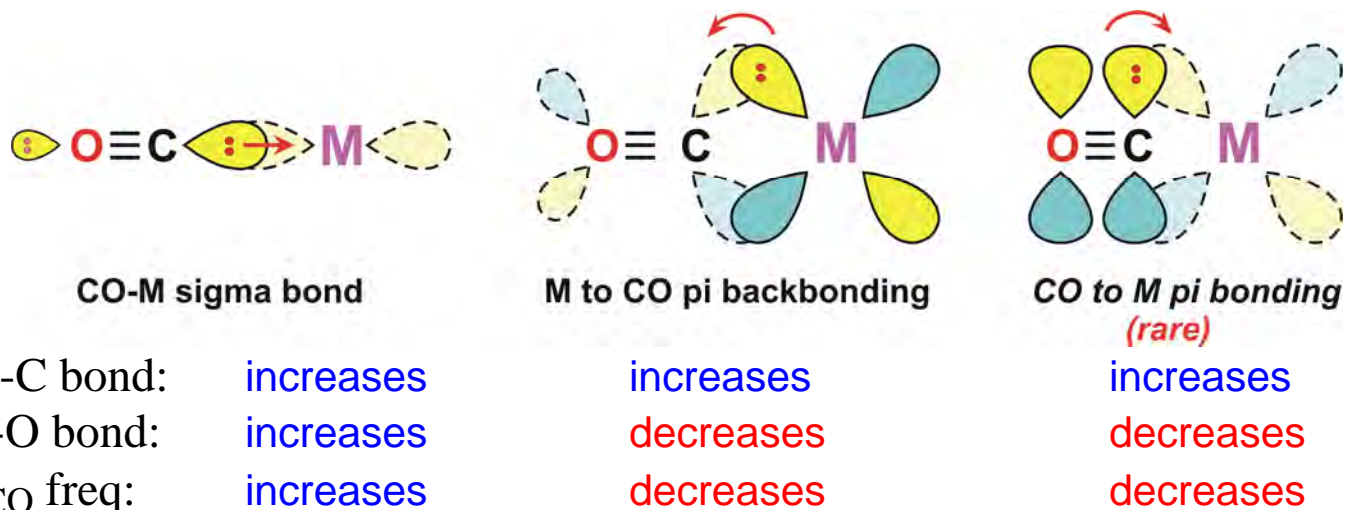

Carbonyl IR Stretching Frequencies

- The **position** of the carbonyl bands in the IR depends mainly on the **bonding mode** of the CO (terminal, bridging) and the **amount of electron density on the metal being π -backbonded to the CO**.
- The **number** (and intensity) of the carbonyl bands one observes depends on the **number of CO ligands present** and the **symmetry** of the metal complex. There are also secondary effects such as Fermi resonance and overtone interactions that can complicate carbonyl IR spectra.

Bonding Modes:

As one goes from a terminal CO-bonding mode to μ_2 -bridging and finally μ_3 -bridging, there is a relatively dramatic drop in the CO stretching frequency seen in the IR.

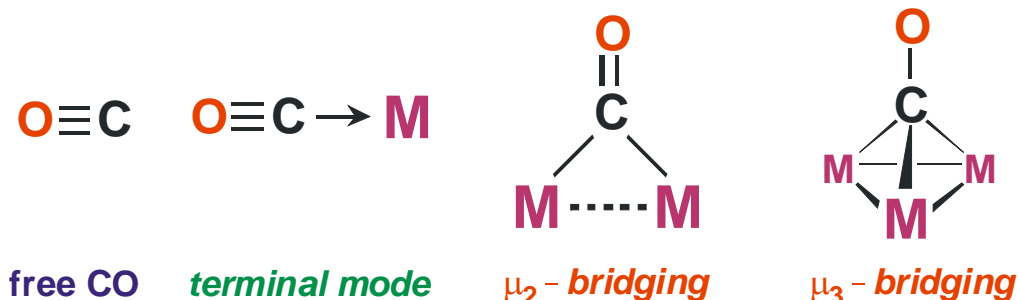

ν_{CO} IR (cm^{-1})	2143	2120 - 1850	1850 - 1720	1730 - 1500
---	------	-------------	-------------	-------------

(for neutral metal complexes)

Note that these ranges are typical for “**neutral**” transition metal complexes with an average amount of electron density on the metal center (see discussion below). Bridging carbonyls tend to have weaker and broader IR bands.

Effect of Electron Density on Metal:

As the electron density on a metal center increases, more π -back-bonding to the CO ligand(s) takes place. This further weakens the C-O bond by pumping more electron density into the formally empty carbonyl π^* orbital. This increases the M-CO bond strength making it more double-bond-like, i.e., the resonance structure **M=C=O** assumes more importance.

This can clearly be seen on the table to the right that illustrates the effect of charge and electronegativity on the amount of metal to CO π -backbonding and the CO IR stretching frequency.

d^x	Complex	ν_{CO} cm^{-1}
	free CO	2143
d^{10}	[Ag(CO)] ⁺	2204
	Ni(CO) ₄	2060
	[Co(CO) ₄] ⁻	1890
	[Fe(CO) ₄] ²⁻	1790
d^6	[Mn(CO) ₆] ⁺	2090
	Cr(CO) ₆	2000
	[V(CO) ₆] ⁻	1860

Shown below is another example of the dramatic effect on the ν_{CO} IR stretching frequencies on reducing $\text{Fe}_2(\mu\text{-PPh}_2)_2(\text{CO})_6$ by 2 electrons to form the dianionic complex $[\text{Fe}_2(\mu\text{-PPh}_2)_2(\text{CO})_6]^{2-}$. The average ν_{CO} frequency shifts almost 150 cm^{-1} to lower energy on reduction.

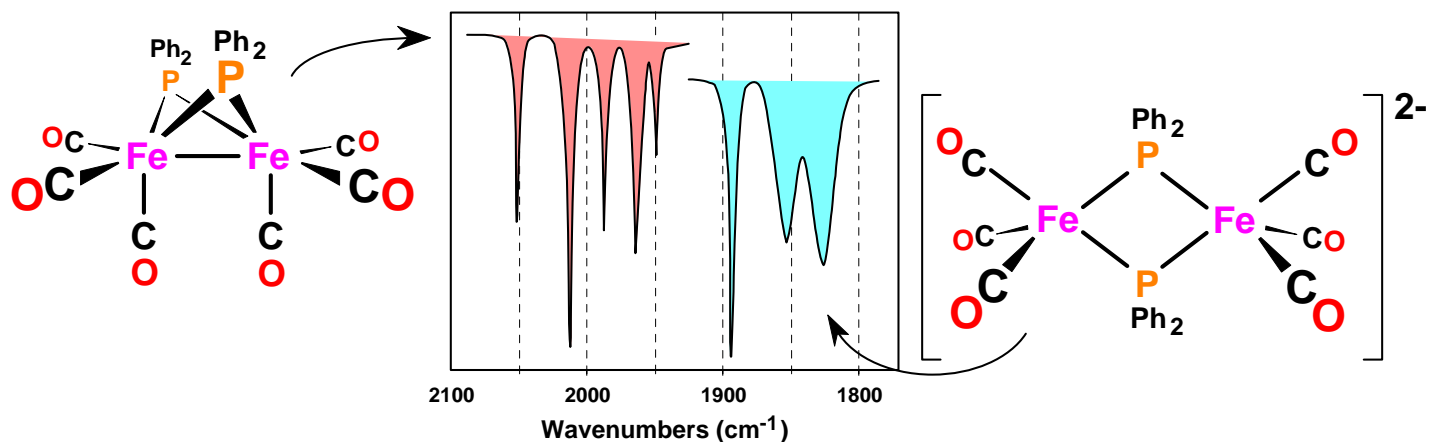

The carbonyl region in the IR spectrum can be very distinctive and useful for help in assigning structures and for indicating the relative amount of electron density present on the metal:

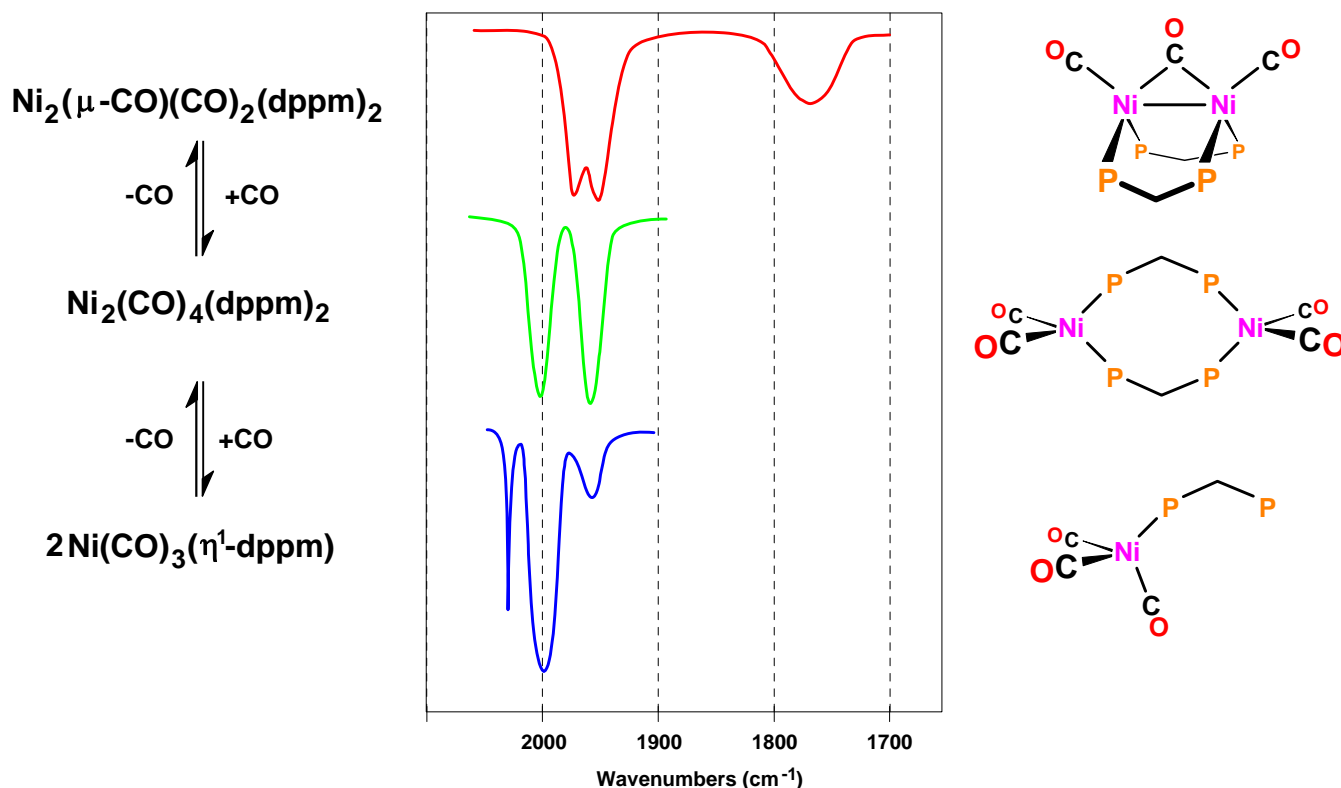

Ligand Donation Effects:

The ability of the ligands on a metal to donate electron density to the metal center certainly has considerable effect on the absolute amount of electron density on that metal. This, in turn, naturally effects the ν_{CO} IR stretching frequencies in metal carbonyl complexes. Ligands that are *trans* to a carbonyl can have a particularly large effect on the ability of the CO ligand to effectively π -backbond to the metal. For example 2 *trans* π -backbonding ligands will partially compete for the same *d*-orbital electron density, weakening each others net M-L π -backbonding.

Complex	$\nu_{\text{CO}} \text{ cm}^{-1}$
$\text{Mo}(\text{CO})_3(\text{PF}_3)_3$	2090, 2055
$\text{Mo}(\text{CO})_3(\text{PCl}_3)_3$	2040, 1991
$\text{Mo}(\text{CO})_3[\text{P}(\text{OMe})_3]_3$	1977, 1888
$\text{Mo}(\text{CO})_3(\text{PPh}_3)_3$	1934, 1835
$\text{Mo}(\text{CO})_3(\text{NCCH}_3)_3$	1915, 1783
$\text{Mo}(\text{CO})_3(\text{triamine})_3$	1898, 1758
$\text{Mo}(\text{CO})_3(\text{pyridine})_3$	1888, 1746

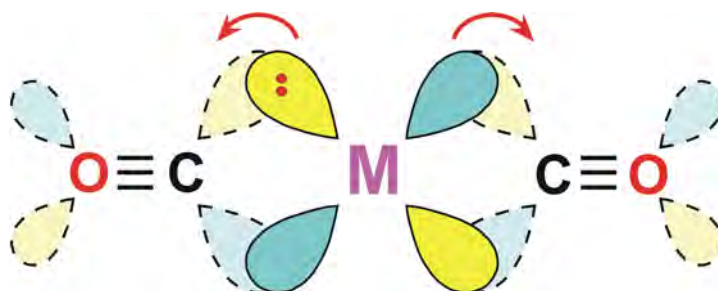

When the *trans* ligand is a σ -donating ligand, this can increase the M-CO bond strength (more M=C=O character) by allowing unimpeded metal to CO π -backbonding. Pyridine and amines are not that strong σ -donors, but they are even worse π -backbonding ligands. So the CO has virtually no competition for π -backdonation.

Based on CO IR stretching frequencies, the following ligands can be ranked from **best** π -acceptor to **worst**:

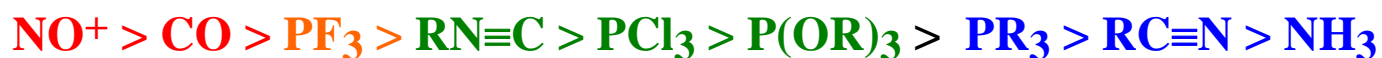

Semi-Bridging Carbonyls:

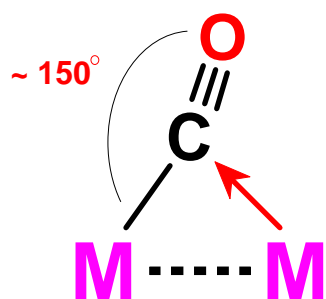

Unsymmetrical bridging form. π^* system accepts electron density from second metal center. Usually accompanied by distortions away from a linear M-CO (180°) or a symmetrically bridging CO (120°). Typical M-CO angle around 150° (but with considerable variations).

Example: Substituting 2 carbonyls in $\text{Fe}_2(\mu\text{-CO})_3(\text{CO})_6$ with a **bipy** ligand leads to a considerable change in the structure, particularly in the bridging CO region. The better σ -donating **bipy** ligand increases the e^- density on that Fe atom. This generates an **asymmetrically charged** complex. The higher partial negative charge on the **bipy**-substituted Fe center can be reduced by dumping some of it specifically into the π^* orbital of one of the bridging carbonyls, turning it into a semi-bridging CO.

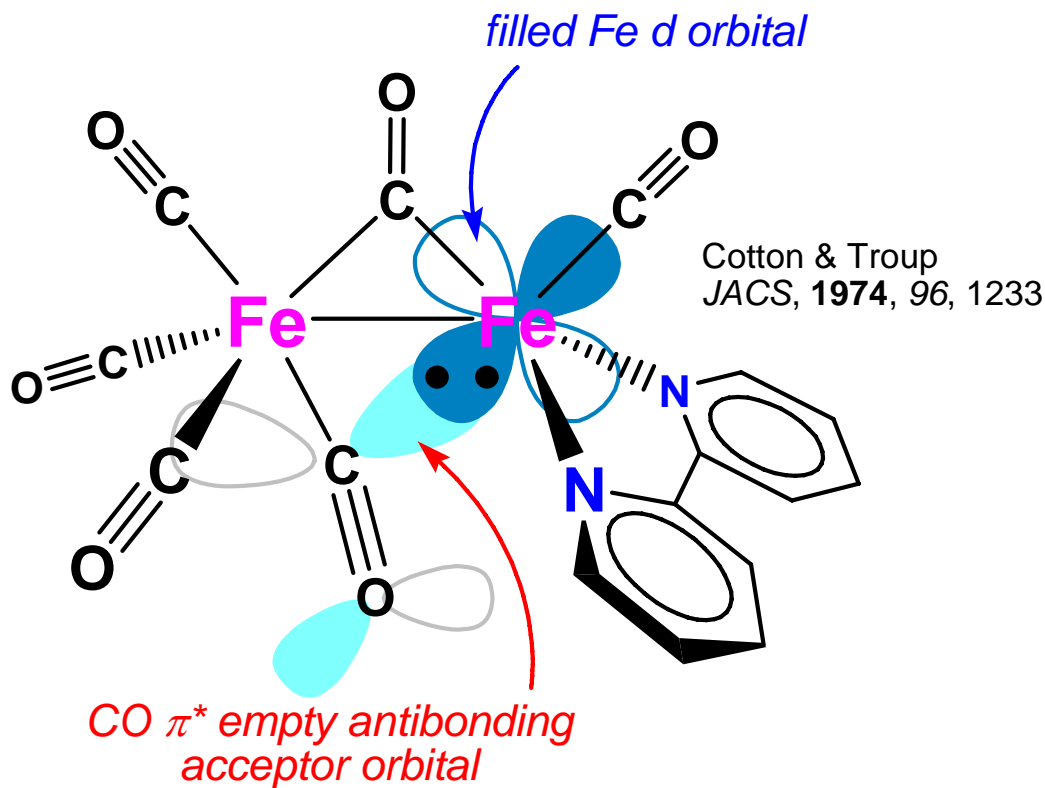

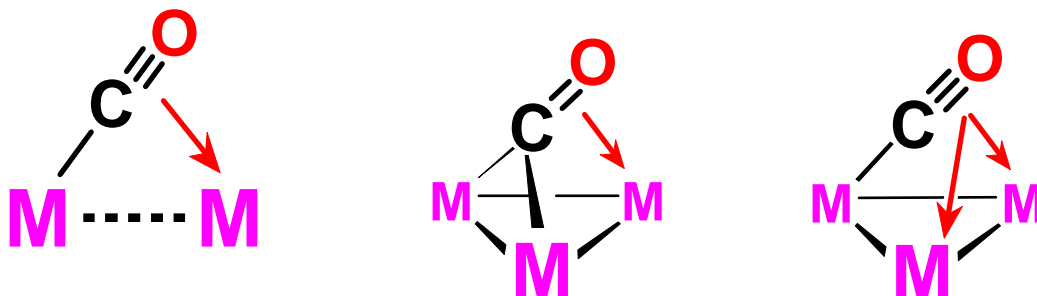
σ/π Bridging CO:

This is where the CO not only acts as a traditional σ -donor/ π -acceptor to one or more metal centers, but also as a π -donor to additional metals. This will occur for more electron deficient metal complexes where the metal centers have less need to π -backbond to the carbonyl, but have the empty orbitals to accept electron density from the carbonyl π -system. The CO ligand here can act as a **4 or 6 electron donor!**

Problem: Consider the example below, do you think that the bridging CO should act more as a π -donor or π -acceptor?

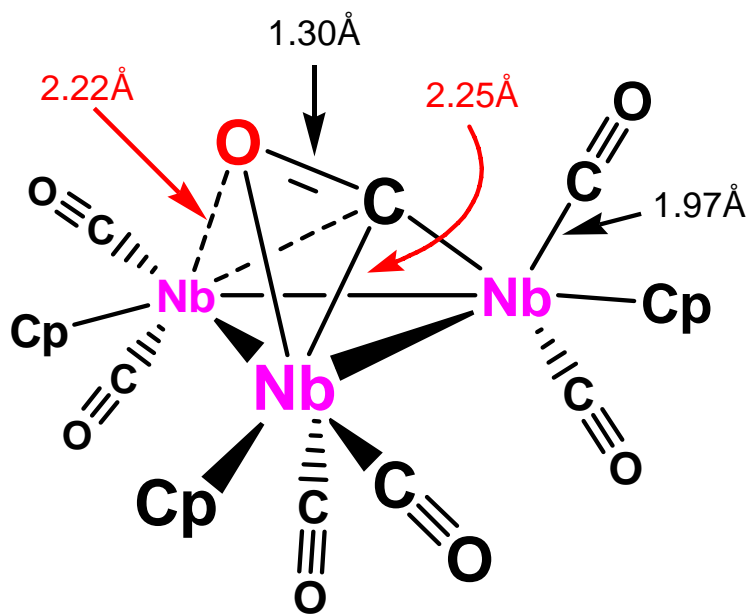
CO acting as π -donor or π -acceptor?

Herrman & coworkers
JACS, 1981, 103, 1692

Problem: Which of the following metal carbonyl IR spectra represents the compound with the least amount of electron density on the metal center? Briefly discuss the reasoning for your choice. Which compound will lose CO the easiest?

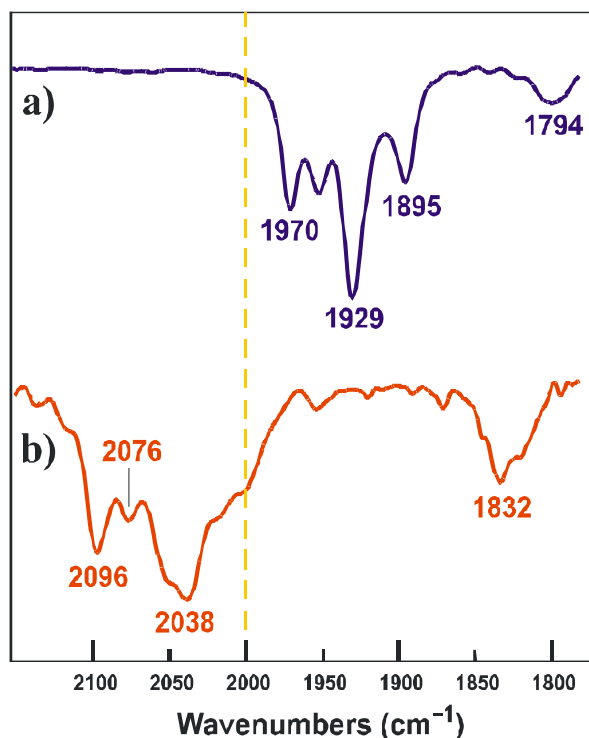

Problem: Which of the following metal carbonyl compounds will have the highest ν_{CO} stretching frequency in the IR? Why? Will this be the most electron-rich or deficient compound?

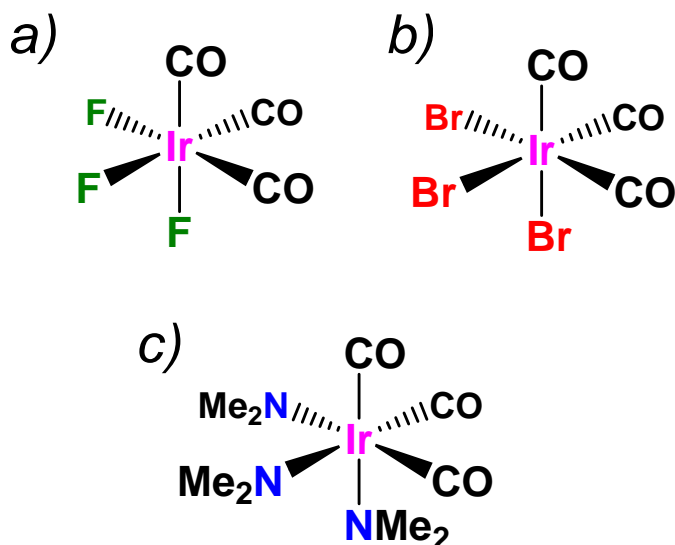

Phosphine Donors

empty d orbitals on phosphine can act as π -acceptor orbitals } not very important unless R-groups are electron-withdrawing

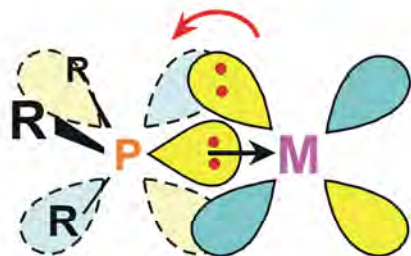

Phosphine ligands

*excellent soft-donor ligands
with a wide variety of easily adjusted
steric and electronic factors*

neutral $2e^-$ donor

R = carbon groups { phosphine (US)
phosphane (Germany/Europe)

R = OR groups \longrightarrow phosphite

Because of the three R-groups on the phosphine ligand and the overall tetrahedral coordination geometry it is the most versatile of the neutral 2-electron donor ligands. Variation of the three R-groups can effect:

- large changes in the donor/acceptor properties of the phosphine (from excellent donor/poor π -acceptor to poor donor/excellent π -acceptor)
- large changes in the steric profile of the phosphine (from fairly small to enormous)
- generation of a large number of polydentate polyphosphines (bis-, tris-, tetra-, penta-, and hexaphosphine ligands are all known) that can adopt specific coordination geometries (cis-enforcing, facial tridentate, bridging, bridging and chelating, etc.)

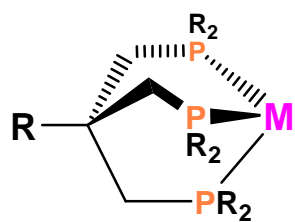

$M(\eta^3\text{-tripod})$
facial coordinating

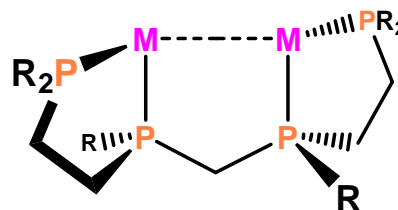

racemic- $M_2(P_4)$
binucleating phosphine
able to bridge and chelate 2 metals

Tolman's Cone Angle and Electronic Parameter

In 1977 Chad Tolman (Dupont Chemicals) published a classic review article covering methods that he developed for ordering a wide variety of phosphine ligands in terms of their electron-donating ability and steric bulk (*Chemical Reviews*, **1977**, vol 77, pages 313-348).

The **electron-donating ability** of a phosphine ligand was determined by reacting one equivalent of the phosphine (monodentate only) with $\text{Ni}(\text{CO})_4$ to make a $\text{Ni}(\text{CO})_3(\text{phosphine})$ complex. He then measured the carbonyl ν_{CO} IR stretching frequency (the very sharp a_1 high energy mode) of the $\text{Ni}(\text{CO})_3(\text{phosphine})$ complex. The more electron density the phosphine ligand donated to the metal center, the more π -back-bonding occurred to the carbonyl ligands, weakening the $\text{C}\equiv\text{O}$ triple bond, thus lowering the ν_{CO} IR stretching frequency.

Lowest CO stretching frequency:

most donating phosphine

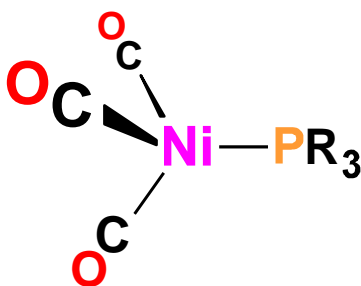

Highest CO stretching frequency:

least donating phosphine (best π -acceptor)

The **size** or **steric bulk** of a phosphine ligand was determined from simple 3-D space-filling models of the phosphine ligands. Tolman coined the name **cone angle** (θ) to indicate the approximate amount of “space” that the ligand consumed about the metal center.

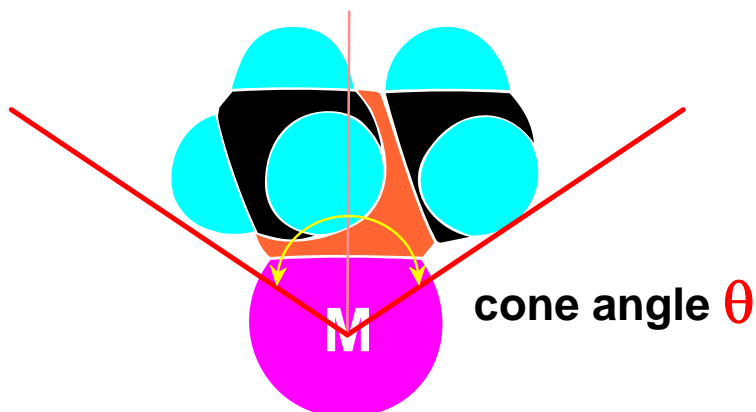

Phosphine Donor Ability Ranked by Tolman's Electronic Parameter ν (most donating to least)

PR_3	mixed	$P(OR)_3$	PX_3	ν, cm^{-1}
$P(t\text{-Bu})_3$				2056.1
PCy_3				2056.4
$P(o\text{-OMe-C}_6\text{H}_4)_3$				2058.3
$P(i\text{-Pr})_3$				2059.2
PBu_3				2060.3
PEt_3				2061.7
	PEt_2Ph			2063.7
PMe_3				2064.1
	PMe_2Ph			2065.3
$P(p\text{-OMe-C}_6\text{H}_4)_3$	$PPh_2(o\text{-OMe-C}_6\text{H}_4)$			2066.1
PBz_3				2066.4
$P(o\text{-Tol})_3$				2066.6
$P(p\text{-Tol})_3$	$PEtPh_2$			2066.7
	$PMePh_2$			2067.0
$P(m\text{-Tol})_3$				2067.2
	$PPh_2(NMe_2)$			2067.3
	$PPh_2(2,4,6\text{-Me-C}_6\text{H}_2)$			2067.4
	$PPhBz_2$			2067.6
	$PPh_2(p\text{-OMe-C}_6\text{H}_4)$			2068.2
	PPh_2Bz			2068.4
PPh_3				2068.9
	$PPh_2(CH=CH_2)$			2069.3
$P(CH=CH_2)_3$	$PPh_2(p\text{-F-C}_6\text{H}_4)$			2069.5
	$PPh(p\text{-F-C}_6\text{H}_4)_2$			2070.0
$P(p\text{-F-C}_6\text{H}_4)_3$				2071.3
	$PPh_2(OEt)$			2071.6
	$PPh_2(OMe)$			2072.0
	$PPh(O\text{-}i\text{-Pr})_2$			2072.2

Phosphines 4

$P(p\text{-Cl-C}_6\text{H}_4)_3$			2072.8
	PPh_2H		2073.3
	$PPh(OBu)_2$		2073.4
$P(m\text{-F-C}_6\text{H}_4)_3$			2074.1
	$PPh(OEt)_2$		2074.2
	$PPh_2(OPh)$		2074.6
	$PPh_2(C_6F_5)$		2074.8
		$P(O\text{-}i\text{-Pr})_3$	2075.9
		$P(OEt)_3$	2076.3
	$PPhH_2$		2077.0
$P(CH_2CH_2CN)_3$			2077.9
		$P(OCH_2CH_2OMe)_3$	2079.3
		$P(OMe)_3$	2079.5
	$PPh(OPh)_2$		2079.8
		PPh_2Cl	2080.7
		PMe_2CF_3	2080.9
		$P(O\text{-}2,4\text{-Me-C}_6\text{H}_3)_3$	PH_3 2083.2
		$P(OCH_2CH_2Cl)_3$	2084.0
		$P(O\text{-Tol})_3$	2084.1
		$P(OPh)_3$	2085.3
		$P(OCH_2)_3CR$	2086.8
		$P(OCH_2CH_2CN)_3$	2087.6
	$P(C_6F_5)_3$		2090.9
		PCl_3	2097.0
		PF_3	2110.8

**Phosphine Steric Bulk Ranked by
Tolman's Cone Angle θ (smallest to largest)**

PR_3	mixed	$P(OR)_3$	PX_3	θ ($^\circ$)
			PH_3	87
	$PPhH_2$	$P(OCH_2)_3CR$		101
			PF_3	104
	$Me_2PCH_2CH_2PMe_2$	$P(OMe)_3$		107
		$P(OEt)_3$		109
	$P(CH_2O)_3CR$			114
	$Et_2PCH_2CH_2PEt_2$			115
	$P(OMe)_2Ph$ or Et			115
	$PPh(OEt)_2$			116
PMe_3				118
	$Ph_2PCH_2PPh_2$			121
	PMe_2Ph			122
		PMe_2CF_3	PCl_3	124
	$Ph_2PCH_2CH_2PPh_2$			125
	PPh_2H	$P(OPh)_3$		128
		$P(O-i-Pr)_3$		130
			PBr_3	131
PEt_3, PPr_3, PBu_3	$PPh_2(OMe)$			132
	$PPh_2(OEt)$			133
	$PEt_2Ph, PMePh_2$			136
$P(CF_3)_3$				137
	$PEtPh_2$			140
	$Cy_2PCH_2CH_2PCy_2$			142
PPh_3				145
	$PPh_2(i-Pr)$			150

	PPh ₂ (<i>t</i> -Bu)	157
	PPh ₂ (C ₆ F ₅)	158
P(<i>i</i> -Pr) ₃		160
PBz ₃		165
PCy ₃	PPh(<i>t</i> -Bu) ₂	170
	P(O- <i>t</i> -Bu) ₃	175
P(<i>t</i> -Bu) ₃		182
	P(C ₆ F ₅) ₃	184
P(<i>o</i> -Tol) ₃		194
P(mesityl) ₃		212

Commonly Used Monodentate Phosphines:

PPh₃ (145°, medium donor), triphenylphosphine, tpp “The KING”

- air-stable, white crystalline material, no odor to speak of

Increasing σ-Donor Ability:

PMePh₂ (136°), PMe₂Ph (122°), PMe₃ (118°), PEt₃ (132°)

P(Cy)₃ (170°) tricyclohexylphosphine, P(*t*-Bu)₃ (182°)

- the alkyl phosphines are strong σ-donors; usually colorless liquids, somewhat to very air-sensitive, horrible smelling (unless very high MW and non-volatile)

Poor σ -Donors, Good π -Acceptors:

Phosphites: P(OMe)_3 (107°), P(OEt)_3 (110°), P(OPh)_3 (128°)

- phosphites are relatively poor σ -donors, but can be fairly good π -acceptor ligands (about half as good as CO); low MW ones are usually colorless liquids, higher MW compounds are white solids; usually air-stable but moisture sensitive; sometimes sweet smelling

PF_3 (104°) } strong π -acceptor, almost as good as CO

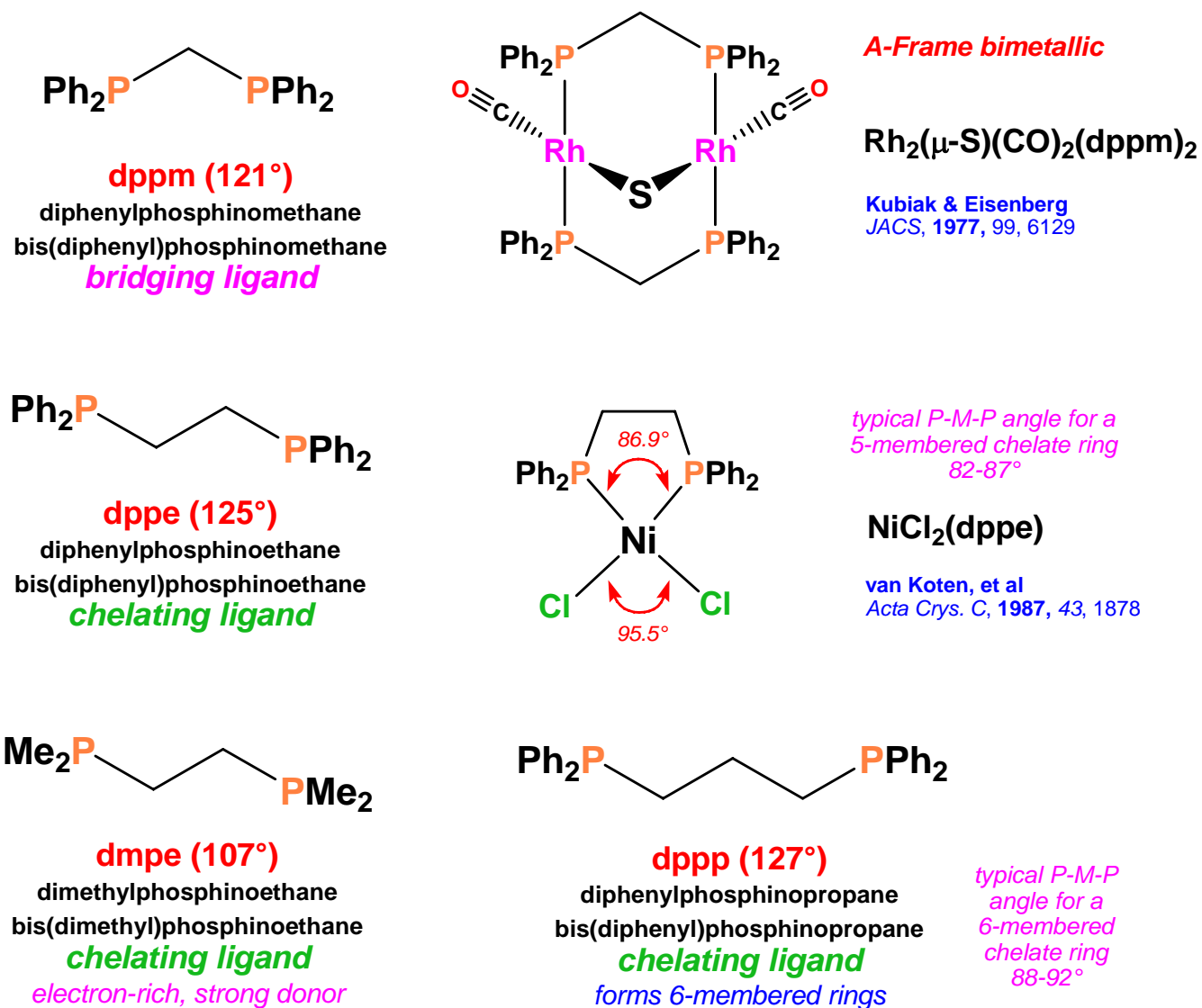
Commonly Used Polydentate Phosphines:

facial coordinating mode

Vaira & coworkers
Angew. Chem. Int. Ed., 1987, 26, 916

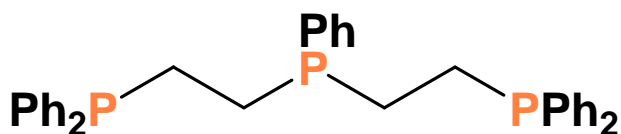

triphos

bis(diphenylphosphinoethyl)phenylphosphine
bis-chelating ligand

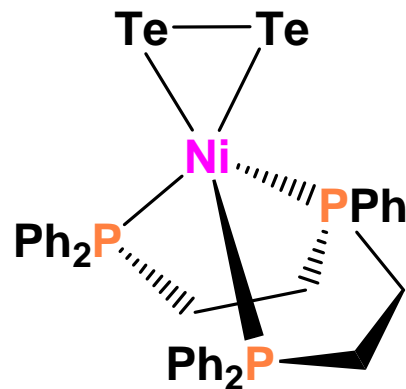

Bertinsson
Acta Cryst. C., 1983, 39, 563

planar coordinating mode

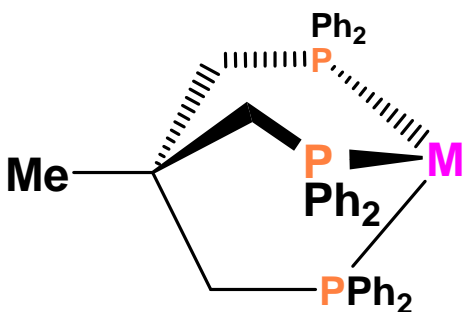
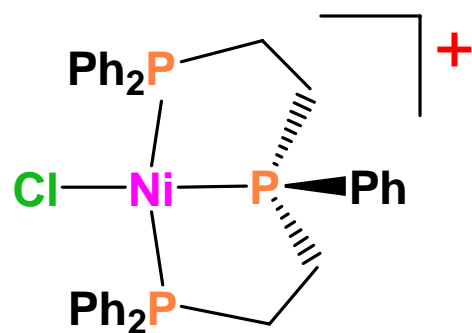

tripod

tris(diphenylphosphinoethyl)methane
bis-chelating ligand
facial coordination

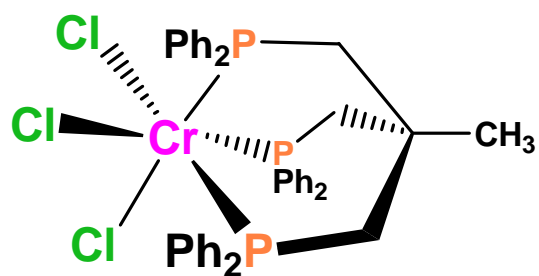

Jones & coworkers
Inorg. Chem., 1986, 25, 1080

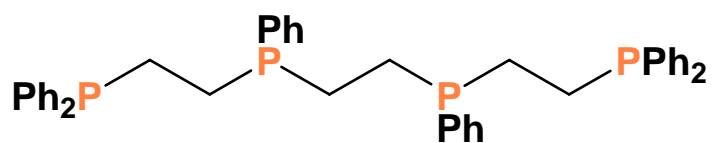
**tetraphos-1**

1,1,4,7,10,10-hexaphenyl-1,4,7,10-tetraphosphadecane
tris-chelating or binucleating (bridging) ligand

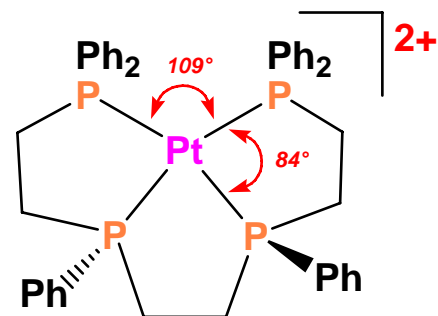

Bruggeller & coworkers
Acta Cryst. C., 1990, 46, 388

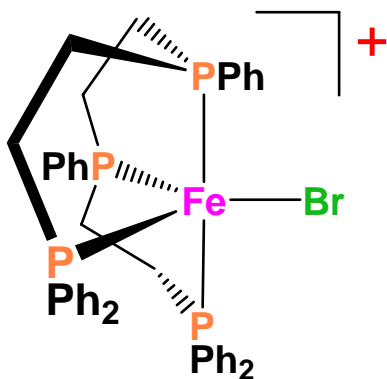

Bacci & coworkers
Inorg. Chem., 1984, 23, 2798

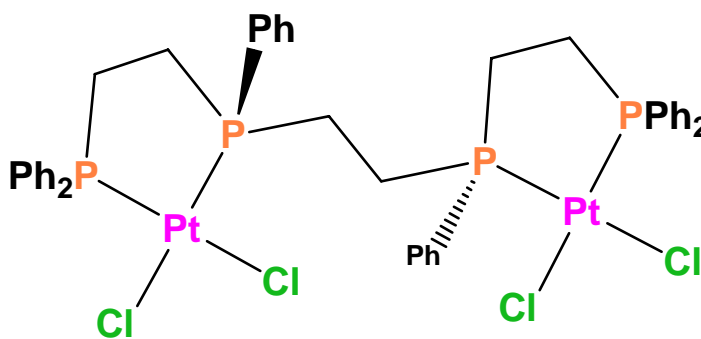

Bruggeller & coworkers
Inorg. Chim. Acta, 1992, 197, 75

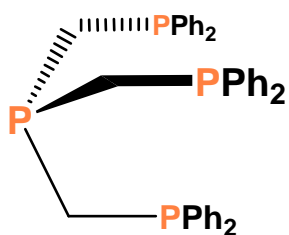
**tetraphos-2**

tris(diphenylphosphinoethyl)phosphine
tris-chelating ligand
facial coordination

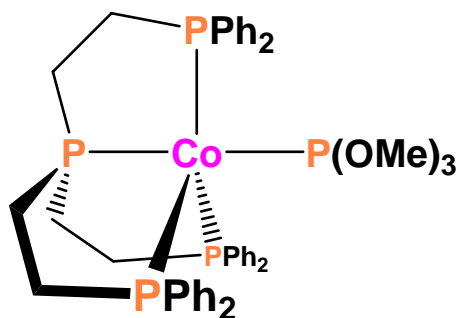

Meek & coworkers
Inorg. Chem., 1983, 25, 616

Polyphosphine review: Cotton & Hong, *Progress in Inorg. Chem.*, 1992, 40, 179-289.

Some Structural Issues

Phosphines have only been characterized as simple 2 e⁻ donating, terminal-only ligands. No true μ_x -bridging monophosphines are known (although bridging *phosphides* are very common).

Phosphines generally tend to orient *trans* to one another in order to minimize steric interactions (especially true for bulky PR₃). Chelating bisphosphine ligands are used to enforce *cisoidal* coordination geometries when needed.

Some typical first row M-PR₃ average bond distances:

Ti-P	2.6 Å
V-P	2.5 Å
Cr-P	2.4 Å
Ni-P	2.1 Å

M-P distances decrease due to the contraction of the metal atom radius as one proceeds to the right and the atoms become more electronegative. Distances also decrease due to stronger M-P bonding as one moves to the right across the transition metal series (late transition metals are softer and prefer bonding to phosphines).

M-P bonds are the strongest for alkylated phosphine ligands bonding to a neutral or monocationic middle to later transition metal center that is electron-deficient. High oxidation state early transition metals are too “hard” to have very effective bonding to most phosphines, although more and more early transition metal phosphine complexes are being characterized and found to be reasonably stable.

Metal centers that are *too* electron-rich also will not want to have a strong electron-donating alkylated phosphine coordinated, this leads to weaker M-P bonding and phosphine dissociation. One example is $\text{Rh}_2(\mu\text{-CO})(\text{CO})_4(\text{P}_4)$, shown below, that rearranges to form the asymmetric $\mu, \eta^3, \eta^1\text{-P}_4$ coordinated dimer, shown to the right, when one CO ligand is lost:

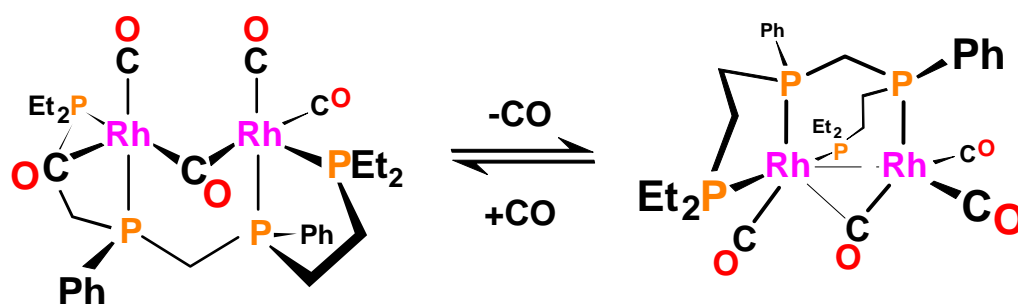

This is a fully reversible CO and temperature dependent equilibrium. The asymmetric dimer, which has been structurally characterized, can be considered to be zwitterionic: one $\text{Rh}(+)$ center that has 3 phosphines coordinated and a $\text{Rh}(-1)$ pseudo-tetrahedral center that has 3 π -accepting CO ligands. One of these CO's is acting as a semi-bridging ligand π -donating some electron density to the other formally cationic square-planar rhodium.

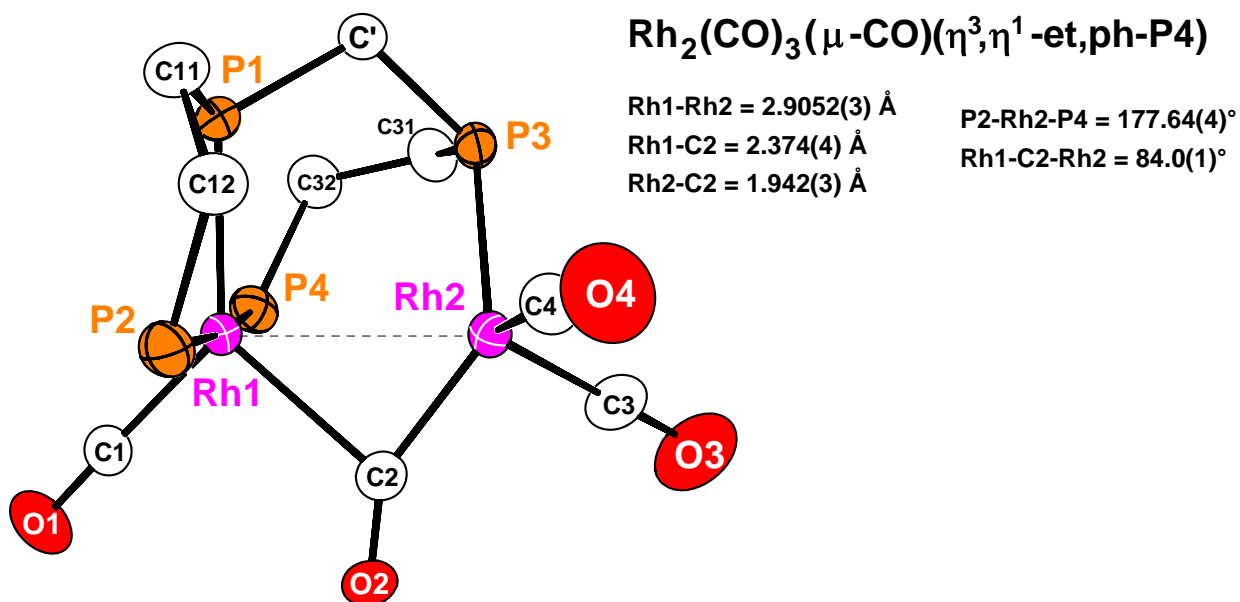

Problem: For each of the following pairs of metal complexes, which should have the highest average carbonyl IR stretching frequency.

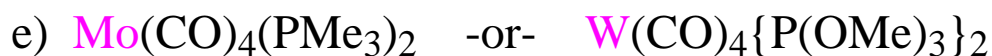
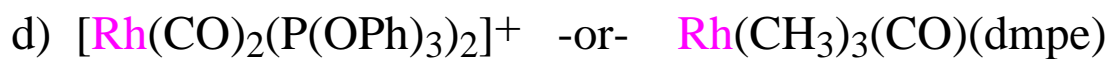
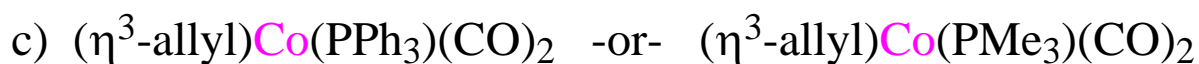
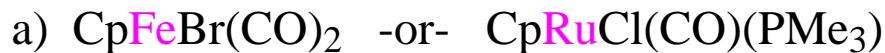

^{31}P NMR Spectroscopy

The ^{31}P (P-31) nucleus has a nuclear spin of $1/2$ and is 100% abundant! This makes it functionally equivalent to the ^1H nucleus: therefore, ^{31}P NMR is an extremely valuable tool in studying phosphines in general, and M-PR_3 complexes in particular. This is another reason why phosphines are such valuable ligands.

The typical chemical shift region for ^1H NMR spans about 20 ppm. The ^{31}P NMR chemical shift region, however, is much larger and can span almost 1000 ppm (including *phosphide* ligands)! Chemical shifts for some phosphines are listed below:

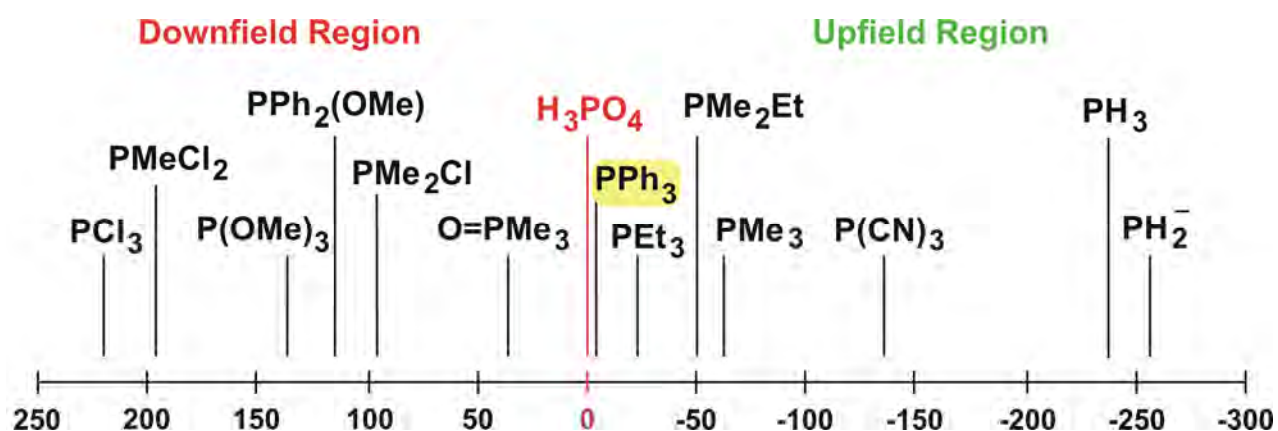

Ligand	Chemical Shift (ppm)	Ligand	Chemical Shift (ppm)
PCl_3	220	H_3PO_4	0 (reference)
PMeCl_2	191	$\text{P}(\text{CF}_3)_3$	-2
$\text{PCy}(\text{OBu})_2$	184	PPh_3	-6
$\text{P}(\text{OMe})_3$	140	PEt_3	-20
$\text{P}(\text{OPh})_3$	126	NaPPh_2	-24
PEt_2Cl	119	PMePh_2	-28
$\text{PPh}_2(\text{OMe})$	115	PPr_3	-33
PF_3	97	PMe_2Et	-50
PMe_2Cl	96	PMe_3	-62
$\text{PMe}_2(\text{O-}t\text{-Bu})$	91	$\text{P}(\text{CN})_3$	-135
$\text{O}=\text{P}(\text{CH}_2\text{OH})_3$	45	PH_3	-238
$\text{O}=\text{PMe}_3$	36	KPH_2	-255

It is important to note that the positive and negative convention for chemical shifts for ^{31}P NMR compounds changed in the early 1970's. In these older references, free PMe_3 would be listed with a +62 ppm chemical shift.

Chelate Ring Effects:

The presence of chelate rings can have a significant effect on the ^{31}P NMR chemical shift position of M-P complexes (Cf., Garrou, *Chem. Rev.*, **1981**, 81, 229):

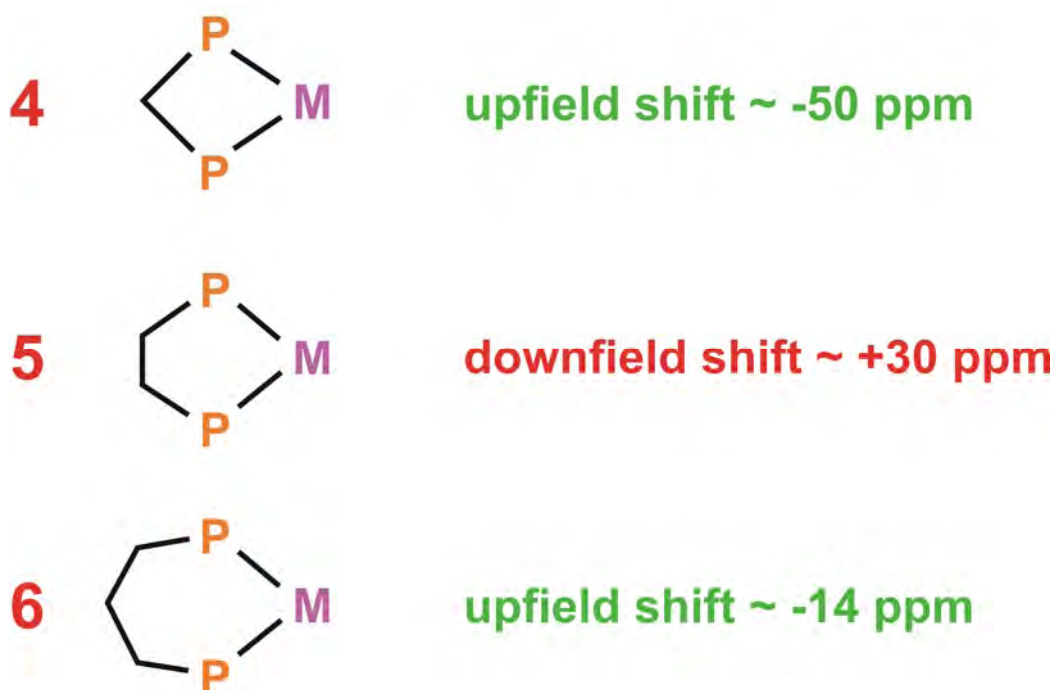

Similarly, the metal center can also have a considerable shifting effect. Consider the following dppm chelates with 4-member rings:

$\text{W}(\text{CO})_4(\eta^2\text{-dppm})$	-23.7 ppm
$\text{Mo}(\text{CO})_4(\eta^2\text{-dppm})$	0 ppm
$\text{Cr}(\text{CO})_4(\eta^2\text{-dppm})$	23.5 ppm

^{31}P NMR, as with ^1H and ^{13}C methods, can be exceptionally useful in characterizing metal-phosphine complexes and structures:

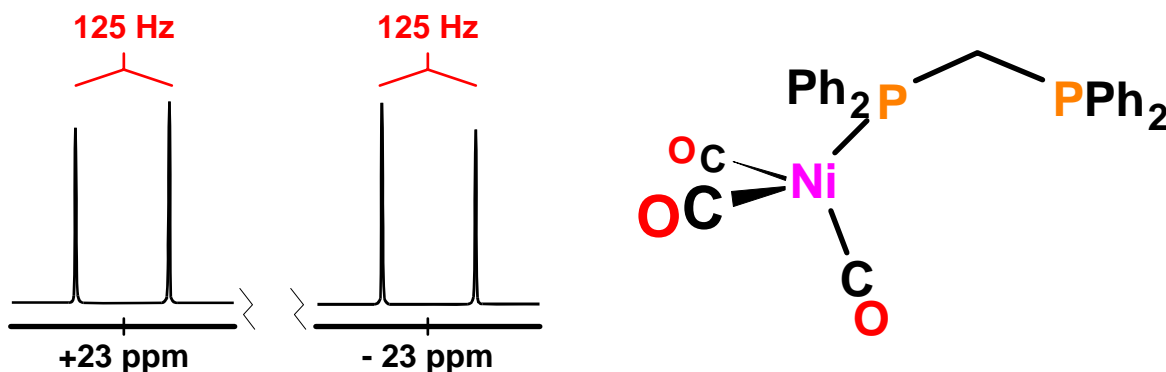

Problem: Which of the following complexes will have the *highest* ν_{CO} stretching frequency in the IR? Why?

- A) $[\text{Mn}(\text{CO})_3\{\text{P}(\text{OPh})_3\}_3]^+$
- B) $\text{W}(\text{CO})_3(\text{PEt}_3)_3$
- C) $[(\text{PF}_3)\text{Ag}(\text{CO})]^+$

Problem: Which of the following complexes will have the *lowest* ν_{CO} stretching frequency in the IR? Why?

- A) $\text{Ni}(\text{CO})(\text{PMe}_3)_3$
- B) $\text{Fe}(\text{CO})_4(\text{PPh}_3)$
- C) $[\text{Re}(\text{CO})_2\{\text{P}(\text{OMe})_3\}_4]^+$

Hydride Ligands

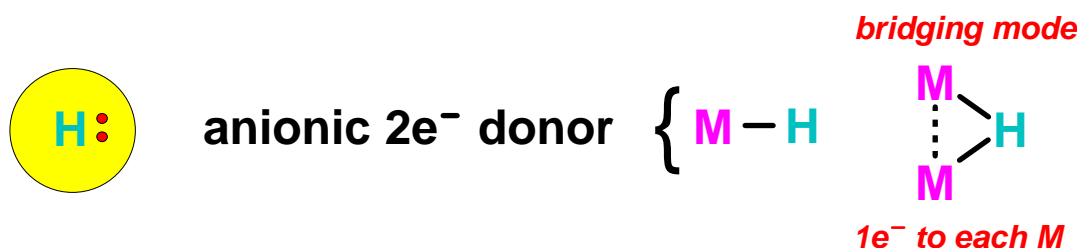

Hydride nomenclature comes from the NMR behavior:

$M-H \sim -5 \text{ to } -25 \text{ ppm}$ *for d^1* *d^9 metals!!*
upfield shift indicates “hydridic” chemical nature

$HCo(CO)_4$ $^1H \text{ NMR} = -10.7 \text{ ppm}$

BUT: $HCo(CO)_4$ $H^+ + Co(CO)_4^-$
strong acid in H_2O , $MeOH$
similar to HCl !!

d^0 $Cp^*_2ZrH_2$ $\delta = +7.5 \text{ ppm}$
 d^{10} $[HCu\{P(p\text{-tolyl})_3\}]_6$ $\delta = +3.5 \text{ ppm}$

The presence of partially filled d orbitals on the transition metal has a considerable shielding effect (moves the chemical shift of the NMR resonance to more negative ppm) on the hydride 1H NMR chemical shift position.

IR Spectra: $M-H$ $2200 - 1600 \text{ cm}^{-1}$ } can be very weak or absent
 $M_2(\mu-H)$ $1600 - 800 \text{ cm}^{-1}$ } broader (weak or absent)

Late Transition Metals: tend to be more “protic”
 Early Transition Metals: tend to be more “hydridic”

pK_a Values for Transition Metal Hydrides in Various Solvents

Metal Hydride Complex	Solvent		
	H ₂ O	MeOH	CH ₃ CN
HV(CO) ₆	strong acid		
HV(CO) ₅ (PPh ₃)	6.8		
CpCrH(CO) ₃		5.4	13.3
CpMoH(CO) ₃		6.2	13.9
Cp*MoH(CO) ₃			17.1
CpWH(CO) ₃		8.0	16.1
CpWH(CO) ₂ (PMe ₃)			26.6
HMn(CO) ₅			15.1
HRe(CO) ₅			~21
H ₂ Fe(CO) ₄	4.0		11.4
H ₂ Ru(CO) ₄			18.7
H ₂ Os(CO) ₄		15.2	20.8
CpFeH(CO) ₂			19.4
Cp*FeH(CO) ₂			26.3
CpRuH(CO) ₂			20.2
HCo(CO) ₄	strong acid	strong acid	8.4
HCo(CO) ₃ {P(OPh) ₃ }	5.0		11.4
HCo(CO) ₃ (PPh ₃)	7.0		15.4
HNi[P(OMe) ₃] ₄ ⁺		1.5	12.3
HPd[P(OMe) ₃] ₄ ⁺		1.0	8.0
HPt[P(OMe) ₃] ₄ ⁺		10.2	18.5
H ₄ Ru ₄ (CO) ₁₂		11.7	
H ₄ Os ₄ (CO) ₁₂		12.3	
H ₂ Ru ₄ (CO) ₁₃		11.1	

Problem: Which of the following pairs of metal hydrides is the most acidic (lowest pK_a)?

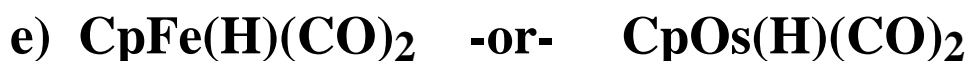
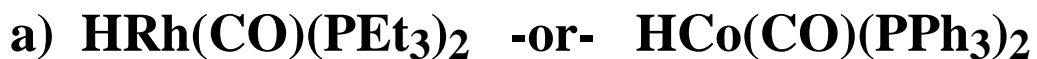

Structural Features:

Hydride is the smallest ligand and as a result, M-H distances are typically quite short: 1.8 to about 1.5 Å, depending on the metal. Periodic trends are followed, as noted for phosphine-metal distances. Hydrides can be quite difficult to observe via X-ray diffraction (the most common technique used to determine structures) due to the very small number of electrons on the hydride vs. adjacent atoms, especially the metal. Therefore, neutron diffraction studies are considered best for accurately locating and identifying hydrides on metal centers.

Synthesis: For moderately electron-rich metals with 2 or more d electrons, the **oxidative addition** of molecular H₂ to the metal center is quite common and very important for catalysis:

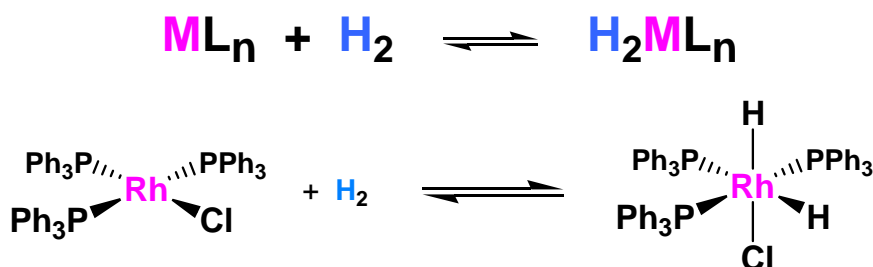

Occasionally, if the metal center has the right amount of electron density (not too much, not too little) molecular H₂ complexes can form:

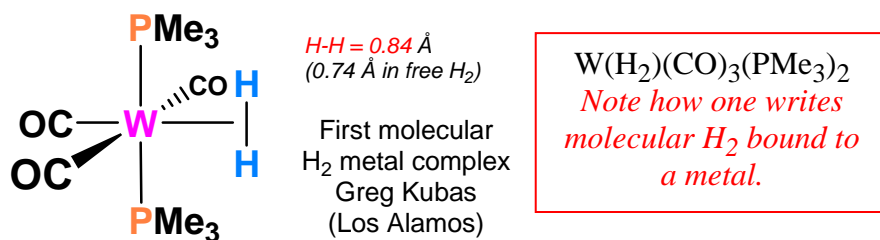

Hydrides can also be formed from the **oxidative addition** of “active” hydrogen sources such as silanes (HSiR₃) or acids:

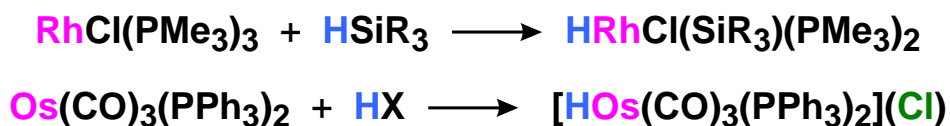

Naturally, hydride sources like LiAlH₄, borohydrides, or even NaH can be used to substitute off more weakly coordinated ligands like halides.

Alkyl, Aryl, Carbene, Alkylidene & Carbyne Ligands

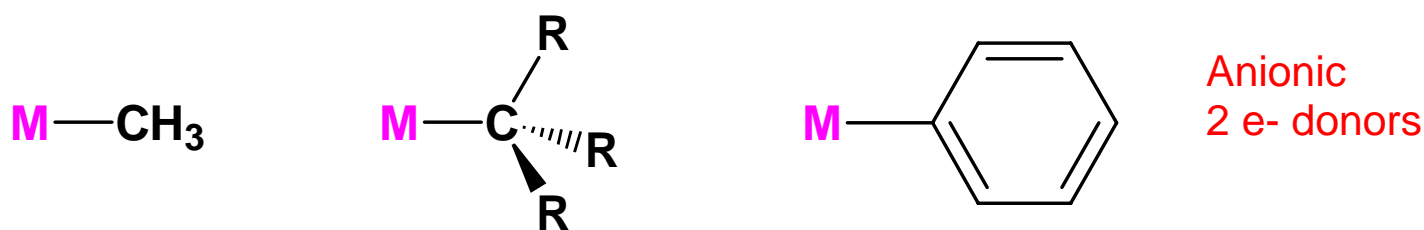

Alkyls are typically very **strong anionic σ -donors**, second only to hydrides. They have virtually no **π -acceptor** ability.

Increasing the carbon substitution (replacing hydrogens with hydrocarbon groups, methyl \longrightarrow ethyl \longrightarrow isopropyl) usually increases the donor strength, but steric factors can come into play and weaken the metal-alkyl bond (e.g., t-butyl groups are often too sterically hindered to bind well).

Replacing the hydrogens with fluorine atoms (very **electron withdrawing**) dramatically reduces the donor ability of the alkyl (aryl). For example, CF_3^- and $C_6F_5^-$ are not very strong donors.

Metal alkyls are also typically quite to extremely reactive to molecular O_2 , water, and a variety of other ligands and reagents. As with hydrides, they play a very important and active role in catalysis.

β -Hydride Elimination

One of the most common “side” reactions of alkyls is called the **β -hydride elimination** reaction:

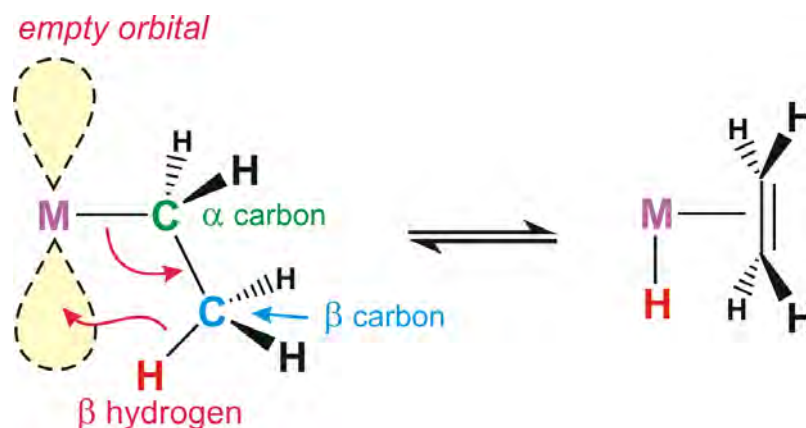

The main driving force for β -hydride elimination is the formation of a stronger M-H bond (almost always stronger than M-alkyl) and the generation of an alkene ligand that reduces the unsaturation of the metal complex. The reverse reaction, however, also can occur and is called a **migratory insertion**. This is very important in transition metal reaction chemistry and catalysis, as we will see in later chapters.

Note that in order to have a β -hydride elimination you MUST have an empty orbital on the metal cisoidal (next) to the alkyl ligand. You also must have β -hydrogens present on the alkyl.

In order to prepare stable M-alkyl complexes one, therefore, often needs to stay away from alkyls with β -hydrogens (or avoid metals with empty coordination sites). Some common ligands used to avoid β -hydride elimination reactions are shown below.

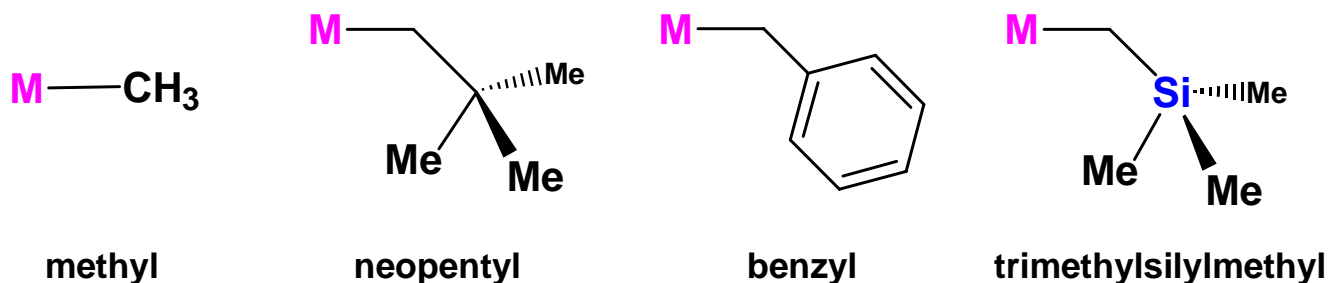

Problems:

a) Why doesn't a M-phenyl do a β -hydride elimination? Why?

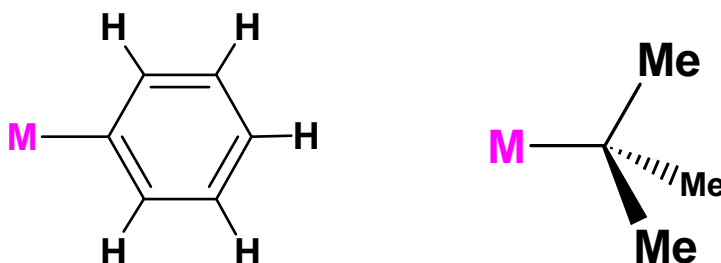

b) Would a 16 e- M-(*t*-butyl) complex be stable or not? Why?

α -Hydride Elimination

A less common reaction with metal alkyls is the α -hydride elimination, where a hydrogen atom on the α -carbon is added to the metal to generate a $M=CR_2$ (carbene or alkylidene) group and a hydride:

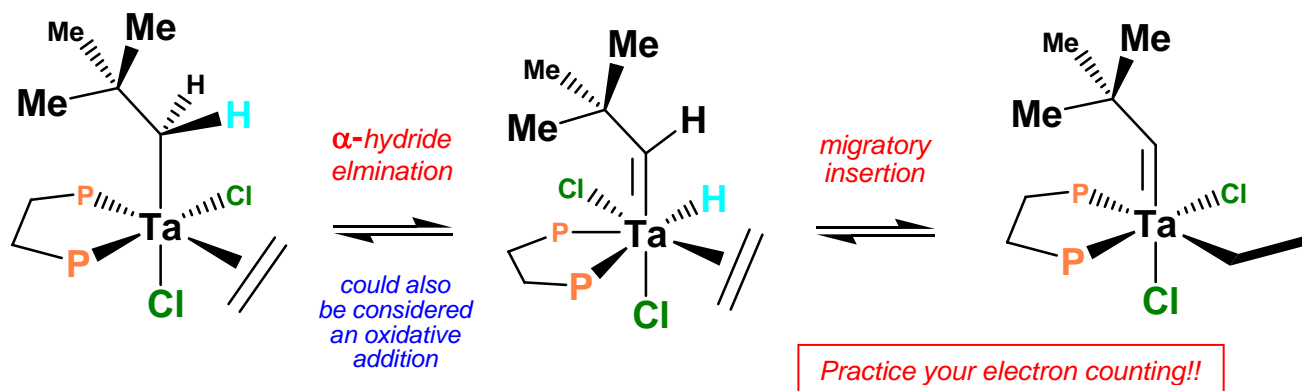

Note that just as with a β -hydride elimination, **it is important to have an empty orbital cis to the α -hydrogen in order to have the α -hydride elimination occur.** In the next section on carbene/alkylidene ligands, we will see that depending on how you electron count, an α -hydride elimination can also be considered to be a C-H bond **oxidative addition** (see that chapter as well).

Synthesis:

The most common way of making metal alkyls is to do what is called a **transmetalation**, that is react a transition metal halide with a **alkali** or **main group** metal alkyl, which is typically far more ionic and reactive:

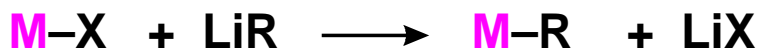

Other reactive alkyl reagents: $RMgX$ (Gignard), R_2Zn , R_2Hg , R_2Cu , AlR_3

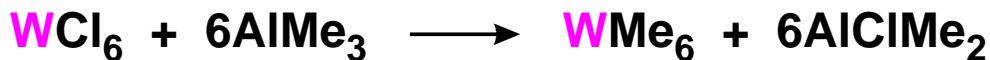

Problem: Based on core photoelectron spectroscopy, which complex is more electron-rich at the metal – $W(CH_3)_6$ or $W(CO)_6$?? Why?

The other common way of making M-alkyls is to react a moderately electron-rich metal center with an alkyl halide (RCl, RBr or RI):

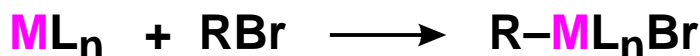

This, once again, is called an **oxidative addition**.

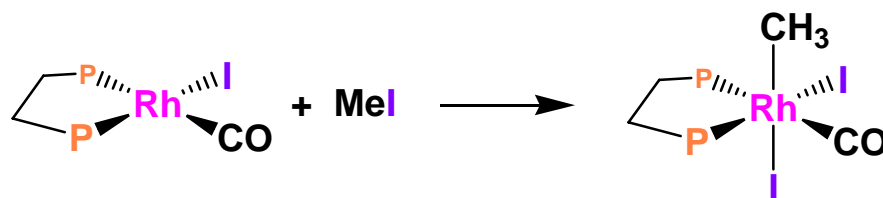

This will be discussed more fully in the **oxidative addition** reaction chapter.

Aryl Ligands

Aryl ligands are relatively strong **anionic** two electron donors, essentially just like alkyls.

Since they **cannot** easily **β -hydride eliminate** (formation of the benzyne intermediate is typically too unstable), metal aryl complexes

are usually relatively stable compared to alkyls with β -hydrogens. But “stable” is a relative term since transition metal aryl complexes are also quite air-sensitive and reactive.

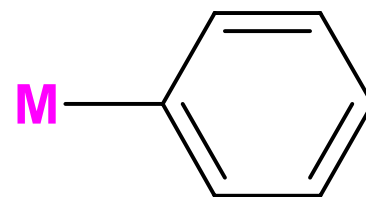

Aryls do have the potential for both π -donation and π -backbonding through the filled aryl π -orbitals and empty π^* antibonding orbitals. This can provide additional stability to a metal complex, depending on whether the metal needs additional electrons from the ligand or wants to dump excess electron density onto the ligand.

Problem: $Cp_2Re-CH_2CH_3$ is very stable under inert atmosphere, but $Cp_2Sc-CH_2CH_3$ readily decomposes. Why?

Fischer Carbenes

In 1964 Fischer's group prepared the first transition metal carbon double bond, which he called a carbene, after the very reactive neutral organic CR_2 fragment.



Ernst O. Fischer
Technical University of Munich,
Germany

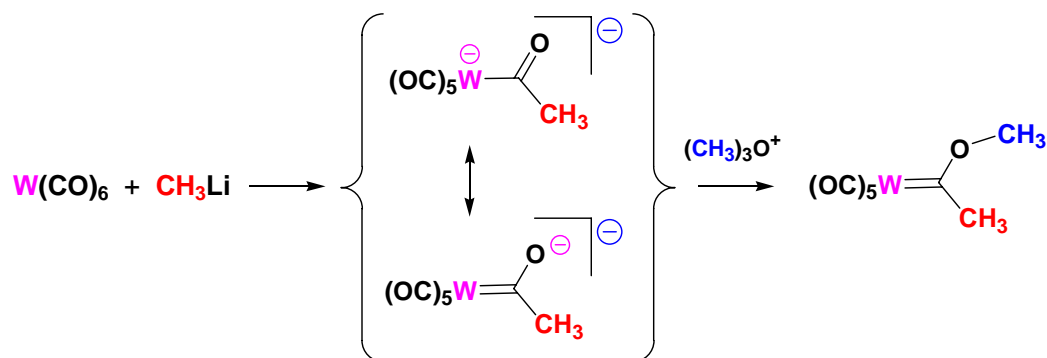

The reaction of Cr(CO)_6 with $\text{Li}[\text{N}(i\text{-Pr})_2]$, followed by reaction with Et_3O^+ generated the analogous Cr carbene complex with Et and $\text{N}(i\text{-Pr})_2$ groups on the carbene. A crystal structure of this complex revealed the following unusual features of the $\text{Cr}=\text{C}(\text{Et})[\text{N}(i\text{-Pr})_2]$ group:

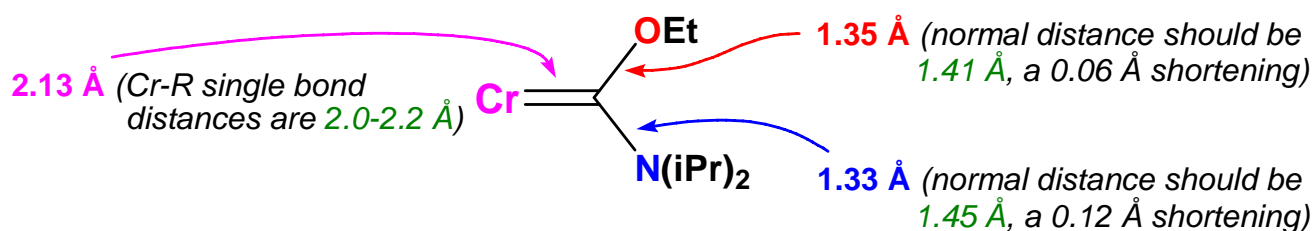

Thus, the X-ray structure indicated that the actual electronic structure of this “carbene” was really more like one of these resonance hybrids:

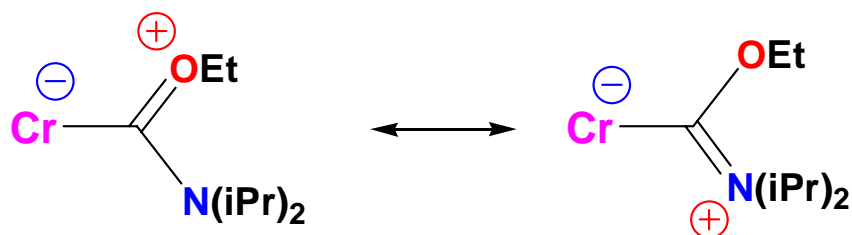

The presence of 5 electron-withdrawing CO ligands would certainly help “suck up” the formal negative charge that these resonance structures put on the metal.

The bonding description commonly used to describe **Fischer Carbenes** is to treat the carbene as a **neutral 2e- donor ligand** that really only makes a single bond to the metal (BUT, *we often draw it as a double bond!!*). In considering the carbene as a neutral ligand, it has one filled orbital (sp^2 hybrid) that donates its lone pair to an empty orbital on the metal in a typical ligand fashion. But it also has one empty orbital (pure p character) that wants to interact with a lone pair of electrons in order to form a stabilizing bonding interaction. This is a **singlet state** carbene formalism and the possible orbital interactions are shown below:

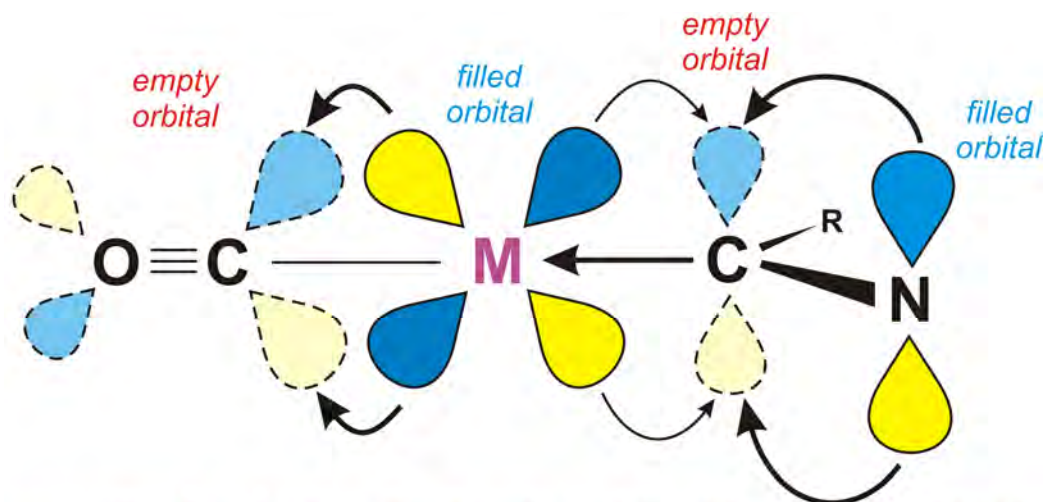

competition for π -backbonding from the metal and the lone pair orbital(s) on the functional group(s) to the carbene empty orbital (N and S the best, then O, Ph, and other π -donating or lone pair containing groups)

If the metal is electron deficient (perhaps due to all the good π -acceptor CO ligands) then it **can't** π -donate very well to the carbene. Thus we end up with a M-C single bond (*even though we draw a double bond!*) and some multiple bond character between the carbene carbon and the π -donor groups attached to it (like a NR_2 , OR, SR, Ph, etc).

Most **Fischer Carbenes** have d^6 metal configurations (**assuming that we electron count the carbene ligand as a neutral 2 e- donor**), but d^4 and d^8 systems are known.

The bond strength in **Fischer Carbenes** depends on several factors:

	Weak M=C	Strong M=C
Metal	Electron-deficient (electron withdrawing ligands like CO, NO, 1 st row metal, electronegative metal)	Electron-rich (electron donating ligands, 3 rd row metal)
Carbene groups	Good donating functional groups that can π -bond to the carbene (like NR ₂ , SR, OR, Ph); <i>more than one donating group really weakens the M-C bond!!</i>	Simple sigma donors like H or CH ₃ that can't π -donate to the Carbene carbon atom.

Note that most Fischer Carbenes favor the **weak bonding situation**, where the metal has a d^6 configuration (counting the carbene as neutral ligand), CO ligands, and the carbene has π -donating groups. The d^6 configuration naturally favors the **middle to late transition metals**. The strong carbene bonding situation is actually considerably more reactive, much like the reactivity of a C=C double bond vs. a C-C single bond. The C=C double bond is stronger than the single bond, but it is kinetically considerably more reactive due to its unsaturation.

Problem: Choose the complex that has the stronger M=C bond. Is there a large or small difference in bond strengths? Explain.

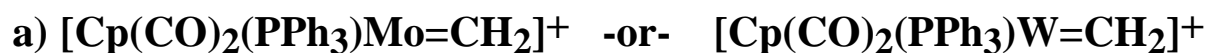

Problem: Order the following Fischer Carbenes from the weakest to the strongest M=C bond. Explain.

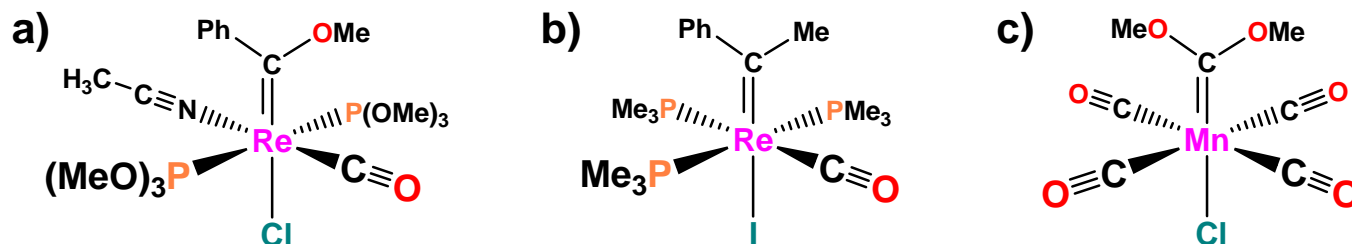

The other reactivity characteristic of **Fischer Carbenes** is that because the carbene carbon atom formally has an empty p orbital, it is very susceptible to **nucleophilic** attacks there. On the other hand, **electrophiles** tend to attack the metal center where there are a number of metal based lone pairs available.

Schrock Alkylidenes

In 1973 Richard Schrock, while working at DuPont central research, prepared the first early transition metal complex with a metal=carbon double bond:

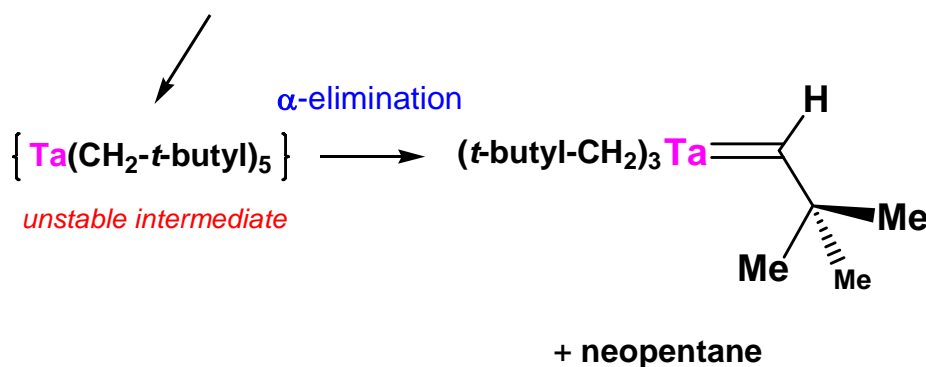

This turned out to be a key development in early transition metal chemistry.

Unlike most Fischer Carbenes, these early transition metal alkylidene complexes did have clear-cut and strong metal=carbon double bonds. For example, the crystal structure of the $\text{Cp}_2\text{Ta}(=\text{CH}_2)(\text{CH}_3)$ complex has the following bond distances:

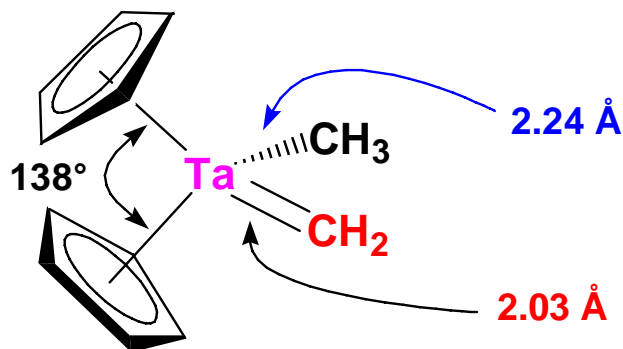

The Ta=CH₂ bond is distinctly shorter than the Ta-CH₃ single bond!

The reason that Schrock gave these “carbene” complexes a different name (alkylidenes) was not just because of the structural differences. These early transition metal **alkylidene** complexes had very different (almost opposite) reactivities compared to **Fischer Carbenes**:

Fischer Carbenes	Schrock Alkylidenes
Nucleophilic attacks at carbon atom of carbene (carbon is electron deficient)	Electrophilic attacks at carbon atom of alkylidene (carbon is electron-rich)
Electrophilic attacks on metal center (metal is more electron-rich, often d ⁶ 18 e- system)	Nucleophilic attacks on metal center (metal is electron-deficient, usually d ² or d ⁰ 16 or 14 e- count)
Carbene is <i>stabilized</i> by heteroatom groups that can π-bond to it. Likes NR ₂ , SR, OR, or Ph groups.	Alkylidene is <i>destabilized</i> by heteroatom groups that can π-bond to it. Strongly prefers H or simple alkyl groups.
Later transition metals favored, especially with d ⁶ counts (carbene as neutral 2e- donor ligand)	Early transition metals favored, especially with d ⁰ centers (alkylidene as dianionic 4e- donor)

The bonding description commonly used to describe **Schrock Alkylidenes** is to treat the alkylidene as a **dianionic 4e⁻ donor ligand**, which is what the electron counting and valence rules from the first chapter would indicate.

The filled *p*-orbital on the alkylidene carbon nicely explains the tendency for electrophiles to attack at this site, while in a Fischer carbene this same orbital is formally empty and thus susceptible to a nucleophilic attack.

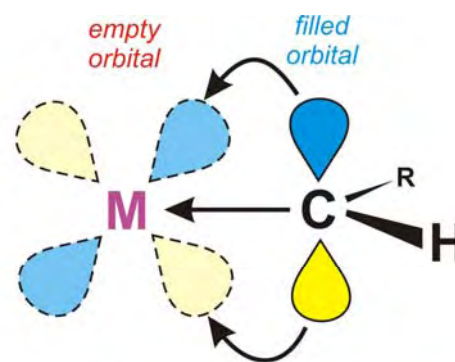

both the sp^2 and p orbitals on the alkylidene are filled (thus the -2 charge) and both can strongly donate to the empty orbitals on the early transition metal (only one empty d orbital is shown)

Similarly, the d^0 metal center in the typical Schrock alkylidene usually only has a 12 to 16 e⁻ count (often 14 e⁻), this means that there are several empty low energy orbitals that are very attractive to any nucleophile that can sterically access the metal center. In Fischer carbenes, the metal is typically d^6 and 18e⁻, thus there are no empty orbitals on the metal for a nucleophile to attack.

One other way to view a Schrock alkylidene is as a neutral ligand, just as with a Fischer carbene, but that it is in the **triplet carbene state** and interacting with a spin unpaired d^2 metal center:

The view of an alkylidene as a neutral triplet carbene forming a strong covalent double bond to a triplet metal center is very analogous to the covalent C=C double bond in organic chemistry.

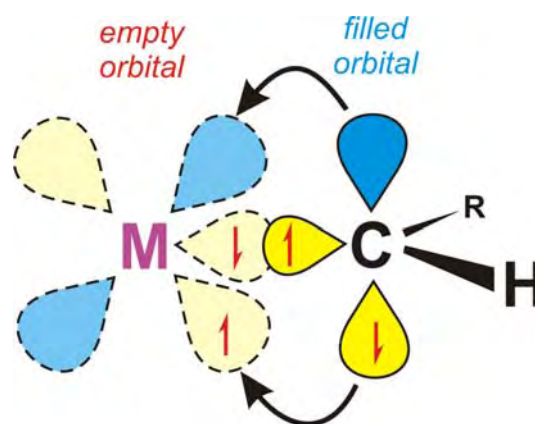

Molecular orbital (MO) diagrams for generic Schrock alkylidene and Fischer carbene ligands are shown below starting with both carbon fragments as neutral triplet (alkylidene) and singlet (carbene) groups:

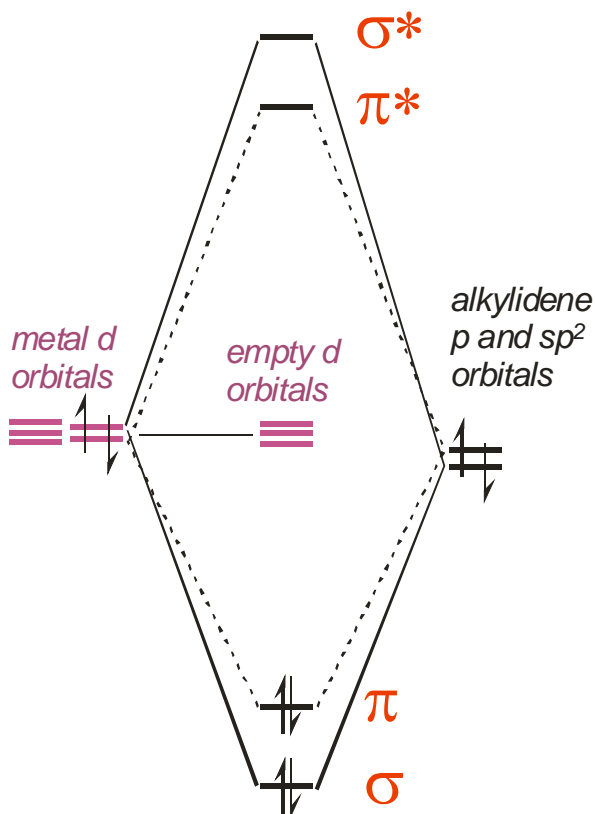

Schrock alkylidene

Metal = d^2
alkylidene triplet state
(Ta^{3+} , Nb^{3+} , etc)

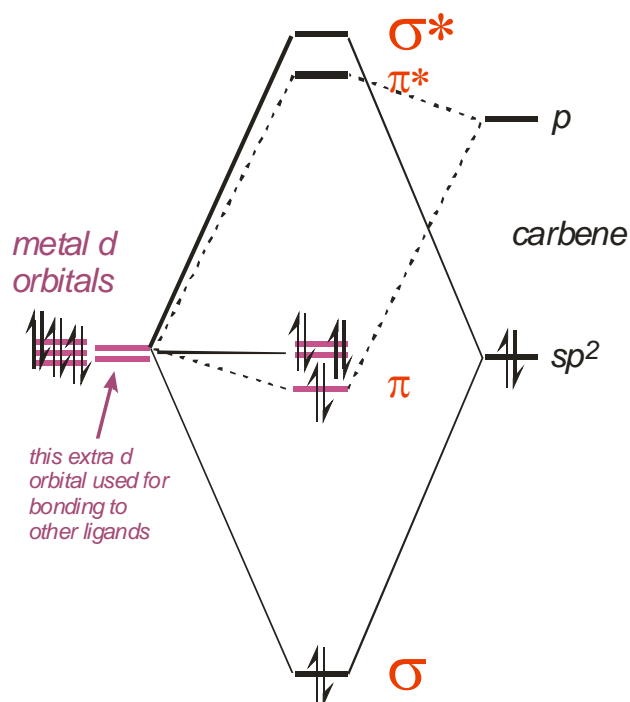

Fischer carbene

Metal = d^6
carbene singlet state
(Cr^0 , Mo^0 , Re^{+1} , etc)

Note that the higher energy early transition metal orbitals match up much better with the higher energy triplet alkylidene orbitals – this leads to considerably stronger covalent bonding (both MO diagrams are on the same energy scale).

So How Should I Electron Count??

The various methods of electron-counting **carbenes** and **alkylidenes** are:

- 1) **both** as **neutral 2 e- donor ligands** (but still draw a M=C double bond)
- 2) **both** as **dianionic 4 e- donor ligands**
- 3) **Fischer carbenes** as neutral 2 e- donor ligands. Typically group 6 or higher metals with a d^6 or d^8 electron count (sometimes d^4).
- 4) **Schrock alkylidenes** as dianionic 4 e- donor ligands. Typically group 4 or 5 metals with d^0 electron counts. Also later transition metals in high oxidation states (d^0 , d^2 , or d^4).

Of course, in order to do method 3 or 4, you have to realize whether you have a **Fischer** or **Schrock** system. This isn't always easy just looking at the complex. I recommend uniformly adopting methods 1 or 2.

It is somewhat important to be able to tell them apart since Schrock alkylidenes almost always have stronger (but often still very reactive) M=C bonds compared to Fischer carbenes. So on a question asking you to order a series of carbene and/or alkylidene complexes, it is generally important to figure out which is which. On this type of question I'll only give you a maximum of one Schrock alkylidene since the factors determining alkylidene bond strengths are not anywhere as clear cut as those for Fischer carbenes. On assignments, I will also generally give you clear cut examples.

As far as the overall electron-count is concerned, it DOESN'T matter which electron-counting method you use, since both give you the same overall electron-count!!

Example: Identify the following complexes as Fischer carbene or Schrock alkylidene.

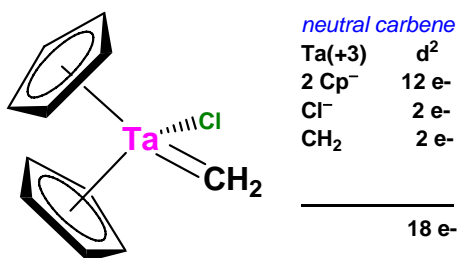

d^2 early TM using neutral carbene indicates a Schrock alkylidene complex

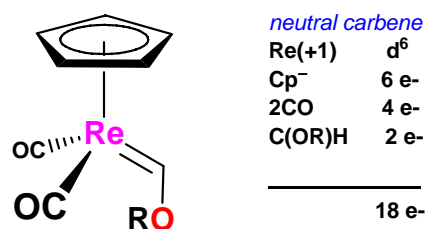

d^6 mid-TM using neutral carbene indicates a Fischer carbene complex

NMR Data

There isn't any clear cut way of distinguishing **Fischer carbenes** from **Schrock alkylidenes**. Some complexes, of course, will fall in between either category (shades of gray) and can't be clearly identified.

^{13}C NMR data is potentially one of the best ways of distinguishing between carbenes and alkylidenes because the chemical shift of the carbene carbon is usually quite sensitive to the chemical environment, electron density, and bonding factors. Unfortunately, the NMR data, although sometimes useful, generally won't allow one to identify when a system is a carbene or alkylidene, as shown in the table to the right.

Compound	^{13}C δ (ppm)	Class
$\text{Cp}_2\text{Ta}(=\text{CH}_2)(\text{Me})$	224	Schrock
$(\text{t-BuCH}_2)_3\text{Ta}(=\text{CH}(\text{t-Bu}))$	250	Schrock
$(\text{OC})_5\text{Cr}(=\text{CH}(\text{NMe}_2))$	246	Fischer
$(\text{OC})_5\text{Cr}(=\text{CPh}(\text{OMe}))$	351	Fischer
$(\text{OC})_5\text{Cr}(=\text{CPh}_2)$	399	Fischer

^1H NMR data has provided useful information about carbene rotational barriers. As with most double bonds, there is a rotational barrier for the $\text{M}=\text{CR}_2$ bond. For Schrock alkylidenes this is usually quite high ($\Delta G^\ddagger > 100$ kJ/mol), but for the more weakly bonded Fischer carbenes this can often be readily determined from variable temperature ^1H NMR studies.

The Cr carbene shown below actually has more double bond character between the carbene carbon and the -OMe group relative to the $\text{Cr}=\text{C}$ bond. At 25°C the methoxy CH_3 group shows a single ^1H NMR resonance indicating that there is relatively fast rotation about the C-OMe bond, while at -40°C there are two resonances for the methoxy CH_3 group, one for the *cis* and *trans* conformers, consistent with partial double bond character.

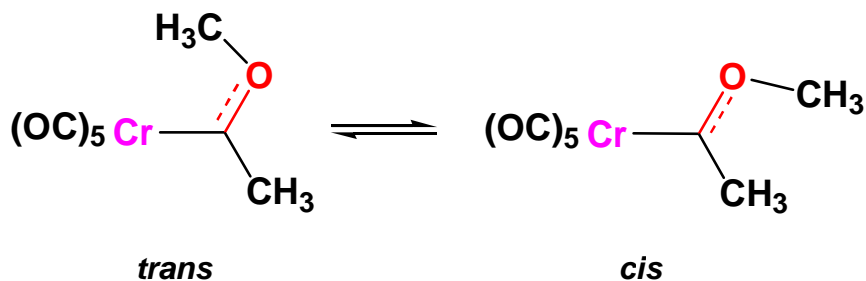

The Hot Carbene Ligand

The hottest “new” ligands are **imidazole-based N-heterocyclic carbenes** (NHC's) shown below. The flanking N atoms and R groups provides steric and electronic stabilization making this a reactive, but synthetically accessible ligand.

NHC's are usually strong σ -donors, often exceeding the donor ability of an alkylated PR_3 ligand (see plot below). The backbone double bond may or may not be present (along with other R groups).

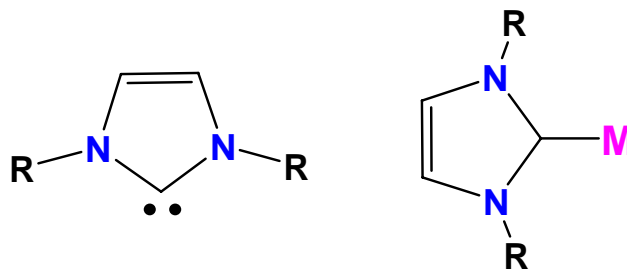

Note that this ligand is usually drawn with a single bond to the metal. But it is NOT an anionic alkyl and there is NOT a H atom on the carbon atom bound to the metal center!! It is typically electron-counted as a neutral Fischer carbene. Because of the two

flanking N atoms that can π -donate into the empty carbene p -orbital, it is not considered to be a good π -acceptor. This π -donation, however, does help make it a stronger σ -donor by compensating for the σ -withdrawing electronegative N atoms.

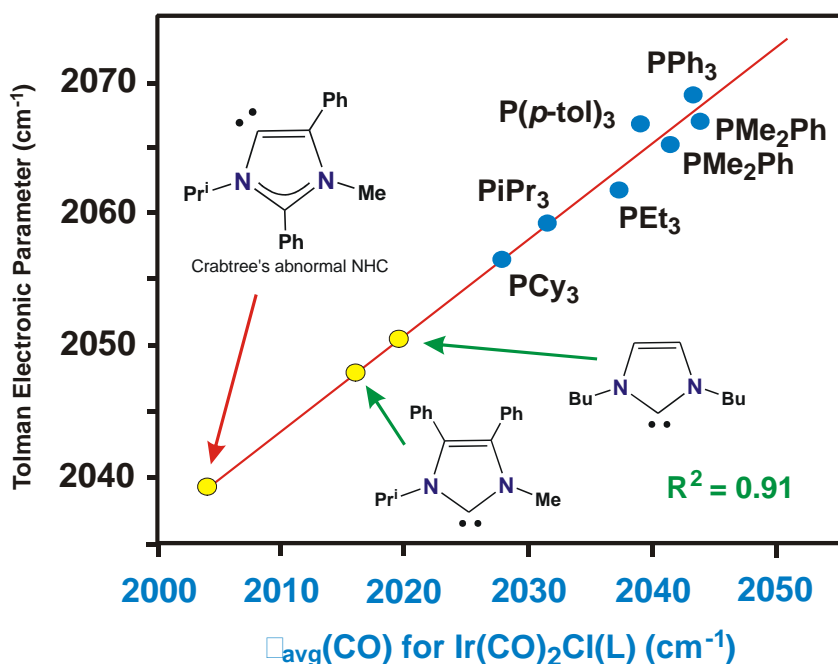

Some References to N-heterocyclic carbenes:

Wolfgang A. Herrmann, “N-Heterocyclic Carbenes. Part 31. N-Heterocyclic Carbenes: A New Concept in Organometallic Catalysis.” *Angew. Chem. Int. Ed.*, **2002**, *41*, 1290-1309.

Robert H. Crabtree (& coworkers), “Abnormal C5-Bound N-Heterocyclic Carbenes: Extremely Strong Electron Donor Ligands and Their Iridium(I) and Iridium(III) Complexes.” *Organometallics*, **2004**, *23*, 2461-2468 (modified νCO plot above from this reference).

Problem: Order the following M=C complexes from the one with the highest M=CR₂ rotational barrier to the lowest. What factors affect the M=C rotational barrier? Identify each complex as either a Fisher carbene or a Schrock alkylidene.

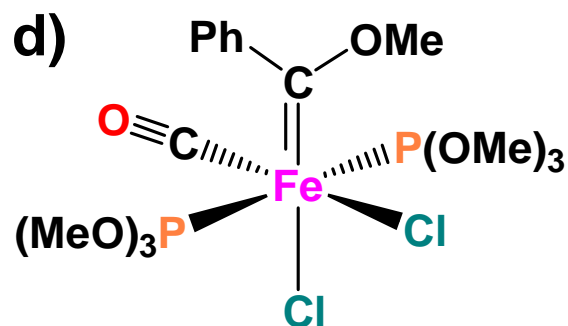
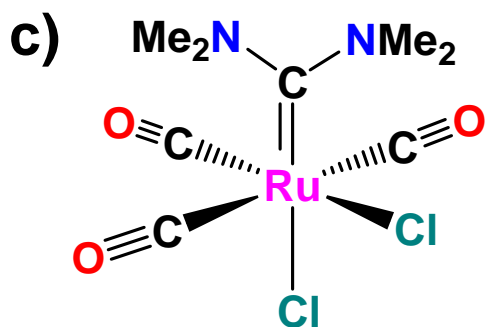
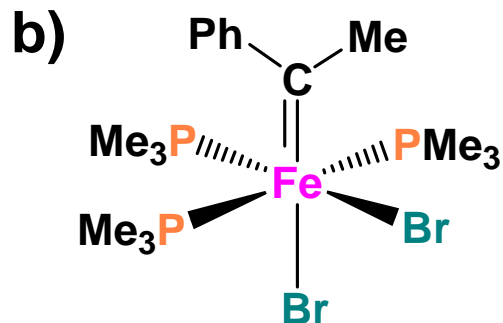
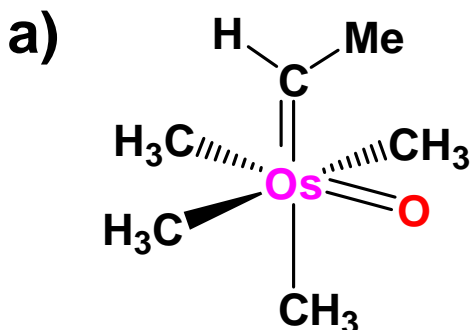

Carbynes/Alkylidyne



E. O. Fischer accidentally prepared the first $M \equiv C - R$ triple bonded compound in 1973:

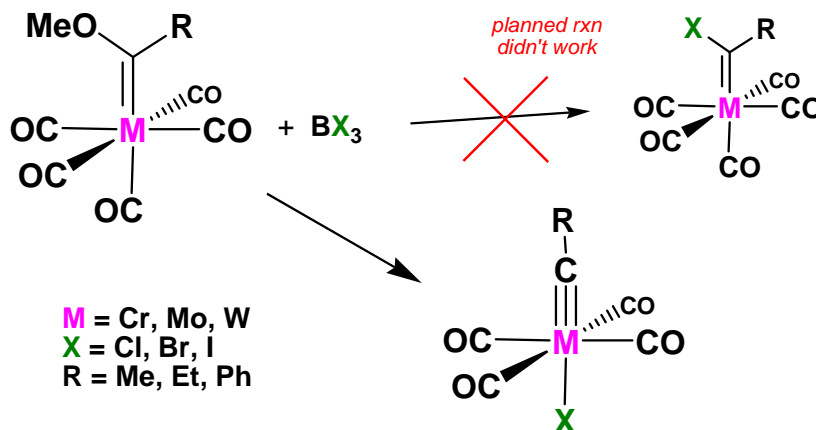

He called this a **carbyne** after **alkyne**, which refers to a $C \equiv C$ triple bond. Early transition metal versions were prepared first by Schrock in 1978 via α -deprotonation of the alkylidene:

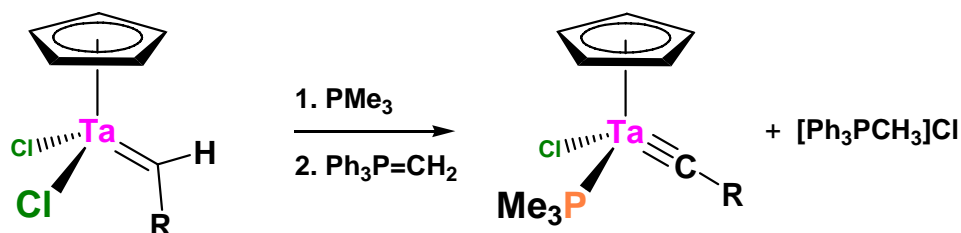

These were called **alkylidyne**s by Schrock. Fortunately, while there are some differences between early and later transition metal carbon triple bonds, we can treat them as basically being the same. Thus, one can simply treat **carbynes** and **alkylidyne**s as trianionic (-3) $6e^-$ donating ligands. They are very strong donors as might be expected from the relatively low electronegativity of carbon and the -3 formal charge.

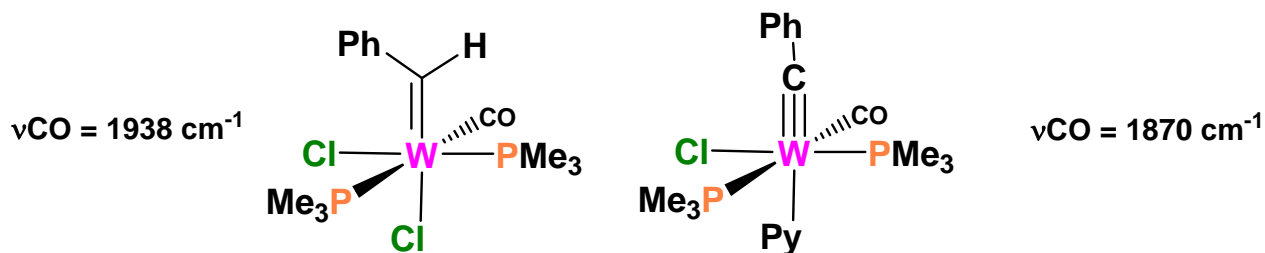

An remarkable X-ray structure of one of Schrock's compounds that contains a W-C single bond, a W=C double bond, and a W≡C triple bond is shown below and beautifully illustrates the dramatic and progressive shortening of the W-C bonds as you increase the bond order:

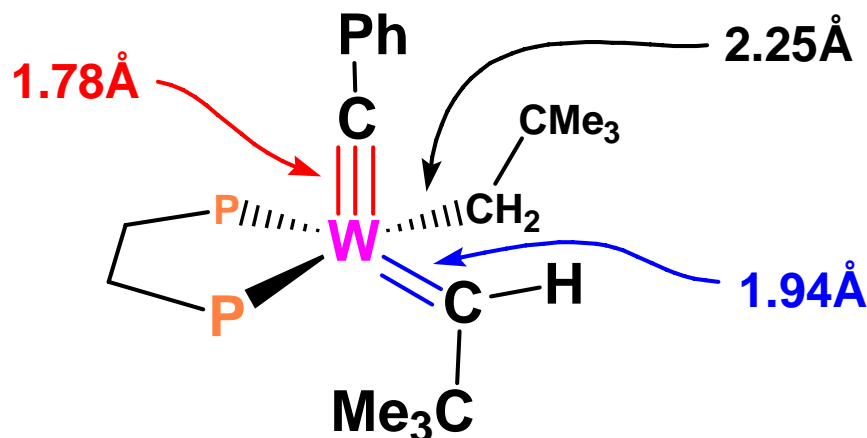

Carbynes are also rather good bridging groups for two or three metal centers. When bridging two metals, one usually assumes delocalized bonding and that the carbyne donates 3e⁻ to each metal center:

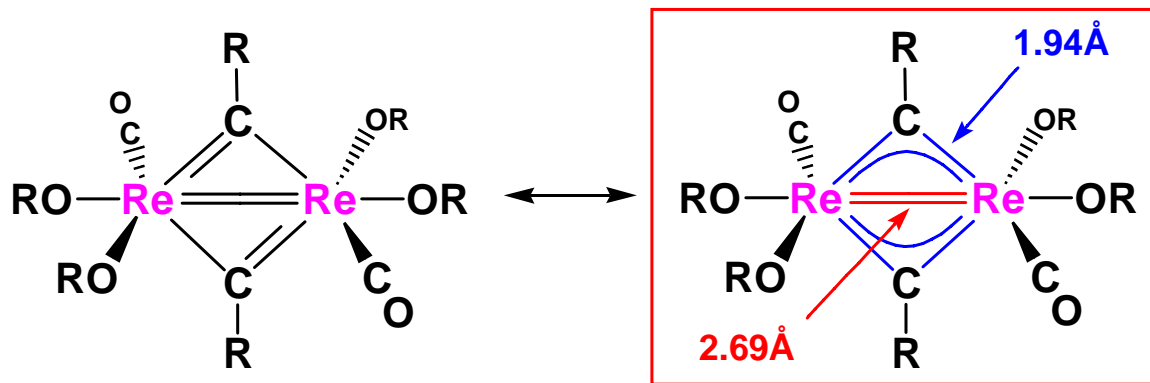

X-ray structures (as the one above) usually show equal M-(μ-carbyne) bond distances completely supporting the idea that the bonding is delocalized. When there isn't M-M bonding present, most authors will draw a circle in the dimetallo-cyclobutane ring to indicate delocalized bonding (that doesn't necessarily mean it is aromatic, but it may be depending on the π- and d-electron count).

Problem: Which of the following ligands will coordinate the strongest to the empty coordination site on the metal complex shown below.



Problem: Professor Standshort instructed his graduate student Fred Fasthands to make a $\text{Pd(alkyl)}_2(\text{PPh}_3)_2$ complex. Fred immediately rushed into the lab and ran the following reaction:

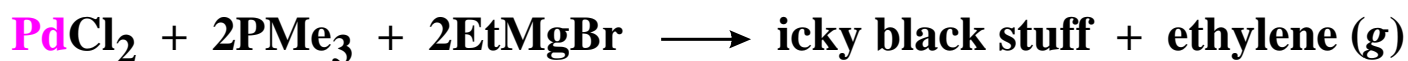

Thelma Thinksalot, a younger yet wiser undergraduate in the lab (who was taking Prof. Standshort's organometallics class), noticed this and suggested that Fred use the exact same conditions *except* that he should use PhCH_2MgBr (benzyl Grignard) instead of EtMgBr . Fred frantically did so and found that the reaction now gave a **quantitative yield** of orange $\text{Pd(CH}_2\text{Ph)}_2(\text{PMe}_3)_2$.

Why didn't the first reaction work and why did the second work fine? What other alkyl groups might work?

Alkenes & Alkynes

Alkenes act as neutral $2e^-$ donors (per C=C double bond). Due to the presence of empty π^* antibonding orbitals, there is the possibility of some π -backbonding:

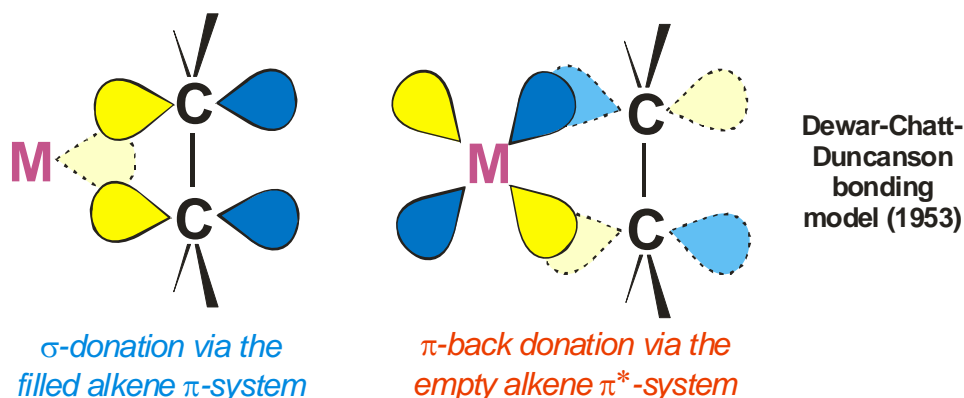

Alkenes are typically relatively weakly coordinating ligands. They are also extremely important substrates for catalytic reactions. The strongest alkene-metal bonds occur with **third row metals** (as with almost all ligands) and when one can get more π -backbonding to occur. The amount of π -backbonding depends strongly on how **electron-rich** the metal center is and whether or not there are **electron-withdrawing groups** on the alkene to make it a better acceptor ligand.

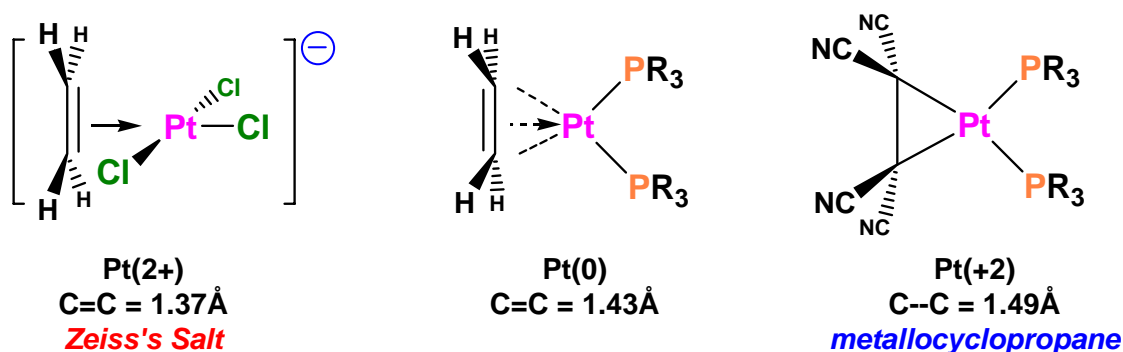

In extreme cases, as shown above to the right, if the metal is electron-rich enough and if there are electron-withdrawing groups on the alkene (like the CN's), one can actually get a formal **oxidation** of the metal via the transfer of $2e^-$ to the alkene to form a dianionic **metallocyclopropane** ligand that is now coordinated via two anionic alkyl σ -bonds (thus the assignment of Pt(+2)).

Another interesting comparison is shown to the right where we have two different alkenes coordinating to the same metal center. The electron-withdrawing **fluorine** groups on the $\text{F}_2\text{C}=\text{CF}_2$ alkene makes it a better π -acceptor ligand. This *weakens* the $\text{C}=\text{C}$ bond, but *strengthens* the alkene-metal bond.

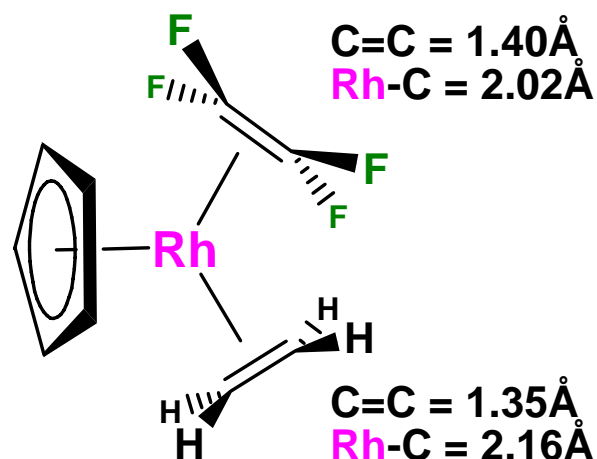

Another series of structures is shown below for butadiene, $\text{Fe}(\eta^4\text{-C}_4\text{H}_6)(\text{CO})_3$, and $\text{Cp}_2\text{Zr}(\eta^4\text{-C}_4\text{H}_6)$:

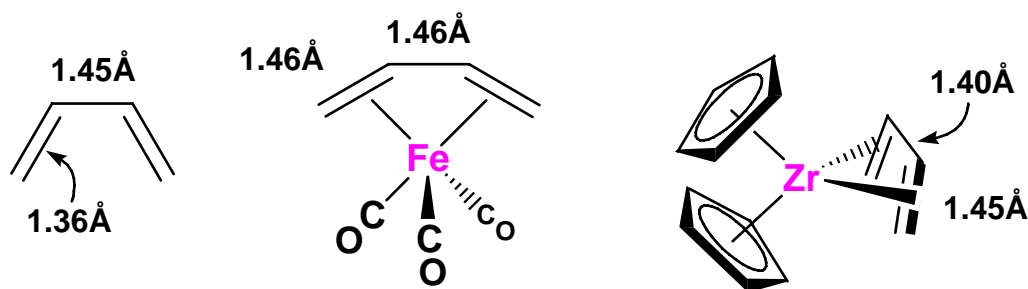

In this series one can see that the combination of π -backdonation from the Fe and σ -donation from the alkenes to the Fe *weaken* and *lengthen* the $\text{C}=\text{C}$ bond. In the Zr complex, however, we see an interesting reversal where the single bond across the back of the butadiene shortens quite a bit. What is happening here is that the Zr is in a very low oxidation state (+2, but it really wants to be +4) and is, therefore, extremely **electron-rich**. So electron-rich that it transfers two electrons to the butadiene via the π -backdonation and generates a **metallocyclopentene** resonance structure, shown schematically to the right.

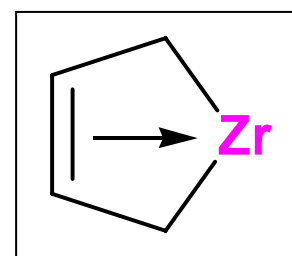

More Electronic Effects

Electronic effects with **alkenes** can often be somewhat easily monitored using infrared (IR) spectroscopy, much as with CO ligands. The more **π -backbonding**, the **weaker** the C=C double bond and the **lower** the C=C stretching frequency in the IR. The table below shows a series of alkene compounds with differing amounts of **σ -donation** and **π -backbonding**. Note that both **weaken** the C=C bond and **lower** the stretching frequency, although the **π -backbonding** has by far the larger effect.

The Ag⁺ complex is believed to have **no** π -backbonding, so the drop in the C=C stretching frequency is completely due to σ -donation from the alkene to the Ag⁺.

Carefully examine the compounds in the table and see if the changes in the C=C stretching frequencies make sense relative to your perceptions of how electron-rich the metal center is (allowing you to judge the amount of π -backdonation) and how strongly the alkene might be σ -bonding to the metal (a relatively minor contribution compared to the effect of **π -backdonation**).

Ethylene Complex	$\nu_{\text{C=C}}$ (cm ⁻¹)
Free Ethylene	1623
[Ag(H ₂ C=CH ₂) ₂] ⁺	1584
Fe(CO) ₄ (H ₂ C=CH ₂)	1551
[Re(CO) ₄ (H ₂ C=CH ₂) ₂] ⁺	1539
[CpFe(CO) ₂ (H ₂ C=CH ₂)] ⁺	1527
Pd ₂ Cl ₄ (H ₂ C=CH ₂) ₂	1525
[PtCl ₃ (H ₂ C=CH ₂)] ⁻	1516
CpMn(CO) ₂ (H ₂ C=CH ₂)	1508
Pt ₂ Cl ₄ (H ₂ C=CH ₂) ₂	1506
CpRh(H ₂ C=CH ₂) ₂	1493

The **thermodynamic stability** of metal-alkene complexes is strongly affected by the nature of the alkene (and metal):

- 1) **Electron-withdrawing** groups on the alkene generally increase the strength of the metal-alkene bonding, while **electron-donating** groups generally decrease the stability.
- 2) In cases where **cis-trans** isomerism is possible, the more stable complex is almost always formed by the **cis-alkene** (steric factors).

- 3) Metal complexes of ring-strained cycloalkenes (e.g., cyclopropene) display higher than expected stability. The ring strain raised the energy of the cycloalkene ring system making it a better donor to the metal center (better orbital energy matching). See the next section on cyclobutadiene for a particularly remarkable example.
- 4) Chelating dienes show the expected stabilization from the **chelate effect**. The most common examples are **norbornadiene** and **cyclooctadiene** shown below. Note that these can still be easily substituted off the metal by stronger coordinating ligands such as phosphines.

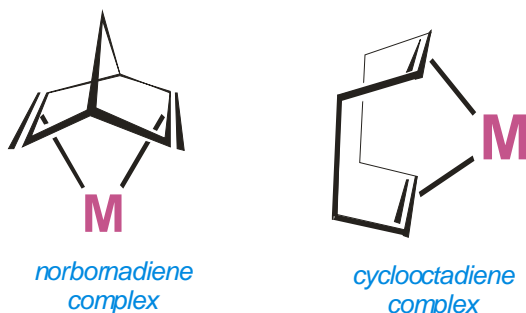

- 5) **Third-row metals** form the strongest bonds and most stable complexes (as with most ligands).

Problem: To which of the following (each with a single open coordination site) will **trifluoroethylene** bond to the most strongly? Why?

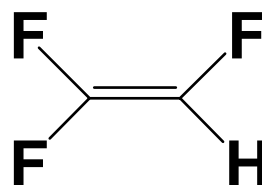
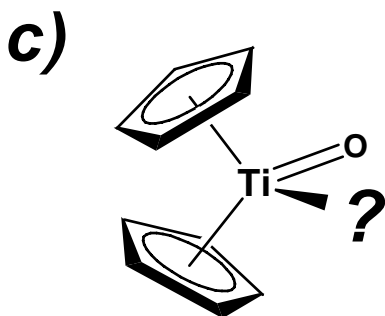
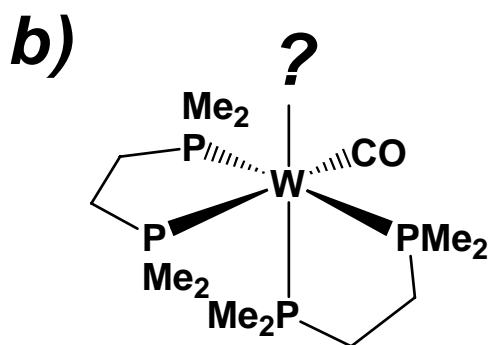
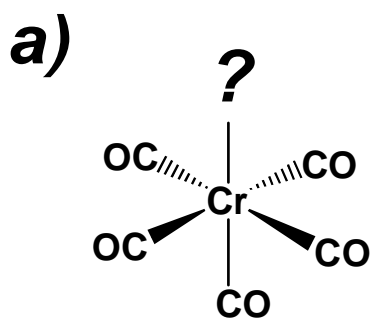

Cyclobutadiene

Cyclic conjugated π -systems are aromatic if the number of π -electrons equals $4n + 2$ (where $n = \text{an integer}$). Cyclobutadiene is an anti-aromatic since it has 4 π -electrons. The anti-aromaticity combined with the ring strain makes this simple molecule too unstable to exist as a free organic compound.

A triumph of the early days of organometallic chemistry was the successful synthesis of $(\eta^4\text{-C}_4\text{H}_4)_2\text{Ni}_2(\mu\text{-Cl})_2\text{Cl}_2$, a stable metal-coordinated butadiene molecule, by Criegee in 1959. This was actually predicted theoretically by Longuet-Higgins and Orgel in 1956 using an early form of molecular orbital theory.

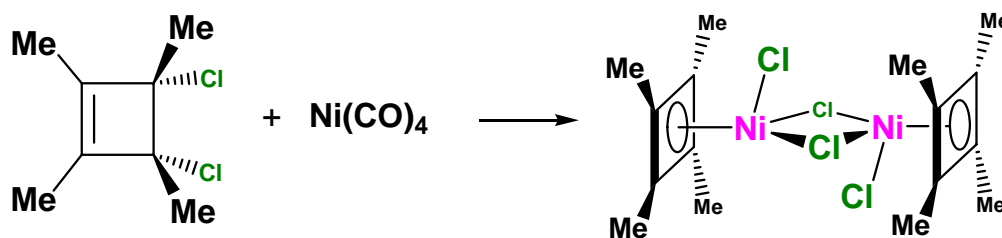

An even simpler route was discovered shortly after this involving the cyclodimerization of diphenyl acetylene by $\text{Fe}(\text{CO})_5$:

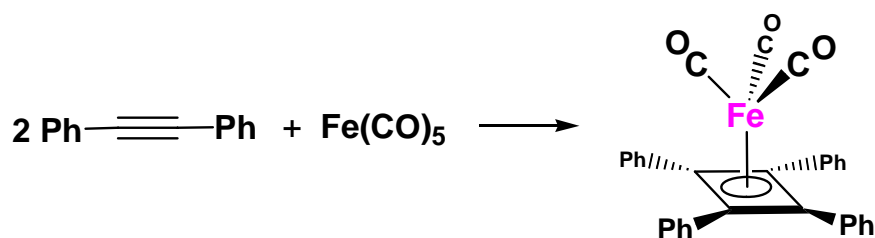

The high stability of a cyclobutadiene coordinated to a metal arises from the mixing of the 4 π electrons on the cyclobutadiene with one of the metal d orbitals that has 2 e^- and the right symmetry to mix in and form a 6 π electron aromatic system! This is shown on the MO diagram on the next page. Note that the high energy (instability) of the non-bonding cyclobutadiene highest occupied molecular orbital (HOMO) allows it to interact extremely well with the metal orbitals that are at approximately the same energy.

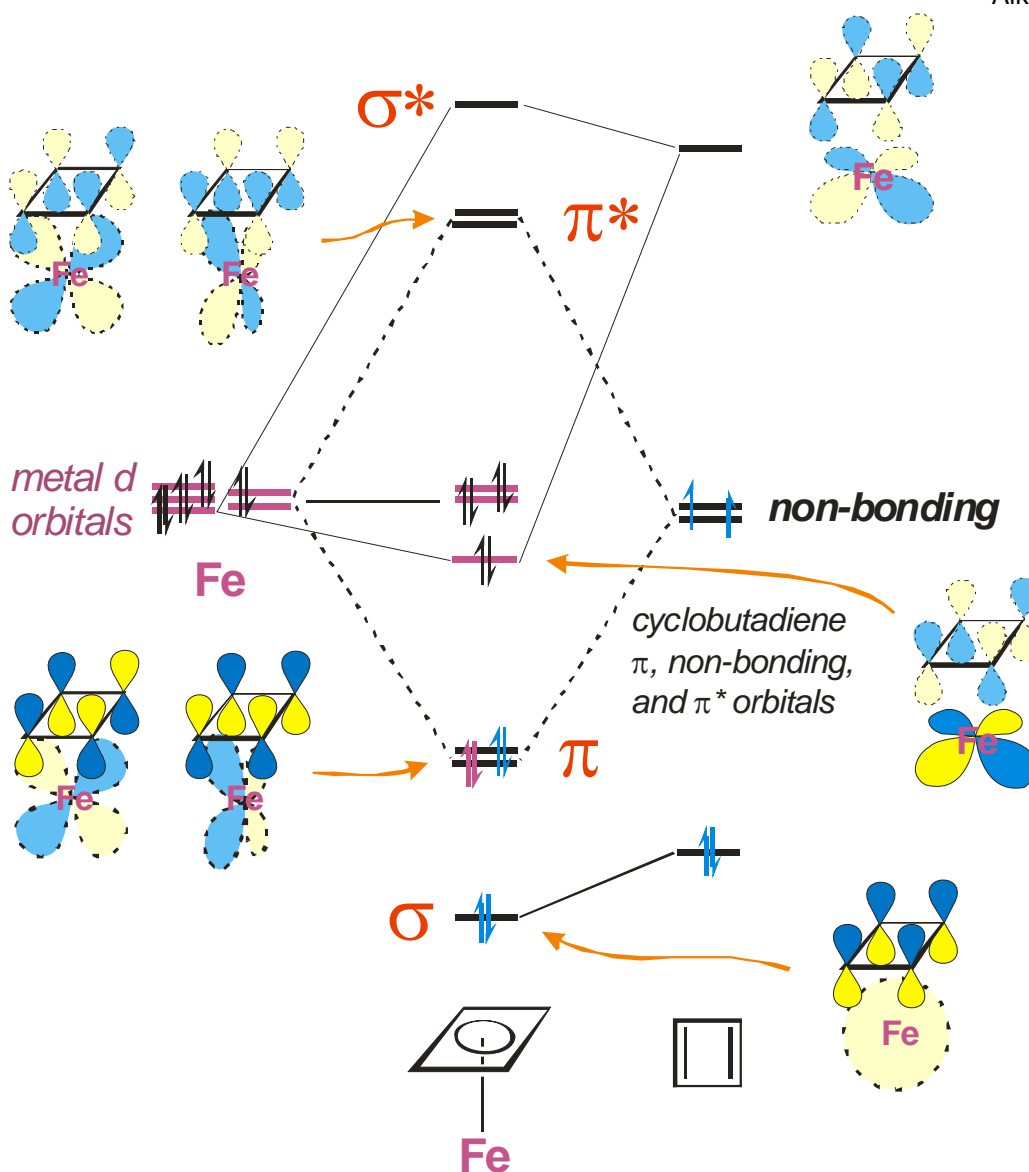

Alkynes

Alkynes are essentially like alkenes, only with another perpendicular pair of π -electrons. Thus they can act as neutral 2 or 4 e- donors, depending on the needs of the metal center. They are also much better bridging ligands because of this second set of π -electrons.

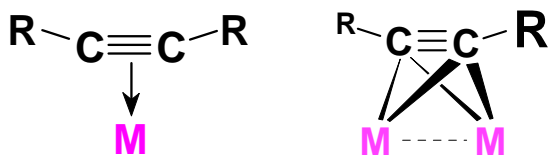

Note how the bridging alkyne is drawn. This indicates a perpendicular bridging mode and that both carbons are interacting equally with both metals (the alkyne is donating 2e- to each metal). It does NOT indicate that each carbon has 6 bonds to it !!

Alkynes are better donors compared to alkenes and typically coordinate far more readily to a metal for steric (more open, less hindered) and electronic (better donor, 2 or 4e- bonding) reasons. They are also quite a

bit more reactive for doing C-C coupling (see the Fe mediated cyclo-dimerization example for making the substituted metal-bound butadiene on the previous page) and other reactions.

When alkynes bridge, they almost always do so perpendicular to the M-M axis, the parallel bridging mode is known, but quite rare:

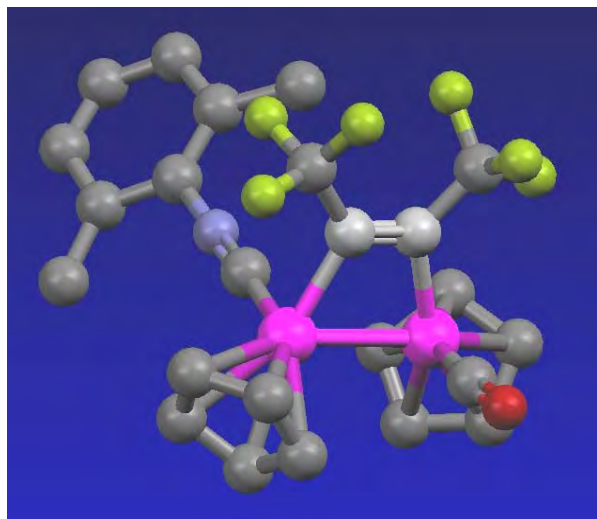

$\text{Cp}_2\text{Rh}_2[\mu\text{-(CF}_3\text{C}\equiv\text{CCF}_3\text{)](CO)(\text{CNR})$

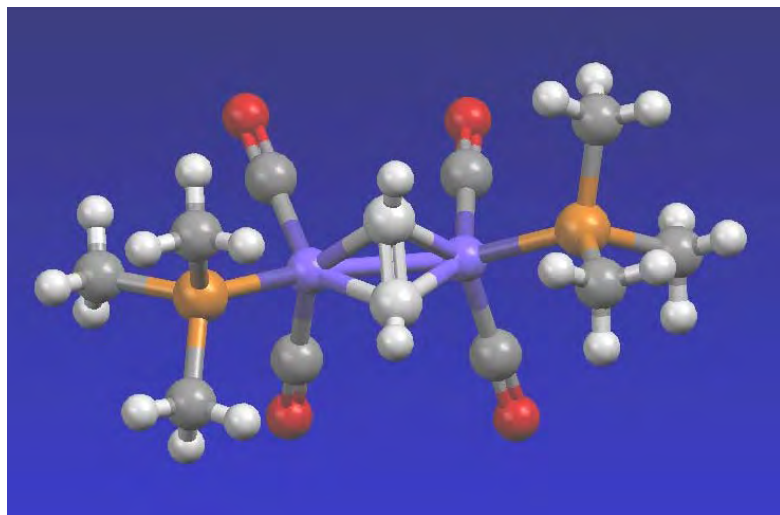

$\text{Co}_2[\mu\text{-(HC}\equiv\text{CH)](CO)}_4(\text{PMe}_3)_2$

Alkynes also have a strong tendency to bridge more than two metals in cluster compounds.

Problem: The $\text{Cp}_2\text{Rh}_2[\mu\text{-(CF}_3\text{C}\equiv\text{CCF}_3\text{)](CO)(\text{CNR})$ complex shown above has a Rh-Rh bond distance of 2.67 Å, strongly indicating a covalent bond between the rhodium atoms. How would you electron count this complex to accommodate a Rh-Rh covalent bond?

Problem: Which of the following ligands will coordinate the most strongly to a generic metal center (not too electron-rich or deficient, with enough open coordination sites)?

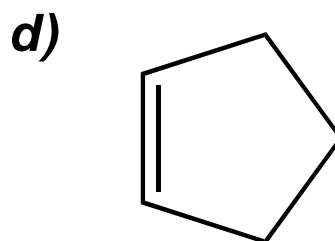
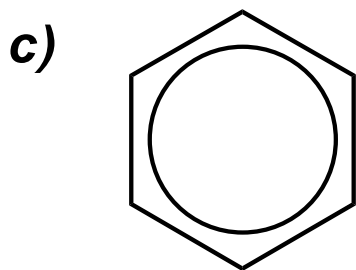
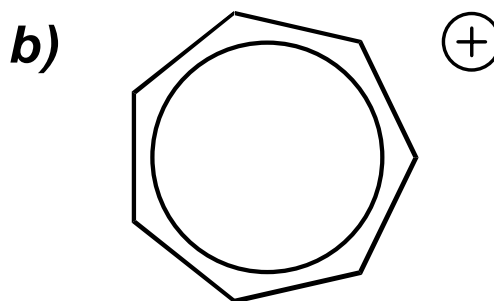
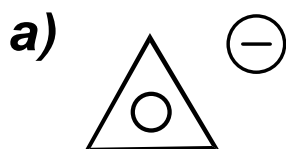

Arenes

Arenes (benzene being the simplest member of this family) typically coordinate in an η^6 fashion and as such are **neutral 6 e- donors**, although they can adopt lower coordination modes (η^4 and η^2).

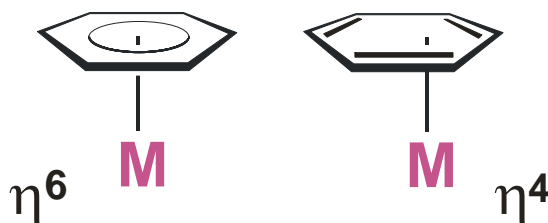

Synthesis: The first metal-benzene complex was prepared in 1955 by Fischer and Hafner:

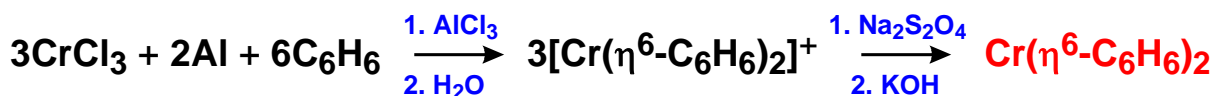

Limitations: Low yield, messy, difficult to isolate organometallic product. Also the arene must be inert towards the very reactive AlCl_3 . Alkylated arenes are isomerized by AlCl_3 . Arenes with substituents that have lone pairs available (e.g., haloarenes, anilines, phenols, etc.) are also unsuitable since they can bind to the AlCl_3 and inhibit the reaction.

Metal-atom vapor synthesis was first used by Timms in 1969 to prepare $\text{Cr}(\text{C}_6\text{H}_6)_2$. This involved the evaporation of elemental metals under high vacuum by heating them to very high temperatures (either resistively or by electron-beam impact). The evaporated metal atoms were condensed into a layer of frozen ligand and solvent (sometimes the same) coating the inside of a glass reaction flask at liquid nitrogen temperatures. Warming the flask up to the melting point of the solvent allowed the atomic metal and ligands to directly react to make the metal-ligand complex. Malcom Green, Ken Kabunde, and Philip Skell were all researchers actively involved in this area in the 70's.

Limitation: Metal atom vapor reactor is very expensive and difficult to maintain.

Some Properties of Metal-bis(arene) Complexes

Complex	Color	mp/°C	Miscellaneous
Ti(C ₆ H ₆) ₂	red	-	air-sensitive, autocatalytic decomposition in aromatic solvents
V(C ₆ H ₆) ₂	red	227	very air-sensitive, paramagnetic, reducible to [V(C ₆ H ₆) ₂] ⁻
V(C ₆ H ₅ F) ₂	red	-	air-sensitive
Nb(C ₆ H ₆) ₂	purple	-	very air-sensitive, paramagnetic, decomposes at ca. 90°C
Cr(C ₆ H ₆) ₂	brown	284	air-sensitive, the cation [Cr(C ₆ H ₆) ₂] ⁺ is air-stable. E° = -0.69 V in DME against SCE
Mo(C ₆ H ₆) ₂	green	115	very air-sensitive
W(C ₆ H ₆) ₂	yellow-green	160	less air-sensitive than Mo(C ₆ H ₆) ₂
[Mn(C ₆ Me ₆) ₂] ⁺	pale pink	-	diamagnetic
[Fe(C ₆ Me ₆) ₂] ²⁺	orange	-	reducible to [Fe(C ₆ Me ₆) ₂] ⁺ , violet, and to Fe(C ₆ Me ₆) ₂ , black, paramagnetic, extremely air-sensitive
[Ru(C ₆ Me ₆) ₂] ²⁺	colorless	-	air-stable, diamagnetic; reducible to Ru(C ₆ Me ₆) ₂ , orange, diamagnetic, very air-sensitive
[Co(C ₆ Me ₆) ₂] ⁺	yellow	-	Paramagnetic; reducible to Co(C ₆ Me ₆) ₂ , very air-sensitive

Adapted from Elschenbroich & Salzer, "Organometallics", VCH, 1989

π-Backbonding

An interesting aspect of metal-arene complexes is that π-backdonation plays a relatively important role in the bonding and chemistry. Arenes often do not coordinate very strongly to metals, but as one can tell from the list above, they do tend to favor metals in low oxidation states and often generate surprisingly stable complexes. Cr(C₆H₆)₂, for example, is kinetically inert to most substitution reactions, no doubt due to its 18 e-configuration, but also due to the mix of π-bonding and backbonding. But remember that CO and NO⁺ are far, far stronger π-backbonding ligands.

Structural Features

The parallel sandwich structures have the following features:

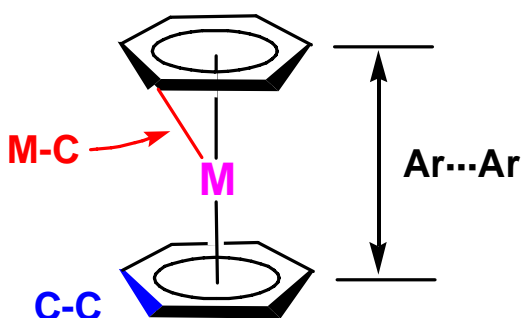

M	Distances (Å)		
	M-C	Ar \cdots Ar	C-C
Benzene	--	--	1.39
Ti	2.22	3.48	1.38
Nb	2.33	3.72	1.41
Cr	2.14	3.21	1.42
[Cr] ⁺	2.10	3.20	1.36
Me ₆ -[Fe] ²⁺	2.14	3.26	1.38
Me ₆ -[Ru] ²⁺	2.25	3.50	1.40
[Ru] ²⁺	2.22	3.42	1.42

Note that the C-C bond distances in the arene are not a particularly reliable gauge of the amount of π -backbonding, which in turn indicates that there probably is not a large amount occurring. The decrease in ring separation in going from $[Ru(C_6H_6)_2]^{2+}$ to the hexamethylbenzene complex, $[Ru(C_6Me_6)_2]^{2+}$ is caused by the increased electron density on the hexamethylbenzene that makes it more electron-rich and a better donor group (although that doesn't always lead to bond shortening). The Cr-C shortening in the cationic complex probably results from the contraction of the Cr d orbitals due to the localized positive charge.

Problem: The crystal structure of $[Cr(C_6H_6)_2]^+$ on the right clearly shows that the hydrogen atoms on the benzene distinctly lean in towards the metal center. Explain why.

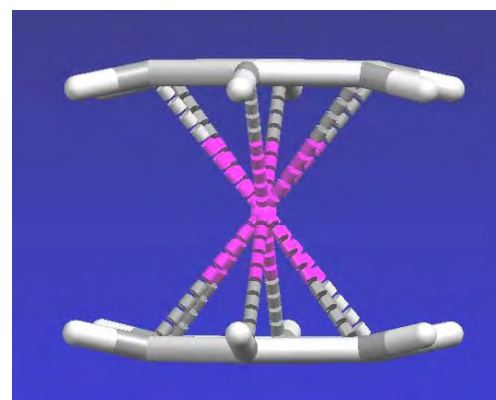

A dramatic example of the “power” of the 18e- electronic configuration is seen for the $[\text{Ru}(\text{C}_6\text{Me}_6)_2]^{2+}$ complex. This can be reduced to neutral $\text{Ru}(\text{C}_6\text{Me}_6)_2$, but electron-counting with two $\eta^6\text{-C}_6\text{Me}_6$ ligands gives you a 20e- complex. Violations of the 20e- rule are most common for first row metals where the metal-ligand bonding interactions are weaker leading to less destabilization when one occupies an M-L antibonding orbital when going past 18e-. But for 2nd and 3rd row metals that have increasingly stronger metal-ligand bonding, going past 18e- costs considerably more from a stability viewpoint.

Indeed, the structure of $\text{Ru}(\text{C}_6\text{Me}_6)_2$ (shown to the right) reveals that one of the arene rings is strongly folded to give a 4e- η^4 -coordination geometry. Thus, the correct formulation of this compound is $\text{Ru}(\eta^4\text{-C}_6\text{Me}_6)(\eta^6\text{-C}_6\text{Me}_6)$, which does give an 18e- count.

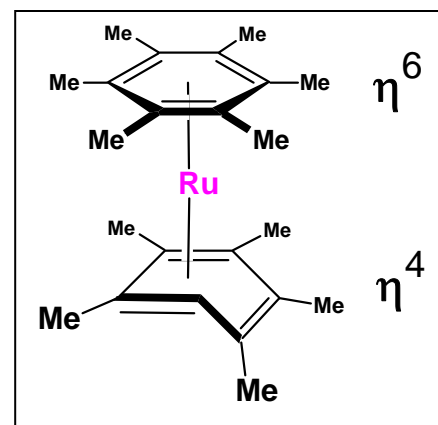

Problem: In which of the following complexes should the η^6 -benzene ligand coordinate the strongest?

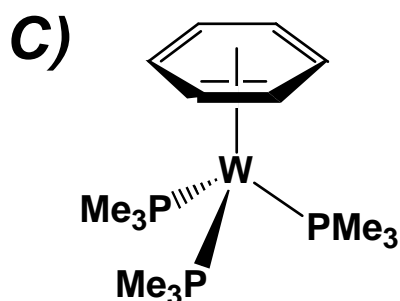
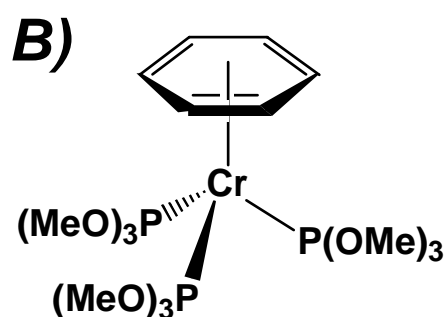
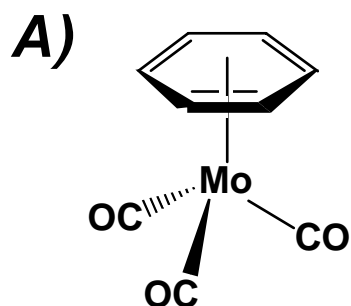

Cyclopentadienyl - Cp

The cyclopentadienyl ligand is one of the most common and popular ligands in organometallic chemistry.

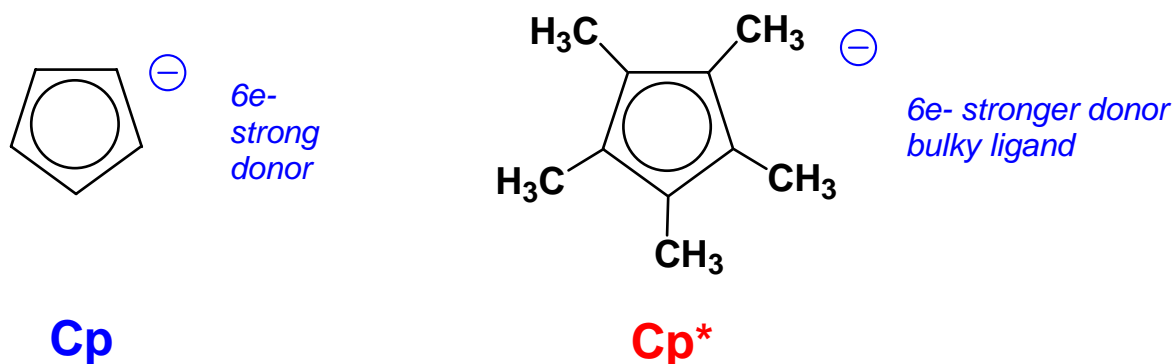

It is an anionic ligand that normally coordinates in an η^5 mode as a 6e- donor, but it can adopt η^3 - and η^1 -coordination modes.

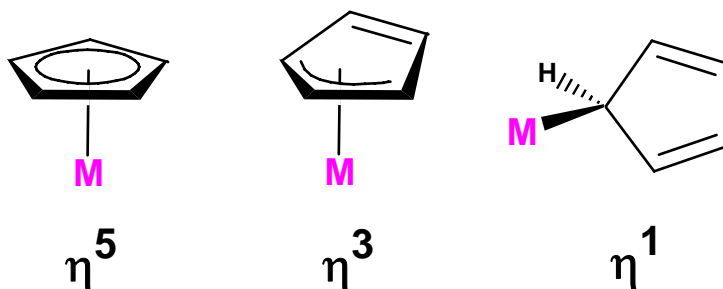

Free neutral cyclopentadiene, which is deprotonated with a strong base to generate the Cp^- , is unstable and reacts with itself via a **Diels-Alder** reaction to make the dicyclopentadiene. One typically regenerates cyclopentadiene by distilling (“cracking”) it from the high boiling dimer solution and storing it in a refrigerator, but it slowly re-dimerizes to make dicyclopentadiene.

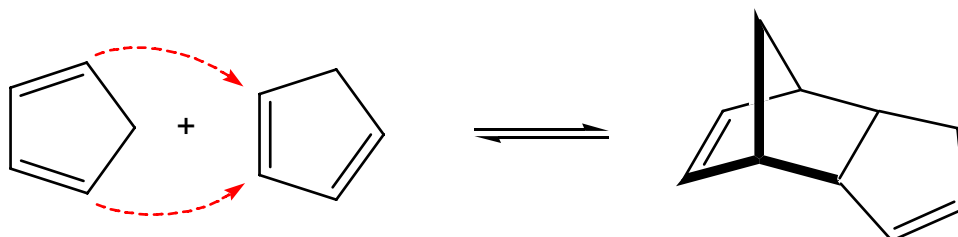

Brief History of Ferrocene:

1901 Synthesis of KC_5H_5 from K and C_5H_6

1951 Miller, Tebboth & Tremaine

Synthesis of $\text{Fe}(\text{C}_5\text{H}_5)_2$ from the reaction of C_5H_6 with freshly reduced Fe at 300°C

1951 Kealy & Pauson

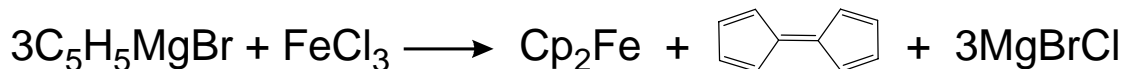

They were trying to make fulvalene!

They proposed that they had made:

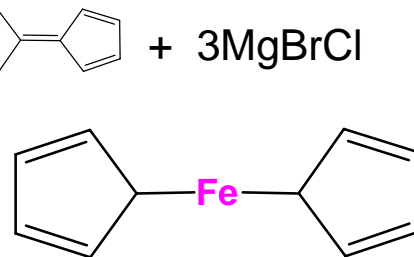

1952 E. O. Fischer proposes a “*Double-cone structure*”

X-ray structural data

Diamagnetism

Chemical behavior

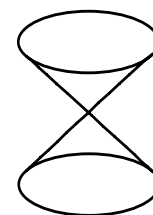

1952 Geoffrey Wilkinson & Robert Woodward: “*Sandwich Structure*”

IR spectroscopy

Diamagnetism

Dipole moment = 0

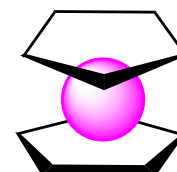

Woodward noted that the Cp rings were susceptible towards electrophilic substitutions, similar to the aromatic behavior of benzene.

Thus the common name: **ferrocene**

1973 Fischer & Wilkinson receive the Nobel Prize in Chemistry for their “discovery” of ferrocene, which played a key role in opening up the new area of organometallic chemistry.

For a short historical account see *Chemical & Engineering News*, Dec 3, 2001 (I have copies of the article) or the special Ferrocene issue of *Journal of Organometallic Chemistry*, Vol 637-639, Issue 1, 3 December 2001.

The structure of ferrocene does have a sandwich structure with a bonding interaction from each ring carbon to the metal, although virtually all researchers only draw a single bond from the metal to the middle of the Cp ring(s) as shown below in the structural diagram.

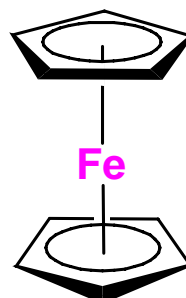
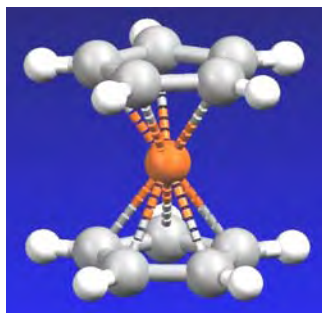

Some Properties of Metallocenes

Complex	Color	mp/°C	Miscellaneous
"Ti(C ₅ H ₅) ₂ "	green	200 (decomp.)	bimetallic with two m-H bridges and a fulvalene bridging ligand (structure shown later)
V(C ₅ H ₅) ₂	purple	167	very air-sensitive, paramagnetic
"Nb(C ₅ H ₅) ₂ "	yellow	-	bimetallic with η ¹ ,η ⁵ -C ₅ H ₄ bridges and terminal hydrides (structure shown later).
Cr(C ₅ H ₅) ₂	scarlet	173	very air-sensitive
"Mo(C ₅ H ₅) ₂ "	Black	-	several bimetallic isomers with fulvalene and h ¹ ,h ⁵ bridges and terminal hydrides (structures shown later), diamagnetic, air-sensitive.
"W(C ₅ H ₅) ₂ "	yellow-green	-	same as Mo
Mn(C ₅ H ₅) ₂	brown	173	air-sensitive and easily hydrolyzed, interesting high-spin to low-spin interconversion
Fe(C ₅ H ₅) ₂	orange	173	air-stable , can be oxidized to blue-green [Fe(C ₅ H ₅) ₂] ⁺ which, in turn, is a good "inert" oxidizing agent.
Co(C ₅ H ₅) ₂	purple-black	174	air-sensitive, paramagnetic 19e- complex, can be oxidized to the air-stable 18e- yellow [Co(C ₅ H ₅) ₂] ⁺
Ni(C ₅ H ₅) ₂	green	173	20e- complex, slow oxidation in air to the labile, orange cation [Ni(C ₅ H ₅) ₂] ⁺

Adapted from Elschenbroich & Salzer, "Organometallics", VCH, 1989

Structural Features

The parallel sandwich structures have the following structural features:

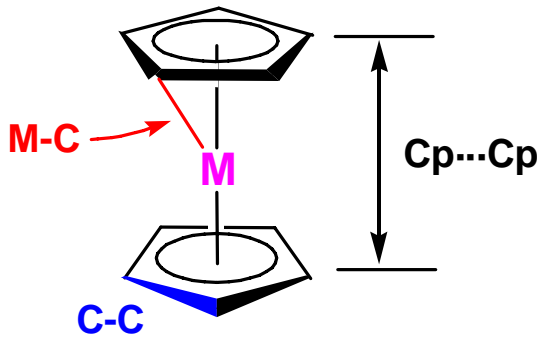

M	Distances (Å)		
	M-C	Cp...Cp	C-C
Fe	2.04	3.29	1.42
[Fe] ⁺	2.07	3.40	1.40
Ru	2.19	3.64	1.43
Os	2.19	3.61	1.45
Co	2.10	3.44	1.41
[Co] ⁺	2.03	3.24	1.42
Ni	2.18	3.63	1.41

Note the various trends in the bond distances. The changes in the neutral Fe, Co, Ni metallocenes are a direct result of going from $18e^-$ (Fe) to $19e^-$ (Co) to $20e^-$ (Ni) counts. The extra electrons for the Co and Ni complexes are going into M-Cp antibonding orbitals, which are delocalized and progressively weaken the M-Cp bonding, leading to the increase in bond distances. This in spite of the fact that the metal's covalent radius is *decreasing* as one goes from Fe \longrightarrow Ni (effective atomic number contraction effect).

Problem: Explain why the Fe-C distance *lengthens* for $[\text{Cp}_2\text{Fe}]^+$, while the Co-C distance *shortens* for $[\text{Cp}_2\text{Co}]^+$.

Oxidation of Cp_2Os does not produce a simple cationic monomer as seen for Co and Fe. Instead one gets dimerization to produce the following bimetallic complex that has an Os-Os bond (3.04 Å).

Problem: Is this complex para- or diamagnetic?

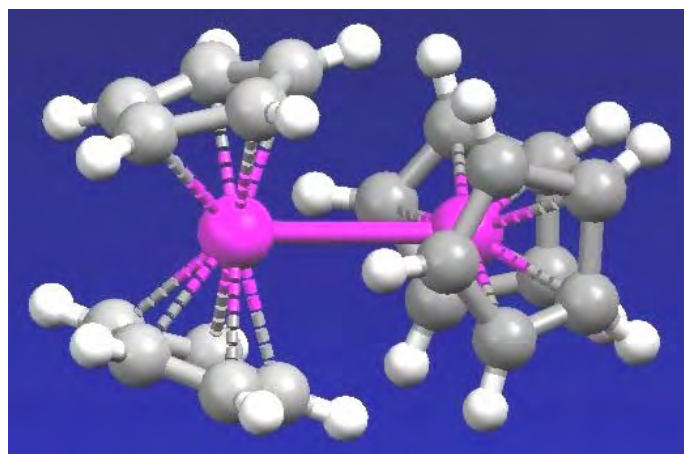

The simple neutral bis-Cp complexes of the **early transition metals** are quite different because they are in very low **+2** oxidation states (very electron-rich) and quite unsaturated. Thus, they are very reactive towards **oxidative addition** and other reactions.

“ $\text{Nb}(\text{C}_5\text{H}_5)_2$ ”, for example, is nominally a 15 e- complex with a highly reactive d^3 Nb electronic configuration.

Two molecules of niobocene react with one another via C-H bond activation (**oxidative addition**) to produce the structure shown to the right. Note that two of the Cp rings are dianionic forming both a traditional anionic η^5 **6e- π -type donor** to one metal, while bridging over and acting as an **anionic 2e- σ -donor** to the other metal center. **Practice your electron counting on this.**

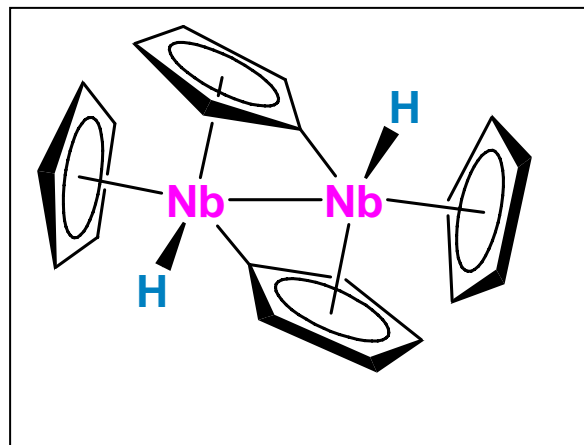

“ $\text{Ti}(\text{C}_5\text{H}_5)_2$ ”, is nominally a 14 e- complex with a highly reactive d^2 electronic configuration. Two molecules of titanocene also react with one another via C-H bond activation (**oxidative addition**) to produce a bimetallic complex that may well look just like the niobium complex just discussed. But it has a further reaction (perhaps due to steric crowding brought on by the smaller Ti centers) leading to the coupling of the two σ -bound Cp's to produce C-C bound bis-Cp and the complex shown below. The more sterically crowded pentamethyl-Cp (Cp^*) complex simply does a **hydride abstraction** and stops at the complex also shown below.

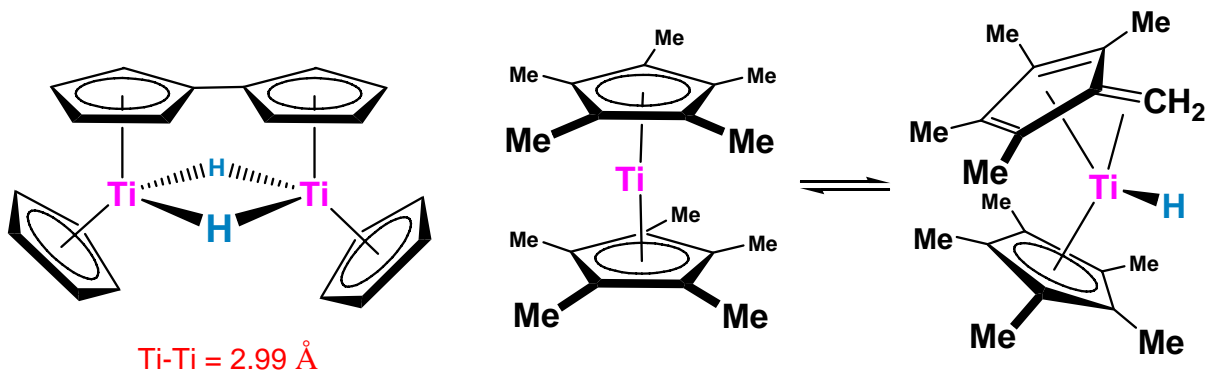

Problem: Electron-count the bimetallic Ti complex to the above left. Should it have a Ti-Ti bond or not? Show your electron counting.

Problem: What advantage does the Cp^*_2Ti complex (above middle) gain by doing a hydride abstraction to produce the hydride complex to the above right (previous page)?

The “ $\text{Mo}(\text{C}_5\text{H}_5)_2$ ” and “ $\text{W}(\text{C}_5\text{H}_5)_2$ ” complexes might appear to have a “reasonable” 16 e- count, but they are quite reactive, like their early transition metal cousins, and also self react with one another via C-H bond activations to produce several isomeric bimetallic complexes shown below.

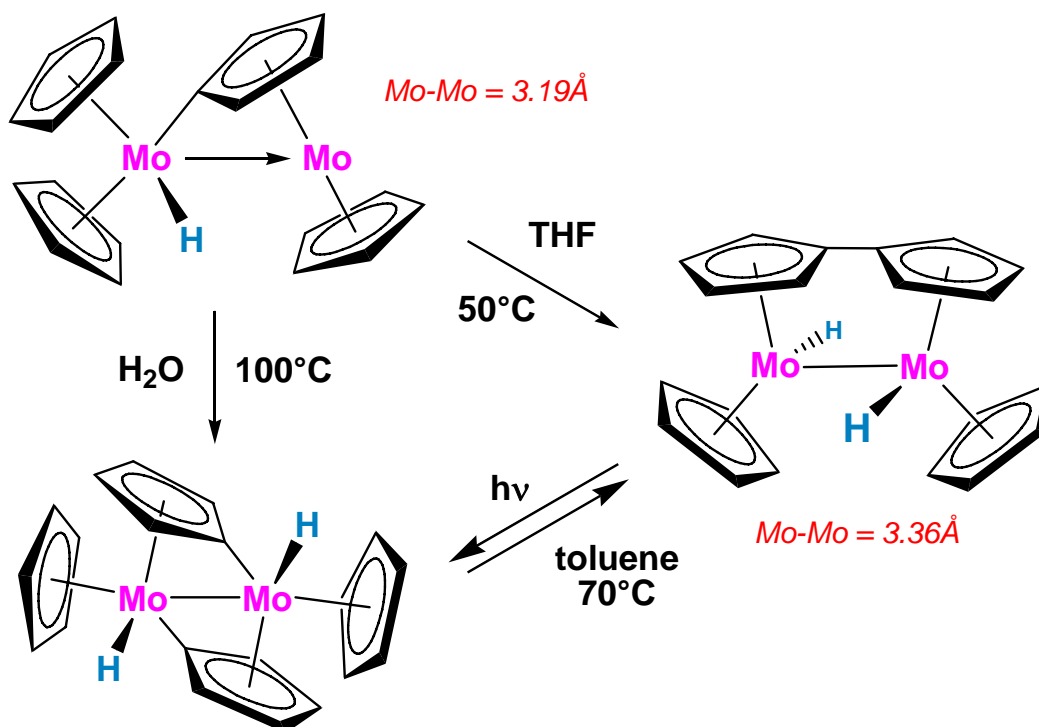

Problem: Electron-count the following complex. What does the arrow between the two Mo atoms indicates? It is NOT a covalent Mo-Mo bond. What name for this type of bonding would you use?

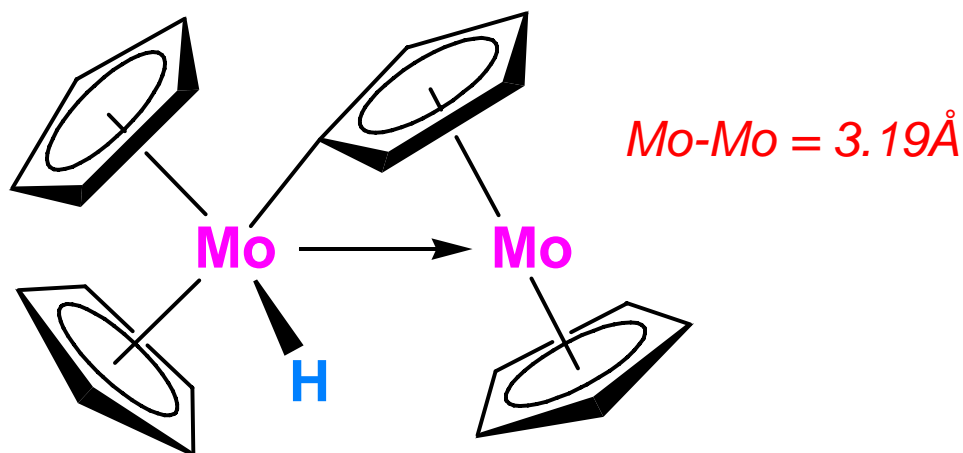

Cp Variants

these have special bonding properties important in substitution reactions (see that chapter)

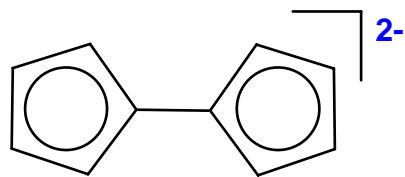

fulvalenediyl (2-)

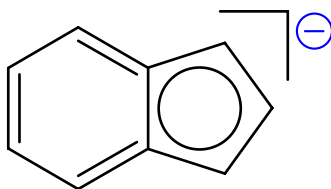

indenyl (-)

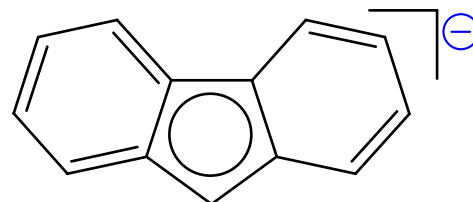

fluorenyl (-)

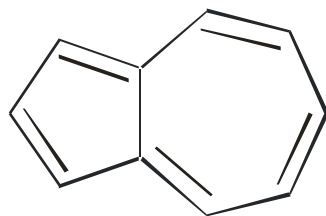

azulene

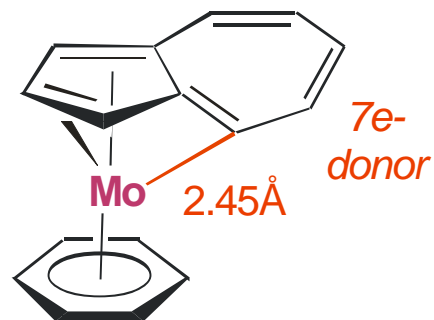
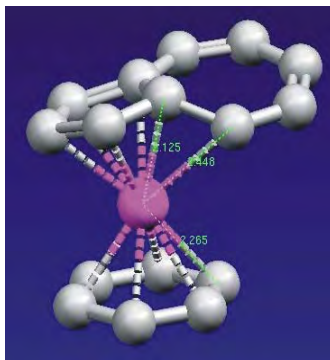

Behrens, *Angew. Chem.*, 1987

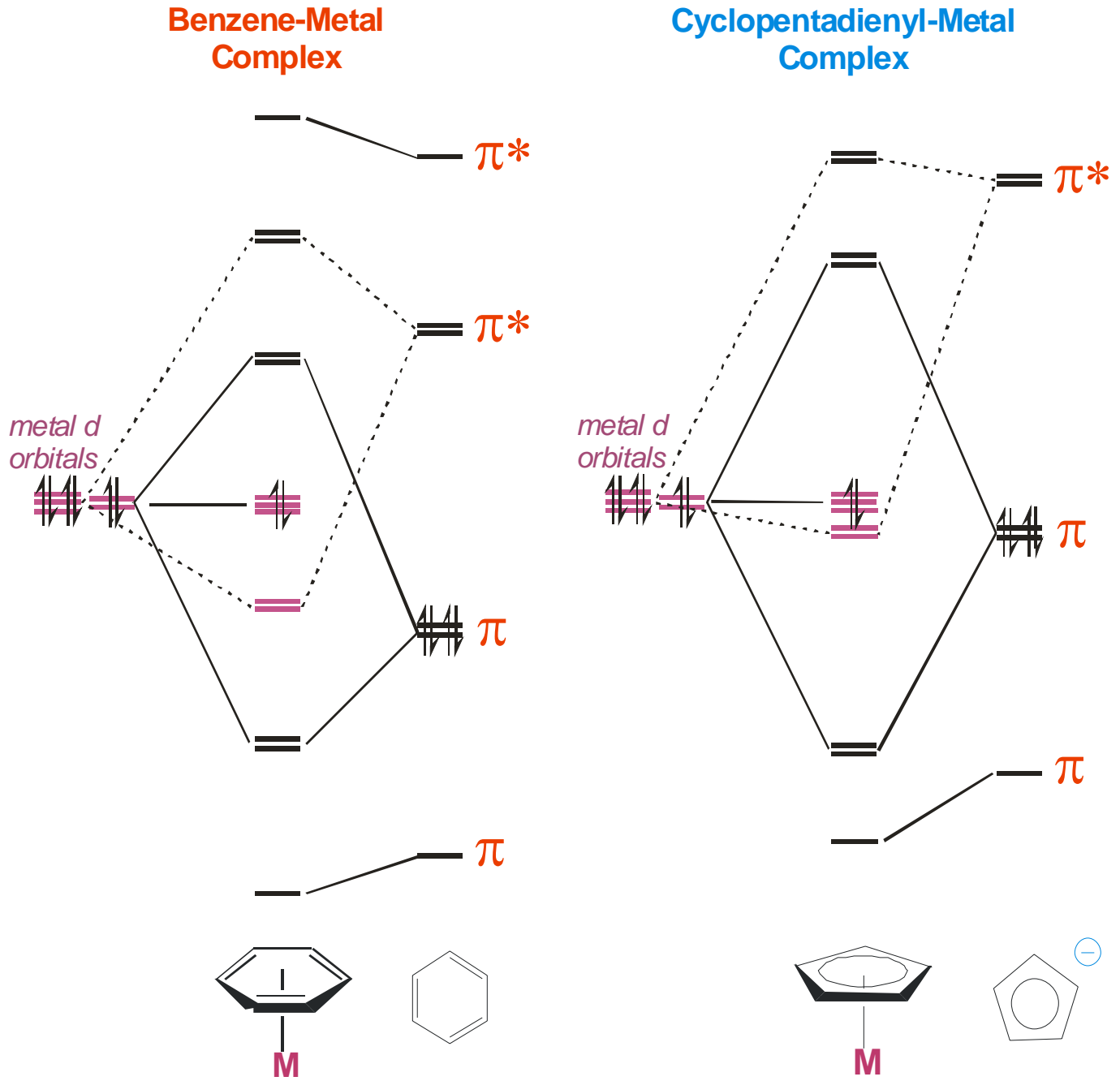
MO Comparison of Cp^- vs. Arene Ligands

Metal-Metal Bonding

There are three general classes of M-M bonding:

- Covalent:** Electron precise bonds. M-M bond counts as one e- from each metal center. Most common type of M-M bonding.
- Dative:** Where one metal uses a filled *d* orbital “lone pair” to coordinate to an empty orbital on a second, more unsaturated metal. Most **dative bonding** situations can also be electron-counted as **covalent bonds**.
- Symmetry:** Weak metal-metal interactions caused by molecular orbital symmetry interactions of filled & empty M-M bonding and/or antibonding orbitals. Typically seen for d^8 metals. Not at all common.

Overlap of *d* orbitals to make different types of **covalent** M-M bonding interactions (strongest to weakest):

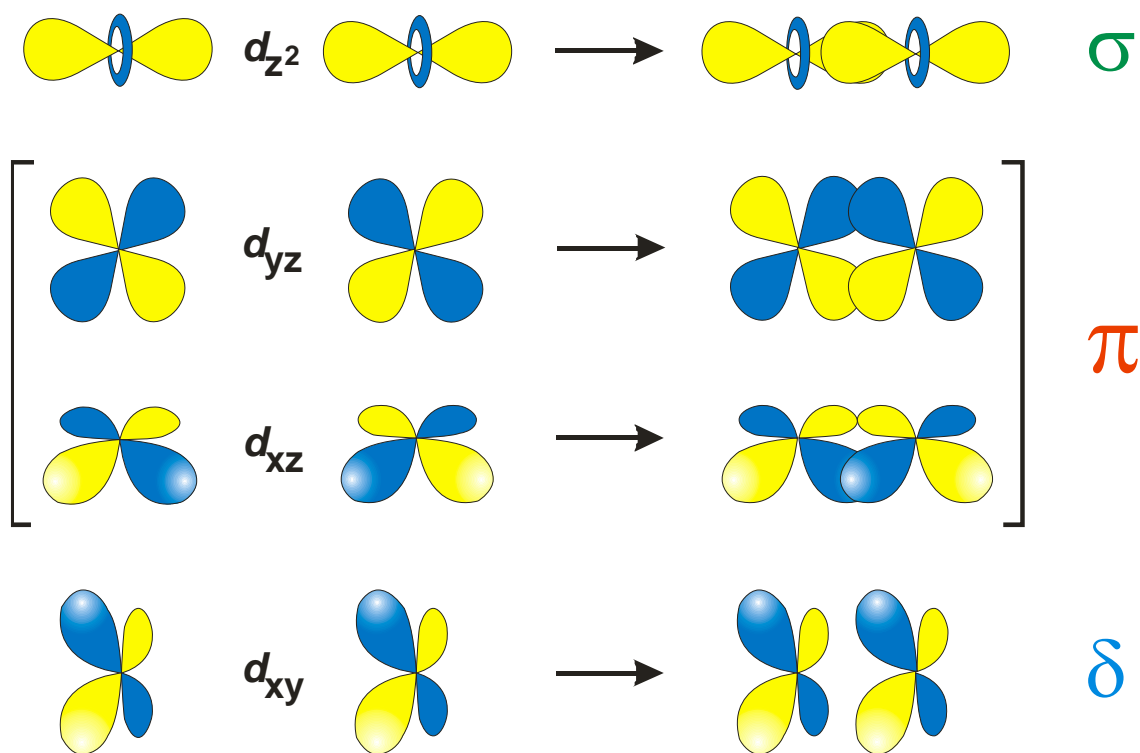

the $d_{x^2-y^2}$ orbitals (not shown) are used for M-L bonding

A qualitative MO diagram for the interaction of two square planar metal centers showing the M-M bond forming interactions:

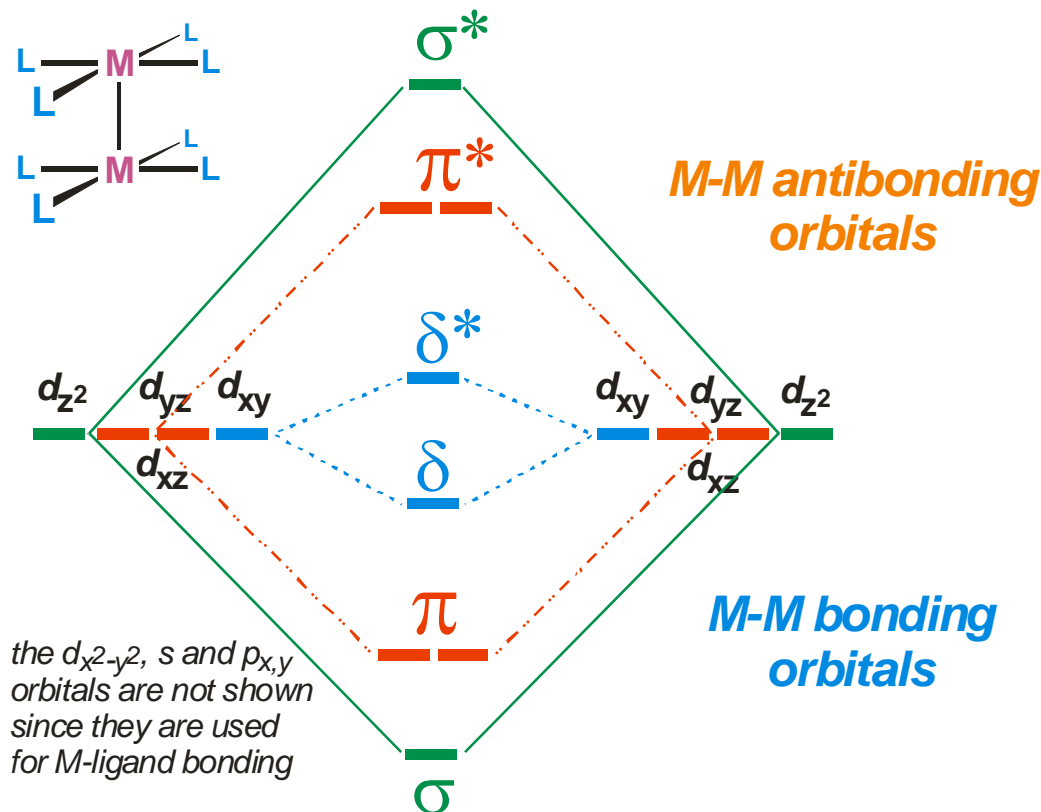

As one fills the lower energy M-M bonding orbitals, one makes one M-M bond for each pair of electrons added (one per metal). But once you add more than 8 e⁻ the antibonding orbitals begin to fill and this starts canceling out M-M bonds.

Electron Count	Resulting M-M Bond
d ¹ - d ¹	Single bond
d ² - d ²	Double bond
d ³ - d ³	Triple bond
d ⁴ - d ⁴	Quadruple bond → optimum
d ⁵ - d ⁵	Triple bond
d ⁶ - d ⁶	Double bond (<i>M-L bonding usually dominates</i>)
d ⁷ - d ⁷	Single bond
d ⁸ - d ⁸	No bond (<i>symmetry interaction</i>)

Note that the table on the previous page specifically refers to two square-planar metals interacting as shown in the MO diagram. Metal centers with other geometries can often adopt M-M bond orders different from that shown in the table. Electron-counting can often provide some guidance on this. **Although, if you don't have any d electrons, you generally can't have any M-M bonding.** Nor can you have a higher M-M bond order than the # of d electrons being shared between the metal centers. For example, two d^2 metals could only form a maximum of a M=M double bond.

Some Covalent Multiple Bonded Examples:

Double Bonds

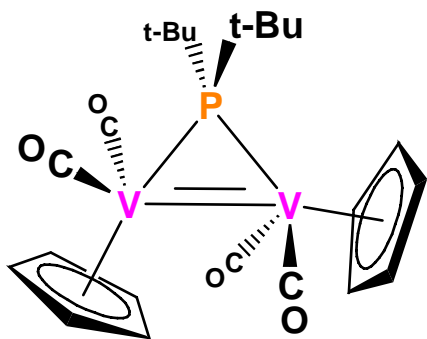

$$V=V = 2.92 \text{ \AA}$$

*an unusual d^8-d^8
double bonded system*

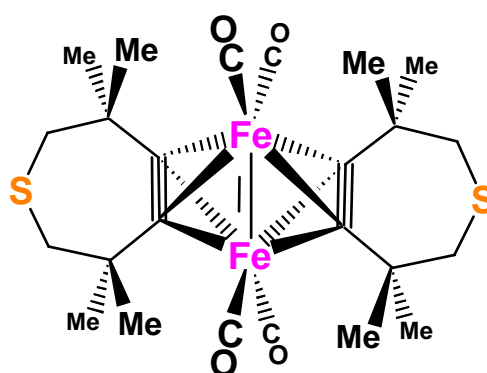

$$Fe=Fe = 2.23 \text{ \AA}$$

Triple Bonds

Chisholm d^3-d^3 Triple Bonds

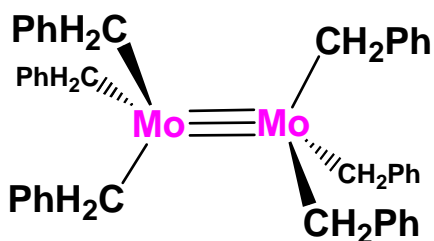

$$Mo-Mo = 2.17 \text{ \AA}$$

d^5-d^5 Triple Bond

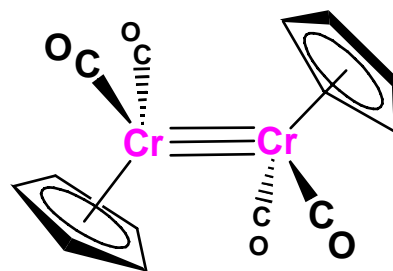

$$Cr-Cr = 2.27 \text{ \AA}$$

Quadruple Bonds (Cotton)

d^4-d^4 electronic configurations often lead to the formation of quadruple M-M bonds. Prof. F. Albert Cotton at Texas A&M is famous for his discovery and extensive studies of M-M quadruple bonds (and other M-M bonded systems).

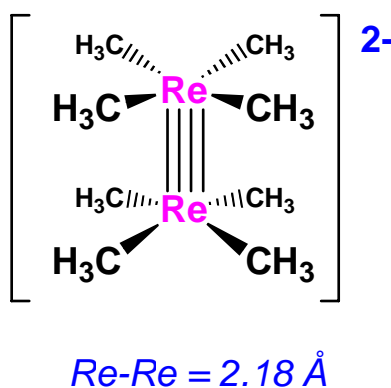
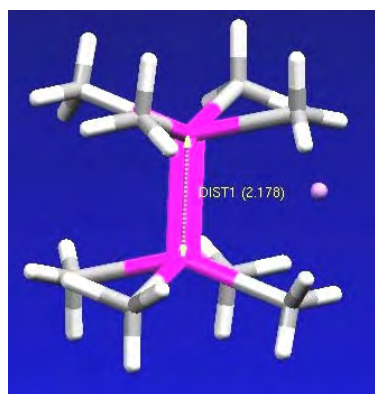
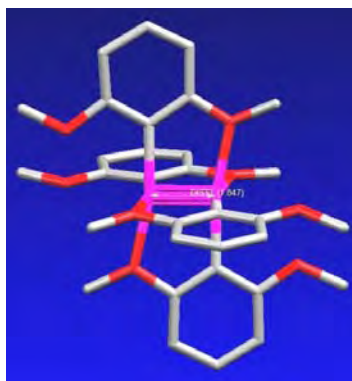
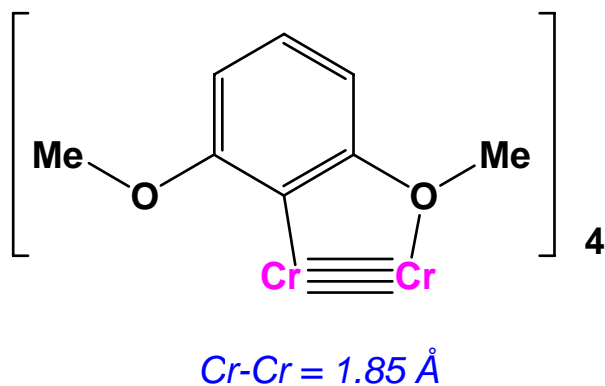

View down Re-Re axis showing eclipsed geometry

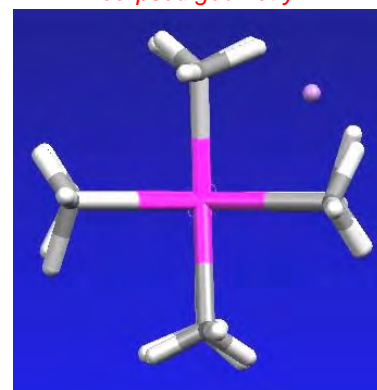

An important orbital feature of quadruple bonds is that they have **eclipsed** D_{4h} -like ligand conformations. This is clearly illustrated above for the non-bridged $[Re_2(CH_3)_8]^{2-}$ complex. There is clear steric repulsion between the methyl groups that could be relieved by rotation to a staggered geometry. But the δ -bond component of the quadruple bond favors an **eclipsed orientation** and imposes a rotational barrier for rotations about the quadruple bond. **Triple bonds** do not have this rotational barrier (free rotation!), thus the $M \equiv M$ triple bonded complexes on the previous page have staggered geometries.

Dative M-M Bonds (unsymmetrical M-M bonded complexes)

When a metal center with at least two d electrons and a moderately high electron count (16 or 18e⁻) is adjacent to a metal that is unsaturated and electron-deficient, the more electron-rich metal center can donate a lone pair of d electrons to the unsaturated metal to form what is called a dative M-M bond. This is usually indicated by using an arrow (\longrightarrow) instead of a line for a covalent bond.

Consider the following bimetallic nickel complex:

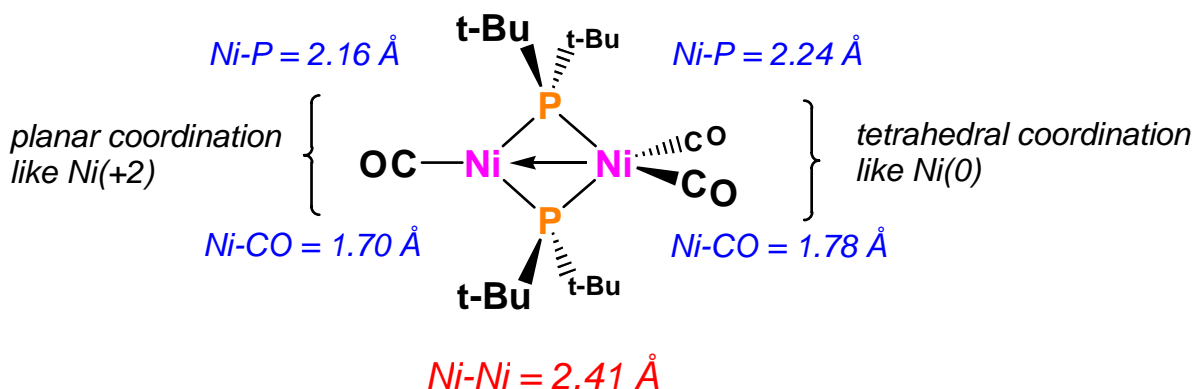

There are two ways of viewing this electronically (see table below) symmetrically dividing the +2 charge on the nickels needed to balance the two anionic phosphide ligands giving you two d^9 Ni(+1) oxidation state metals, a covalent Ni-Ni bond, and 16 and 18e⁻ metal centers.

Covalent M-M Bonding			
Left Ni		Right Ni	
Ni(+1)	d^9	Ni(+1)	d^9
$[\mu-PR_2]^-$	2e ⁻	$[\mu-PR_2]^-$	2e ⁻
$\mu-PR_2$	2e ⁻	$\mu-PR_2$	2e ⁻
CO	2e ⁻	2CO	4e ⁻
M-M	1e ⁻	M-M	1e ⁻
Total	16e⁻	Total	18e⁻

Dative			
Left Ni		Right Ni	
Ni(+2)	d^8	Ni(0)	d^{10}
$2[\mu-PR_2]^-$	4e ⁻	$2\mu-PR_2$	4e ⁻
CO	2e ⁻	2CO	4e ⁻
Ni \leftarrow Ni(0)	2e ⁻		
Total	16e⁻	Total	18e⁻

The other method is to note that the one nickel has tetrahedral coordination geometry, just like a d^{10} Ni(0) center, while the other nickel has a planar geometry similar to a d^8 Ni(+2) center. One can “assign” the two negatively charged phosphide ligands with the Ni(+2) center and have them acting as “neutral” 2e⁻ donors to the Ni(0) center. This then gives one an 18e⁻ Ni(0) center

and a three-coordinate $14e^-$ $\text{Ni}(+2)$ center. Let the electron-rich, $18e^-$ d^{10} $\text{Ni}(0)$ center donate one of its lone pairs to the unsaturated $14e^-$ d^8 $\text{Ni}(+2)$ bringing it up to $16e^-$, which is a normal electron-count for a square-planar d^8 $\text{Ni}(+2)$ atom.

Note that we get the same electron count and some sort of Ni-Ni bond via either method. So you generally don't have to worry about which method you use. Obviously, the covalent method is simpler.

The reason that many consider the dative M-M bond method to be more "accurate" is that if both nickel atoms are classified as $\text{Ni}(+1)$, why don't both have the same geometry? One could explain the differences in geometry & structural features simply because one Ni has an extra CO coordinated and we will have an electronically unsymmetrical complex regardless of the oxidation state assignments.

Problem: Electron-count the following complex using both the covalent and dative M-M bonding methods:

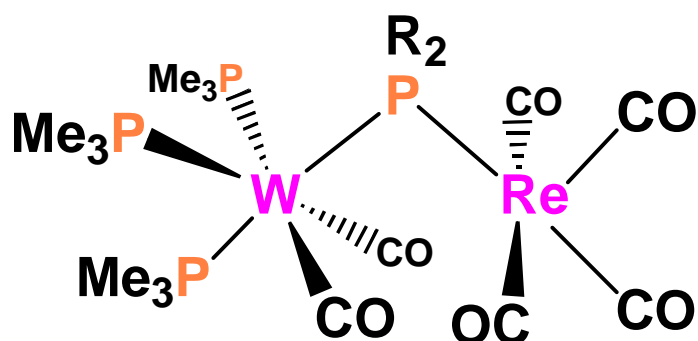

Problem: Electron-count the following complex. What is the order of the Re-Re bond? Why wouldn't it be appropriate to use the dative bond method for this complex?

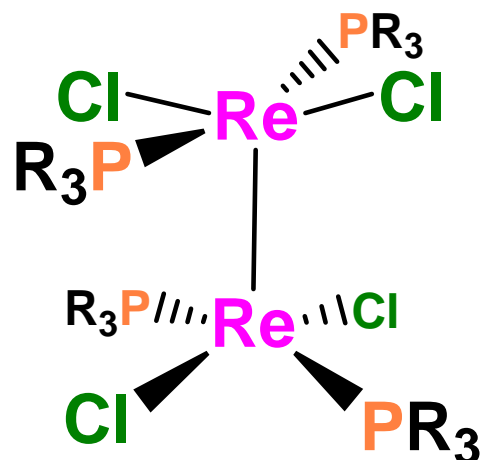

Weak M-M Interactions by Symmetry

Based on the MO diagram at the beginning of this section, d^8-d^8 systems shouldn't have any M-M bonding due to the filling of all the M-M antibonding orbitals, which cancels out the M-M bonding orbitals.

But Harry Gray and others noted that more than a few bi- or polymetallic d^8 complexes do show the presence of weak M-M bonding interactions, both in solution and the solid-state.

For example, the Rh and Ir tetrakis(isocyanide)

complexes, $[M(CNR)_4]^+$, form oligomeric M-M bonded stacks in

solution and in the solid-state, in spite of the fact that there should be no covalent M-M bonds.

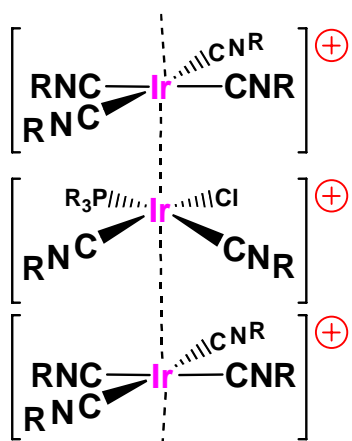

Gray proposed in 1974 that these persistent, but weak M-M interactions were caused by a molecular orbital symmetry interaction between the filled σ -M-M bonding and σ^* -anti-bonding orbitals with the empty p_z σ and σ^* orbitals. The empty orbitals are pushed up in energy and the filled orbitals down in energy by this symmetry

interaction. This generates a weak M-M bond – strong enough, however, to allow these complexes to form M-M bonds even in solution. This orbital effect is shown in the MO diagram to the right.

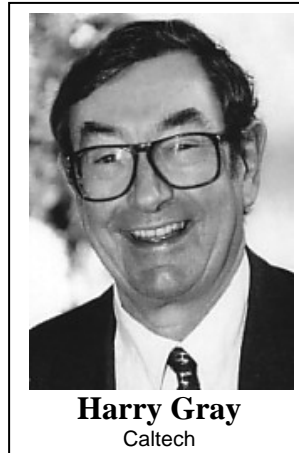
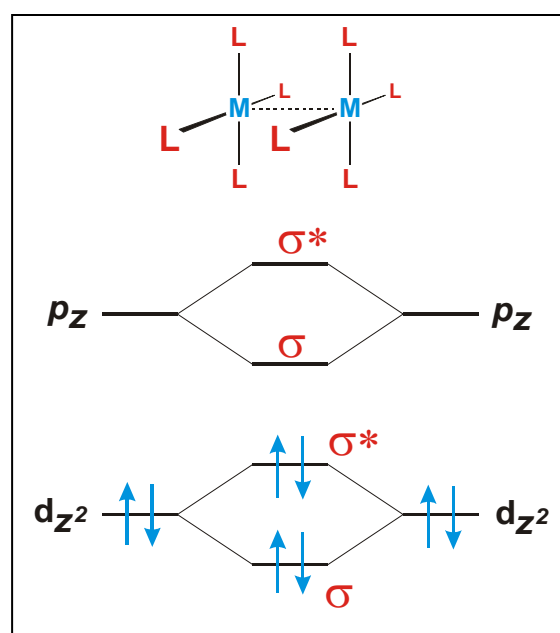

Reaction Mechanisms - Ligand Substitutions

A substitution reaction is one in which an existing ligand on a metal center is replaced by another ligand. Exactly how this occurs depends on the electron count of the metal complex, the existing ligands on the metal, and their steric and electronic properties.



The mechanism of this substitution will almost always depend on whether the parent ML_n complex is coordinatively **saturated** or not!

Cavet: *“A mechanism is a theory deduced from the available experimental data. The experimental results are facts; the mechanism is conjecture based on those facts”*

Lowry & Richardson

“You can never prove that your mechanism is right - only wrong.”

Guy in the audience asking about your proposed mechanism

Substitutions reactions occur by a combination of **ligand addition** and **ligand dissociation** reactions.

Saturated Complex:

Dissociative Pathway!

Unsaturated Complex:

Associative Pathway (usually)

Dissociative pathway (sometimes)

Most of the substitutions we will study will involve $2e^-$ pathways. Odd e^- or radical pathways are known, but less common.

Ligand Addition (association): this is when an incoming ligand coordinates to a metal center that has one or more empty orbitals available.

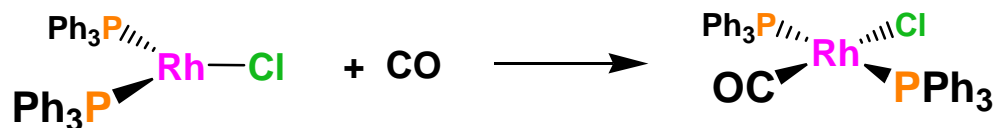

This Rh(+1) complex is d^8 and only 14e⁻. Adding a ligand takes one to the more stable 16e⁻ square-planar complex.

Ligand Dissociation: this is when a ligand coordinated to a metal dissociates (falls off). The probability of a specific ligand dissociating depends on how strongly or weakly it is coordinated to the metal center and steric effects.

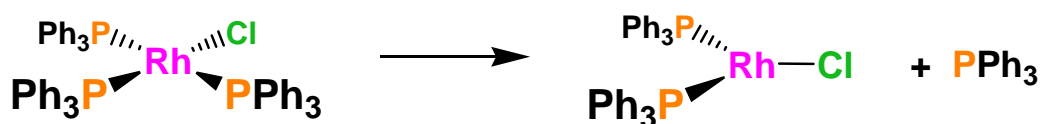

The steric hindrance of the three bulky PPh₃ ligands favors dissociation of one to form the 14e⁻ RhCl(PPh₃)₂ complex. The moderate electron-donating ability of the PPh₃ ligand (not a strongly coordinating ligand) makes this fairly facile.

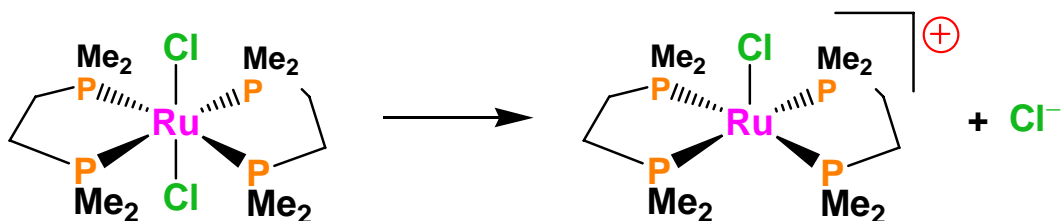

The strongly donating ability of the dmpe ligands combined with their strong chelate effect makes it difficult to dissociate one of the PMe₂ arms. In this case the Cl⁻ anion is the one that dissociates, leaving a cationic complex behind. The two dmpe ligands donate enough electron-density to the Ru center to make it reasonable to dissociate a Cl⁻.

A **ligand substitution** can occur either by an *associative* or *dissociative* route. The exact mechanism depends in large part on the electron-count of the metal complex undergoing the ligand substitution. The simplest case is when one is dealing with an **18e⁻ metal complex**. In this case one almost always has a *dissociative substitution*. In a dissociative substitution, one of the existing ligands on the metal center

has to fall off (**ligand dissociation**), this opens up a free coordination site (**16e⁻**, if one started from an 18e⁻ complex) to which the new ligand can coordinate.

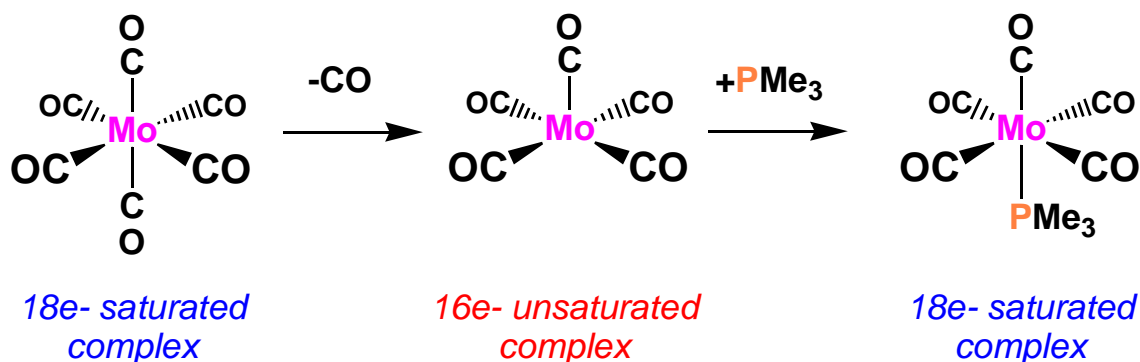

18e⁻ complexes almost always do ligand substitutions through initial ligand dissociation. **Dissociative substitution** can also occur in 16e⁻ (or in very unusual cases, lower electron count systems) complexes. These cases either involve **sterically bulky ligands** that block the open coordination site, or third row square planar d⁸ complex like Pt(+2) where there are strong electronic factors that limit the coordination of an additional ligand to the empty axial site.

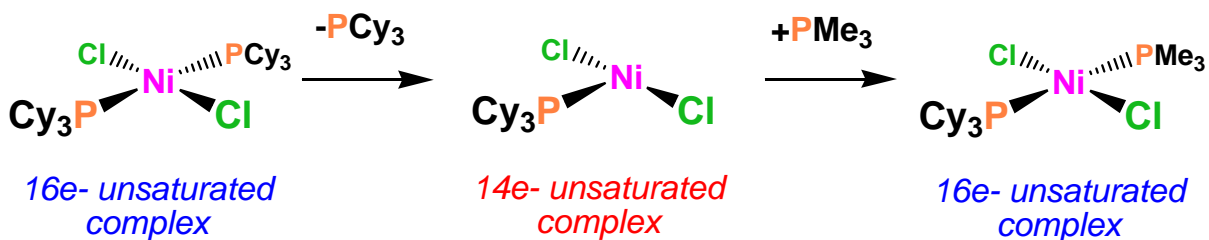

The large PCy₃ ligands sterically block access to the empty axial p_z orbital

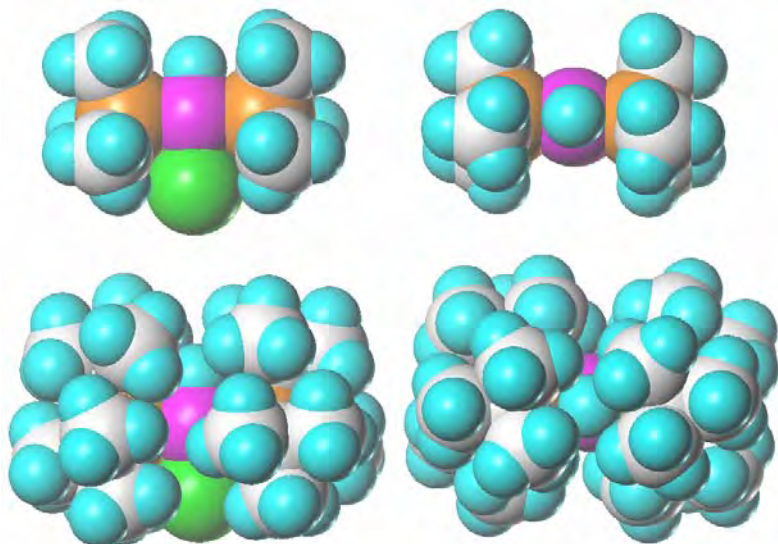

Shown to the left are perpendicular views of space filling models (showing the sizes of the atoms) of HRhCl(PMe₃)₂ (top) and HRhCl[P(t-Bu)₃]₂ (bottom). Color coding: Rh – purple, Cl – green, P – orange, C – white, H – cyan. Note how the much bulkier tert-butyl groups on the phosphines effectively block out the empty axial orbital on the metal (purple atom). In order to do a ligand substitution the HRhCl[P(t-Bu)₃]₂ complex needs to dissociate one of the other ligands first – probably either the P(t-butyl)₃ or the chloride.

In the following example, the filled and spatially extended Pt d_{z^2} orbital can act as an electronic block:

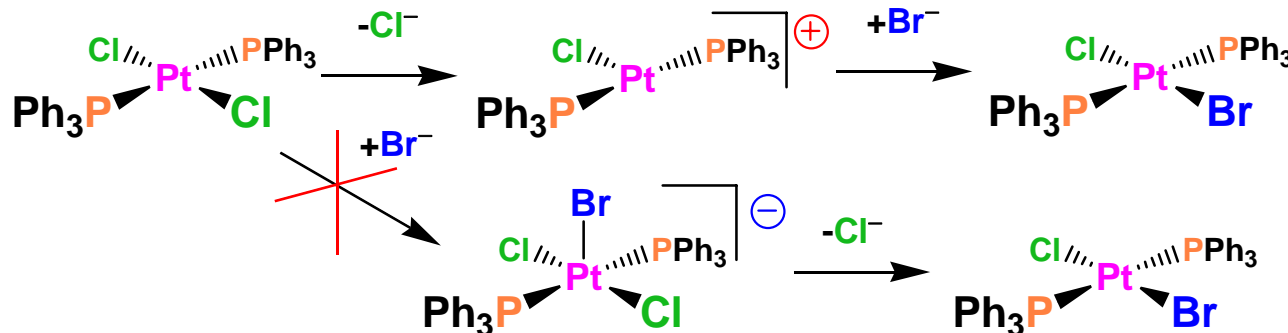

The spatially extended filled axial Pt d_{z^2} orbital partially blocks coordination of ligands via the empty axial p_z orbital. This limits ligand association, although they can occur.

Problem: The rate of substitution reactions on square planar d^8 complexes goes in the order: $\text{Ni} > \text{Pd} \gg \text{Pt}$. Explain why.

Steric Factors

Bulky (large) ligands occupy more space around a metal center and can block incoming ligands trying to access vacant coordination sites on a metal. Due to steric hindrance, however, they are also more often to dissociate to relieve the steric strain. Consider, for example, the following equilibrium:



Ligand:	$\text{P}(\text{OEt})_3$	$\text{P}(\text{O-}i\text{p-tolyl})_3$	$\text{P}(\text{O-}i\text{Pr})_3$	$\text{P}(\text{O-}o\text{-tolyl})_3$	PPh_3
Cone angle:	109°	128°	130°	141°	145°
K_D :	$< 10^{-10}$	6×10^{-10}	2.7×10^{-5}	4×10^{-2}	> 1000

Note that there is virtually no $\text{Ni}(\text{PPh}_3)_4$ in solution. There is too much steric hindrance with the bulky PPh_3 ligands. Note that steric effects often turn on very suddenly – that is, you don't see much effect and then wammo!

Problem: There is also an electronic effect in the previous example that favors PPh_3 dissociation. What is it?

Solvent Effects

Consider the following dissociative substitution rxn discussed earlier:

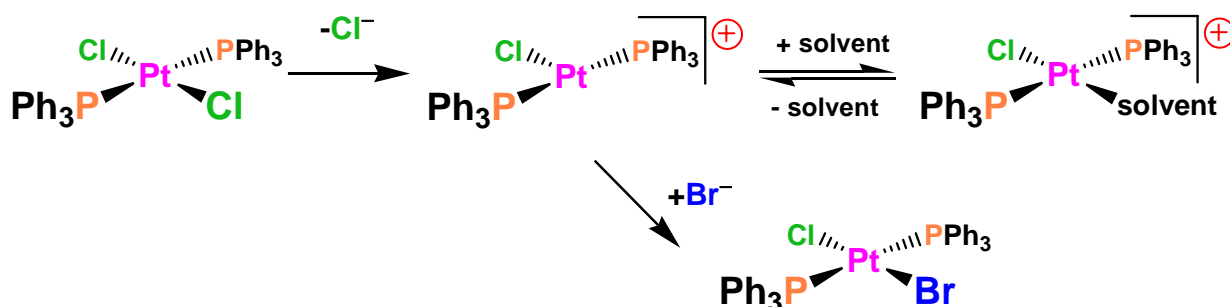

The 14e⁻ three coordinate intermediate is actually almost immediately coordinated by a **solvent** molecule to produce the **solvated** 16e⁻ complex shown to the far right. The solvent is usually weakly coordinated and readily dissociates to constantly produce the 14e⁻ reactive intermediate.

Few organometallic chemists formally write solvated metal complexes down in their mechanisms, but they certainly are formed.

The coordinating ability of the solvent, therefore, can often affect reactions. The presence of lone pairs and electron-rich donor atoms on the solvent usually makes it a better ligand. Some common coordinating solvents are shown on the next page.

The polarity of the solvent can also have a definite impact on a reaction. Polar solvents are usually quite good for reactions, such as that shown above, involving charged species. A non-polar hydrocarbon solvent (like toluene, for example) would probably inhibit the chloride dissociation mechanism. Instead, the dissociation of the neutral, less polar phosphine ligand would probably be favored.

Some Common Coordinating Solvents

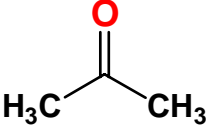
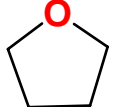
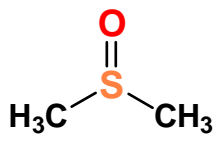
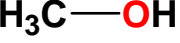
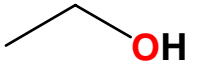
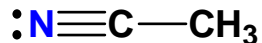
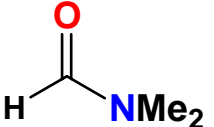
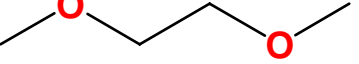
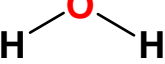
 <p>acetone</p>	 <p>THF (tetrahydrofuran)</p>	 <p>DMSO (dimethylsulfoxide) bp = 189°C mp = 18°C</p>
 <p>methanol</p>	 <p>ethanol</p>	 <p>acetonitrile</p>
 <p>DMF (dimethylformamide) bp = 153°C mp = -61°C</p>	 <p>DME (dimethoxyethane)</p>	 <p>water (rarely used)</p>

Note that one often avoids oxygen containing solvents due to the reactivity of early transition metals towards them. Water is rarely used in organometallic chemistry since many of the reactive metal-alkyl complexes are basic enough and will readily react with water.

Non-coordinating solvents are a misnomer since anything can coordinate to a metal center that is unsaturated and electron-deficient enough. But saturated hydrocarbons like hexane are classic “non-coordinating” solvents. Arene solvents can coordinate via their π -systems, but usually not too strongly.

A common less coordinating, but polar solvent, is CH_2Cl_2 , which is one of the less reactive chlorocarbon solvents. Chlorobenzene is another relatively non-reactive, but somewhat polar solvent.

Trans Effect

The *trans effect* concerns the electronic effect of one ligand on another ligand when they are *trans* to one another. The classical *trans effect* involves two σ -donating ligands *trans* to one another. The stronger σ -donor ligand preferentially weakens the bond of the weaker σ -donor ligand *trans* to it, making it easier to dissociate and do a ligand substitution reaction.

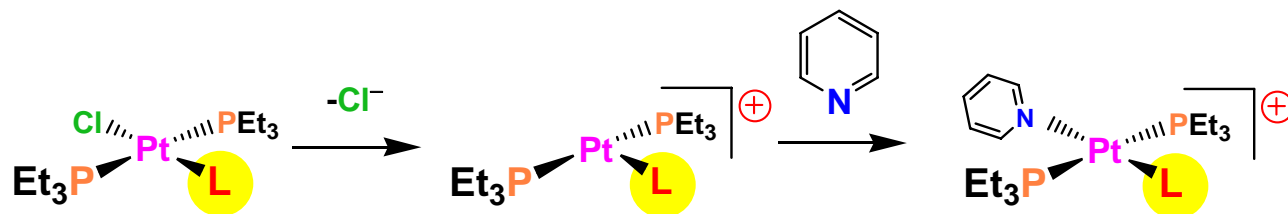

Relative rate of substitution based on *trans* ligand \bullet :
 $\text{Cl}^- = 1$, $\text{Ph}^- = 100$, $\text{CH}_3^- = 10^3$, $\text{H}^- = 10^4$

There is a *cis* effect, but it is much weaker and basically ignored:

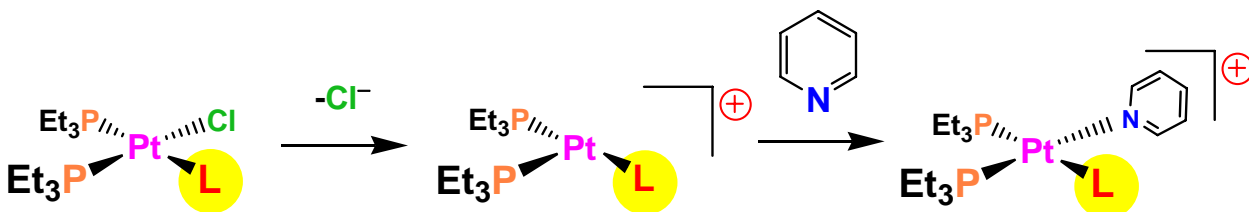

Relative rate of substitution based on *cis* ligand \bullet :
 $\text{Cl}^- = 1$, $\text{Ph}^- = 2$, $\text{CH}_3^- = 4$, $\text{H}^- = 4$

Note that when most chemists talk about the *trans effect* they are referring to the σ - σ type of *trans effect*, where a strong σ -donor weakens the σ -donating ligand *trans* to it.

Do NOT overestimate the importance of the *trans*-effect. As you will see on the following pages there are other forms that have different effects.

π -Acceptor *Trans* Effects

But there are other types of electronic *trans* effects that involve π -backbonding ligands. We will focus here on CO ligands as the most common type.

The bonding of a π -backbonding ligand to a metal with two or more d electrons is *weakened* when there is a *trans* π -backbonding ligand. The competition of both π -backbonding ligands for the same d orbital electrons **reduces** the amount of π -backbonding that can occur and, therefore, *weakens* the M-CO bond strength.

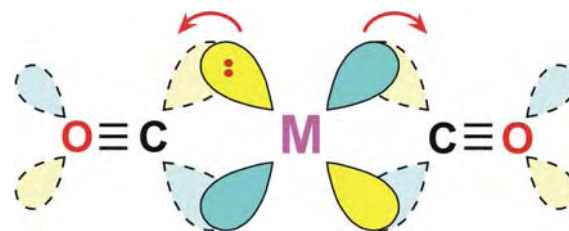

Conversely, a π -backbonding ligand bonding to a metal is *strengthened* by being *trans* to a good σ -donating ligand that can't π -backbond.

Compare the CO infrared stretching frequencies for the following two complexes:

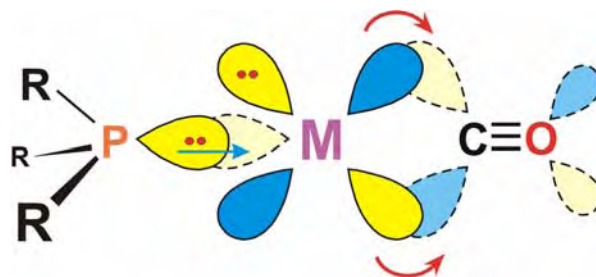

Complex	$\nu_{\text{CO}} \text{ cm}^{-1}$
$\text{Mo}(\text{CO})_3[\text{P}(\text{OMe})_3]_3$	1977, 1888
$\text{Mo}(\text{CO})_3(\text{pyridine})_3$	1888, 1746

The $\text{P}(\text{OMe})_3$ ligand has about the same σ -donor ability as pyridine, but is a considerably better π -acceptor ligand, thus competing with the *trans* CO

ligands more than the pyridine ligands.

There is a further strengthening of M-CO π -backbonding when the *trans* ligand has π -donation properties that can push up the energy of the filled d orbitals and, in turn, make them better π -donors to the CO. This can occur even when the ligand is not an especially strong donor.

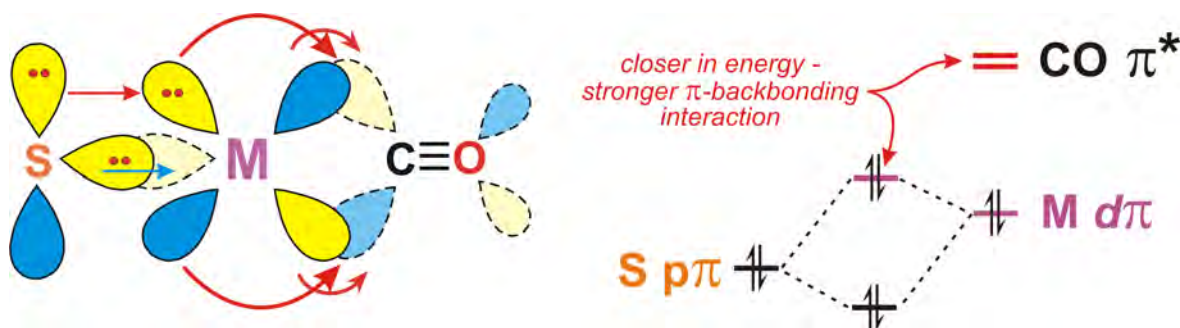

An example of this can be seen in the following three complexes and their “*anomalous*” ν_{CO} stretching frequencies:

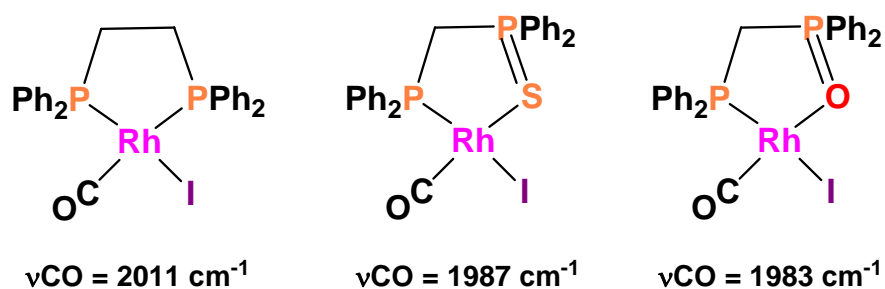

Even though the *trans* PPh₂ is a better σ -donor than the P=S, or certainly the P=O ligand, the “ π -pushing” effect mentioned above enhances the *trans* CO π -backbonding for the P=S and P=O ligands.

Problem: Consider the following series of substitution reactions.

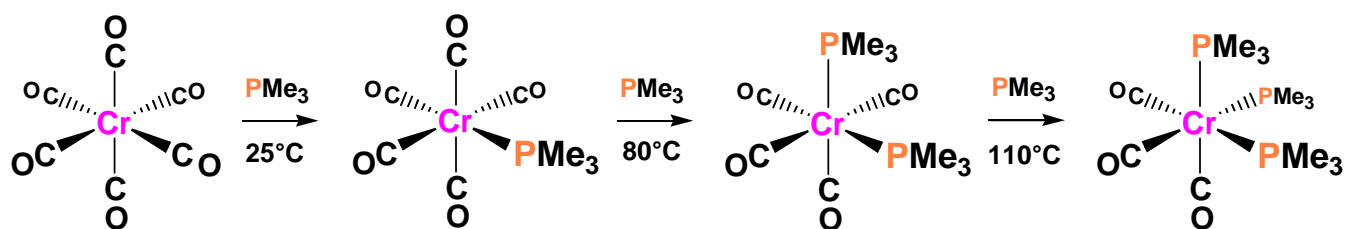

As one replaces each CO ligand with a PMe₃, the next CO substitution is progressively more and more difficult requiring higher temperatures and longer times. Once one forms Cr(CO)₃(PMe₃)₃, it is extremely difficult to replace another carbonyl ligand. Why?

Associative Substitutions

These occur first by a **ligand addition** to the metal complex followed by the **dissociation** of one of the original ligands. You typically need to have an **unsaturated** (17e⁻ or lower) **complex** in order to propose an associative substitution mechanism.

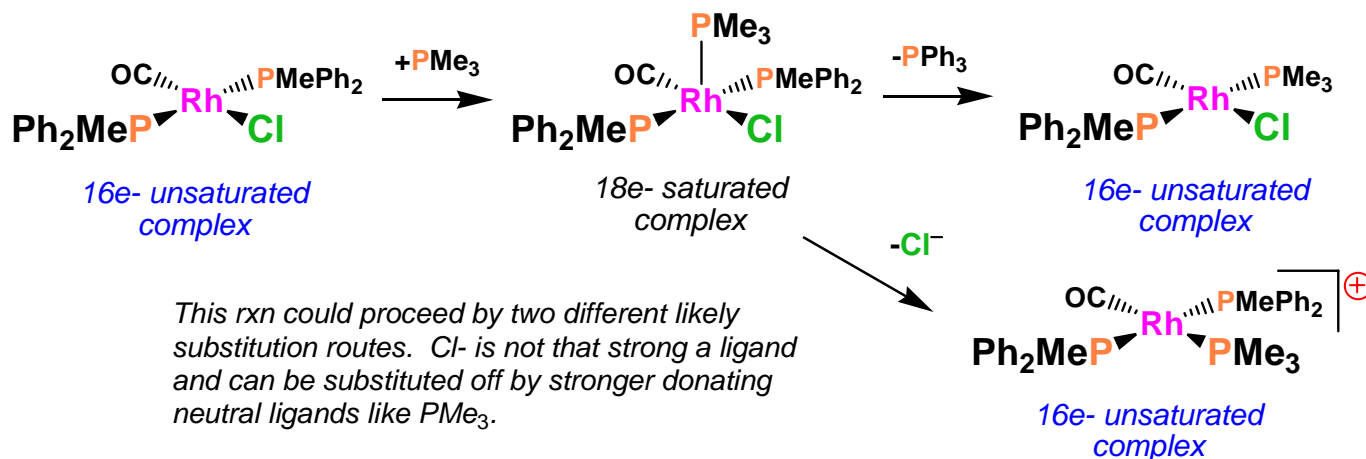

The filled axial Pt d_{z²} orbital partially blocks coordination of ligands via the empty axial p_z orbital. This limits, but does not stop ligand association, which is quite common for Rh(I) and Pd(II).

Although one could theoretically have a ligand addition to an 18e⁻ complex to form a 20e⁻ transition state (or intermediate) that would then dissociate a ligand to reform an 18e⁻ system, there are very few verified examples of this in the literature.

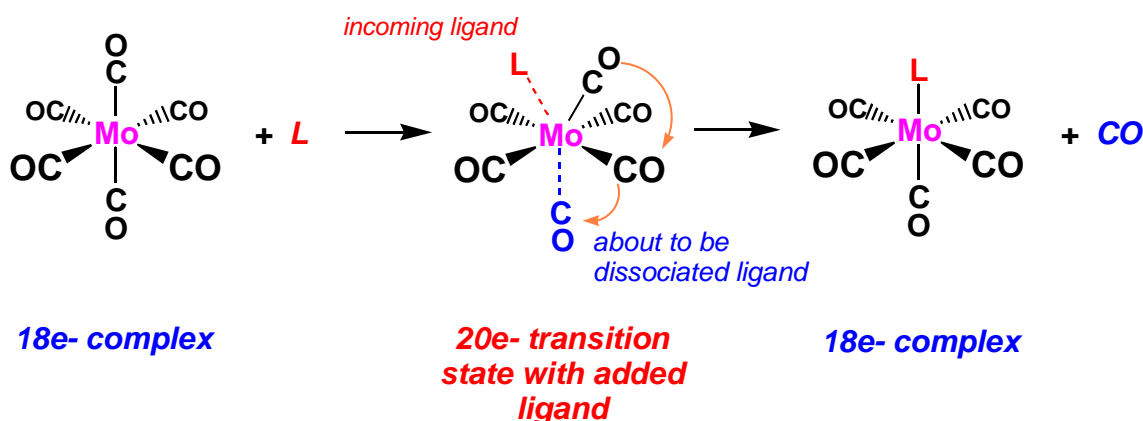

So **associative substitutions** are generally limited to 17e⁻ and lower electron-count systems where the incoming ligand is not **sterically** or **electronically** blocked from bonding (coordinating) to the metal center.

“AC/DC” Ligands

Multidentate ligands (those donate more than 2e⁻ and occupy more than one coordination site on a metal) can often change their coordination number to donate fewer electrons, thus opening up a coordination site that can allow an associative substitution (or just ligand addition).

The Cp ligand can do this by shifting from an η^5 to η^3 (or even η^1) coordination mode as shown in the example below:

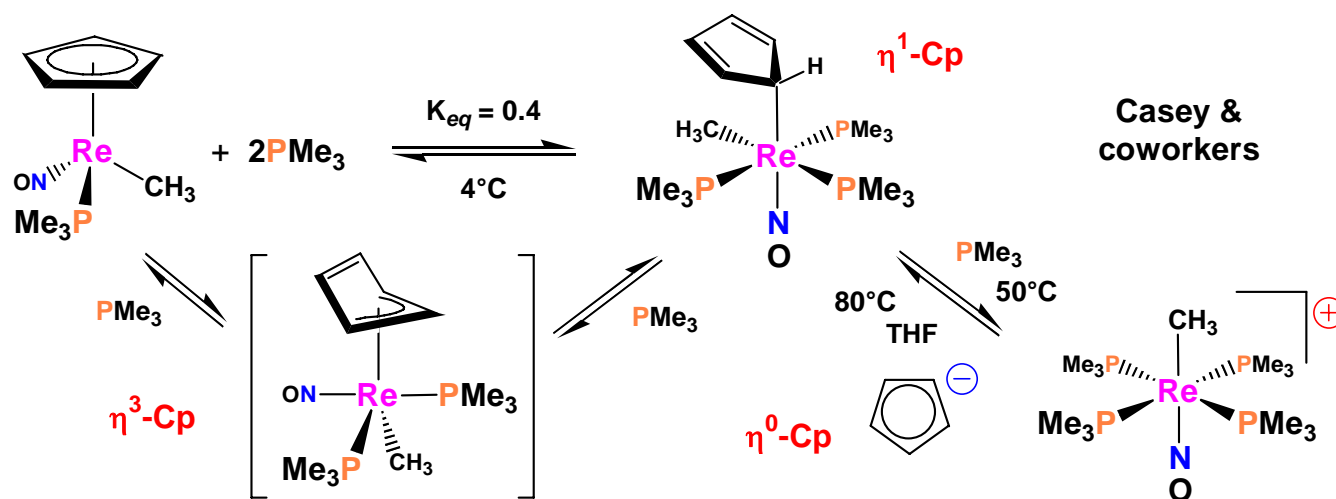

But shifting the η^5 -Cp to the η^3 -Cp coordination mode incurs a moderately high energy cost due to the loss of aromaticity in the Cp ring. So this is not that common.

Indenyl Effect

The indenyl ligand family, however, shows dramatically enhanced substitution reactions due to the ability to switch the aromaticity between the Cp and arene ring via the following resonance structures:

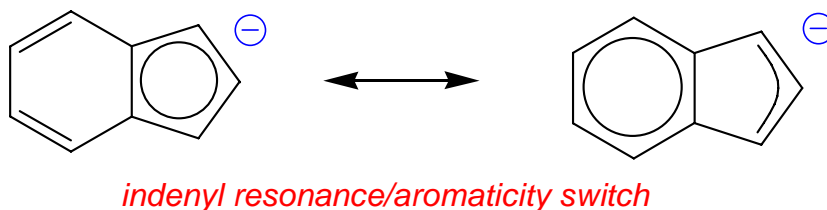

This dramatically lowers the barrier for the η^5 -Cp to η^3 -Cp resonance structure, opening up a free coordination site and allowing far easier ligand additions and substitution reactions.

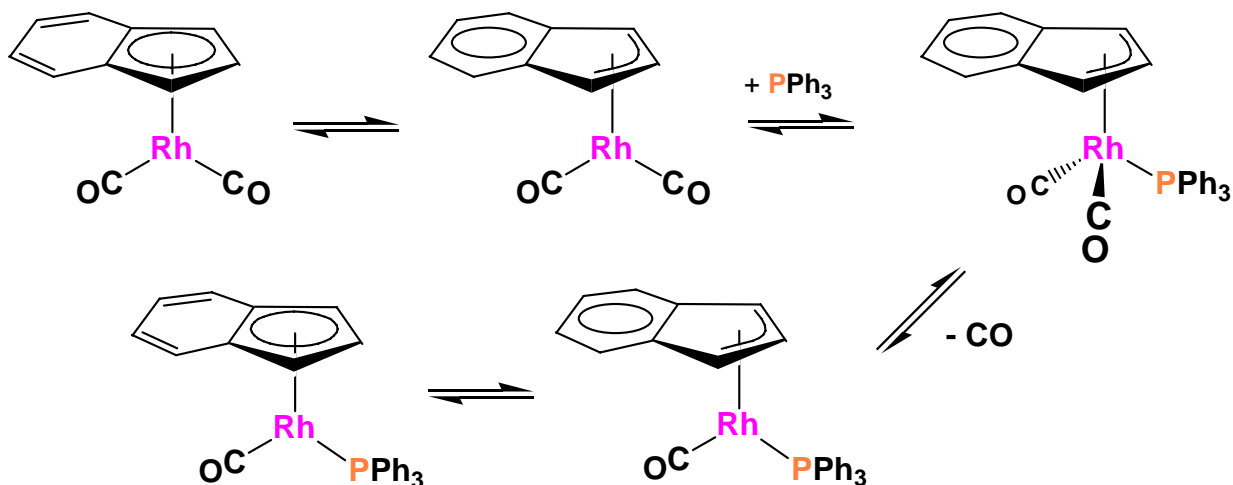

Consider the following relative rates of ligand substitution using the following Cp-class ligands:

Ligand:					
Relative rate of substitution:	$> 10^{10}$	3.8×10^8	6.1×10^5	1	2.2×10^{-2}

The fluorenyl ligand accelerates the ligand substitution reaction by a factor of over 10^{10} !! Holy Cow!

Although the indenyl effect should theoretically generate great catalysts due to the ability to readily open up free coordination sites on the metal, it also, unfortunately, makes the indenyl ligand considerably easier to substitute off the metal completely.

Pentadienyl

The pentadienyl ligand is an acyclic version of Cp that does not have any aromatic stabilization. This has two important effects:

- 1) No aromatic stabilization means that the π -orbitals are higher in energy and are, therefore, better donors than Cp^- . Similarly, the π^* -antibonding orbitals are lower in energy and are better π -acceptors than Cp^- (but the low electronegativity limits the amount of π -backbonding that can occur).
- 2) The lack of aromatic stabilization means that there is a much smaller barrier for η^5 -pentadienyl \rightleftharpoons η^3 -pentadienyl \rightleftharpoons η^1 -pentadienyl transformations.

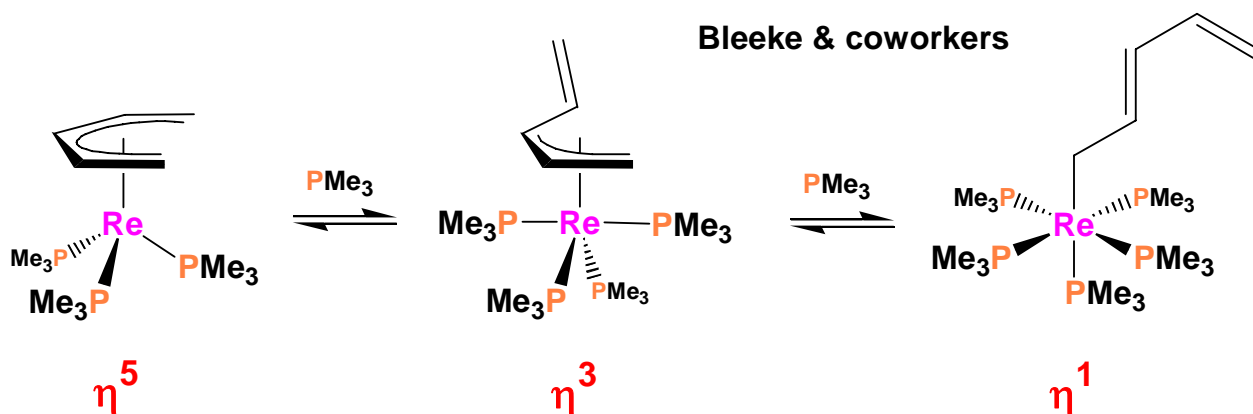

Allyl

The allyl anion has a similar facile ability to switch between η^3 and η^1 coordination modes that can promote ligand additions and/or substitutions.

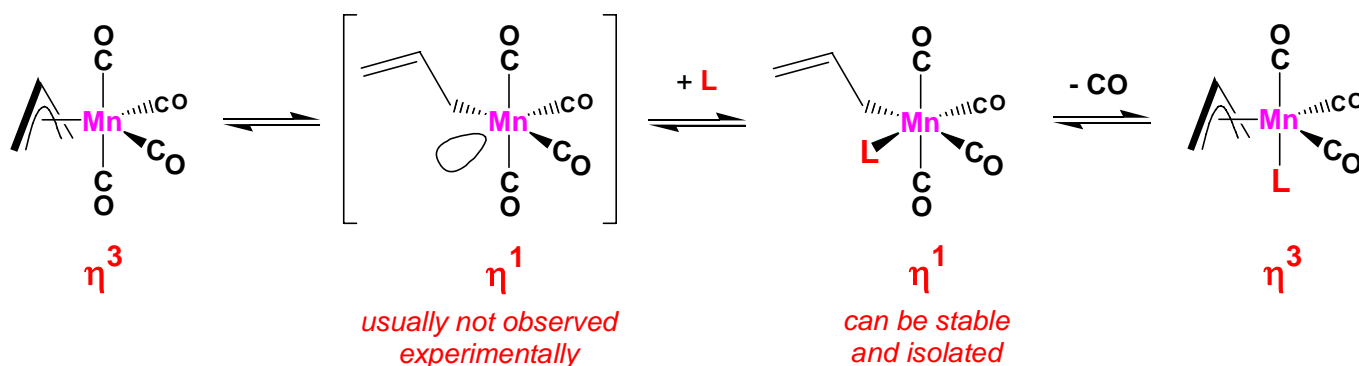

Nitrosyl

We usually count the nitrosyl ligand as a **cationic 2e- donor**, isoelectronic with CO. But it can adopt an **anionic 2e-** configuration with a **bent coordination geometry**:

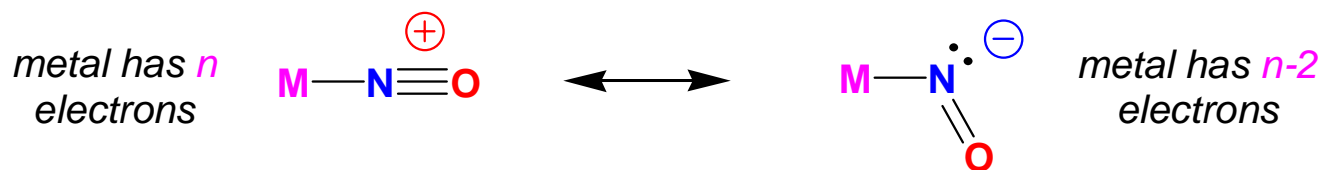

This can occasionally lead to interesting behavior where the linear to bent, cationic to anionic electronic state can open up a coordination site on the metal by essentially oxidizing it (shuttling 2e- from the metal to the NO^+ turning it into NO^-). Given the extremely strong π -**backbonding** ability of NO^+ , this isn't particularly surprising. The linear NO^+ form can usually be easily differentiated from the bent anionic form by IR spectroscopy because of the large change in NO bond order (triple to double bond).

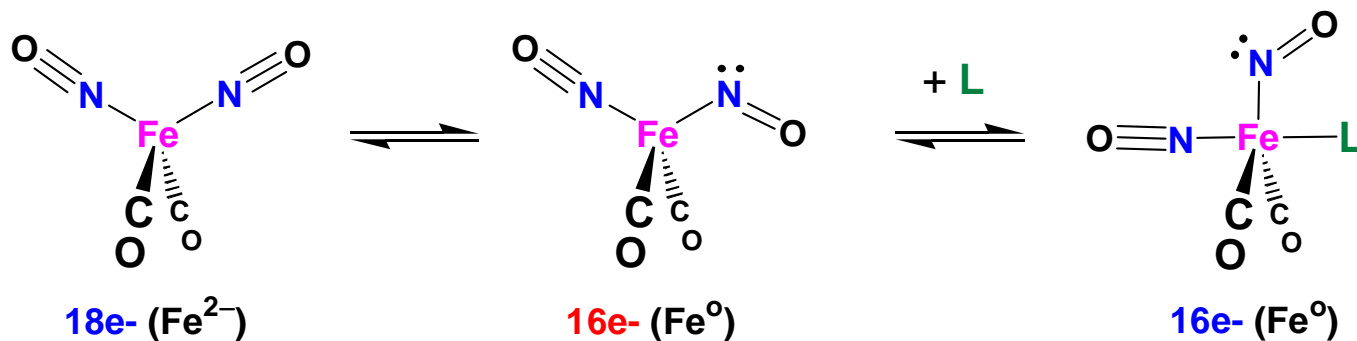

Radical Odd Electron Systems

17e-

One typically sees fairly dramatic rate enhancements for ligand substitution reactions of 10^3 to 10^7 compared to 18e- systems.

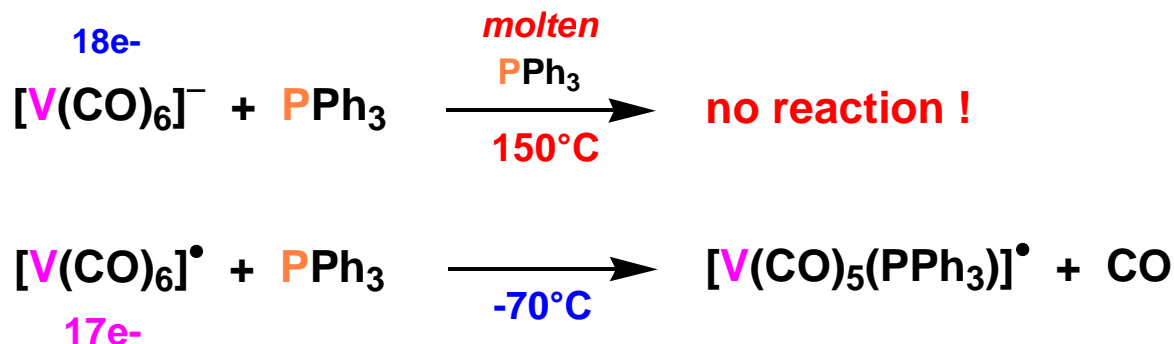

The mechanism for the 17e- $[\text{V}(\text{CO})_6]^\bullet$ radical is believed to be **associative** to give a 19e- complex. The 19e- configuration weakens and labilizes one of the V-CO bonds allowing a CO to dissociate, dropping the complex back to a 17e- configuration.

This is supported by the following experimental data:

$$\text{Rate} = k[\text{V}(\text{CO})_6]^\bullet [\text{PPh}_3] \quad (\text{second order})$$

$$\Delta S^\ddagger = -28 \text{ J/mol K} \quad (\text{negative entropy indicates ordered transition state})$$

This is a general observation for most odd electron complexes studied. The key is that the 19e- configuration is not as unstable as a 20e- electron count that places 2e- into a M-L antibonding orbital. In a 17e- complex, one electron is actually going into either a M-L bonding or non-bonding orbital, while the next electron goes into the M-L antibonding orbital. This makes the associative ligand addition considerably easier compared to an 18e- system.

Electron Transfer Catalysis (ETC)

One can “force” a stable, kinetically inert 18e⁻ complex into a considerably more reactive state by oxidizing it to a 17e⁻ configuration, thus opening up half a free orbital to which a ligand can bind initiating a ligand substitution reaction. The metal can then be reduced back to the 18e⁻ state.

Or one could reduce the metal to an unstable 19e⁻ state, which would labilize off the weakest coordinated ligand taking the metal complex down to a more reasonable 17e⁻ count. The metal center can then be oxidized back to a 16e⁻ state, giving an open orbital for a new ligand to coordinate to.

This is usually done electrochemically and since there is no net change in the number of electrons on the metal (oxidation is followed by reduction), it is considered a catalytic substitution reaction. An example is shown below.

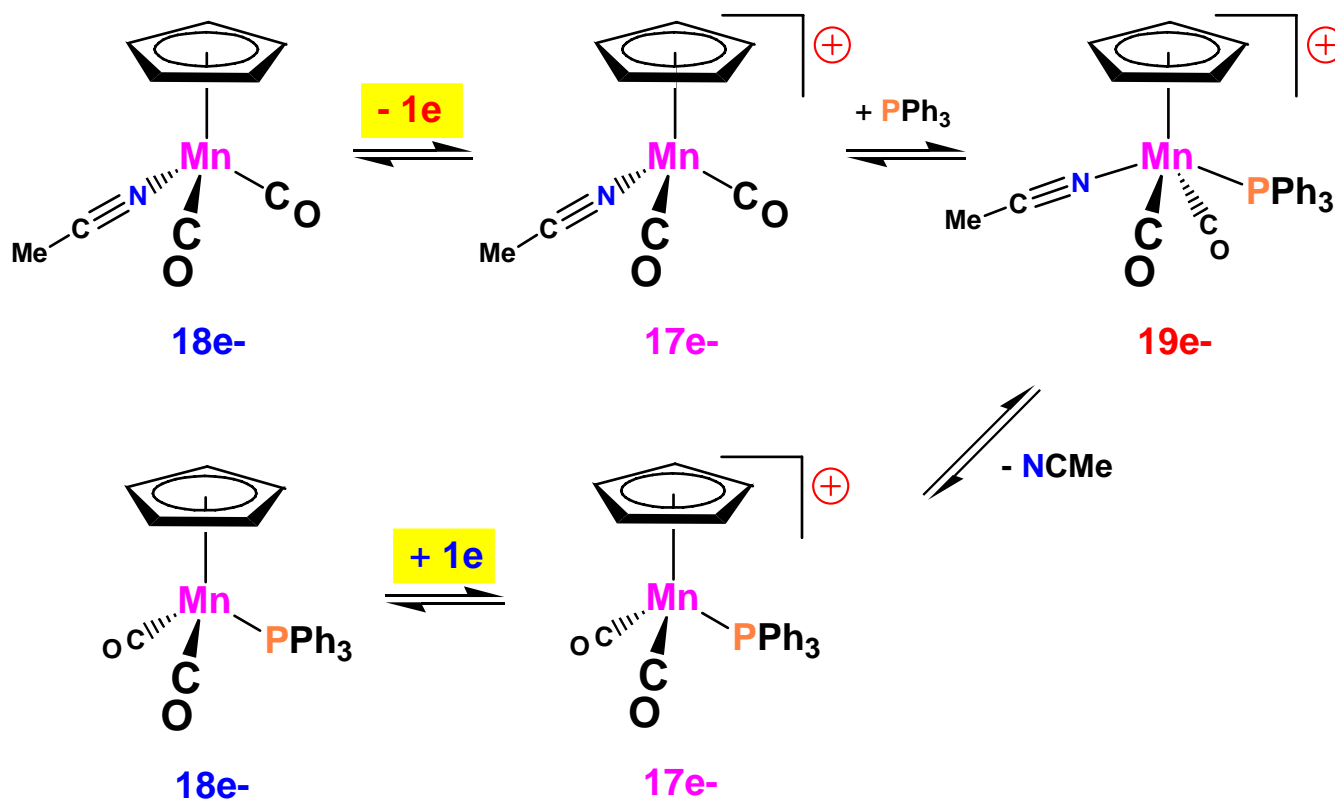

Problem: One could use electron transfer catalysis (ETC) to further activate the very inert *trans*-Cr(CO)₃(PMe₃)₃ complex that we discussed earlier for another CO substitution. To initiate the ETC you can either **oxidize** the complex to [Cr(CO)₃(PMe₃)₃]⁺ or **reduce** it to [Cr(CO)₃(PMe₃)₃]⁻. Only one of these would be likely to substitute off a CO ligand to replace it with a PMe₃ ligand. Which one would you use and why?

Oxidative Addition

An *oxidative addition* reaction is one in which (usually) a neutral ligand adds to a metal center and in doing so oxidizes the metal, typically by $2e^-$. The transferring of the two electrons from the metal to the incoming ligand breaks a bond in that ligand forming two new anionic ligands. At least one of these new anionic ligands ends up bonded to the metal center.

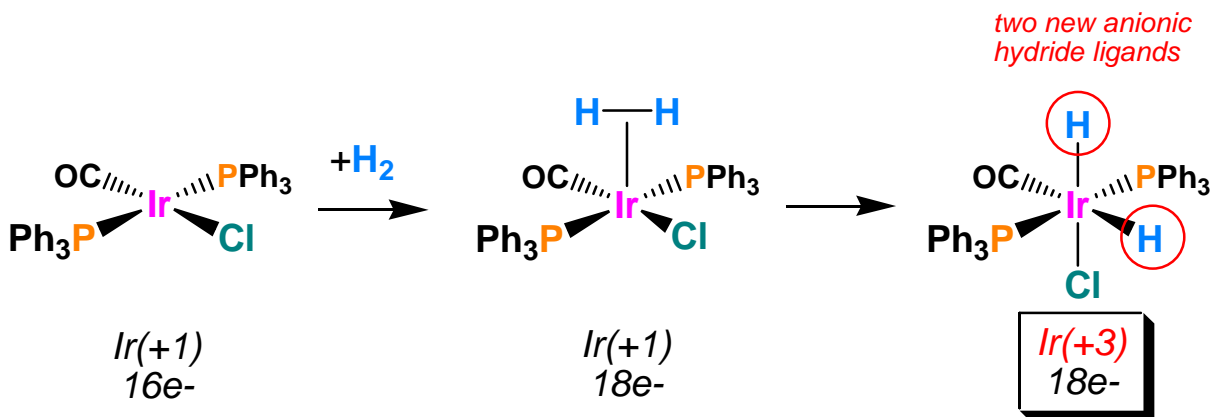

There are three main classes of molecules (substrates) that can perform oxidative additions to metal centers: **non-electrophillic**, **non-electrophillic “intact”**, and **electrophillic**.

Non-electrophillic: these molecules do NOT contain electronegative atoms and/or are not good oxidizing agents. Aside from H_2 , they are often considered to be “*non-reactive*” substrates. These molecules generally require the presence of an **empty orbital** on the metal center in order for them to pre-coordinate prior to being activated for the oxidative addition rxn.

**H_2 , C-H bonds, Si-H bonds, S-H bonds,
B-H bonds, N-H bonds, S-S bonds, C-C bonds, etc.**

H_2 is by far the most important for catalytic applications, followed by Si-H bonds, B-H, N-H, and S-H bonds. C-H bond activation and functionalization is very important, but still not practical.

Non-electrophillic “Intact”: these molecules may or may not contain electronegative atoms, but they do need to have a **double** or **triple bond** present. One needs a metal center with an **empty orbital** (16e- or lower count) in order to pre-coordinate the ligand before the oxidative addition occurs.

Unlike most of the other substrate molecules that break a single bond and form two separate **anionic** ligands upon the oxidative addition, these ligands have double or triple bonds and only **one** of the π -bonds is broken leaving the σ -bond intact. The ligand does pick up **two electrons** from the metal and becomes a **dianionic** ligand.

Typical “intact” ligands that can perform an oxidation addition without fragmenting apart are (O_2 can also act as an **electrophillic** substrate):

alkenes, alkynes, and O_2

One often needs to have electron withdrawing functional groups on the alkenes or alkynes in order to “*soup-up*” their electron-withdrawing ability in order to help promote the transfer of electrons from the metal to the ligand.

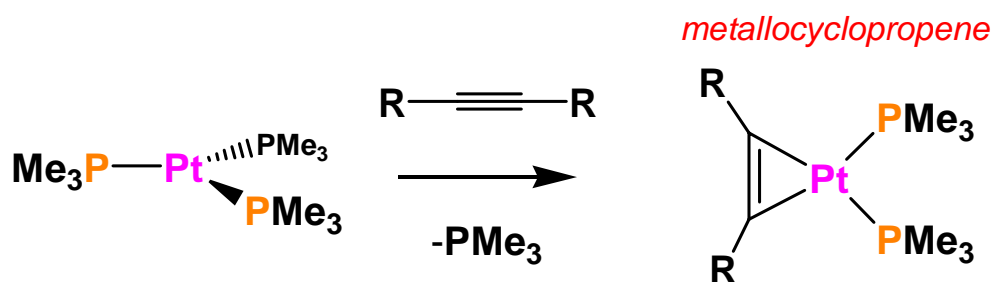

In this case we have oxidized the Pt center from Pt(0) d^{10} to Pt(+2) d^8 and generated a new **dianionic unsaturated alkenyl** ligand. Note that we have broken one of the alkyne π -bonds.

Electrophillic: these molecules do contain electronegative atoms and are good oxidizing agents. They are often considered to be “*reactive*” substrates. These molecules do NOT require the presence of an **empty orbital** (18e- is OK) on the metal center in order to perform the oxidative addition rxn.



The most common substrates used here are **R-X (alkyl halides)**, **Ar-X (aryl halides)**, and **H-X**. An example of the *oxidative addition* of CH₃Br to IrCl(CO)(PPh₃)₂ is shown below. Note that the starting metal complex in this case is 16e-:

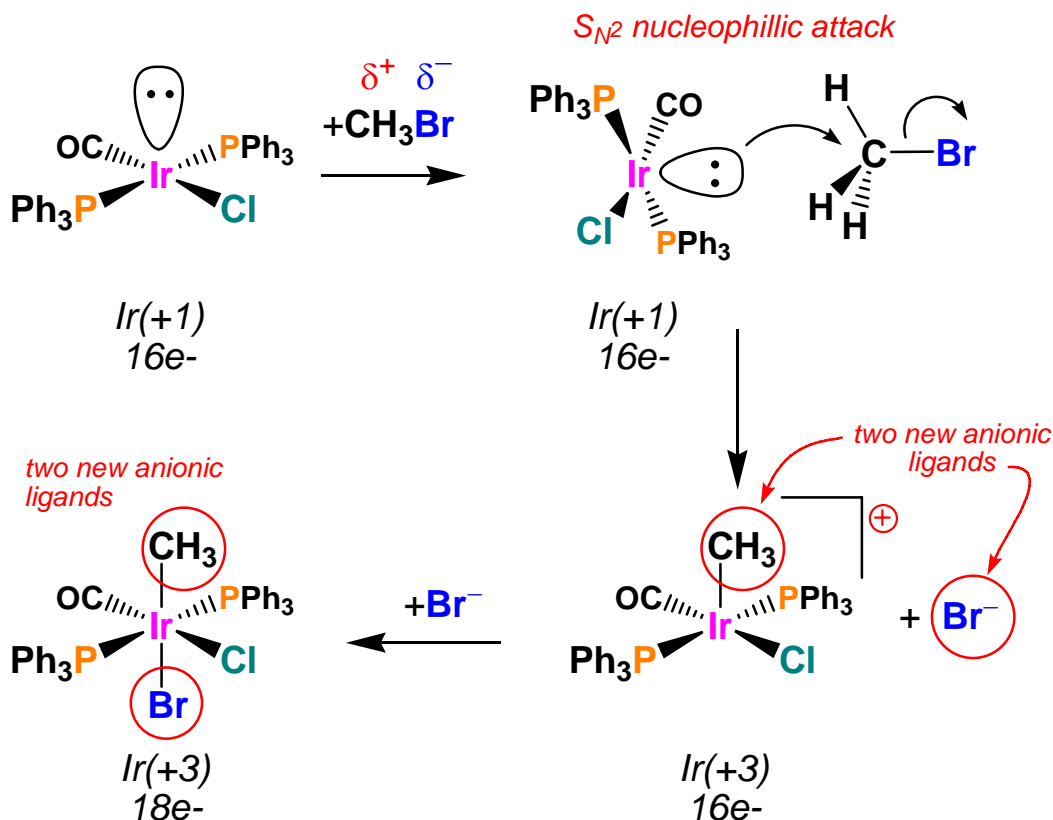

Note that the H₃C-Br bond is broken on the *oxidative addition* reaction generating two new **anionic** ligands: **CH₃⁻** and **Br⁻**. If the starting metal complex is **16e-** (as shown above) both ligands will usually end up coordinated to the metal to make an **18e-** complex.

In the case of a starting **18e⁻** complex (shown below) only **one** of the two anionic ligands (usually the strongest binding) generated from the oxidative addition will end up coordinated to the metal unless a separate substitution reaction occurs.

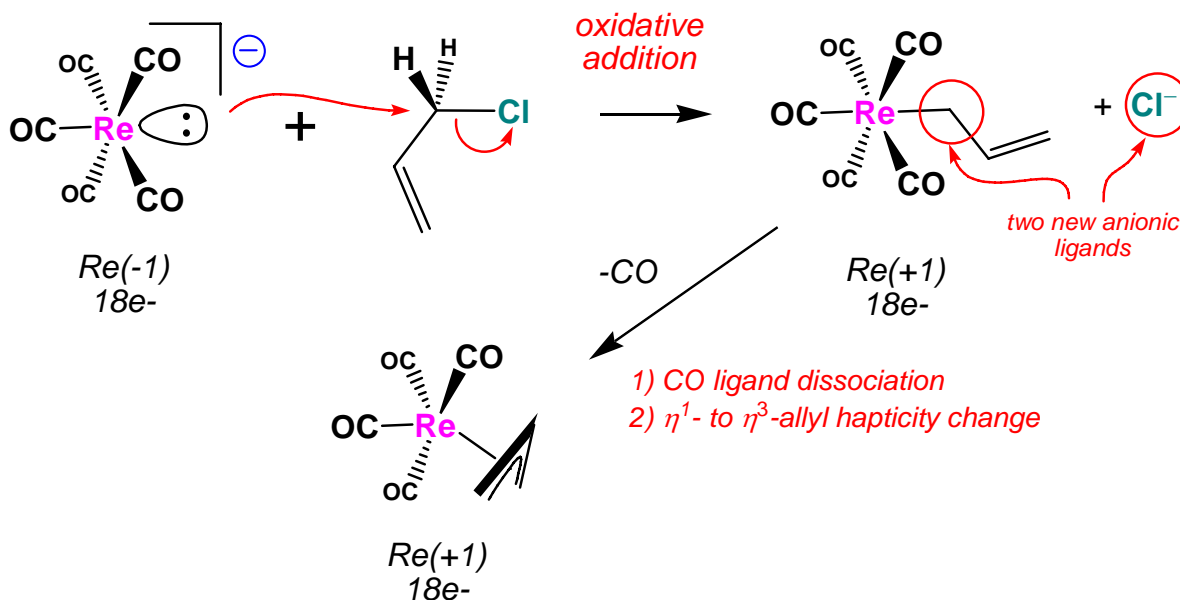

In this case the alkyl anion is the best donor ligand and easily “beats out” the more electronegative and poorly donating Cl⁻ anion. Note that the alkyl ligand (-CH₂CH=CH₂) initially coordinated to the Re after the oxidative addition is an **η¹-allyl** ligand and that it can convert to the generally more stable **η³-allyl** on CO ligand dissociation.

General Features of Oxidative Additions

Because oxidative addition involves oxidation (removal of electrons) of the metal center, the more **electron-rich** the metal is the easier the oxidative addition to the metal center will be. So in comparing two or more metal complexes to see which will be the most reactive towards a particular substrate for oxidative addition you would pick the metal center with the **strongest donor** ligands, fewest **π-acceptor** ligands, or most **negative** charge. Also remember that the non-electrophilic ligands (Class A) and “intact” ligands (Class C) usually require that there is an **empty orbital** (16e⁻ or lower) on the metal center in order to react.

Kinetic Data for Oxidative Addition Reactions of $\text{MX}(\text{CO})(\text{PR}_3)_2$

M	X	PR_3	Reactant	Rate Const ($\text{M}^{-1} \text{sec}^{-1}$)	ΔH^\ddagger (kcal/mol)	ΔS^\ddagger (J/mol K)
Ir	Cl	PPh_3	H_2	0.67	10.8	-23
	Br			10.5	12.0	-14
	I			> 100		
Ir	Cl	PPh_3	O_2	3.4×10^{-2}	13.1	-21
	Br			7.4×10^{-2}	11.8	-24
	I			30×10^{-2}	10.9	-24
Ir	Cl	PPh_3	CH_3I	3.5×10^{-3}	5.6	-51
	Br			1.6×10^{-3}	7.6	-46
	I			0.9×10^{-3}	8.8	-43
Ir	Cl	$\text{P}(\rho\text{-C}_6\text{H}_4\text{-OMe})_3$	CH_3I	3.5×10^{-2}	8.8	-35
		$\text{P}(\rho\text{-C}_6\text{H}_4\text{-Cl})_3$		3.7×10^{-5}	14.9	-28
Rh	Cl	PPh_3	CH_3I	12.7×10^{-4}	9.1	-44
		$\text{P}(\rho\text{-C}_6\text{H}_4\text{-OMe})_3$		51.5×10^{-4}	10.2	-43

Data adapted from "Principles and Applications of Organotransition Metal Chemistry", Coleman, Hegedus, Norton & Finke, University Press, 1987; refs: Chock & Halpern, *JACS*, 1966, 88, 3511; Ugo, Pasini, Fusi, Cenini, *JACS*, 1972, 94, 7364; Douek & Wilkenson, *J. Chem. Soc. (A)*, 1964, 2604. Rxns generally run in benzene at 25°C.

Notice the trends in the table above. The more electron-rich the metal center (better donating ligands) the faster the oxidative addition reactions. The one exception is the oxidative addition of CH_3I with the Ir-Cl, Br, I series of complexes. The slow down is caused by steric factors caused by the increase in size of the halide affecting the nucleophilic attack of the metal d_{z^2} orbital on the CH_3I to start the oxidative addition reaction.

The space-filling figures show two different views of the Ir-Cl (left) and Ir-I (right) complexes. The top view is looking down on the square plane with the halide oriented to the left. The bottom view is looking down the halide-Ir axis and illustrates how the larger size of the iodide causes more steric interactions with the phenyl rings on the PPh_3 restricting their rotation. The PPh_3 phenyl rings as shown in the top view partially block the axial coordination site. The larger size of the iodide causes pushes the phenyl rings more towards the metal causing more steric hindrance for incoming substrates.

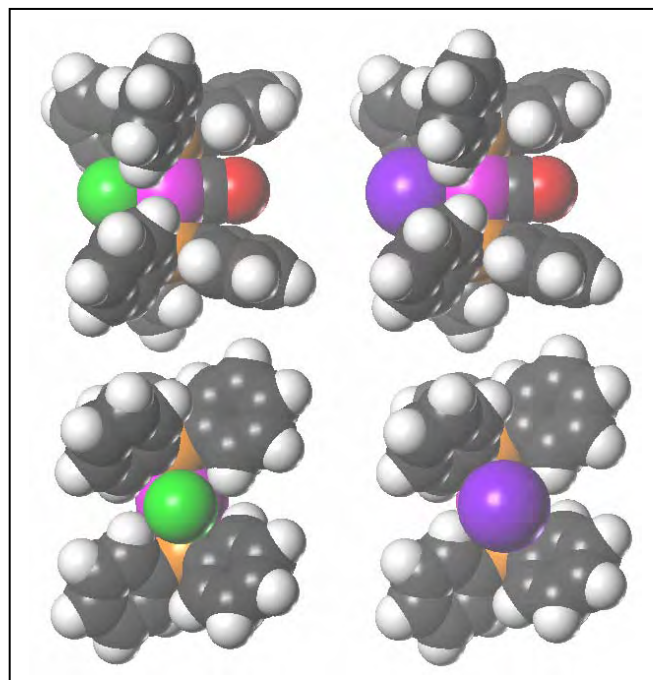

WARNING: d^0 metals can NOT do *oxidative additions*!! So always electron count the starting and final metal complexes to check out the overall electron-count, metal oxidation state and d -electron count!

Oxidative additions are easy to identify **IF YOU ELECTRON COUNT** the metal complexes. When an oxidative addition rxn occurs the metal will be oxidized, usually by $2e^-$. So, if you start with a metal in the 0 oxidation state (d^8), after the oxidative addition the metal will be in the +2 oxidation state (d^6). Once you get used to looking at organometallic rxns you will be able to identify common oxidative additions quite quickly. **H_2 , R-X, and H-SiR₃** are three of the most common substrates that perform *oxidative addition* reactions in catalytic cycles.

Problem: H_2 will do an *oxidative addition* most readily to which of the following complexes. Why?

a)

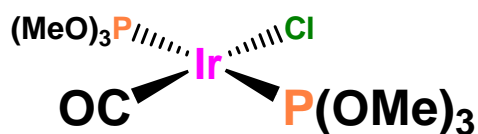

b)

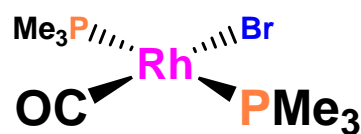

c)

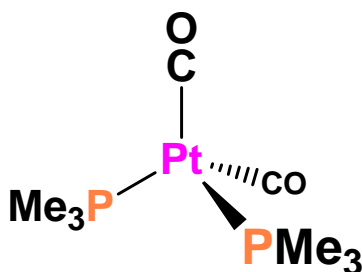

Problem: Cl_2 will do an **oxidative addition** most readily to which of the following complexes. Why?

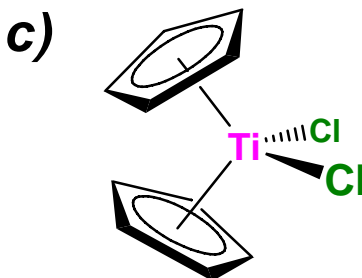
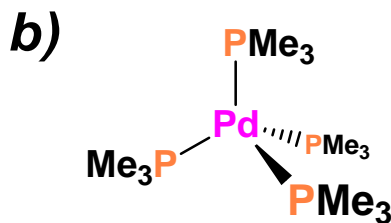
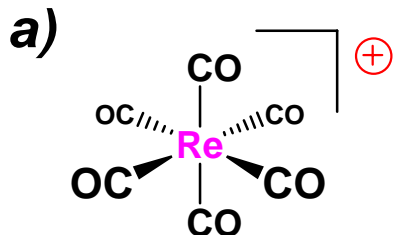

Problem: CH_3Br will do an **oxidative addition** most readily to which of the following complexes. Why?

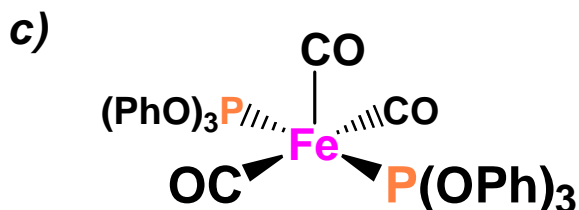
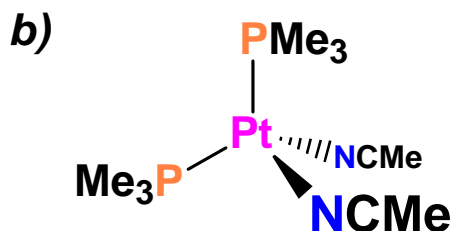
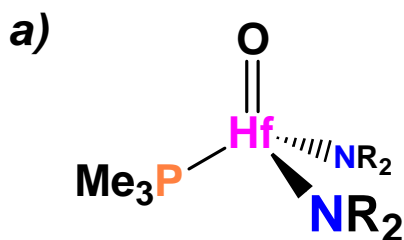

Oxidative Coupling

Consider the following reaction:

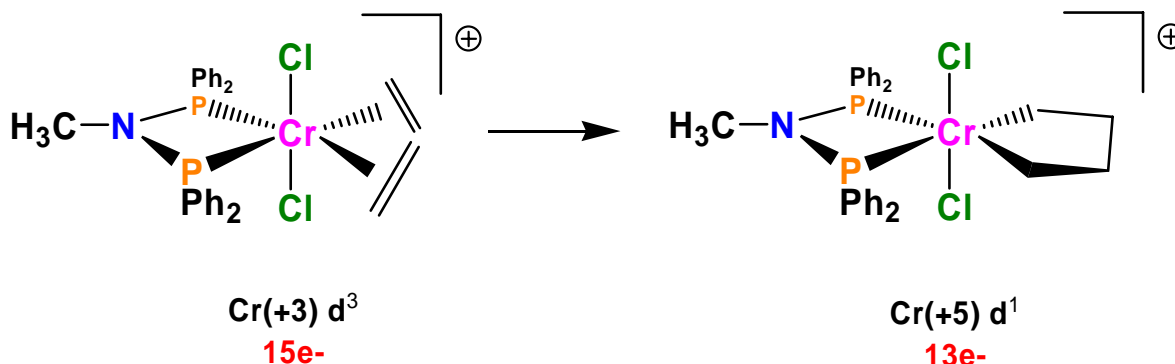

The Cr on the right now has two new anionic alkyl ligands forming a **metallocyclopentane** ring system. We have done an oxidative addition, but in forming a new bond between the two ethylene ligand (and losing the original double bonds) we have coupled the two ligands together.

While this is an **oxidative addition**, there is a special term for this type of reaction called **oxidative coupling**. The metal is being oxidized to create two new anionic ligands, but the original two neutral ligands also form a new bond between them, instead of fragmenting apart to make two new independent anionic ligands.

The driving force for this reaction is the formation of a new C-C σ -bond (stronger than a π -bond) and the creation of two new strongly donating anionic ligands that can better donate to the metal even though one has technically lowered the electron count.

Reductive Elimination

A *reductive elimination* reaction is the reverse of an *oxidative addition*. It is a reaction in which **two cisoidal anionic ligands** on a metal center couple together. Each anionic ligand pushes one electron back onto the metal center (in the case of a monometallic complex) to reduce it by $2e^-$. The coupled anionic ligands then usually fall off the metal center as a **neutral** molecule.

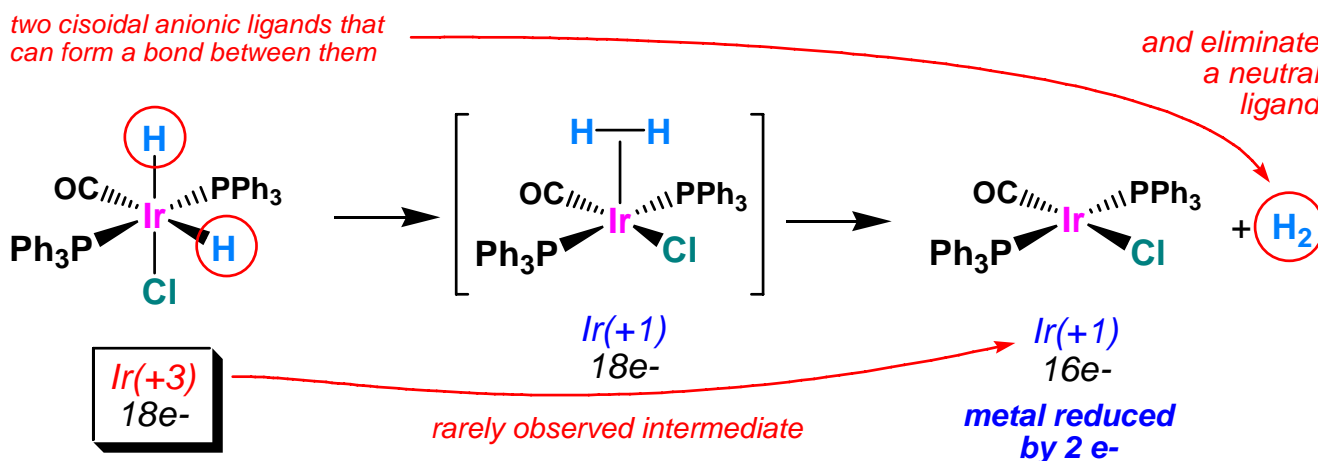

Since *electron-rich* metal complexes favor *oxidative addition*, the reverse is true for reductive elimination. Since *reductive elimination* involves pushing electrons back onto the metal center from two anionic ligands that are usually more electronegative than the metal center, it is best if the metal center is *electron deficient*. This can be accomplished by having electron-withdrawing ligands (e.g., CO), cationic charge(s), and/or coordinative unsaturation (sub- $18e^-$ counts).

While *reductive elimination* can occur from saturated $18e^-$ complexes (so long as the two ligands that you want to reductively eliminate are *cisoidal* to one another), it has been shown that reductive elimination can be promoted by a ligand dissociation generating an unsaturated and more electron-deficient metal center.

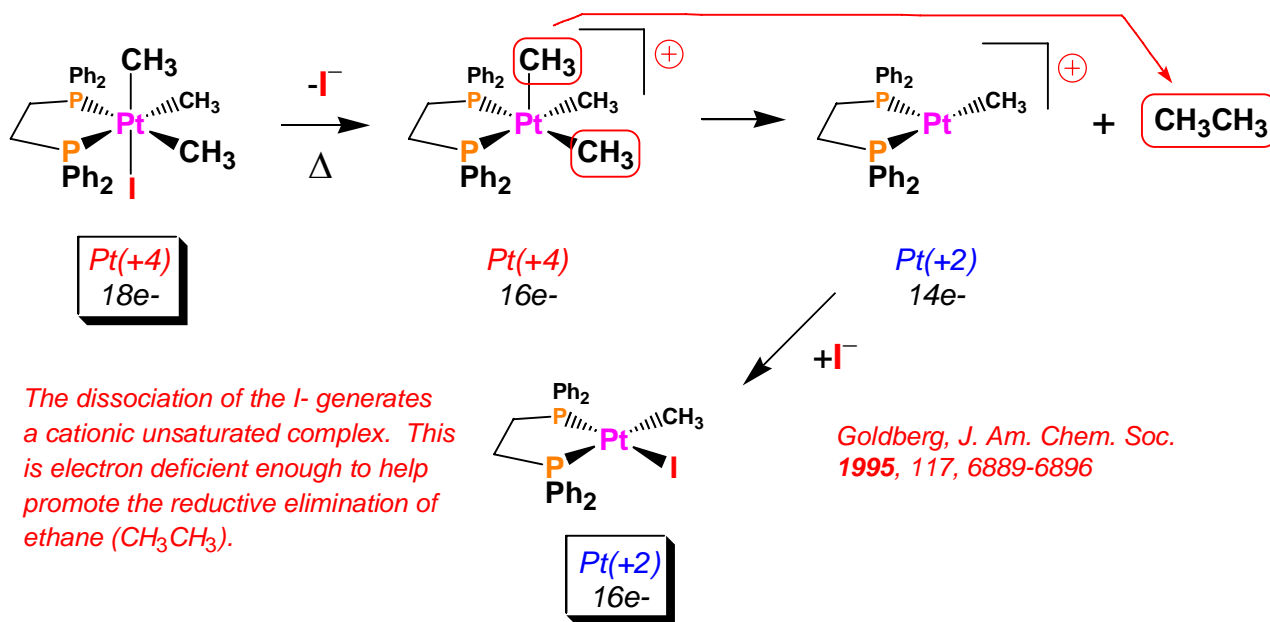

In studying the above system, it was also found that one could have **reductive elimination** of CH₃I from the starting 18e⁻ complex. This reaction, however, is very reversible due to the high reactivity of CH₃I for doing an **oxidative addition** back reaction with the electron-rich neutral Pt(+2) complex to make the Pt(+4) octahedral compound.

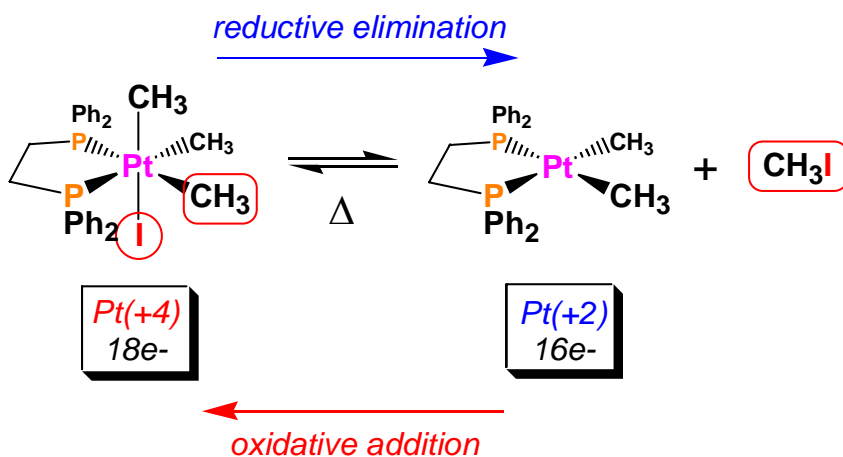

The reductive elimination of the CH₃I is kinetically favored. This is because the orbitals around the iodide anion are spherically symmetric and this makes it much easier to overlap with the alkyl group orbital to perform the reductive elimination. The sp³ directed orbitals on the two CH₃ groups are more difficult to overlap in order to get the reductive elimination to occur. But the reductive elimination of the CH₃CH₃ is thermodynamically considerably more favorable and the back oxidative addition much more difficult.

Problem: Which of the following compounds will be most likely to do a reductive elimination of ethane ($\text{CH}_3\text{-CH}_3$)? Why?

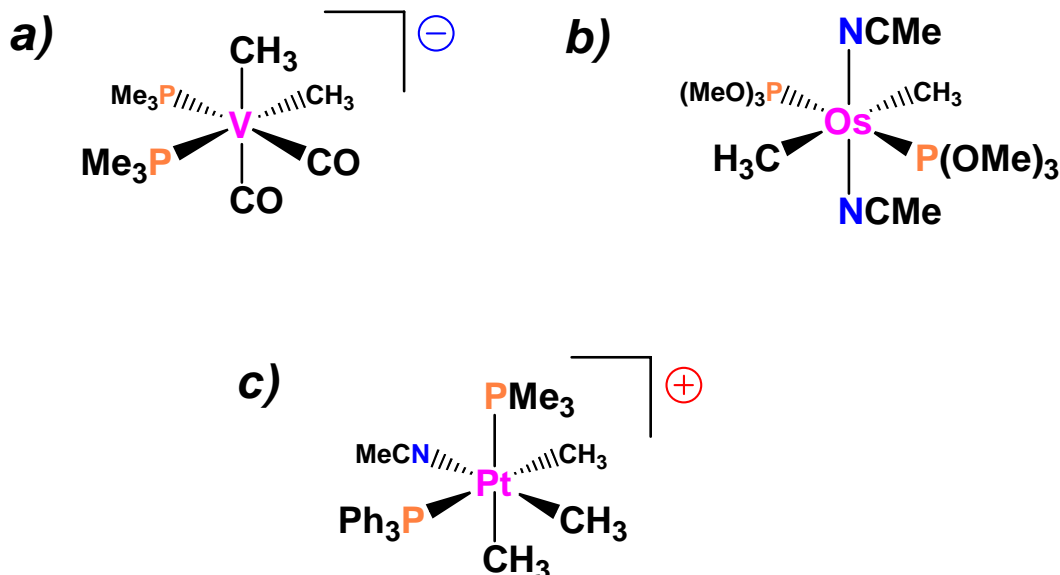

Problem: Which of the following mechanisms makes the most sense for the indicated reductive elimination (direct route or dissociative route via a cationic intermediate)? Why?

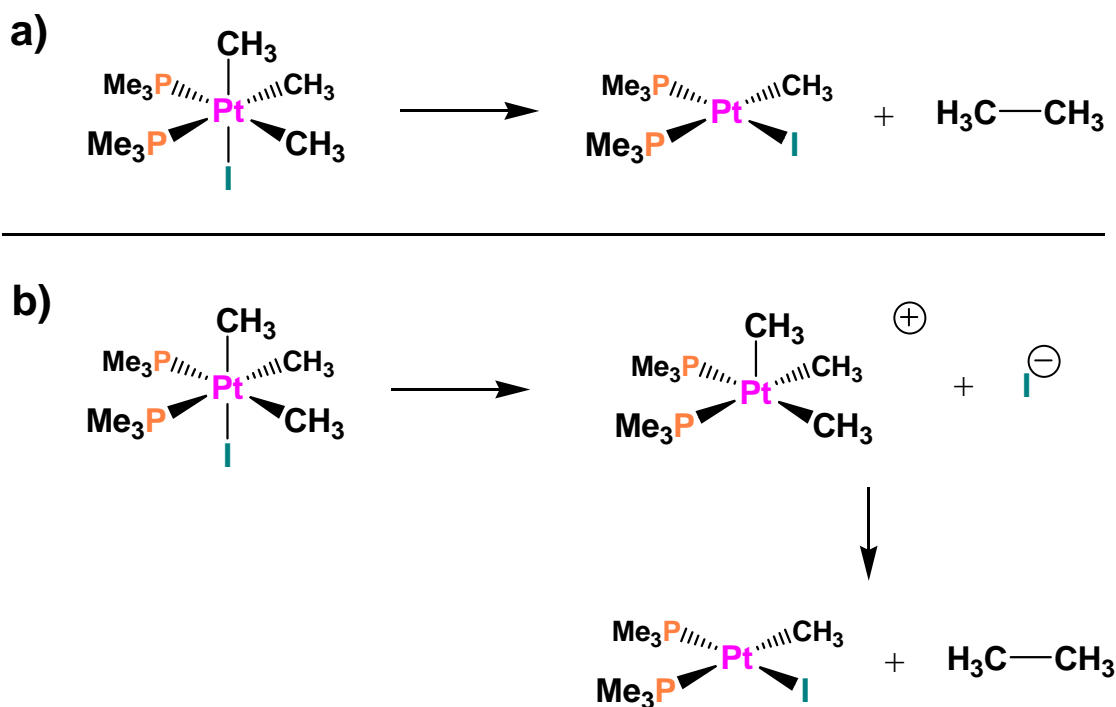

Binuclear Systems

Complexes with two (or more) adjacent metal atoms can also participate in **oxidative addition** and **reductive elimination** reactions. This often involves both metal centers. If so, then each metal changes its oxidation state by only ± 1 , instead of ± 2 as occurs with single metal centers.

This also often involves the making or breaking of a M-M bond, depending on what is present in the starting complex.

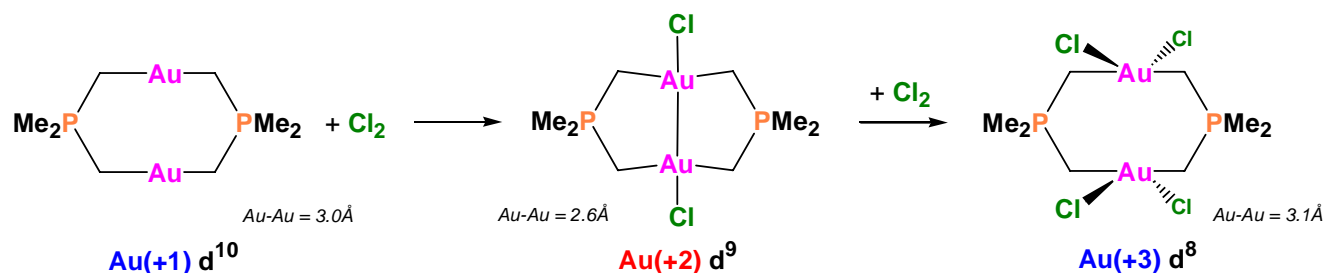

Below is a somewhat usual case of a C-C bond oxidative addition to a dimetal unit. The reverse reaction could also be considered a **reductive coupling** instead of a **reductive elimination** since the ligand stays coordinated to the metal center:

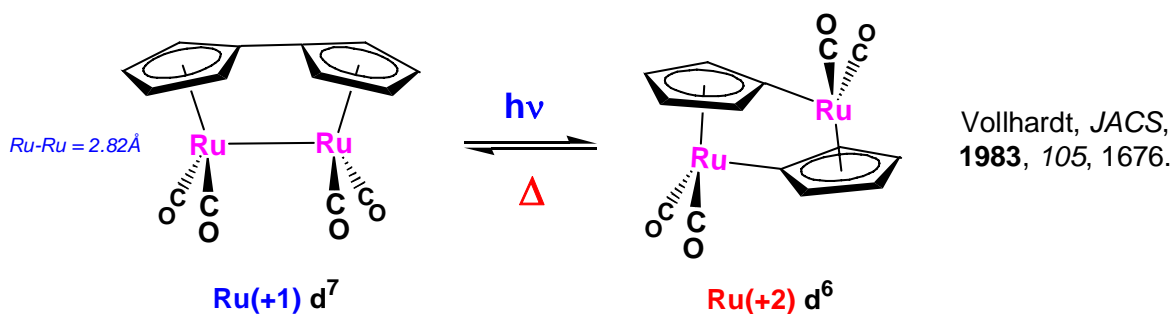

The next two examples involve **reductive eliminations** across a bimetallic unit:

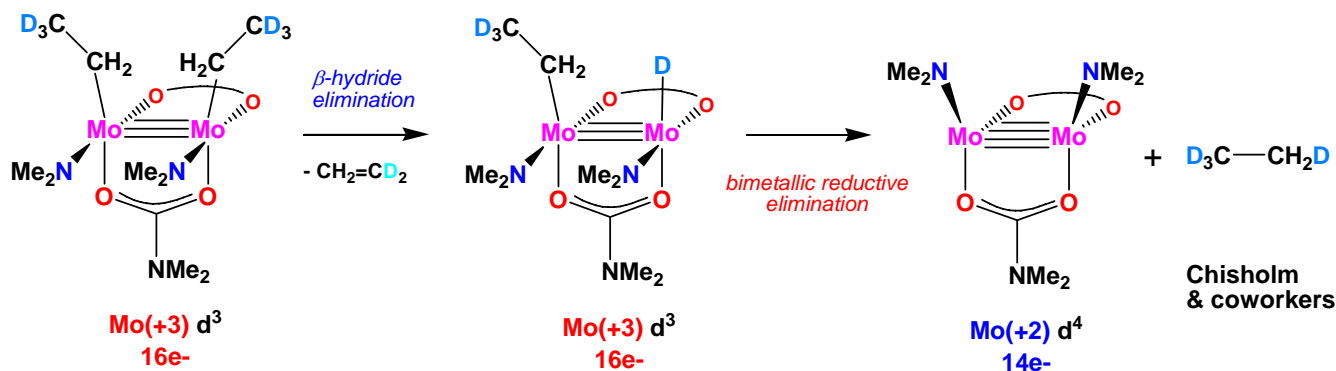

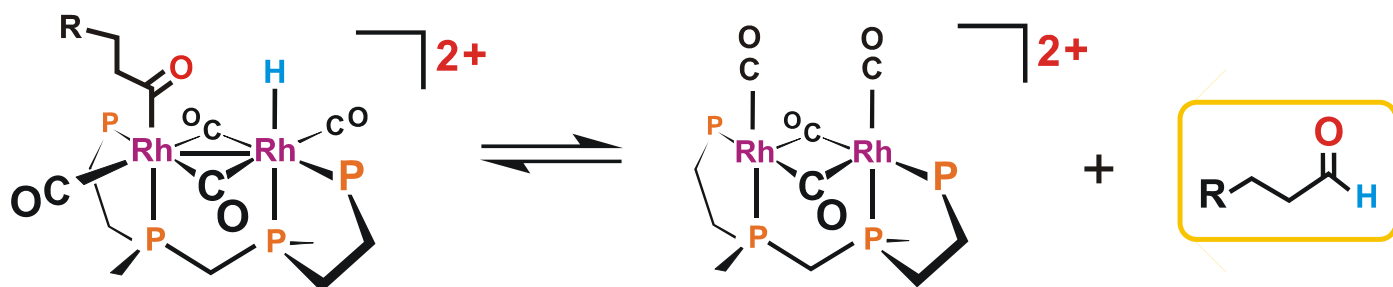

In general bimetallic reductive eliminations occur across two metals when there is a M-M bond and when one can have good overlap of the two groups orbitals. Notably, there are very few if any examples of two alkyl groups performing a bimetallic reductive elimination.

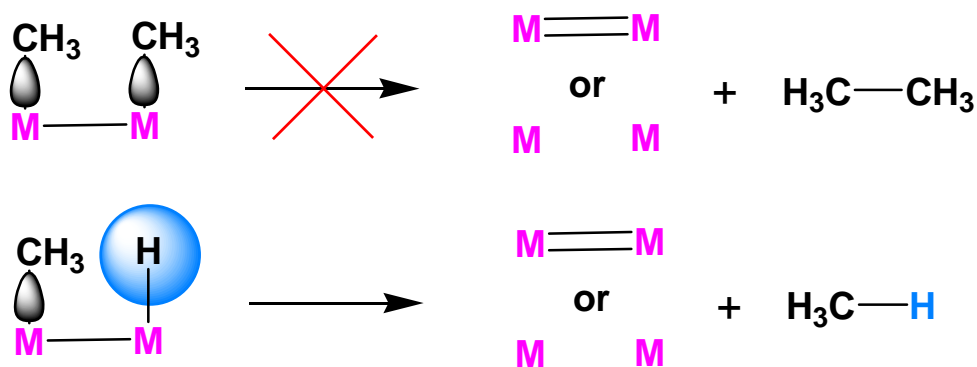

This is due to the very poor overlap of the directed sp^3 hybrid orbitals on the alkyls used to bond to the metal centers. Alkyl and hydride eliminations have been observed, no doubt due to the spherically symmetric orbital on the hydride that can overlap with the carbon sp^3 hybrid orbital promoting the reductive elimination. The reductive elimination of two hydrides is well known and quite common.

Problem: Which of the two bimetallic complexes shown below will be most likely to do a reductive elimination of H_2 ? Why?

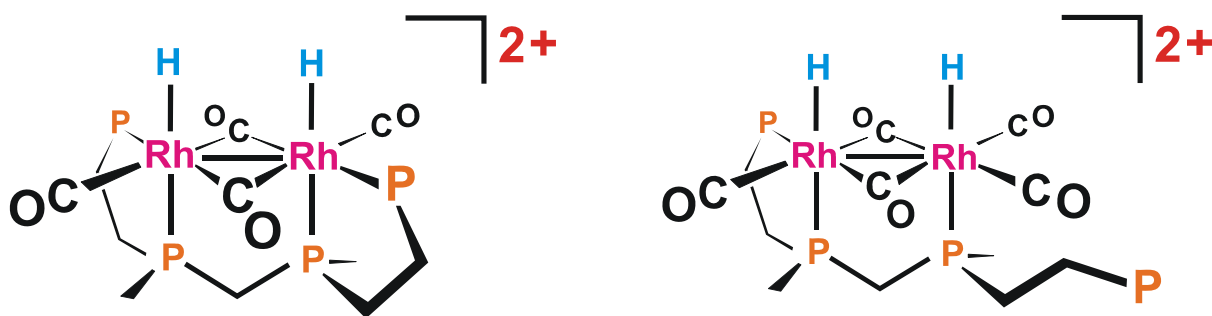

Migratory Insertion

A *migratory insertion* reaction is when a **cisoidal anionic and neutral** ligand on a metal complex couple together to generate a new coordinated **anionic** ligand. This new anionic ligand is composed of the original neutral and anionic ligands now bonded to one another.

General Features:

- 1) No change in formal oxidation state (exception: alkylidenes)
- 2) The two groups that react must be **cisoidal** to one another
- 3) A vacant coordination site is generated by the migratory insertion. Therefore, a vacant site is required for the back elimination reaction (e.g., β -hydride elimination). A trapping ligand is often needed to coordinate to the empty site formed from a migratory insertion in order to stop the back elimination reaction.
- 4) Migratory insertions are usually favored on more electron-deficient metal centers.

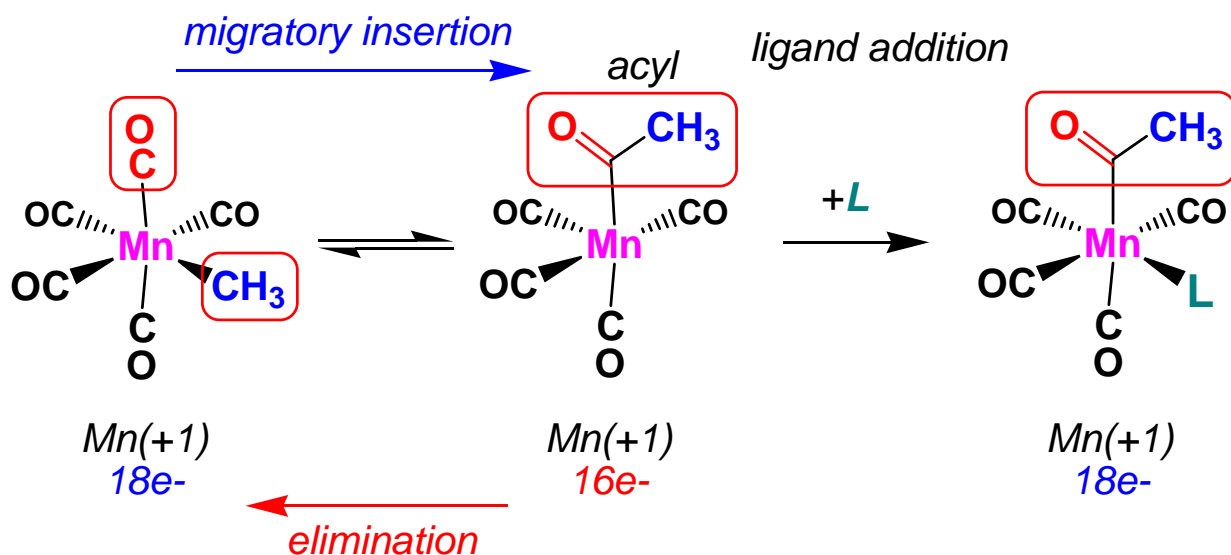

The following are common **anionic** and **neutral** ligands that can do *migratory insertion* reactions with one another:

Anionic: H^- , R^- (alkyl), Ar^- (aryl), $acyl^-$, O^{2-} (oxo)

Neutral: CO , alkenes, alkynes, carbenes

CO and alkyl migratory insertions (as shown above) are extremely important and are often generically referred to as **carbonylation** reactions. Hydride and CO migratory insertions to produce formyl groups are not common due to the thermodynamic instability of the formyl-metal interaction.

Some Electronic effects

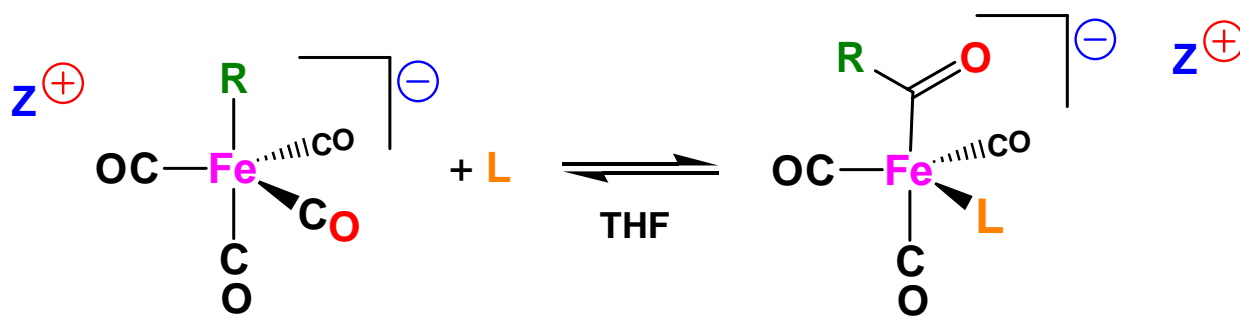

best Lewis acid - can coordinate to electron-rich CO ligands and drain off some e- density



strongest coordinating ligand - best trapping ligand



most electron-rich alkyl group makes the best nucleophile for migrating to the electron-deficient CO



Note that the acyl ligand formed is not as good a donor compared to the starting alkyl. But the metal has gained (replaced) an electron withdrawing CO ligand with a better donating phosphine. Thus, the overall reaction with a trapping ligand is usually towards the migratory insertion.

The reason that more electron-deficient metals favor CO-alkyl migratory insertions is that makes the carbon atom of the CO more electrophilic and susceptible to nucleophilic attack from the more electron-rich alkyl group.

Migration vs. Insertion

There are two different “directions” that a migratory insertion can occur. A migration is when the anionic ligand moves and performs a nucleophilic-like intramolecular attack on the electrophilic neutral ligand. An insertion is when the neutral ligand moves and “inserts” into the bond between the metal and anionic ligand. Both of these pathways are illustrated below:

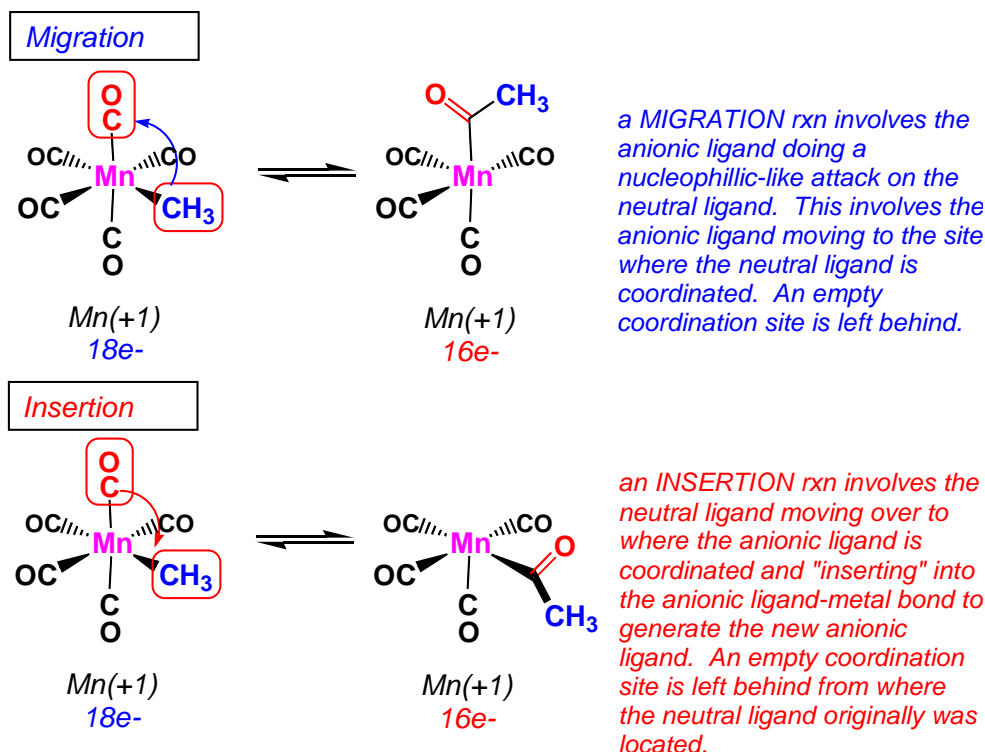

While most systems studied have been shown to do migrations, both are possible. The following example shows a system where both are very similar in energy and the solvent used favors one or the other.

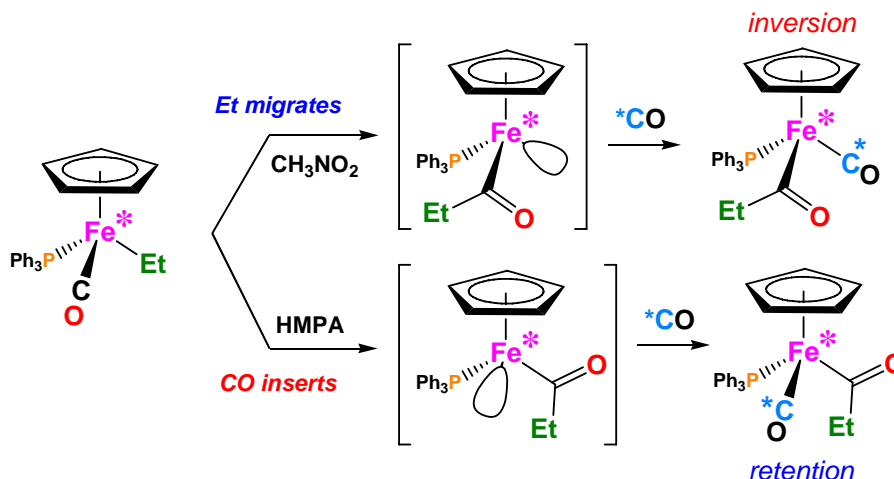

We generally do NOT worry about the exact pathway, that is why we use the redundant term “*migratory insertion*” to indicate that either directional pathway is fine and we don’t know (or care) exactly how the reaction is proceeding. Many organometallic chemists short-cut this and just say *insertion* reaction. They do not usually mean that they know what the mechanism is.

Alkene Migratory Insertions

Alkene and hydride/alkyl migratory insertions are also extremely important and an example is shown below:

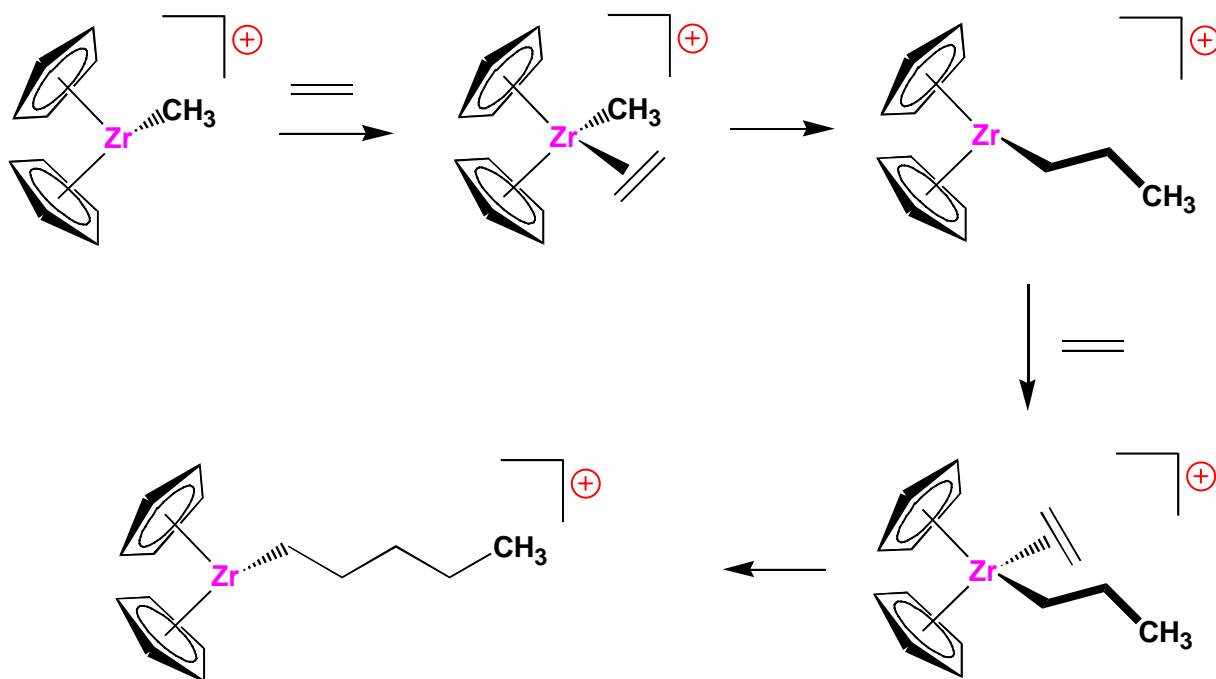

This is the basis for almost all transition metal-based **polymerization** catalysts. A polymerization rxn is just many, many **migratory insertions** of an alkene and alkyl (the growing polymer chain) interspaced with alkene ligand addition reactions.

An alkene and a hydride usually react via a **migration** of the hydride to the coordinated alkene ligand:

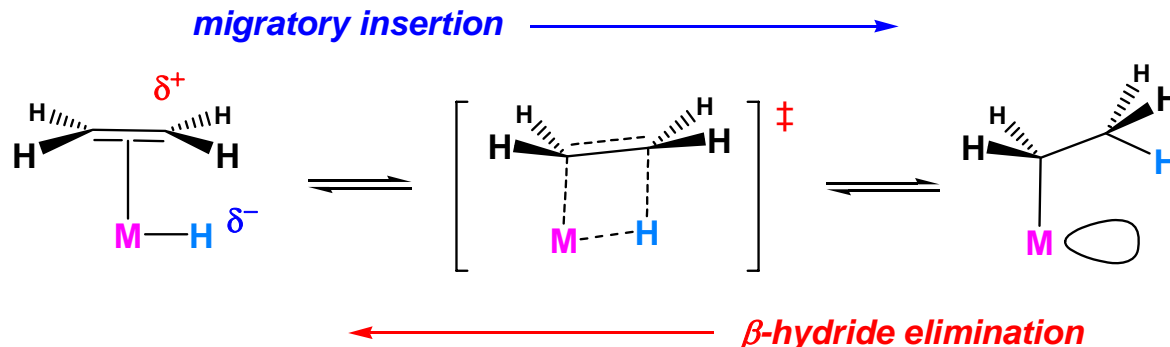

The backwards reaction, of course, is a **β -hydride elimination** and is usually quite favorable if there is an empty orbital cis to the alkyl ligand. Thus, the general importance of having a trapping ligand to coordinate to the empty orbital generated from the migratory insertion.

Bercaw and coworkers demonstrated via spin saturation NMR techniques that the Nb-H-alkene complex shown below was constantly performing a migratory insertion, but that the final product was only observed when a trapping ligand was added to the reaction mixture.

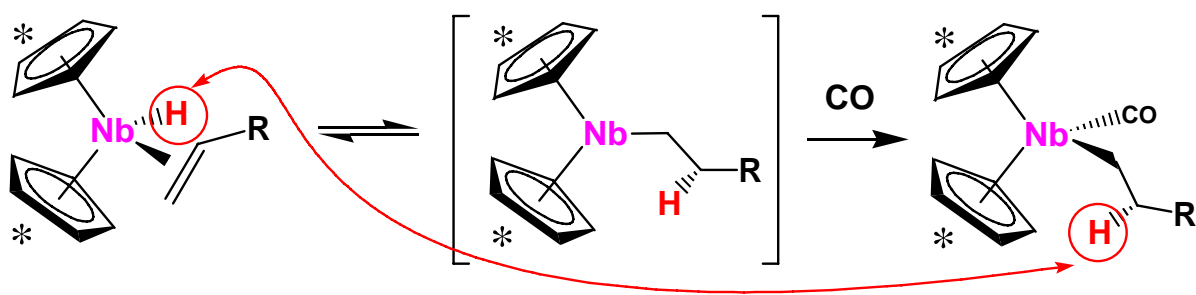

NMR irradiation of the Nb-hydride resonance affects the NMR resonance for the alkyl hydride, demonstrating that they are connected by the migratory insertion mechanism

Problem: Why don't either of the complexes shown below do alkene-hydride migratory insertions at room temperature?

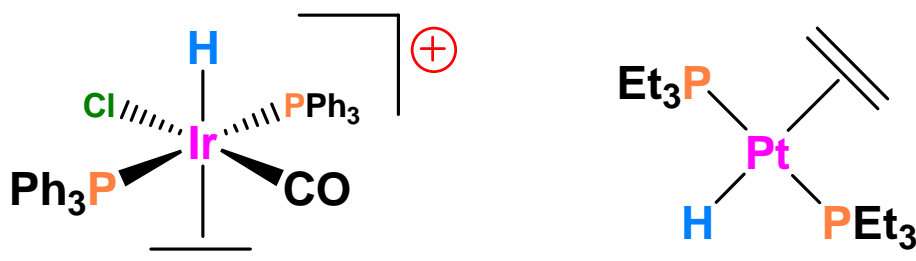

Problem: Sketch out and label the two mechanistic steps (in the correct order) that are occurring for the following reaction.

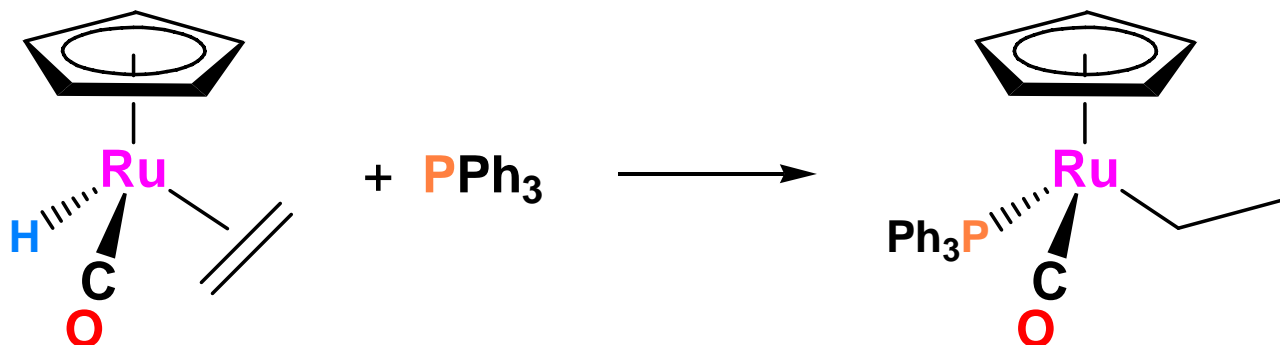

Alkynes can also do migratory insertions to produce vinyl groups as shown below:

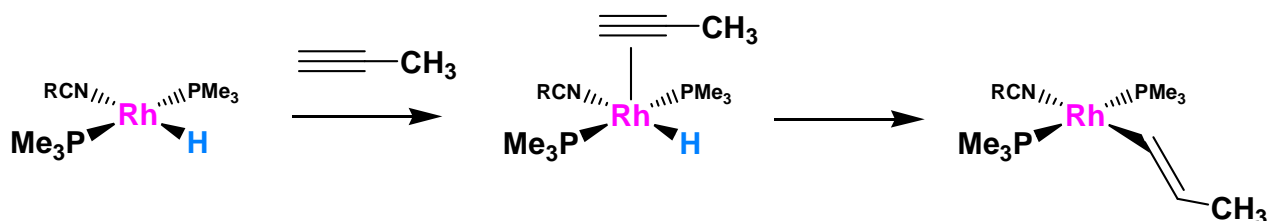

An intramolecular alkyne migratory insertion to make a lactone ring system:

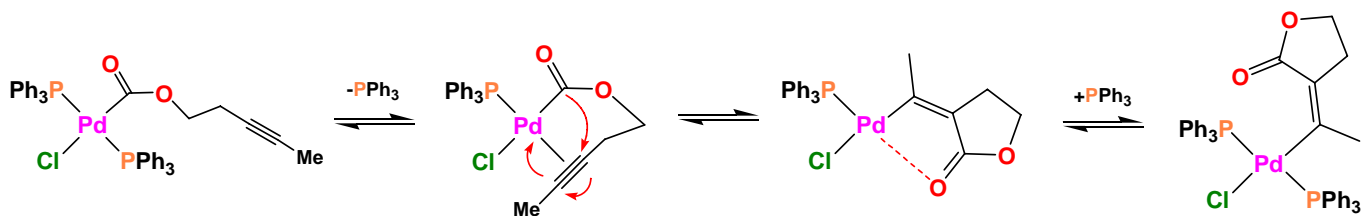

Agostic C-H to Metal Interactions – “Frozen Migratory Insertion”

On occasion one can find an alkene-hydride migratory insertion that doesn't go all the way:

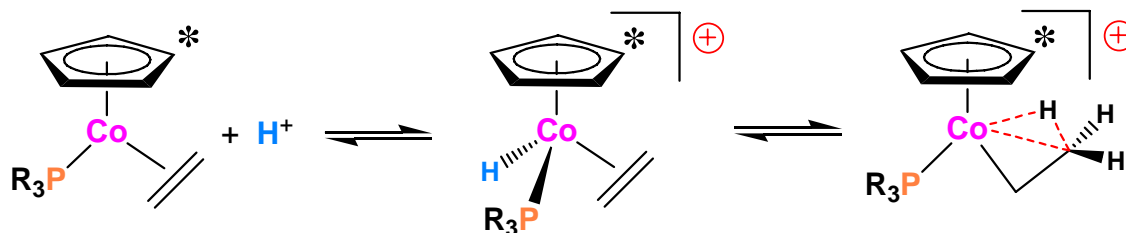

*One of the C-H bonds of the methyl group is within bonding distance to the Co center. This is called an **Agostic** C-H bond interaction.*

Normally this is a transition state structure for a **hydride-alkene migratory insertion** or a **β -hydride elimination**. In some cases, however, it can be observed as a ground-state stable structure.

Because the C-H bond is sharing some of its σ -bond electron density with the metal, the C-H bond is *weakened*. This produces some relatively clear-cut spectroscopic characteristics:

- 1) $\nu_{\text{C-H}}$ infrared stretching frequency is lowered to the mid-2500 cm^{-1} region from a normal value of 2900-3000 cm^{-1}
- 2) the $J_{\text{C-H}}$ coupling constant in the ^{13}C NMR is lowered to around 70-90 Hz from a normal value of 150 Hz.
- 3) the ^1H chemical shift of the agostic proton is in the -10 to -15 ppm region, much like a metal-hydride resonance.

Also note that since the agostic C-H bond is in between a migratory insertion and a β -hydride elimination, small changes in steric or electronic factors on the metal can push it one way or the other. Also since the agostic C-H bond to metal interaction is usually fairly weak, the addition of a better ligand can displace usually in the direction of the M-alkyl complex.

Carbene Migratory Insertions

Carbene (or alkylidene) ligands can also do migratory insertions with adjacent anionic ligands:



Note that we have somewhat of an electron-counting problem here. Normally a migratory insertion refers to a **neutral ligand** reacting with an **anionic ligand** to produce a **new anionic ligand**. But if we electron-count the carbene as a **dianionic** ligand, we are reacting a monoanionic ligand (**X**) with a dianionic ligand (carbene) to make a new monoanionic ligand. This changes the oxidation state of the metal center and is now formally what we would call a **reductive coupling reaction** (since the metal is being reduced and we are coupling together two ligands).

What most people do is to consider the carbene (or alkylidene) as being a **neutral ligand**. That resolves the electron-counting “problem.”

Note also that in the case of **X = H⁻**, the reverse reaction is called an **α-hydride abstraction or elimination**.

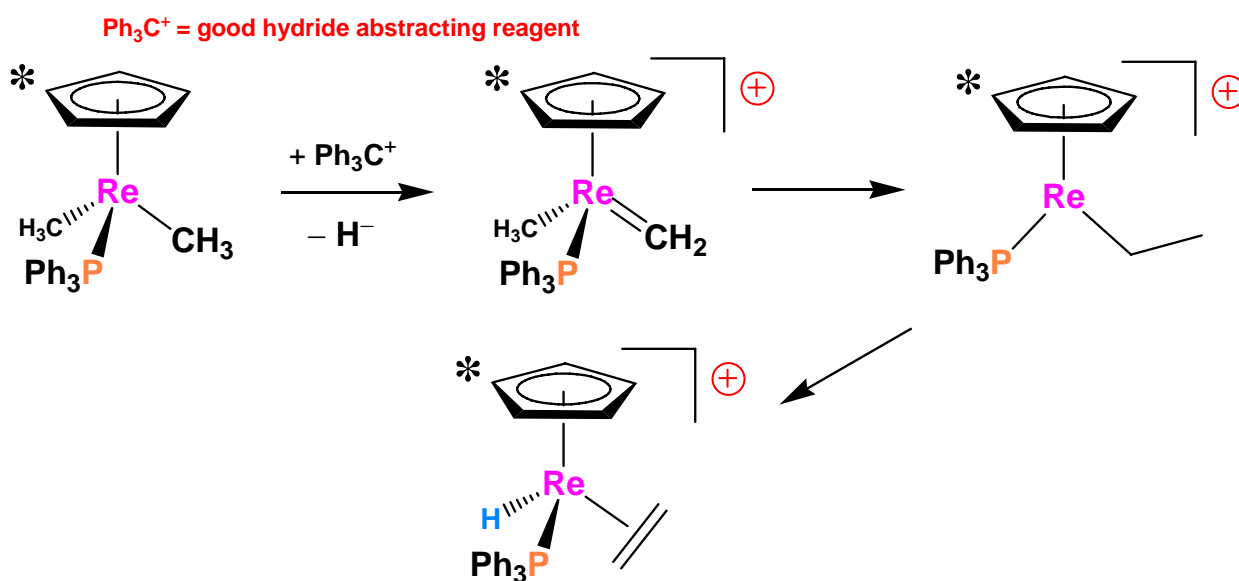

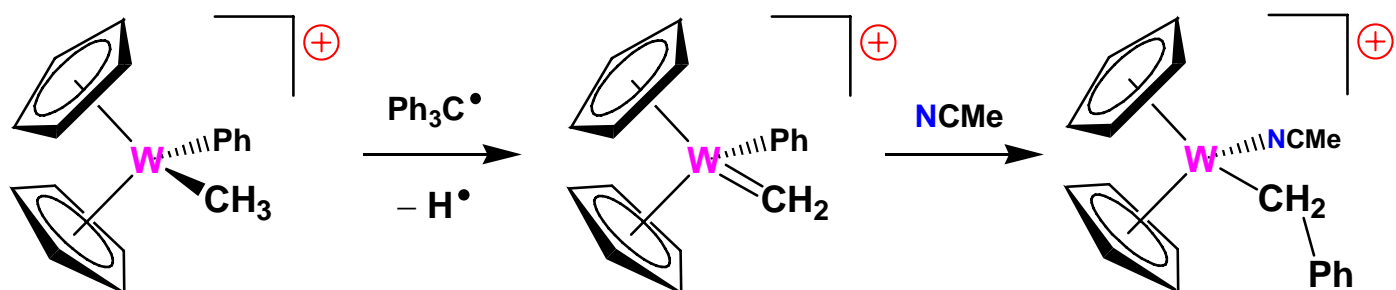

Note that these are reactive “carbenes” and not heteroatom stabilized. They are also probably more Schrock-like, but somewhat electrophillic (note the presence of positive charge on both examples). Fischer carbenes with heteroatoms would probably not be reactive enough for these types of migratory insertion reactions.

Eliminations

Elimination reactions are just the reverse of migratory insertion reactions. The various common elimination reactions are as follows:

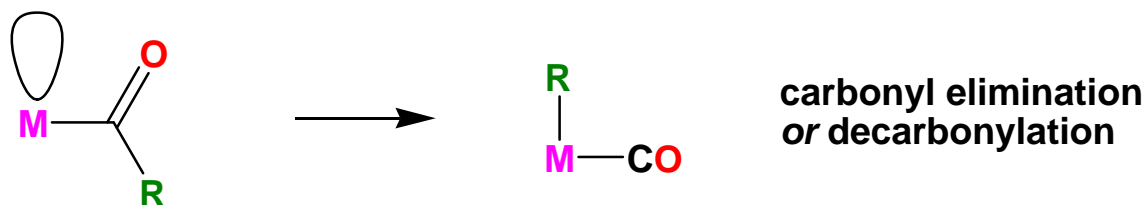
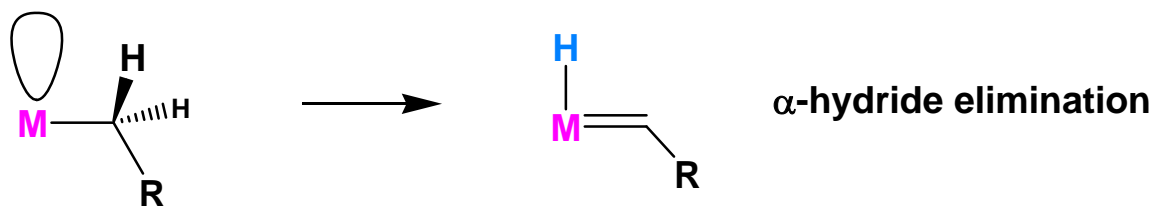
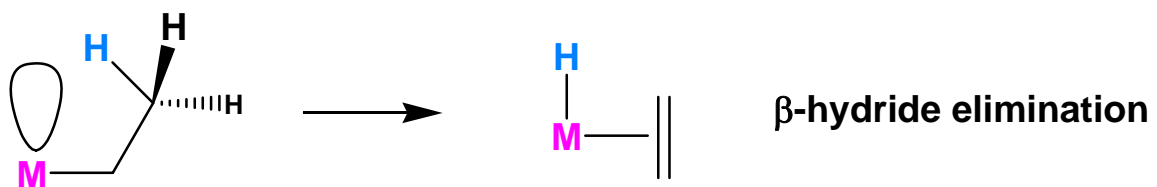

The key points to remember are:

- 1) No change in formal oxidation state (exception: alkylidenes)
- 2) You must have an empty orbital that is **cisoidal** to the group that you are doing an elimination reaction on. Alternatively, a cisoidal labile ligand that can easily dissociate to open up an empty orbital.

One of the hardest elimination reactions is the breaking of a C-C bond. For example the following **migratory insertion** is quite common and plays a critical role in polymerization catalysis:

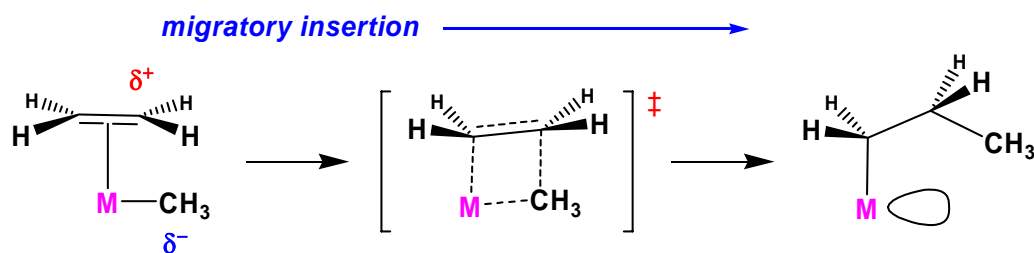

But the reverse **methyl elimination** rxn is very difficult:

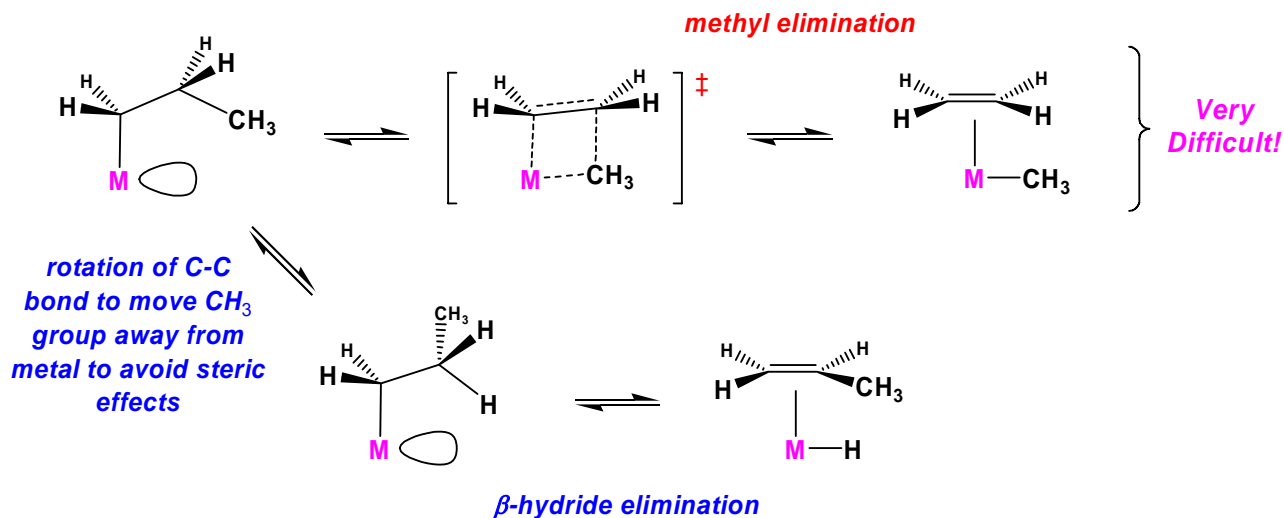

One reason for this is that the C-C σ -bond is surrounded by more reactive C-H bonds that short-circuit the attack on the C-C bond and can instead give a β -hydride elimination. The directed nature of the sp^3 hybridized C-C σ -bond also makes overlap with the empty metal orbital quite difficult.

One unusual example of what is believed to be a methyl elimination reaction is involved in the following transformation (Bergman, *JACS*, 2002, 124, 4192-4193):

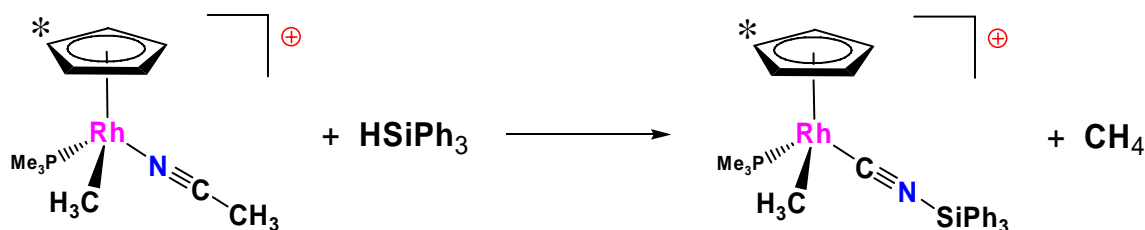

The proposed mechanism for this reaction is shown below:

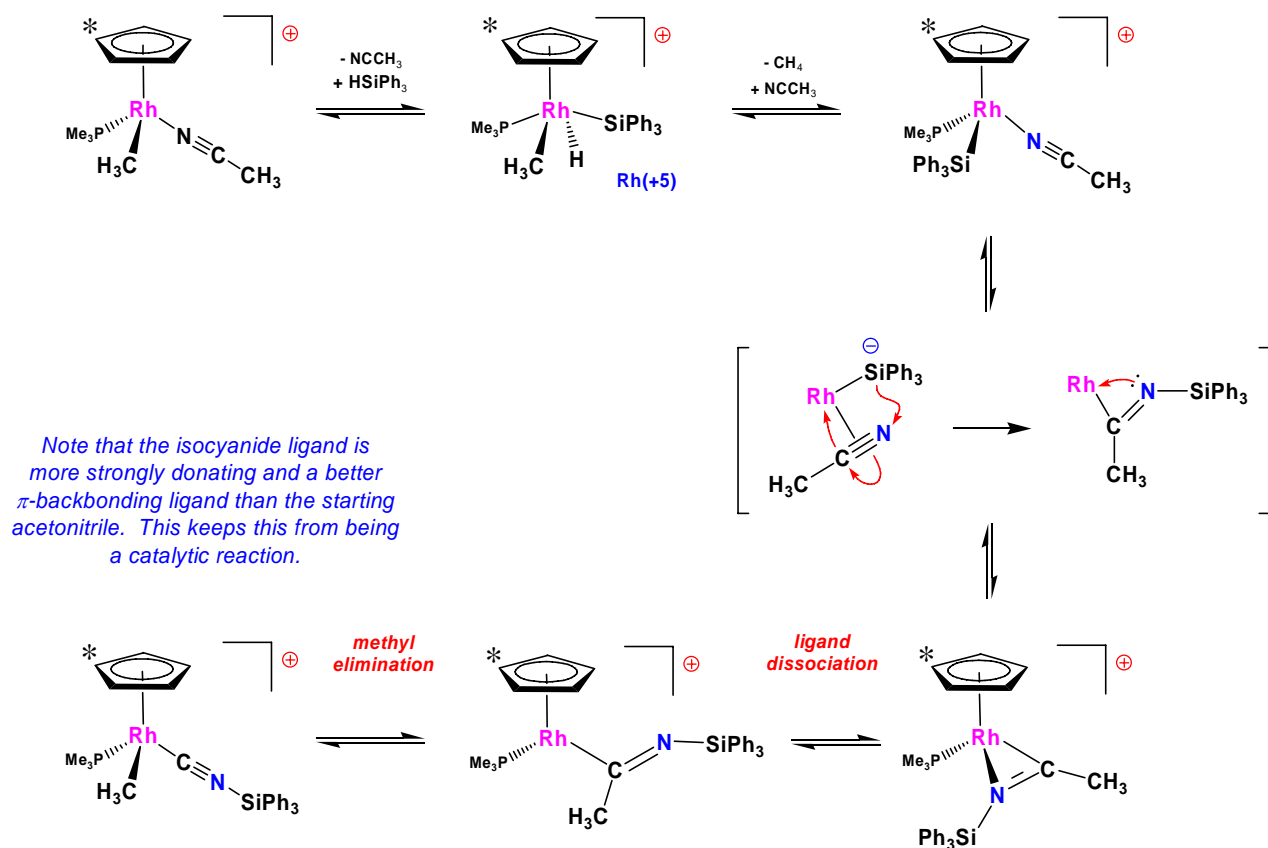

One reason that the methyl elimination reaction occurs here is that the β -hydride elimination reaction generates a high energy ketene-imine:

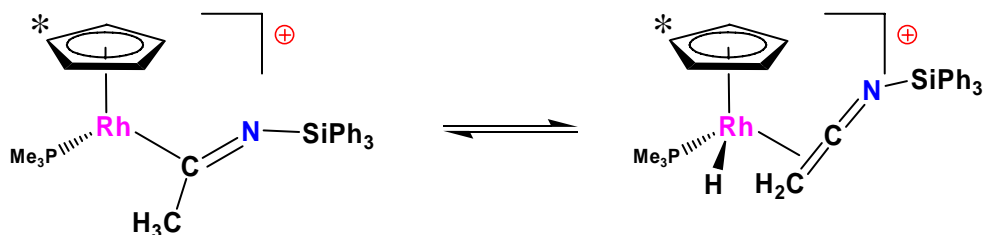

Problem: Identify each step in the following mechanism. Some steps may have several things occurring.

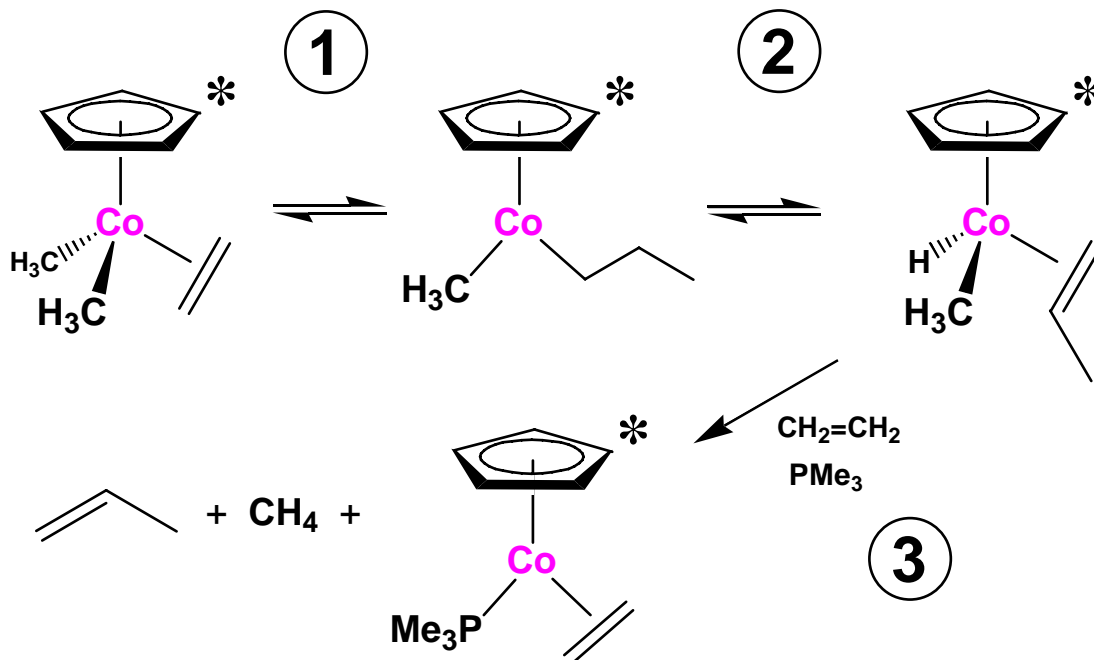

Problem: Sketch out a detailed mechanism and label each step for the following overall reaction.

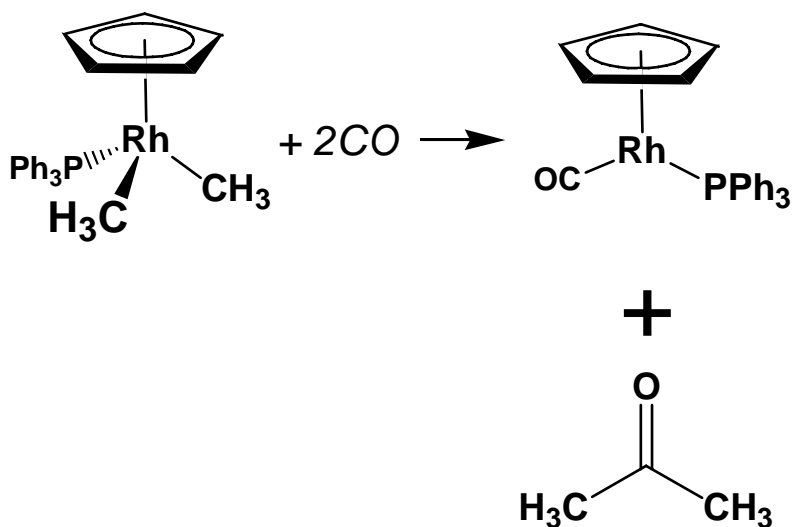

Summary of Industrial Catalytic Processes

Process	Typical Catalysts
Petroleum Refining	
Cracking	Pt/Re on alumina, Zeolites
Reforming	Pt/Re/Ge/Sn on alumina (dehydrogenation)
Hydrocracking	alumina, zeolites, Pt
Alkylation	H ₂ SO ₄ , HF
Hydrodesulfurization	(Mo-Co) oxides, (Mo-Ni) oxides
Hydrodenitrogenation	(W-Ni) oxides
Chemical Manufacturing	
Natural Gas desulfurization	ZnO, Cu, Fe on activated C
Hydrogenations	Raney Ni, Raney Co, Pt, Rh
Ammonia synthesis	promoted Fe
Methanol synthesis	Cu-ZnO
Dehydrogenation	Butadiene: Fe ₂ O ₃ , Pt/Re on alumina styrene: Zn, Cr, Fe or Mn oxides
Oxidations	ethylene oxide: Ag nitric acid: Pt/Rh mesh/gauze sulfuric acid: V ₂ O ₅ maleic, phthalic anhydrides: V ₂ O ₅ formaldehyde: Ag or Cu; Mo, Fe, V oxides
Polymerizations	Ziegler-Natta polypropylene: Al alkyls + TiCl₃ Dow single site polypropylene: Ti metallocene Phillips -- Cr oxide on silica Polyethylene (low density): peroxides, peresters Polystyrene: benzoyl peroxide Urethanes: amines, organo-tin, phosphine oxides
Hydroformylation	Union Carbide/Hoechst/BASF: Rh/PPh₃ Exxon/BASF: HCo(CO)₄ Shell: HCo(CO)₄(PR₃) (R = bulky alkyl)

Catalytic Production of the Top **Organic** Industrial Chemicals

Ranking	Chemical	Production
#4	Ethylene 33 billion lbs	Steam Cracking of Hydrocarbons: larger hydrocarbon \longrightarrow smaller hydrocarbon + H ₂ $C_2H_6(g) \longrightarrow C_2H_4(g) + H_2(g)$ Catalyst: Zeolites, Pt/Re on Al₂O₃ support Conditions: 850°C, 20-50 atm
#10	Propylene 18 billion lbs	Steam Cracking of Hydrocarbons: $C_3H_8(g) \longrightarrow C_3H_6(g) + C_2H_4(g) + CH_4(g) + H_2(g)$ Catalyst: Zeolites, Pt/Re on Al₂O₃ support Conditions: 850°C, 20-50 atm
#12	Dichloroethane 15 billion lbs	<i>Direct Chlorination:</i> $C_2H_4(g) + Cl_2(g) \longrightarrow ClCH_2CH_2Cl(g)$ Catalyst: FeCl₃ or AlCl₃ <i>Oxychlorination:</i> $2C_2H_4(g) + 4HCl(g) + O_2 \longrightarrow 2ClCH_2CH_2Cl(g) + 2H_2O$ Catalyst: Cu salts on SiO₂ or Al₂O₃ supports
#16	Benzene 10 billion lbs	Hydrocarbon Reforming (dehydrogenation) $C_6H_{14}(g) \longrightarrow C_6H_{12}(g) + H_2(g)$ Endothermic! $C_6H_{12}(g) \longrightarrow C_6H_6(g) + 3H_2(g)$ Endothermic! toluene \longrightarrow benzene + methane Catalyst: Pt/Re/Ge/Sn on Al₂O₃ support
#17	Ethyl Benzene 9 billion lbs	$C_6H_6(g) + C_2H_4(g) \longrightarrow C_6H_5C_2H_5$ 1. Catalyst: Liquid phase system with AlCl₃ 2. Catalyst: Zeolite – Lewis Acid based gas phase process Classic Friedel-Crafts rxn.
#19	Vinyl Chloride 8 billion lbs	$ClCH_2CH_2Cl(g) \longrightarrow H_2C=CHCl(g) + HCl(g)$ This reaction is often coupled with the oxychlorination reaction to produce dichloroethane, this allows recycling of the HCl.
#20	Styrene 8 billion lbs	Dehydrogenation of ethyl benzene Catalyst: Fe oxides on Al₂O₃ support Conditions: 550-600°C
#21	Terephthalic Acid 8 billion lbs	<i>Amoco Process:</i> $p-CH_3-C_6H_4-CH_3 + 3O_2 \longrightarrow p-HOOC-C_6H_4-COOH + H_2O$ Catalyst: Co/Mn salts (with some heavy metal bromides) Conditions: liquid acetic acid solution, 200°C, 20 atm Ti or Hastelloy C lined reactor (very corrosive)

#22	Methanol	$\text{CO} + \text{H}_2 \longrightarrow \text{CH}_3\text{OH}$ <p>Catalyst: ZnO/Cu salt</p> <p>Conditions: > 100 atm, 200-300°C</p>
	7 billion lbs	
#24	Ethylene Oxide	$\text{C}_2\text{H}_4(\text{g}) + \frac{1}{2}\text{O}_2 \longrightarrow \text{ethylene oxide}$ <p>Catalyst: Ag</p> <p>Conditions: 300°C</p>
	6 billion lbs	
#26	Toluene	<p>Catalytic Reforming of methyl cyclohexane and derivatives</p> <p>Catalyst: Pt/Re on Al₂O₃ support</p> <p>Conditions: 500°C and 25 atm</p>
	6 billion lbs	
#27	Xylenes	<p>Catalytic Reforming of 1,4-dimethylcyclohexane</p> <p>Catalyst: Pt/Re on Al₂O₃ support</p> <p>Conditions: 500°C and 25 atm</p>
	5.5 billion lbs	
#28	Ethylene Glycol	$\text{ethylene oxide} + \text{H}_2\text{O} \longrightarrow \text{HOCH}_2\text{CH}_2\text{OH}$ <p>Catalyst: H₂SO₄ (0.5 - 1%), 50°-70°C</p> <p>Conditions: Thermal @ 195°C and 15 atm.</p>
	5 billion lbs	
#29	Butylaldehyde	<p><i>Hydroformylation -- Union Carbide/Celanese/BASF</i></p> $\text{propylene} + \text{H}_2 + \text{CO} \longrightarrow \text{CH}_3\text{CH}_2\text{CH}_2\text{CHO}$ <p>Catalyst: <i>homogeneous Rh/PPh₃ catalyst</i></p> <p>Conditions: 100-125°C, 8-25 atm</p>
	5 billion lbs	
#31	Cummene	$\text{benzene} + \text{propene} \longrightarrow \text{C}_6\text{H}_5\text{CH}(\text{CH}_3)_2$ <p>1. Liquid phase catalysts: H₂SO₄, AlCl₃, HF</p> <p>2. Gas phase catalyst: H₃PO₄ on SiO₂</p> <p>Friedel Crafts reaction</p> <p>Conditions: 35-40°C, 7 bar (liquid); 200-300°C, 20-40 bar (gas)</p> <p>Cumene is mainly used to produce phenol and acetone.</p>
	3.7 billion lbs	
#32	Acetic Acid	$\text{CH}_3\text{OH} + \text{CO} \longrightarrow \text{CH}_3\text{COOH}$ <p>Catalyst: <i>homogeneous RhI₂(CO)₂⁻</i> <i>(Monsanto Acetic Acid process)</i></p> <p>Conditions: 150°C, 35 atm</p>
	3.5 billion lbs	

Homogeneous Catalysis

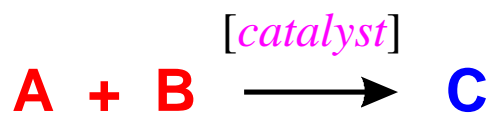

Remember that thermodynamics and equilibrium still rule!! A catalyst only speeds up the rate at which a chemical reaction reaches equilibrium. The actual equilibrium constant (thermodynamics) is NOT affected by the catalyst. Therefore, non-spontaneous reactions are usually NOT suitable for catalytic applications.

Advantages/Disadvantages of **Homogeneous** Catalysts Relative to **Heterogeneous** Catalysts

Good **homogeneous** catalysts are:

- good*
- generally far more selective for a single product
 - far more active
 - far more easily studied from chemical & mechanistic aspects
 - far more easily modified for optimizing selectivity
- bad*
- far more sensitive to permanent deactivation
 - far more difficult for achieving product/catalyst separations

Heterogeneous catalysts dominate chemical and petrochemical industry: ~ 95% of all chemical processes use **heterogeneous** catalysts.

Homogeneous catalysts are used when *selectivity* is critical and product-catalyst *separation problems* can be solved.

Homogeneous or Heterogeneous?

Because many **homogeneous** catalysts decompose to form **heterogeneous** catalysts, and some **heterogeneous** catalysts can dissolve to form **homogeneous** catalysts, one should always be careful about making assumptions on what type of catalyst one is using in any new catalytic experiment. There are several general ways to test whether a catalyst is **homogeneous** or **heterogeneous**.

- 1) Exposure to elemental Hg will generally poison a **heterogeneous** catalyst
- 2) Exposure to polythiols will poison most **homogeneous** catalysts
- 3) Light scattering studies to identify the presence of colloids (**heterogeneous**)
- 4) Product selectivity studies

e.g., polymer bound alkenes:

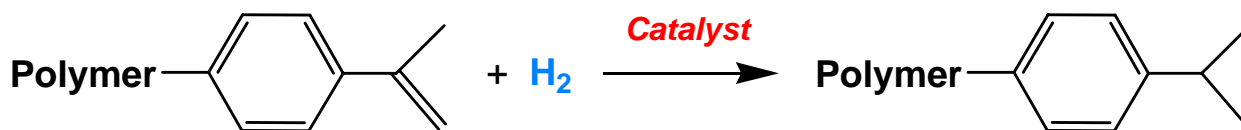

Catalyst	Homo/Hetero	% Yield
RhCl(PPh ₃) ₃	<i>homo</i>	100
Ni(OAc) ₂ + NaBH ₄	<i>hetero</i>	--
[Rh(nbd)(PR ₃) ₂] ⁺	<i>homo</i>	90
Pd/C	<i>hetero</i>	--
[Ir(cod){P(i-pr) ₃ }(py)] ⁺	<i>homo</i>	100

Catalysis Terminology

Turnover (TO) -- one loop through the catalyst cycle. Typically one equivalent of reactant is converted to one equivalent of product (per equivalent of catalyst).

Turnover Frequency (TOF) or Turnover Rate -- the number of passes through the catalytic cycle per unit time (typically sec, min or hrs). This number is usually determined by taking the # of moles of product produced, dividing that by the # of moles of catalyst used in the reaction, then dividing that by the time to produce the given amount of product. The units, therefore, are usually just $time^{-1}$. Note that the rate of a batch catalytic reaction is fastest at the very beginning of when the reactant concentration is the highest and generally slows down as the reaction proceeds -- stopping when all the reactant is used up. Note the graph below for the production of aldehyde product from the homogeneously catalyzed reaction of vinyl acetate, H₂, and CO.

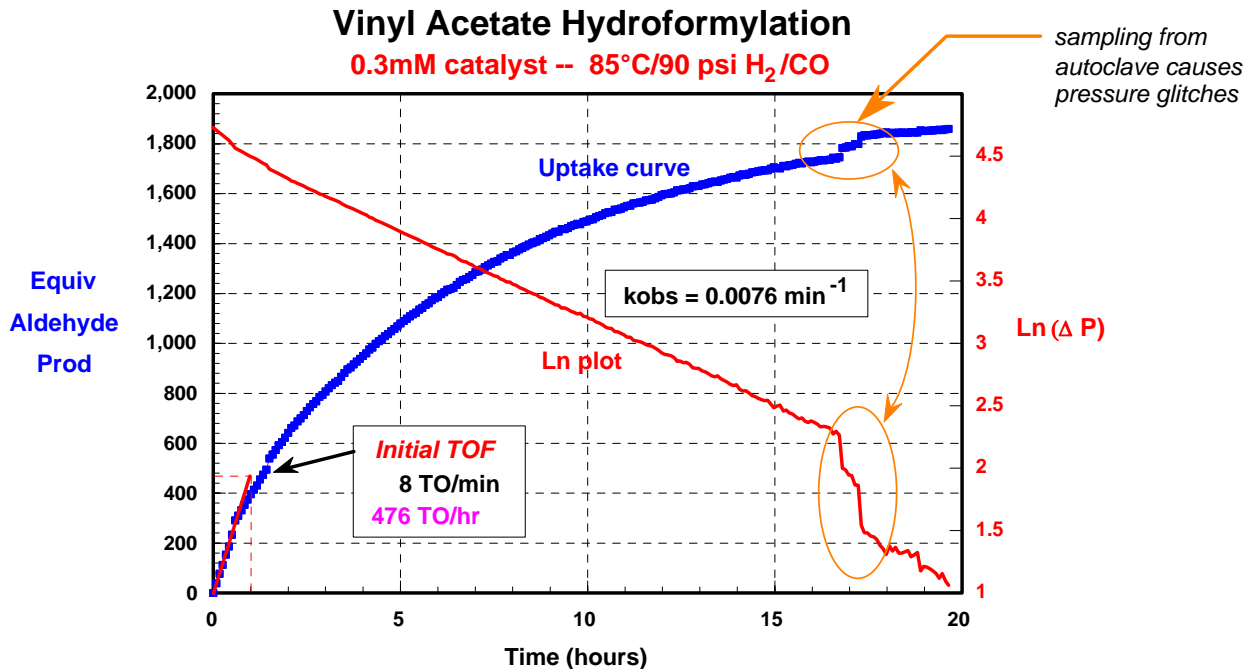

The TOF, therefore, will vary throughout the course of a batch reaction. The **Initial TOF** is defined as the initial part of a catalytic reaction where the rate is the fastest and essentially linear. A far better measure of rate is the observed rate constant k_{obs} , which allows one to reproduce

the entire product production curve given a set of reactant & catalyst concentrations. In the above graph, the reaction is pseudo-first order in excess reactant alkene (vinyl acetate concentration ~ 0.6 M, catalyst 0.3 mM) and k_{obs} is determined from a \ln plot of the change in H_2/CO pressure (reactant concentration) versus time for this rxn. When reporting k_{obs} chemists often normalize it to a certain catalyst concentration (1 mM, for example).

Turnover Number (TON) -- the absolute number of passes through the catalytic cycle before the catalyst becomes deactivated. Academic chemists sometimes report only the turnover number when the catalyst is very slow (they don't want to be embarrassed by reporting a very low TOF), or decomposes quite rapidly. Industrial chemists are interested in both TON and TOF. A large TON (e.g., $10^6 - 10^{10}$) indicates a stable, very long-lived catalyst. TON is defined as the amount of reactant (moles) divided by the amount of catalyst (moles) times the % yield of product. Authors often report mole % of catalyst used. This refers to the amount of catalyst relative to the amount of reactant present. 10 mole % = 10 TO, 1 mole % = 100 TON, 0.01% = 10,000 TON.

ee (enantioselectivity) – this defines the enantioselectivity of an asymmetric catalyst that produces more of one optically active enantiomer (*R* enantiomer, for example) than the other (*S* enantiomer). **ee** is defined as:

$$ee = \frac{|R - S|}{R + S} \times 100\%$$

A catalyst that makes an equal amount of *R* and *S* enantiomers has 0% ee (a racemic mixture). 85% or higher is generally considered a good ee, although that depends on what the best known catalyst can do relative to that being reported.

Catalysis Data in Publications

There is a lot of mediocre catalysis (some bad) reported all the time in chemistry publications. One often has to dig into the data to figure this out. The things one wants to typically look for to tell whether there is “good” catalysis or not include:

- 1) # of turnovers performed – more is better
- 2) TOF (turnover frequency) – faster is better
- 3) Selectivity for product(s) – this includes chemoselectivity, regioselectivity, and enantioselectivity (if applicable)
- 4) Reaction conditions – harsh? Mild? Unusual? Concentrations?

To figure out the number of turnovers you need to know the amount of substrate (reactant) and catalyst:

$$\text{Turnovers} = \frac{\# \text{ moles (equivalents) reactant (substrate)}}{\# \text{ moles (equivalents) catalyst}}$$

But authors often list these values in different ways and you may have to do some interpreting. The most common alternate way of representing the substrate:catalyst ratio is **mole %**. This is especially common for organic chemists doing Pd-catalyzed coupling reactions. 10 mole % catalyst means that there is 10% as much catalyst as substrate on a molar basis. This is equivalent to 10 turnovers.

10 mole % catalyst = 10 turnovers

5 mole % catalyst = 20 turnovers

1 mole % catalyst = 100 turnovers

0.1 mole % catalyst = 1000 turnovers

0.01 mole % catalyst = 10,000 turnovers

These represent the theoretical maximum # of turnovers. One also has to note the % yield or the % conversion of substrate into product to figure out the actual # of turnovers!!

Example: Consider the following catalytic data reported in a *J. Am. Chem. Soc.* communication (supposedly very prestigious) a number of years ago:

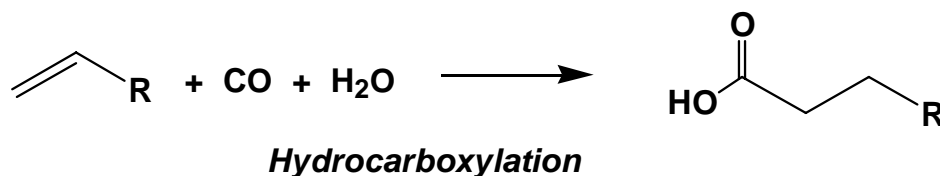

Table I. Hydrocarboxylation of *p*-Isobutylstyrene (**1**) and 2-Vinyl-6-methoxynaphthalene (**2**)

substrate	L*	1 (or 2)/ L*/PdCl ₂	product yield, ^a %	optical yield, ^b %
1	(<i>S</i>)-BNPPA	7.7/0.38/1.0	89	83 (<i>S</i>)
	(<i>S</i>)-BNPPA	7.7/0.77/1.0	80	55 (<i>S</i>)
	(<i>R</i>)-BNPPA	7.7/0.38/1.0	81	84 (<i>R</i>)
2	(<i>S</i>)-BNPPA	4.2/0.42/1.0	46	72 (<i>S</i>)
	(<i>S</i>)-BNPPA	10/0.5/1.0	71	85 (<i>S</i>)
	(<i>R</i>)-BNPPA	4.2/0.42/1.0	48	76 (<i>R</i>)
	(<i>R</i>)-BNPPA	7.7/0.38/1.0	64	91 (<i>R</i>)

^aYield of pure material. ^bDetermined by optical rotation measurements, relative to those for the pure enantiomers, reported in the literature^{9,10} and confirmed by independent measurements of authentic pure *S*-(+) enantiomers in the authors' laboratory.

Let's look at the last line of data from the table since that had the highest ee. The third column contains the important information about the ratio of reactant (often referred to as substrate), chiral chelating ligand L*, and PdCl₂.

The authors had 7.7 equivalents of reactant, 0.38 equivalents of chiral ligand, and 1 equivalent of Pd. This means that the maximum number of turnovers they could do is defined by the amount of reactant (moles or equivalents) divided by the amount of catalyst (moles or equivalents).

$$\text{max turnovers} = \frac{\text{equivalents reactant}}{\text{equivalents catalyst}} = \frac{7.7}{1.0} = 7.7$$

7.7 turnovers is small and not at all impressive. Hydrocarboxylation, however, is a difficult catalytic reaction and doing it asymmetrically is even more impressive.

Of course, 7.7 turnovers assumes 100% yield, which they did not get. The actual number of turnovers needs to be reduced by the % yield, which they report as 64%, so the actual number of turnovers is:

$$\text{actual turnovers} = 7.7 \times 0.64 = 4.9$$

4.9 turnovers is barely catalytic. What about the TOF? Well you have to read a little footnote to find how long they ran the reaction to get their 64% yield: 18 hours at 1 atm of CO. The TOF is the number of turnovers divided by the time:

$$\text{TOF} = \frac{4.9 \text{ turnovers}}{18 \text{ hr}} = 0.27 \text{ hr}^{-1}$$

Well, 0.27 turnovers/hr is also barely catalytic. But that 91% ee is quite impressive isn't it. Or is it?

The authors only added 0.38 equivalents of chiral ligand to 1 eq of PdCl₂ to generate, at most, 0.38 equivalents of chiral catalyst (assuming one ligand per Pd). This is rather unusual, since one usually adds a little excess of chiral ligand to generate a chiral catalyst, even when dealing with a chelating ligand. There are examples where one can add less ligand than metal complex due to the fact that the metal-ligand catalyst generated is much more active than the starting metal complex itself. But one almost always adds enough ligand (or extra since the ligand can dissociate) to generate as much of the presumed catalytically active species as possible.

The ligand that the authors are using is:

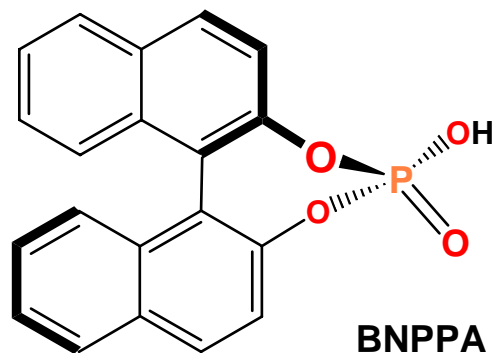

This is being used under rather acidic conditions (typically needed for Pd-catalyzed hydrocarboxylation) and under these conditions it is highly unlikely that it would be able to function as a ligand. Remember that the late transition metals don't particularly like oxygen donor ligands (weaker bonding).

This fact makes the high ee's rather suspect. And a number of research groups (Hoechst Celanese, Union Carbide, etc.) have found (although not published) that the actual ee for this "catalyst" is close to 0.

So it is often important to read the experimental conditions very carefully.

Problem: Consider the following catalytic data reported in a recent publication. What information is missing?

Table 1 Biphasic hydrogenation reactions of arenes in the [bmim][BF₄] ionic liquid and water with [H₄Ru₄(η⁶-C₆H₆)₄][BF₄]₂ as the catalyst precursor

Substrate	Reaction system	Reaction conditions	Con- version (%)	Catalytic turnover ^a / mol mol ⁻¹ h ⁻¹
Benzene	Ionic liquid	60 atm H ₂ , 90 °C, 2.5 h	91	364
	Water	60 atm H ₂ , 90 °C, 2.5 h	88	352
Toluene	Ionic liquid	60 atm H ₂ , 90 °C, 3 h	72	240
	Water	60 atm H ₂ , 90 °C, 3 h	78	261
Cumene	Ionic liquid	60 atm H ₂ , 90 °C, 2.5 h	34	136
	Water	60 atm H ₂ , 90 °C, 2.5 h	31	124

^a Catalytic turnover is calculated on the assumption that the tetra-ruthenium catalyst does not break down into monoruthenium fragments which is entirely consistent with the data.

Notes and references

† The ionic liquid [bmim][BF₄] was prepared using the literature method.⁶ [H₄Ru₄(η⁶-C₆H₆)][BF₄]₂ is very soluble and stable in this ionic liquid and is readily characterised in the ionic liquid using ¹H NMR spectroscopy which revealed a spectrum similar to that in conventional solvents.

Hydrogenations were carried using a Parr stainless steel autoclave (300 ml) fitted with either a glass or PTFE liner. The catalyst [H₄Ru₄(η⁶-C₆H₆)][BF₄]₂ was added together with the required amount of [bmim][BF₄] ionic liquid. The autoclave was then sealed and purged with hydrogen gas (99.9995% purity) and the appropriate reaction pressure was then set at room temperature. The autoclave was then sealed and heated to the required reaction temperature and stirred for the time period required. After reaction the contents were then separated into organic and ionic liquid phases and the products analysed by ¹H NMR spectroscopy and GC. The only products observed were the perhydrogenated cycloalkanes, there was no evidence for the formation of partially hydrogenated products or polymeric by-products.

Problem: Beller and coworkers have reported (*Angew. Chem.*, **2001**, *40*, 3408-3411) on hydroformylation catalysis using HRh(CO)(Naphos). The table of catalytic data from their paper is shown below. For experiment # 1, how many turnovers did the authors do? Clearly show how you calculate your number. Is there any important data missing from this table?

Table 1. Hydroformylation of 1- and 2-pentene with NAPHOS.^[a]

Entry	Olefin	<i>p</i> [bar]	<i>T</i> [°C]	Yield ^[b] [%]	<i>n:i</i>	TOF [h ⁻¹]
1	1-pentene	10	120	76	99:1	475
2	1-pentene	50	120	88	97:3	550
3	2-pentene	10	120	22	89:11	138
4	2-pentene	50	120	7	55:45	44

[a] Reaction conditions: olefin (70.0 mmol; 40 mL solution), [Rh(acac)-(CO)₂] (0.01 mol %; 20.7 ppm Rh), NAPHOS:Rh = 5:1, *t* = 16 h. [b] No significant amounts (> 1 %) of other products apart from isomerized olefin were detected.

Problem: What information is missing from the following Table of catalytic results (they defined the ligands used elsewhere in the paper). How many turnovers are they doing?

Table 1 Asymmetric hydrogenation of methyl α -acetamidocinnamate^a

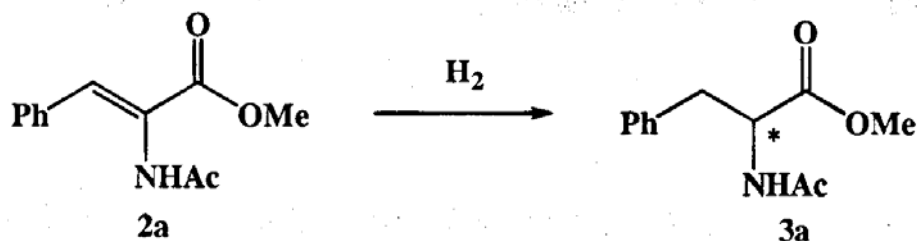

Entry	Ligand	Solvent	Conv.	Ee [%]	t/2 [min]
1	1a	toluene	100	47 (R)	6
2	1b	toluene	100	46 (R)	4
3	1c	toluene	100	20 (R)	52
4	1d	toluene	100	90 (R)	50
5	1e	toluene	100	74 (R)	12
6	1f	toluene	100	82 (R)	36
7	1g	toluene	100	67 (R)	17

^aConditions: 1 mmol substrate; 0.01 mmol [Rh(COD)₂]BF₄; cat.:ligand = 1:2; 15 ml solvent; 25°C

Hydrogenation Catalysis

Hydrogenation is the addition of H₂ to a multiple bond (C=C, C≡C, C=O, C=N, C≡N, N=O, N=N, N≡N, etc) to reduce it to a lower bond order. The most common and simple type of hydrogenation is the reduction of a C=C double bond to a saturated alkane:

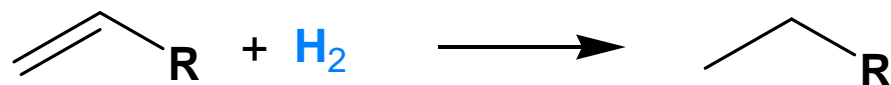

There are three different ways that transition metal catalysts can activate H₂ for performing hydrogenation catalysis:

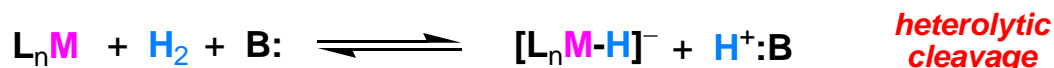
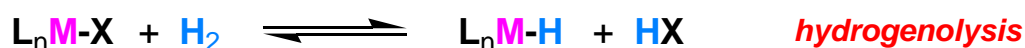
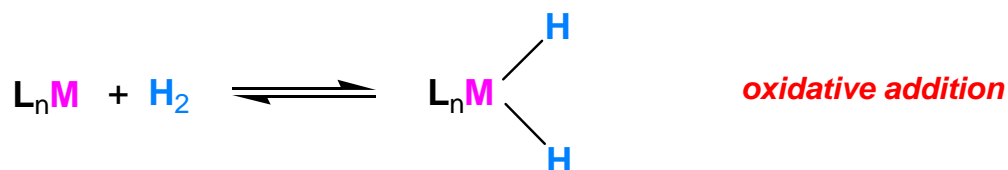

Oxidative addition: the most common method of activating H₂ on a metal with d electrons (d² or higher). Metal center typically needs to have an empty coordination site in order to bind the H₂ first, prior to the oxidative addition.

Hydrogenolysis: the only way that early transition metals with d⁰ counts can activate H₂. Lanthanides and actinides also typically use hydrogenolysis. As with oxidative addition, the metal center needs to have an empty orbital to bind the H₂ and an anionic ligand (e.g., alkyl, halide) that can be protonated off. No change in oxidation state of the metal.

Heterolytic cleavage: in many ways quite similar to hydrogenolysis except that the proton produced does not directly react with an anionic ligand coordinated to the metal, but rather with an external base that typically has to transfer it back to the metal center to complete the catalytic cycle. Ru(+2) is the most common metal that uses heterolytic cleavage as a mechanism. No change in oxidation state of the metal.

Wilkinson's Catalyst: $\text{RhCl}(\text{PPh}_3)_3$ was the first highly active homogeneous hydrogenation catalyst and was discovered by Geoffrey Wilkinson (Nobel prize winner for Ferrocene) in 1964. R. Coffey discovered it at about the same time while working for ICI (Imperial Chemical Industries). It was very simply prepared by reacting $\text{RhCl}_3 \cdot 3\text{H}_2\text{O}$ with excess PPh_3 in EtOH:



The proposed mechanism is as follows:

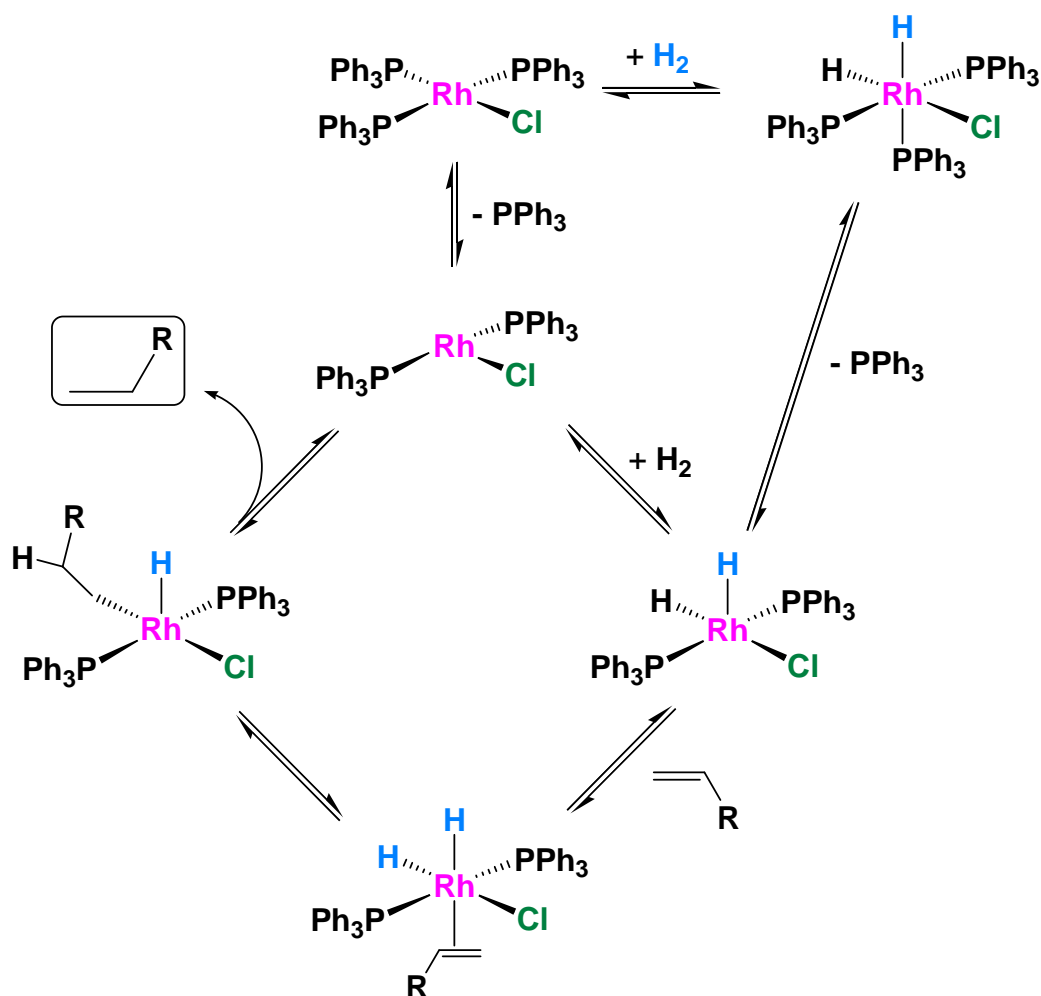

It has been clearly shown that PPh_3 is readily lost due to steric crowding and that the inner catalytic cycle with a weakly coordinated solvent molecule (not shown) is about 1000 times faster than the outer cycle that has 3 PPh_3 ligands coordinated to the metal.

Selectivity:

Hydrogenation catalysts typically will selectively hydrogenate the most reactive multiple bonds first. Steric and electronic effects play an important role in this. Consider the following examples:

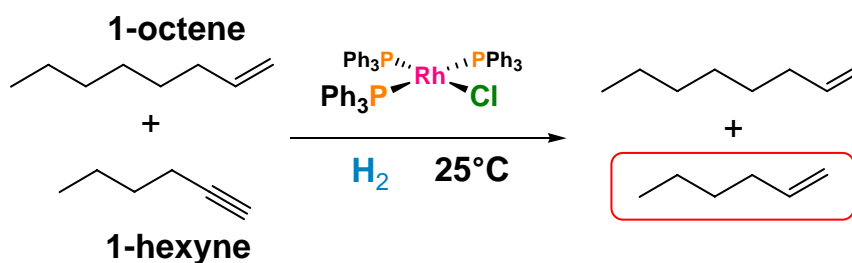
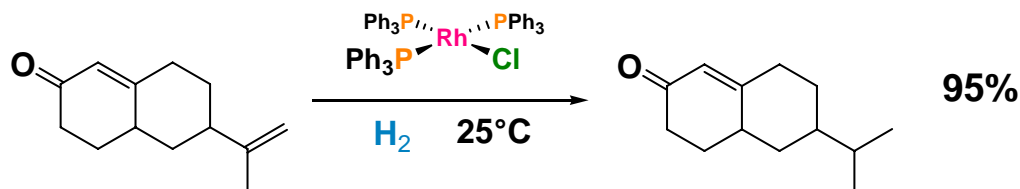

Typically NOT hydrogenated under mild conditions:

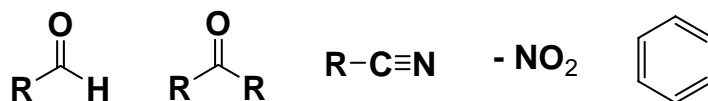

Problem: In the molecule below, which of the olefins (A, B, or C) would you expect to hydrogenate faster and why?

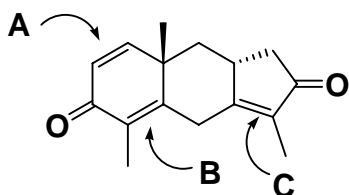

Directing Effects

Crabtree has demonstrated some very interesting substrate directing effects in hydrogenation:

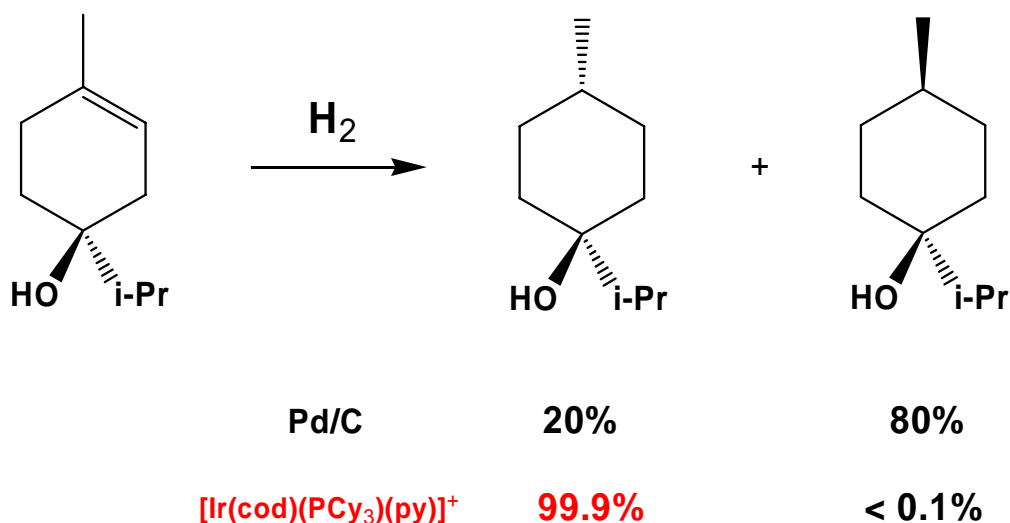

The weak ligand bonding of the OH group on the substrate directs one specific side of the alkene to coordinate to the metal center in order to form an alkene-OH chelate to the Ir.

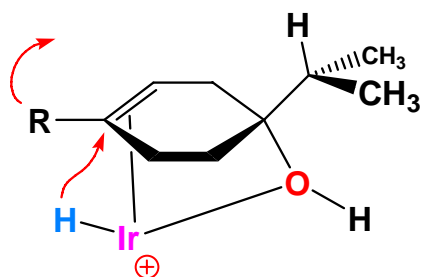

positive charge on Ir is important to attract the partial negatively charged OH group. One also needs the presence of an empty orbital

Group binding affinities: **amide > OH > OR > ester ~ ketone**

Amine groups bind too strongly and inhibit catalysis. Rigid structures with stronger chelates, like the norbornene ligand shown to the right, are also poor substrates.

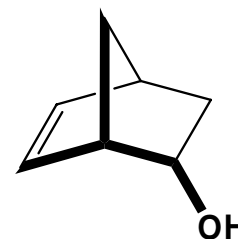

For a comprehensive review of cyclic and acyclic substrate-directed hydrogenations see: Hoveyda, Evans, and Fu, *Chem. Rev.* **1993**, 93, 1307.

Asymmetric Hydrogenation

95% of all hydrogenations use heterogeneous catalysts like Pd on carbon (Pd/C) or Raney Nickel. One area where homogeneous catalysis rules is *asymmetric hydrogenation*. This involves the use of a chiral catalyst and an alkene substrate that generates a chiral carbon center on hydrogenation.

The first dramatic example of this was reported in 1968 by Bill Knowles and coworkers at Monsanto. Knowles found that a bidentate, C_2 symmetric version of the cationic Schrock-Osborn catalyst afforded extraordinarily high levels of enantioselectivity in the hydrogenation of α -acetamidocinnamic acid which is used to produce **L-Dopa**, an important pharmaceutical for the treatment of Parkinson's disease (Knowles, *JACS* **1975**, *97*, 2567). Knowles went on to win the Nobel Prize in 2001, sharing it with B. Sharpless and R. Noyori, for this discovery.

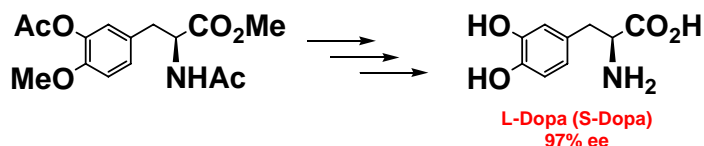

Halpern *Science* **1982**, *217*, 401

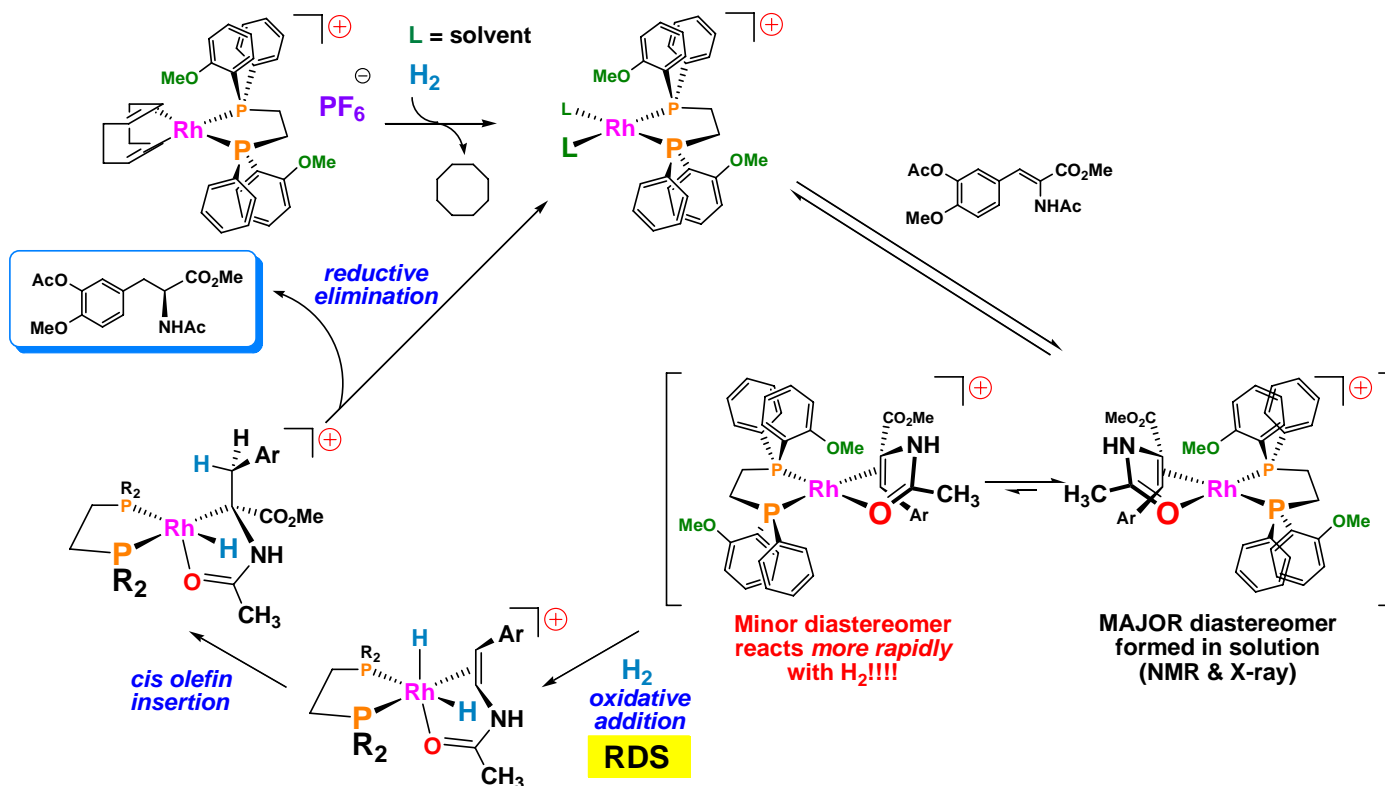

As you can see, the mechanism of this hydrogenation differs from that observed with neutral catalyst ligated with monodentate ligands. That is, olefin complexation occurs *prior* to H₂ oxidative addition and this oxidative addition is the rate-limiting step. What is even more amazing is that the major olefin complex diastereomer, which was isolated and characterized by NMR and X-ray techniques, gives the WRONG product. In elegant mechanistic studies, Halpern showed that the *minor diastereomer* (olefin complex) **REACTS 580x FASTER** to give the final hydrogenated chiral product in a 60:1 ratio!

Problem: Draw a reaction coordinate diagram that clearly shows the difference in reactivity between the two diastereotopic olefin complexes.

Ru Heterolytic H₂ Activation

Ru has a strong tendency to perform a *heterolytic activation of H₂* instead of oxidative addition to make a metal dihydride. This can occur either via hydrogenolysis or heterolytic cleavage mechanisms.

Complexation of the dihydrogen to the metal leads to a *decrease* in H-H σ -bond character. This decrease in bonding leaves it with a partial positive charge hence making it more *acidic*, or easier to deprotonate with a 'base' (either internal or external). Both hydrogenolysis (σ bond metathesis) and heterolytic cleavage mechanism give the same net result:

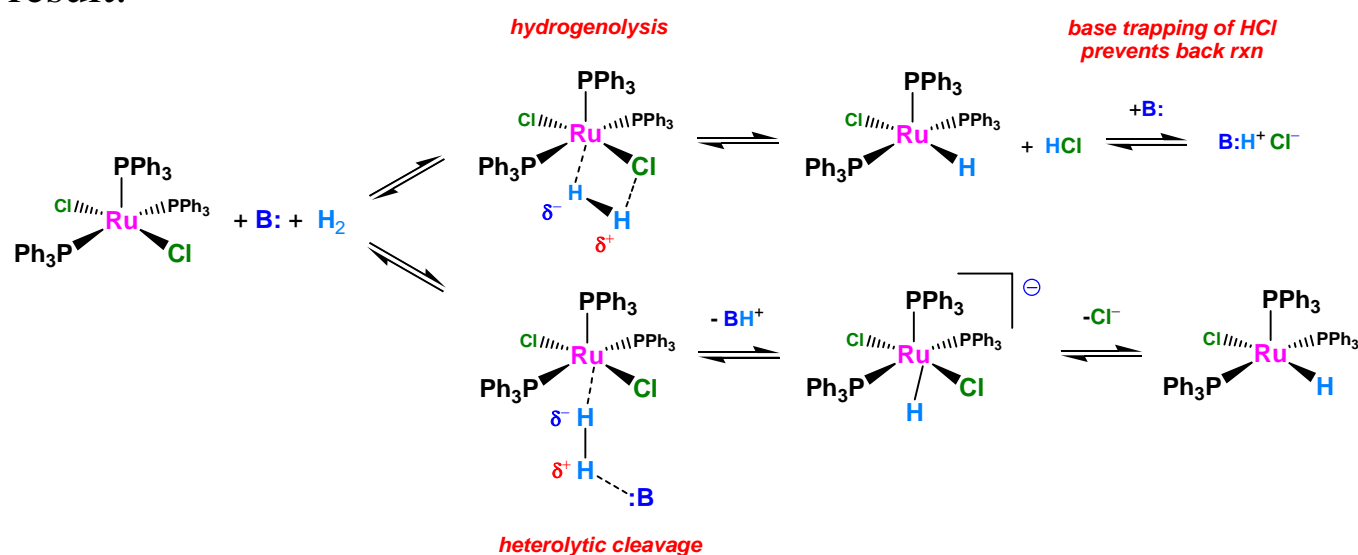

Shown below is a proposed catalytic cycle for Ru(+2) catalyzed hydrogenation:

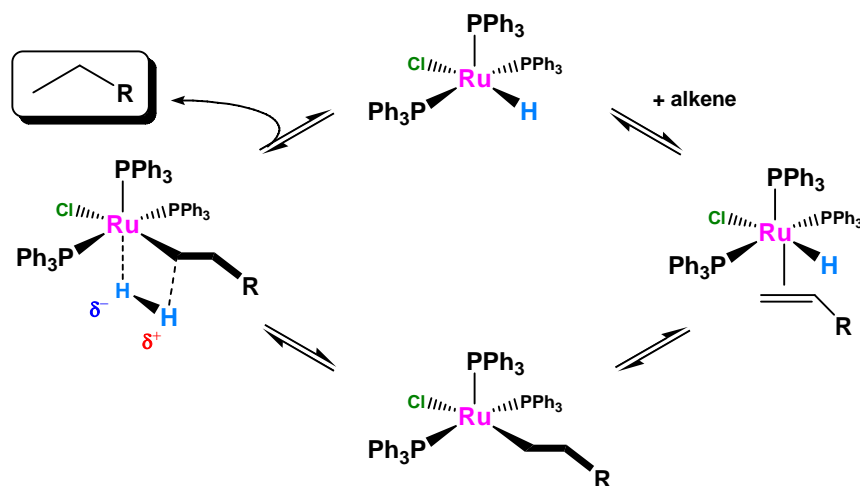

Note that there is no change in oxidation state of the Ru(+2)!

Lanthanide Hydrogenation Catalysts

Tobin Marks reported the extraordinary activity of $(\text{Cp}^*_2\text{LuH})_2$ for the hydrogenation of alkenes and alkynes. The monometallic complex catalyzes the hydrogenation of 1-hexene with a TOF = 120,000 hr^{-1} at 1 atm H_2 , 25°C!! This is one of the most active hydrogenation catalysts known.

The proposed mechanism is shown below:

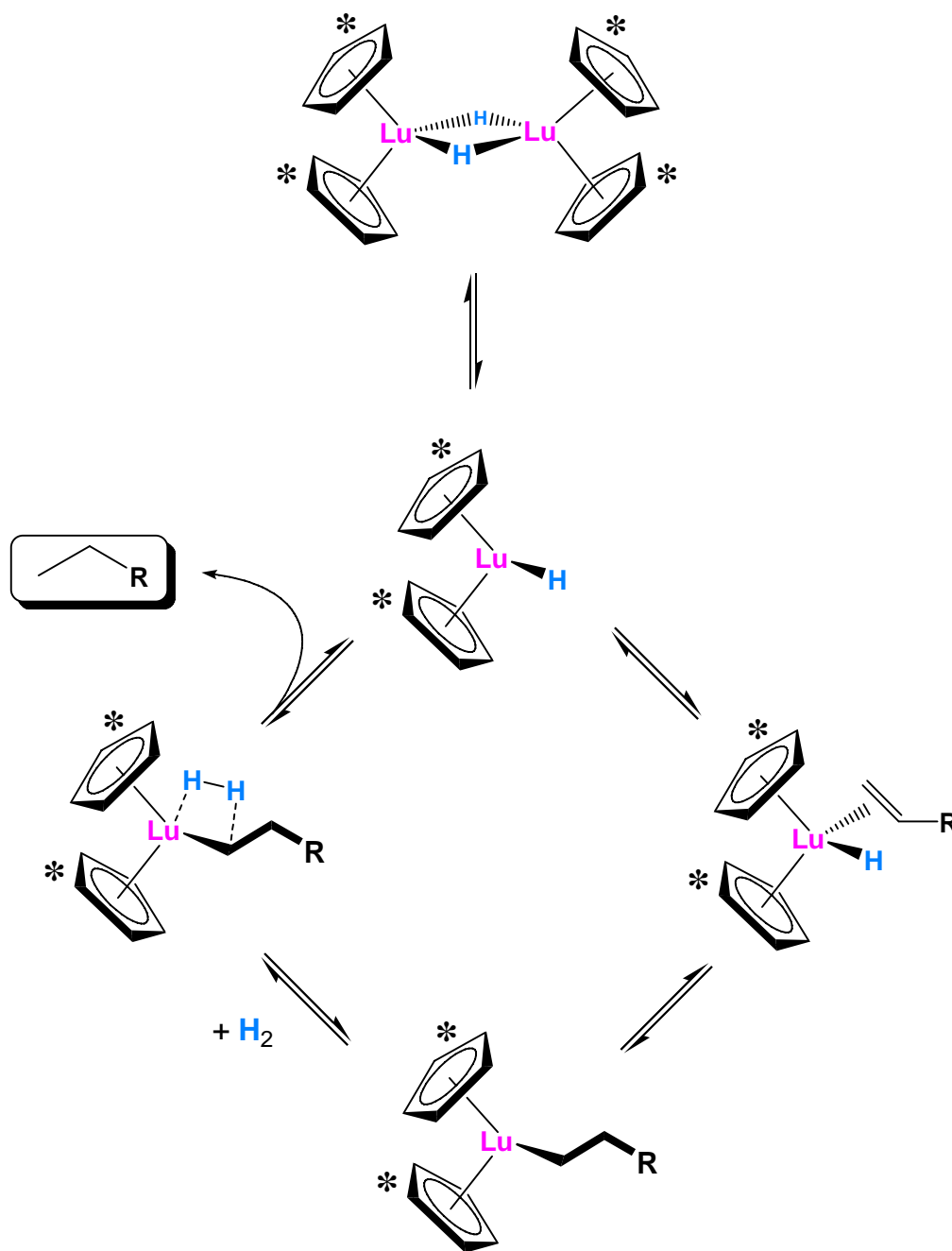

Other H-X additions: Hydrosilylation and Hydrocyanation

Hydrosilylation (addition of H-SiR₃)

These H-X additions are very similar to hydrogenation (addition of H-X where X=H). Platinum and Palladium catalysts are most widely used for the hydrosilylation of alkenes.

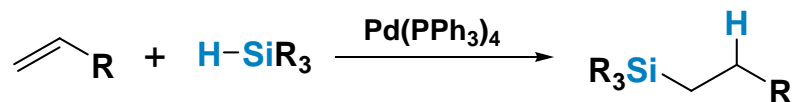

Hydrosilylation of alkynes has been achieved with rhodium and ruthenium catalysts.

Parish *JOMC* 1978, 161, 91

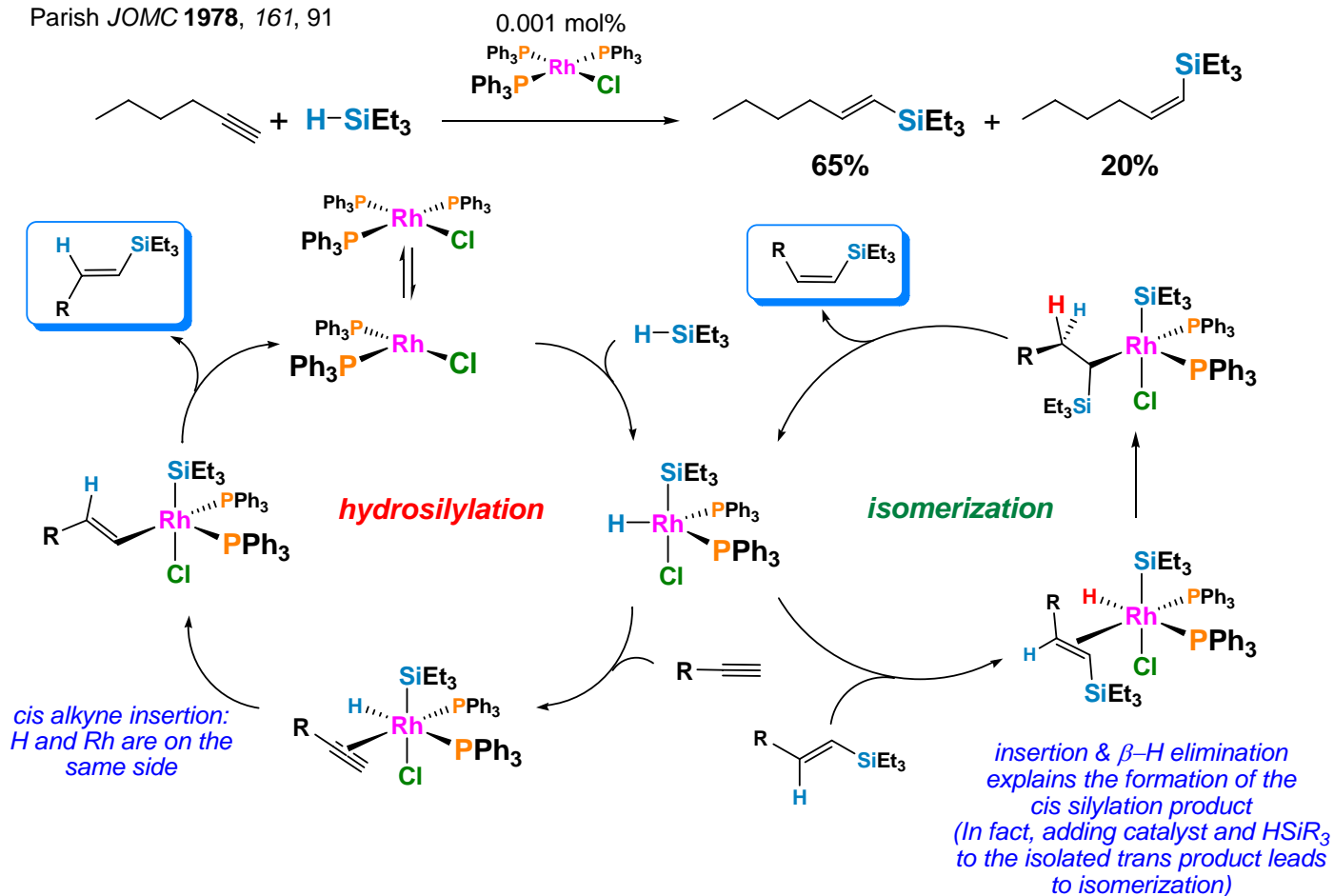

Hydrocyanation (addition of H-CN)

Hydrocyanation is used industrially to prepare adiponitrile from butadiene. Adiponitrile is the key intermediate in synthesizing Nylon-6,6.

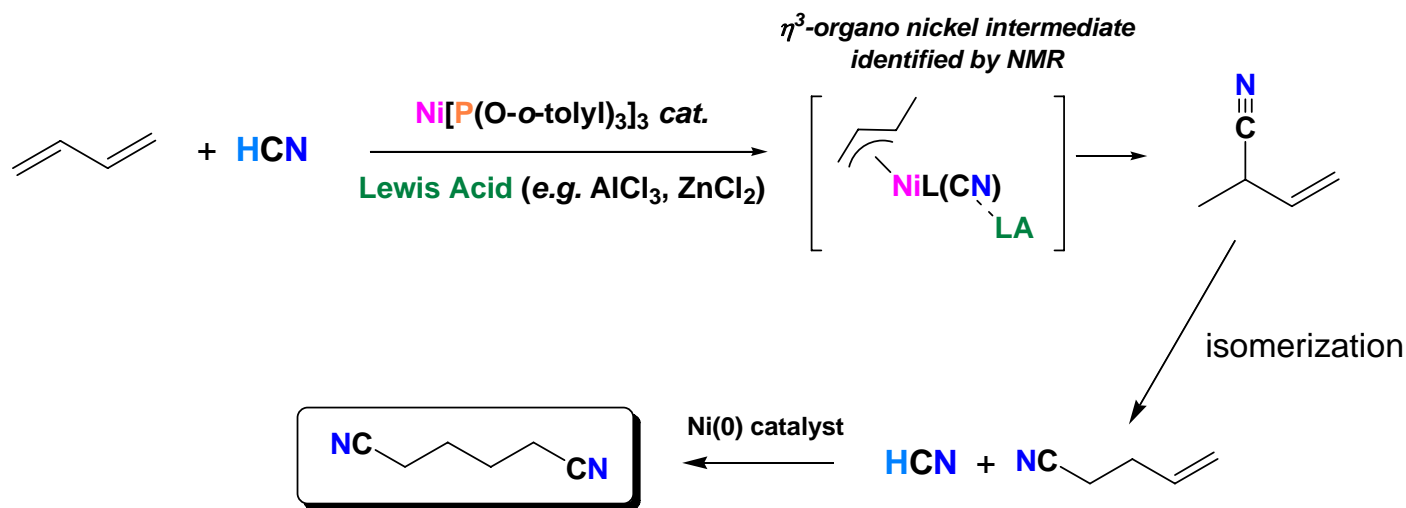

Problem: Draw a detailed reaction mechanism that shows the conversion of butadiene to adiponitrile.

Hydroformylation (Oxo) Catalysis

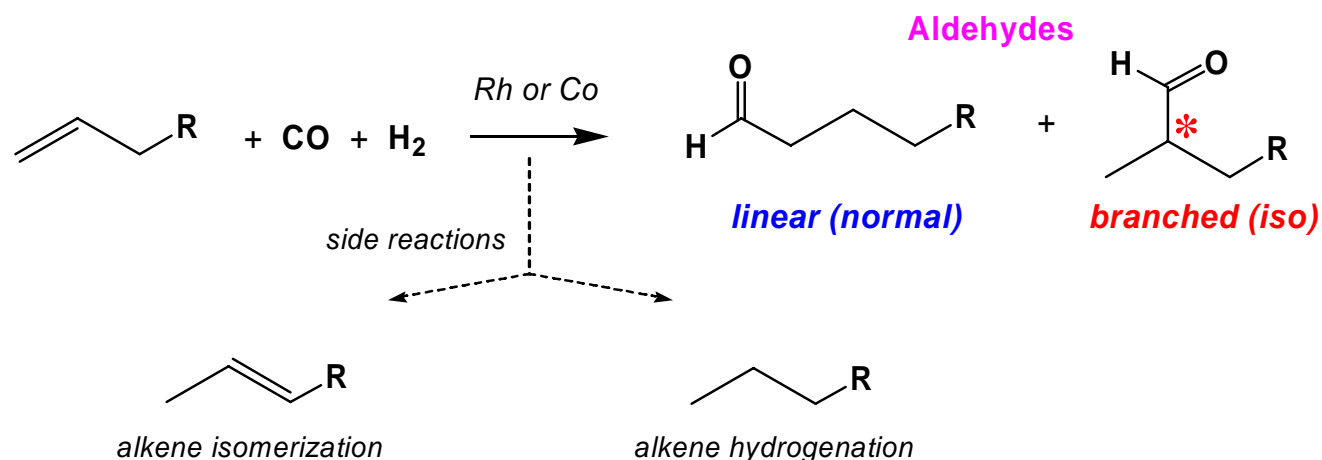

- * **Largest homogeneous catalytic process**
- * **> 15 billion pounds of aldehydes (alcohols) per year**
- * **Commercial catalysts are complexes of Co or Rh**
- * **Selectivity to linear (normal) or branched (iso) products is important**

Hydroformylation was discovered by Otto Roelen in 1938 during an investigation of the origin of oxygenated products occurring in cobalt catalyzed Fischer-Tropsch reactions. Roelen's observation that ethylene, H₂ and CO were converted into propanal, and at higher pressures, diethyl ketone, marked the beginning of hydroformylation.

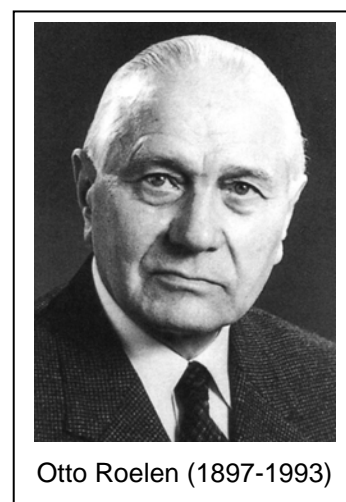

Cobalt catalysts completely dominated industrial hydroformylation until the early 1970's when rhodium catalysts were commercialized. In 2004, ~75% of all hydroformylation processes are based on rhodium triarylphosphine catalysts, which excel with C₈ or lower alkenes and where high regioselectivity to linear aldehydes is critical.

Most aldehydes produced are hydrogenated to alcohols or oxidized to carboxylic acids. Esterification of the alcohols with phthalic anhydride produces dialkyl phthalate plasticizers that are primarily used for polyvinyl chloride plastics -- the

largest single end-use. Detergents and surfactants make up the next largest category, followed by solvents, lubricants and chemical intermediates.

HCo(CO)₄ Catalyst. Roelen's original research into hydroformylation involved the use of cobalt salts that, under H₂/CO pressure, produced HCo(CO)₄ as the active catalyst. In 1960 and 1961 Heck and Breslow^{1,2} proposed what is now accepted as the general mechanism for hydroformylation:

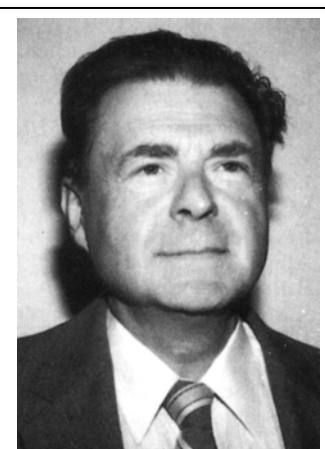

Richard Heck (b. 1931)

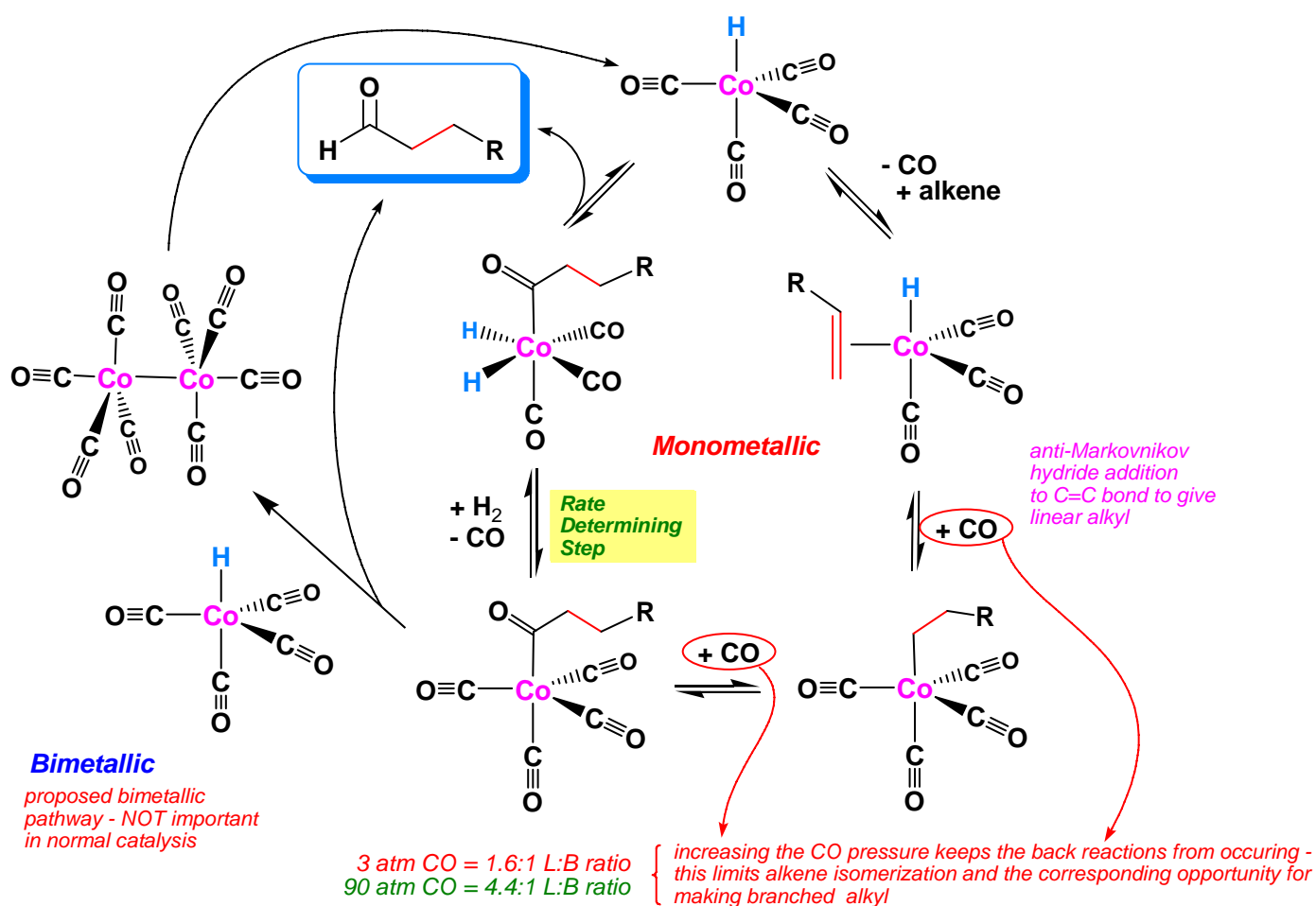

An alternate bimetallic pathway was also suggested, but not favored, by Heck and Breslow. The acyl intermediate could react with $\text{HCo}(\text{CO})_4$ to do an *intermolecular* hydride transfer, followed by reductive elimination of aldehyde producing the Co-Co bonded dimer $\text{Co}_2(\text{CO})_8$. A common starting material for $\text{HCo}(\text{CO})_4$ catalyzed hydroformylation, $\text{Co}_2(\text{CO})_8$ is well known to react with H_2 under catalysis reaction conditions to form two equivalents of $\text{HCo}(\text{CO})_4$.

The bimetallic hydride transfer mechanism is operational for stoichiometric hydroformylation with $\text{HCo}(\text{CO})_4$ and has been proposed to be a possibility for slower catalytic hydroformylation reactions with internal alkenes.³ The mono-metallic pathway involving reaction of the acyl intermediate with H_2 , however, has been repeatedly shown to be the dominant mechanism for 1-alkenes and cyclohexane.^{4,5}

$$\frac{d(\text{aldehyde})}{dt} = k[\text{alkene}][\text{Co}][\text{H}_2][\text{CO}]^{-1}$$

Kinetic studies support the $\text{HCo}(\text{CO})_4$ mechanism with a general rate expression given above. The inverse dependence on CO pressure is consistent with the mechanistic requirement for CO dissociation from the various saturated 18e species to open up a coordination site for alkene or H_2 binding. When using a 1:1 ratio of H_2/CO , the reaction rate is essentially independent of pressure due to the opposing orders of H_2 and CO. Increasing the H_2/CO ratio is of limited use for increasing the overall reaction rate because $\text{HCo}(\text{CO})_4$ is only stable under certain minimum CO partial pressures at a given temperature.

The reaction conditions for $\text{HCo}(\text{CO})_4$ hydroformylation are largely governed by the thermal instability of $\text{HCo}(\text{CO})_4$, which produces metallic cobalt if the CO partial pressure is **not** kept high enough. As the reaction temperature is increased, the CO partial pressure required to maintain the stability of $\text{HCo}(\text{CO})_4$ increases in a logarithmic fashion (Fig. 1). Thus, the temps needed for reasonable reaction rates (110-180° C) require rather high CO partial, and hence, total H_2/CO pressures of 200-300 bar.

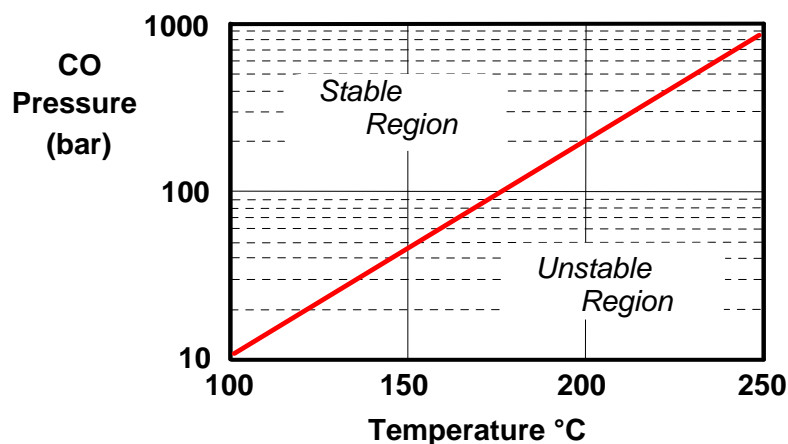
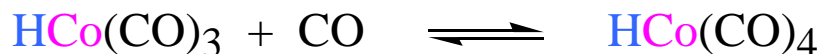
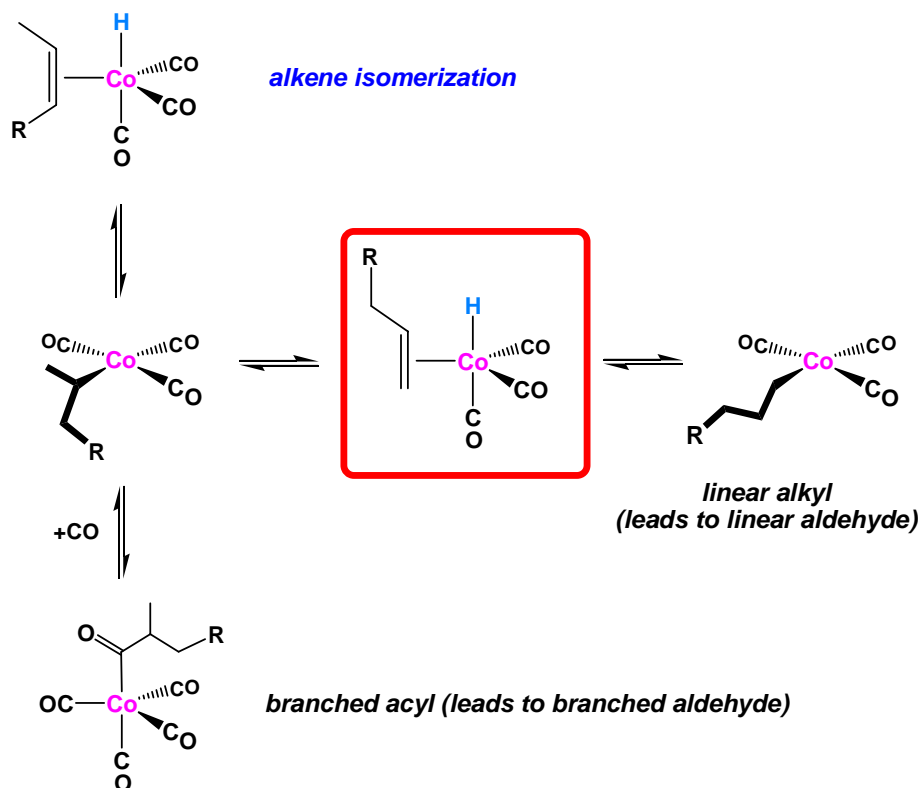

Figure 1. Stability of $\text{HCo}(\text{CO})_4/\text{Co}_2(\text{CO})_8$ species with respect to precipitation of cobalt metal (cobalt concentration is 0.4 wt. %).

Increasing the CO partial pressure *decreases* the hydroformylation reaction rate and the amount of alkene isomerization side reactions, while *increasing* the aldehyde linear to branched product ratio. Pino proposed that the apparent marked difference between $\text{HCo}(\text{CO})_4$ catalyzed hydroformylation at low and high CO partial pressures was due to the existence of two active catalyst species, $\text{HCo}(\text{CO})_4$ and $\text{HCo}(\text{CO})_3$, formed from the CO association/dissociation equilibrium:



But the active catalyst is most likely the 16e- $\text{HCo}(\text{CO})_3$ complex. The low probability of direct alkene reaction with the 18e- saturated $\text{HCo}(\text{CO})_4$ catalyst is consistent with the reduced activity at higher CO partial pressures. One can also explain the lower regioselectivity at lower CO pressure by proposing that alkene isomerization is more facile with the resulting 16e- $\text{RCo}(\text{CO})_3$ species that results after reaction with alkene as shown below:



Under lower CO partial pressures an unsaturated 16e- $\text{RCo}(\text{CO})_3$ will have a long enough lifetime to allow reverse β -hydride elimination

and increase the possibility for alkene reinsertion to the branched alkyl species, which is slightly more favored thermodynamically. At this point CO addition and insertion will yield a branched aldehyde, or another β -hydride elimination can give alkene isomerization. This second mechanistic explanation is in line with more recent results from Rh/PPh₃ catalyzed hydroformylation studies.

The regioselectivity of HCo(CO)₄ (or HCo(CO)₃) for producing the more valuable linear aldehydes varies with reaction conditions and alkene substrates used. With 1-alkenes one can typically get linear to branched aldehyde ratios of 3-4 to 1. There is a trade-off between rate and regioselectivity. High CO partial pressure slows the rate of catalysis, but increases the linear to branched aldehyde product ratio. Higher CO partial pressures also lower alkene isomerization side reactions. Higher temperatures increase the reaction rate, but lower the linear aldehyde product regioselectivity and increase various undesirable side reactions. Some aldehyde hydrogenation to alcohols is usually observed (5-12%), although alkene hydrogenation is usually quite low (~ 1%), particularly under higher CO partial pressures. Aldehyde hydrogenation is *not* considered to be a negative side reaction because the aldehyde products are usually hydrogenated to alcohols in a later reaction step. The aldehyde hydrogenation, however, consumes additional H₂, so H₂/CO ratios greater than 1:1 are used (1-1.5:1 is common).

High linear product regioselectivity is not, however, the major concern for most HCo(CO)₄ catalyzed industrial plants. What is now Exxon Chemical Co. built the first United States hydroformylation plant in 1948 in Baton Rouge, LA using the high pressure HCo(CO)₄ technology confiscated from the Germans after WWII. This plant produced over 540 million lbs of alcohols each year, and a new plant came on line in 1994 which pushed the capacity to over 800 million lbs of alcohols a year. Exxon uses propylene dimerization/oligomerization to produce a C₇ to C₁₂ mixture of branched internal alkenes. This branched, internal alkene mixture is then hydroformylated and

hydrogenated to a C₈ to C₁₃ alcohol mixture. The alkene isomerization ability of HCo(CO)₄ is quite important in this situation. HCo(CO)₄ under the proper reaction conditions is good at isomerizing double bonds to essentially all possible locations. This can be clearly seen from the data shown below that shows the % of aldehyde formed at each site for the HCo(CO)₄ catalyzed hydroformylation of 1-octene and 4-octene (150° C/200 bar 1/1 H₂/CO).⁶

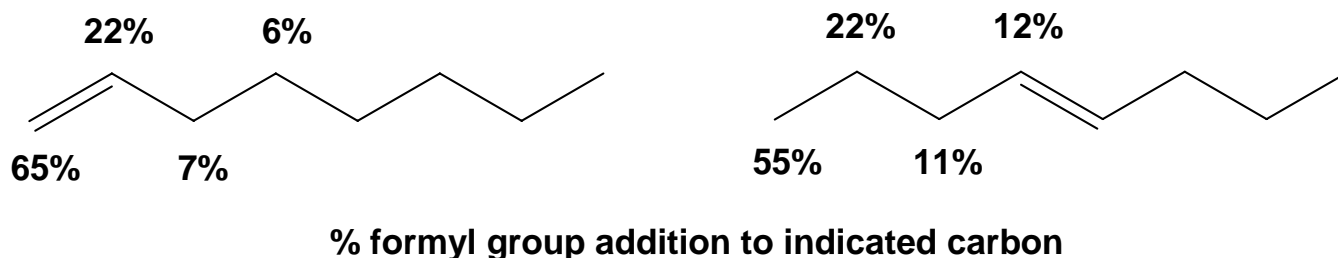

Under these conditions, the linear to branched aldehyde ratio for the hydroformylation of 1-octene was 1.9:1. Starting with 4-octene one still gets a 1.2:1 linear to branched ratio. Thus, one can start with a considerably less expensive mixture of terminal and internal alkenes and get a product distribution favoring the linear aldehyde. The product distribution above can be nicely explained by invoking facile alkene isomerization with the fastest hydroformylation occurring for double bonds in the 1-position. Labeling studies have shown that alkene isomerization generally occurs without dissociation of the alkene from the cobalt catalyst.⁷

Alkene branching has a large effect on isomerization and hydroformylation. In a study of various methylheptenes, Haymore found that there was very little hydroformylation at the carbon center with the branch, even if it was part of the double bond. Data for two methylheptenes and % of aldehyde formed at each site is shown below.⁸ Note that isomerization past the branching carbon is not a dominant reaction. Once again, terminal aldehydes are favored.

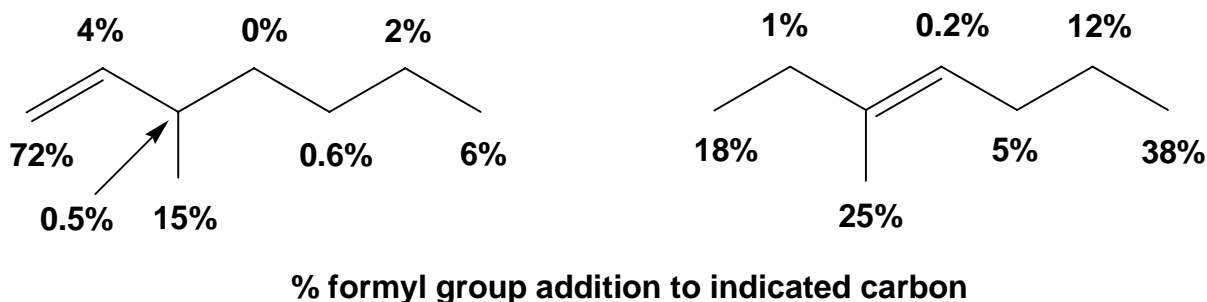

Side reactions of the product aldehydes to form heavier products generally occur, particularly at higher reaction temperatures, and usually account for ~ 9% of the product distribution. Aldol condensations, aldols, trimerizations, and Guerbet dimerizations of product alcohols are some of the more common ways to form heavy byproducts. These side reactions occur to various extents for all long term hydroformylations (Co or Rh). Although industrial reactors are usually started with high boiling solvents, after a while these heavy “ends” become the main solvent system for the reaction.

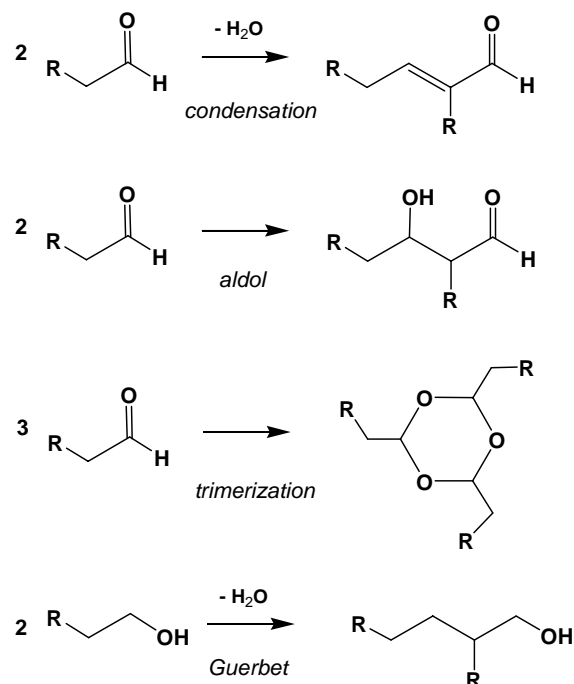

One advantage of the $\text{HCo}(\text{CO})_4$ technology is that catalyst separation and recycling is well established. BASF oxidizes $\text{HCo}(\text{CO})_4$ with O_2 to form water soluble Co^{2+} salts that are extracted from the product stream. These Co^{2+} salts are recycled and reduced under H_2/CO to reform $\text{HCo}(\text{CO})_4$. Exxon uses aqueous NaOH to deprotonate $\text{HCo}(\text{CO})_4$ after catalysis to make $\text{Na}[\text{Co}(\text{CO})_4]$, which is extracted into an aqueous stream. The active $\text{HCo}(\text{CO})_4$ catalyst is regenerated via use of H_2SO_4 and H_2/CO .

Cobalt Phosphine-Modified Catalysts. The only variation on $\text{HCo}(\text{CO})_4$ hydroformylation catalysis involved research at Shell by Slaugh and Mullineaux in which the addition of trialkylphosphine ligands caused a dramatic change in the rate and regioselectivity.⁹ The electronic effect of substituting an electron donating alkylated phosphine for one of the carbonyl ligands to produce $\text{HCo}(\text{CO})_3(\text{PR}_3)$, results in stronger Co-CO bonding. This causes a dramatic reduction in the CO partial pressures required to stabilize the catalyst and prevent formation of Co metal. Instead of 200-300 bars of H_2/CO pressure needed for $\text{HCo}(\text{CO})_4$, the monophosphine substituted $\text{HCo}(\text{CO})_3(\text{PR}_3)$ only needed 50-100 bars of pressure, and could be run at higher temperatures without any decomposition of catalyst to cobalt metal.

Another electronic effect is that the electron-donating phosphine increases the hydridic nature of the hydride ligand ($\text{HCo}(\text{CO})_4$ is quite acidic) and dramatically increases the hydrogenation capabilities of the $\text{HCo}(\text{CO})_3(\text{PR}_3)$ catalyst. This means that the aldehydes produced are subsequently hydrogenated by $\text{HCo}(\text{CO})_3(\text{PR}_3)$ to make alcohols. Less e-rich phosphines, such as PPh_3 , give less hydrogenation to alcohol, and lower linear regioselectivities. The better hydrogenation ability, however, also results in increased alkene hydrogenation side-reactions producing alkanes that can range from 10-20% of the product distribution (depending on the phosphine and rxn conditions). Because of the aldehyde hydrogenation step more H_2 is needed, so H_2/CO ratios of 2:1 (or slightly higher) are typically used. The proposed hydroformylation and hydrogenation mechanisms are both shown below.

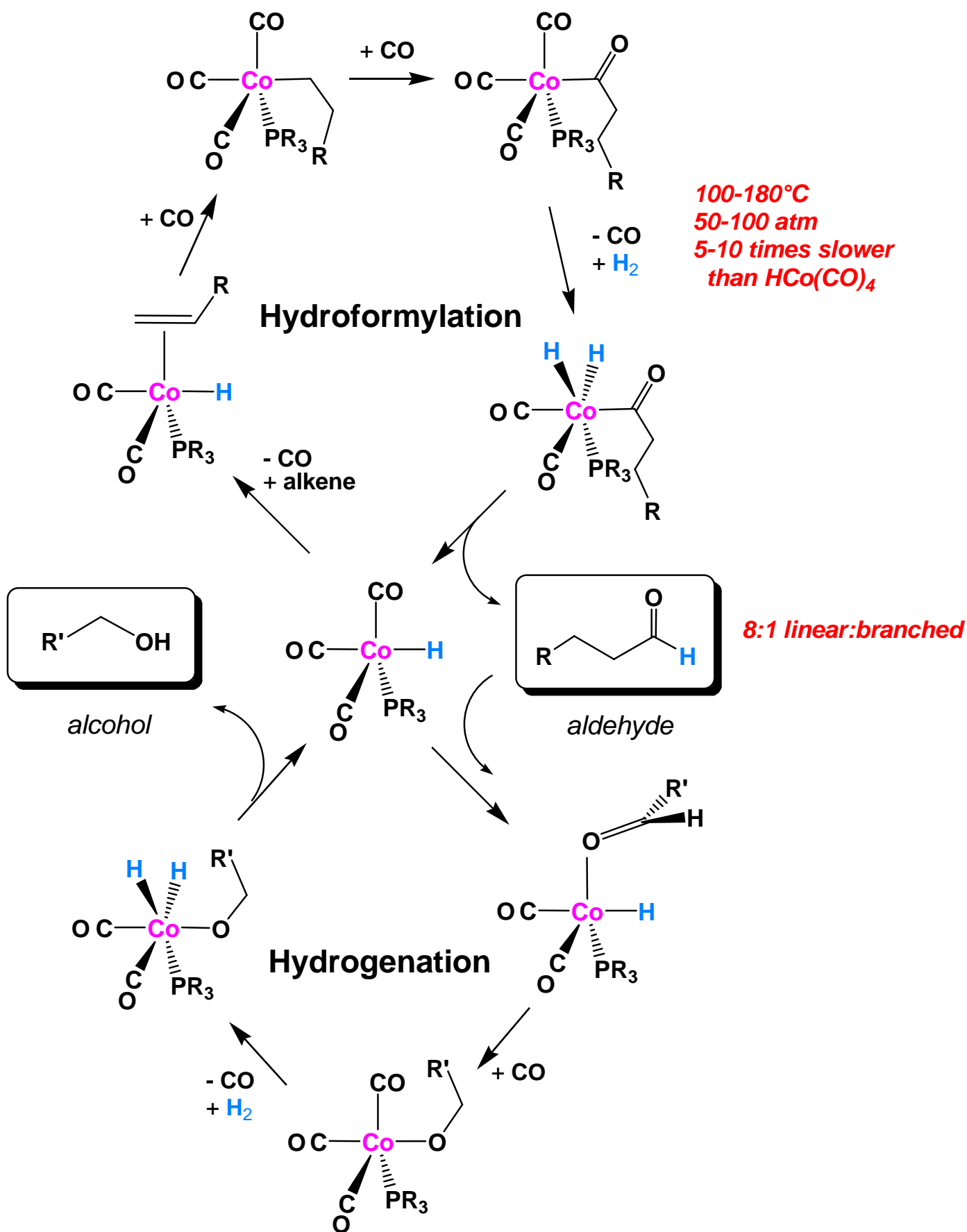

The final electronic effect of phosphine substitution is that the higher stability of the $\text{HCo}(\text{CO})_3(\text{PR}_3)$ catalyst, due to stronger Co-CO bonding, means that this catalyst is less active than $\text{HCo}(\text{CO})_4$ (about 5-10 times slower). Just as with the unmodified cobalt catalyst, CO dissociation from the saturated 18e- species is needed to open up an empty coordination site on the cobalt to allow coordination of alkene and H_2 . Higher reaction temperatures, therefore, are used in conjunction with longer reaction times and larger reactor volumes.

From a steric viewpoint the bulkier trialkylphosphine ligand favors formation of linear products. While linear to branched ratios of only 2-3:1 are typically found for $\text{HCo}(\text{CO})_4$, higher regioselectivities of 7-8:1 occur for $\text{HCo}(\text{CO})_3(\text{PR}_3)$. There is a phosphine cone angle cutoff at about 132° , after which the phosphine ligand's steric effects do not increase the product linear regioselectivity any further.

Table 1. Hydroformylation of 1-hexene using $\text{Co}_2(\text{CO})_8/2\text{P}$ as catalyst precursor. 160°C , 70 atm, 1.2:1 H_2/CO

PR_3	pK_a	Tolman ν (cm^{-1})	Cone Angle $^\circ$	$k_f \times 10^3$ (min^{-1})	% Linear Prod	Aldehyde to alcohol
$\text{P}(i\text{-Pr})_3$	9.4	2059.2	160	2.8	85.0	--
PEt_3	8.7	2061.7	132	2.7	89.6	0.9
PPr_3	8.6	2060.9	132	3.1	89.5	1.0
PBU_3	8.4	2060.3	136	3.3	89.6	1.1
PEt_2Ph	6.3	2063.7	136	5.5	84.6	2.2
PEtPh_2	4.9	2066.7	140	8.8	71.7	4.3
PPh_3	2.7	2068.9	145	14.1	62.4	11.7

Phosphine modified cobalt hydroformylation is only used by Shell. It is tightly coupled to *Shell's Higher Olefins Process* (SHOP) that produces a C_4 through C_{20} blend of linear, internal alkenes for hydroformylation to detergent grade alcohols. Exact details of Shell's commercial process have never been published. For example, the specific trialkylphosphine used is not widely known outside of Shell. They do NOT use PBU_3 as it is too volatile.

Rhodium Phosphine Catalysts. In 1965 Osborn, Young and Wilkinson reported that Rh(I)-PPh₃ complexes were active and highly regioselective hydroformylation catalysts for 1-alkenes, even at ambient conditions. Although Slaugh and Mullineaux had filed a patent in 1961 that mentioned Rh/phosphine combinations for hydroformylation, it was Wilkinson's work that really ignited serious interest in rhodium phosphine hydroformylation catalysts. The initial catalyst system was derived from Wilkinson's catalyst, RhCl(PPh₃)₃, but it was rapidly discovered that halides were inhibitors for hydroformylation. It was best, therefore, to start with halide-free rhodium starting complexes. HRh(CO)(PPh₃)₃ and Rh(acac)(CO)₂ (acac = acetoacetate) are two commonly used starting materials for hydroformylation. The currently accepted mechanism for Rh/PPh₃ hydroformylation is shown below. The steps are directly analogous to Heck's mechanism for HCo(CO)₄.

Rh/PPh₃ Hydroformylation Cycle

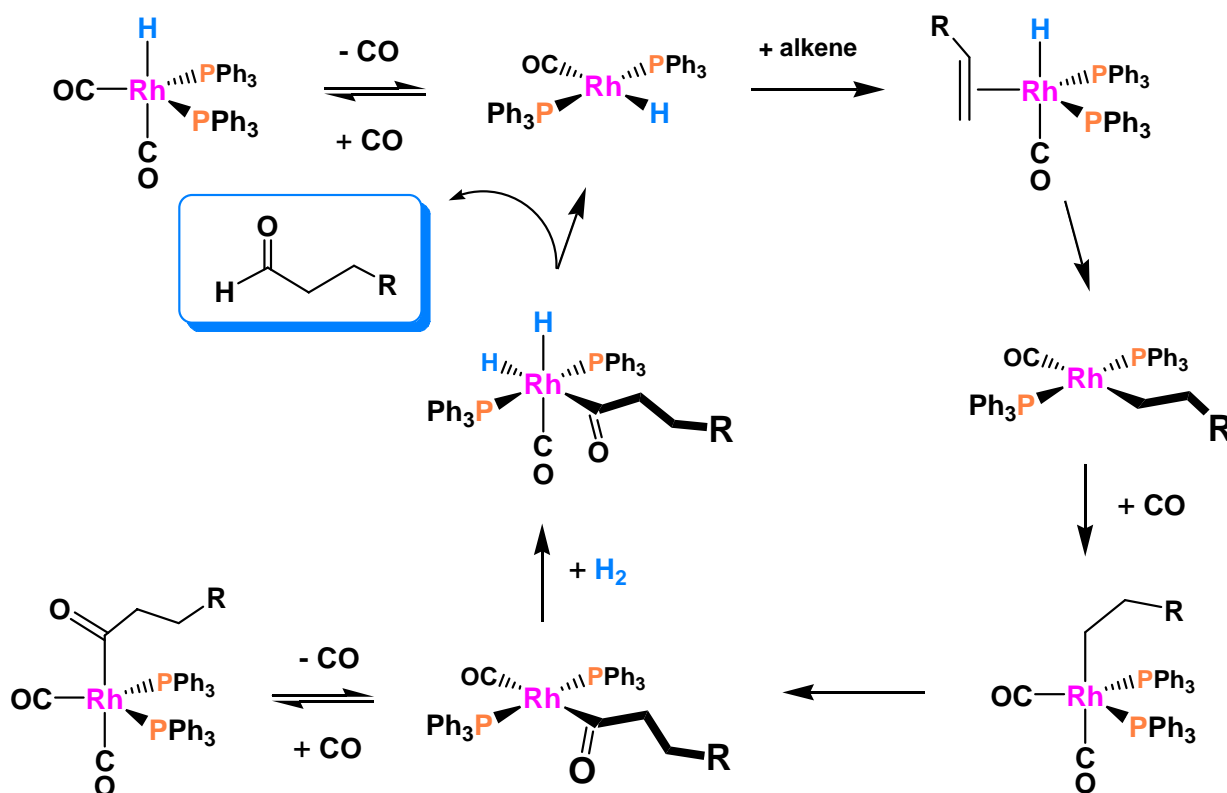

Wilkinson noted that HRh(CO)(PPh₃)₂ was very selective to aldehyde products (no alcohol formation, no alkene hydrogenation or

isomerization) and that very high linear to branched aldehyde selectivities of 20:1 for a variety of 1-alkenes could be obtained under ambient conditions (25° C, 1 bar 1:1 H₂/CO). At higher temperatures, the rate increased, but the regioselectivity dropped (9:1 at 50° C). Running under 80-100 bars of H₂/CO decreased the linear to branched aldehyde selectivity to only 3:1.

Pruett (at Union Carbide) quickly provided the next critical discovery that, along with the work of Booth and coworkers at Union Oil, allowed commercialization of the HRh(CO)(PPh₃)₂ technology. They found that the use of rhodium with excess phosphine ligand created an active, selective, and stable catalyst system at 80-100 psig and 90° C.¹⁰ Union Carbide, in conjunction with Davy Powergas and Johnson Matthey, subsequently developed the first commercial hydroformylation process using rhodium and excess PPh₃ in the early 1970's. The need for excess phosphine arises from the facile Rh-PPh₃ dissociation equilibrium shown below. Loss of PPh₃ from HRh(CO)(PPh₃)₂ generates considerably more active, but *less* regioselective hydroformylation catalysts. The addition of excess phosphine ligand shifts the phosphine dissociation equilibrium back towards the more selective HRh(CO)(PPh₃)₂ catalyst. This explains why higher CO partial pressures lower the product regioselectivity, in marked contrast to what is observed for HCo(CO)₄-catalyzed hydroformylation.

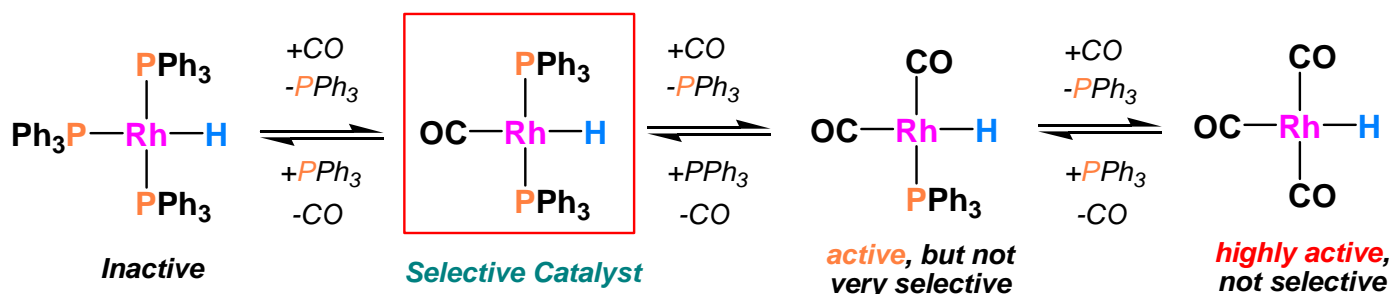

The regioselectivity of $\text{HRh}(\text{CO})(\text{PPh}_3)_2$ is strongly related to the concentration of PPh_3 in solution (up to a certain point) and the H_2/CO ratio used. Commercial hydroformylation reactions are run using solutions that have PPh_3 concentrations of 0.3 M or higher (typical Rh concentration around 1 mM). This corresponds to PPh_3 weight percentages of 8-50% of the total solution in commercial reactors. The effect of PPh_3 concentration on the rate and selectivity for the hydroformylation of 1-hexene can be seen in Table 2.

Table 2. Rate constants and Regioselectivities for the Hydroformylation of 1-Hexene using $\text{Rh}(\text{acac})(\text{CO})_2$ with Different PPh_3 Concentrations. Reaction Conditions: 90 psig (6.2 bar), 1:1 H_2/CO , 90° C.

[Rh] (mM)	[PPh ₃] (M)	PPh ₃ /Rh ratio	k_{obs} (min ⁻¹ mM Rh ⁻¹)	l:b ratio
0.5	0.41	820	0.032	11
1	0.82	820	0.016	17

Note that doubling the PPh_3 concentration cuts the rate constant in half, even though the rhodium concentration was also doubled! The selectivity, on the other hand, increases to 17:1 for the C₇ aldehyde linear to branched ratio. The "ultimate" experiment of running $\text{HRh}(\text{CO})(\text{PPh}_3)_2$ in molten PPh_3 has been done with propylene giving a 16:1 linear to branched aldehyde ratio. Commercially, propylene is run with PPh_3 concentrations around 0.4 M with a catalyst concentration of about 1 mM (400 fold excess of PPh_3), which gives a linear to branched selectivity of ~8-9:1. Lower CO partial pressures also would be expected to favor higher regioselectivities, and this is indeed the case. Rh/ PPh_3 reactions are often run with an excess of hydrogen (2:1 H_2/CO ratios are common). Too high a hydrogen partial pressure, or too low a CO partial pressure, however, will increase the alkene hydrogenation and isomerization side reactions to an unacceptable level.

The rate determining step in Rh/ PPh_3 not fully understood. It was assumed early on in analogy to the $\text{HCo}(\text{CO})_4$ catalyst system, that the rate determining step was H_2 addition to the Rh(I)-acyl species. This has been disputed by several

authors in more recent studies. Kastrup and coworkers concluded from ^{31}P NMR studies that the rate determining step could be the initial coordination of alkene to the $\text{HRh}(\text{CO})(\text{PPh}_3)_2$ catalyst species.¹¹ Moser and coworkers, in a similar vein, proposed that the rate determining step is CO dissociation from $\text{HRh}(\text{CO})_2(\text{PPh}_3)_2$ to once again generate the 16e species $\text{HRh}(\text{CO})(\text{PPh}_3)_2$.¹² Combining both of these proposals, Unruh concluded that several of the fundamental steps in Rh/ PPh_3 hydroformylation appear to have similar rate constants, making it difficult to specify one overall rate determining step, as they may probably vary with the exact reaction conditions. The complexity of the phosphine/CO ligand dissociation/association processes and the many catalytically active rhodium complexes present was most clearly pointed out by Tolman and Faller who presented a 3-dimensional mechanistic scheme for the hydroformylation of alkenes by Rh/ PPh_3 complexes.¹³ The mechanism shown here only indicates the core catalytic cycle that is believed to give the highest product aldehyde regioselectivity.

The other important reason for adding excess phosphine ligand is to minimize ligand fragmentation reactions that lead to catalyst deactivation. If a 14e, highly unsaturated species such as $\text{HRh}(\text{CO})(\text{PPh}_3)$ is formed the very electrophilic metal center can attack the PPh_3 ligand (either intra- or intermolecularly). This leads to cleavage of the P-Ph bond and formation of either alkyldiphenyl phosphines or, in the worst case, phosphide-bridged dimers which are inactive for hydroformylation:

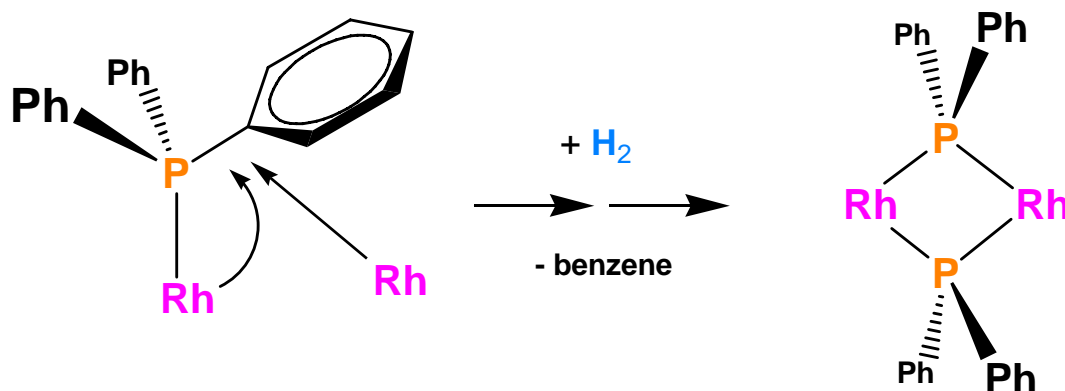

This fragmentation process has been studied and proceeds by oxidative addition of the P-Ph bond to an unsaturated Rh center.^{14, 15} A separate PPh_3 activation process involving ortho-metallation of the phenyl group can also occur. Triarylphosphine ligands and phosphite ligands are particularly susceptible to this fragmentation because of the availability of π - or lone-pair

electron density on the ligands that can interact with an empty Rh orbital. The fact that they are moderate to poor electron-donating ligands also enhances the electrophilicity of the rhodium center.¹⁶ Trialkylphosphine ligands should be relatively inert to these types of Rh-induced fragmentations due to the lack of any π -electron density on the ligand. The considerably stronger σ -donation ability of alkylated phosphines also works to decrease the electrophilicity of the rhodium center. Unfortunately, trialkylphosphine ligands usually dramatically lower both the rate and selectivity of rhodium hydroformylation catalysts.

Chelating phosphines have interesting effects on hydroformylation. $R_2P(CH_2)_xPR_2$ ($x = 2-4$) ligands with alkyl or aryl substituents generally form terrible catalysts that give poor rates and selectivities, as well as extensive alkene isomerization and hydrogenation side reactions. Tridentate tripodal phosphine ligands, such as $MeC(CH_2PPh_2)_3$, also generate catalysts with very poor rates and regioselectivities.¹⁷ High pressure NMR studies have shown that an arm-on, arm-off equilibrium is operational to generate the active unsaturated 16e- catalyst species $HRh(CO)(\eta^2-MeC(CH_2PPh_2)_3)$.¹⁸

Matsumoto and Tamura (at Kuraray Co.) have demonstrated that the combination of simple bis(diphenylphosphino)alkane ligands and PPh_3 can have a very positive effect on catalyst stability and the reduction of unwanted side reactions.¹⁹ This is most evident in the hydroformylation of a reactive alkene such as allyl alcohol. The use of $HRh(CO)(PPh_3)_2$ in the presence of excess PPh_3 leads to relatively rapid catalyst deactivation to unidentified species. The addition of just over 1 equivalent of $Ph_2PCH_2CH_2CH_2CH_2PPh_2$ (dppb) leads to a stable, active hydroformylation catalyst.²⁰ Use of dppb either by itself, or in quantities higher than 2 equivalents, leads to catalyst deactivation and/or poor activities and selectivities. ARCO Chemical licensed the Kuraray technology to build the first plant in 1990 for the hydroformylation of allyl alcohol to produce 1,4-butanediol:

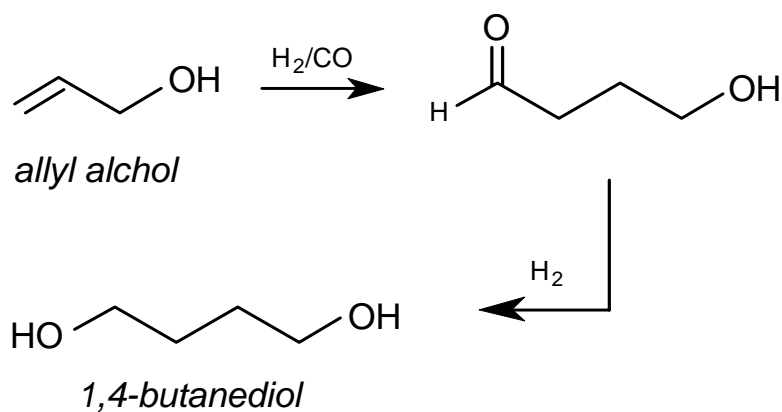

It is not exactly understood how the mixed ligand Rh/dppb/ PPh_3 catalyst system functions. Matsumoto proposed that the arm-on, arm-off equilibrium shown below is operational. A species such as (2) would function much like a normal $\text{HRh}(\text{CO})(\text{PPh}_3)_2$ catalyst, but the ability to reform the chelate to form a slightly more electron-rich complex (3) would tend to inhibit alkene isomerization and/or degradation reactions which require 16e⁻ unsaturated species.

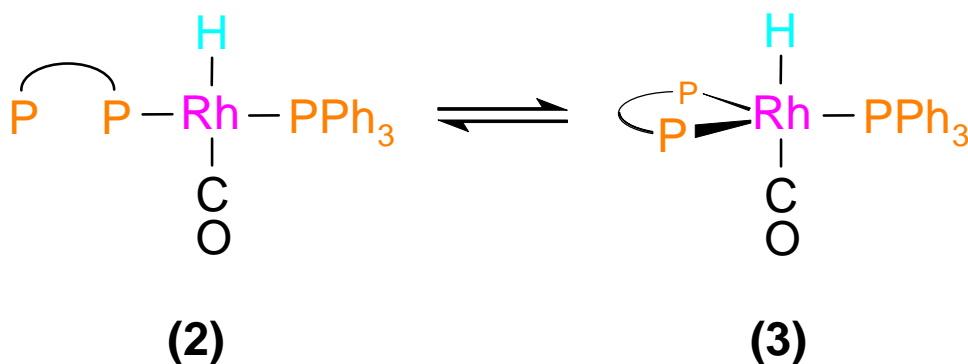

Aqueous-Phase Rh Hydroformylation

One important variant of Rh/PPh₃ catalysis is the water-soluble catalyst system developed by Emile Kuntz at Rhone-Poulenc in 1981. By using a sulfonated PPh₃ ligand, P(Ph-*m*-SO₃⁻ Na⁺)₃ (TPPTS), a highly water soluble catalyst is generated: HRh(CO)[P(Ph-*m*-SO₃⁻ Na⁺)₃]₃. In aqueous solution the catalyst essentially has a -9 charge, making it totally *insoluble* in all but the most polar organic solvents. Excess phosphine ligand is required for good L:B selectivities, as with conventional Rh/PPh₃ catalysts, but lower concentrations are required because the TPPTS phosphine dissociation equilibrium in water is shifted towards the Rh-phosphine coordinated complexes.

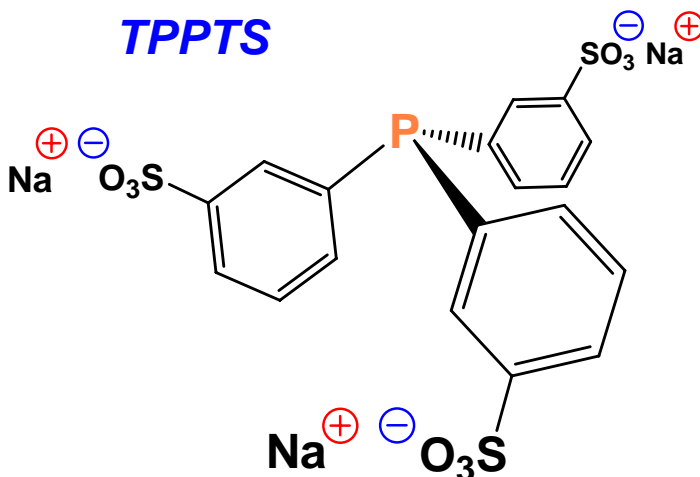

Shorter chain alkenes (C₂-C₄) are water soluble enough that migration into the aqueous catalyst phase occurs to allow hydroformylation. Remigration of the aldehyde product back into the more soluble organic phase allows easy separation of product from catalyst. Rather high linear to branched regioselectivities of 16-18:1 for propylene can be obtained via this water soluble catalyst. Rates are slower than with conventional Rh/PPh₃ catalysts due to lower alkene concentrations in the water phase and higher amounts of the inactive tris-phosphine Rh complex. The process is limited to the shorter chain alkenes that have some appreciable water solubility. Alkenes higher than 1-pentene are not soluble enough in water. Celanese-Ruhrchemie currently operates several hydroformylation plants based on this water soluble rhodium catalyst technology.

2-ethyl-1-hexanol Product

Rh/PPh₃ catalyzed hydroformylation is responsible for just over 50% of all oxo alcohols produced. Propylene is the largest single alkene hydroformylated to produce butylaldehyde, which can be hydrogenated to produce butanol, or dimerized by an aldol condensation and then hydrogenated to form 2-ethyl-1-hexanol (2EH), the largest single product produced by hydroformylation (over 5 billion lbs a year). 2-ethyl-1-hexanol is usually reacted with phthalic anhydride to produce dialkyl phthalic esters that are used as plasticizers to keep polyvinyl chloride plastics soft and flexible.

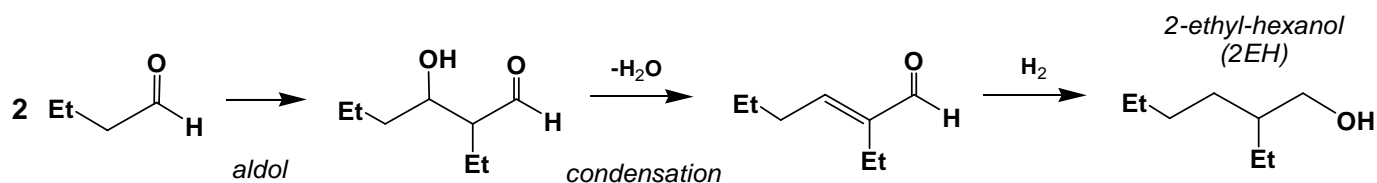

New Generation Rh Catalysts. Union Carbide (now Dow), Eastman Chemical, and Prof. Piet van Leeuwen (University of Amsterdam) have independently developed a new generation of chelating bisphosphine rhodium catalysts that show remarkably high product regioselectivities and good to high activities.

Two of the best Eastman bisphosphine ligands, developed by Devon, Phillips, Puckette and coworkers are called BISBI and BISBI* that form 9-membered chelate rings with the Rh center. Rh catalysts based on these phosphines are highly regioselective, giving linear to branched (L:B) aldehyde product ratios for propylene of > 30:1 (commercial Rh/PPh₃ catalysts give around an 8:1 ratio) with rates about twice that of Rh/PPh₃.

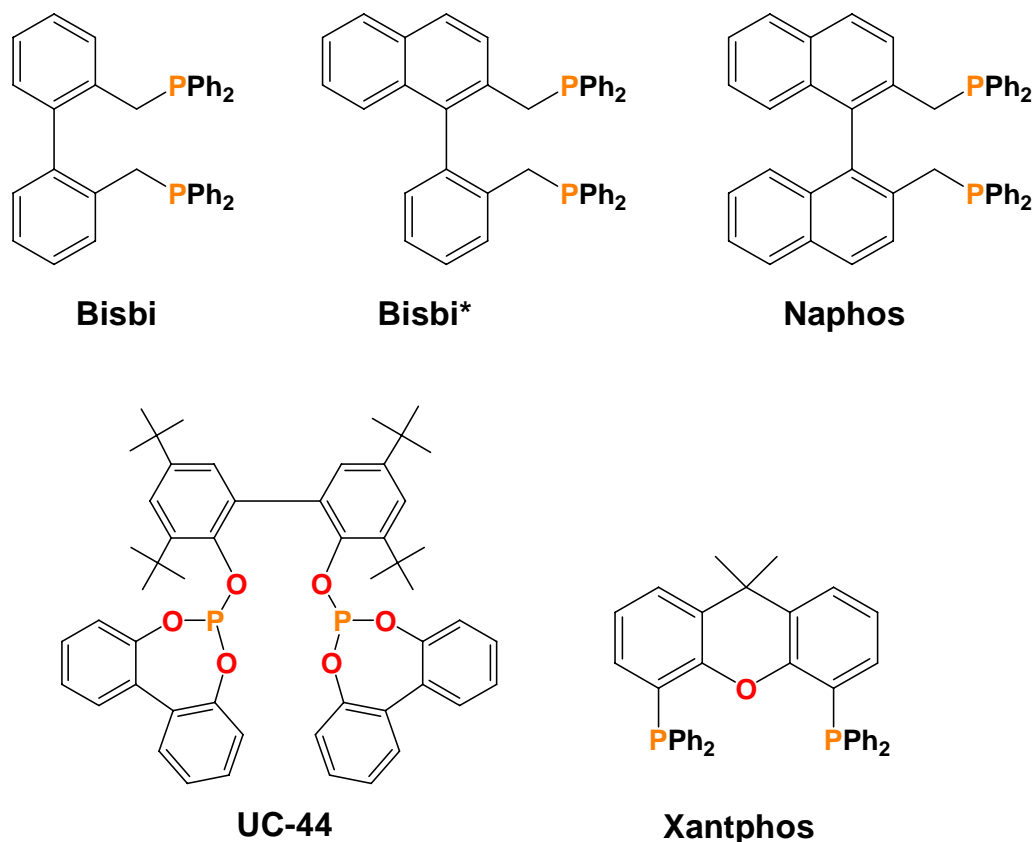

A closely related bisphosphine ligand used by Herrmann and Beller (independently) for hydroformylation studies is Naphos (not to be confused with the Binap bisphosphine ligand that has the PPh₂ groups directly bonded to the naphthalene rings).

Prof. Piet van Leeuwen at the University of Amsterdam developed the Xantphos family of ligands that also show high L:B regioselectivities and activities similar to that of Rh/PPh₃. Some catalytic comparisons between Rh/PPh₃, Bisbi, Naphos and Xantphos for the hydroformylation of 1-hexene are shown below (90°C, 6.2 bar 1:1 H₂/CO, 1000 eq. 1-hexene, acetone solvent, iso = isomerization):

Catalyst (1 mM)	Init TOF (min ⁻¹)	Aldehyde L:B	% iso
Rh/PPh ₃ (1:400)	13(1)	9:1	< 0.5
Rh/Bisbi (1:5)	25(2)	70:1	< 0.5
Rh/Naphos (1:5)	27(1)	120:1	1.5
Rh/Xantphos (1:5)	13(2)	80:1	5.0

The Union Carbide (now Dow) ligand system, UC-44, developed by Billig and co-workers is a bulky bisphosphite ligand that also forms a 9-membered chelate ring to the rhodium center. This generates a highly regioselective hydroformylation catalyst that, like BISBI/Naphos, has linear to branched aldehyde product ratios for the hydroformylation of propylene of well over 30:1. Due to the presence of the poorly σ -donating **phosphite** ligands, however, the rhodium center is highly active, giving hydroformylation rates for 1-alkenes that are about 5 times faster than Rh/PPh₃ catalysts. Indeed, the catalyst is active enough and a good enough isomerization catalyst to give high linear regioselectivities for the hydroformylation of some internal alkenes, particularly, 2-butene (25:1 linear to branched aldehyde ratio). This could form the basis of a new fourth generation hydroformylation technology.

Rh-induced ligand fragmentation problems, however, may well limit the commercialization of these active and selective catalyst systems. Phosphite ligands, in particular, are sensitive to Rh-induced and organic cleavage reactions.

Casey and van Leeuwen have proposed and presented good evidence that *part* of the regioselectivity in rhodium bisphosphine catalysts is related to the ability of the chelating phosphine to favor an equatorially chelated trigonal bipyramidal structure, i.e., maintain a metal chelate bite angle around 120°. This is referred to as the “Bite Angle Hypothesis.” All the new generation bulky chelating ligands are indeed capable of doing this, while “normal” chelating ligands, such as bis(diphenylphosphino)ethane (dppe), cannot and give very poor selectivities.

Bimetallic Hydroformylation

A unique bimetallic rhodium complex that provides a very strong example of bimetallic cooperativity in homogeneous catalysis has been reported by Stanley and coworkers.²¹ They designed a novel binucleating tetraphosphine ligand (*racemic*- and *meso*-*et,ph-P4*) that can both bridge and chelate two transition metal centers, producing bimetallic complexes that only have a single, conformationally flexible bridging group.

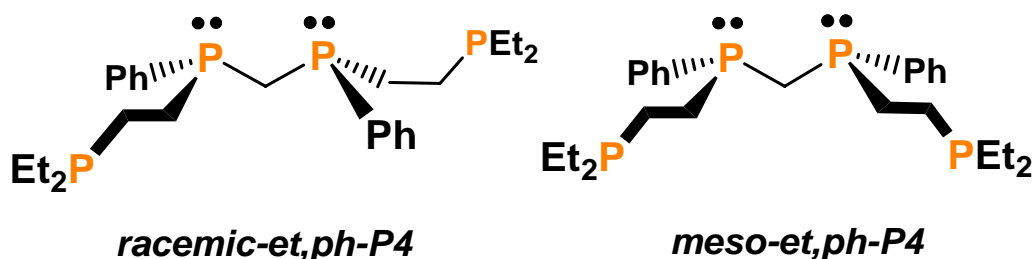

$[Rac-Rh_2(nbd)_2(et,ph-P4)](BF_4)_2$ (nbd = norbornadiene) is a catalyst precursor to a highly active and regioselective hydroformylation catalyst for 1-alkenes under mild conditions (the *meso*- Rh_2 complex is far less active and has much higher side reactions). A comparison between $[rac-Rh_2(nbd)_2(et,ph-P4)](BF_4)_2$ and some of the best monometallic catalysts is shown in the table below (90°C, 6.2 bar 1:1 H_2/CO , 1000 eq. 1-hexene, acetone solvent). It was also discovered that adding 30% water to the acetone solvent dramatically reduces catalyst degradation rxns, increasing both the rate and selectivity.²²

Catalyst (1 mM)	Init TOF (min^{-1})	Aldehyde L:B	% iso
$[rac-Rh_2P_4]^{2+}$	20(1)	25:1	2.5
$[rac-Rh_2P_4]^{2+}$ (30% H_2O)	73(1)	33:1	< 0.5
Rh/ PPH_3 (1:400)	13(1)	9:1	< 0.5
Rh/ <i>Bisbi</i> (1:5)	25(2)	70:1	< 0.5
Rh/ <i>Naphos</i> (1:5)	27(1)	120:1	1.5
Rh/ <i>Xantphos</i> (1:5)	13(2)	80:1	5.0

Since the *racemic*- $\text{Rh}_2(\text{nbd})_2(\text{et,ph-P4})^{2+}$ precursor complex does not have a Rh-Rh bond it was straight forward to prepare mono- and bimetallic model systems to test whether the two metal centers were working independently or if the complex was fragmenting to generate active monometallic species. The hydroformylation activity of a series of monometallic complexes and spaced bimetallic complexes (shown below) were studied. These were all found to be *terrible* hydroformylation catalysts, giving extremely poor rates and selectivities.

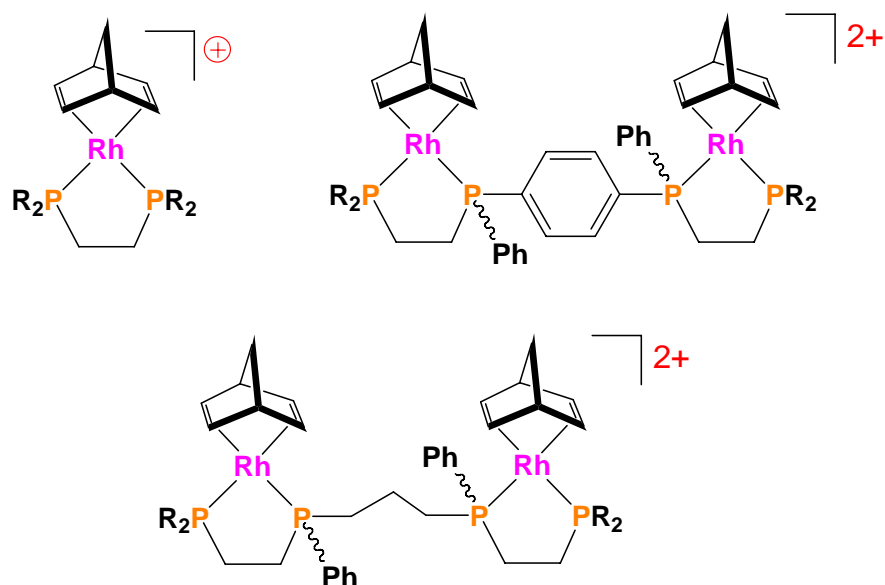

This led to the initial proposal of a bimetallic cooperativity mechanism involving *neutral* bimetallic complexes. When one started with a neutral bimetallic complex like *rac*- $\text{Rh}_2(\eta^3\text{-allyl})_2(\text{et,ph-P4})$ a very poor hydroformylation catalyst formed. Subsequent *in situ* FT-IR spectroscopic studies on *racemic*- $\text{Rh}_2(\text{nbd})_2(\text{et,ph-P4})^{2+}$ and *racemic*- $\text{Rh}_2(\eta^3\text{-allyl})_2(\text{et,ph-P4})$ under H_2/CO pressure and catalytic conditions clearly revealed that the active bimetallic catalyst complex has high frequency terminal CO stretching frequencies, leading to the conclusion that it is a dicationic hydrido-carbonyl complex.²³ Furthermore, the catalyst activity appears to track with the intensity of the bridging CO bands around 1835 cm^{-1} , leading to the following proposed active catalyst structure.

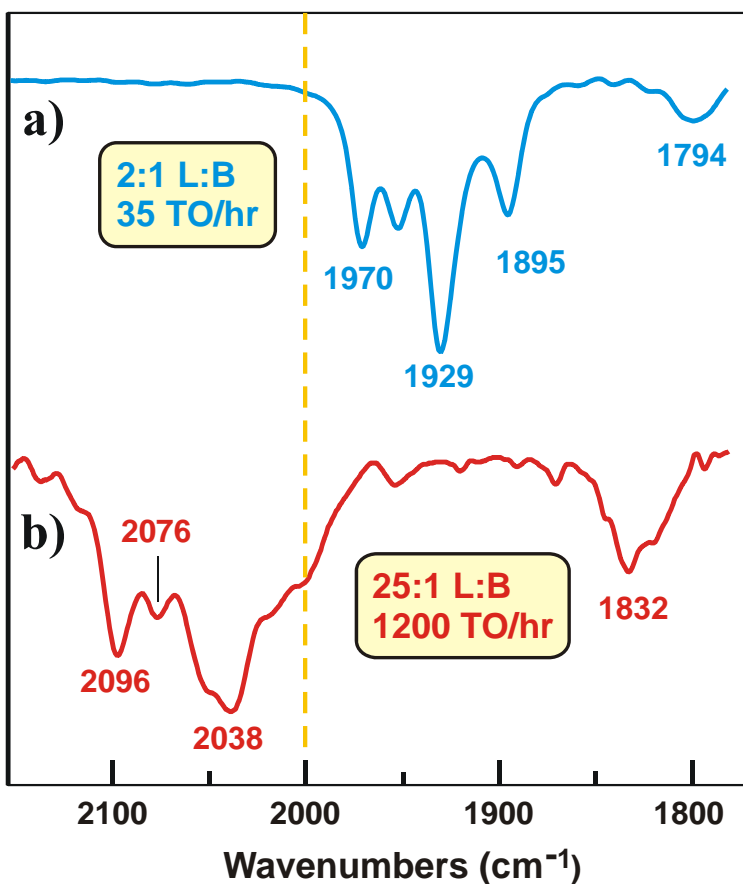

Catalyst Precursor

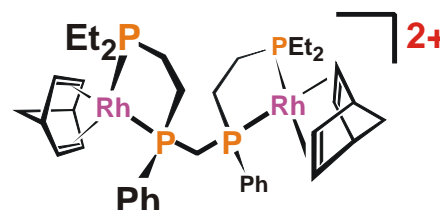
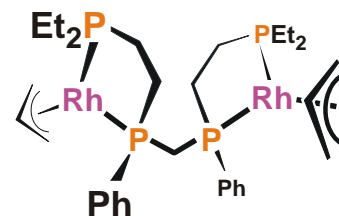

90 psig H_2/CO , 90°C

Proposed active dirhodium catalyst:

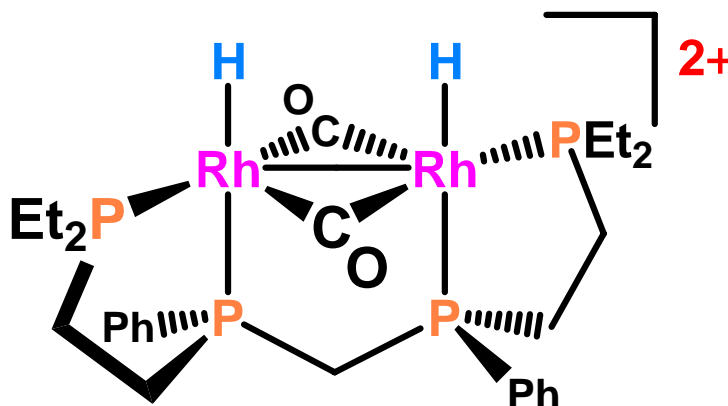

There is a facile terminal CO addition-dissociation equilibrium on the species above (each Rh is $16e^-$) to generate complexes with one or two additional terminal CO ligands.

Problem: Why is the dicationic charge so important on this catalyst?

The proposed mechanism for this dicationic bimetallic catalyst is shown below:

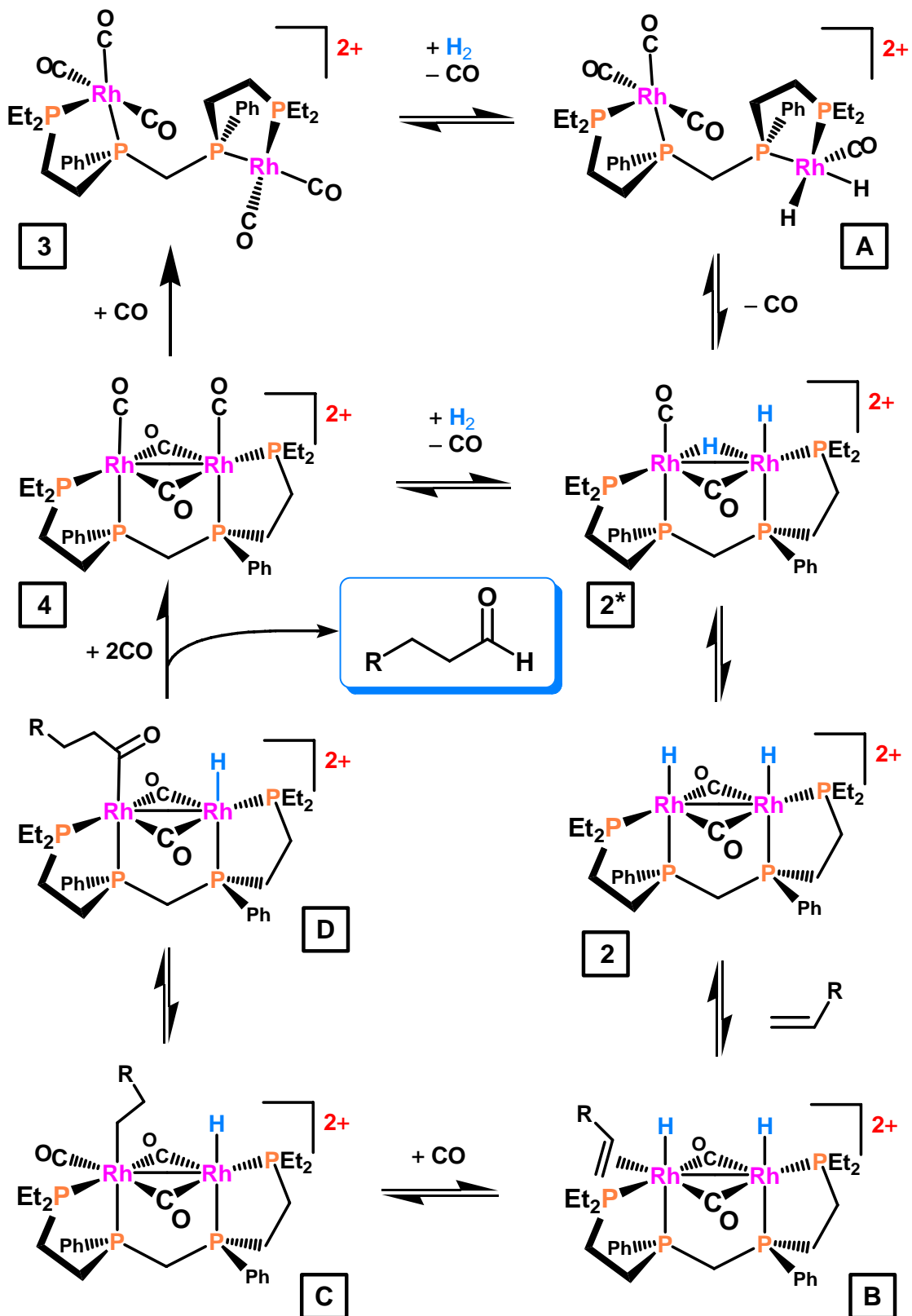

- 1) D. S. Breslow and R. F. Heck, *Chem. Ind. (London)*, 1960, 467.
- 2) R. F. Heck and D. S. Breslow, *J. Am. Chem. Soc.*, 1961, **83**, 4023.
- 3) R. Wyman, *J. Organomet. Chem.*, 1974, **66**, C23.
- 4) M. F. Mirbach, *J. Organomet. Chem.*, 1984, **265**, 205.
- 5) W. R. Moser, in 'ACS Advances in Chemistry Series', eds. W. R. Moser and D. W. Slocum, ACS, Washington, D.C., 1992, Vol. 230, Chapter 1, p. 14.
- 6) B. Fell, W. Rupilius, and F. Asinger, *Tetrahedron Lett.*, 1968, 3261.
- 7) M. Bianchi, F. Paicenti, P. Frediani, and U. Matteoli, *J. Organomet. Chem.*, 1977, **137**, 361.
- 8) B. L. Haymore, A. van Asselt, and G. R. Beck, *Ann. New York Acad. Sci.*, 1984, **415**, 159.
- 9) L. H. Slaugh and R. D. Mullineaux, *J. Organometal. Chem.*, 1968, **13**, 469.
- 10) R. L. Pruett and J. A. Smith, *J. Org. Chem.*, 1969, **34**, 327.
- 11) R. V. Kastrup, J. S. Merola, A. A. Oswald, in 'ACS Advances in Chemistry Series', eds. E. L. Alyea and D. W. Meek, ACS, Washington, D.C., 1982, Vol. 196, Chapter 3, p. 43.
- 12) W. R. Moser, C. J. Papile, D. A. Brannon, R. A. Duwell, and S. J. Weininger, *J. Mol. Catal.*, 1987, **41**, 271.
- 13) C. A. Tolman and J. W. Faller, in 'Homogeneous Catalysis with Metal Phosphine Complexes', ed. L. H. Pignolet, Plenum, New York, 1983, Chapter 2, p. 93.
- 14) A. G. Abatjoglou, E. Billig, and D. R. Bryant, *Organometallics*, 1984, **3**, 923.
- 15) M. Lewin, Z. Aizenshtat, and J. Blum, *J. Organomet. Chem.*, 1980, **184**, 255.
- 16) W. R. Moser, C. J. Papile, and S. J. Weininger, *J. Mol. Catal.*, 1987, **41**, 293.
- 17) C. Bianchini, A. Meli, M. Peruzzini, and F. Vizza, *Organometallics*, 1990, **9**, 226.
- 18) G. Kiss and I. Horváth, *Organometallics*, 1991, **10**, 3798.
- 19) M. Matsumoto and M. Tamura, *J. Mol. Catal.*, 1982, **16**, 209.
- 20) M. Matsumoto and M. Tamura, *J. Mol. Catal.*, 1982, **16**, 195.
- 21) M. E. Broussard, B. Juma, S. G. Train, W.-J. Peng, S. A. Laneman and G. G. Stanley, *Science*, **1993**, **260**, 1784.
- 22) D. A. Aubry, N. N. Bridges, K. Ezell, and G. G. Stanley, *J. Am. Chem. Soc.*, **2003**, *125*, 11180.
- 23) R. C. Matthews, D. K. Howell, W.-J. Peng, S. G. Train, D. W. Treleaven, G. G. Stanley, *Angew. Chem. Int. Ed.*, 1996, *35*, 2253.

Monsanto (BP) Acetic Acid & Related Processes

The carbonylation of methanol produces acetic acid:

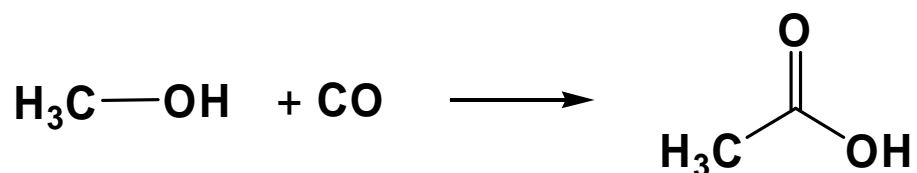

This is the second largest industrial homogeneous carbonylation process with over 7 billion pounds of acetic acid produced each year using this technology. Prior to 1970, acetic acid was made using cobalt catalysts (BASF process) requiring rather severe conditions. In 1970 Monsanto commercialized a rhodium carbonyl iodide catalyst that is commonly called the **Monsanto Acetic Acid Process** (developed in the late 60's by James Roth and his research team at the corporate research center in St. Louis). In 1986 Monsanto sold the acetic acid plant and technology to British Petroleum (BP), but it is still commonly referred to as the Monsanto Acetic Acid process.

As with hydroformylation catalysis, rhodium is 10^3 to 10^4 times more active than the corresponding cobalt catalyst, which means that much lower CO pressures and moderately lower temperatures are required. Most importantly, the rhodium catalyst gives extremely high selectivities to acetic acid:

	Cobalt	Rhodium
Concentration	$\sim 10^{-1}$ M	$\sim 10^{-3}$ M
Temperature	$\sim 230^\circ$ C	$\sim 180^\circ$ C
Pressure	500-700 atm	30-40 atm
Selectivity	90%	> 99%
H ₂ effect	CH ₄ , CH ₃ CHO, EtOH byproducts	no adverse effect

The mechanism has been extensively studied by Forster and coworkers at Monsanto and is shown below. This catalytic reaction is an unusual dual cycle system involving HI as one catalyst and $[\text{RhI}_2(\text{CO})_2]^-$ as the transition metal component. HI catalyzes the conversion of MeOH to MeI and H_2O at the beginning of the Rh-catalyzed carbonylation reaction, followed by regeneration of HI at the end of the Rh-cycle by hydrolysis of the acyl-iodide. The Rh catalyst carbonylates the MeI to produce the acyl-iodide.

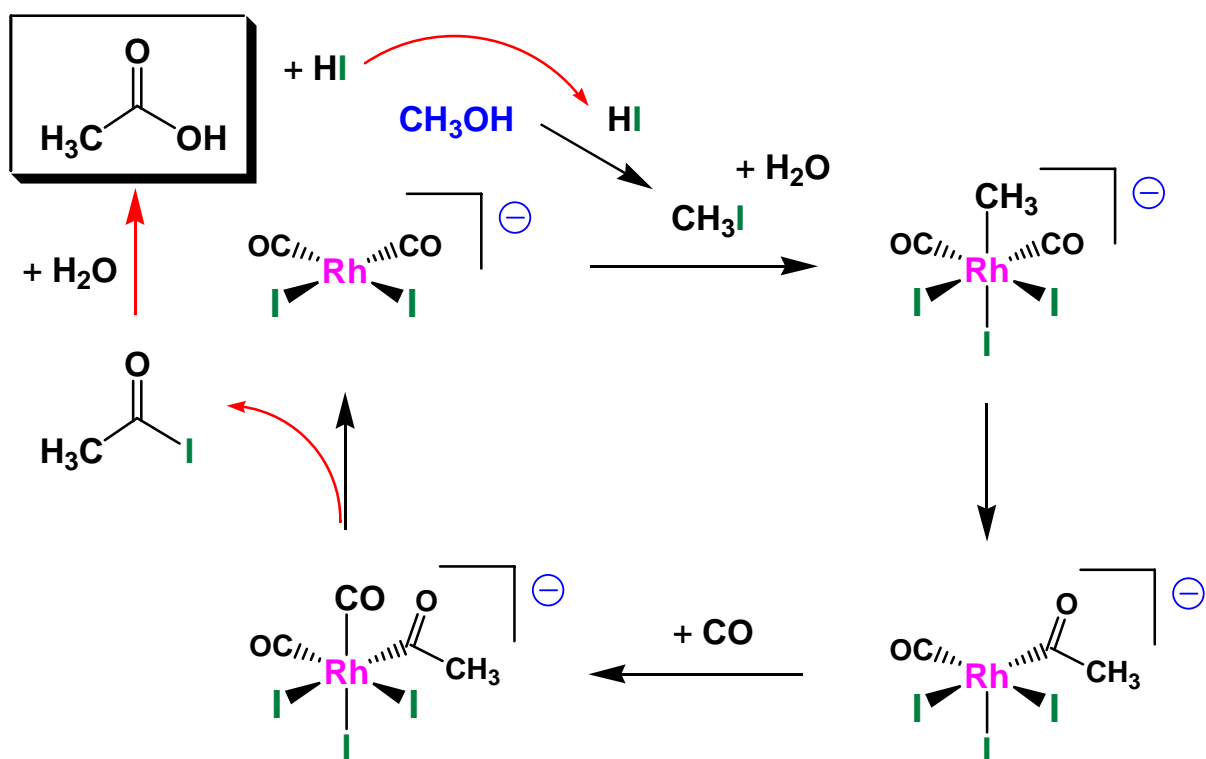

The reaction is independent of CO pressure, and first order in both rhodium and MeI. The rate determining step is the oxidative addition of MeI to the $[\text{Rh}(\text{CO})_2\text{I}_2]^-$ catalyst. Thus, the production of MeI from methanol, catalyzed by HI, is critically important. Iodide ligands are considered to be quite important in this reaction due to the HI catalyzed conversion of MeOH to MeI and their relatively good donor abilities on the Rh center. The negative charge on the $[\text{Rh}(\text{CO})_2\text{I}_2]^-$ catalyst is believed to be critical in assisting the oxidative addition of MeI to the rhodium center. The alkyl species, $[\text{Rh}(\text{CO})_2(\text{Me})\text{I}_3]^-$, is extremely reactive towards CO insertion to form the acyl complex.

Celanese LiI Modified “Low Water” Catalyst System

One problem with the original Monsanto process is that moderately high amounts of H_2O are needed to produce H_2 in the reactor via the **water-gas shift rxn** ($\text{CO} + \text{H}_2\text{O} \rightleftharpoons \text{CO}_2 + \text{H}_2$). The water and H_2 were needed to react with precipitated RhI_3 and “inactive” $[\text{RhI}_4(\text{CO})_2]^-$, which formed from side reactions, to regenerate the active Rh(I) catalyst. The reaction of water with inactive $[\text{RhI}_4(\text{CO})_2]^-$ to generate active Rh(I) catalyst, $[\text{RhI}_2(\text{CO})_2]^-$, is shown below.

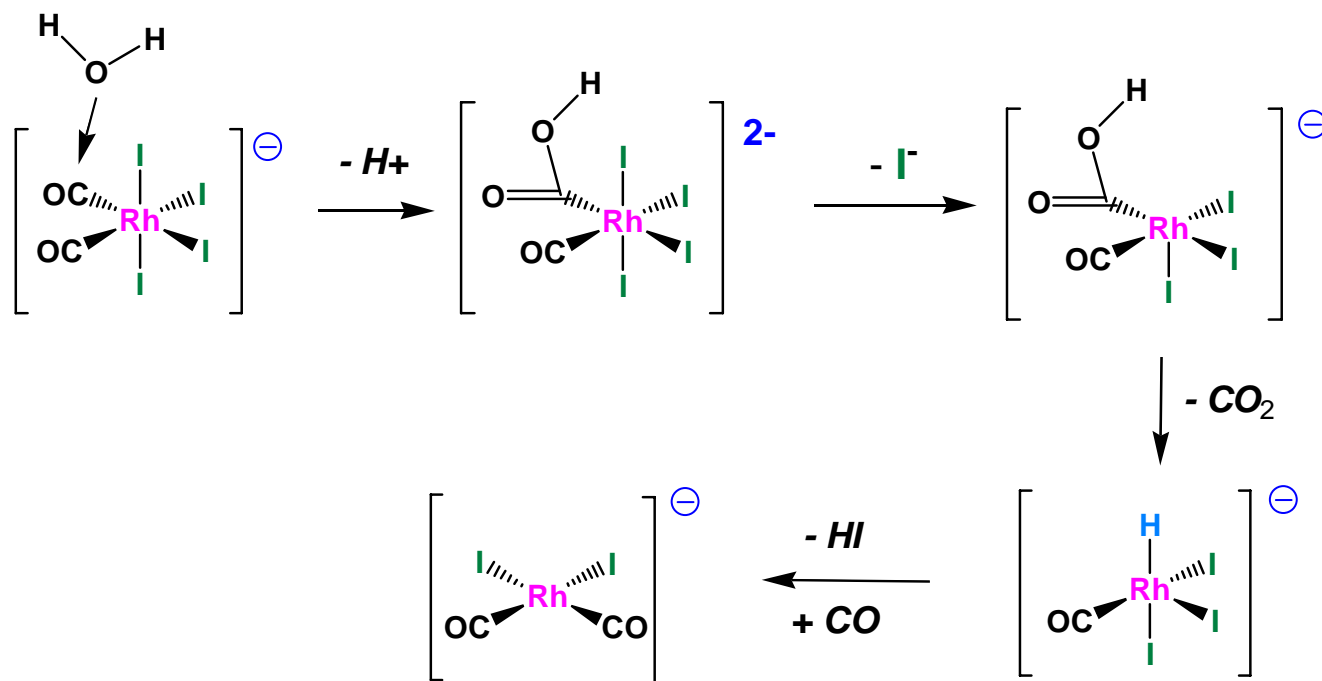

The relatively high amounts of H_2O needed also increases the amount of the highly corrosive HI present leading to engineering problems. The water reactivation process is also not especially efficient leading to more inactive Rh present in the reactor.

In the late 70's Celanese developed a major improvement on the Monsanto technology not covered by their narrow patent that involved the simple addition of LiI (and other proprietary modifiers) to reduce the amount of H_2O (and HI) used in the catalysis. Added LiI increased the catalyst stability by minimizing the side reactions that produced inactive Rh(III) species. It also increased the amount of the more reactive dianionic $[\text{RhI}_3(\text{CO})_2]^{2-}$ catalyst species. This considerably increased the catalyst activity, throughput, and efficiency.

Problem: Increasing the iodide concentration increases the amount of the following 18e- complex. Why is this more reactive and why doesn't this saturated 18e- complex slow down the subsequent oxidative addition reaction with MeI?

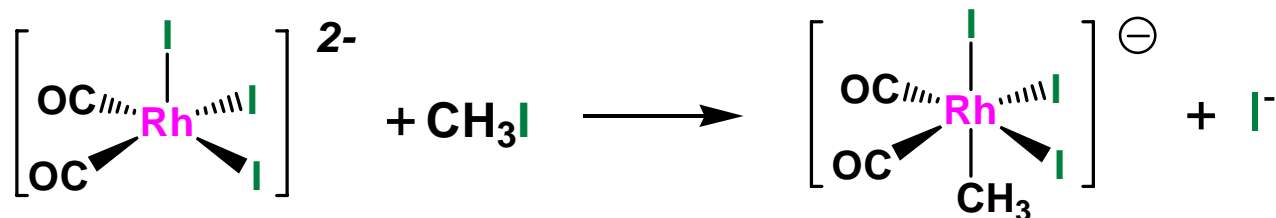

BP Ir-Based Cativa System

The Cativa Ir-based acetic acid catalyst system was announced with much fanfare in 1999. However, much of this catalytic chemistry was part of the original Monsanto Acetic Acid patent. The Ir cycle was originally studied in considerable detail by Forster (along with the Rh system) in 1979 (*JCS Dalton*, 1979, 1639). The fundamental mechanism is essentially the same as the Rh cycle:

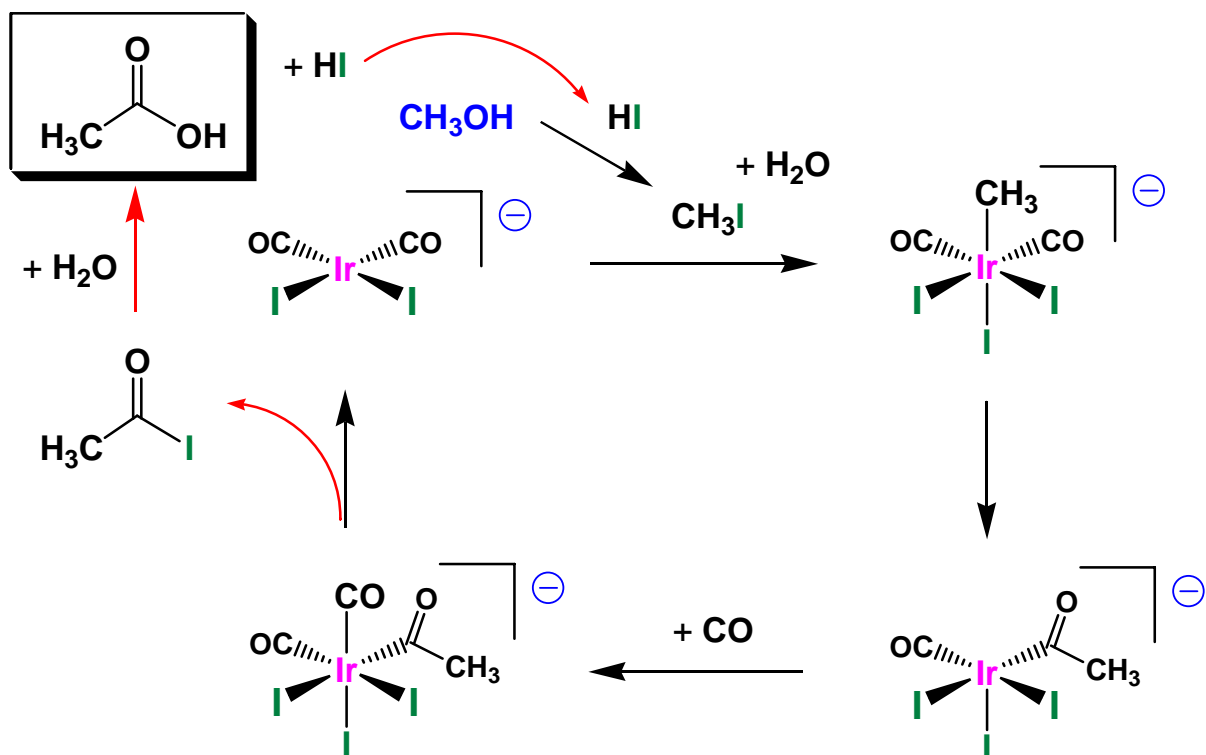

The main differences between the Ir and Rh catalyst systems:

- 1) The rate determining step for Ir is the migratory insertion of the Ir-CH₃ and Ir-CO ligands. The MeI oxidative addition step is faster for Ir due to its lower electronegativity.
- 2) The stronger Ir-ligand bonds slow down the migratory insertion step and reductive elimination steps (Foster noted this in 1979 paper).
- 3) There are considerably fewer side reactions in the Ir system to make inactive M(III) complexes (soluble or insoluble). This is also tied into point #2.

This enables the use of low water conditions that makes the BP Ir system competitive with the Celanese LiI modified low water high-activity Rh catalyst. Due to patents issued by Celanese and Eastman (see next section), BP could not make use of “normal” additives to convert the Rh catalyst to a low water system.

BP found, however, that a modifier was needed to remove an iodide ligand to generate less electron-rich (more unsaturated) complexes that would favor the CO-methyl migratory insertion and the final reductive elimination of acyl-iodide. They found that added RuI₂(CO)₃ would reversibly abstract an iodide ligand from the [IrI₃(CH₃)(CO)₂]⁻ complex to enhance the rate of the CO-methyl migratory insertion. The enhancing effect is shown in the graph to the right.

(Haynes, *JACS*, 2004, 126, 2847)

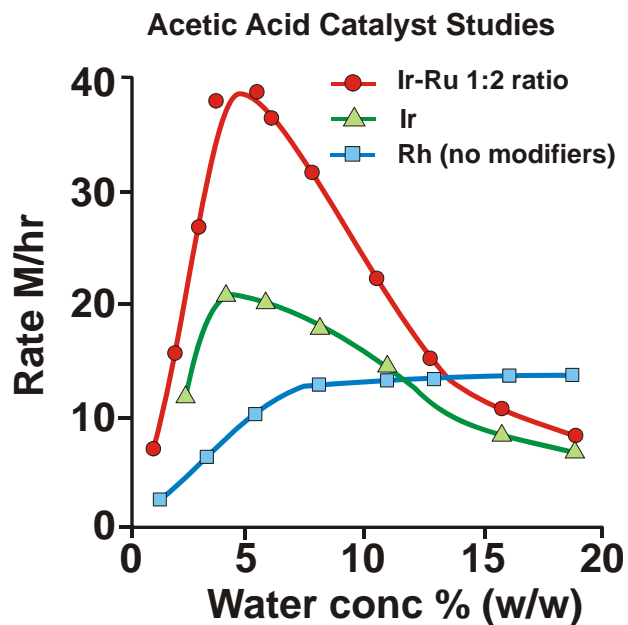

Eastman Chemical Acetic Anhydride Process

A very closely related process is the Eastman Chemical carbonylation of **methyl acetate** to produce acetic anhydride. This was commercialized in 1983 and produces over 800 million pounds of acetic anhydride a year at their Kingston, TN plant.

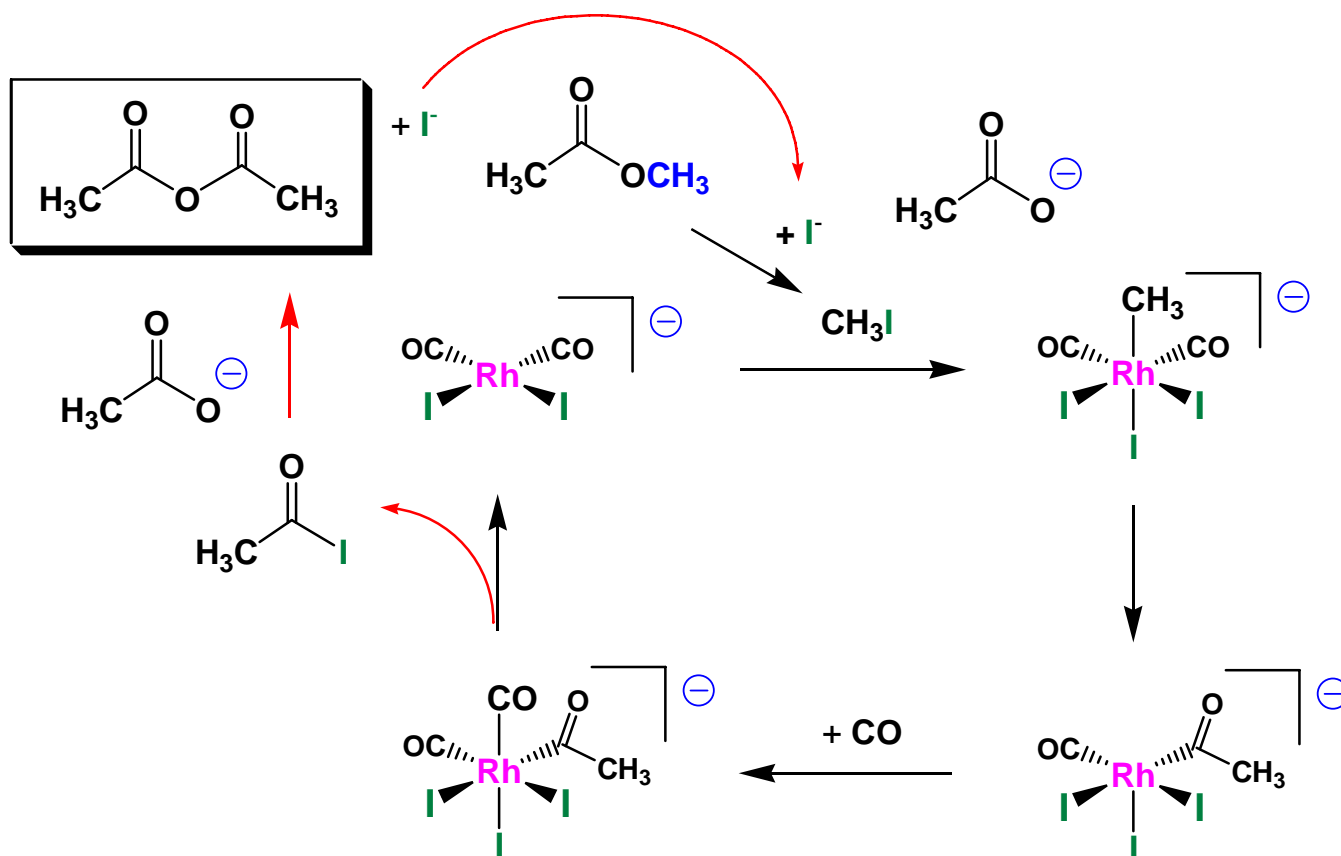

Note that this is essentially the same as the Monsanto/Celanese processes, only the initial reactant has changed. Eastman also worked out that adding excess Li(acetate), much like Celanese adds LiI, eliminates the need for water completely, which is important if one wants to make water sensitive acetic anhydride.

Since this wasn't covered by the Monsanto (or Celanese) patents, Eastman Chemical didn't have to pay any royalty or licensing fee, saving them a bunch of \$\$.

Coupling Reactions

Organometallic chemistry has provided important new methods to carry out carbon-carbon or carbon-heteroatom bond formation. Such processes, termed **coupling reactions**, now have a central place in organic synthesis. The most important ones are summarized below. They often bear the name of their discoverer (organic tradition).

Stille coupling:

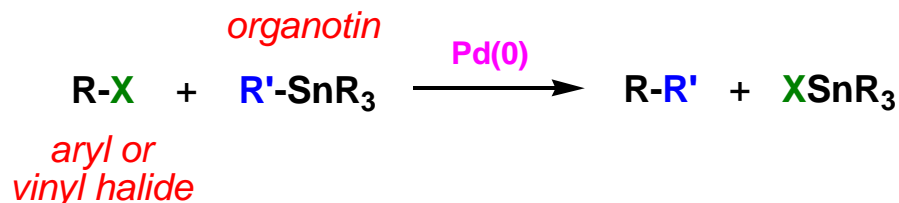

Negishi coupling:

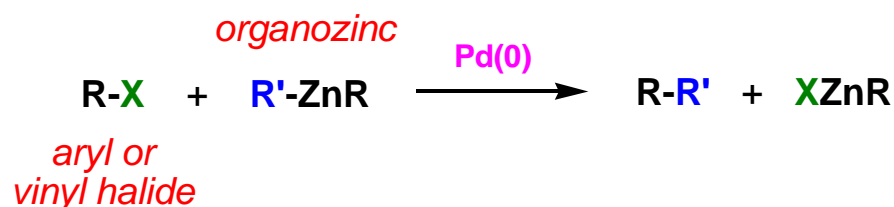

Suzuki coupling:

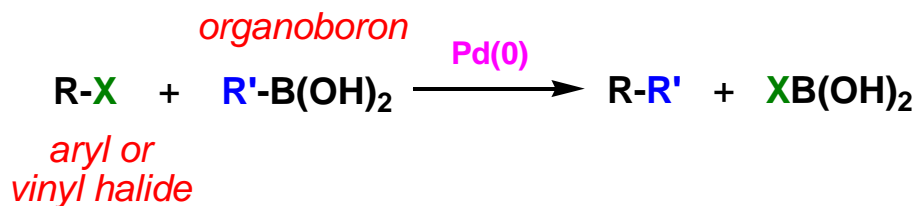

Heck reaction:

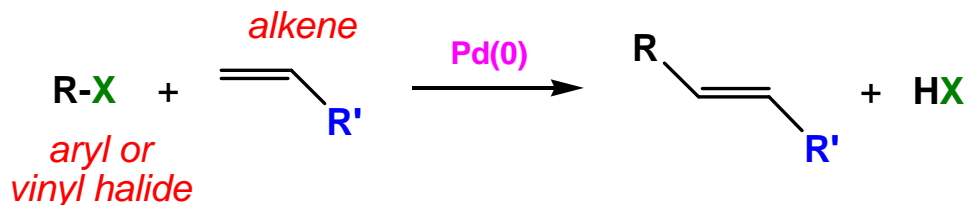

Sonogashira coupling:

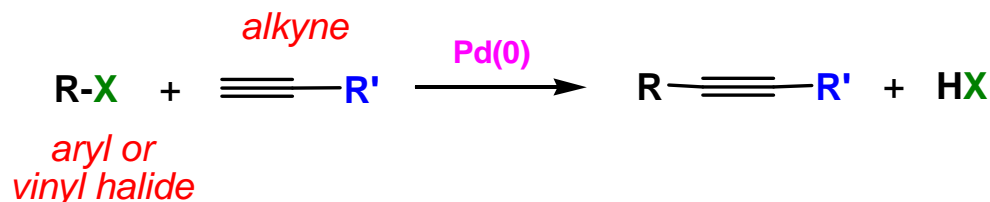

Cross-Coupling of Organometallics and Halides

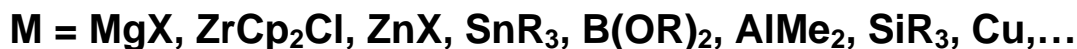
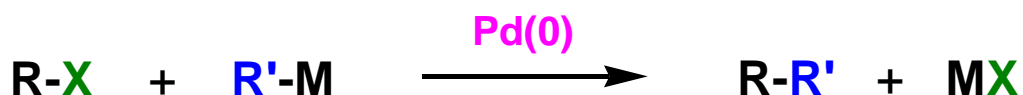

The mechanism involves oxidative addition of the halide or triflate to the initial Pd(0) phosphine complex to form a Pd(II) species. The key slow step is a **transmetallation**, so called because the nucleophile (**R'**) is transferred from the metal in the organometallic reagent to the palladium and the counterion (**X** = halide or triflate) moves in the opposite direction. The new Pd(II) complex with two organic ligands undergoes reductive elimination to give the coupled product and the Pd(0) catalyst ready for another cycle.

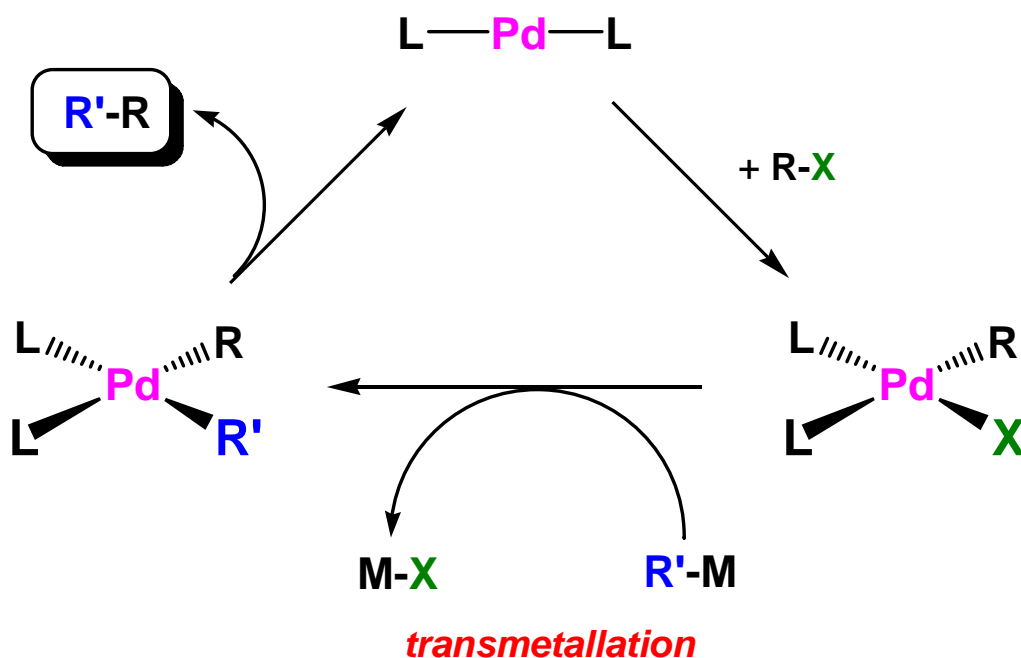

The halide partner (**R-X**) must be chosen with care, as β -hydride elimination would decompose the first intermediate during the slow transmetallation step. The choice for **R** is restricted to substituents without β -hydrogen atoms: vinyl, allyl, benzyl, and polyfluoroalkyl halides, triflates, and phosphates have all been coupled successfully.

The organometallic reagent (**R'-M**) can be based on Mg, Zn, Cu, Sn, Si, Zr, Al, or B and the organic fragment can have a wide variety of structures as coupling is faster than β -hydride elimination.

Formation of the active species may conveniently be carried out *in situ* by reduction of a Pd(II) precursor, for example, PdCl₂, Pd(OAc)₂, or Na₂PdCl₄. The reduction of Pd(II) to Pd(0) can be achieved with amines, phosphines, alkenes, and organometallics such as DIBAL-H, butyl lithium, or trialkylaluminium.

Reduction with Et₃N:

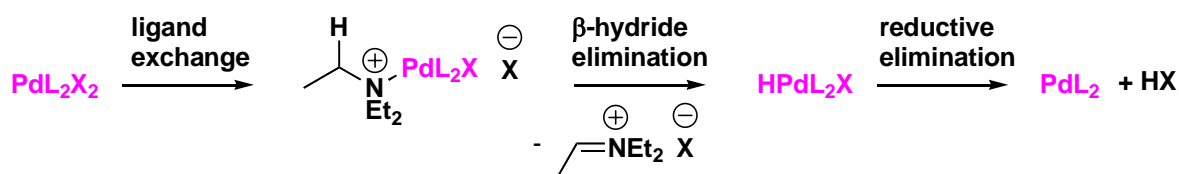

Reduction with PPh₃:

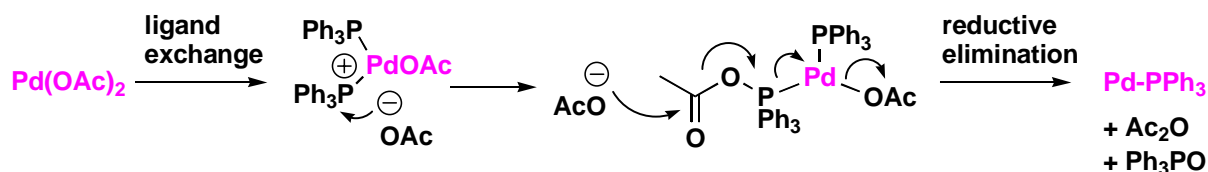

Reduction with ethylene:

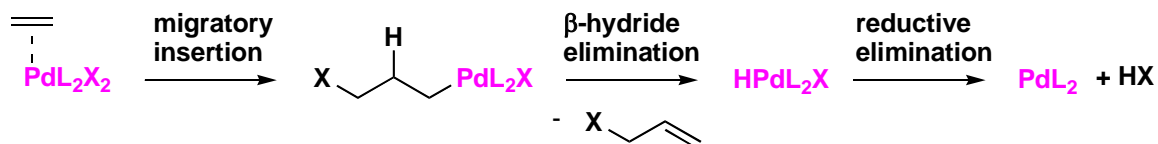

Reduction with an organometallic:



Usually, a stoichiometric excess of an amine such as Et₃N is part of the reaction mixture, serving both as a base to trap the **HX** formed and as a reducing agent for Pd.

Stille Coupling

The Stille coupling uses organotin compounds (called stannanes) as organometallic components. Since its first reported use in the late 1970's, the reaction has been widely used for the coupling of both aromatic and vinylic systems. The Stille coupling represents over half of all current cross-coupling reactions, however, due to their high toxicity, stannanes tend to be replaced more and more with organozinc and organoboron compounds.

The reaction may be carried out intramolecularly and with alkynyl stannanes instead of the more usual aryl or vinyl stannanes to form medium-sized rings. For example, the reaction below forms a 10-membered ring containing two alkynes.

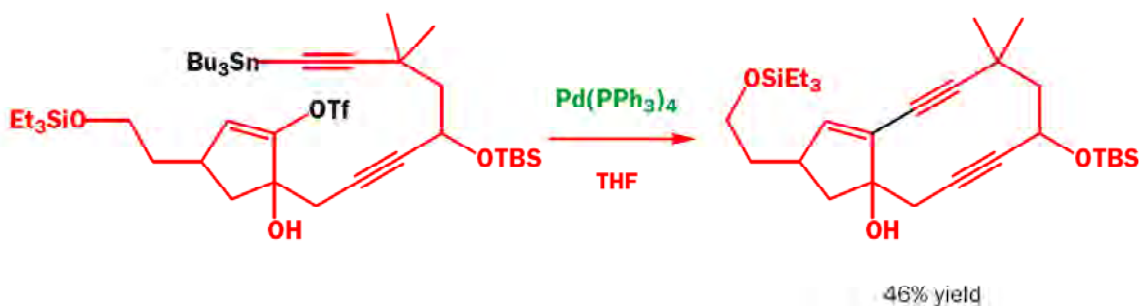

Suzuki Coupling

Since first being published in 1979, the Suzuki coupling of a boronic acid with a halide or triflate has developed into one of the most important cross-coupling reactions, totalling about a quarter of all current palladium-catalysed cross-coupling reactions.

As in the Stille coupling, the geometry of unsaturated components is preserved during the coupling, so this is an excellent method for stereospecific diene synthesis. For example, coupling of an *E*-vinyl boronic acid with a *Z*-vinyl bromide in toluene in the presence of $\text{Pd}(0)$ with potassium hydroxide as the base gave the corresponding *E,Z*-diene in good yield.

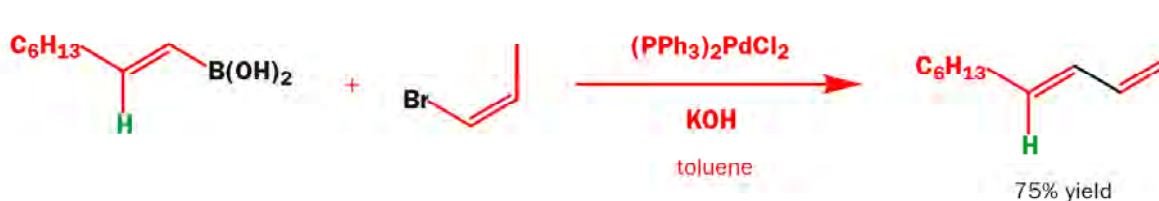

The mechanism of the Suzuki reaction proceeds by oxidative addition of the vinylic or aromatic halide to the Pd(0) complex and generates a Pd(II) intermediate. This intermediate undergoes a transmetalation with the alkenyl boronate, from which the product is expelled by reductive elimination, regenerating the Pd(0) catalyst. One difference between the Suzuki and Stille couplings is that the boronic acid must be activated, usually with a base such as sodium or potassium ethoxide or hydroxide. The base converts the borane (BR_3) into more a reactive boronate ($\text{BR}_3(\text{OH})^-$). Activation of the boron atom enhances the polarization of the organic ligand and facilitates the transmetalation step.

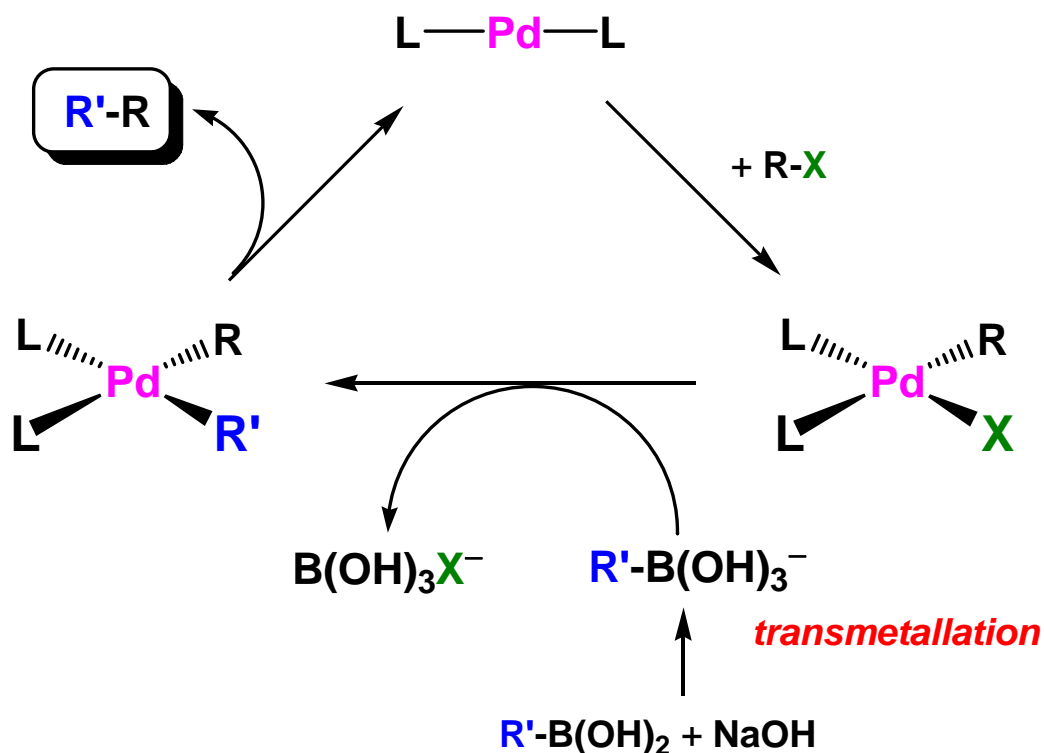

Heck Reaction

The Heck reaction is a powerful and efficient method for C–C bond formation in which haloarenes and haloalkenes (or triflates) couple with alkenes in the presence of a Pd(0) catalyst to form a new alkene. The process is often stereo- and regioselective.

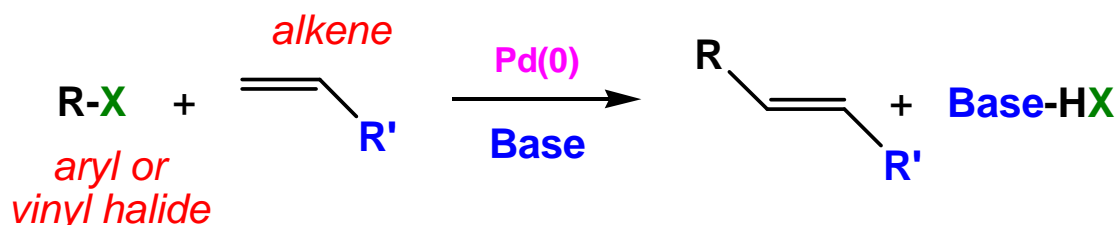

- **R** can be an aryl, vinyl, benzyl or allyl group (in other words, any group without β-hydrogens on a sp³ carbon atom).
- **X** can be a halide (Cl, Br, or I) or triflate (OSO₂CF₃).
- The **alkene** can be mono- or disubstituted and can be electron-rich, -poor, or neutral.
- The **base** does not have to be strong. Et₃N, NaOAc, or aqueous Na₂CO₃ are often used. The **base** is, however, stoichiometric and one equivalent of base is generated for each equivalent of product.
- The catalyst is a **Pd(0)** complex either preformed or generated *in situ* from stable Pd(II) precursors.

The rate of reaction and regioselectivity are sensitive to steric hindrance about the C=C bond of the vinylic partner. For simple aryl halides reacting with alkenes, the rate of reaction as a function of alkene substitution varies according to the following sequence:

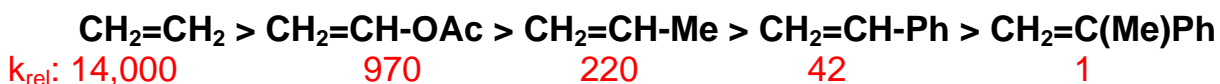

The regioselectivity of addition is given below for a number of alkenes. Although electronic effects may play a small role in directing attack by the metal in the insertion step, steric effects seem to be the dominant factor by far.

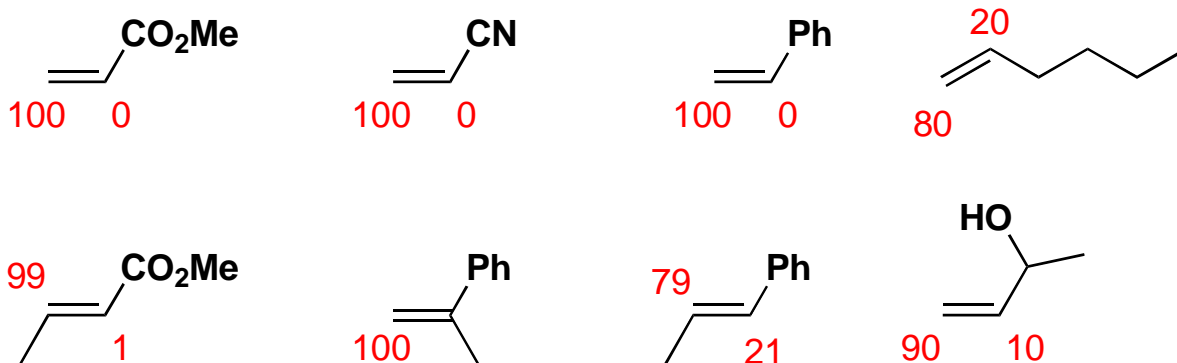

The mechanism involves the oxidative addition of the halide, insertion of the olefin, and release of the product through a β -hydride elimination. A base then regenerates the Pd(0) catalyst via reductive elimination and closes the catalytic cycle. Two alternate mechanisms (one cationic) are shown below with the same general sequence of steps.

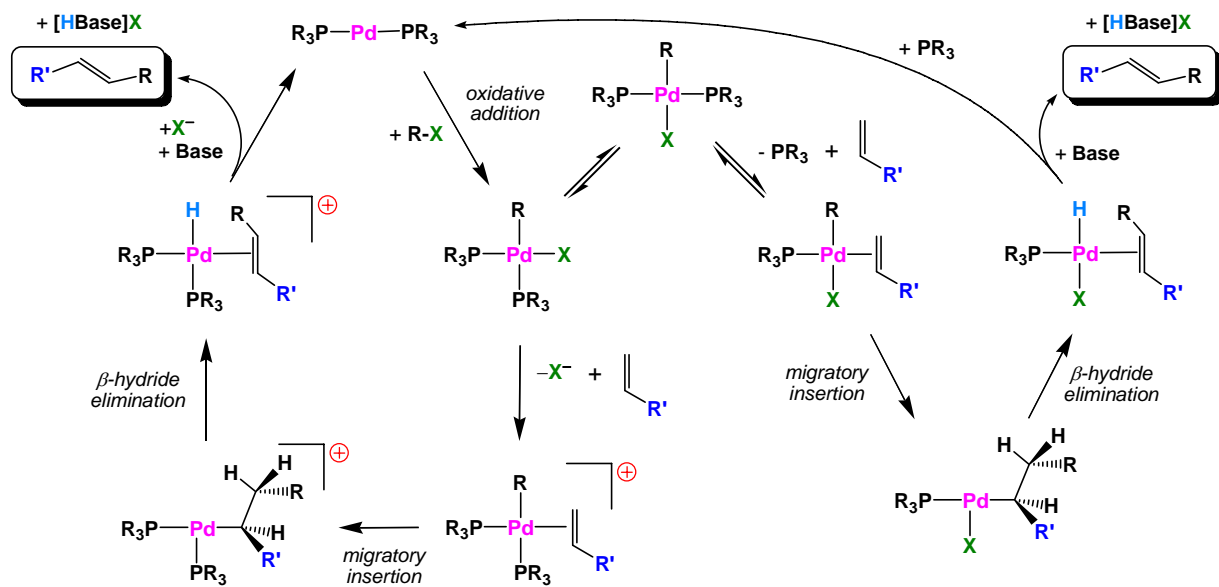

The Heck reaction differs significantly from the earlier Pd(0)-catalyzed cross-coupling reactions because:

- 1) it involves an insertion after the oxidative addition step
- 2) the catalytic cycle is closed with a β -hydride elimination, whereas the other couplings end with a reductive elimination.

In the β -hydride elimination step, the palladium and hydride must be coplanar for the reaction to take place, as this is a *syn* elimination process. For steric reasons, the **R** group will tend to eclipse the smallest group on the adjacent carbon as elimination occurs, leading predominantly to a *trans* double bond in the product.

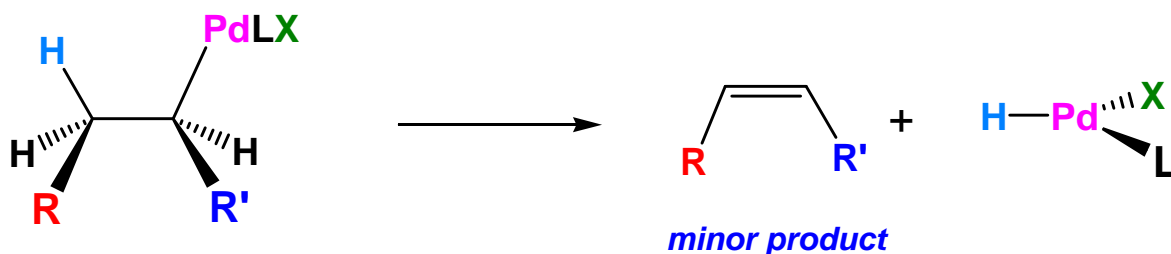
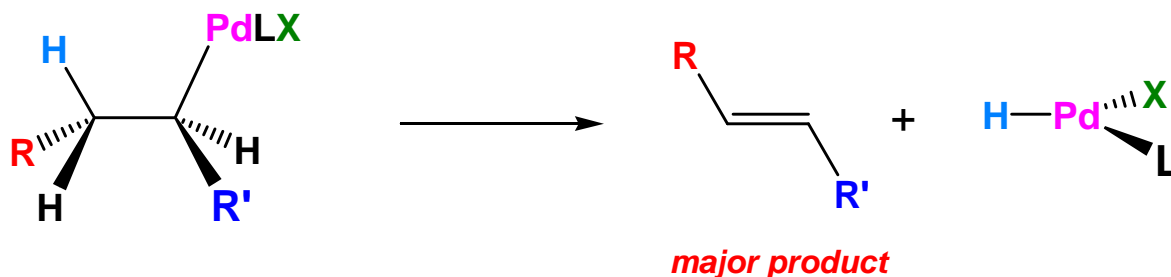

Applications of the Heck reaction in organic synthesis

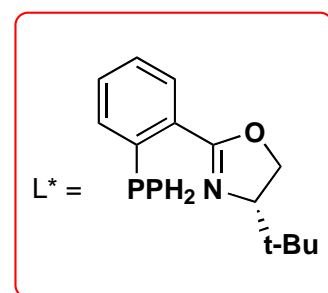
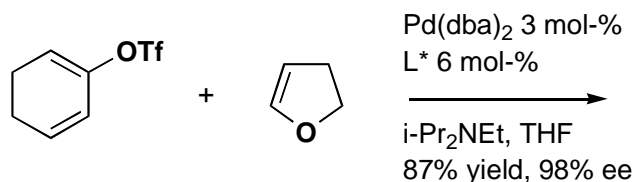
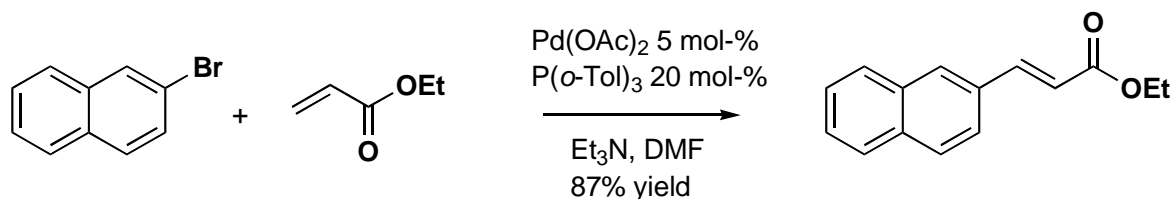
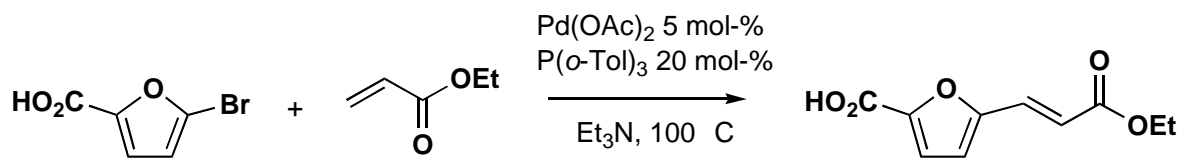

Sonogashira Coupling

The coupling of terminal alkynes with aryl or vinyl halides under palladium catalysis is known as the Sonogashira reaction. This catalytic process requires the use of a palladium(0) complex, is performed in the presence of base, and generally uses copper iodide as a co-catalyst.

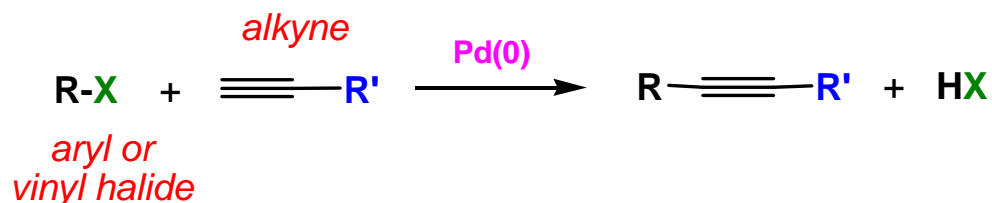

The mild conditions usually employed (frequently room temperature) mean that the Sonogashira coupling can be applied to thermally sensitive substrates. The mechanism of the reaction is similar to that of the Stille and Suzuki couplings. Oxidative addition of the organic halide gives a Pd(II) intermediate that undergoes transmetalation with the alkynyl copper (generated from the terminal alkyne, base, and copper iodide). Reductive elimination with coupling of the two organic ligands gives the product and regenerates the Pd(0) catalyst.

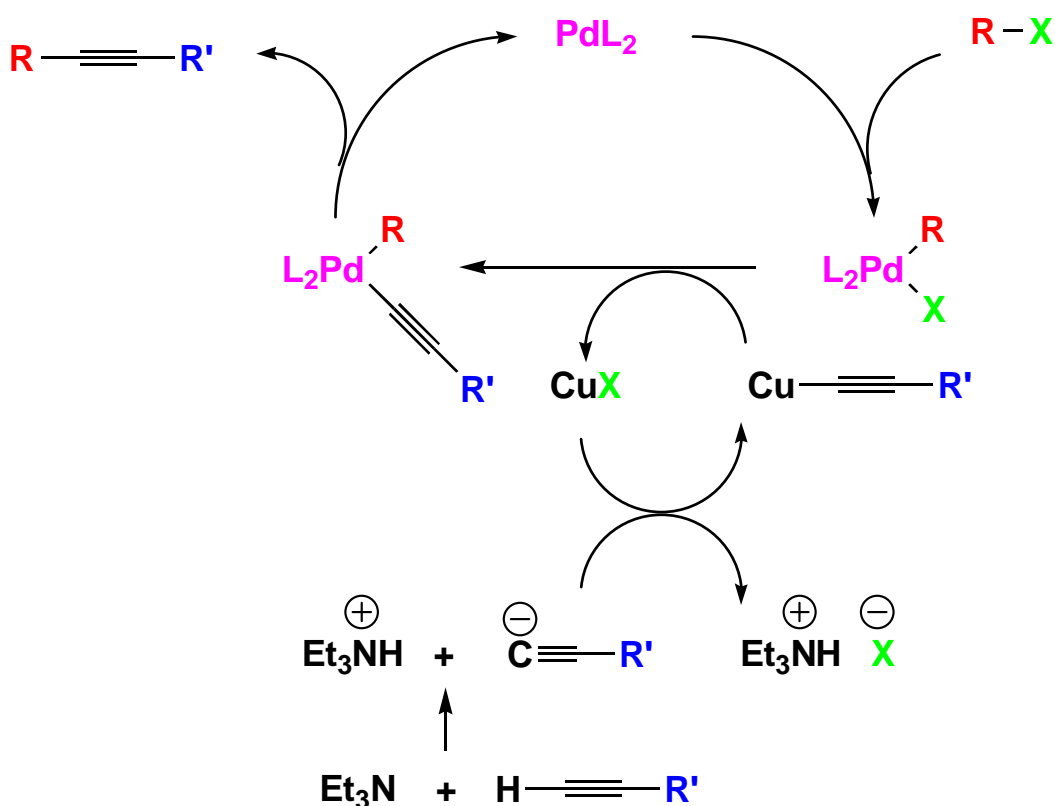

As in the Heck reaction, It is often more convenient to use a stable and soluble Pd(II) source such as Pd(PPh₃)₂Cl₂ instead of Pd(0). This precursor is rapidly reduced *in situ* to give a coordinatively unsaturated, catalytically active, Pd(0) species. The geometry of the alkene is generally preserved so that *cis* (*Z*) and *trans* (*E*) dichloroethylene give the two different geometrical isomers of the enyne below in >99% stereochemical purity as well as excellent yield.

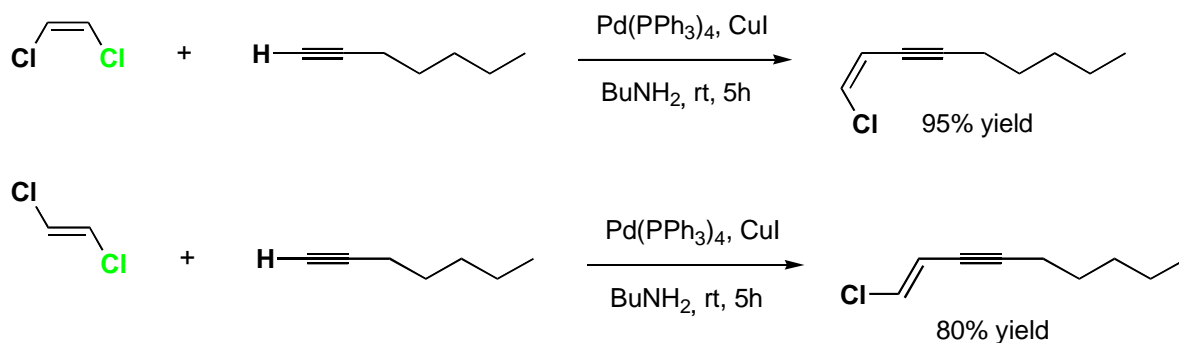

Polymerization & Metathesis

Polymerization is the reaction of an unsaturated organic reactant, typically a C=C, with itself over and over again to produce a polymer chain:

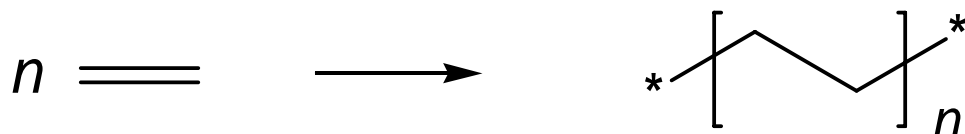

When only a few alkenes couple together to make a short chain, we refer to that as **oligomerization** (oligomers are very short polymers).

There are typically three parts to most polymerizations:

Initiation: generating the active catalyst from a less active catalyst precursor

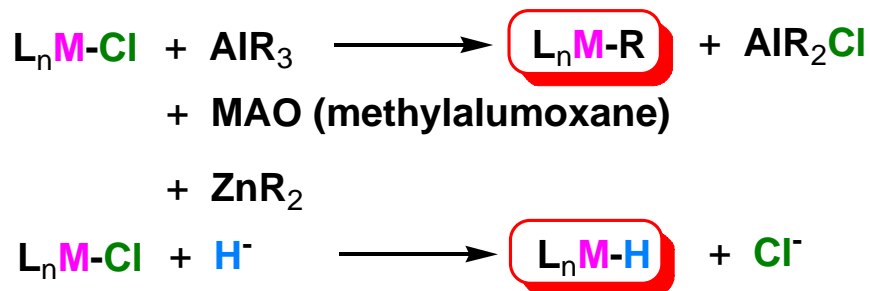

Propagation: the polymer chain growth portion of the reaction that occurs over and over again

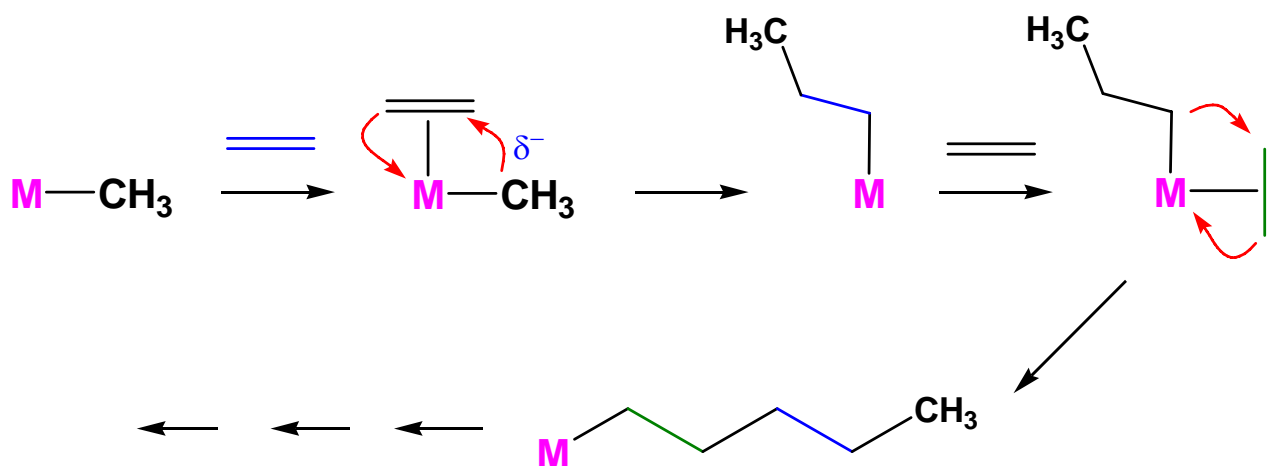

Termination: a reaction step that stops the polymer chain growth

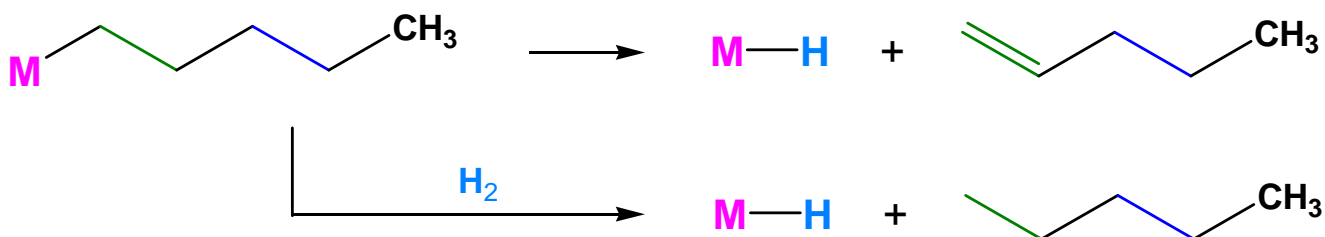

In a good polymerization catalyst the initiation step generates as much active catalyst as possible and the propagation step occurs as often as possible, while the termination step is unlikely to happen. For early transition metal catalysts the β -hydride elimination step that can cause termination is not that favorable.

A **Living Catalyst** is typically a polymerization catalyst in which all the transition metal complexes present are the same and already in an active catalytic state (no initiation step). When the substrate is added all the catalyst molecules start the polymer chain growing steps at the same time and same rate. This means that at any point the polymer chains growing off each and every catalyst are all essentially the same length. This leads to polymers that have a M_w/M_n value very close to 1.0.

What is M_w/M_n ? The average molecular weight of a polymer can be defined by M_n and M_w . M_n is the simple average of total mass of the chains divided by the number of chains. The weight average molecular weight M_w is the summation of the *square* of the molecular weights divided by the summation of the molecular weights of all the molecules present. In M_w more "weight" is provided to the higher molecular weight polymers, while M_n treats all of them the same. The basis for M_w is that the larger molecules contribute more to the properties of the polymer so they should have more importance. M_w is always greater than M_n and the narrower the distribution, the closer M_n and M_w are. The ratio of M_w to M_n is a measure of the distribution of different length polymer chains. This ratio is referred to as the **dispersivity**. As the distribution narrows, the dispersivity approaches a minimum value of 1.0. Such a polymer referred to as **mono disperse**. Alternately as M_w/M_n for a polymer increases (10 or 20) it is referred to as **poly-disperse**. A standard (narrow) Schultz-Flory statistical M_w/M_n polymer distribution is equal to 2.0.

Some History: Ziegler-Natta Polymerization Catalysis

The German chemist Karl Ziegler (1898-1973) discovered in 1953 that when $\text{TiCl}_3(\text{s})$ and AlEt_3 are combined together they produced an extremely active *heterogeneous* catalyst for the polymerization of ethylene at atmospheric pressure. Giulio Natta (1903-1979), an Italian chemist, extended the method to other olefins like propylene and developed variations of the Ziegler catalyst based on his findings on the mechanism of the polymerization reaction. The Ziegler-Natta catalyst family includes halides of titanium, chromium, vanadium, and zirconium, typically activated by alkyl aluminum compounds. Ziegler and Natta received the Nobel Prize in Chemistry for their work in 1963.

The following is a short excerpt taken from Luigi Cerruti (International Journal for Philosophy of Chemistry, 1999, vol 5, 3-41) on the initial work on the oligomerization and polymerization of ethylene:

In June 1953, they [Ziegler's research group] investigated chromium, whose compounds gave some butene but also a small amount of material with high molecular weight. This result was encouraging. At the end of October, Breil, another of Ziegler's collaborators, came to zirconium: a rapid and complete polymerization occurred. Moreover, the infrared spectra demonstrated that the polymer was *linear*. When the turn of titanium came up, the result was again striking. The reaction was so fast that the vessel became hot, and the product was partially decomposed. Thus, the problem was passed to Heinz Martin, who was looking for the mildest possible conditions of polymerization. Since it was apparent that the system Ti/Al-alkyl was very active, Martin tried the simplest possible conditions: no higher pressure at all and no external heating (Ziegler *et al.* 1955b, 543-544). The result of the trial was that Martin burst in Ziegler's office waving a glass flask and crying: "*Es geht in Glass!*"

The third generation of Ziegler-Natta catalysts were developed in 1960 with Shell's patent for a heterogeneous catalyst for propylene polymerization based on TiCl_4 supported on MgCl_2 . Montecatini and Mitsui independently patented catalysts prepared from TiCl_4 , MgCl_2 and an electron donor, and activated by a mixture of trialkyl-Al with another electron donor in 1968. Industrial plants based on these catalysts came online in the 1980's. These third generation catalysts brought a 50-fold increase in activity, so much so that the *removal* of the catalyst from the final product was no longer necessary.

Cossee (migratory insertion) vs. Green-Rooney (alkylidene metallacycle) Propagation Mechanisms

The commonly accepted mechanism for polymer chain growth on a transition metal catalyst is the very simple migratory insertion mechanism initially proposed by Piet Cossee (Royal Shell labs) in 1964.

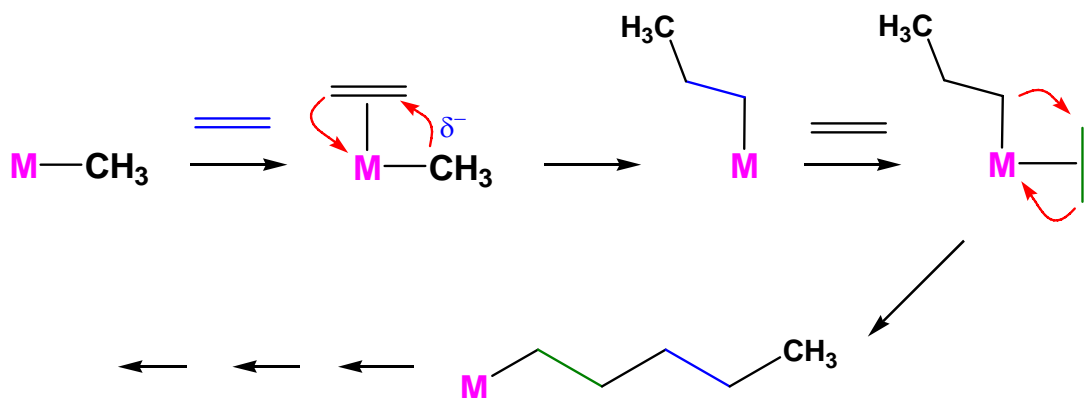

However in 1978 Malcolm Green and John Rooney proposed a rather different mechanism based on the recently reported Schrock alkylidenes:

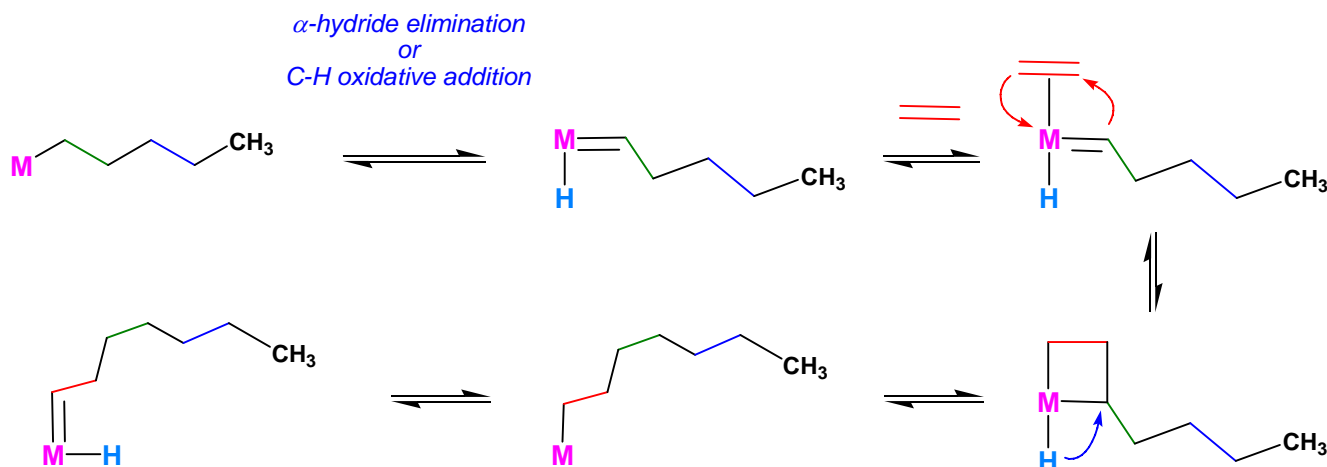

At the time this mechanism was very “sexy” since alkylidenes were relatively new and quite the “rage”. A number of organometallic researchers performed some rather elegant mechanistic studies to figure out which mechanism was operating in a variety of polymerization catalysts.

One of the simplest studies involved the use of deuterated ethylene mixed with regular ethylene:

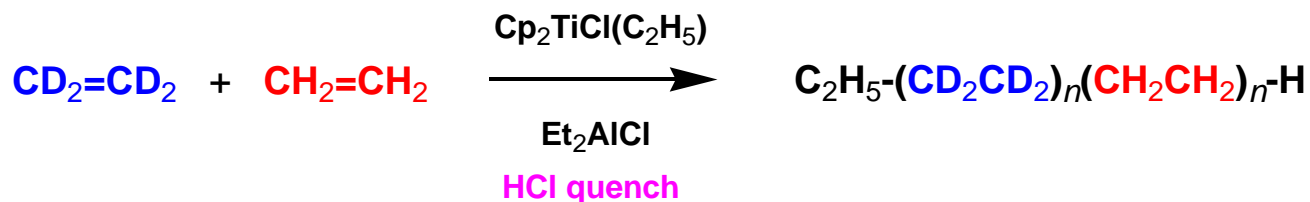

If the migratory insertion mechanism was working, one should *NOT* get any scrambling of the deuteriums and hydrogens in the polyethylene chain (easily confirmed by ^1H and ^2H NMR). However, if the polymerization was working by the Green-Rooney metallacycle mechanism, the α -hydride elimination and subsequent H-alkyl reductive elimination steps would lead to some scrambling of the H and D atoms. But no H/D scrambling was observed, leading to conclusion that the polymerization was NOT working via the alkylidene-metallacycle mechanism, supporting the simpler migratory insertion pathway.

Patricia Watson at Dupont performed another elegant study in 1984 using deuterium labeling:

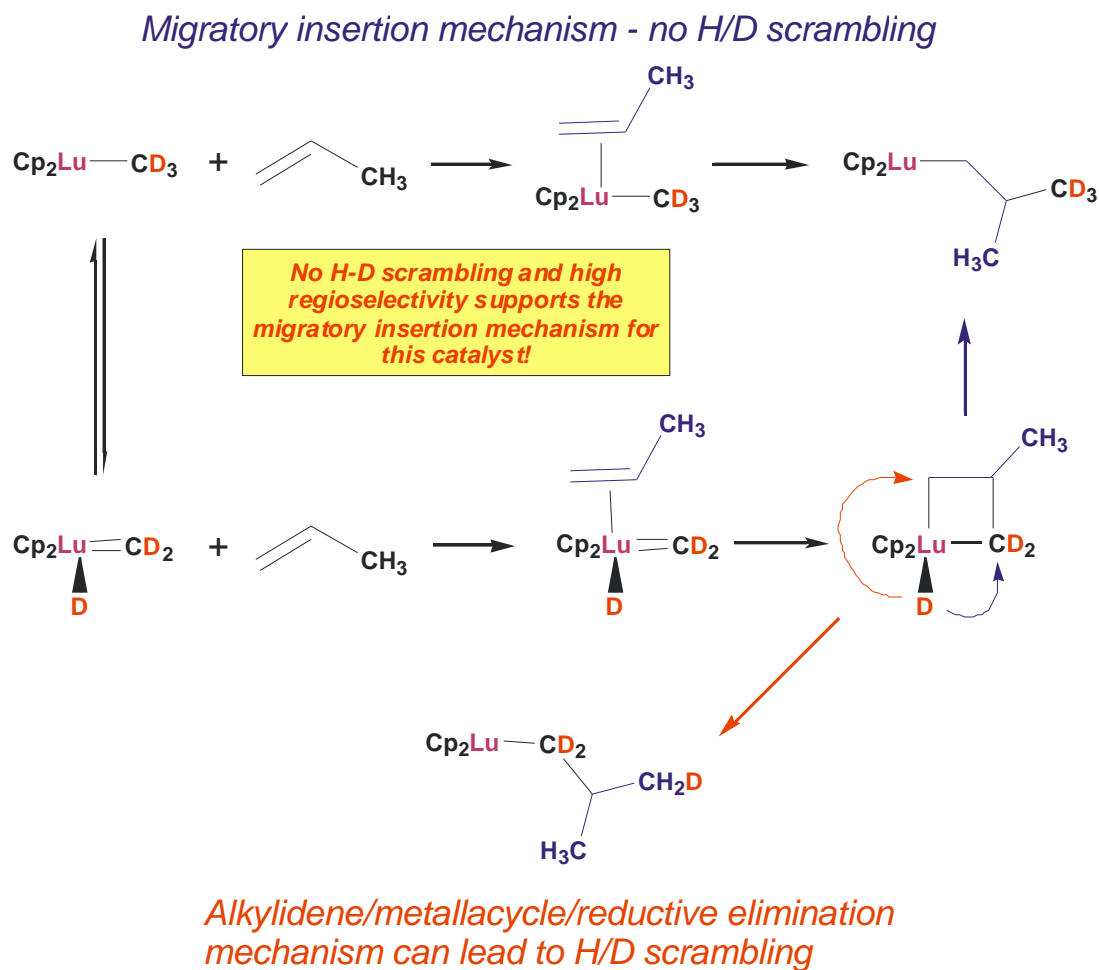

The bottom line is that most mechanistic studies have clearly pointed to the **migratory insertion** mechanism, certainly for the highly active Group IV metals (Ti & Zr), for the lanthanides and actinides, and the new late transition metal systems discovered by Brookhart and Gibson.

One proven exception is Schrock's Ta alkylidene living catalyst that is believed to work via the metallacycle mechanism:

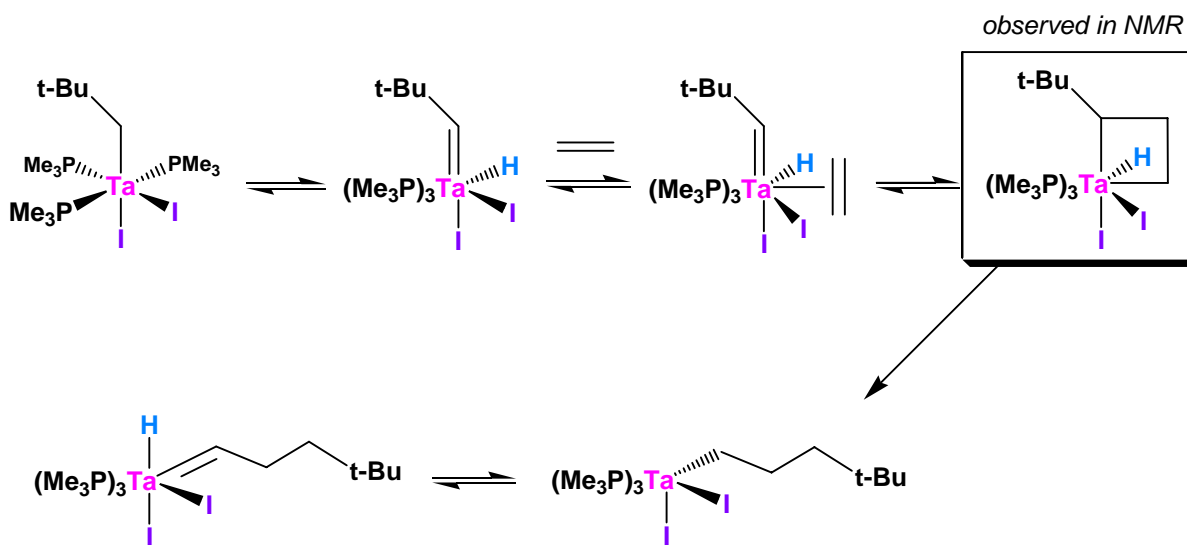

An interesting aspect of the migratory insertion reaction is that the most active polymerization catalysts typically need to have an extra empty orbital after the coordination of the alkene to the M-alkyl unit. Bercaw has proposed that this is because the alkyl group needs to form an agostic C-H bond interaction with the empty orbital on the metal to tilt the localized sp³ alkyl orbital away from the metal and more towards the alkene ligand to promote the migratory insertion. A transition-state structure from a quantum mechanical calculation showing this interaction is shown above.

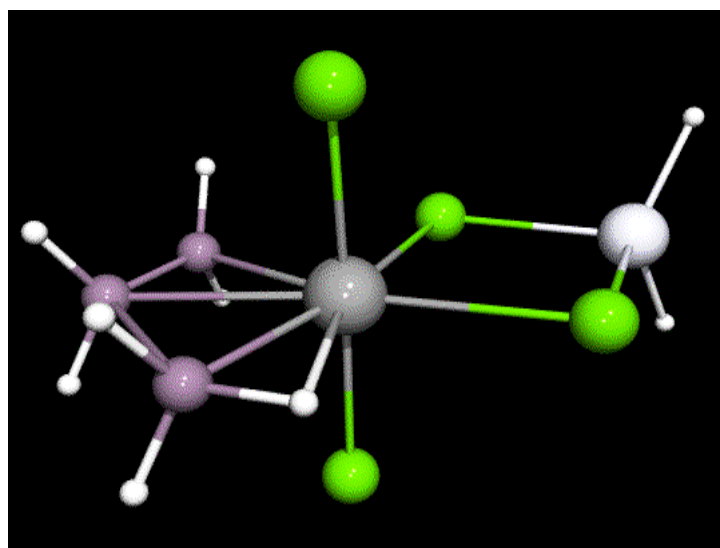

Polypropylene & Stereochemistry

The polymerization of propylene is slower and more complicated than ethylene due to increasing steric factors and the generation of stereochemistry on the polymer chain:

isotactic

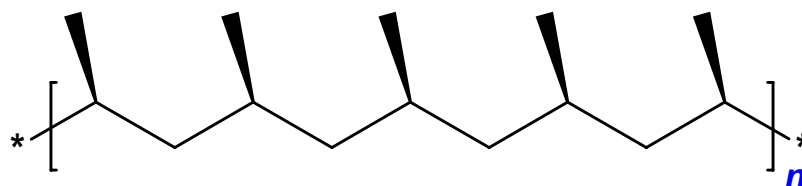

syndiotactic

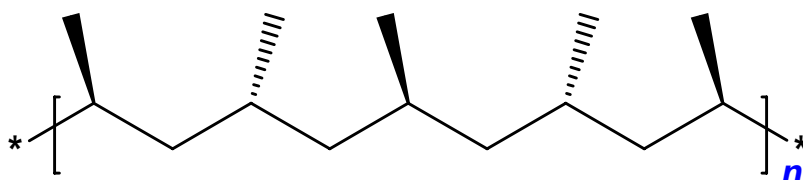

atactic (random)

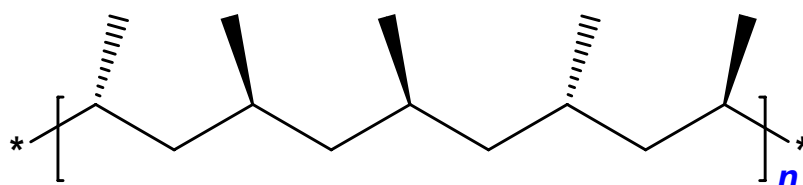

The steric environment around the metal center has a DRAMATIC impact on what kind of stereochemistry one obtains.

C_2 symmetry (chiral) - Isotactic polymer

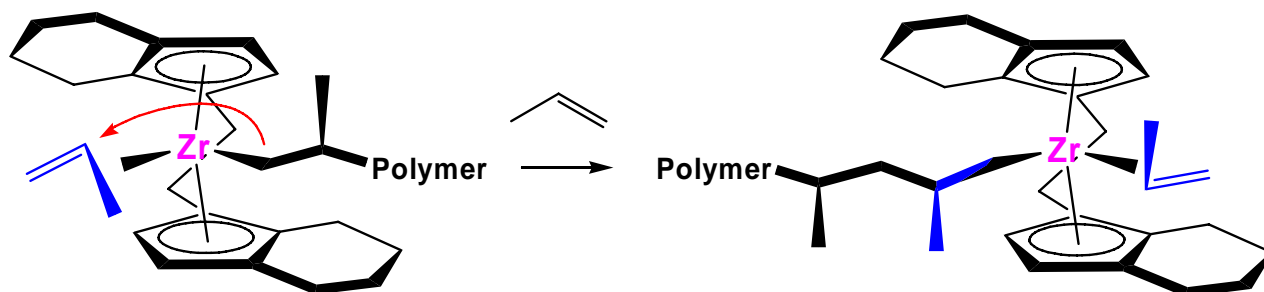

Bulky-Small Catalyst environment - Syndiotactic polymer

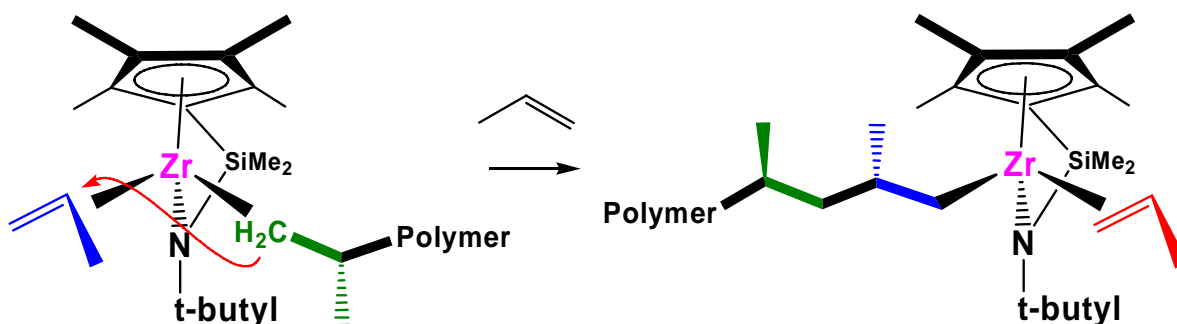

A catalyst with small ligands that offer little steric directing effect, like Cp_2TiCl_2 , will generate **atactic** polypropylene.

In 1985 Walter Kaminsky discovered that the combination of methylalumoxane and the Zr catalyst shown below generated a highly active catalyst for isotactic polypropylene.

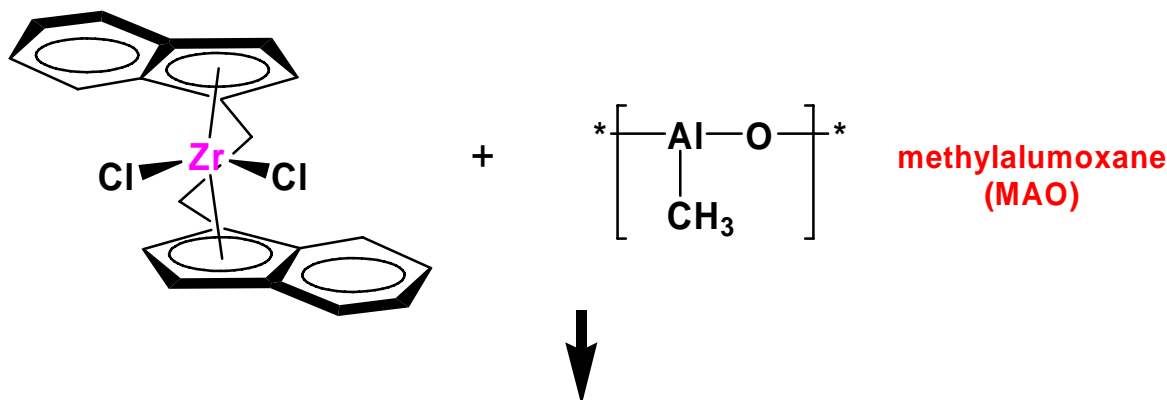

Almost as active as Ziegler-Natta hetero catalyst

> 95% isotactic polypropylene

High MW and narrow polymer MW distribution (semi-living catalyst)

meso isomer gives atactic polypropylene

Some History: Kaminsky, Bercaw & Metallocene Polymerization

The fourth generation of polymerization catalysts, based on metallocene compounds, is now evolving towards industrial success. Their origin is very interesting, because it was “accidental.” Kaminsky has described the incident with these words:

“An accident in our laboratory in 1976 brought about equimolecular amounts of water into the system compared to the trimethylaluminum, and, surprisingly, an unusual high polymerization activity of ethylene was observed.”

Kaminsky and Sinn suspected that the water and AlEt_3 reacted to form methylaluminumoxane (MAO), and they subsequently discovered that MAO-activated *homogeneous* metallocene catalysts were capable of polymerizing propene and higher olefins. This seminal discovery by Kaminsky and Sinn started the search for **single-site** catalysts.

Late Transition Metal Polymerization Catalysts

Well characterized Group 8 polymerization catalysts were reported by Brookhart in 1998 (*J. Am. Chem. Soc.* **1998**, *120*, 4050) and Gibson in 1999 (*J. Am. Chem. Soc.* **1999**, *121*, 8728.). These catalysts operate via the simple Cossee alkene addition and migratory insertion mechanism.

A key in preparing an efficient polymerization catalyst was the realization that the facile β -hydride eliminations occurring on Group 8 metals (especially Ni and Pd) lead to an **associative displacement problem** that short circuited the chain growth pathway. When a growing polymer alkyl chain does a β -hydride elimination from a 3-coordinated catalyst species, a 4-coordinate hydride-alkene is formed.

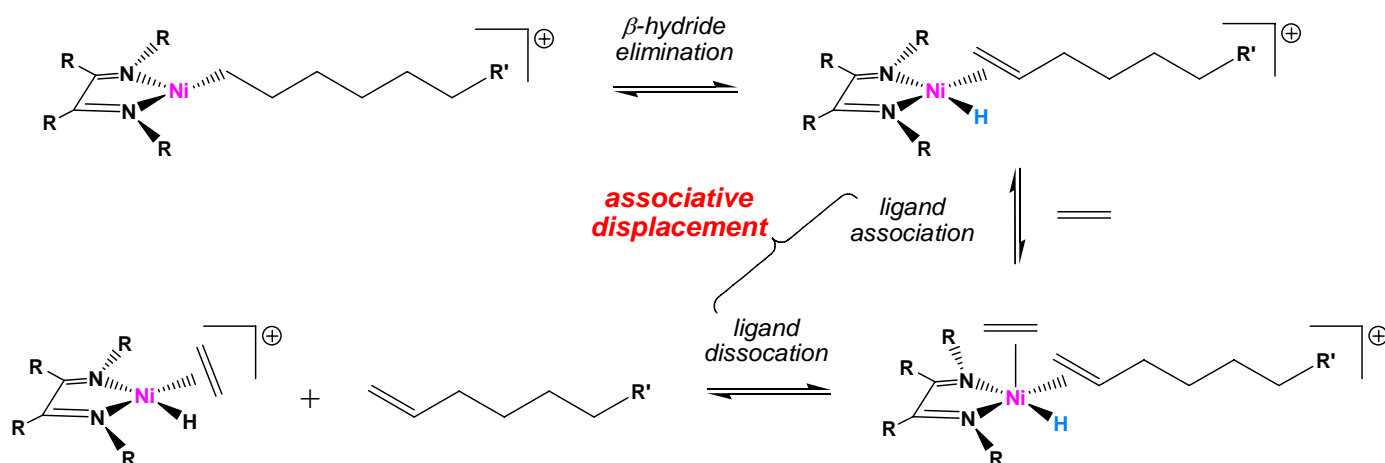

A small ethylene can easily coordinate to the axial metal site leading to a less stable 5-coordinate complex. This promotes loss of the longer alkene chain leading to termination of the chain growth. By placing extremely bulky R-groups on the diimine ligand, Brookhart was able to effectively block both axial coordination sites while still allowing equatorial alkene coordination.

An unusual aspect of Brookhart's Ni and Pd polymerization catalysts was that they could produce highly branched polyethylene, with the amount of branching controlled in large part by the ethylene pressure. Mechanistic studies indicated that facile β -hydride eliminations on these catalysts under lower ethylene pressures enabled a "**chain-walking**" isomerization process shown below. This leads to branching (sometimes extensive) of the growing polymer chain. Under higher ethylene pressures, the empty coordination site needed for β -hydride elimination is more rapidly filled by an ethylene leading to more linear chain growth.

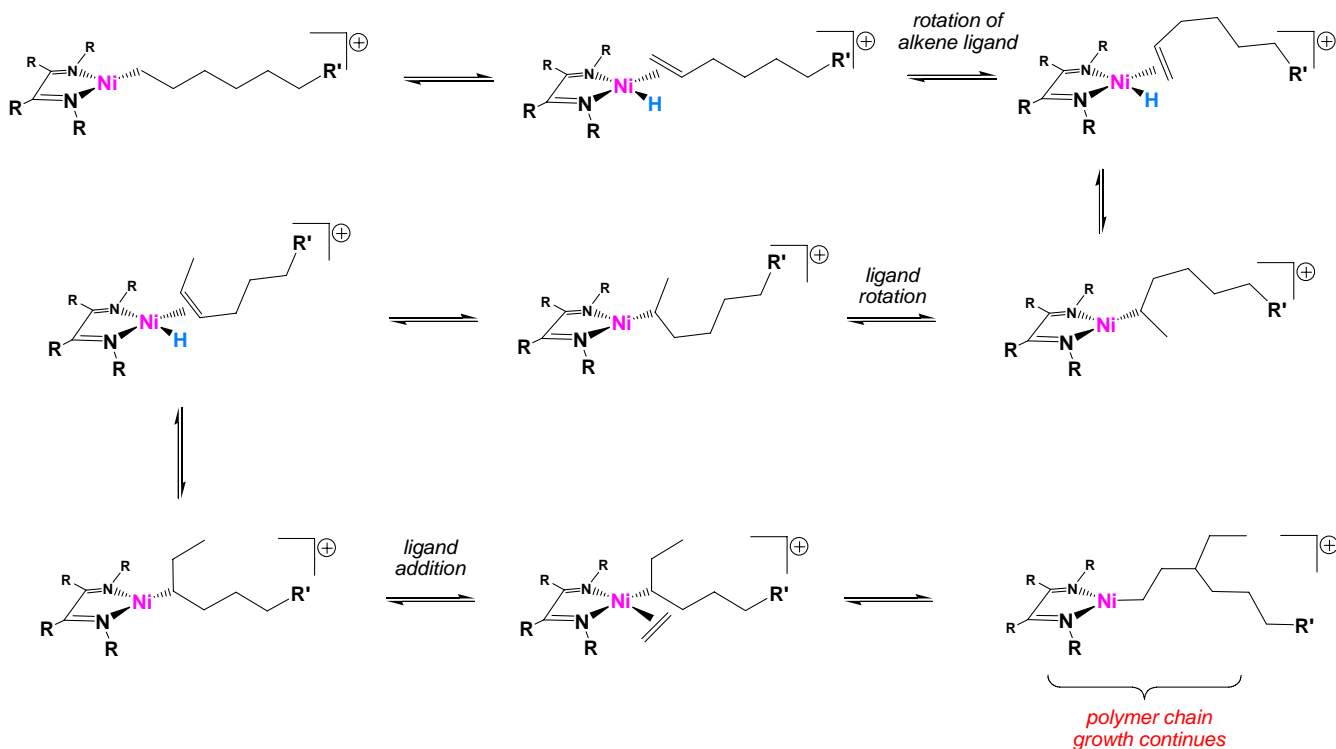

Metathesis

Metathesis catalysis refers to the reaction of two unsaturated substrates (typically alkenes or alkynes) that leads to a switching of the atom groups on each end of the bond with the unsaturation. This is shown below for the reaction of two C_8 dienes.

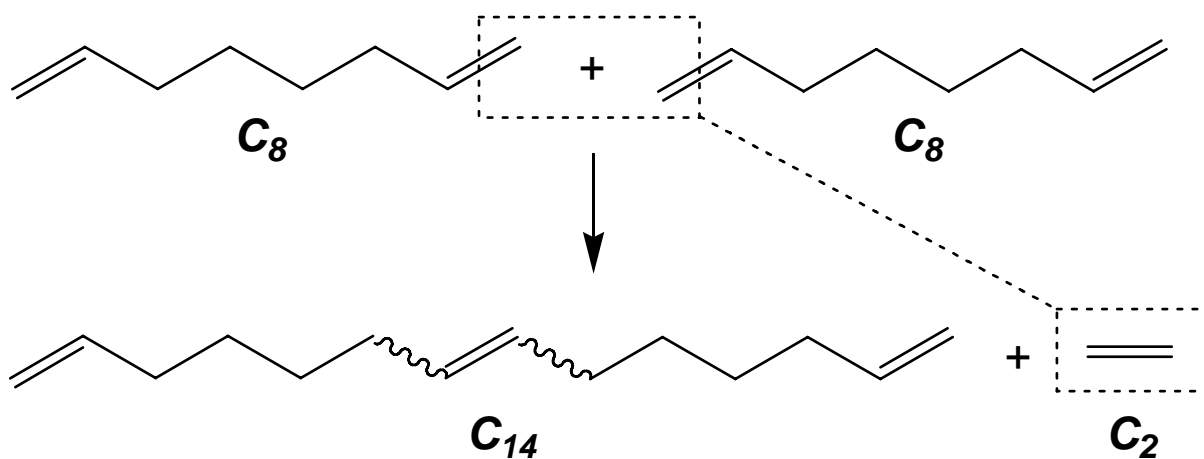

The proposed mechanism for this involves metal-alkylidenes and is shown below:

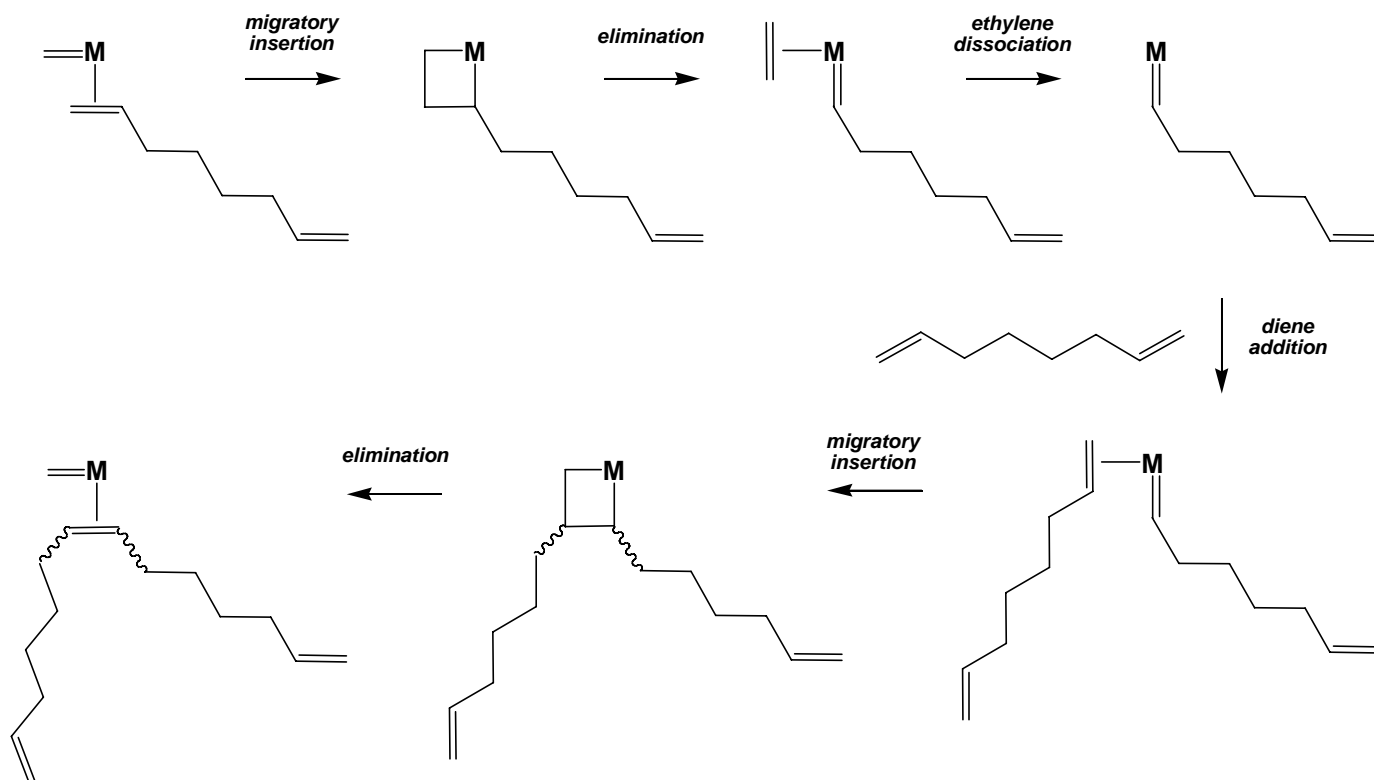

Carrying this reaction out over and over with the more reactive terminal double bonds leads to **acyclic diene metathesis (ADMET)** polymerization with longer chain α,ω -diene substrates. The general reaction relies on the loss of ethylene from the reaction mixture to drive the reaction to high couplings and molecular weights. The internal double bonds generated are not as reactive as the terminal double bonds for the metathesis reaction.

Ring opening metathesis polymerization, ROMP, (Schrock, R. R., *Acc. Chem. Res.* **1990**, *24*, 158. Grubbs, R. H.; Tumas, W., *Science*, **1989**, *243*, 907) is another mechanism for polymerization related to the Green-Rooney alkylidene pathway that can operate when one deals with cyclic alkenes. The first commercial product using ROMP was prepared by CdF Chimie from norbornene using a heterogeneous catalyst based on MoO_3 supported on alumina.

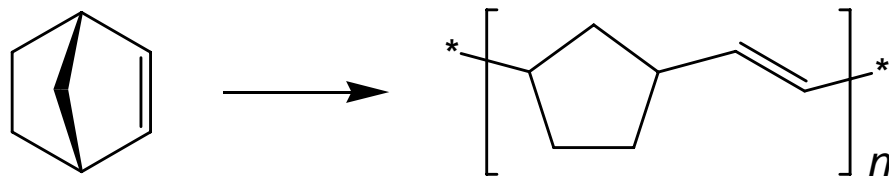

ROMP works best on cyclic alkenes that have some ring strain to drive the ring opening process and minimize possible ring closing reactions. A proposed mechanism for the ROMP of norbornene using a Cp_2Ti center is shown below. In this mechanism one considers the alkylidene as a dianionic ligand, so the reaction with the alkene is considered a **migratory insertion**. The subsequent elimination reaction can proceed in two ways, backwards (non-productive) and forward, which opens the norbornene ring and extends the polymer chain.

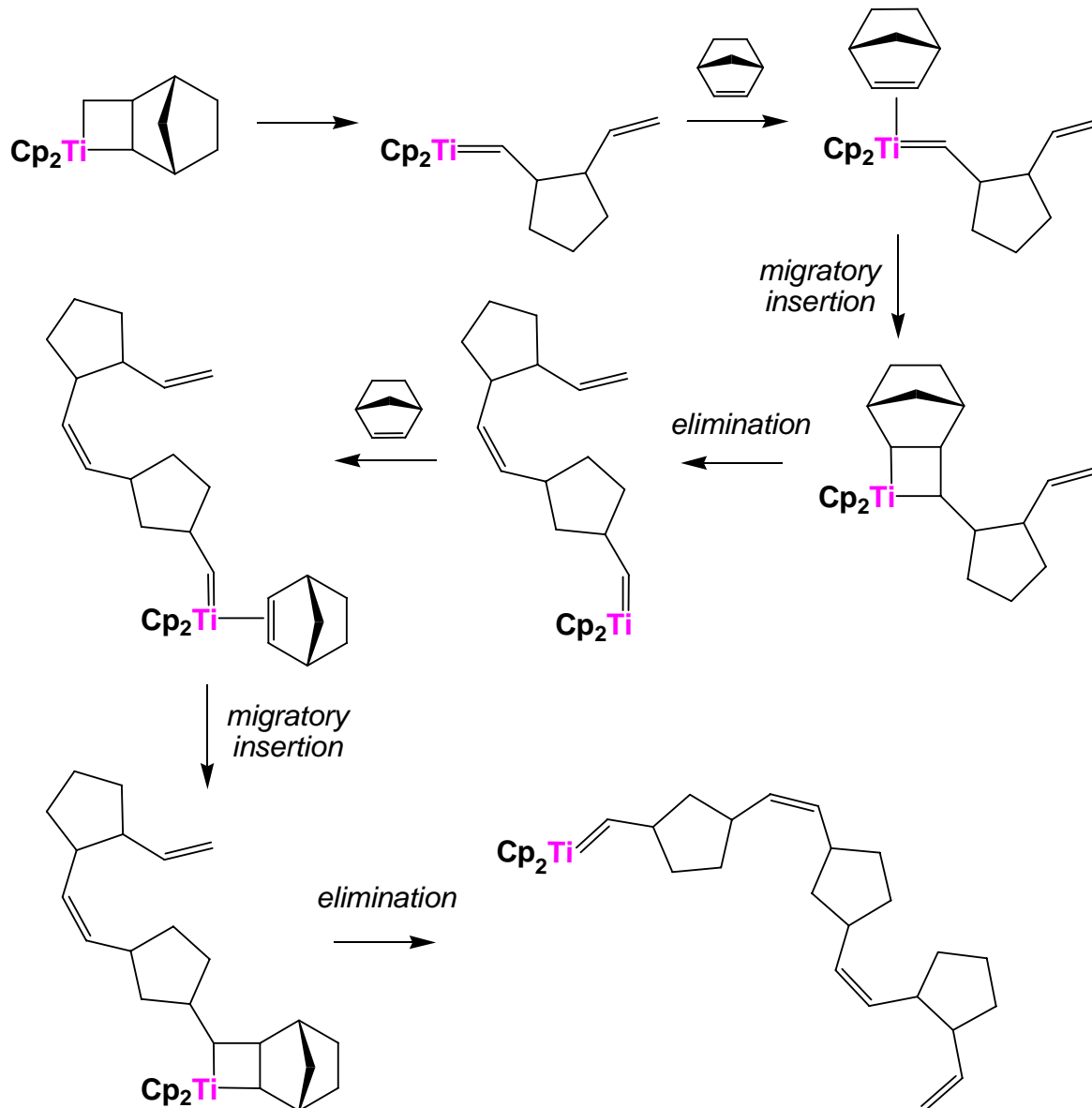

Homeworks

for the last 2 years

Followed by **Answer Keys**

Organometallic Chemistry - 4571

Name: _____

Homework # 1: Due: Feb 12, 2004 (2 PM)

Group: _____

Check the box to the right if you want your graded homework to be placed out in the public rack outside Prof. Stanley's office. Otherwise you will have to pick up your homework from Prof. Stanley in person:

1. (38 pts) Sketch out a structure showing the geometry about the metal center as accurately as possible and clearly show the electron counting for the complexes below. Phosphine ligand abbreviations are defined in your notes (phosphine ligand section). Molecules (some simplified) are from *Organometallics*, **2004**, # 1 & 2, from the Chem Library or on-line at the Library E-Journal site (only from a campus computer). Note that I am using the author's formulas in some cases that use both the κ - and η -notations for ligand connectivity.

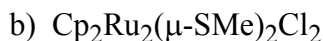
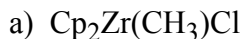

(heterobimetallic complex, count both metals)

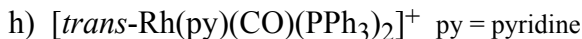
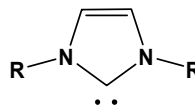
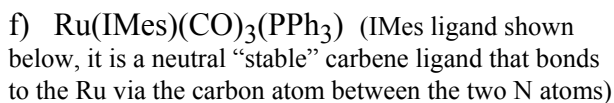
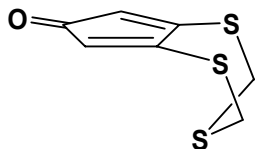
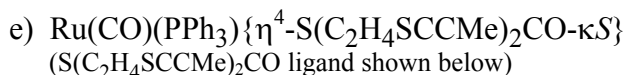

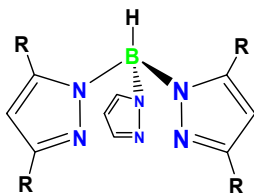
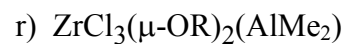
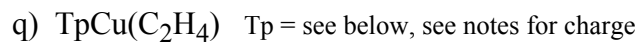
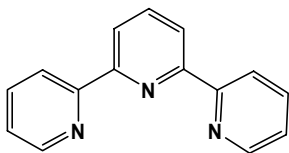
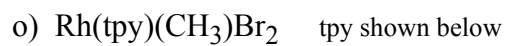
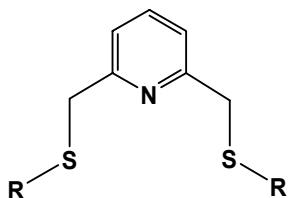
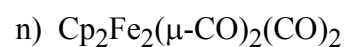
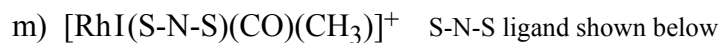
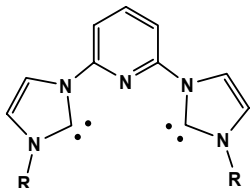
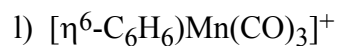
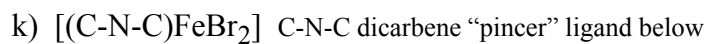
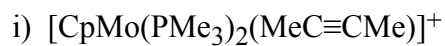

2. (12 pts) Propose an **18e- structure** for the following metal/ligand combinations. Use at least one of each metal and ligand listed. Complexes must be neutral. Don't use more than 2 metal centers. Clearly show your electron counting. Ligands are shown without charges, please indicate the proper ligand charge in your electron counting. Draw a reasonable structure showing the geometry about the metal center(s).

a) Ir, Cp, C≡NMe

b) Zr, NR₂, CR₂, PMe₃

c) Mo, Cp, CH₃, N≡CMe

d) Pt, dmpm (bridging), μ-CO (only one), CO

Organometallic Chemistry - 4571

Name: _____

Homework # 1: Due: February 17, 2005

Group: _____

1. (38 pts) Sketch out a structure showing the geometry about the metal center as accurately as possible and clearly show the electron counting for the complexes below. Phosphine ligand abbreviations are defined in your notes (see the phosphine ligand section). All the molecules (some simplified) are from *Organometallics*, **1999**, 18 (#24), which you can find in the Chemistry Library or on-line at the Library E-Journal site (only accessible from a campus computer). Phosphine ligand abbreviations are in your notes.

See page Lewis 5 in your notes

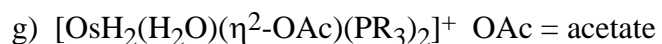
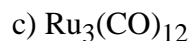
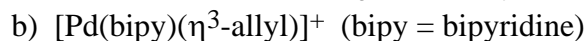

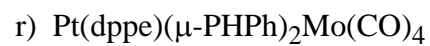
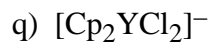
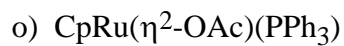
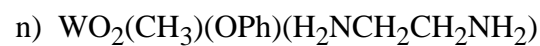
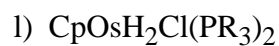
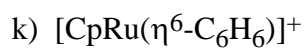

2. (12 pts) Propose an **18e- structure** for the following metal/ligand combinations. Use at least one of each metal and ligand listed. Complexes should be neutral. Don't use more than 2 metal centers. Show your

electron counting. Ligands are shown without charges, please indicate the proper ligand charge in your electron counting. Draw a reasonable structure showing the geometry about the metal center(s).

a) Ta, NMe, NMe₂, N≡CCH₃

b) Re, CO, PMe₂ (bimetallic complex)

c) Os, allyl, O

d) Mn, CO (no bridging CO's)

Organometallic Chemistry - 4571

Name: _____

HW # 2 Due: March 25 (by 2 PM!), 2004

Group: _____

Check the box to the right if you want your graded homework to be placed out in the public rack outside Prof. Stanley's office. Otherwise you will have to pick up your homework from Prof. Stanley in person:

1. (18 pts) For each of the following pairs of metal complexes, circle the one that should have the lowest average carbonyl IR stretching frequency. What does this tell you about the relative electron density on the metal center (electron-rich or deficient)? Briefly discuss your reasoning for each case.

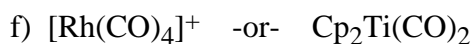
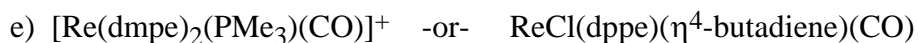
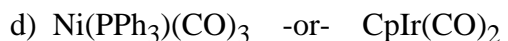
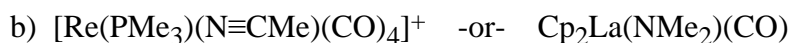

2. (18 pts) For each of the following pairs of metal hydride complexes, circle the one that should have the lowest pK_a value. Briefly discuss your reasoning for each case.

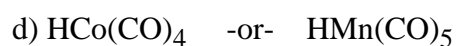
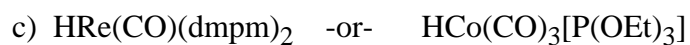
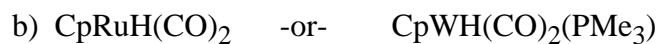
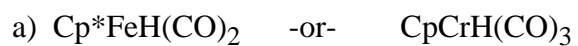

3. (8 points) Compare the methyl isocyanide ($\text{C}\equiv\text{NCH}_3$) ligand to $\text{C}\equiv\text{O}$ (carbonyl) with regards to its σ donor ability and π -backbonding ability. Discuss. Clearly explain the origin of any differences in metal-ligand bonding between the two ligands.

4. (6 points) Circle the correct ordering of the following group of carbenes (or alkylidene) from the strongest $\text{M}=\text{CR}_2$ bond to weakest. Clearly explain your reasoning.

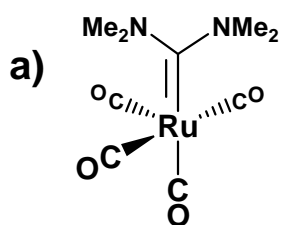

d > b > c > a

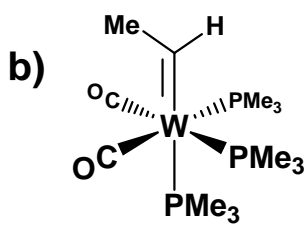

b > c > d > a

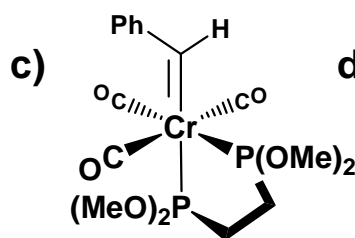

d > c > b > a

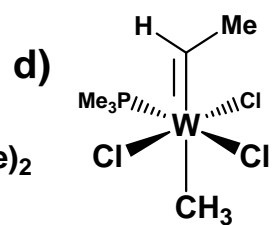

c > a > d > b

Organometallic Chemistry - 4571
HW # 2 Due: March 17 (by 1PM!), 2005

Name: _____

Group: _____

Check the box to the right if you want your graded homework to be placed out in the public rack outside Prof. Stanley's office. Otherwise you will have to pick up your homework from Prof. Stanley in person:

1. (20 pts) For each of the following pairs of metal complexes, circle the one that will have the highest CO stretching frequency. Briefly discuss your reasoning for each case.

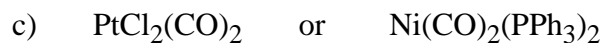
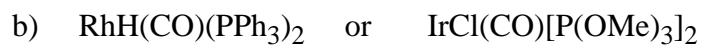
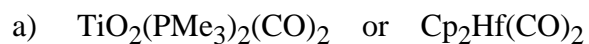

2. (20 pts) For each of the following pairs of metal hydride complexes, circle the one that should have the lowest pK_a value. Briefly discuss your reasoning for each case.

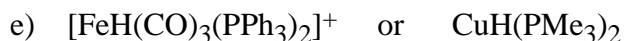
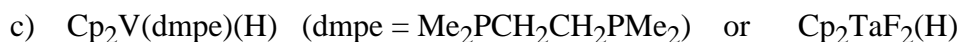

4. (10 pts) Aside from CO, what other ligands mentioned in the big ligand table (Intro 15-20) in your notes can act like π -backbonding (or π -acceptor) ligands and would have easily monitored IR stretching frequencies (in the $2800\text{-}1600\text{ cm}^{-1}$ region) that might prove useful as “sensors” for measuring the amount of electron density (or lack thereof) on a transition metal center? [*Hint*: there are 3 or 4 reasonable choices] Discuss which of these would be the best choice for this and why.

Organometallic Chemistry - 4571

Name: _____

HW # 3 Due: April 15 (by 2 PM), 2004

Group: _____

Check the box to the right if you want your graded homework to be placed out in the public rack outside Prof. Stanley's office. Otherwise you will have to pick up your homework from Prof. Stanley in person:

1. (30 pts) Identify the following reactions by their type (migratory insertion, elimination, oxidative addition, reductive elimination, substitution, ligand addition, β -hydride elimination, ligand coordination change, etc.). Note that in some cases one will have to use more than one description for a reaction which may have several steps and the order may be important. No discussion is necessary.

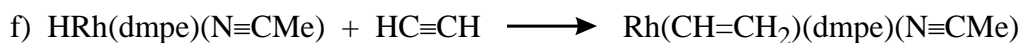
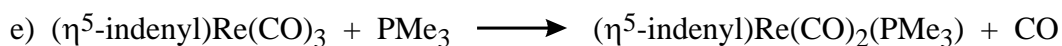
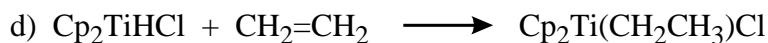
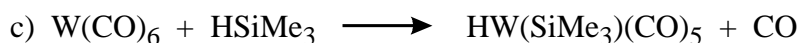
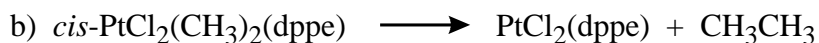
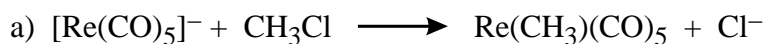

2. (30 pts) For each pair of complexes shown below, circle the one that should be the most reactive towards the oxidative addition of the reactant indicated. Give a brief explanation for your choice.

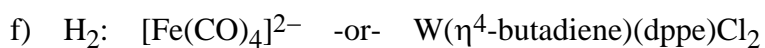
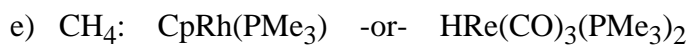
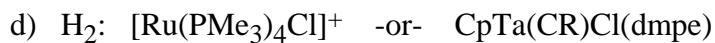
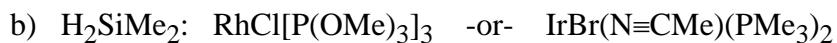
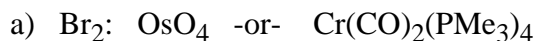

3. (20 pts) Olefin metathesis involves the following steps that I've labeled using one method of electron counting. The dashed vertical line through the metallocyclobutane ring illustrates which way that ring is breaking for the following step.

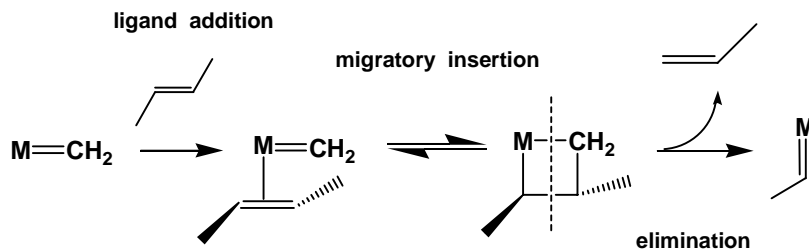

- a) (10 pts) Which way am I electron counting the $M=CR_2$ unit – as a neutral carbene or dianionic alkylidene? Briefly and clearly explain.
- b) (10 pts) How would you label these three steps if one treated the $M=CR_2$ unit the other way from how I assigned it above? Briefly and clearly explain.
4. (20 pts) Consider the following catalytic cycle. Label each step in the boxes provided with the reaction step(s) that is (are) occurring. Some steps may have more than one fundamental reaction, if so list each one in the correct order if the order is important.

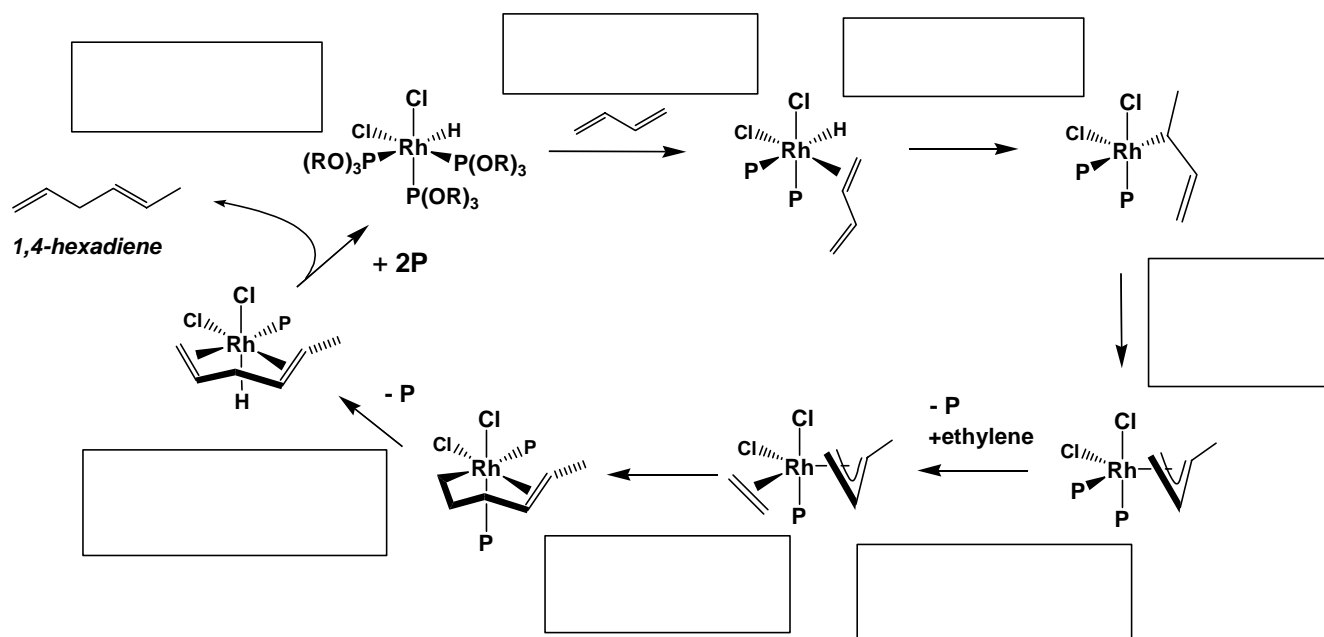

Organometallic Chemistry - 4571

Name: _____

Homework # 3 (Due: April 14, 2005)

Group: _____

Check the box to the right if you want your graded homework to be placed out in the public rack outside Prof. Stanley's office. Otherwise you will have to pick up your homework from Prof. Stanley in person:

1. (40 pts) Identify the following reactions by their type (migratory insertion, elimination, oxidative addition, reductive elimination, substitution, ligand addition, ligand dissociation, β -hydride elimination, ligand coordination change, etc.). Note that one may have to use more than one description for a reaction that may have several steps. For reactions with several steps, if the order is important you must list the steps in the correct order.

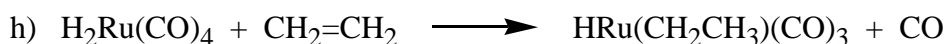
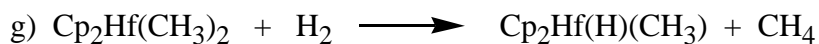
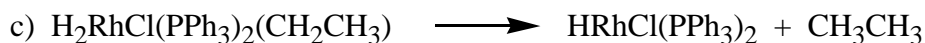
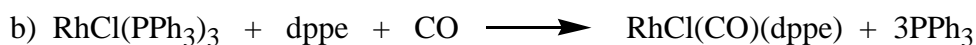
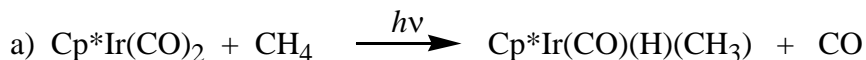

2. (20 pts) Consider the reaction shown below. Clearly describe what is happening. What kind of electronic effect R groups (electron-withdrawing or electron-donating) on the diene ligand will favor formation of the product? Why?

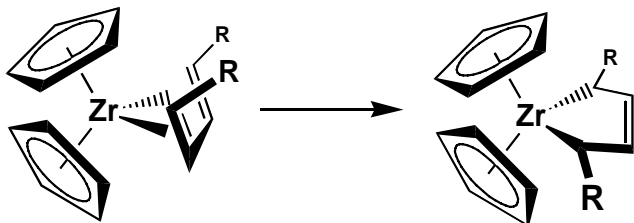

b) Why won't the following complex undergo the same transformation?

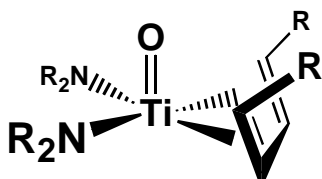

3. (20 pts) Consider the following reaction:



Show in detail each mechanistic step in the conversion to the product species shown. Label and clearly identify each step. The order of the steps may be important – if so list them in the correct order when necessary.

4. (10 pts) Label and clearly identify each step (i.e., migratory insertion, elimination, oxidative addition, reductive elimination, substitution, ligand addition, ligand dissociation, β -elimination, etc.) in the following catalytic reaction (called a Heck arene-alkene coupling reaction). Please write your answer(s) in the box next to the step. If there is more than one step occurring, please list them in the correct order if important. PPh_3 is abbreviated as P for most of the complexes in the diagram.

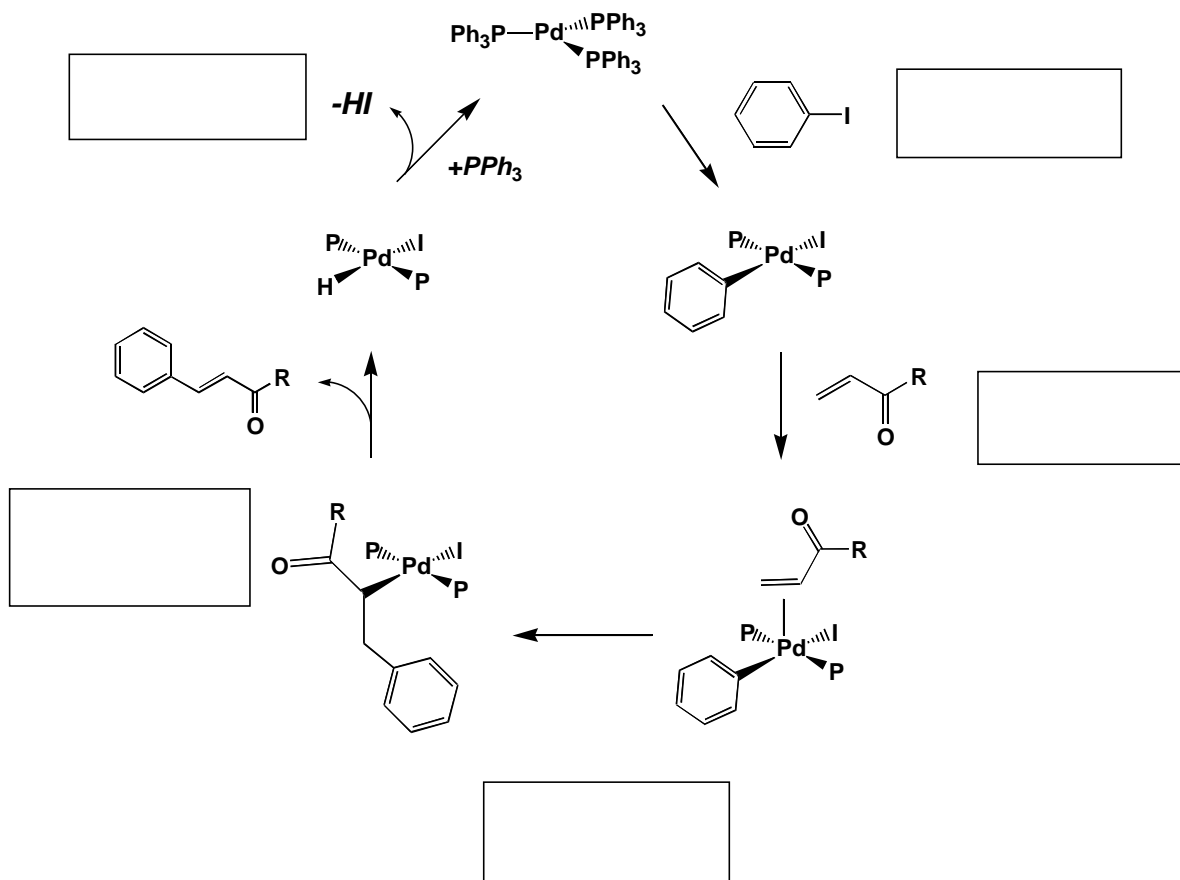

5. (10 pts) Which of the following products will be the most likely formed from the reaction shown. Circle the best choice and give a brief explanation/justification for your choice.

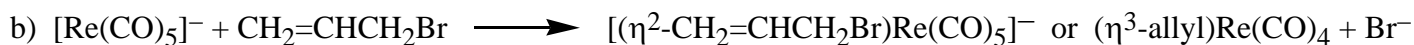

Organometallic Chemistry - 4571

Name: _____

Homework # 4 -- Due: May 4, 2004 (by 2 PM)

Group: _____

Check the box to the right if you want your graded homework to be placed out in the public rack outside Prof. Stanley's office. Otherwise you will have to pick up your homework from Prof. Stanley in person:

1. (30 pts) The water-gas shift reaction is the following overall process:

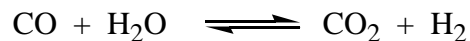

a) (20 pts) Sketch out a catalytic cycle for the water-gas shift reaction that proceeds by the following steps using $\text{Fe}(\text{CO})_5$ as the starting catalyst: 1) nucleophilic attack of OH^- on one of the CO ligands, 2) CO_2 loss (decarboxylation), 3) protonation of Fe, 4) reductive elimination of H_2 , 5) CO ligand addition.

b) (5 pts) The loss of CO_2 from the Fe-carboxylic acid group to make the Fe-H complex isn't technically an elimination reaction as it occurs from an 18e- complex. What is the problem with dissociating a CO ligand first to make a 16e- complex, then doing a formal elimination and dissociation of CO_2 followed by ligand addition of CO to make the 18e- Fe-H complex.

- c) (5 pts) The catalytic cycle described in part A) has a reductive elimination step, but no step formally labeled oxidative addition. What step is actually an oxidative addition and why?

2. (20 pts) Sketch out and label a reasonable catalytic cycle for the following reaction called hydrovinylation:

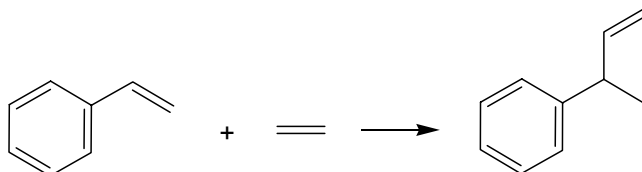

Start the cycle using the catalyst $\text{NiHCl}(\text{PCy}_3)$ (shown below), clearly sketch out each complex with reasonably accurate structures, and clearly label each reaction step. The first step is styrene ligand addition.

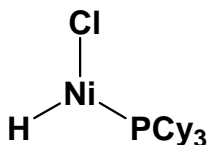

Read the attached *JACS* communication (*J. Am. Chem. Soc.*, 2004, 126, 4526-4527) and answer the following questions.

5. (5 pts) Sketch out the structure of the triflate anion (abbreviated OTf in the paper). Is this a strongly coordinating anion? Do you think it stays coordinated to the Au during catalysis? Discuss.

6. (15 pts) Consider the following table of catalytic data from the paper:

Table 1. Efficiency of Group XI Metal Catalysts in the Conia-Ene Reaction



entry	conditions	time	% conv. to 2 ^a
1	10 mol % AgOTf, DCE, rt	18 h	50
2	10 mol % AgOTf, 10 mol% PPh ₃ , DCE, rt	18 h	0
3	10 mol % AuCl ₃ , DCE, R.T.	30 min	30 ^b
4	10 mol % (PPh ₃)AuCl, DCE, 60 °C	6 h	0
5	10 mol % (PPh ₃)AuOTf, DCE, rt	<15 min	>95
6	10 mol % [(CyNC) ₂ Au]PF ₆ , DCE, rt	14 h	0
7	1 mol % [PPh ₃ Au] ₃ O]BF ₄ , DCE, 60 °C	1 h	0
8	1 mol % [PPh ₃ Au] ₃ O]BF ₄ , 5% HOTf, DCE, rt	<15 min	>95

^a As judged by ¹H NMR. ^b No starting material (1) remained.

(a) (6 pts) What is the theoretical turnover number (TO) for experiment # 3 and # 8 in Table 1? Assuming that the % yield is the actual conversion to product (and not just the isolated yield) what is the actual turnover number for experiment # 3.

(b) (4 pts) What is the average turnover frequency for experiment # 3? What is the average turnover frequency for experiment # 8 (assume 10 min reaction time and 95% conversion to product)?

- (c) (5 pts) What does footnote b mean since only 30% of product **2** was observed? (I'm looking for a short simple answer)
6. (10 pts) Based solely on what I have taught you this semester I would have favored mechanism A over B. Clearly discuss why.
7. (10 pts) For the optimized catalyst system used in Table 2 (footnote a), they add 1 mol % of AgOTf. What does this do? Why is the localized cationic charge on the Au generally important for the catalysis?
8. (10 pts) In footnote 13 the authors discuss some of the solvent effects on the catalysis. What does the failure of the catalysis to work in coordinating solvents tell you about the strength of the substrate coordination to the catalyst? Do you think that DMSO would be a good solvent for the catalysis? Briefly and clearly discuss.

Organometallic Chemistry - 4571

Name: _____

Homework # 4 -- Due: May 3, 2005 (by 2 PM)

Group: _____

Check the box to the right if you want your graded homework to be placed out in the public rack outside Prof. Stanley's office. Otherwise you will have to pick up your homework from Prof. Stanley in person:

Read the attached communication from the *Journal of the American Chemical Society* (Louie *et al*, *JACS*, 2002, 124, pg. 15188) and answer the following questions.

- 1. (10 pts) a) (5 pts)** How many theoretical turnovers could the authors do using the information presented in Table 1? Briefly explain.

b) (5 pts) What was the maximum number of turnovers they *actually* performed based on the discussion in the paper (information on first page)? Briefly explain.
- 2. (10 pts)** Is there any important catalytic data missing from Table 1 or the main text of the paper? If there is important missing information, please state what is missing. If none is missing, just say none.
- 3. (10 pts)** In Scheme 1 the authors have $\text{Ni}(\text{L})_n$ indicated as the catalyst, where L = the IPr carbene. What is the likely value of n (1 or 2?) and why?

4. (10 pts) Prof. Louie refers to the reaction of CO₂ and one of the alkyne groups as a 2 + 2 cycloaddition. From an organic viewpoint this is correct. But from an organometallic mechanism viewpoint, what should this reaction be called and why? See the product of this reaction in Scheme 1 labeled **19**.
5. (20 points) The formation of complex **21** in Scheme 1 is not observed using the catalyst with IPr ligand. She does, however, see it when she uses a smaller carbene ligand.
- a) (5 pts) When complex **21** forms using a smaller carbene ligand it does not do a reductive elimination to kick off the organic product. Why not? Draw a structure of the organic product.
- b) (15 pts) Complex **21** (with a smaller carbene ligand) will, however, readily react with acetylene (H-C≡C-H) to produce a new bicyclic organic product. Sketch out and label the steps of the mechanism to convert **21** + acetylene to the free bicyclic organic product. You can use L to indicate the carbene ligand.

6. (20 pts) Sketch out and label the steps needed to take Ni(L)_n (use the n value from question # 3), CO_2 and diyne (use the diyne shown in Scheme 1) to complex **19** (Scheme 1). Based on the discussion in the text the order of CO_2 and alkyne coordination and subsequent “coupling” should be clear.

7. (10 pts) The strong donor ability of the IPr carbene ligand play an important role in this reaction. What reaction step is most assisted by the strong donor property of the carbene? Discuss.

8. (10 pts) If this coupling reaction worked with S=C=O and the diyne shown in Scheme 1, what would you expect the organic product (sketch out) to be based on what you should have learned in this course and why?

Organometallic Chemistry - 4571

ANSWER KEY

Homework # 1: Due: Feb 12, 2004 (2 PM)

Check the box to the right if you want your graded homework to be placed out in the public rack outside Prof. Stanley's office. Otherwise you will have to pick up your homework from Prof. Stanley in person:



1. (38 pts) Sketch out a structure showing the geometry about the metal center as accurately as possible and clearly show the electron counting for the complexes below. Phosphine ligand abbreviations are defined in your notes (phosphine ligand section). Molecules (some simplified) are from *Organometallics*, 2004, # 1 & 2, from the Chem Library or on-line at the Library E-Journal site (only from a campus computer). Note that I am using the author's formulas in some cases that use both the κ - and η -notations for ligand connectivity.

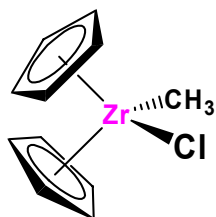
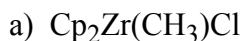

Zr(+4)	d0
2Cp ⁻	12e ⁻
CH ₃ ⁻	2e ⁻
Cl ⁻	2e ⁻
<hr/>	<hr/>
Total	16e ⁻

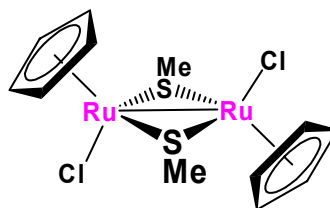
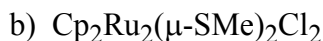

Ru(+3)	d5
Cp ⁻	6e ⁻
2 μ -SR ⁻	4e ⁻
Cl ⁻	2e ⁻
Ru-Ru	1e ⁻
<hr/>	<hr/>
Total	18e ⁻

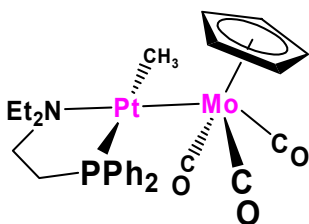

(heterobimetallic complex, count both metals)

Pt(+1)	d9	Mo(+1)	d5
P-N	4e ⁻	Cp ⁻	6e ⁻
CH ₃ ⁻	2e ⁻	3CO	6e ⁻
Pt-Mo	1e ⁻	Pt-Mo	1e ⁻
<hr/>	<hr/>	<hr/>	<hr/>
Total	16e ⁻	Total	18e ⁻

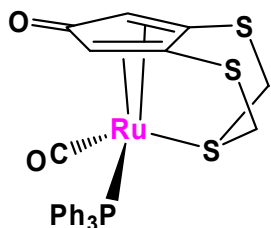
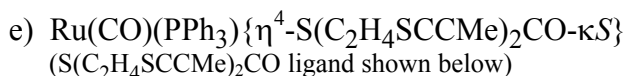

Ru(0)	d8
κ -SR ₂	2e ⁻
η^4 -C ₄ H ₂	4e ⁻
PPh ₃	2e ⁻
CO	2e ⁻
<hr/>	<hr/>
Total	18e ⁻

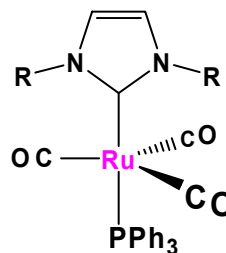
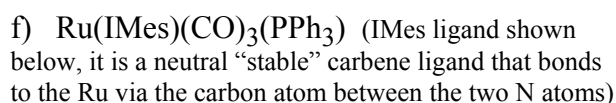

Ru(0)	d8
IMes	2e ⁻
PPh ₃	2e ⁻
3CO	6e ⁻
<hr/>	<hr/>
Total	18e ⁻

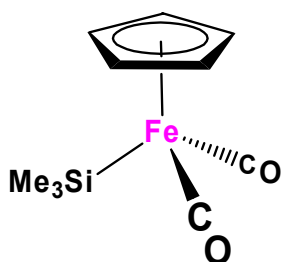

Fe(+2)	d6
Cp ⁻	6e ⁻
SiMe ₃ ⁻	2e ⁻
2CO	4e ⁻
<hr/>	<hr/>
Total	18e ⁻

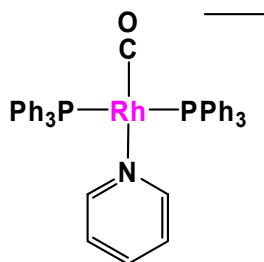

Rh(+1)	d8
py	2e ⁻
2PPh ₃	4e ⁻
CO	2e ⁻
<hr/>	<hr/>
Total	16e ⁻

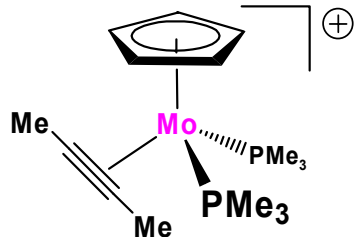
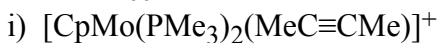

Mo(+2)	d4
Cp ⁻	6e-
2PMe ₃	4e-
alkyne	4e-
Total	18e-

The alkyne could also be considered a 2e- donor to give a 16e- complex

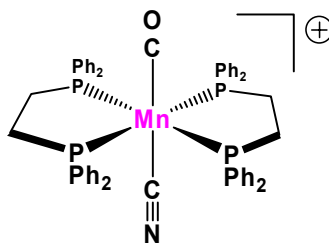

Mn(+2)	d5
2 dppe	8e-
CO	2e-
CN ⁻	2e-
Total	17e-

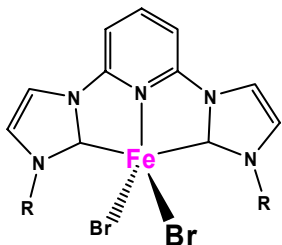
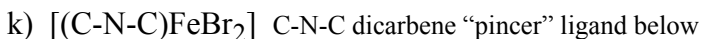

Fe(+2)	d6
C-N-C	6e-
2Br ⁻	4e-
Total	16e-

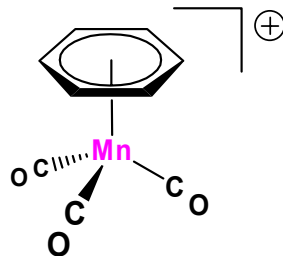
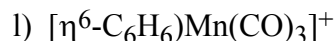

Mn(+1)	d6
C ₆ H ₆	6e-
3CO	6e-
Total	18e-

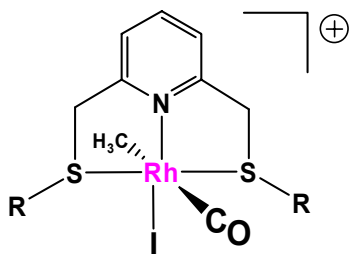
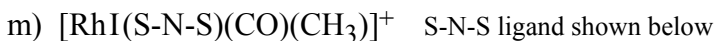

Rh(+3)	d6
S-N-S	6e-
CO	2e-
CH ₃ ⁻	2e-
I ⁻	2e-
Total	18e-

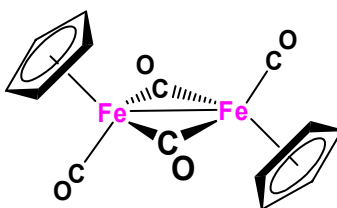
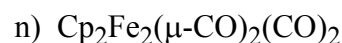

Fe(+1)	d7
Cp ⁻	6e-
CO	2e-
2μ-CO	2e-
Fe-Fe	1e-
Total	18e-

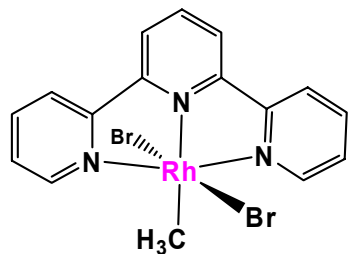
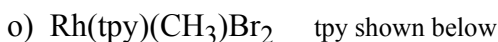

Rh(+3)	d6
tpy	6e-
CH ₃ ⁻	2e-
2Br ⁻	4e-
Total	18e-



py = pyridine; IMes = see problem f

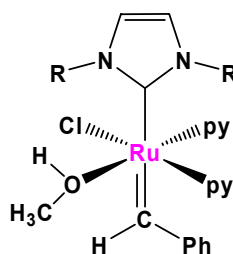

Ru(+3)	d5
IMes	2e-
2 py	4e-
MeOH	2e-
PhHC ²⁻	4e-
Cl ⁻	2e-
Total	19e-

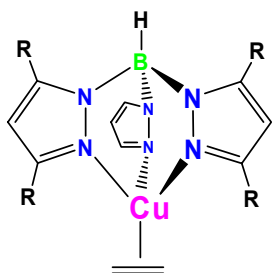
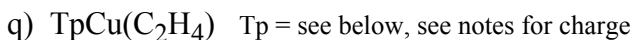

Cu(+1)	d10
Tp ⁻	6e-
ethylene	2e-
Total	18e-

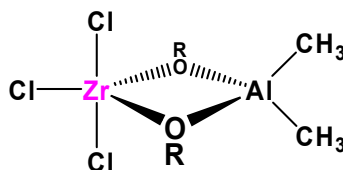
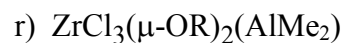

Zr(+4)	d0
3Cl ⁻	6e-
2 μ-OR ⁻	8e-
Total	14e-

There are a total of 7 anionic ligands. The Al is +3 and the Zr is +4 to balance it all out

Each OR- ligand has 3 lone pairs and can use two sets of these to donate to the very electron deficient Zr.

2. (12 pts) Propose an **18e- structure** for the following metal/ligand combinations. Use at least one of each metal and ligand listed. Complexes must be neutral. Don't use more than 2 metal centers. Clearly show your electron counting. Ligands are shown without charges, please indicate the proper ligand charge in your electron counting. Draw a reasonable structure showing the geometry about the metal center(s).

a) Ir, Cp, C≡NMe

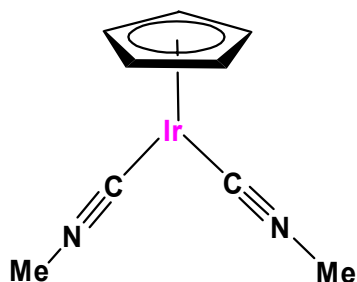

Ir(+1)	d8
Cp ⁻	6e-
2 CNR	4e-
<hr/>	
Total	18e-

b) Zr, NR₂, CR₂, PMe₃

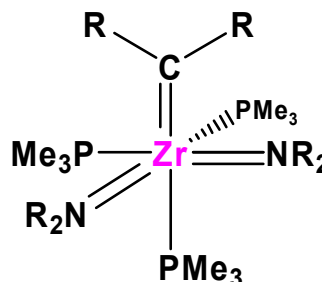

Zr(+4)	d0
CR ₂ ⁻	4e-
3PMe ₃	6e-
2NR ₂ ⁻	8e-
<hr/>	
Total	18e-

c) Mo, Cp, CH₃, N≡CMe

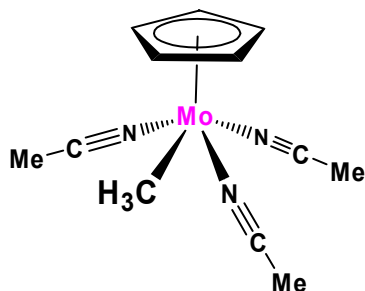

Mo(+2)	d4
Cp ⁻	6e-
CH ₃ ⁻	2e-
3N≡CR	6e-
<hr/>	
Total	18e-

d) Pt, dmpm (bridging), μ-CO (only one), CO

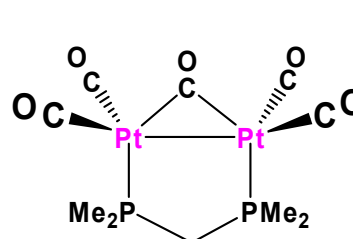

Pt(0)	d10
PR ₃	2e-
2CO	4e-
μ-CO	1e-
Pt-Pt	1e-
<hr/>	
Total	18e-

Organometallic Chemistry - 4571

ANSWER KEY

Homework # 1: Due: February 17, 2005

1. (38 pts) Sketch out a structure showing the geometry about the metal center as accurately as possible and clearly show the electron counting for the complexes below. Phosphine ligand abbreviations are defined in your notes (see the phosphine ligand section). All the molecules (some simplified) are from *Organometallics*, **1999**, 18 (#24), which you can find in the Chemistry Library or on-line at the Library E-Journal site (only accessible from a campus computer).

See page Lewis 5 in your notes

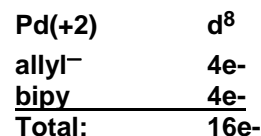
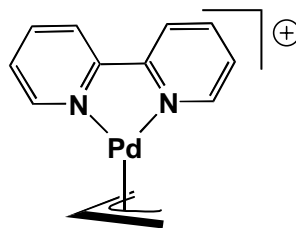
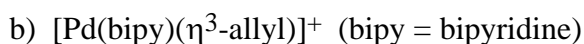
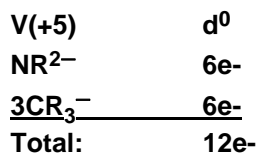
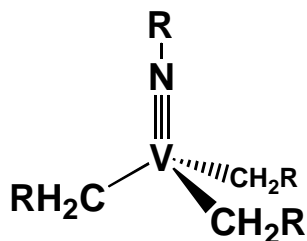

This will have square planar geometry around the Pd

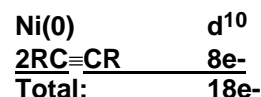
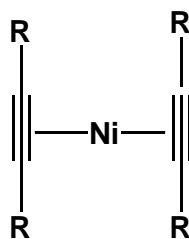
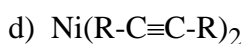
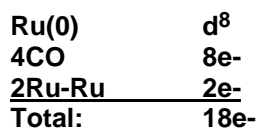
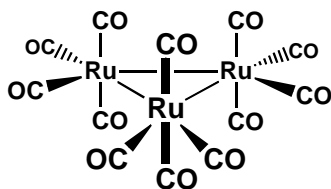
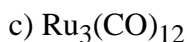

This will have tetrahedral geometry around the Ni

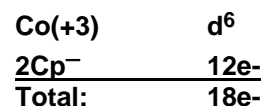
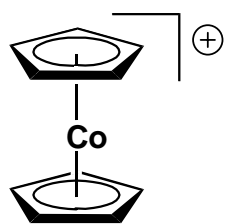
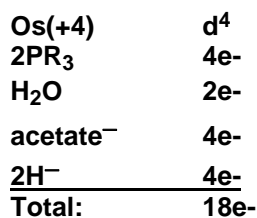
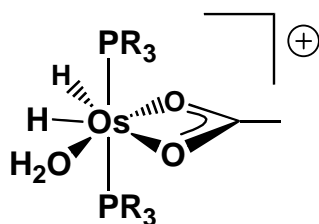
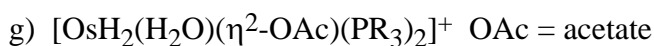
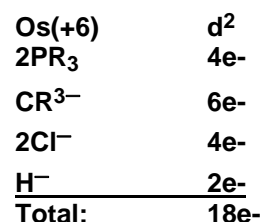
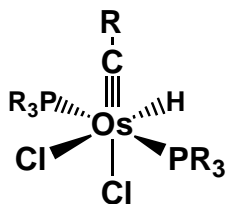
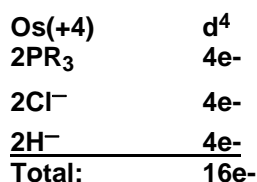
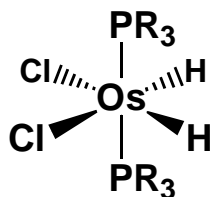

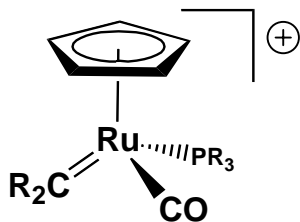

Ru(+4)	d^4
PR_3	2e-
Cp^-	6e-
CR_2^{2-}	4e-
CO	2e-
Total:	18e-

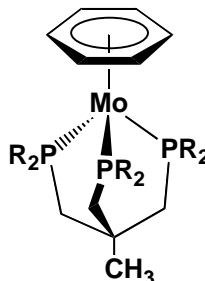
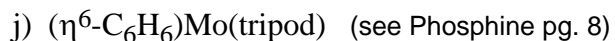

Mo(0)	d^6
3PR_3	6e-
$\eta^6\text{-C}_6\text{H}_6$	6e-
Total:	18e-

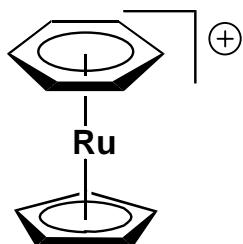
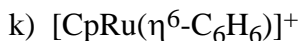

Ru(+2)	d^6
Cp^-	6e-
$\eta^6\text{-C}_6\text{H}_6$	6e-
Total:	18e-

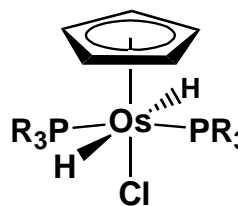
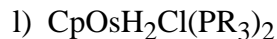

Os(+4)	d^4
2PR_3	4e-
Cp^-	6e-
2H^-	4e-
Cl^-	2e-
Total:	20e-

the real compound has one less ligand

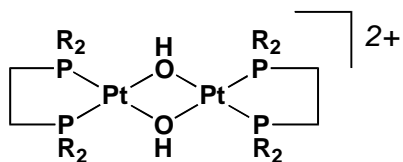

Pt(+2)	d^8
2PR_3	4e-
$2\mu\text{-OH}^-$	4e-
Total:	16e-

Pt(+2) d^8 is happy with a 16e- configuration - no need to put in a Pt=Pt bond

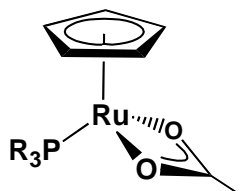
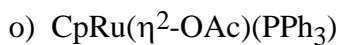

Ru(+2)	d^6
Cp^-	6e-
PR_3	2e-
acetate $^-$	4e-
Total:	18e-

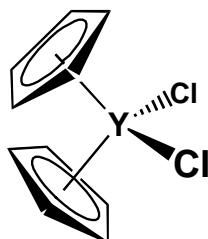
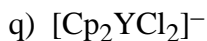

Y(+3)	d^0
2Cp^-	12e-
2Cl^-	4e-
Total:	16e-

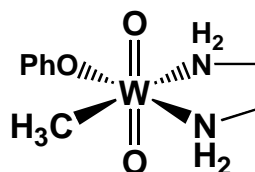
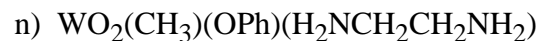

W(+6)	d^0
2NR_3	4e-
OPh^-	4e-
CH_3^-	2e-
2O^{2-}	8e-
Total:	18e-

you could also count this as a 16e- complex with the OPh^- donating just 2e-

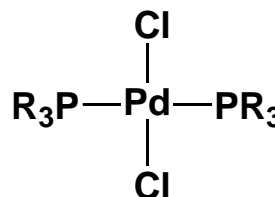

Pd(+2)	d^8
2PR_3	4e-
Cl^-	4e-
Total:	16e-

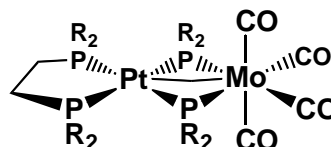

Pt(+1)	d^9
$2\mu\text{-PR}_2^-$	4e-
2PR_3	4e-
Pt-Mo	1e-
Total:	18e-

Mo(+1)	d^5
$2\mu\text{-PR}_2^-$	4e-
4CO	8e-
Pt-Mo	1e-
Total:	18e-

This could also be counted with Pt(+2) and Mo(0) centers giving 16- and 18e- centers and no Pt-Mo bond.

2. (12 pts) Propose an **18e- structure** for the following metal/ligand combinations. Use at least one of each metal and ligand listed. Complexes should be neutral. Don't use more than 2 metal centers. Show your electron counting. Ligands are shown without charges, please indicate the proper ligand charge in your electron counting. Draw a reasonable structure showing the geometry about the metal center(s).

a) Ta, NMe, NMe₂, N≡CCH₃

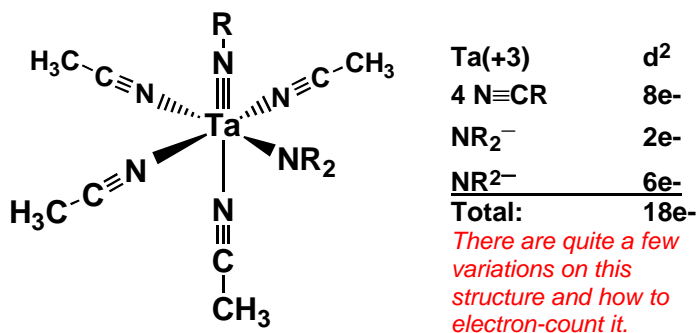

b) Re, CO, PMe₂ (bimetallic complex)

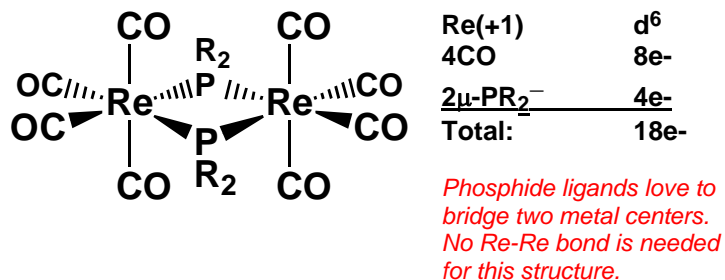

c) Os, allyl, O

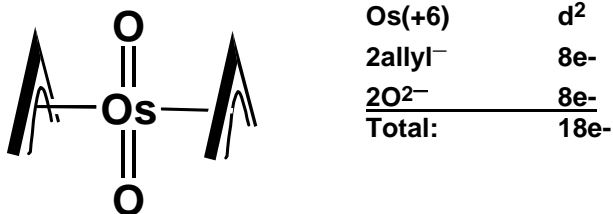

d) Mn, CO (no bridging CO's)

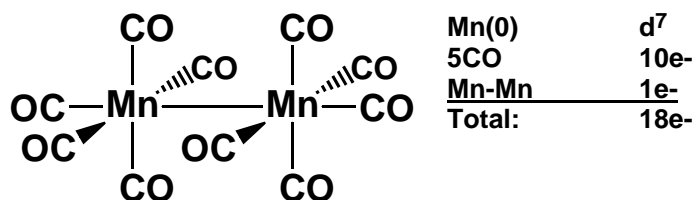

HW # 2 Due: March 25 (by 2 PM!), 2004

Check the box to the right if you want your graded homework to be placed out in the public rack outside Prof. Stanley's office. Otherwise you will have to pick up your homework from Prof. Stanley in person:

1. (18 pts) For each of the following pairs of metal complexes, circle the one that should have the lowest average carbonyl IR stretching frequency. What does this tell you about the relative electron density on the metal center (electron-rich or deficient)? Briefly discuss your reasoning for each case.



Lowest average CO stretching frequency means the metal center with the highest electron-density available for π -backbonding.

On page 5 of the carbonyl chapter we discussed how $[\text{Ag}(\text{CO})]^+$ had no π -backbonding due to the cationic charge and relatively high electronegativity of the Ag atom (especially in its cationic state). The high electronegativity of the F^- anion means that it will donate very little electron density to the Ag^+ center, meaning that one essentially has a $[\text{Ag}(\text{CO})]^+$ -like system with no little or no π -backbonding. The Mn complex, on the other hand, has two strong donating alkylated phosphine ligands that will increase the electron-density on the Mn center and help compensate to some extent for the cationic charge.

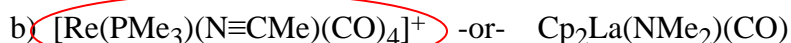

The La complex is d^0 and can't π -backbond to any real extent.



Cp^* and Br^- are stronger donating ligands and these override the higher electronegativity of the Fe atom vs. Os atom. This makes the Fe center more electron-rich with more π -backbonding to the carbonyls. Ligand donor effects are usually more important than electronegativity differences between metal atoms.

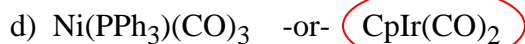

Cp^- is a stronger donating ligand relative to PPh_3 , the Ir complex only has 2 CO ligands (so each can do more π -backbonding), and the Ir has lower electronegativity relative to Ni. All these will work together to make the Ir complex more electron-rich and have a lower average CO stretching frequency.

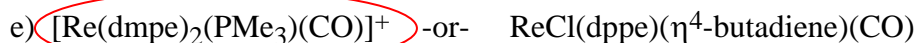

The two dmpe ($\text{Me}_2\text{PCH}_2\text{CH}_2\text{PMe}_2$) ligands and PMe_3 are all alkylated, strong donor phosphines that will more than compensate for the cationic charge to make the circled complex the most electron-rich. Dppe is only a moderate donor bisphosphine, butadiene is only a weak to moderate donor, and Cl^- is generally not a good donor ligand.

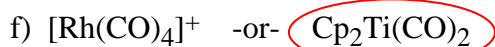

The Ti center is in the +2 oxidation state with a d^2 electron count. This makes it very electron-rich relative to the cationic d^8 , but considerably more electronegative Rh center that has 4 CO ligands.

Lowest pKa means the most acidic hydride which will have the most electron-deficient metal

2. (18 pts) For each of the following pairs of metal hydride complexes, circle the one that should have the **lowest** pK_a value. Briefly discuss your reasoning for each case.

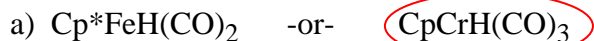

The Cr complex has 3 π -backbonding CO ligands and a "normal" Cp^- ligand, while the Fe complex has a considerably stronger donating Cp^{*-} and only 2 CO ligands. This will override the small electronegativity difference between the two metal centers and make the Cr center more electron deficient, which will make the hydride more acidic.

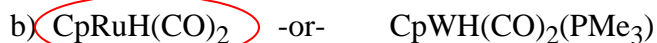

W has a strong donating PMe_3 ligand and is less electronegative relative to Ru. These will work together to make the Ru more electron-deficient and the one with the more acidic hydride.

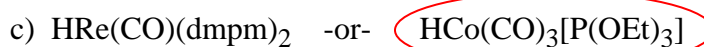

The phosphite ligand on the Co complex is not a very good donor, but is a moderate π -acceptor ligand. The Co complex also has 3 π -backbonding CO ligands and the Co is more electronegative relative to the Re center. The Re has 4 strongly donating alkylated phosphines and only one CO ligand.

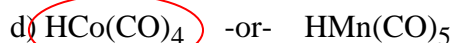

According to the table on page 2 of the hydride chapter, $\text{HMn}(\text{CO})_5$ has a pK_a of 15.1, while $\text{HCo}(\text{CO})_4$ has a pK_a of 8.4 (in acetonitrile). So the Co complex is 7 orders of magnitude more acidic. The main reason for this is the increased electronegativity of the Co center relative to Mn, which more than compensates for the presence of one less CO ligand.



The poor donor, but moderate π -acceptor phosphite ligands on the electronegative Ni complex, coupled with the cationic charge will work together to make this hydride the most acidic. The Nb complex is d^0 , but that is not much of a factor in determining hydride acidities.

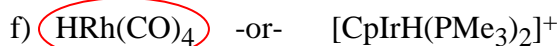

The strong donor Cp^- and phosphine ligands on the Ir complex will more than compensate for the cationic charge, making the Ir center more electron rich. The Rh complex has 4 strong π -acceptor ligands that can help stabilize the negative charge on the dissociation of an H^+ from that complex.

3. (8 points) Compare the methyl isocyanide ($\text{C}\equiv\text{NCH}_3$) ligand to $\text{C}\equiv\text{O}$ (carbonyl) with regards to its σ donor ability and π -backbonding ability. Discuss. Clearly explain the origin of any differences in metal-ligand bonding between the two ligands.

$\text{C}\equiv\text{NCH}_3$ and $\text{C}\equiv\text{O}$ are isoelectronic, which means that they have the same basic electronic structure. Both have relatively high energy lone pairs on the carbon and use these to σ -bond to the metal center. Both have triple bonds to the carbon and two sets of relatively low lying π^* -antibonding orbitals that are used to π -backbond to the metal center. The difference is that the O atom in CO is more electronegative and this lowers the energy of the carbon lone pair making it a poorer σ -donor. The electronegative O atom also lowers the energy of the empty π^* -antibonding orbitals making them better π -acceptors. The less electronegative N atom in isocyanide coupled with the donor methyl group on that nitrogen, increases the electron density of the carbon lone pair, making it a better σ -donor, while the π^* -antibonding orbitals are pushed up in energy making them poorer π -acceptors. So isocyanide is a better σ -donor and weaker π -acceptor relative to CO.

4. (6 points) Circle the correct ordering of the following group of carbenes (or alkylidene) from the strongest $\text{M}=\text{CR}_2$ bond to weakest. Clearly explain your reasoning.

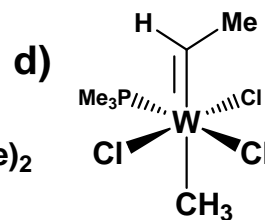
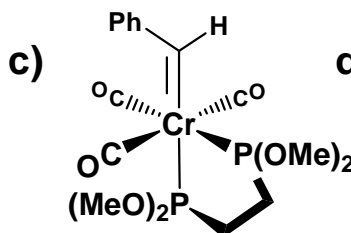
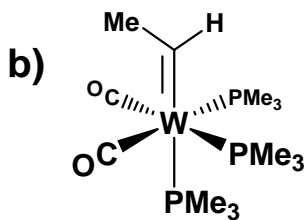
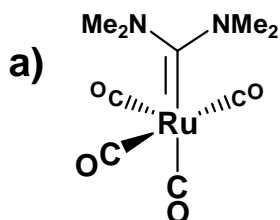

d > b > c > a

b > c > d > a

d > c > b > a

c > a > d > b

Complex **d**) is a Schrock alkylidene ($\text{W}(+6) d^0$ if one counts the alkylidene as dianionic) and has the strongest $\text{W}=\text{CR}_2$ bond. The other 3 complexes are Fischer carbenes (d^6 and d^8 configurations if one counts the carbene as neutral) and are ordered from most electron-rich metal center and least π -donating donor groups on the carbene to least electron-rich metal with the most p -donating donor groups on the carbene. **B**) is the most electron-rich metal with 3 strong donating alkylated phosphine ligands and only 2 π -acceptor CO's. The carbene ligand on **b**) does not have any π -donating groups, which will increase the amount of metal-to-carbene p -backbonding (stronger $\text{M}=\text{CR}_2$ bond). **C**) is the next most electron-rich complex with 3 electron-withdrawing CO ligands and two weakly donating (moderate p -acceptor) phosphite ligands. The Ph group on the carbene is moderately π -donating. **A**) has two strongly π -donating NMe_2 groups on the carbene that will pretty much block any π -backbonding from the Ru to the carbene. The Ru also has 4 good π -acceptor carbonyl ligands that will reduce its desire to π -backbond to the carbene.

Organometallic Chemistry - 4571
HW # 2 Due: March 17 (by 1PM!), 2005

ANSWER KEY

1. (20 pts) For each of the following pairs of metal complexes, circle the one that will have the highest CO stretching frequency. Briefly discuss your reasoning for each case.

The metal complex that has the least amount of electron density on the metal center (most electron deficient) will be the one with the highest IR CO stretching frequency.

a) $\text{TiO}_2(\text{PMe}_3)_2(\text{CO})_2$ or $\text{Cp}_2\text{Ti}(\text{CO})_2$

Although both complexes can be counted as 18 e- systems, the first Ti complex is d^0 and has no d electrons to π -backbond to the CO ligand. It is, therefore, the most electron deficient and will have the highest IR CO stretching frequency (and the most labile CO ligand). The second Ti complex is in the +2 oxidation state and has a rather electron-rich d^2 configuration.

b) $\text{RhH}(\text{CO})(\text{PPh}_3)_2$ or $\text{IrCl}(\text{CO})[\text{P}(\text{OMe})_3]_2$

The Ir complex is more electron-deficient due to the poorly donating Cl^- and $\text{P}(\text{OMe})_3$ ligands. The $\text{P}(\text{OMe})_3$ ligands are also moderately good π -backbonders. The Ir complex, therefore will have the higher CO stretching frequency. The Rh complex, on the other hand, has a strongly donating hydride and better donating PPh_3 ligands. The Ir is less electronegative than Rh and as a 3rd row metal will bind more strongly to the CO, but these are relatively minor factors compared to the more dominate ligand effects.

c) $\text{PtCl}_2(\text{CO})_2$ or $\text{Ni}(\text{CO})_2(\text{PPh}_3)_2$

The Pt complex is more electron-deficient due to the poorly donating Cl^- ligands, the +2 oxidation state, and d^8 electron configuration. The Ni complex is in the zero oxidation state (d^{10}) and has moderately good donor PPh_3 ligands. Pt is less electronegative than Ni and as a 3rd row metal will bind more strongly to the CO, but these are relatively minor factors compared to the stronger ligand effects.

d) $[\text{Co}(\text{CO})_4]^-$ or $[\text{Fe}(\text{CO})_4]^{2-}$

The Co complex is less electron-rich due to the fact that it is more electronegative, and thus willing to hang onto its d electron density and not π -backbond to the CO ligands. Secondly it only has a single anionic charge while the Fe complex is dianionic. This will overload the Fe complex and make it considerably more electron-rich. The ν_{CO} stretching frequency for each complex is given in your notes.

e) $\text{MnF}(\text{CO})_5$ or $\text{Wl}_2(\text{CO})_4$

The Mn complex is less electron-rich due to the fact that it has a very poorly donating F^- ligand and one extra CO ligand relative to the W complex. Secondly, it is more electronegative and will hang onto its d electron density and not π -backbond to the CO ligands as well.

2. (20 pts) For each of the following pairs of metal hydride complexes, circle the one that should have the lowest pK_a value. Briefly discuss your reasoning for each case.

The metal complex that has the least amount of electron density on the metal center (most electron deficient) will be the one with the lowest pK_a value (most acidic).

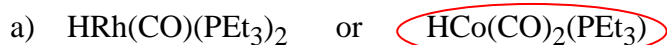

The Co complex is less electron-rich due to the fact that it has two electron-withdrawing CO ligands and only one strongly donating PEt_3 ligand. It is also more electronegative than the Rh center.



The Fe complex is less electron-rich due to the fact that it has four electron-withdrawing CO ligands. It is also more electronegative than the Os center. The bipy ligands on the Os are poor π -backbonding ligands.



The Ta complex is less electron-rich due to the fact that it has two very poorly donating F^- ligands. This will make the Ta center more cationic and likely to dissociate an H^+ .



The second Re complex is less electron-rich due to the fact that it has three electron-withdrawing CO ligands and two poorly donating $\text{P}(\text{OMe})_3$ ligands. The first Re complex has four strongly donating PEt_3 ligands and three very strongly donating hydrides. It is true that the second Re complex is d^6 , while the first one is d^4 , but the ligand donor properties dominate.

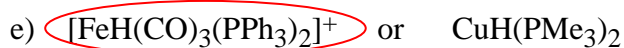

The Fe complex is more electron deficient due to the fact that it is cationic, has three electron-withdrawing CO ligands, and two moderately donating PPh_3 ligands. The Cu complex has two strongly donating phosphine ligands. Although the Cu is more electronegative, the cationic charge and ligand factors on the Fe complex dominate.

4. (10 pts) Aside from CO, what other ligands mentioned in the big ligand table (Intro 15-20) in your notes can act like π -backbonding (or π -acceptor) ligands and would have easily monitored IR stretching frequencies (in the $2800\text{-}1600\text{ cm}^{-1}$ region) that might prove useful as "sensors" for measuring the amount of electron density (or lack thereof) on a transition metal center? [*Hint*: there are 3 or 4 reasonable choices] Discuss which of these would be the best choice for this and why.

We are looking for ligands that have $\text{X}=\text{Y}$ or $\text{X}\equiv\text{Y}$ ($\text{X}, \text{Y} = \text{C}, \text{N}, \text{O}$) with double or triple bonding between the two atoms. Only these will have characteristic IR stretching frequencies in the range indicated. The best, of course, is $\text{N}=\text{O}^+$, followed by $\text{C}\equiv\text{N}-\text{R}$ (isocyanide), $\text{R}-\text{C}\equiv\text{C}-\text{R}$ (alkynes), and $\text{R}_2\text{C}=\text{CR}_2$ (alkenes). Nitriles ($\text{N}\equiv\text{C}-\text{R}$) are another possibility, but it was mentioned in the notes and lecture that these are not particularly good π -acceptors. Anionic ligands like $\text{C}\equiv\text{N}^-$, $\text{C}\equiv\text{C}-\text{R}^-$, and $\text{CH}=\text{CR}_2^-$ are not good π -acceptors due to their anionic charges.

HW # 3 Due: April 15 (by 2 PM), 2004

Check the box to the right if you want your graded homework to be placed out in the public rack outside Prof. Stanley's office. Otherwise you will have to pick up your homework from Prof. Stanley in person:

1. (30 pts) Identify the following reactions by their type (migratory insertion, elimination, oxidative addition, reductive elimination, substitution, ligand addition, β -hydride elimination, ligand coordination change, etc.). Note that in some cases one will have to use more than one description for a reaction which may have several steps and the order may be important. No discussion is necessary.

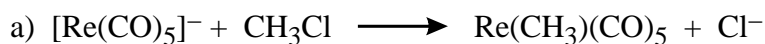

oxidative addition

(CH_3Cl is an electrophilic reactant and does not need an empty orbital to pre-coordinate to)

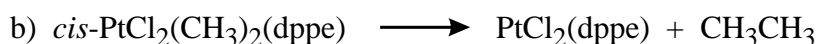

reductive elimination

-or-

Cl⁻ ligand dissociation
reductive elimination
Cl⁻ ligand addition

Loss of a Cl⁻ will make the unsaturated cationic Pt complex more likely to do the reductive elimination

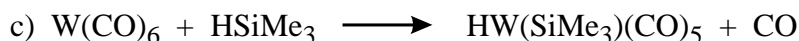

1) ligand dissociation
2) oxidative addition

The order here is important as HSiR_3 is a non-electrophilic reactant that needs an empty coordination site to pre-coordinate prior to oxidative addition. $\text{W}(\text{CO})_6$ is a saturated 18e⁻ complex.

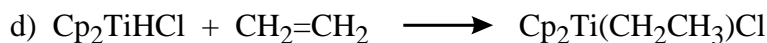

1) ligand addition of ethylene

2) migratory insertion (of hydride and coordinated ethylene)

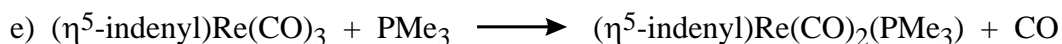

1) indenyl η^5 - to η^3 -coordination (hapticity) change (to open up free coordination site)

2) ligand addition of PMe_3

3) ligand dissociation of CO

4) indenyl η^3 - to η^5 -coordination (hapticity) change

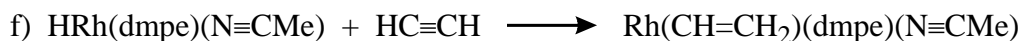

1) ligand addition (of acetylene)

2) migratory insertion (of hydride and coordinated acetylene)

2. (30 pts) For each pair of complexes shown below, circle the one that should be the most reactive towards the oxidative addition of the reactant indicated. Give a brief explanation for your choice.

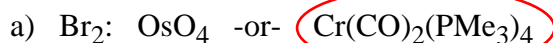

The Os is Os(+8) and d^0 – can't do an oxidative addition.

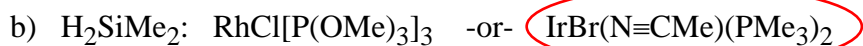

Both complexes are 16e- and have an available empty orbital that the silane can precoordinate to (required for this non-electrophilic substrate). The Ir complex is more electron-rich with strong donor PMe_3 ligands and the less electronegative Br^- that will also donate more e- density to the metal center. Ir is also less electronegative than Rh and can do an oxidative addition more readily.



The Pt complex is more electron-rich due to the strong donor alkylated dmpe chelating bisphosphine ligand. It is somewhat more electronegative than the Ir center, but is neutral and in a considerably lower oxidation state (+2) vs. the cationic Ir center (+4) that has poor donating CF_3^- and PPh_3 ligands.

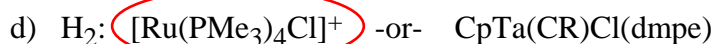

The Ta complex is Ta(+5) oxidation state, which is d^0 , so it can NOT do an oxidative addition (it could potentially do hydrogenolysis, but that isn't what I'm asking).

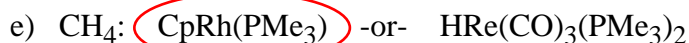

CH_4 is a very non-electrophilic reagent that definitely needs an empty orbital and an electron-rich metal center to pre-coordinate to. The Rh complex is a reactive 16e- complex that has good donor ligands. This was one of the earliest transition metal complexes used to demonstrate oxidative addition of CH_4 to a metal center.

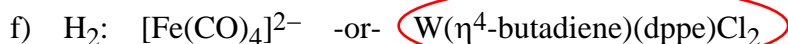

The W complex is 16e- d^4 and has the required empty orbital to pre-coordinate H_2 to initiate the oxidative addition. The Fe complex, although quite electron-rich, is 18e- and unlikely to dissociate one of the very strongly π -backbonding CO ligands to open up a free coordination site.

3. (20 pts) Olefin metathesis involves the following steps that I've labeled using one method of electron counting. The dashed vertical line through the metallocyclobutane ring illustrates which way that ring is breaking for the following step.

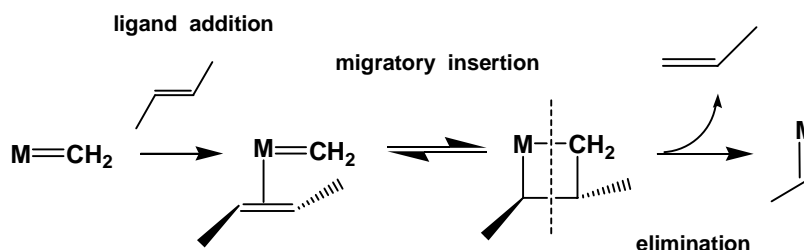

- a) (10 pts) Which way am I electron counting the $M=CR_2$ unit – as a neutral carbene or dianionic alkylidene? Briefly and clearly explain.

The migratory insertion and elimination steps above refer to a dianionic alkylidene formalism. Counting the alkylidene as dianionic, the initial metal oxidation state is +2. After the migratory insertion of the alkene with the alkylidene, the metallocyclobutane ring is essentially a dianionic dialkyl ligand and the metal center is still formally in the +2 oxidation state, as it is after the elimination of the final metathesized alkene. The lack of change of oxidation state is a feature of migratory insertion and elimination reactions.

- b) (10 pts) How would you label these three steps if one treated the $M=CR_2$ unit the other way from how I assigned it above? Briefly and clearly explain.

The first step, ligand addition, is the same for both. If you count the $M=CR_2$ group as a neutral carbene, then the reaction with the neutral alkene to produce a dianionic dialkyl (metallocyclobutane) changes the metal's oxidation state from 0 to +2, which is an oxidation. The formation of a new C-C bond between the two reactants is a coupling reaction, so we would label this an oxidative coupling reaction. The last step takes the +2 oxidation state metal and returns it to the 0 oxidation state and eliminates a neutral molecule, this is a reductive elimination reaction.

4. (20 pts) Consider the following catalytic cycle. Label each step in the boxes provided with the reaction step(s) that is (are) occurring. Some steps may have more than one fundamental reaction, if so list each one in the correct order if the order is important.

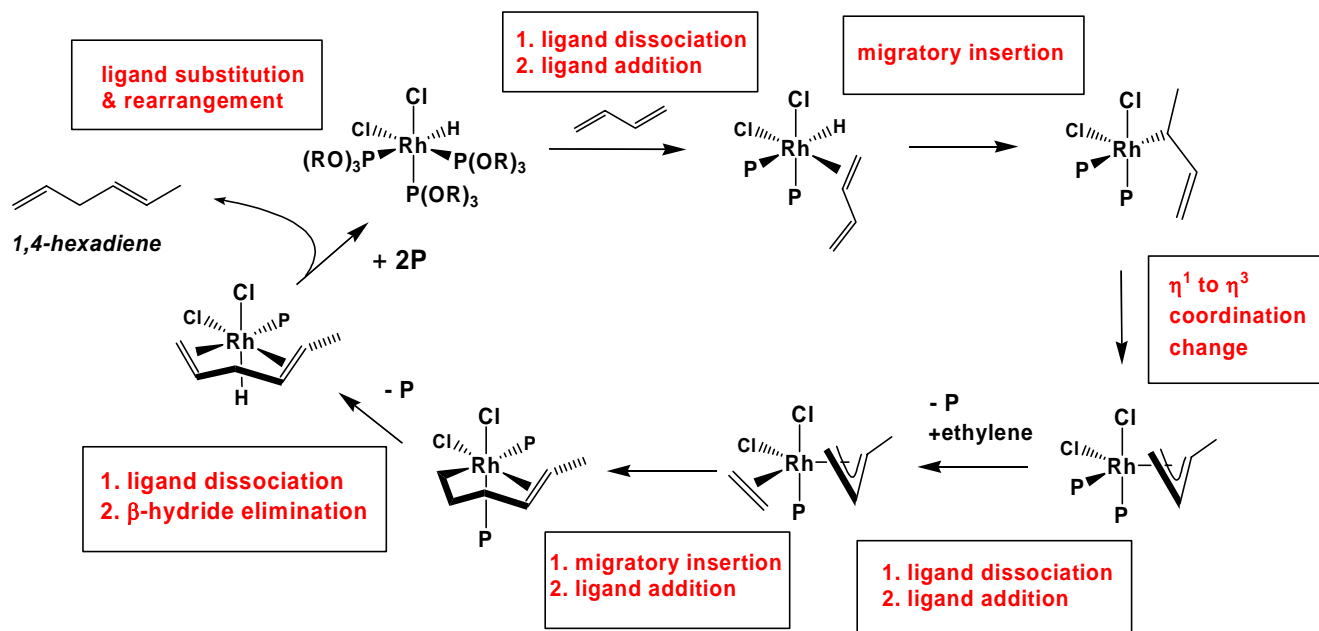

Homework # 3 (Due: April 15, 2005 by 10 AM)

1. (40 pts) Identify the following reactions by their type (migratory insertion, elimination, oxidative addition, reductive elimination, substitution, ligand addition, ligand dissociation, β -elimination, ligand coordination change, etc.). Note that one may have to use more than one description for a reaction that may have several steps. For reactions with several steps, if the order is important you must list the steps in the correct order.

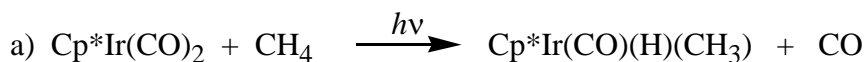

- 1) CO ligand dissociation (promoted by photolysis)
- 2) oxidative addition of methane C-H bond

Ir(+1) going to Ir(+3) indicates an oxidative addition rxn. CH₄ is a non-polar substrate and needs an empty orbital on the metal to bind to prior to oxidative addition.

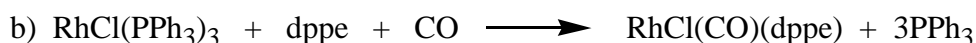

- 1) PPh₃ substitution with CO
- 2) two PPh₃ substitutions by dppe (one arm at a time)

The first PPh₃ substitution probably occurs via a dissociative route due to the steric bulk of the 3 PPh₃ groups. The incoming order of CO or dppe is not important.

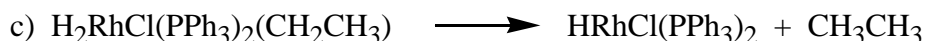

- 1) reductive elimination

Rh(+4) going to Rh(+2). One could also first have a ligand dissociation of PPh₃ or Cl- to help promote the reductive elimination rxn. But the dissociated ligand needs to re-coordinate after the reductive elimination.

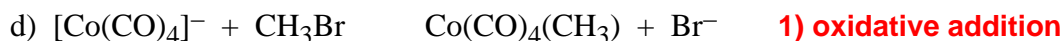

Co(-1) going to Co(+1) indicates an oxidative addition rxn. CH₃Br is an electrophilic reactive substrate that can react directly with an 18e- metal center via an S_N2 type attack of the metal on the CH₃-side of CH₃Br. This ejects the Br⁻ anion that does not coordinate to the metal since it is 18e- and does not need another ligand.



- 1) CO ligand dissociation
- 2) oxidative addition of H₂
- 3) reductive elimination of H⁻ and acyl⁻
- 4) CO ligand addition

This is a bit tricky because there appears to be no change in the oxidation state on the Mn. But the major rxn of H₂ with a d²⁻¹⁰ metal is via oxidative addition. You need an empty orbital to do this because H₂ is a non-electrophilic reagent, thus the initial CO ligand dissociation from the 18e- starting complex.



- 1) η^5 - to η^3 -hapticity (ligand coordination) change
- 2) CO ligand addition
- 3) PMe₃ ligand dissociation
- 4) η^3 - to η^5 -hapticity change

The indenyl ligand can readily change its hapticity from η^5 to η^3 . This opens up a free coordination site on the metal allowing ligand addition.

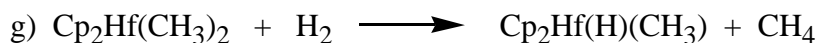

- 1) hydrogenolysis
- d⁰ metals can NOT do an oxidative addition rxn.*

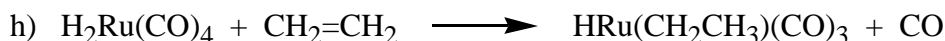

- 1) ligand dissociation
- 2) alkene ligand coordination
- 3) migratory insertion of hydride with alkene

The product is 16e- and would probably need to re-coordinate the dissociated CO (or another ligand) to get back to 18e-.

2. (20 pts) Consider the reaction shown below. Clearly describe what is happening. What kind of electronic effect R groups (electron-withdrawing or electron-donating) on the diene ligand will favor formation of the product? Why?

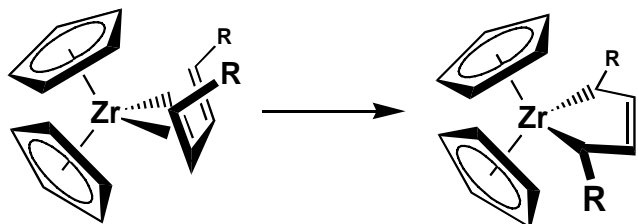

Oxidative Addition

$Zr(+2, d^2)$ is being oxidized to $Zr(+4, d^0)$. The diene ligand is accepting the two electrons from the Zr to become a dianionic ligand. Note that we have broken a bond in the diene (two double bonds down to one double bond).

Electron-withdrawing R-groups on the diene will **favor** the oxidative addition by helping the not very electronegative diene to attract the electrons from the metal. Normally one does want to have electron-donating ligands on the metal to help favor oxidative addition reactions and putting electron-donating groups on the Cp- rings will help make the metal more electron-rich and make the oxidative addition more facile.

b) Why won't the following complex undergo the same transformation?

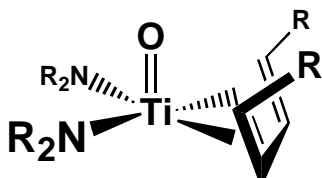

The Ti is in the +4 oxidation state and is already d^0 . A d^0 metal center can NOT do an oxidative addition reaction.

3. (20 pts) Consider the following reaction:



Show in detail each mechanistic step in the conversion to the product species shown. Label and clearly identify each step. The order of the steps may be important – if so list them in the correct order when necessary.

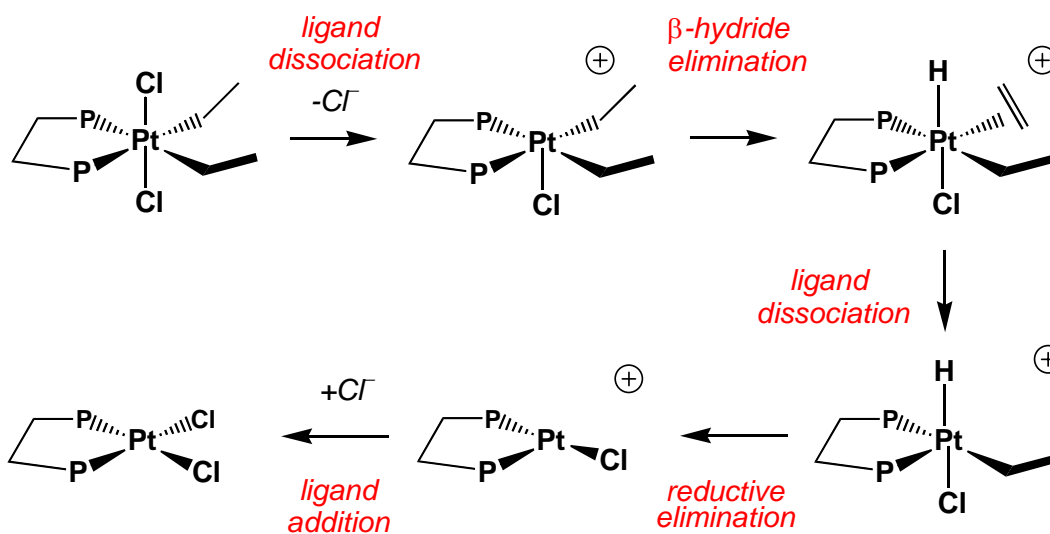

4. (10 pts) Label and clearly identify each step (i.e., migratory insertion, elimination, oxidative addition, reductive elimination, substitution, ligand addition, ligand dissociation, β -elimination, etc.) in the following catalytic reaction (called a Heck arene-alkene coupling reaction). Please write your answer(s) in the box next to the step. If there is more than one step occurring, please list them in the correct order if important.

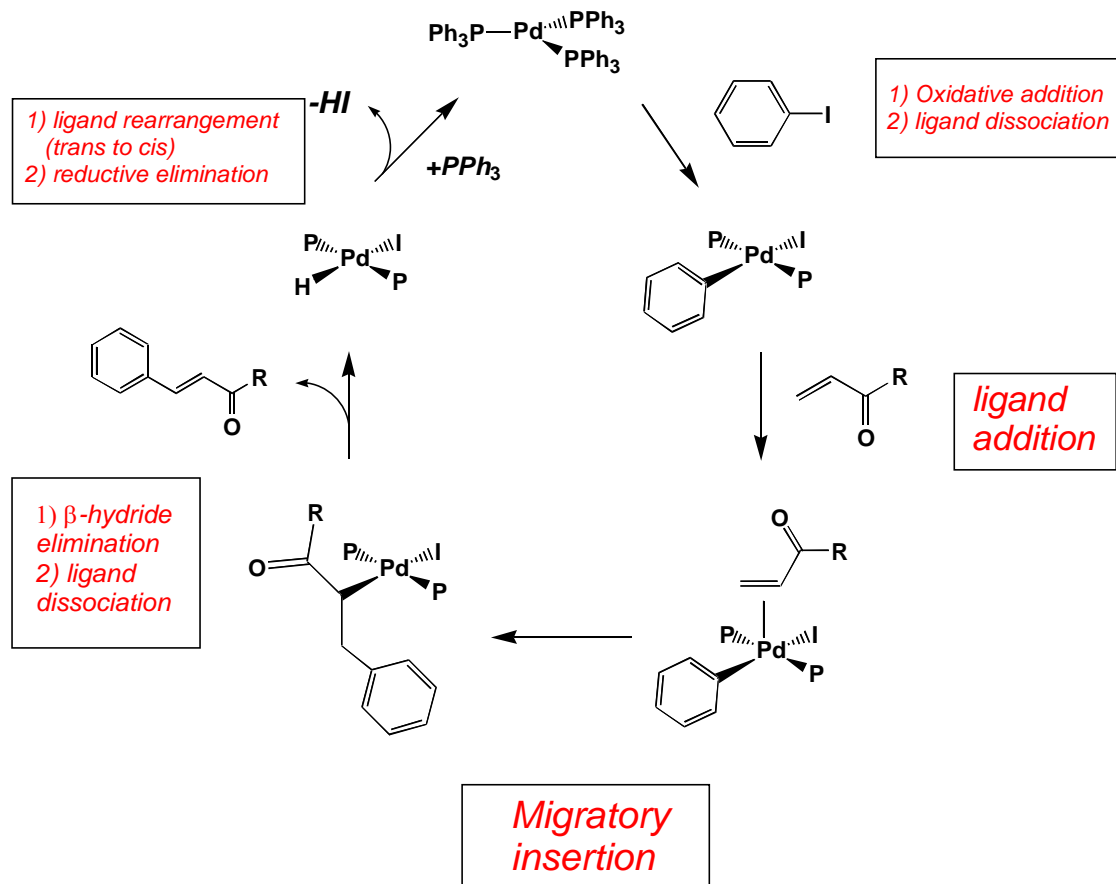

5. (10 pts) Which of the following products will be the most likely formed from the reaction shown. Circle the best choice and give a brief explanation/justification for your choice.



The starting Os complex is d^0 and can NOT do an oxidative addition reaction. So there is no reaction.

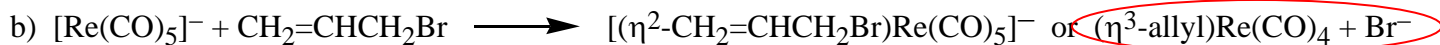

The 18e- Re complex is d^8 and can do a direct oxidative addition reaction with alkyl bromides, which are reactive polar substrates. No empty orbital is needed for this initial rxn. Once the oxidative addition occurs and forms the η^1 -allyl, one gets CO dissociation and a hapticity change from η^1 - to η^3 -allyl.

Homework # 4 -- Due: May 4, 2004 (by 2 PM)

Check the box to the right if you want your graded homework to be placed out in the public rack outside Prof. Stanley's office. Otherwise you will have to pick up your homework from Prof. Stanley in person:



1. (30 pts) The water-gas shift reaction is the following overall process:



a) (20 pts) Sketch out a catalytic cycle for the water-gas shift reaction that proceeds by the following steps using $\text{Fe}(\text{CO})_5$ as the starting catalyst: 1) nucleophilic attack of OH^- on one of the CO ligands, 2) CO_2 loss (decarboxylation), 3) protonation of Fe, 4) reductive elimination of H_2 , 5) CO ligand addition.

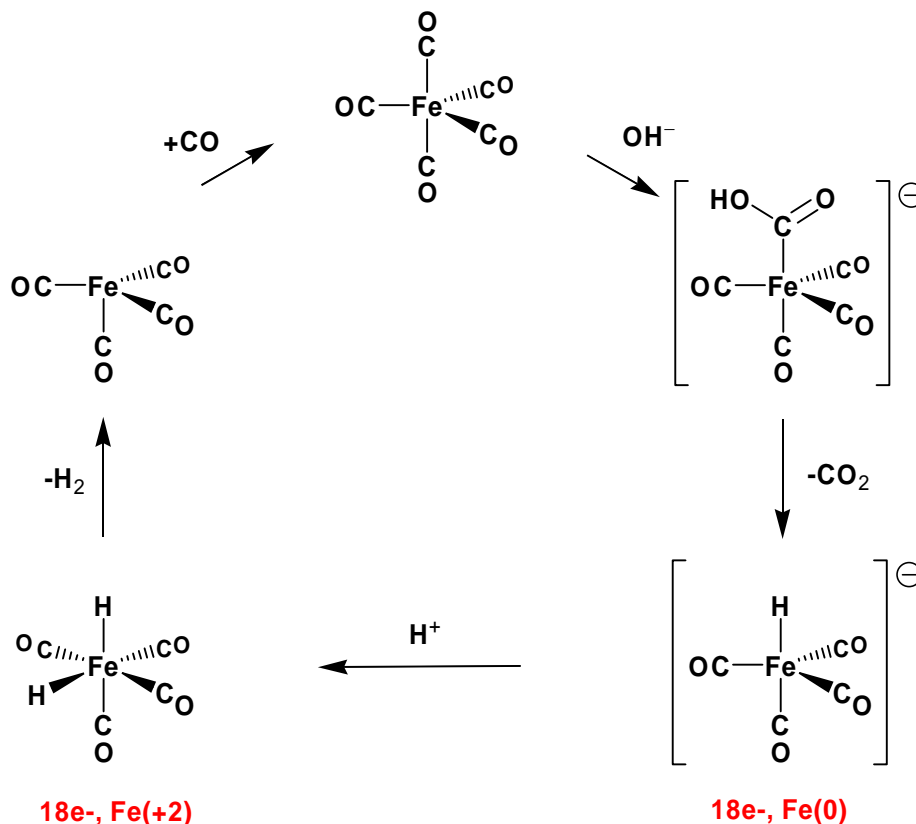

b) (5 pts) The loss of CO_2 from the Fe-carboxylic acid group to make the Fe-H complex isn't technically an elimination reaction as it occurs from an 18e- complex. What is the problem with dissociating a CO ligand first to make a 16e- complex, then doing a formal elimination and dissociation of CO_2 followed by ligand addition of CO to make the 18e- Fe-H complex.

The CO dissociation and β -hydride elimination process is shown below. The problem with it involves dissociating a π -backbonding CO ligand from an anionic metal center (formally Fe(0), d^8). This might not be that big a problem due to the other three π -backbonding CO's and the carboxylate group that is not a good donor.

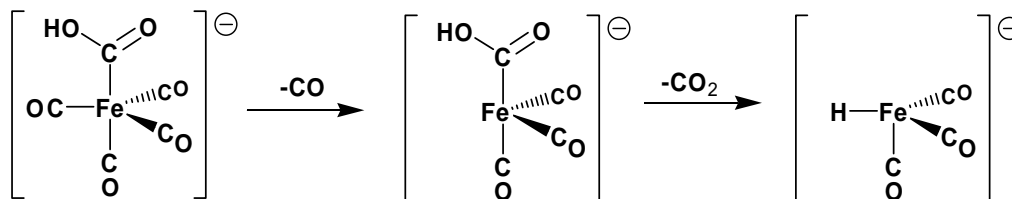

- c) (5 pts) The catalytic cycle described in part A) has a reductive elimination step, but no step formally labeled oxidative addition. What step is actually an oxidative addition and why?

The protonation step is formally an oxidative addition. Once the H⁺ is associated with a lone pair on the metal center, we electron count it as a hydride (H⁻) ligand. The original proton (H⁺) had no electrons, but now that it is coordinated to a metal center it is electron counted as a hydride (H⁻) that has 2 electrons and a negative charge. The electrons came from the metal center – see the oxidation state labeling for these species in the catalytic cycle on the previous page.

2. (20 pts) Sketch out and label a reasonable catalytic cycle for the following reaction called hydrovinylation:

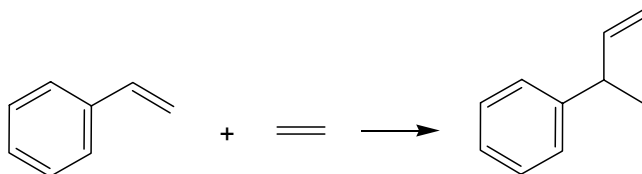

Start the cycle using the catalyst NiHCl(PCy₃) (shown below), clearly sketch out each complex with reasonably accurate structures, and clearly label each reaction step. The first step is styrene ligand addition.

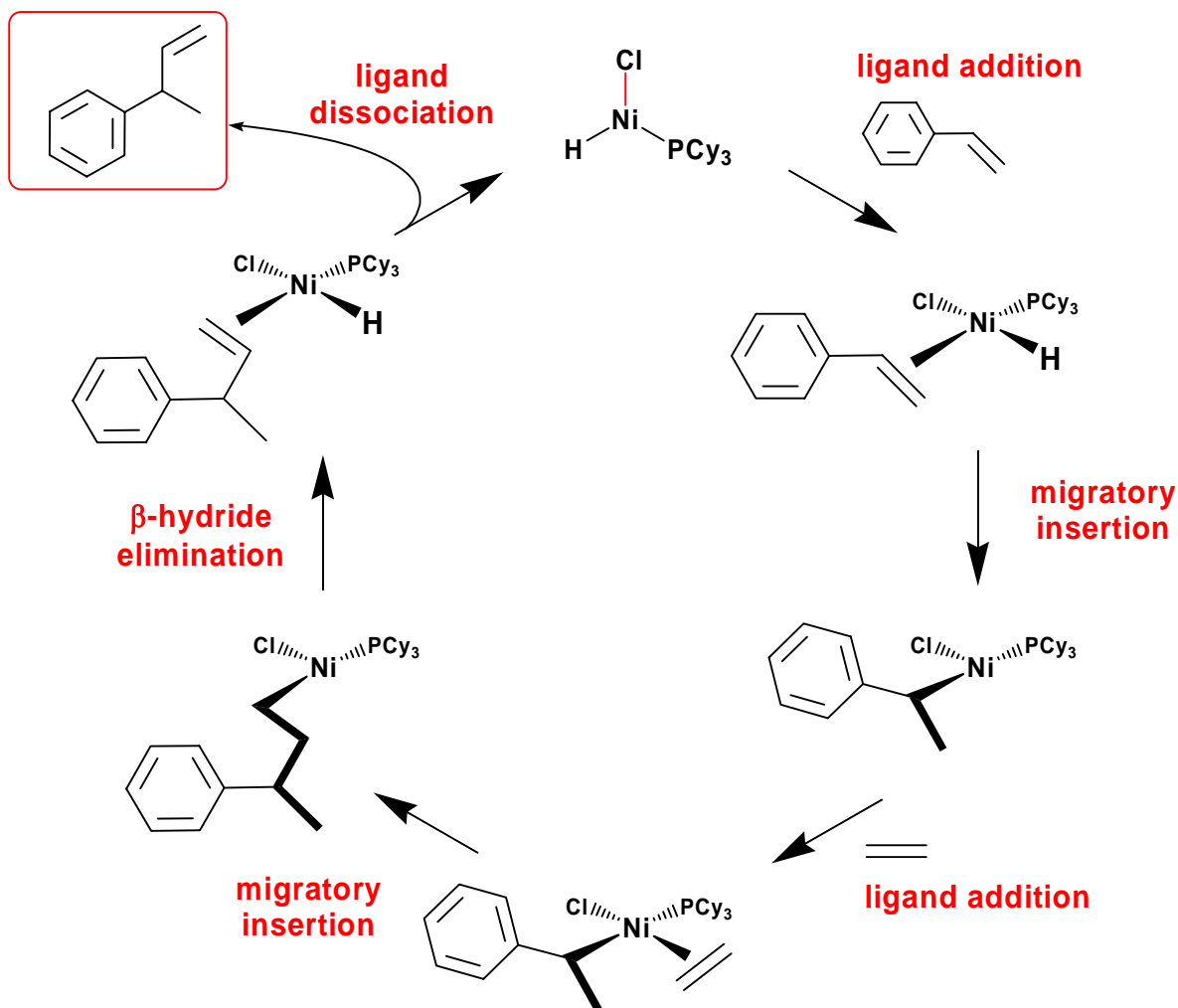

Read the attached *JACS* communication (*J. Am. Chem. Soc.*, 2004, 126, 4526-4527) and answer the following questions.

3. (5 pts) Sketch out the structure of the triflate anion (abbreviated OTf in the paper). Is this a strongly coordinating anion? Do you think it stays coordinated to the Au during catalysis? Discuss.

The triflate anion is shown to the right. It is a very poorly coordinating anion due to the delocalization of the negative charge over the 3 oxygen atoms and the electron-withdrawing CF_3 group (pulls the negative charges towards the fluorines). Given that the gold center is a very late transition metal and does not like oxygen-based ligands, it is probably not coordinated much to the Au center.

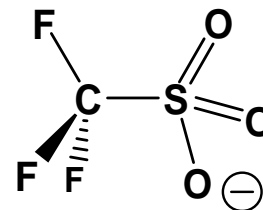

4. (15 pts) Consider the following table of catalytic data from the paper:

Table 1. Efficiency of Group XI Metal Catalysts in the Conia-Ene Reaction



entry	conditions	time	% conv. to 2 ^a
1	10 mol % AgOTf, DCE, rt	18 h	50
2	10 mol % AgOTf, 10 mol% PPh ₃ , DCE, rt	18 h	0
3	10 mol % AuCl ₃ , DCE, R.T.	30 min	30 ^b
4	10 mol % (PPh ₃)AuCl, DCE, 60 °C	6 h	0
5	10 mol % (PPh ₃)AuOTf, DCE, rt	<15 min	>95
6	10 mol % [(CyNC) ₂ Au]PF ₆ , DCE, rt	14 h	0
7	1 mol % [PPh ₃ Au] ₃ O]BF ₄ , DCE, 60 °C	1 h	0
8	1 mol % [PPh ₃ Au] ₃ O]BF ₄ , 5% HOTf, DCE, rt	<15 min	>95

^a As judged by ¹H NMR. ^b No starting material (1) remained.

- (a) (6 pts) What is the theoretical turnover number (TON) for experiment # 3 and # 8 in Table 1? Assuming that the % yield is the actual conversion to product (and not just the isolated yield) what is the actual turnover number for experiment # 3.

Mol % of catalyst refers to the fraction of catalyst relative to the limiting reactant used. TON is then 100% (total reactant) divided by the mol % of catalyst used.

The theoretical TON for exp # 3 is 10, for exp # 8 it is 100.

The actual TON for exp # 3 based on the % conversion to product 2 is just 3.

- (b) (4 pts) What is the average turnover frequency for experiment # 3? What is the average turnover frequency for experiment # 8 (assume 10 min reaction time and 95% conversion to product)?

TOF = TON(actual)/time

For exp # 3: 3 TO/0.5 hr = 6 TO/hr or 6 hr⁻¹ - or using minutes as the time unit: 0.1 TO/min

For exp # 8: 95 TO/0.167 hr = 569 TO/hr - or using minutes as the time unit: 9.5 TO/min

(c) (5 pts) What does footnote b mean since only 30% of product **2** was observed? (I'm looking for a short simple answer)

It means that there were side reactions (or one bad one) that consumed 70% of the reactant. This is bad. This could have been caused by the catalyst doing unwanted reactions (like polymerization) and the authors could not characterize what the side reaction product(s) was.

5. (10 pts) Based solely on what I have taught you this semester I would have favored mechanism A over B. Clearly discuss why.

Mechanism A is preferred due to the coordination of the alkyne to the Au center. The alkyne is clearly the best ligand for initial binding to the Au center. Gold is not very oxophilic and Mechanism B involves Au-O bonding to a greater extent. In the hydrogenation catalysis chapter, for example, there was the example of how Wilkinson's catalyst will completely hydrogenate an alkyne in the presence of an alkene. This is one example of the considerably higher kinetic activity of an alkyne. In Mechanism A once the cationic gold coordinates to the alkyne, it activates it for nucleophilic attack by the C=C double bond of the enol, which is not very electron-rich and would not do the ring closing readily without the involvement of the Au (or other Lewis acid-like metal).

6. (10 pts) For the optimized catalyst system used in Table 2 (footnote a), they add 1 mol % of AgOTf. What does this do? Why is the localized cationic charge on the Au generally important for the catalysis?

The AgOTf is added to abstract the chloride off the Au and precipitate it out as AgCl(s), which is almost completely insoluble in the solvents being used for the catalysis. The chloride coordinates too strongly to the Au making it neutral and less electrophilic (or electron withdrawing). By replacing the Cl⁻ with the far more weakly coordinating OTf⁻ anion, the Au is in the more reactive cationic form most of the time. The cationic charge of the Au is important to help it bind to the alkyne more strongly and activate it for the ring closing step.

7. (10 pts) In footnote 13 the authors discuss some of the solvent effects on the catalysis. What does the failure of the catalysis to work in coordinating solvents tell you about the strength of the substrate coordination to the catalyst? Do you think that DMSO would be a good solvent for the catalysis? Briefly and clearly discuss.

The failure of the catalysis to work in coordinating solvents either means that the solvent competes effectively for coordinating to the Au relative to the reactant, or that it coordinates along with the reactant and either sterically blocks the ring closing step or electronically deactivates catalyst-reactant complex by donating too much electron density that reduces the electrophilicity of the Au center. Although the solvent coordinates more weakly than the alkyne part of the reactant, the solvent is present in much higher concentration.

DMSO (shown to the right) should be a poor solvent for this reaction because it is a good coordinating solvent. The presence of lone pairs on the oxygen and sulfur means that it can coordinate via either atom depending on whether the metal prefers hard or soft donor groups. For Au, the DMSO will coordinate via the lone pair on the sulfur atom.

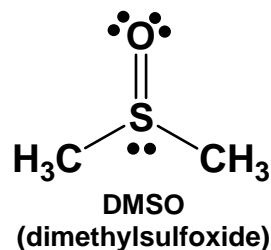

Homework # 4 -- Due: May 3, 2005 (by 2 PM)

Check the box to the right if you want your graded homework to be placed out in the public rack outside Prof. Stanley's office. Otherwise you will have to pick up your homework from Prof. Stanley in person:

Read the attached communication from the *Journal of the American Chemical Society* (Louie *et al*, *JACS*, 2002, 124, pg. 15188) and answer the following questions.

1. (10 pts) a) (5 pts) How many theoretical turnovers could the authors do using the information presented in Table 1? Briefly explain.

20 turnovers. The footnote states that there is 5 mole % Ni(COD)₂ and 10 mole % IPr ligand. It is common to add excess ligand, so one should usually base any turnover calculations on the amount of metal complex present. 5 mole % catalyst is with respect to the amount of reactant being used. So if we have 1 equivalent of reactant, there is 0.05 equivalents of catalyst present: $1/0.05 = 20$ turnovers maximum.

- b) (5 pts) What was the maximum number of turnovers they actually performed based on the discussion in the paper (information on first page)? Briefly explain.

100 turnovers. In the text they make two important statements. Page 1, bottom of first column: "Ultimately, quantitative yields (as determined using gas chromatography) were obtained using 5 mol % of Ni(COD)₂ . . ." and page 1, second column near bottom: "[catalyst] loadings could be decreased to 1 mol %, although higher substrate concentrations (> 0.75 M) were necessary to achieve high conversions." Both of these statements can be linked together to make the good assumption that the authors were able to get 100 turnovers (or very close to that).

2. (10 pts) Is there any important catalytic data missing from Table 1 or the main text of the paper? If there is important missing information, please state what is missing. If none is missing, just say none.

None.

They report all important info: temp, pressure (first column scheme), catalyst and ligand amounts, substrate concentration, solvent, time (from which average TOF can be calculated), and isolated yields. Selectivities are discussed in the text.

3. (10 pts) In Scheme 1 the authors have Ni(L)_n indicated as the catalyst, where L = the IPr carbene. What is the likely value of n (1 or 2?) and why?

n = 1. IPr is a VERY bulky ligand and in analogy with our discussion of Wilkinson's catalyst one has to dissociate one IPr ligand in order to generate the active catalyst. See the space-filling models of Ni(IPr)₂ that I posted on the web site and showed in class. Two IPr ligands pretty much fully encompass the Ni center leaving essentially no room for any other ligands to coordinate.

4. (10 pts) Prof. Louie refers to the reaction of CO_2 and one of the alkyne groups as a 2 + 2 cycloaddition. From an organic viewpoint this is correct. But from an organometallic mechanism viewpoint, what should this reaction be called and why? See the product of this reaction in Scheme 1 labeled **19**.

Oxidative coupling. The starting catalyst ($n = 1$ or 2) is $\text{Ni}(0)$, while complex **19** is $\text{Ni}(+2)$ with anionic alkoxide and vinyl ligands. This clearly indicates an *oxidative addition* reaction. The new C-C bond between the CO_2 and alkyne points to the more specific oxidative coupling reaction.

5. (20 points) The formation of complex **21** in Scheme 1 is not observed using the catalyst with IPr ligand. She does, however, see it when she uses a smaller carbene ligand.

- a) (5 pts) When complex **21** forms using a smaller carbene ligand it does not do a reductive elimination to kick off the organic product. Why not? Draw a structure of the organic product.

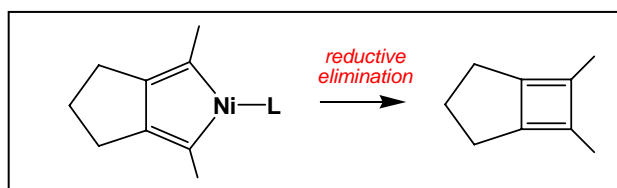

The formation of a cyclobutadiene ring is very high energy and unfavorable due to its anti-aromatic electronic properties and high ring strain (especially coupled with a 5-membered ring system). See page 5 of the alkene chapter.

- b) (15 pts) Complex **21** (with a smaller carbene ligand) will, however, readily react with acetylene ($\text{H}-\text{C}\equiv\text{C}-\text{H}$) to produce a new bicyclic organic product. Sketch out and label the steps of the mechanism to convert **21** + acetylene to the free bicyclic organic product. You can use L to indicate the carbene ligand.

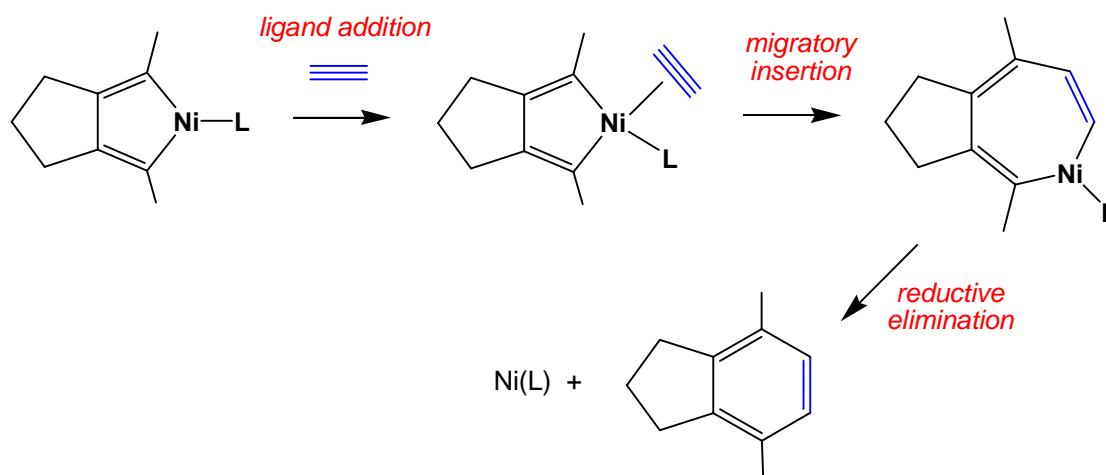

The reductive elimination here is easy due to the aromaticity and almost zero ring strain of the benzene ring system that is formed.

6. (20 pts) Sketch out and label the steps needed to take $\text{Ni}(\text{L})_n$ (use the n value from question # 3), CO_2 and diyne (use the diyne shown in Scheme 1) to complex **19** (Scheme 1). Based on the discussion in the text the order of CO_2 and alkyne coordination and subsequent “coupling” should be clear.

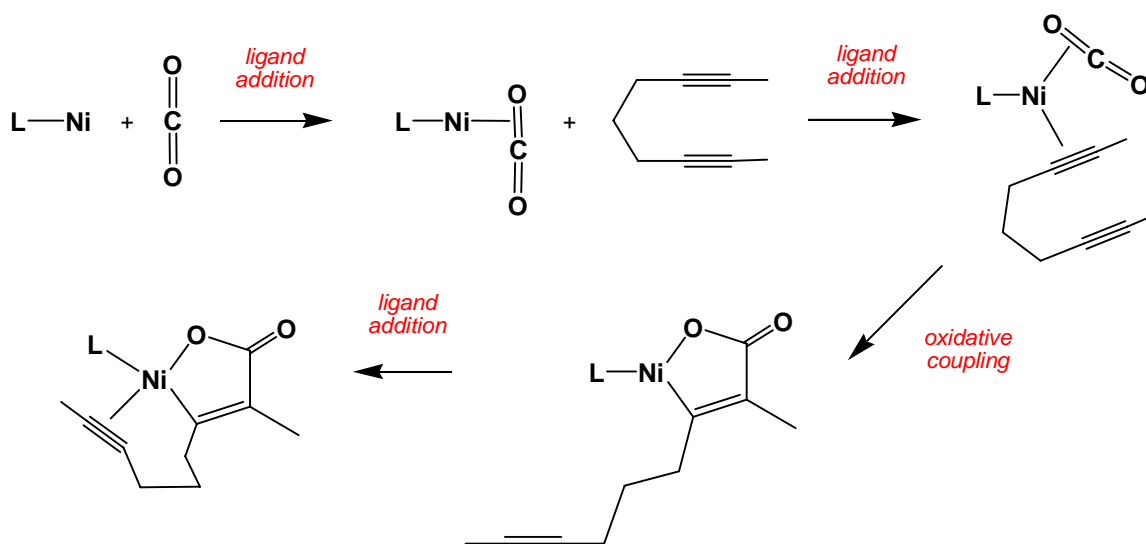

The steric bulk of the IPr ligand will limit coordination of both alkyne groups at the same time. The order of CO_2 and alkyne ligand addition is not especially important, but on the second page of the paper Prof. Louie comments that the reaction of **1** and $\text{Ni}(\text{IPr})_2$ is slow, while $\text{Ni}(\text{IPr})_2$ reacts quantitatively with CO_2 (we can also assume that this is fast). Thus the first step is probably CO_2 coordination.

7. (10 pts) The strong donor ability of the IPr carbene ligand play an important role in this reaction. What reaction step is most assisted by the strong donor property of the carbene? Discuss.

The oxidative coupling step. This should be the most difficult step as it involves coordinating and orienting both the alkyne and CO_2 correctly on the Ni center, followed by the oxidative addition/coupling reaction. Oxidative additions (and couplings) are favored by electron-rich metal centers and strong donor ligands. Her comment at the end of the paper about the reductive elimination step refers to the fact that the $\text{Ni}(\text{IPr})$ complex that remains after reductive elimination is only a $12e^-$ species and is very unsaturated. A strong donor ligand like IPr helps stabilize this kind of very unsaturated complex.

8. (10 pts) If this coupling reaction worked with $\text{S}=\text{C}=\text{O}$ and the diyne shown in Scheme 1, what would you expect the organic product (sketch out) to be based on what you should have learned in this course and why?

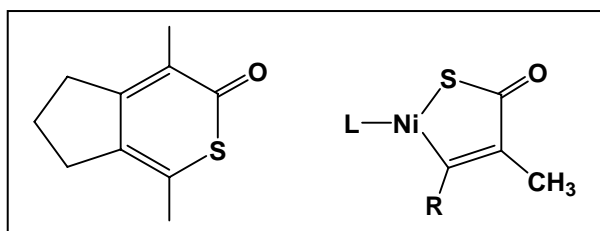

The organic product is shown to the far left. This will be the preferred product because of the thiophilicity (sulfur-loving) properties of the later transition metals. The S-Ni σ -bond (immediate left) is stronger than a Ni-O bond. The C=O double bond is also more stable than the C=S double bond, which will favor the nickel-cycle and organic product shown.

Exams

for the last 2 years

Followed by **Answer Keys**

Check this box if you want your graded test put out
in the public boxes outside Prof. Stanley's office:

Please answer all questions!

1. (60 pts) Sketch out the structure of the following transition metal complexes as accurately as possible and clearly show the electron counting for each. Clearly indicate ligand charges and metal oxidation states for your electron counting. You don't have to draw out phenyl rings on ligands (e.g., for PPh₃).

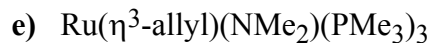
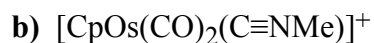
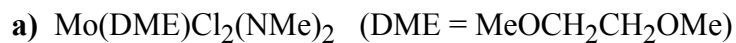

f) (10 pts) $(\kappa^2\text{-Ph}_2\text{PC}_2\text{H}_4\text{NEt}_2)\text{MePt-WCp(CO)}_3$ (electron count each metal)

g) $\text{Fe(NO)}_2(\text{CO})_2$

h) CpReO_3

i) $\text{CpMoCl}_2(\text{NO})$

j) $\text{IrH}_2\text{Cl(CO)(PPh}_3)_2$

k) $\text{Rh}_2(\mu\text{-S})(\text{dppm})_2(\text{CO})_2$ (dppm ligands are *trans* to one another)

2. (30 pts) For each of the following pairs of complexes, which will have the ***lowest*** average CO infrared stretching frequency? Circle your choice and briefly and clearly explain your reasoning.

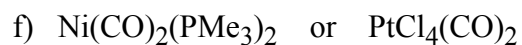
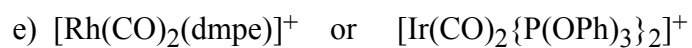
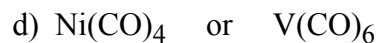
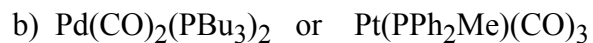
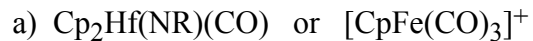

3. (20 pts) It is sometimes difficult to tell whether a ligand with more than one lone pair is donating 2 or 4e⁻ to the metal center. The amide $[\text{NR}_2]^-$ ligand, on the other hand, has a structural feature (not the M-NR₂ bond distance!) that usually tells one whether it is acting as a 2e⁻ or 4e⁻ donor. Clearly explain using simple structural diagrams (and words) the 2 and 4e⁻ bonding modes for amide to a metal center and what the structural marker is for these two coordination types.
4. (40 pts) Sketch out an 18-electron structure for the following metals and ligands. Use **at least one metal and each type of ligand shown**. Try to keep your structure as simple as possible and do NOT use more than two metal centers. **Show your electron counting.** Ligands are shown without charges, please indicate the proper ligand charge and metal oxidation state in your electron counting. Draw a reasonable structure showing the geometry about the metal center(s).
- a) Rh, $\mu\text{-Cl}$, CO, PMe₃
- b) Ta, C-R, N-R, dppe
- c) Cr, Cp, CR₂, CO
- d) Ru, benzene, H, C \equiv NMe

Check this box if you want your graded test put out
in the public boxes outside Prof. Stanley's office:

Please answer all questions!

1. (60 pts) Sketch out the structure of the following transition metal complexes as accurately as possible and clearly show the electron counting (including the oxidation state of the metal center and ligand charges if present). You don't have to draw out phenyl rings on ligands (e.g., for PPh_3).

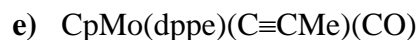
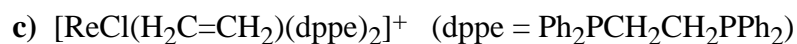
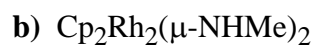
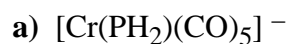

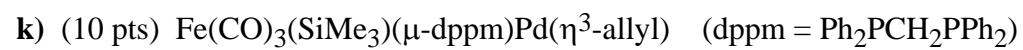
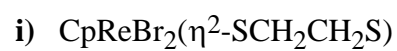
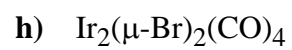
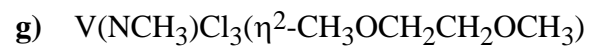
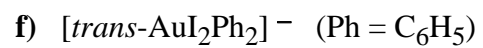

2. (30 pts) For each of the following pairs of complexes, which will have the lowest average CO infrared stretching frequency? Circle your choice and briefly explain your reasoning.

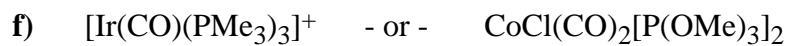
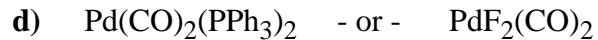
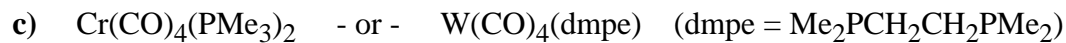
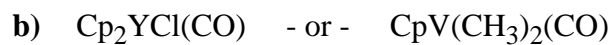
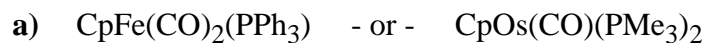

3. (20 pts) Consider the series of ligands shown below (drawn flat in Lewis dot structure style). (a) (5 pts) fill in the number of lone pairs present (use dots for electrons, big enough for us to clearly see) and indicate the appropriate charge on the ligand to give a filled octet.

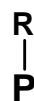
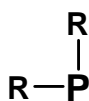
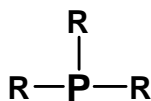

b) (5 pts) There are essentially no examples of PR_3 acting as a bridging ligand between two metal atoms. There are examples of bridging $\text{C}\equiv\text{O}$, $\text{C}\equiv\text{NR}$, $\text{N}\equiv\text{CR}$, H^- and CH_3^- (but generally not other alkyl ligands), where each of these ligands only has a single lone pair of electrons. Why can't PR_3 act as a bridging ligand when these others can?

c) (10 pts) PR_2 (charge not indicated, see part a), on the other hand, is a great bridging ligand. Why?

4. (40 pts) Sketch out an 18-electron structure showing the geometry about the metal center as accurately as you can at this point in the course for the following metals and ligands. Use *at least one metal and each type of ligand shown*. Try to keep your structure as simple as possible (bimetallic complexes are OK, nothing higher). Show your electron counting. Ligands are shown *without charges*, please indicate the proper ligand charge and metal oxidation state in your electron counting.

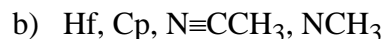

If you want your graded exam placed in the public racks
outside Prof. Stanley's office please place an X in this box:

1. (30 pts) Identify the following reactions by their type (migratory insertion, β -hydride elimination, oxidative addition, reductive elimination, associative substitution, dissociative substitution, ligand addition, ligand dissociation, ligand coordination change, oxidative coupling, etc.). Clearly indicate which ligands are involved in your reactions (e.g., migratory insertion of alkene and hydride). In some cases one may have to use more than one description for a reaction that may have several steps. If the order is important, list the steps in the correct order.

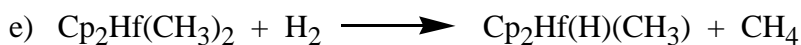
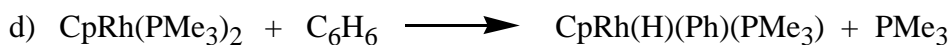
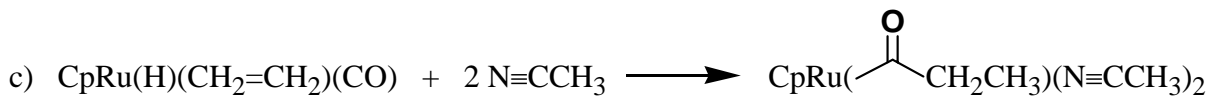
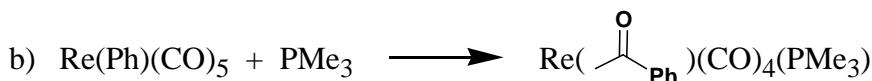
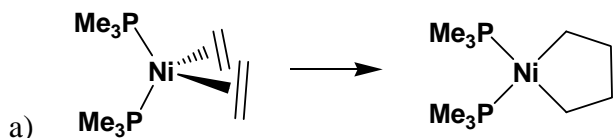

2. (25 pts) Circle the metal complex that will most readily dissociate (lose) a CO ligand. This is often important for the first step in a catalytic reaction. Briefly and clearly state your reasoning.

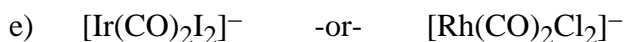
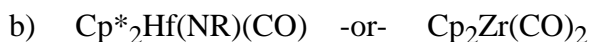
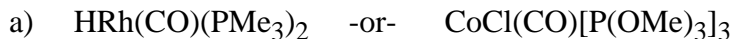

3. (25 pts) For each of the following pairs of metal complexes, circle the one that will **most** readily do an **oxidative addition** with the reactant shown. No discussion is necessary.

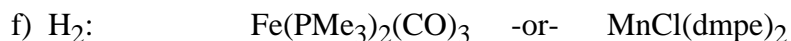
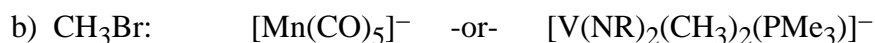

4. (10 pts) Consider the following two reactions:

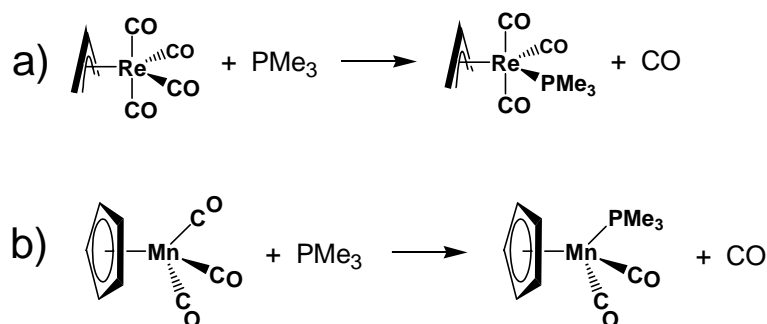

Circle the letter of the reaction (a or b) that is much faster. Discuss why this is so.

5. (10 pts) $\text{HRh}(\text{CO})(\text{PPh}_3)_2$ is widely used in industry as a hydroformylation catalyst (alkene + CO + $\text{H}_2 \longrightarrow$ aldehyde). Under H_2/CO pressure (and excess PPh_3) the dominant species present in solution is $\text{HRh}(\text{CO})_2(\text{PPh}_3)_2$. The rate determining step for this catalyst system is the coordination of alkene to give $\text{HRh}(\text{CO})(\text{alkene})(\text{PPh}_3)_2$. Explain why the catalyst is much slower if one uses PEt_3 ligands instead of PPh_3 .

6. (30 points) a) (20 pts) Label the reaction steps marked with an empty box in the following catalytic cycle for the Pd-catalyzed Heck coupling. Use the boxes provided and print clearly. A list of possible reaction steps is given in problem 1.

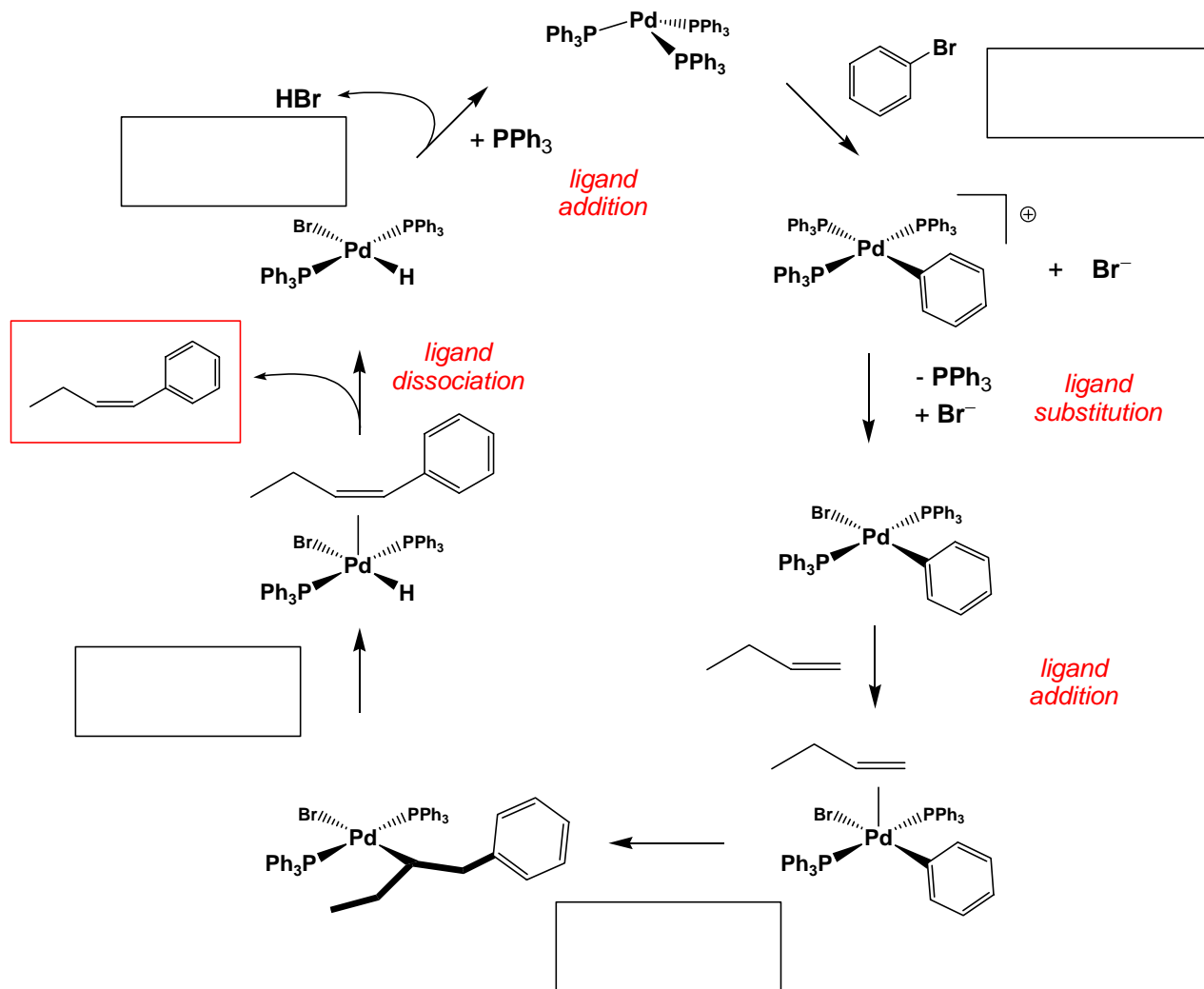

b) (10 pts) The bromide ligand substitution step on the right hand side could be either a dissociative substitution or an associative substitution. Make a short clear case for each possibility.

Associative Substitution:

Dissociative Substitution:

7. (20 points) Consider the following overall reaction:

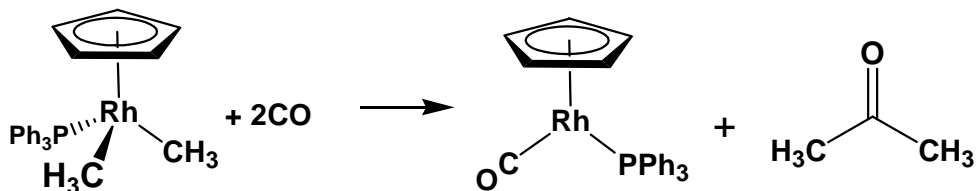

There are 5 steps to this reaction, with the last step being a simple ligand addition of PPh₃ to get to the Rh containing final product complex. **Clearly sketch out and label each step (one per line).** For substitution reactions, indicate the overall reaction (not as separate ligand addition/dissociation rxns) and whether it is an associative or dissociative substitution. When this was asked in class as a quiz question, very few got it correct. Let's see if you do better now. To make your drawing simpler, you may use a simple oval as an abbreviation for the Cp ring.

Check this box if you want your graded test put out
in the public boxes outside Prof. Stanley's office:

1. (40 points) Classify the following reactions as oxidative addition, reductive elimination, migratory insertion, elimination, β -hydride elimination, ligand substitution, ligand dissociation, ligand addition, oxidative coupling, hydrogenolysis (i.e., 4-center concerted H_2 activation & transfer), etc. There may be more than one step and that the equations are not necessarily balanced or completely list all possible products. If there is more than one step to label, make sure you list the steps in the correct order *if* the order is important. NO discussion or justification is necessary.

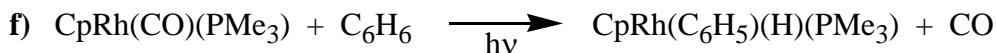
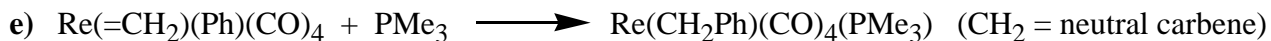
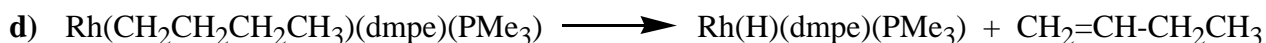
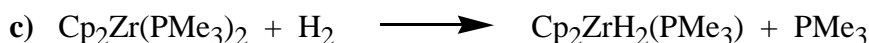
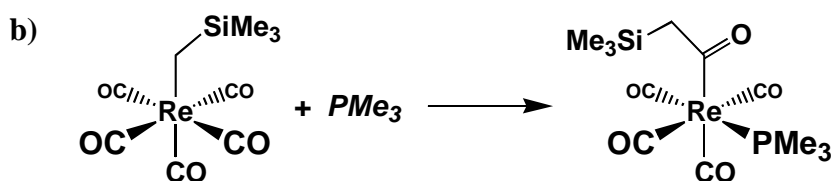
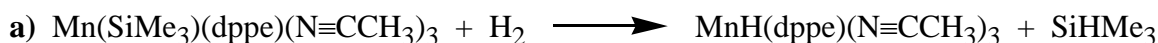

2. (20 pts) For each of the following pairs of metal complexes, circle the one that will *most readily* do an **oxidative addition** to the substrate shown. No discussion is necessary.

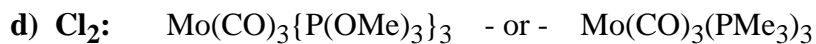
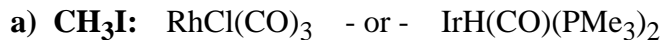

3. (30 pts) Use the boxes to label the following steps to identify what is going on in the following catalytic cycle (see choices listed from problem #1).

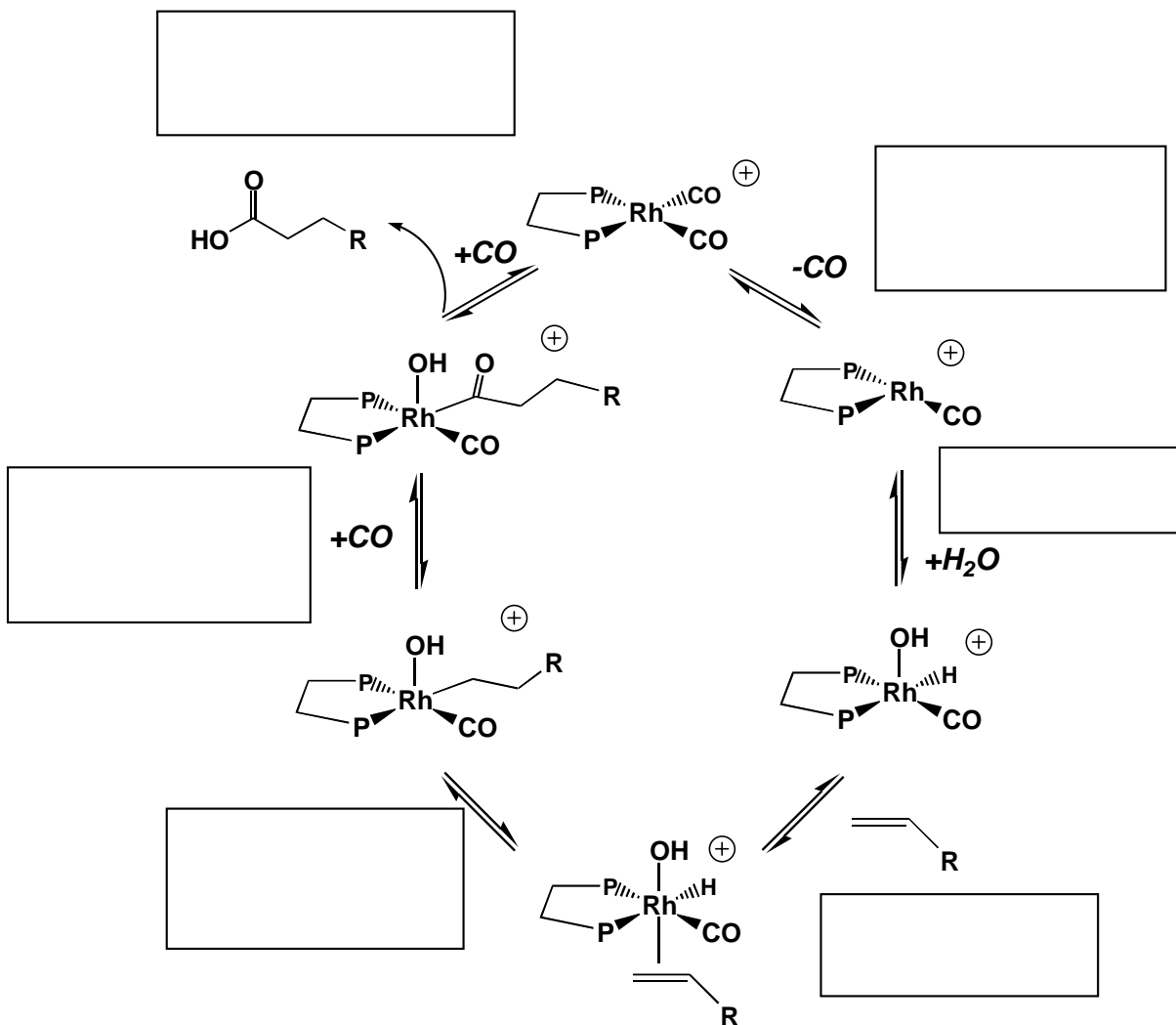

4. (20 points) a) (10 pts) Explain how the methyl and bromide ligands in the following reaction end up in the indicated positions. Use diagrams to clearly illustrate your vivid description of this process.

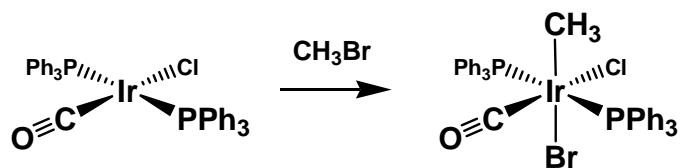

- b) (10 pts) The reaction of $\text{IrCl}(\text{CO})(\text{PPh}_3)_2$ with H_2 gives the *cis*-dihydride $\text{IrH}_2\text{Cl}(\text{CO})(\text{PPh}_3)_2$. Explain why this is different from part a) above.

5. (10 pts) $\text{Mo}(\text{CO})_3(\text{PMe}_3)_3$ is extremely **inert**, while $\text{Mo}(\text{CO})_2\{\text{P}(\text{OMe})_3\}_3(\text{CH}_3)$ is **quite reactive and easily substituted**. Briefly discuss the reasons for these differences.

6. (30 pts) Consider the following reaction that produces neopentane:

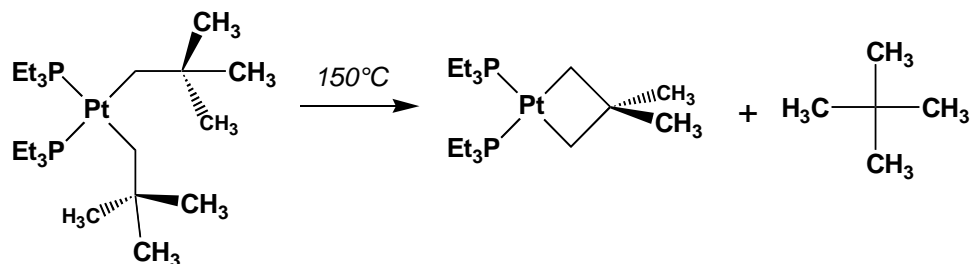

a) (20 pts) Sketch out a detailed mechanism based on the following steps: *1*) ligand dissociation, *2*) C-H oxidative addition, *3*) reductive elimination of neopentane product, *4*) ligand addition. The starting complex is shown below. Please use organic line notation for your *tert*-butyl groups (as shown below). Clearly draw your structures.

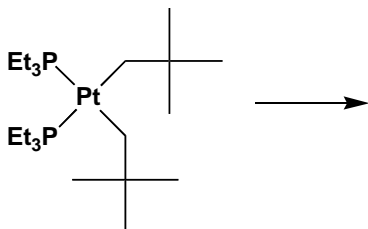

b) (5 pts) Is the geometry about the Pt center in the product closer to square planar or tetrahedral? Briefly discuss.

c) (5 pts) Why are the two alkyl groups in the starting Pt complex cisoidal when steric factors should favor a trans orientation?

Check this box if you want your graded test put out in the public boxes outside Prof. Stanley's office:

1. (50 pts) Shown below is a catalytic cycle for the oxidation of ethylene to make acetaldehyde. This is a famous commercial reaction called the Wacker process.

a) (35 pts) Label the reaction steps indicated in the boxes provided. There may be more than one step per box (but not more than 2). Possible reaction step descriptions include (but are not limited to): migratory insertion, elimination, β -hydride elimination, oxidative addition, reductive elimination, substitution (associative or dissociative), ligand addition, ligand coordination (hapticity) change, hydrogenolysis, deprotonation, protonation, nucleophilic attack, electrophilic attack, etc.

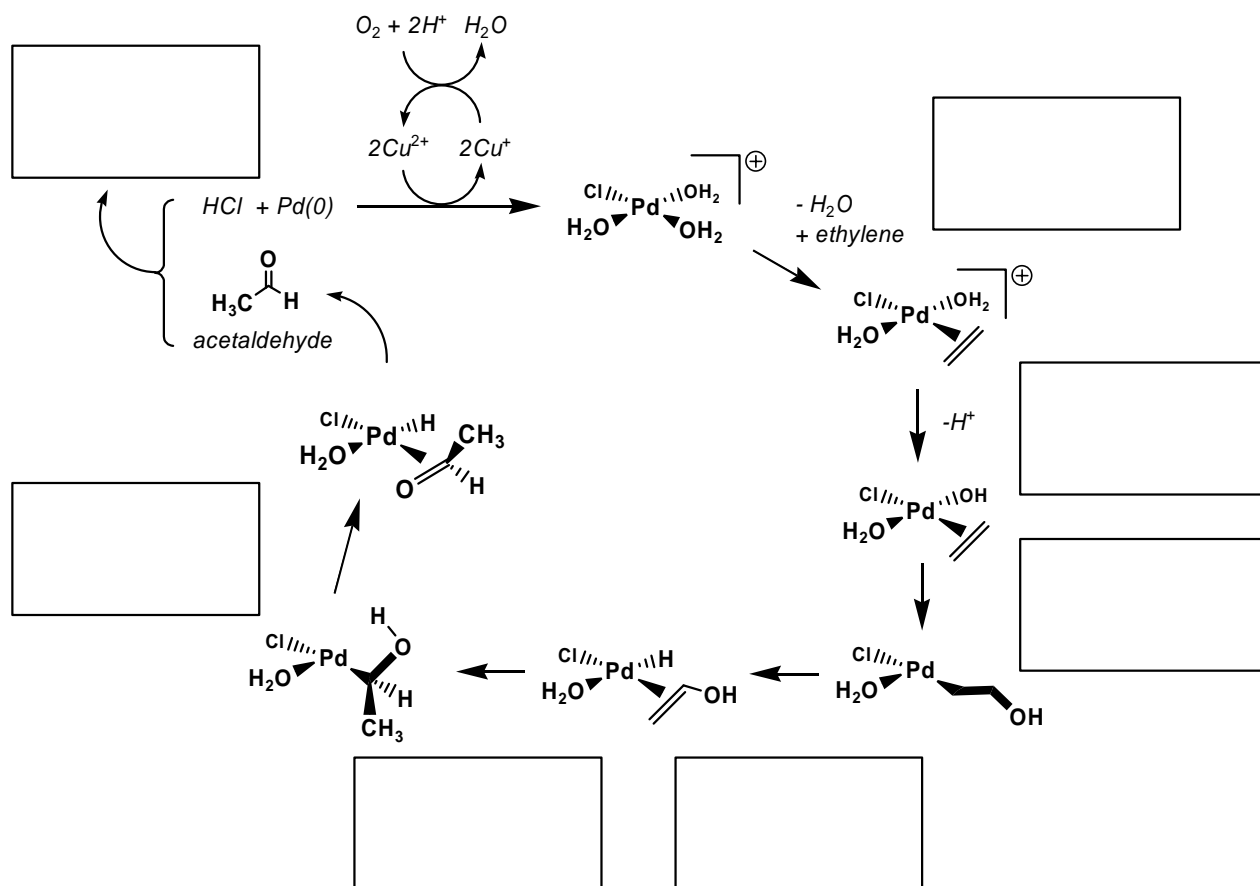

b) (5 pts) O_2 does not directly react with $\text{Pd}(0)$ to oxidize it to $\text{Pd}(+2)$. Based on this fact, briefly and clearly explain what is happening in the conversion of $\text{Pd}(0)$ to the $[\text{PdCl}(\text{H}_2\text{O})_3]^+$ complex at the top of the catalytic cycle.

c) (5 pts) I didn't balance the $O_2/H^+/Cu(+,+2)$ mini-cycle properly as it should really have been $\frac{1}{2}O_2$. The question here concerns the $2H^+$ that are balanced correctly. Where do the $2H^+$ come from? Is the catalytic reaction doing a net consumption of H^+ causing a solution pH change?

d) (5 pts) Why is the step that generates the neutral $PdCl(OH)(H_2O)(CH_2=CH_2)$ complex important?

2. (50 pts) Consider the following reaction called hydrovinylation from homework # 4:

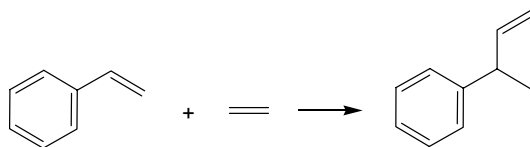

Clearly sketch out the catalytic cycle starting with $NiHCl(PCy_3)$ (shown below) with reasonably accurate structures based on the indicated sequence of steps:

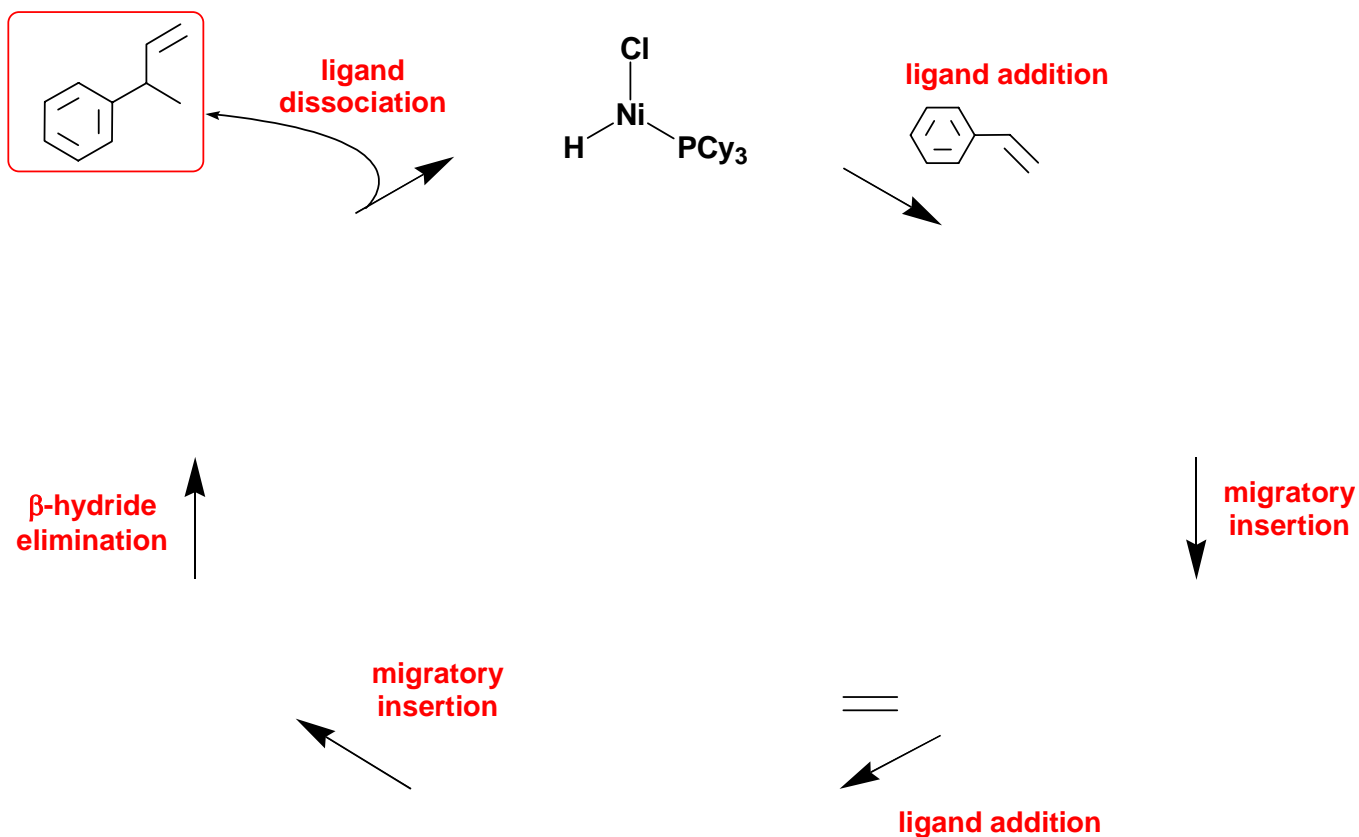

3. (50 pts) The cyclotrimerization of acetylene ($\text{H-C}\equiv\text{C-H}$) to benzene (shown below) is catalyzed by many metal complexes.

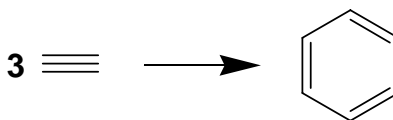

- a) (30 pts) Sketch out and label the steps for a catalytic cycle for this starting with the Ni complex shown below (*Hint*: first step is oxidative coupling).

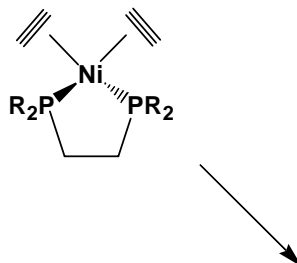

- b) (10 pts) Small alkylated phosphines make this catalyst work better. Discuss reasons for this observation.
- c) (10 pts) From an electronic viewpoint, would you want to put electron-donating or electron-withdrawing groups on the alkyne to make the reaction go faster (don't worry about steric effects). Clearly discuss.

4. (50 pts) Sketch out a reasonable catalytic cycle for the hydrogenation of ethylene to ethane using $\text{RuCl}_2(\text{PR}_3)_3$ as the catalyst and a **hydrogenolysis-type mechanism** (no oxidative addition of H_2 to the metal center). Label each step in your cycle.

5. (50 pts) a) (30 pts) Label the steps in the following catalytic cycle:

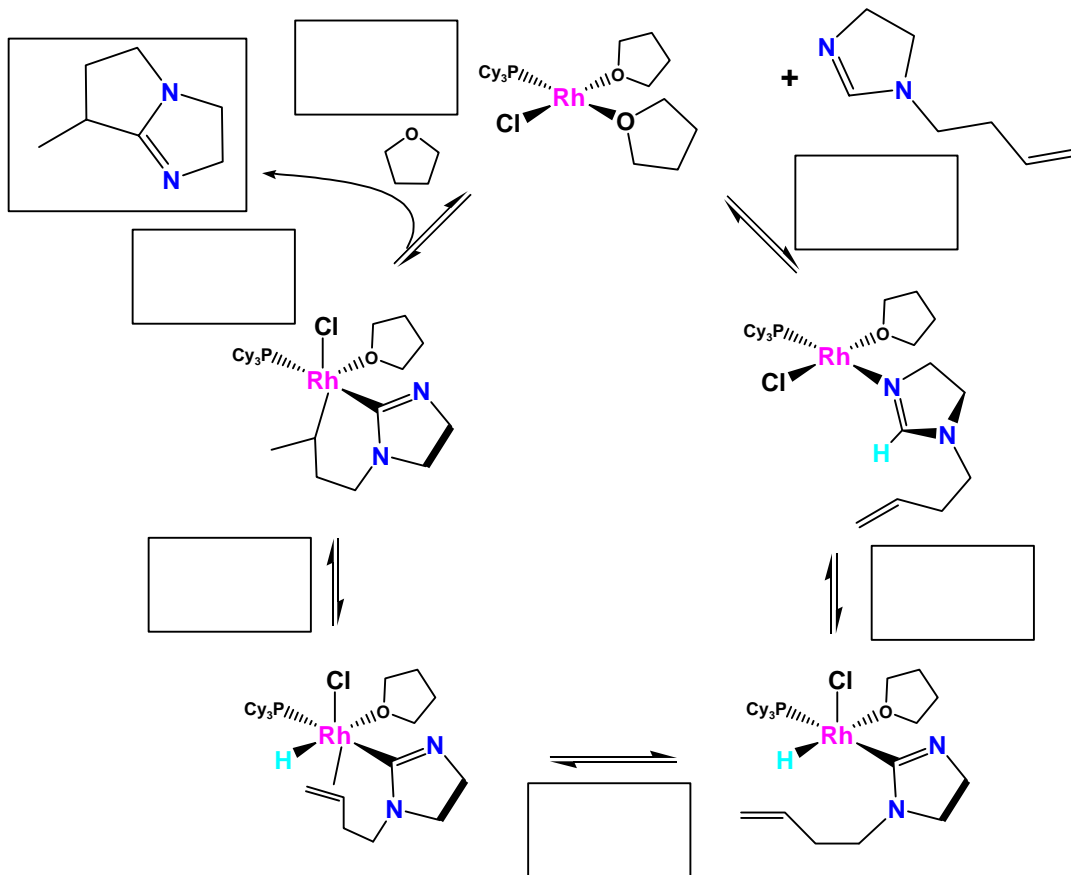

b) (5 pts) This catalytic reaction was run at 160-180°C with excess PCy₃, but I've only drawn the catalyst with one PCy₃ ligand. Why didn't I use two PCy₃ ligands on the catalyst?

c) (10 pts) One of the side reaction in the catalytic cycle is alkene isomerization to make the following product:

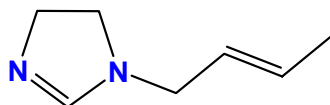

Write out the steps (with labels) showing how this happens starting with one of the complexes from the catalytic cycle.

d) (5 pts) Would you expect the following substrate to do the analogous cyclization reaction shown in the catalytic cycle in part a)? Explain and assume that no alkene isomerization can occur.

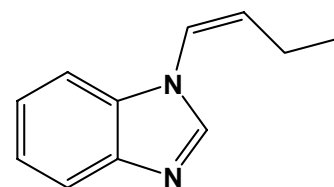

Check this box if you want your graded test put out in the public boxes outside Prof. Stanley's office:

1. (50 pts) Consider the following catalytic cycle for the Dupont dimerization of butadiene and ethylene (ethene) to produce 1,4-hexadiene.

a) (30 pts) Label each step identified with a box and describe what is happening (note that there may be more than one choice per step as written – if so, make sure that you list the steps in the correct order). P = P(OR)₃ in the catalytic cycle. The step #'s are for part c).

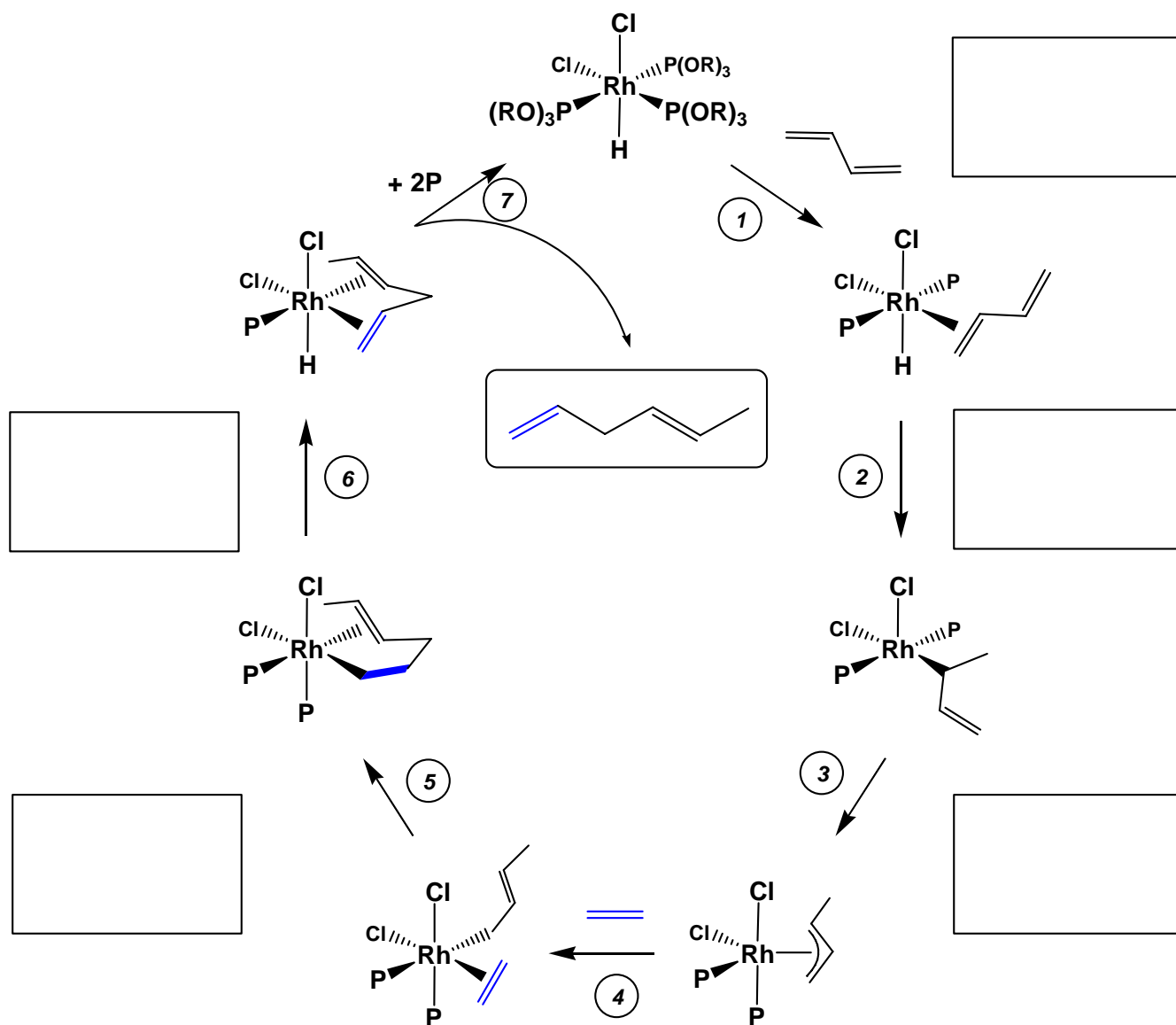

b) (10 pts) The authors are using $P(OR)_3$ ligands for this reaction. What are the main advantages these offer for the catalytic cycle relative to PR_3 ligands (R = alkyl group, assume same cone angles).

c) (10 pts) All but one of the steps in the catalytic cycle shown on the previous page are readily reversible (in equilibrium). Which step will have considerable difficulty going backwards (i.e., counter-clockwise)? Identify by the step number. Clearly (and briefly) discuss why.

2. (50 pts) $[PdX(CO)(bipy)]^+$ is an active catalyst (when X = H, CH_3) for the copolymerization of CO and ethylene to produce polyketones. **Key observations: This catalyst produces only perfectly alternating CO and ethylene (ethane links) groups in the polyketone product (no CO-CO links or $(CH_2)_{3,4}$ groupings). No aldehyde end groups are observed.**

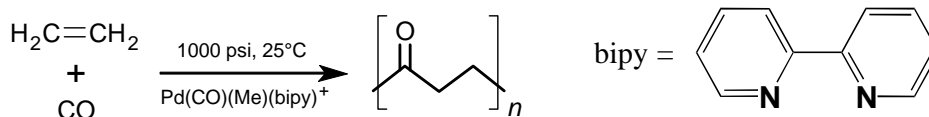

a) (30 pts) Sketch out the mechanism for polymerizing 2 CO and 2 ethylene molecules (don't draw it as a cycle). Use $[Pd(CH_3)(CO)(bipy)]^+$ as your starting catalyst (shown below, you can abbreviate the bipy ligand as two N's linked by a curved line). **Label each step of the reaction.** Your mechanism must account for the observations noted above.

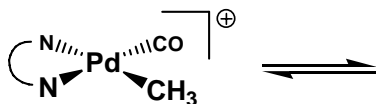

- b) (10 pts) The overall cationic charge on the Pd center is important for this catalysis for two main reasons. It promotes a key reaction step and it inhibits (reduces) a side reaction with CO that can dramatically reduce the activity of the catalyst. Briefly and clearly describe these and how the positive charge helps the catalysis.
- c) (10 pts) When the hydride complex $[\text{PdH}(\text{CO})(\text{bipy})]^+$ is the starting catalyst what is the first step in the chain growth process? Note that your answer must be consistent with the observations noted in the first part of the question.
3. (50 pts) One of the problems with late transition metal catalysts for ethylene polymerization is that they like to do β -hydride eliminations and are subject to a problem called “associative displacement” that cuts short the chain growing process.
- a) (15 pts) Sketch out a mechanism for this starting with the following complex that undergoes the following steps: 1) β -hydride elimination, 2) ethylene addition, 3) ligand dissociation. You can abbreviate the bis-imine ligand as shown in problem 2 for bipy, i.e., two N atoms connected by a curved line.

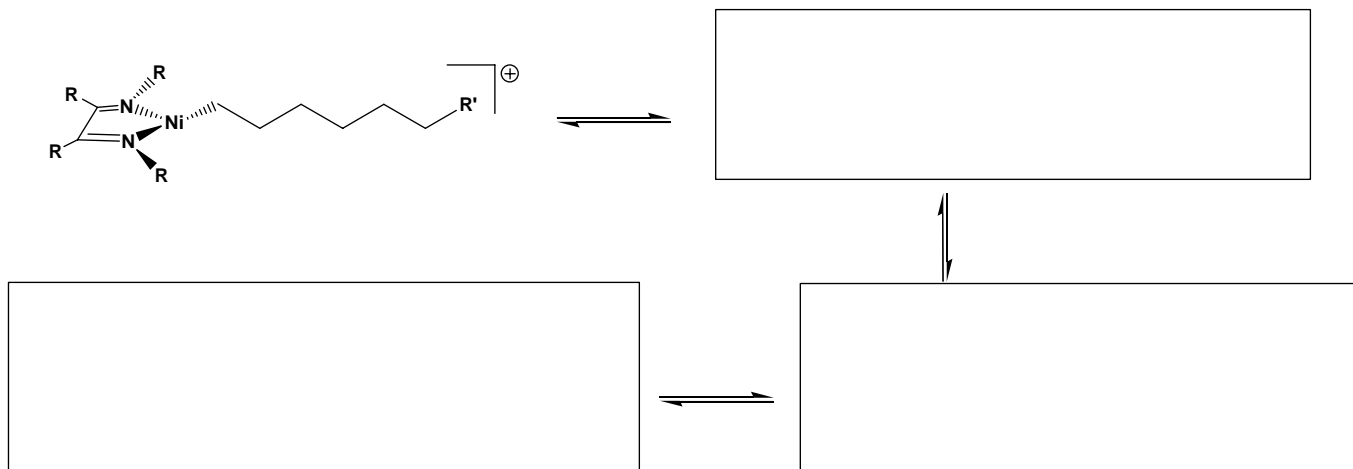

b) (25 pts) Prof. Maurice Brookhart used large bulky R groups on the bis-imine ligand designed to block the axial coordination sites on the d^8 metal center that prevented the associative displacement problem, but still allowed ligand coordination in the square plane (structure to right). This resulted in the first extremely good ethylene polymerization catalysts for Ni or Pd. These catalysts, however, have the unusual ability to make highly branched polyethylene via β -hydride eliminations coupled with migratory insertions – a process called “chain walking.” Shown below are the first several steps in a chain-walking isomerization that makes an ethyl branch in the polymer chain (note that I stop showing the alkyl/alkene group rotations after the first few). Complete the missing boxed structures. You can abbreviate the bis-imine ligand as done previously, i.e., two N atoms connected by a curved line.

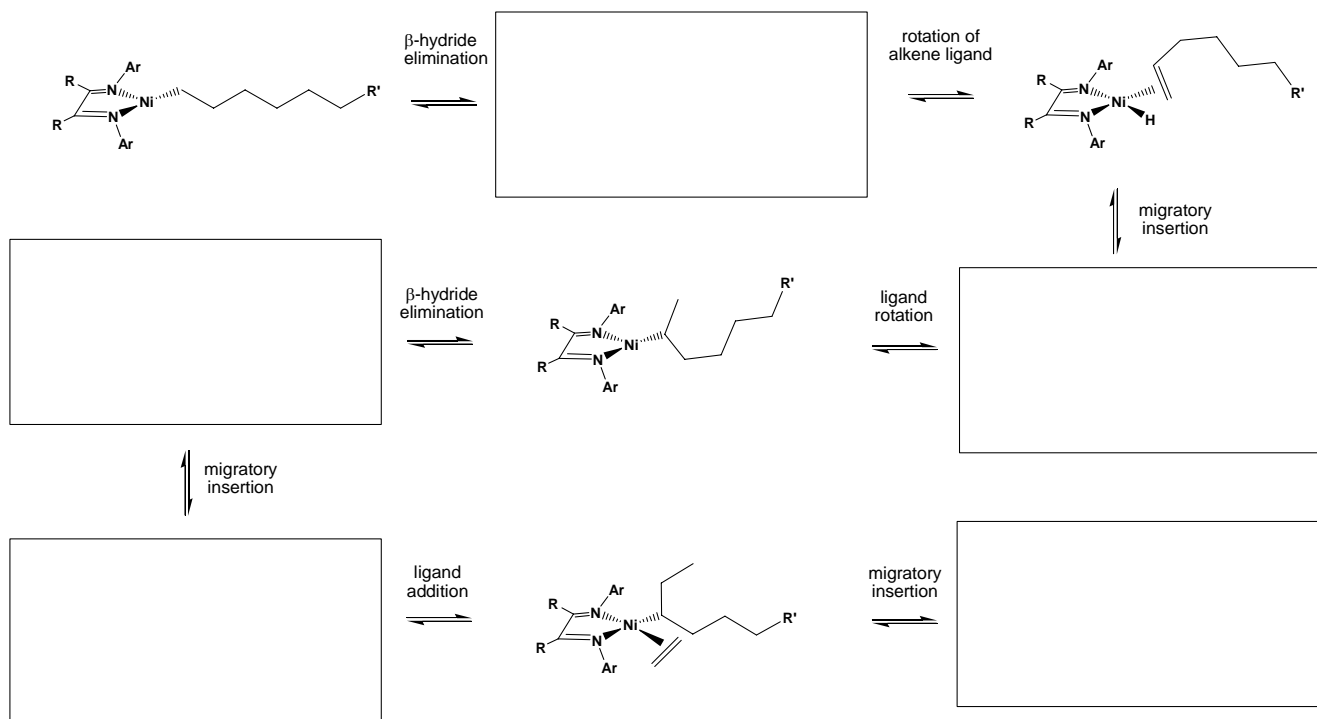
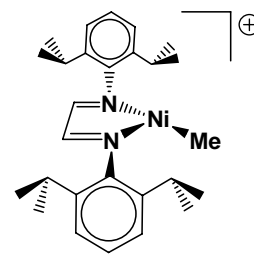

c) (10 pts) Increasing the ethylene pressure used in the catalysis reduces the amount of branching in the polyethylene produced. Why?

4. (50 pts) Sketch out a catalytic cycle for the following reaction using the starting catalyst complex shown below. Clearly label and identify each step.

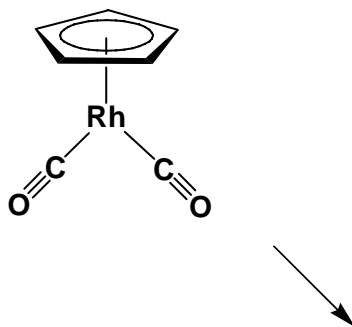
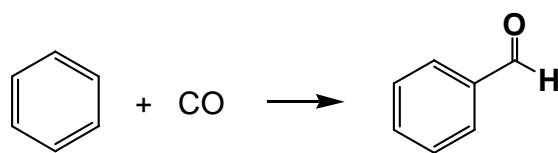

5. (50 pts) Shown below is the isomerization of 1-butene proceeding by the “allylic” mechanism.

a) (20 pts) label the steps with the boxes. If there is more than one step occurring, put them in the correct order if the order is important.

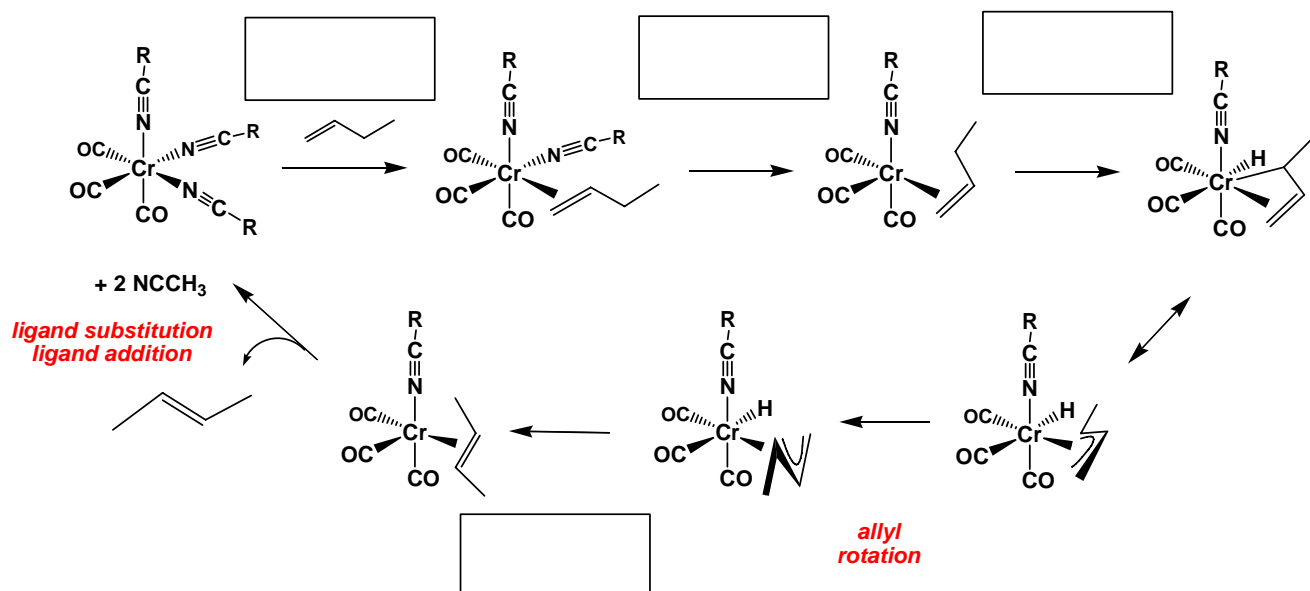

b) (10 pts) Why is it important for the allyl ligand to “rotate” in the step above.

c) (20 pts) Sketch out a mechanism for the isomerization of 1-butene via the “hydride” mechanism starting with HRh(dmpe)(N≡C-R). Clearly label each step.

Check this box if you want your graded test put out
in the public boxes outside Prof. Stanley's office:

Please answer all questions!

1. (60 pts) Sketch out the structure of the following transition metal complexes as accurately as possible and clearly show the electron counting for each. Clearly indicate ligand charges and metal oxidation states for your electron counting. You don't have to draw out phenyl rings on ligands (e.g., for PPh₃).

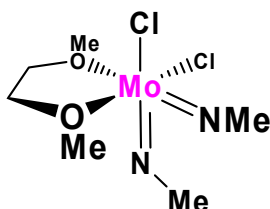
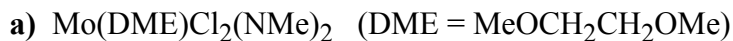

Mo(+6)	0e-
2Cl ⁻	4e-
2NR ²⁻	8e-
dme	4e-
Total	16 e-

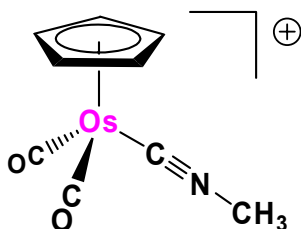
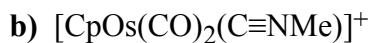

Os(+2)	6e-
Cp ⁻	6e-
C≡NCH ₃	2e-
2 CO	4e-
Total	18 e-

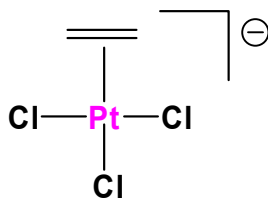

Pt(+2)	8e-
3Cl ⁻	6e-
C=C	2e-
Total	16 e-

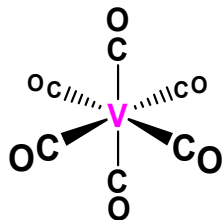

V(0)	5e-
6CO	12e-
Total	17 e-

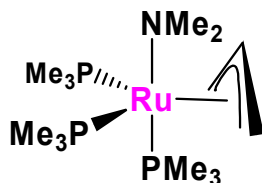
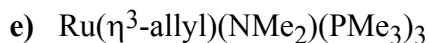

Ru(+2)	6e-
NMe ₂ ⁻	2e-
3PMe ₃	6e-
allyl ⁻	4e-
Total	18 e-

f) (10 pts) (κ^2 -Ph₂PC₂H₄NEt₂)MePt-WCp(CO)₃ (electron count each metal)

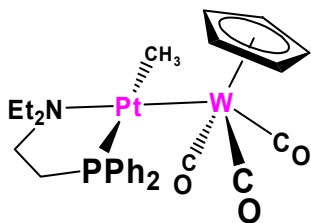

Pt(+1)	d9
P-N	4e-
CH ₃ ⁻	2e-
Pt-W	1e-
Total	16e-

W(+1)	d5
Cp ⁻	6e-
3CO	6e-
Pt-W	1e-
Total	18e-

g) Fe(NO)₂(CO)₂

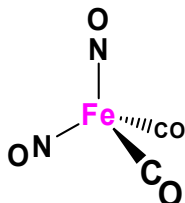

Fe(-2)	10e-
2NO ⁺	4e-
2CO	4e-
Total	18 e-

h) CpReO₃

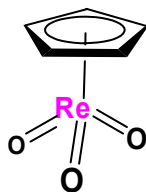

Re(+7)	0e-
Cp ⁻	6e-
3 O ²⁻	12e-
Total	18 e-

i) CpMoCl₂(NO)

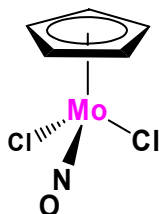

Mo(+2)	4e-
Cp ⁻	6e-
2Cl ⁻	4e-
NO ⁺	2e-
Total	16 e-

j) IrH₂Cl(CO)(PPh₃)₂

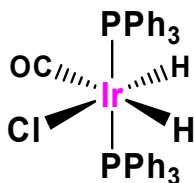

Ir(+3)	6e-
2PPh ₃	4e-
2H ⁻	4e-
Cl ⁻	2e-
CO	2e-
Total	18 e-

k) Rh₂(μ-S)(dppm)₂(CO)₂ (dppm ligands are *trans* to one another)

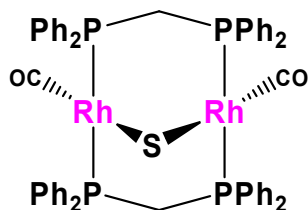

Rh(+1)	8e-
2dppm	4e-
μ-S ²⁻	2e-
CO	2e-
Total	16 e-

2. (30 pts) For each of the following pairs of complexes, which will have the **lowest** average CO infrared stretching frequency? Circle your choice and briefly and clearly explain your reasoning.

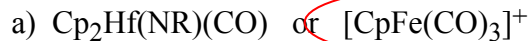

Hf is in the +4 oxidation state and is d^0 . Therefore it cannot do any π -backbonding to the CO ligand. The Fe complex is d^6 and can π -backbond to the CO ligand giving a lower CO stretching frequency.



Two PBU_3 ligands on the Pd are considerably better donors compared to one PPh_2Me ligand on the Pt complex. The Pt complex also has an extra CO ligand that will compete with the others for π -backbonding, meaning that each gets less. So the Pd complex will be more electron rich and have the lower CO stretching frequency.



The Os is more electron-rich due to the presence of two strongly donating methyl anions and an overall anionic charge. There is also only one CO present that can get the maximum π -backbonding.

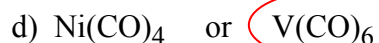

The V center is more electron-rich due to its low electronegativity that more than compensates for the fact that it only has 5 d electrons. It is also in the zero oxidation state that is highly unusual for V that usually strongly prefers the +3 or +5 oxidation states.

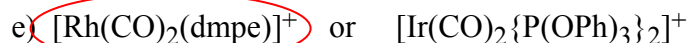

dmpe ($\text{Me}_2\text{PCH}_2\text{CH}_2\text{PMe}_2$) is an alkylated chelating phosphine that is a strong donor making the Rh center more electron-rich compared to the Ir center that has 2 poorly donating phosphite ligands.

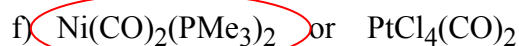

The Ni center is more electron-rich due to presence of 2 strongly donating alkylated phosphine ligands. The Pt center is in a relatively high oxidation state (+4) with relatively poorly donating chloride ligands.

3. (20 pts) It is sometimes difficult to tell whether a ligand with more than one lone pair is donating 2 or 4e- to the metal center. The amide $[\text{NR}_2]^-$ ligand, on the other hand, has a structural feature (not the M-NR₂ bond distance!) that usually tells one whether it is acting as a 2e- or 4e- donor. Clearly explain using simple structural diagrams (and words) the 2 and 4e- bonding modes for amide to a metal center and what the structural marker is for these two coordination types.

Pyramidal geometry about the M-NR₂ ligand indicates 2e- donation with the second pair of electrons on the amide ligand localized as a lone pair directed away from the metal. Trigonal planar geometry about the amide indicates 4e- donor and a formal double bond to the metal center (sp^2 hybridization about the amide nitrogen center).

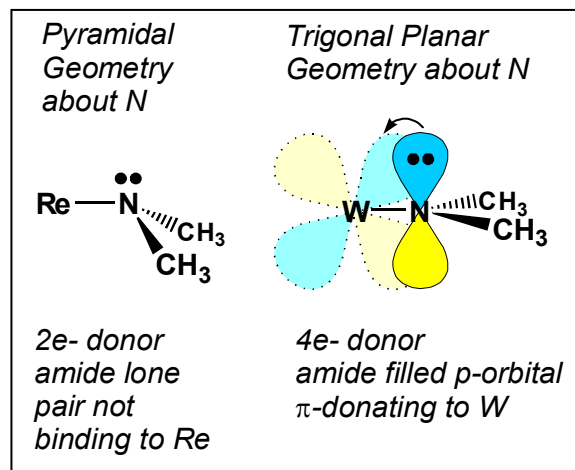

4. (40 pts) Sketch out an 18-electron structure for the following metals and ligands. Use **at least one metal and each type of ligand shown**. Try to keep your structure as simple as possible and do NOT use more than two metal centers. **Show your electron counting.** Ligands are shown *without charges*, please indicate the proper ligand charge and metal oxidation state in your electron counting. Draw a reasonable structure showing the geometry about the metal center(s).

a) Rh, μ -Cl, CO, PMe_3

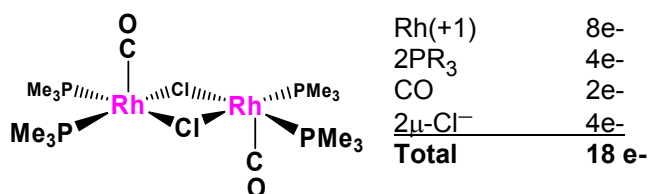

b) Ta, C-R, N-R, dppe

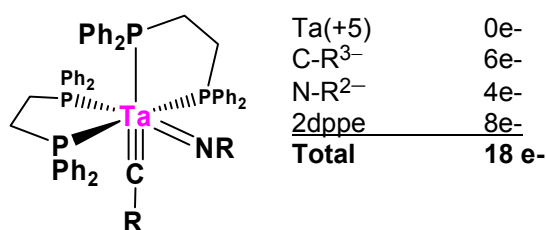

c) Cr, Cp, CR₂, CO

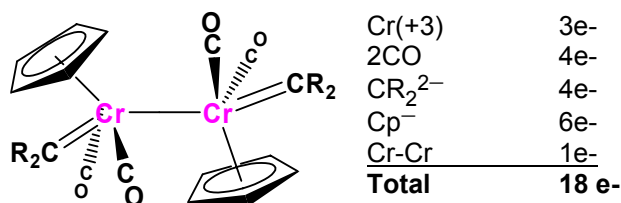

d) Ru, benzene, H, C \equiv NMe

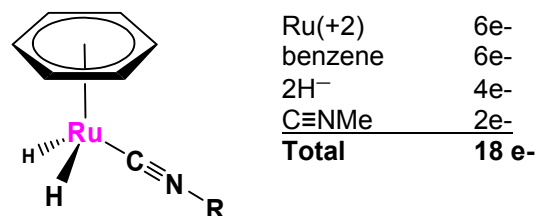

Check this box if you want your graded test put out
in the public boxes outside Prof. Stanley's office:



Please answer all questions!

1. (60 pts) Sketch out the structure of the following transition metal complexes as accurately as possible and clearly show the electron counting (including the oxidation state of the metal center and ligand charges if present). You don't have to draw out phenyl rings on ligands (e.g., for PPh₃).

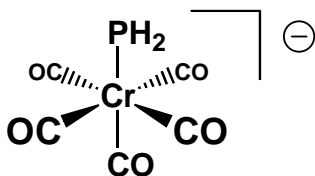
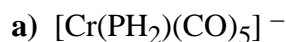

Cr(0)	6e-
PH ₂ ⁻	2e-
5 CO	10e-
Total	18 e-

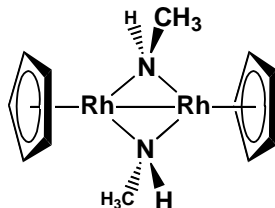
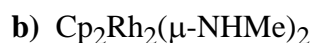

Rh(+2)	7e-
Cp ⁻	6e-
2 μ-NHMe ⁻	4e-
Rh-Rh	1e-
Total	18 e-

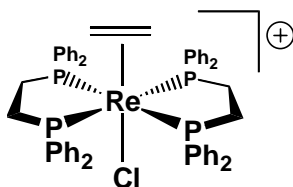
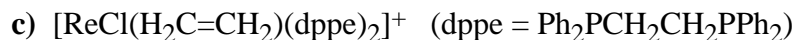

Re(+2)	5e-
Cl ⁻	2e-
C=C	2e-
2 dppe	8e-
Total	17 e-

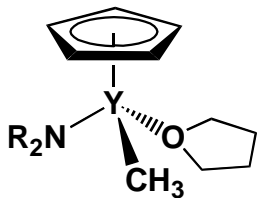

Y(+3)	0e-
Cp ⁻	6e-
NR ₂ ⁻	4e-
CH ₃ ⁻	2e-
THF	2e-
Total	14 e-

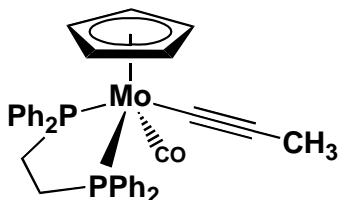

Mo(+2)	4e-
Cp ⁻	6e-
CCR ⁻	2e-
dppe	4e-
CO	2e-
Total	18 e-

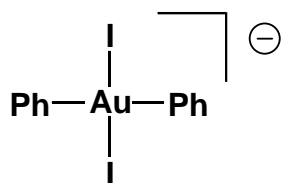
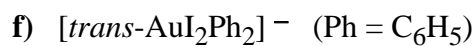

Au(+3)	8e-
2Ph ⁻	4e-
2I ⁻	4e-
Total	16 e-

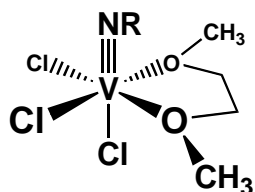
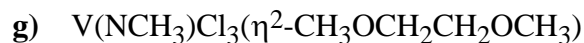

V(+5)	0e-
NR ⁻²	6e-
2 R-O-R	4e-
3Cl ⁻	6e-
Total	16 e-

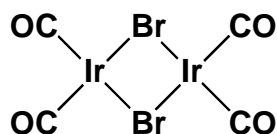
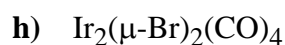

Ir(+1)	8e-
2μ-Br ⁻	4e-
2CO	4e-
Total	16 e-

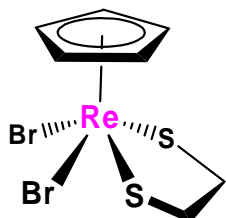
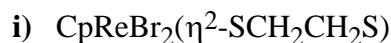

Re(+5)	2e-
Cp ⁻	6e-
2 SR ⁻	4e-
2 Br ⁻	4e-
Total	16 e-

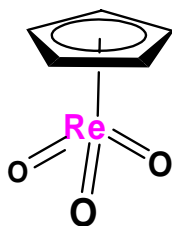

Re(+7)	0e-
Cp ⁻	6e-
3 O ²⁻	12e-
Total	18 e-

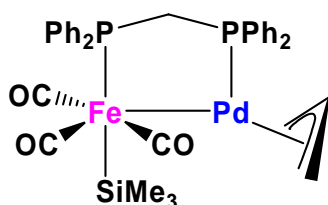

Fe(+1)	7e-	Pd(+1)	9e-
SiMe ₃ ⁻	2e-	allyl ⁻	4e-
3 CO	6e-	dppm	2e-
dppm	2e-	Fe-Pd	1e-
Fe-Pd	1e-	Total	16 e-
Total	18 e-		

2. (30 pts) For each of the following pairs of complexes, which will have the lowest average CO infrared stretching frequency? Circle your choice and briefly explain your reasoning.

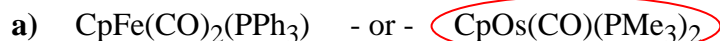

The most electron-rich metal will π -backbond the most with the CO ligands and have the lowest CO stretching

The Os complex has two strongly donating PMe_3 groups and only one π -backbonding CO, thus this one CO ligand will π -backbond more strongly with the metal center. The Os is also less electronegative and will be willing to π -backbond more strongly to the CO.

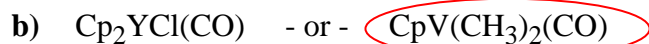

The Y complex is a d^0 system and can not π -backbond to the CO. The V complex, on the other hand, is a d^2 complex and has strongly donating Cp^- and CH_3^- groups

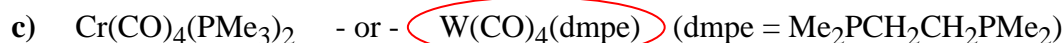

One dmpe ($\text{Me}_2\text{PCH}_2\text{CH}_2\text{PMe}_2$) ligand is approximately equivalent to two PMe_3 ligands with regards to their e-donating abilities. The only other difference is that W is less electronegative and will be more willing to π -backbond to the CO's.



The Pd(0) complex is more electron-rich. The Pd(+2) complex has very poor donating F- ligands, which due to their very high electronegativity donate very little e- density to the Pd(+2) center.



The Fe complex is in the -2 oxidation state and is very electron-rich. This more than compensates for the higher electronegativity relative to Cr. Thus there will be very strong π -backbonding between the Fe and CO ligands leading to a very low CO stretching frequency and very strong Fe-CO bond. The $\text{Cr}(\text{CO})_6$ complex is the more electron deficient and has the higher CO stretching frequency (less π -backbonding) and weaker M-CO bonding.

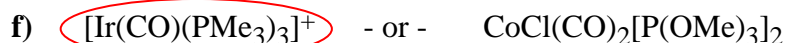

Although the Ir complex is cationic it has 3 very strongly donating PMe_3 ligands that compensate for this. This, combined with the lower electronegativity of the Ir center should give considerable π -backbonding for the single CO ligand present. The Co complex has poorer donating ligands, the phosphite ligands can also π -backbond, and there are two carbonyls present.

3. (20 pts) Consider the series of ligands shown below (drawn flat in Lewis dot structure style). (a) (5 pts) fill in the number of lone pairs present (use dots for electrons, big enough for us to clearly see) and indicate the appropriate charge on the ligand to give a filled octet.

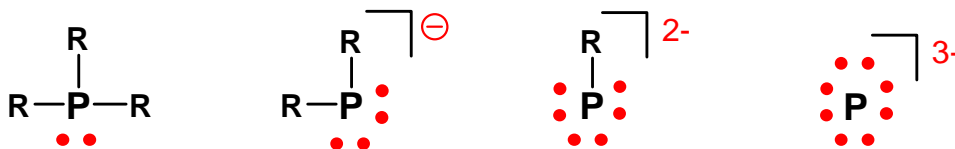

b) (5 pts) There are essentially no examples of PR_3 acting as a bridging ligand between two metal atoms. There are examples of bridging $\text{C}\equiv\text{O}$, $\text{C}\equiv\text{NR}$, $\text{N}\equiv\text{CR}$, H^- and CH_3^- (but generally not other alkyl ligands), where each of these ligands only has a single lone pair of electrons. Why can't PR_3 act as a bridging ligand when these others can?

Steric factors! The three R groups on the phosphine block its ability to bridge two metal centers. This is apparently true even if they are very small. All the other 2e- bridging ligands listed are "skinny" (i.e. sterically small) and can get close enough to both metal centers to share the single lone pair of electrons.

c) (10 pts) PR_2 (charge not indicated, see part a), on the other hand, is a great bridging ligand. Why?

The PR_2^- ligand is a great bridging ligand because it has one less R group (not sterically blocked like PR_3), an anionic charge, and two lone pairs of electrons perfectly oriented to bridge two metal centers.

4. (40 pts) Sketch out an 18-electron structure showing the geometry about the metal center as accurately as you can at this point in the course for the following metals and ligands. Use *at least one metal and each type of ligand shown*. Try to keep your structure as simple as possible (bimetallic complexes are OK, nothing higher). Show your electron counting. Ligands are shown *without charges*, please indicate the proper ligand charge and metal oxidation state in your electron counting.

a) W, $\mu\text{-PR}_2$, CO, H

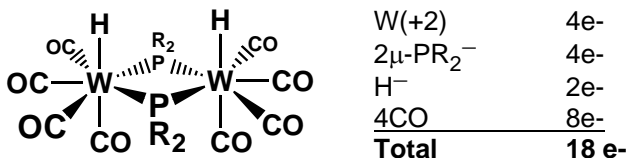

b) Hf, Cp, $\text{N}\equiv\text{CCH}_3$, NCH_3

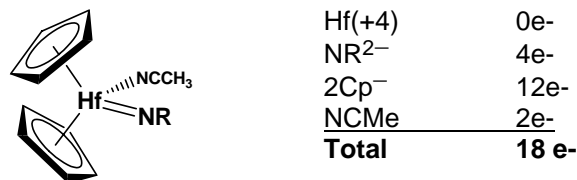

c) Pt, CH, Cl, PMe_3

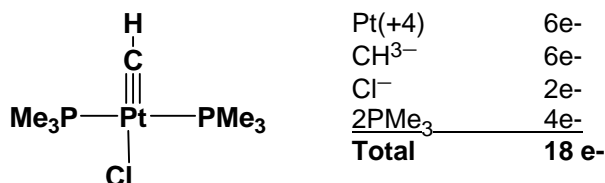

d) Nb, O, CH_3 , Cp, PMe_3

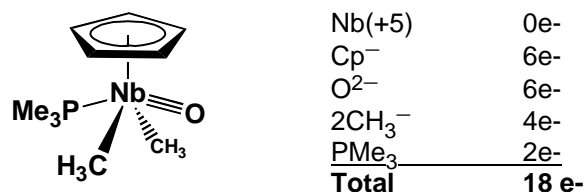

EXAM # 2 -- April 22, 2004

If you want your graded exam placed in the public racks outside Prof. Stanley's office please place an X in this box:

1. (30 pts) Identify the following reactions by their type (migratory insertion, β -hydride elimination, oxidative addition, reductive elimination, associative substitution, dissociative substitution, ligand addition, ligand dissociation, ligand coordination change, oxidative coupling, etc.). Clearly indicate which ligands are involved in your reactions (e.g., migratory insertion of alkene and hydride). In some cases one may have to use more than one description for a reaction that may have several steps. If the order is important, list the steps in the correct order.

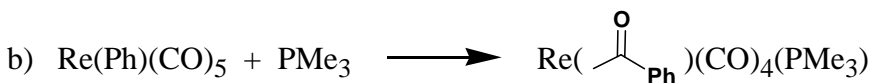
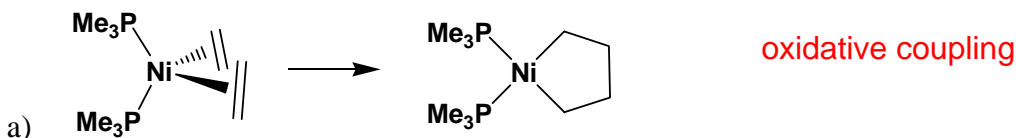

- 1) migratory insertion (CO and Ph)
- 2) ligand addition (PMe_3)

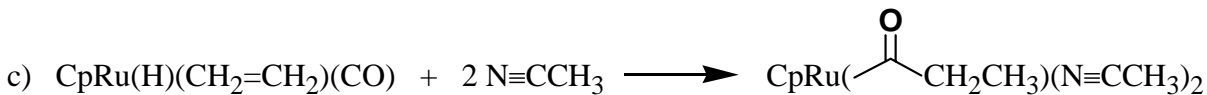

- 1) migratory insertion (H and ethylene to make an ethyl group)
- 2) ligand addition ($\text{N}\equiv\text{CMe}$)
- 3) migratory insertion (Et and CO)
- 4) ligand addition ($\text{N}\equiv\text{CMe}$)

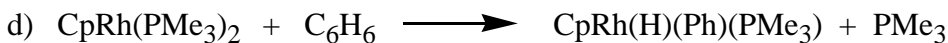

- 1) ligand dissociation (PMe_3)
- 2) oxidative addition (C_6H_6)

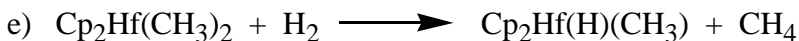

hydrogenolysis



- reductive elimination -or- PMe_3 ligand dissociation
 reductive elimination (CH_3Cl)
 PMe_3 ligand addition

You are looking for the least electron-rich (or d^0) complex that will have the smallest amount of π -backbonding to the CO

2. (25 pts) Circle the metal complex that will most readily dissociate (lose) a CO ligand. This is often important for the first step in a catalytic reaction. Briefly and clearly state your reasoning.

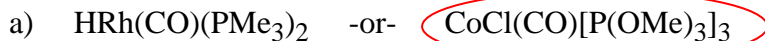

The Co complex has the poorest donor ligands and will dissociate the CO the easiest.



The Hf complex is d^0 and will have minimal π -backbonding to the CO

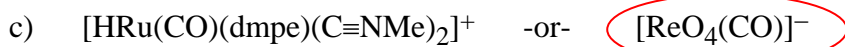

The Re complex is d^0



The Ir complex has poorer donating bridging chloride ligands relative to the Rh complex that has more electron-rich, stronger donating bridging phosphide ligands.

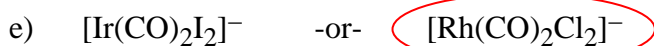

The Rh complex has poorer donating chloride ligands making it less electron-rich than the Ir complex.

3. (25 pts) For each of the following pairs of metal complexes, circle the one that will **most** readily do an **oxidative addition** with the reactant shown. No discussion is necessary.



Iodide is a stronger donating ligand that makes the Rh more electron-rich. It will not sterically block the small H_2

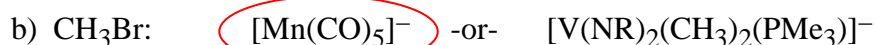

The V complex is d^0 and can't do an oxidative addition

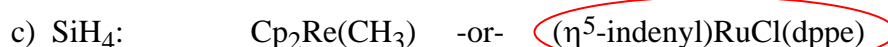

The indenyl ligand can shift to η^3 opening up the required empty orbital for the SiH_4 to coordinate



The W complex is d^0 and can't do an oxidative addition

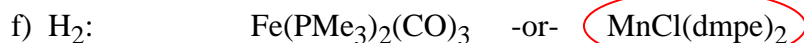

The Fe complex is 18e- with strongly coordinated ligands, while the Mn complex is 16e- (d^6)

4. (10 pts) Consider the following two reactions:

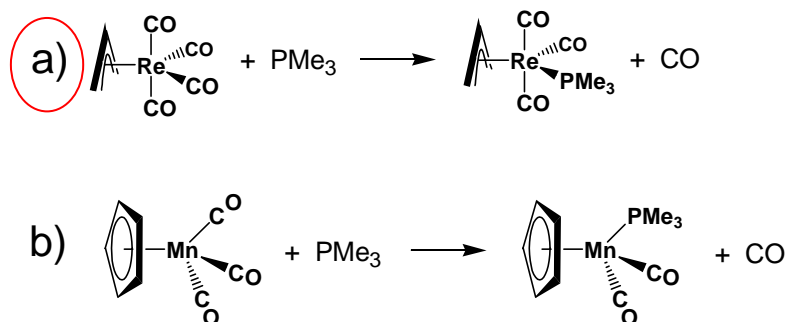

Circle the letter of the reaction (a or b) that is much *faster*. Discuss why this is so.

Both complexes are 18e⁻ saturated. But the allyl ligand on the Re complex can easily switch between η^3 - and η^1 -coordination modes. In doing so it will open up a free coordination site on the metal center allowing a more facile associative substitution reaction. This more than compensates for the third-row stronger metal-ligand bonding effect.

5. (10 pts) $\text{HRh}(\text{CO})(\text{PPh}_3)_2$ is widely used in industry as a hydroformylation catalyst (alkene + $\text{CO} + \text{H}_2 \longrightarrow$ aldehyde). Under H_2/CO pressure (and excess PPh_3) the dominant species present in solution is $\text{HRh}(\text{CO})_2(\text{PPh}_3)_2$. The rate determining step for this catalyst system is the coordination of alkene to give $\text{HRh}(\text{CO})(\text{alkene})(\text{PPh}_3)_2$. Explain why the catalyst is much slower if one uses PEt_3 ligands instead of PPh_3 .

The replacement of PPh_3 with the stronger donating PEt_3 ligands will make the Rh center considerably more electron-rich leading to stronger π -backbonding of the carbonyl ligands with the Rh center. It is important for one of the CO ligands to fall off the 18e⁻ $\text{HRh}(\text{CO})_2(\text{PR}_3)_2$ in order to open up a coordination site for the alkene to bond to, thus starting the hydroformylation catalysis. This is the rate determining step and making this step more difficult by increasing the strength of the Rh-CO bonds will dramatically slow the catalysis.

6. (30 points) a) (20 pts) Label the reaction steps marked with an empty box in the following catalytic cycle for the Pd-catalyzed Heck coupling. Use the boxes provided and print clearly. A list of possible reaction steps is given in problem 1.

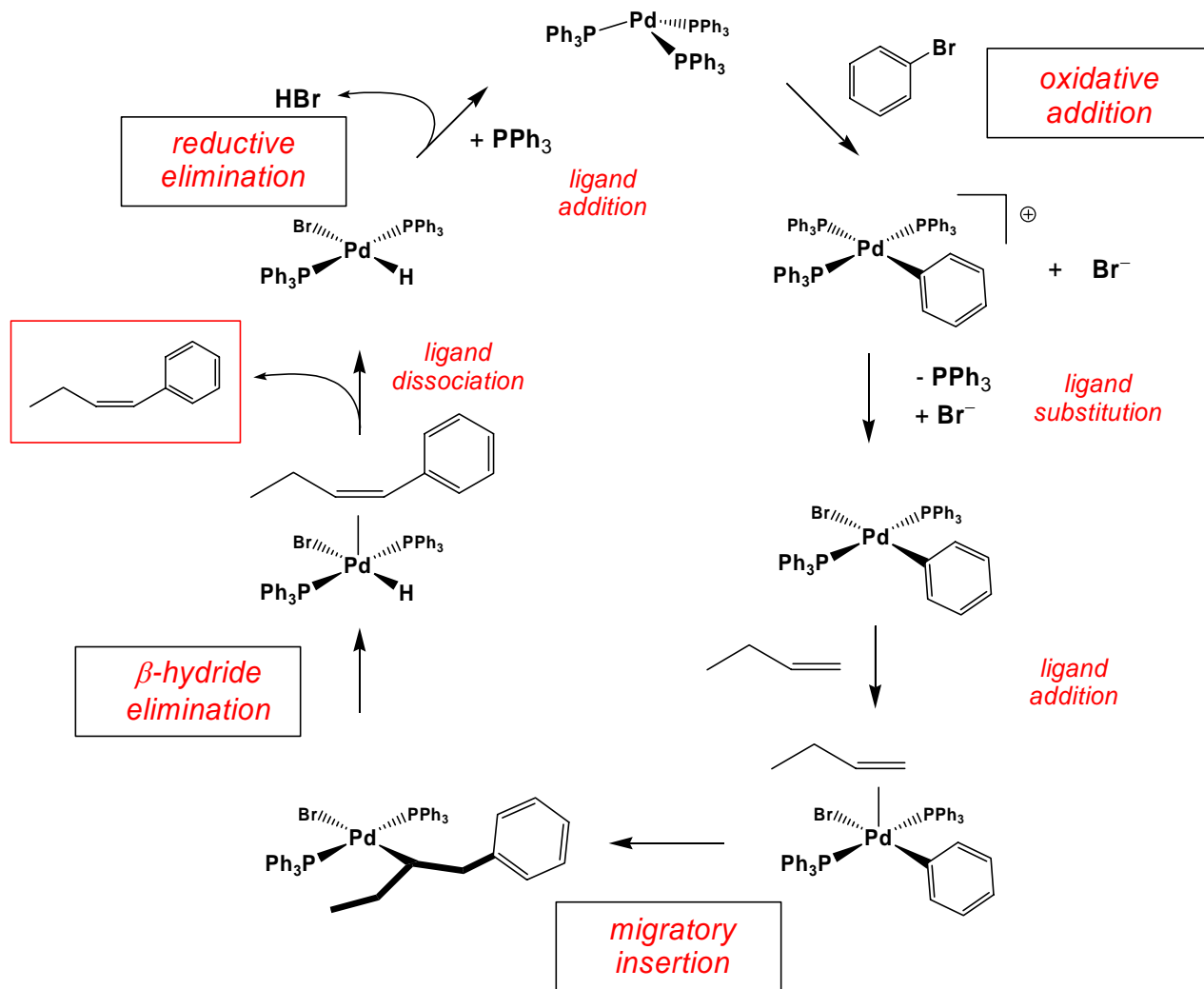

b) (10 pts) The bromide ligand substitution step on the right hand side could be either a dissociative substitution or an associative substitution. Make a short clear case for each possibility.

Associative Substitution:

The $[\text{Pd}(\text{Ph})(\text{PPh}_3)_3]^+$ complex is 16e⁻ and can bind a fifth ligand as seen in the following step where the alkene binds to the empty axial coordination site. It is also cationic, which will attract the anionic bromide ligand. Once the Br⁻ binds, it will be quite favorable to kick off one of the sterically bulky and not very strongly bound PPh₃ ligands.

Dissociative Substitution:

Although the $[\text{Pd}(\text{Ph})(\text{PPh}_3)_3]^+$ complex is 16e⁻ and can bind a fifth ligand, one of the moderately bulky PPh₃ ligands that does not coordinate very strongly is very likely to dissociate to make a less sterically hindered 14e⁻ complex that can easily fit in the Br⁻ ligand. The three moderately bulky PPh₃ ligands are also likely to block the coordination of the Br⁻ ligand to the $[\text{Pd}(\text{Ph})(\text{PPh}_3)_3]^+$ complex via an associative substitution.

7. (20 points) Consider the following overall reaction:

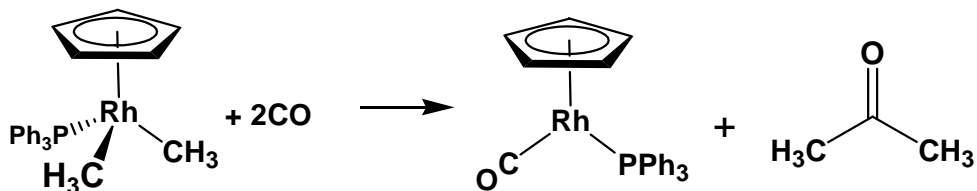

There are 5 steps to this reaction, with the last step being a simple ligand addition of PPh_3 to get to the Rh containing final product complex. **Clearly sketch out and label each step (one per line)**. For substitution reactions, indicate the overall reaction (not as separate ligand addition/dissociation rxns) and whether it is an associative or dissociative substitution. When this was asked in class as a quiz question, very few got it correct. Let's see if you do better now. To make your drawing simpler, you may use a simple oval as an abbreviation for the Cp ring.

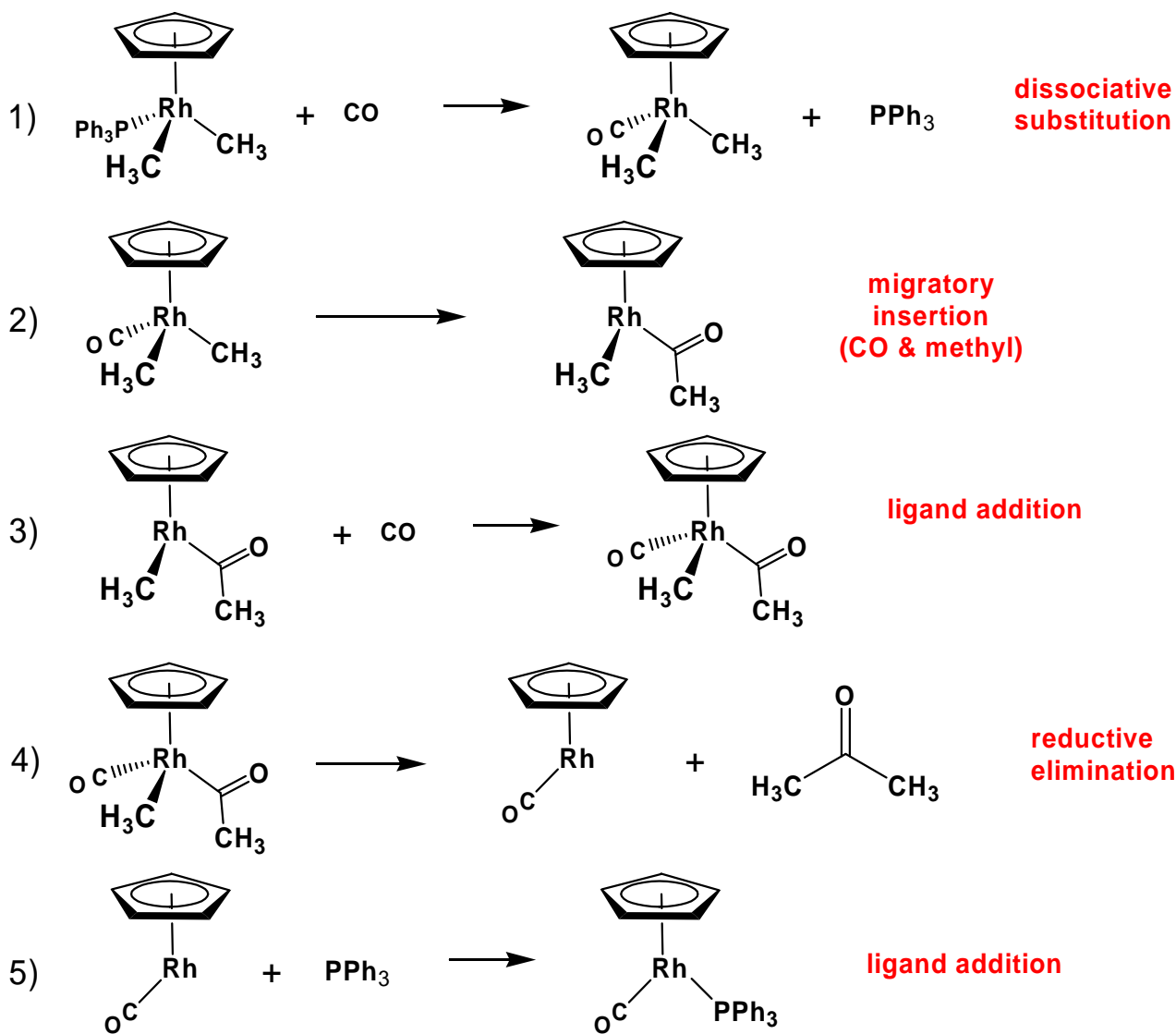

Check this box if you want your graded test put out in the public boxes outside Prof. Stanley's office:

1. (40 points) Classify the following reactions as oxidative addition, reductive elimination, migratory insertion, elimination, β -hydride elimination, ligand substitution, ligand dissociation, ligand addition, oxidative coupling, hydrogenolysis (i.e., 4-center concerted H_2 activation & transfer), etc. There may be more than one step and that the equations are not necessarily balanced or completely list all possible products. If there is more than one step to label, make sure you list the steps in the correct order *if* the order is important. NO discussion or justification is necessary.

The Mn is an 18e- d^6 center, so you must dissociate a ligand in order to do the H_2 oxidative addition

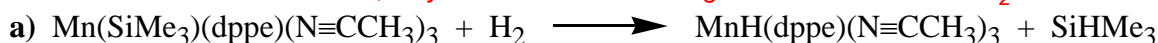

- 1) $N\equiv CCH_3$ ligand dissociation
 2) H_2 oxidative addition
 3) reductive elimination of $SiHMe_3$
 4) $N\equiv CCH_3$ ligand addition

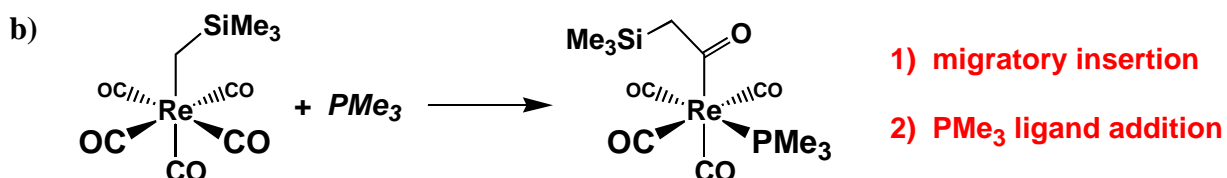

- 1) ligand dissociation (PMe_3) 2) H_2 oxidative addition

(The Zr(+2) is an 18e- d^2 center and can do an oxidative addition with H_2 , but not until you dissociate one of the PMe_3 ligands to generate an empty orbital on the Zr so the H_2 can coordinate.)

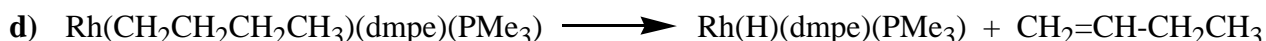

- 1) elimination (β -hydride elimination) 2) alkene ligand dissociation

(one could also initially dissociate the PMe_3 ligand, do the β -hydride elimination, dissociate the alkene, then recoordinate the PMe_3)



- 1) migratory insertion (carbene & Ph^- group) 2) PMe_3 ligand addition

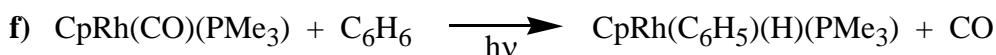

- 1) CO (or PMe_3) ligand dissociation 2) oxidative addition of benzene C-H bond

(order is important, you must first have a ligand dissociate to make an unsaturated 16e- center that the benzene C-H bond can coordinate to in order to initiate the oxidative addition)

2. (20 pts) For each of the following pairs of metal complexes, circle the one that will *most readily* do an **oxidative addition** to the substrate shown. No discussion is necessary.

- a) CH_3I : $\text{RhCl}(\text{CO})_3$ - or - $\text{IrH}(\text{CO})(\text{PMe}_3)_2$ *this is the most e- rich complex*
- b) CH_3I : $\text{Rh}(\text{I})(\text{CO})\{\text{P}(\text{tert-butyl})_3\}_2$ - or - $[\text{Re}(\text{CO})_3(\text{dmpe})]^-$ *the P(tert-butyl)₃ is too bulky*
- c) H_2 : $\text{Cp}_2\text{Nb}(\text{NMe})(\text{CH}_3)$ - or - $[\text{Rh}(\text{CO})_2\text{I}_2]^-$ *the Nb complex is d⁰ and can't do an oxidative addition*
- d) Cl_2 : $\text{Mo}(\text{CO})_3\{\text{P}(\text{OMe})_3\}_3$ - or - $\text{Mo}(\text{CO})_3(\text{PMe}_3)_3$ *this is the most e- rich complex*

3. (30 pts) Use the boxes to label the following steps to identify what is going on in the following catalytic cycle (see choices listed from problem #1).

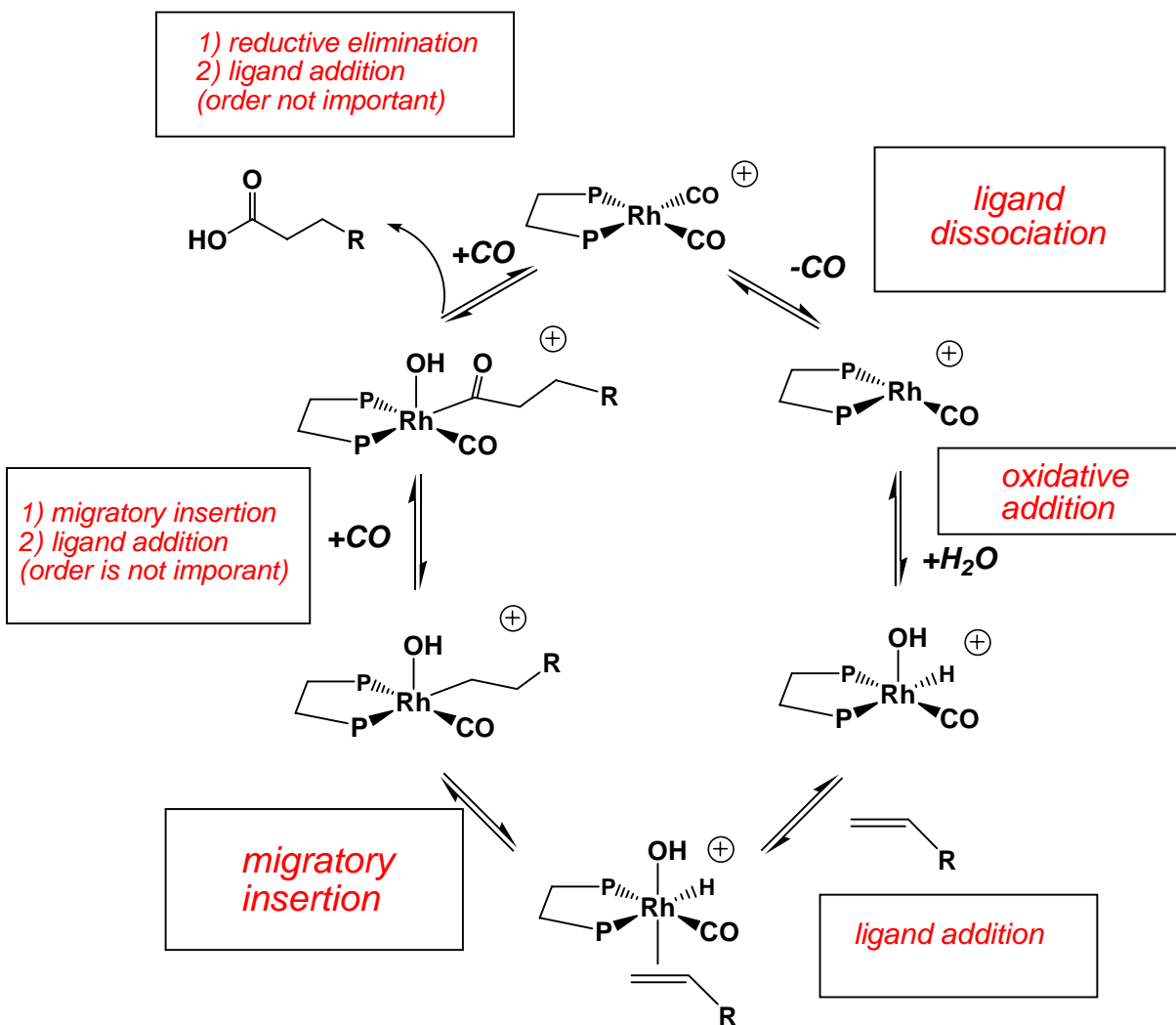

4. (20 points) a) (10 pts) Explain how the methyl and bromide ligands in the following reaction end up in the indicated positions. Use diagrams to clearly illustrate your vivid description of this process.

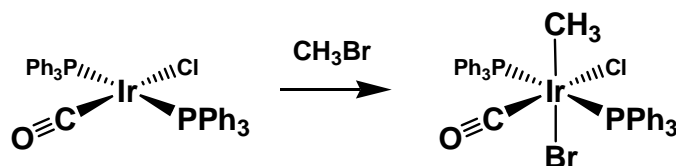

The 16e- Ir(+1) d^8 metal center is e- rich enough to perform an S_N2 type nucleophilic substitution on the electrophilic carbon of the CH_3I . This is an **oxidative addition** type reaction that kicks off an anionic I- ligand and generates the Ir(+3) 16e- cationic fragment. The I- anion can diffuse through the solution to bind to the empty cationic coordination site to make the trans-product.

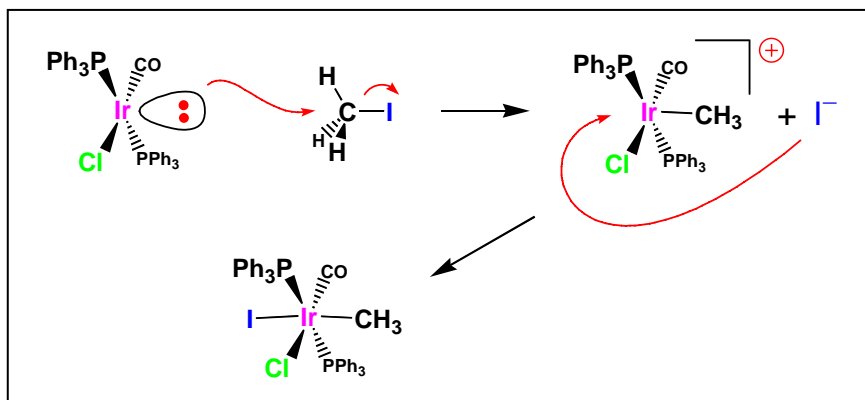

- b) (10 pts) The reaction of $IrCl(CO)(PPh_3)_2$ with H_2 gives the *cis*-dihydride $IrH_2Cl(CO)(PPh_3)_2$. Explain why this is different from part a) above.

In the H_2 case, the less electrophilic and reactive H_2 needs to precoordinate to the empty p_z orbital on the Ir. Then the oxidative addition occurs in a more or less concerted fashion to give the *cis*oidal dihydride. The main difference is that this is not proceeding by the S_N2 type reaction shown above.

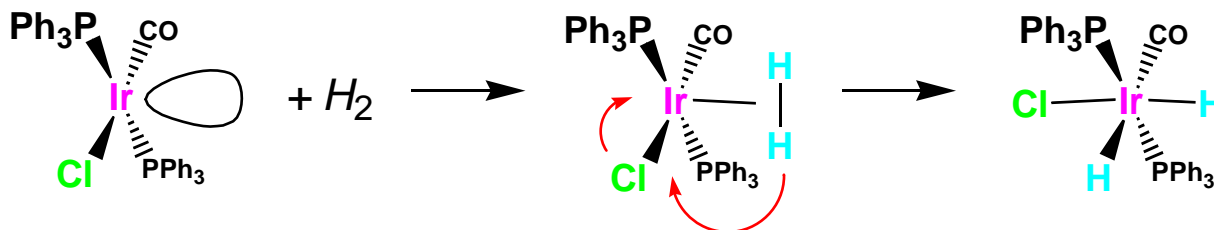

5. (10 pts) $Mo(CO)_3(PMe_3)_3$ is extremely **inert**, while $Mo(CO)_2\{P(OMe)_3\}_3(CH_3)$ is **quite reactive and easily substituted**. Briefly discuss the reasons for these differences.

$Mo(CO)_2\{P(OMe)_3\}_3(CH_3)$ is a Mo(+1), d^5 , 17e- complex with poorly donating $P(OMe)_3$ ligands, while the $Mo(CO)_3(PMe_3)_3$ complex is Mo(0), d^6 , 18e- electron-rich complex with strongly donating PMe_3 ligands and strongly π -backbonding CO ligands. The not very electron-rich 17e- complex has more weakly coordinated ligands that can more easily dissociate, but it can also perform an associative substitution due to its 17e- count, proceeding via the 19e- intermediate. The electron-rich 18e- system has very strongly bonded ligands that can not dissociate at all easily.

6. (30 pts) Consider the following reaction that produces neopentane:

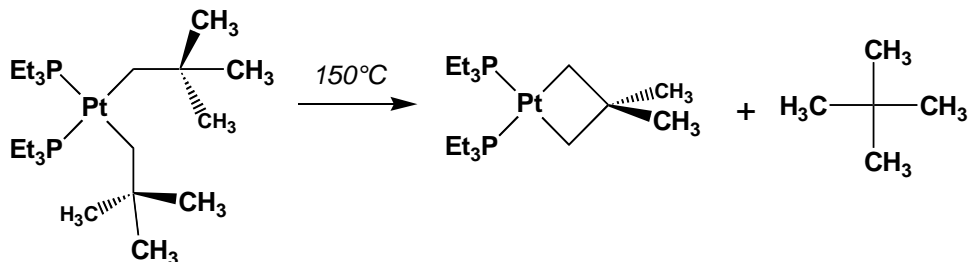

a) (20 pts) Sketch out a detailed mechanism based on the following steps: 1) ligand dissociation, 2) C-H oxidative addition, 3) reductive elimination of neopentane product, 4) ligand addition. The starting complex is shown below. Please use organic line notation for your *tert*-butyl groups (as shown below). Clearly draw your structures.

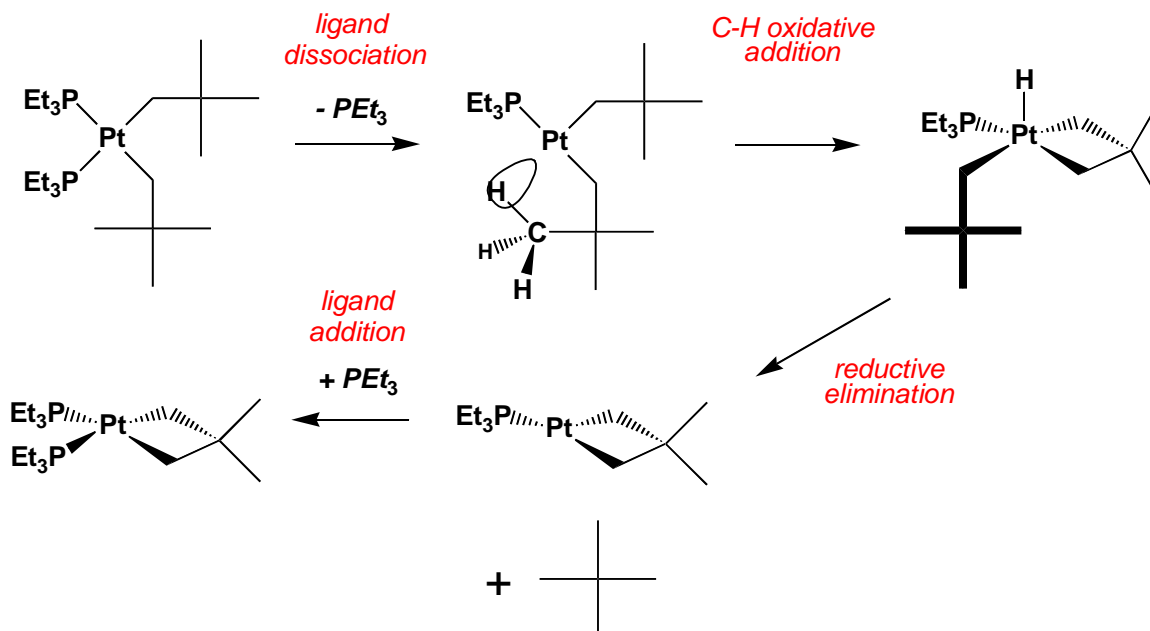

b) (5 pts) Is the geometry about the Pt center in the product closer to square planar or tetrahedral? Briefly discuss.

Square Planar. Pt(+2) is d^8 and I've stated many times in class that Rh, Ir, Pd, and Pt d^8 metals love square planar geometries. It will not be perfectly square planar, however, due to the two cisoidal phosphines and the 4-membered metallocycle. But it is definitely not tetrahedral.

c) (5 pts) Why are the two alkyl groups in the starting Pt complex cisoidal when steric factors should favor a trans orientation?

The σ -trans electronic effect prefers to have stronger donating ligands, like an anionic alkyl, trans to a weaker coordinating ligand, like neutral PEt_3 . Steric effects can often override this kind of moderate electronic effect, but not in this case.

FINAL EXAM -- May 2004

Check this box if you want your graded test put out in the public boxes outside Prof. Stanley's office:

1. (50 pts) Shown below is a catalytic cycle for the oxidation of ethylene to make acetaldehyde. This is a famous commercial reaction called the Wacker process.

a) (35 pts) Label the reaction steps indicated in the boxes provided. There may be more than one step per box (but not more than 2). Possible reaction step descriptions include (but are not limited to): migratory insertion, elimination, β -hydride elimination, oxidative addition, reductive elimination, substitution (associative or dissociative), ligand addition, ligand coordination (hapticity) change, hydrogenolysis, deprotonation, protonation, nucleophilic attack, electrophilic attack, etc.

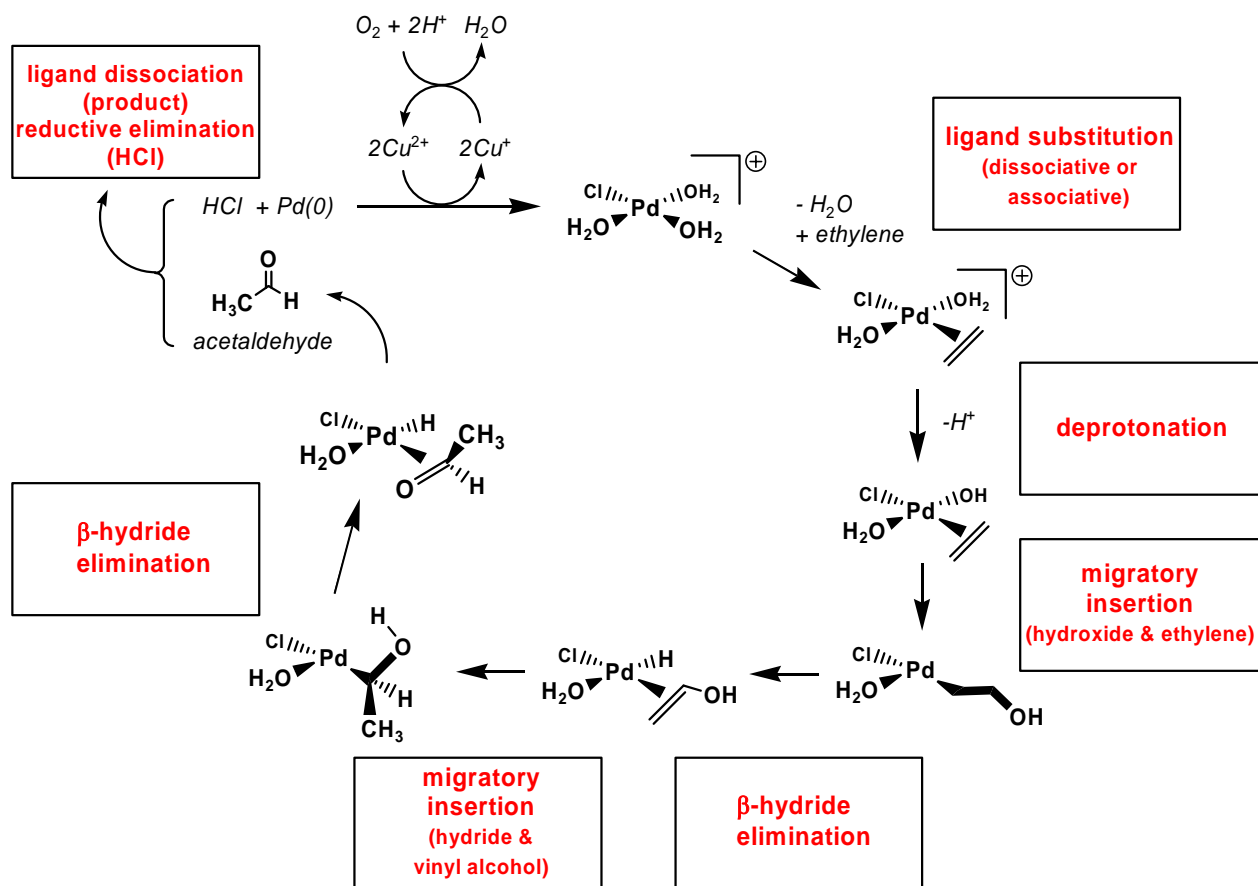

b) (5 pts) O_2 does not directly react with $\text{Pd}(0)$ to oxidize it to $\text{Pd}(+2)$. Based on this fact, briefly and clearly explain what is happening in the conversion of $\text{Pd}(0)$ to the $[\text{PdCl}(\text{H}_2\text{O})_3]^+$ complex at the top of the catalytic cycle.

$2\text{Cu}(+2)$ centers oxidize $\text{Pd}(0)$ back to the active starting $\text{Pd}(+2)$ catalyst complex, making two reduced $\text{Cu}(+1)$ centers. O_2 does directly react with and oxidize $\text{Cu}(+1)$ back to $\text{Cu}(+2)$. The reduced $\text{O}(-2)$ reacts with the two H^+ produced in the catalytic cycle to make H_2O . The $\text{Cu}(+2/+1)$ and O_2 , therefore, act as an oxidation catalyst system for transforming $\text{Pd}(0)$ back to $\text{Pd}(+2)$.

c) (5 pts) I didn't balance the $O_2/H^+/Cu(+,+2)$ mini-cycle properly as it should really have been $\frac{1}{2}O_2$. The question here concerns the $2H^+$ that are balanced correctly. Where do the $2H^+$ come from? Is the catalytic reaction doing a net consumption of H^+ causing a solution pH change?

The first H^+ comes from the deprotonation step on the right-hand side of the catalytic cycle. The second H^+ comes from the reductive elimination of HCl , which is a strong acid. Because two H^+ 's are produced in the catalytic cycle, there is no net consumption of H^+ , so the pH of the solution should stay the same overall.

d) (5 pts) Why is the step that generates the neutral $PdCl(OH)(H_2O)(CH_2=CH_2)$ complex important?

The deprotonation of the water (right-hand side of the catalytic cycle) is promoted by the cationic charge on the Pd center. This is important to generate the hydroxide anionic ligand that is far more reactive for doing a migratory insertion with the ethylene. Remember that most migratory insertions require a neutral ligand (typically with a π -system) and a nucleophilic anionic ligand. These react together to make a new anionic ligand coordinated to the metal center. Neutral water and ethylene would find it very difficult to react together.

2. (50 pts) Consider the following reaction called hydrovinylation from homework # 4:

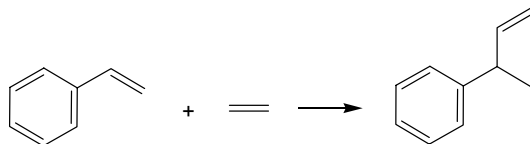

Clearly sketch out the catalytic cycle starting with $NiHCl(PCy_3)$ (shown below) with reasonably accurate structures based on the indicated sequence of steps:

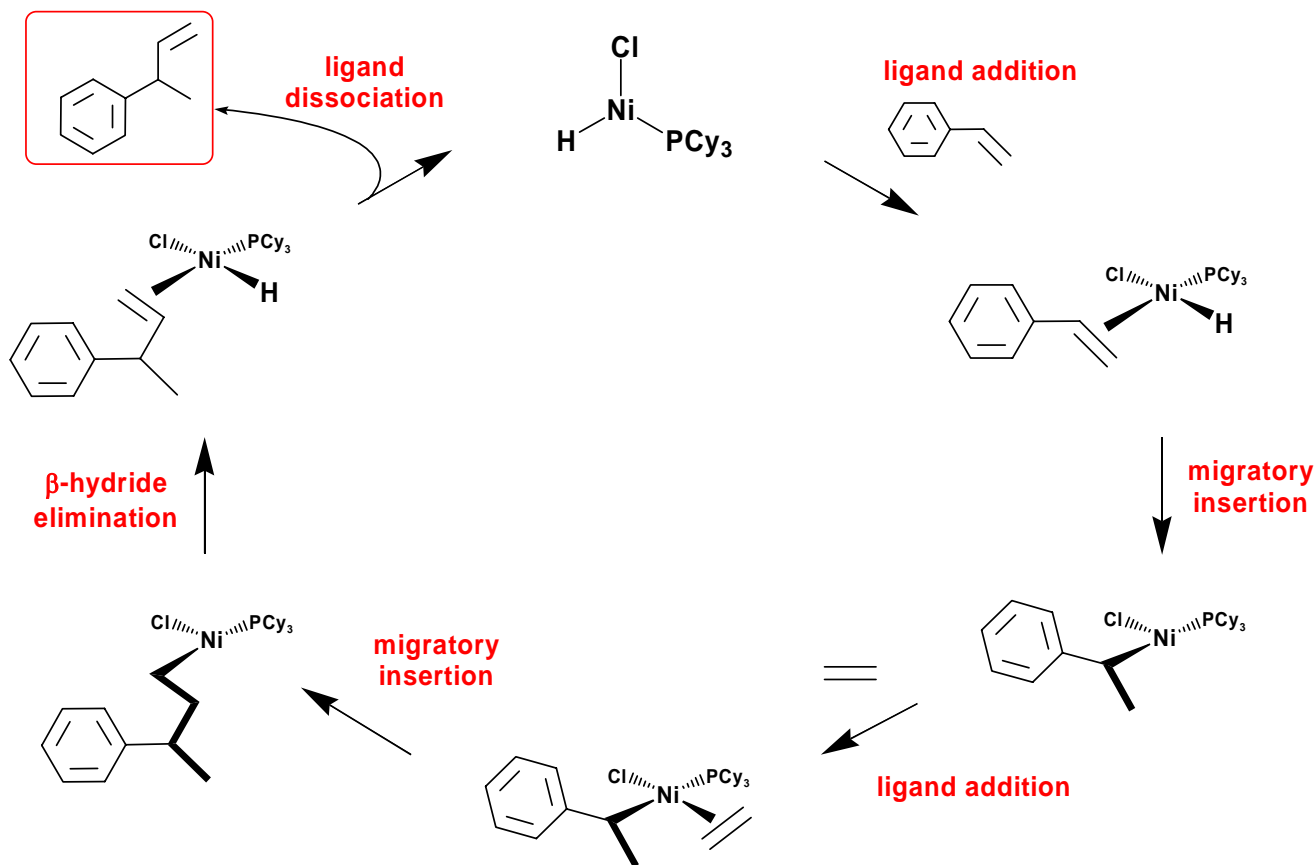

3. (50 pts) The cyclotrimerization of acetylene ($\text{H-C}\equiv\text{C-H}$) to benzene (shown below) is catalyzed by many metal complexes.

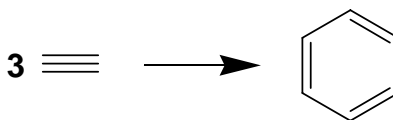

- a) (30 pts) Sketch out and label the steps for a catalytic cycle for this starting with the Ni complex shown below (*Hint: first step is oxidative coupling*).

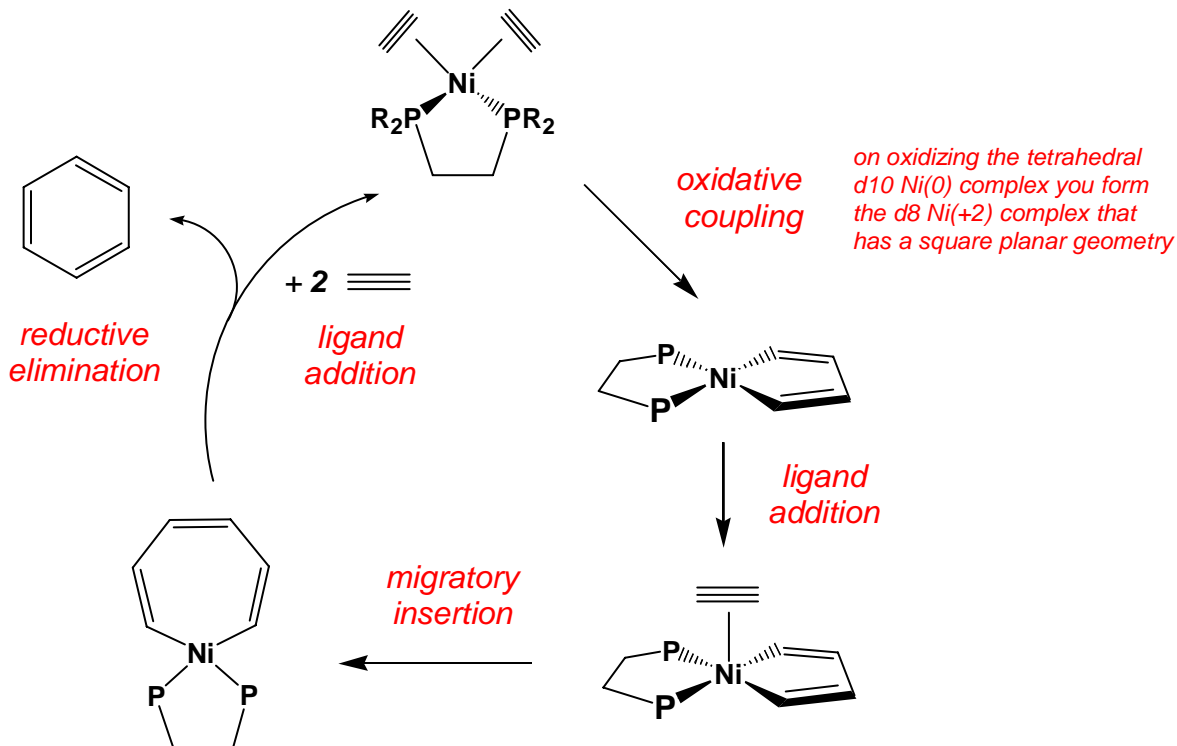

- b) (10 pts) Small alkylated phosphines make this catalyst work better. Discuss reasons for this observation.

Alkylated phosphines are strong donor groups and will make the nickel more electron rich. This is good for the first step that involves an oxidative coupling of the two acetylenes. Oxidative reactions (additions or couplings) are helped by more electron rich metal centers. Theoretically, the more electron-rich metal should do the reductive elimination more slowly, but there is a considerable thermodynamic driving force for making benzene that compensates for this.

- c) (10 pts) From an electronic viewpoint, would you want to put electron-donating or electron-withdrawing groups on the alkyne to make the reaction go faster (don't worry about steric effects). Clearly discuss.

Electron-withdrawing groups on the alkyne will make them better electron acceptor groups and accelerate the initial oxidative coupling step. They might slow down the reductive elimination step by making it harder for the two cisoidal sigma-bound vinyl groups to give up one electron each to the metal center. But, once again, the thermodynamic driving force of the benzene formation should more than compensate for this. The initial oxidative coupling is probably more difficult than the final reductive elimination.

4. (50 pts) Sketch out a reasonable catalytic cycle for the hydrogenation of ethylene to ethane using $\text{RuCl}_2(\text{PR}_3)_3$ as the catalyst and a **hydrogenolysis-type mechanism** (no oxidative addition of H_2 to the metal center). Label each step in your cycle.

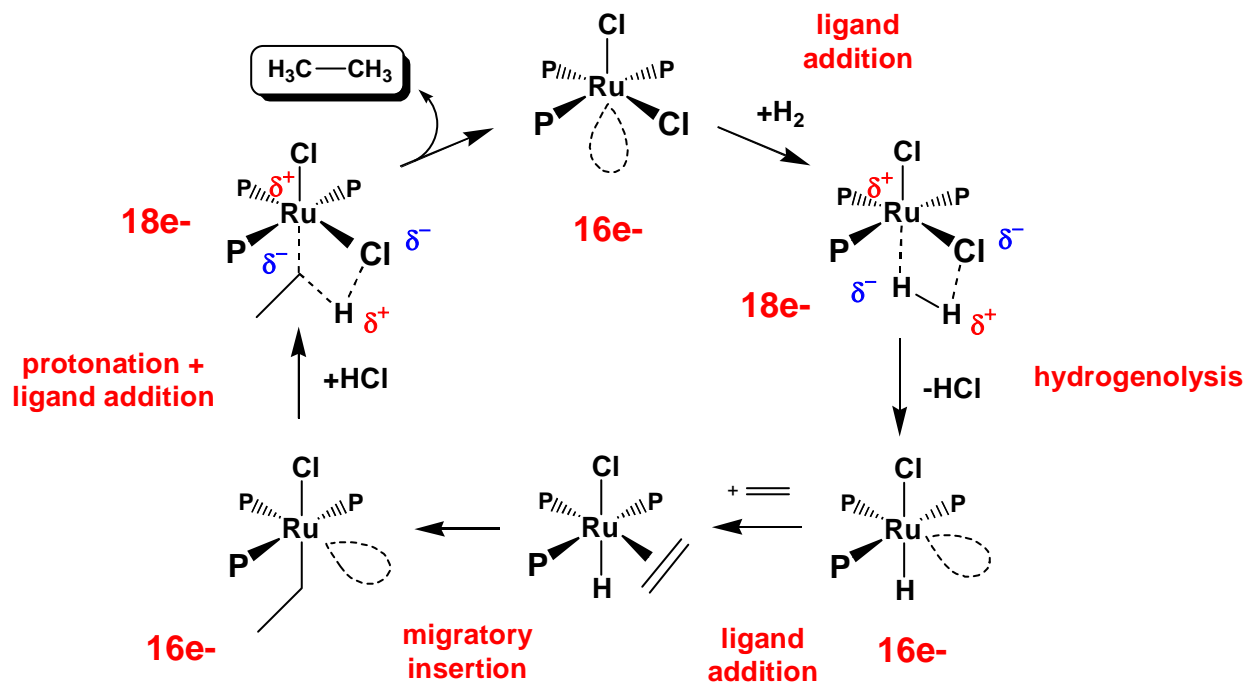

5. (50 pts) a) (30 pts) Label the steps in the following catalytic cycle:

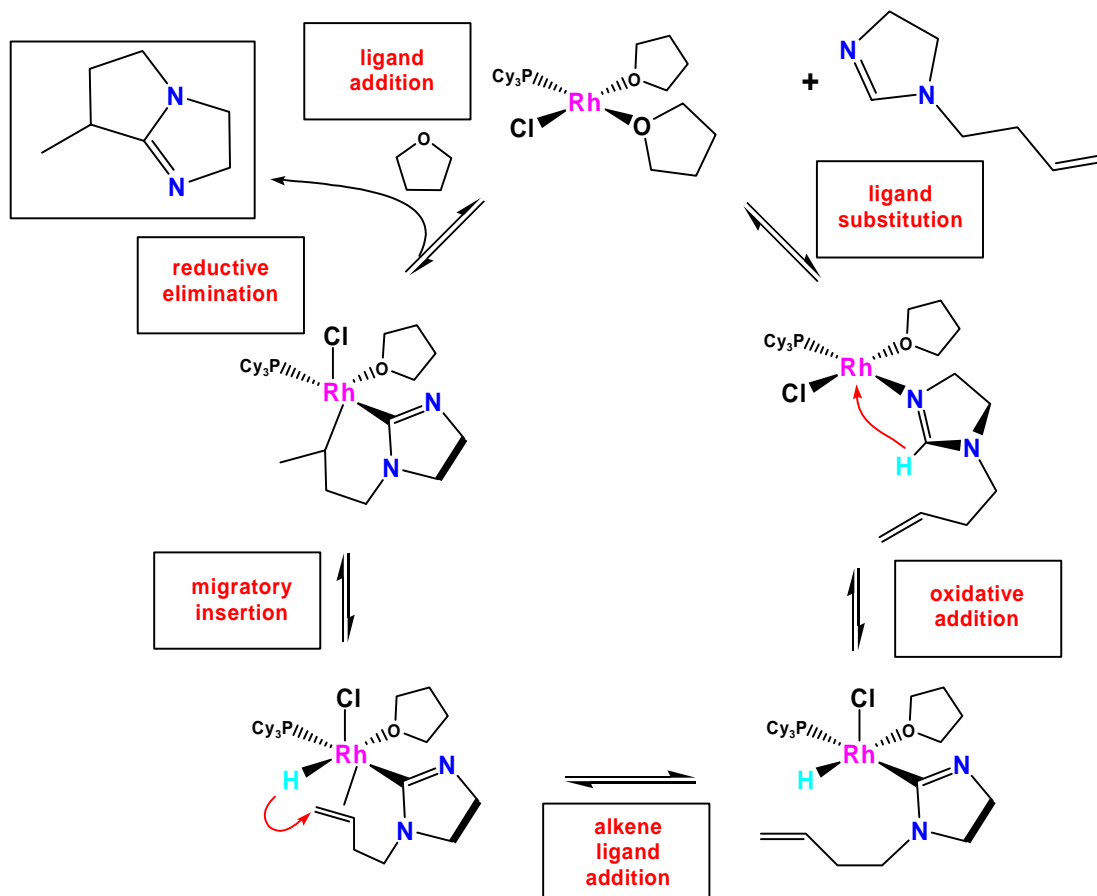

b) (5 pts) This catalytic reaction was run at 160-180°C with excess PCy₃, but I've only drawn the catalyst with one PCy₃ ligand. Why didn't I use two PCy₃ ligands on the catalyst?

Two PCy₃ ligands would make the catalyst way too sterically hindered to do this reaction. It is typical to add a little extra phosphine ligand to maintain at least one coordinated phosphine ligand which generates the active catalyst. At the rather high reaction temperature of 160-180 °C (fairly high for a homogeneous catalyst) there will be a fair bit of phosphine ligand dissociation, even for a strongly donating alkylated phosphine ligand like PCy₃. Adding some excess phosphine ligand will help push the equilibrium back towards the mono-phosphine Rh complex.

c) (10 pts) One of the side reaction in the catalytic cycle is alkene isomerization to make the following product:

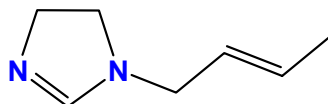

Write out the steps (with labels) showing how this happens starting with one of the complexes from the catalytic cycle.

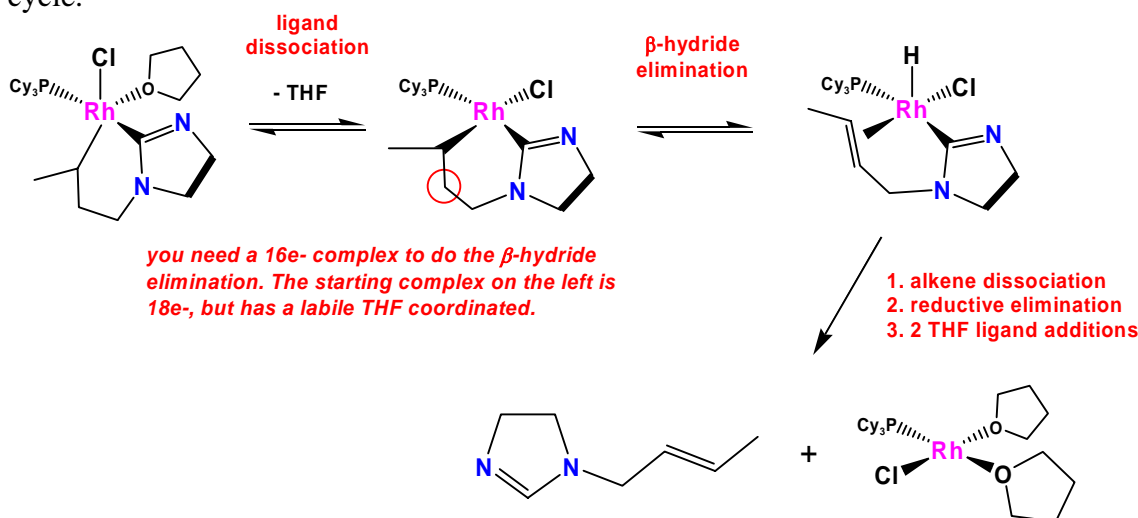

d) (5 pts) Would you expect the following substrate to do the analogous cyclization reaction shown in the catalytic cycle in part a)? Explain and assume that no alkene isomerization can occur.

No! The major problem with this substrate is that the ring closure step between the circled carbon of the alkene and the circled carbon of the existing ring will make a strained 4-membered ring. This is too high in energy to form readily.

An alkene isomerization to move the double bond out one more position would be OK and could possibly occur.

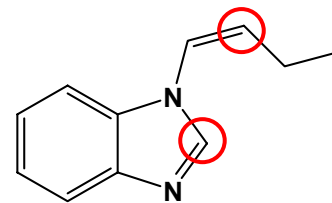

FINAL EXAM A -- May 2005

Check this box if you want your graded test put out in the public boxes outside Prof. Stanley's office:

1. (50 pts) Consider the following catalytic cycle for the Dupont dimerization of butadiene and ethylene (ethene) to produce 1,4-hexadiene.
- a) (30 pts) Label each step identified with a box and describe what is happening (note that there may be more than one choice per step as written – if so, make sure that you list the steps in the correct order). P = P(OR)₃ in the catalytic cycle. The step #'s are for part c).

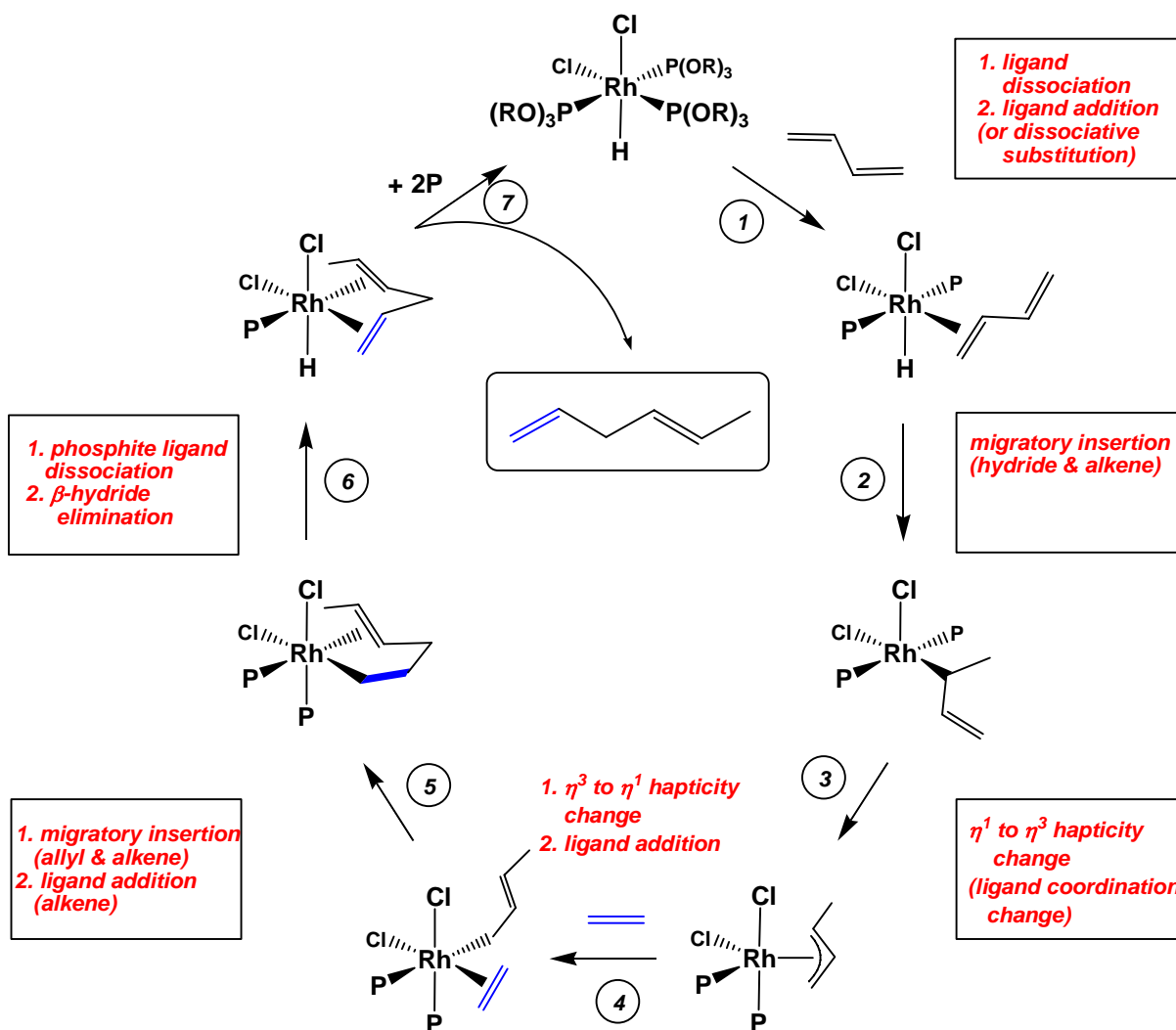

- b) (10 pts) The authors are using $P(OR)_3$ ligands for this reaction. What are the main advantages these offer for the catalytic cycle relative to PR_3 ligands (R = alkyl group, assume same cone angles).

Phosphite ligands typically are poor donors and medium π -acceptors. They generally have reasonably weak bonds to metal centers (unless there is a lot of π -backbonding) and can dissociate easily. The ability to dissociate is important for this catalytic cycle where open coordination sites need to be generated for the alkene ligand additions and final β -hydride elimination step. Alkylated phosphines are typically strong donors and do not dissociate easily. That would be bad for this catalytic cycle.

- c) (10 pts) All but one of the steps in the catalytic cycle shown on the previous page are readily reversible (in equilibrium). Which step will have considerable difficulty going backwards (i.e., counter-clockwise)? Identify by the step number. Clearly (and briefly) discuss why.

Step # 5 cannot easily go backwards. The formation of a saturated C-C bond is usually very difficult to reverse for kinetic reasons. Most C-C bonds are surrounded by C-H bonds that have more accessible orbitals for reacting with a metal center. This is true even though the C-H bond is typically stronger than a C-C bond. But the directed sp^3 hybrid orbitals that make up C-C single bonds are difficult for a metal center to access for orbital overlap in order to attempt a back elimination reaction (or oxidative addition).

2. (50 pts) $[PdX(CO)(bipy)]^+$ is an active catalyst (when X = H, CH_3) for the copolymerization of CO and ethylene to produce polyketones. **Key observations: This catalyst produces only perfectly alternating CO and ethylene (ethane links) groups in the polyketone product (no CO-CO links or $(CH_2)_{3,4}$ groupings). No aldehyde end groups are observed.**

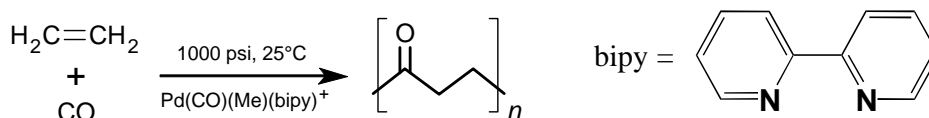

- a) (30 pts) Sketch out the mechanism for polymerizing 2 CO and 2 ethylene molecules (don't draw it as a cycle). Use $[Pd(CH_3)(CO)(bipy)]^+$ as your starting catalyst (shown below, you can abbreviate the bipy ligand as two N's linked by a curved line). **Label each step of the reaction.** Your mechanism must account for the observations noted above.

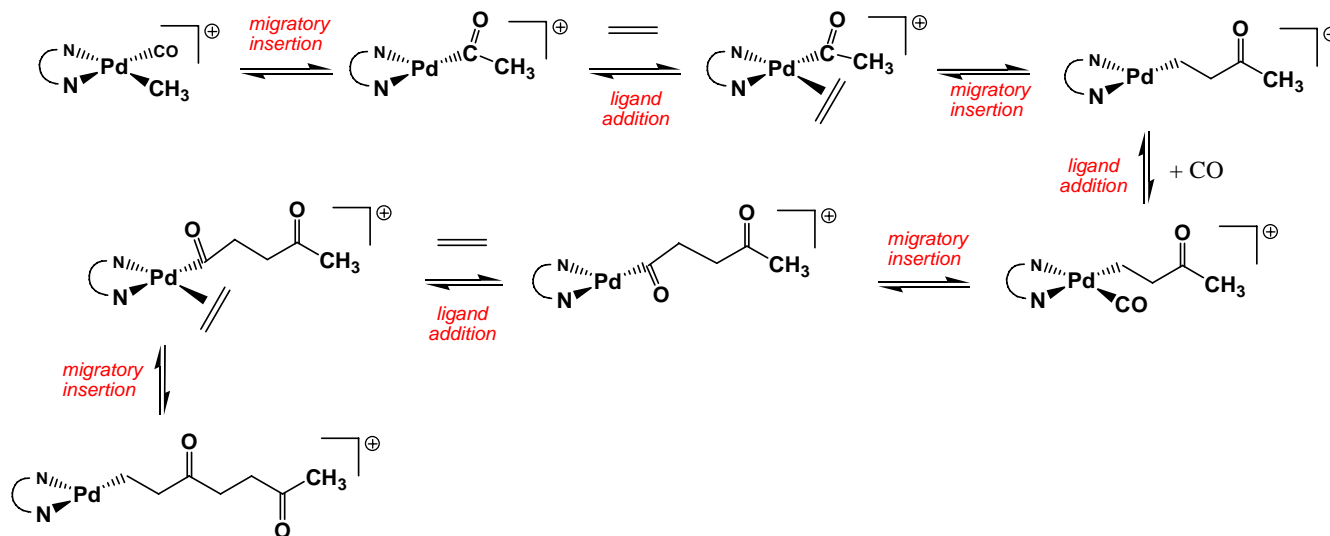

- b) (10 pts) The overall cationic charge on the Pd center is important for this catalysis for two main reasons. It promotes a key reaction step and it inhibits (reduces) a side reaction with CO that can dramatically reduce the activity of the catalyst. Briefly and clearly describe these and how the positive charge helps the catalysis.

The cationic charge makes the metal center somewhat more electron deficient. This promotes migratory insertions that are very important for this polymerization reaction. It also makes coordination of the alkene a little more favorable by making the metal a little more electrophilic.

The cationic charge reduces strong coordination by CO that can block open coordination sites by making stable 18e- 5-coordinate complexes. The more electron deficient a metal center is the weaker CO will coordinate (less π -backbonding).

- c) (10 pts) When the hydride complex $[\text{PdH}(\text{CO})(\text{bipy})]^+$ is the starting catalyst what is the first step in the chain growth process? Note that your answer must be consistent with the observations noted in the first part of the question.

If one is starting with a Pd-H complex, the first migratory insertion has to be with ethylene and not CO. This is opposite what happens when one starts with a Pd-CH₃ (alkyl) complex where the first migratory insertion step is with CO.

Migratory insertions of CO and H are usually not favored thermodynamically. CO migratory insertions into M-acyl bonds are also unfavorable. Ethylene-alkyl migratory insertions are typically more difficult than CO-alkyl migratory insertions. These all work together so the catalyst has built-in self-correcting features to keep the CO and ethylene migratory insertions perfectly alternating.

3. (50 pts) One of the problems with late transition metal catalysts for ethylene polymerization is that they like to do β -hydride eliminations and are subject to a problem called “associative displacement” that cuts short the chain growing process.

- a) (15 pts) Sketch out a mechanism for this starting with the following complex that undergoes the following steps: 1) β -hydride elimination, 2) ethylene addition, 3) ligand dissociation. You can abbreviate the bis-imine ligand as shown in problem 2 for bipy, i.e., two N atoms connected by a curved line.

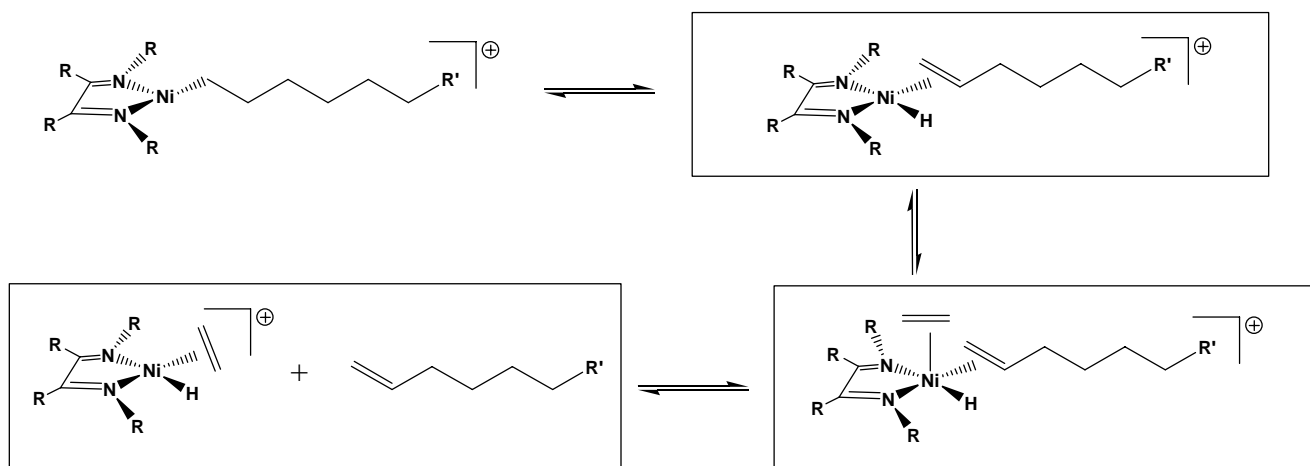

b) (25 pts) Prof. Maurice Brookhart used large bulky R groups on the bis-imine ligand designed to block the axial coordination sites on the d^8 metal center that prevented the associative displacement problem, but still allowed ligand coordination in the square plane (structure to right). This resulted in the first extremely good ethylene polymerization catalysts for Ni or Pd. These catalysts, however, have the unusual ability to make highly branched polyethylene via β -hydride eliminations coupled with migratory insertions – a process called “chain walking.” Shown below are the first several steps in a chain-walking isomerization that makes an ethyl branch in the polymer chain (note that I stop showing the alkyl/alkene group rotations after the first few). Complete the missing boxed structures. You can abbreviate the bis-imine ligand as done previously, i.e., two N atoms connected by a curved line.

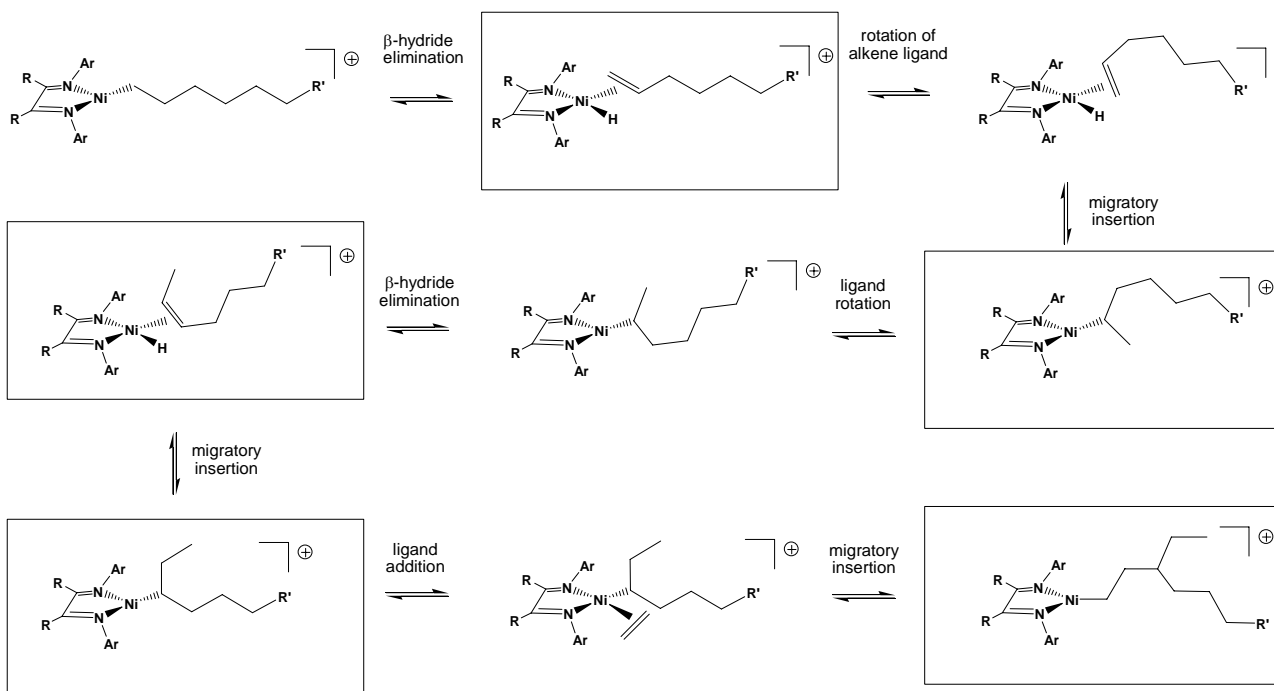
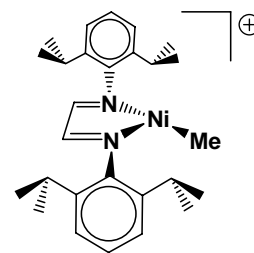

c) (10 pts) Increasing the ethylene pressure used in the catalysis reduces the amount of branching in the polyethylene produced. Why?

Increasing the ethylene pressure increases the concentration of ethylene in solution. This increases the probability of it coordinating with the catalyst, which will “short-circuit” the polymer alkyl chain from β -hydride eliminating and doing the chain-walking isomerization. See the last step in the chain-walking mechanism above.

4. (50 pts) Sketch out a catalytic cycle for the following reaction using the starting catalyst complex shown below. Clearly label and identify each step.

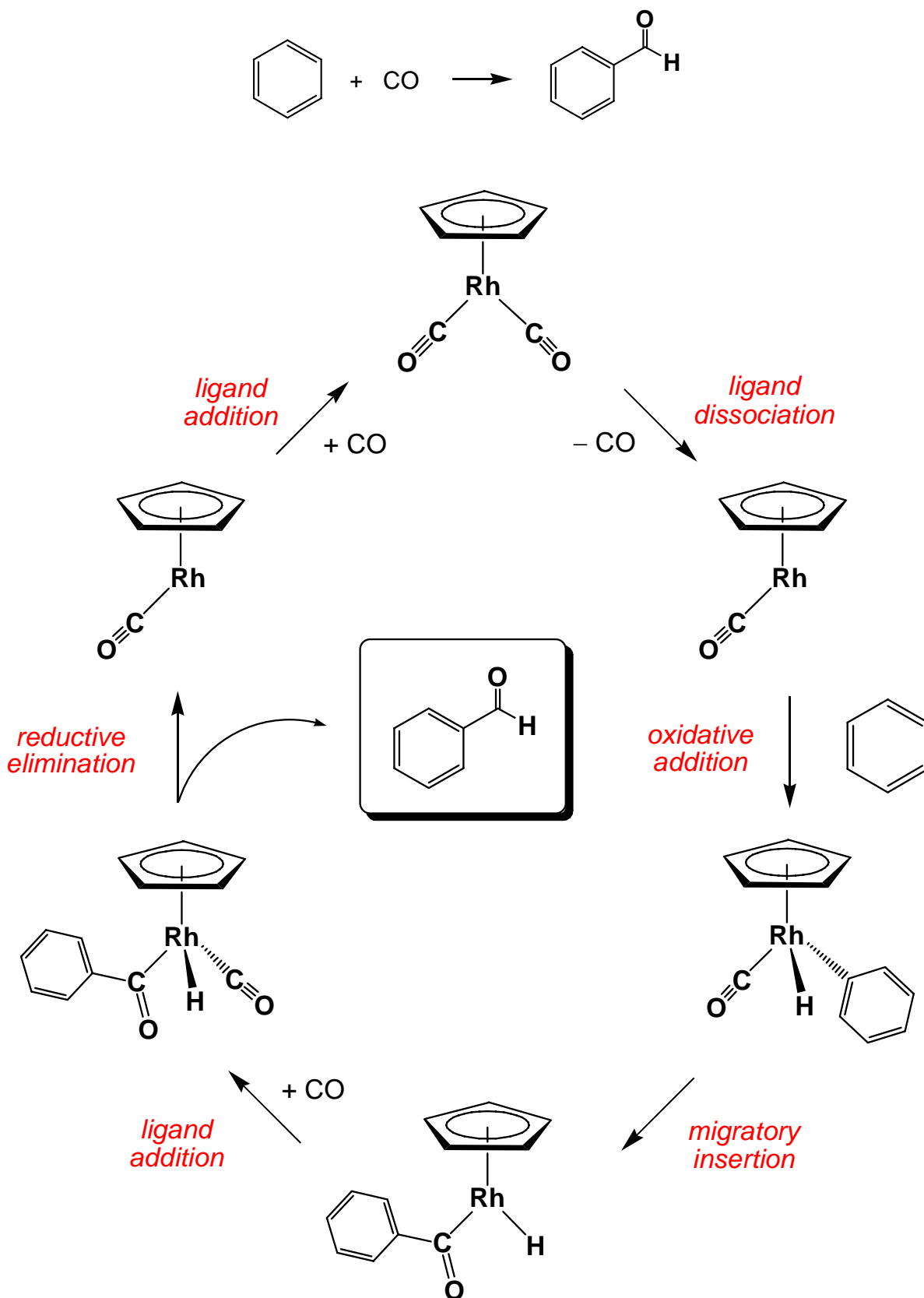

5. (50 pts) Shown below is the isomerization of 1-butene proceeding by the “allylic” mechanism.

a) (20 pts) label the steps with the boxes. If there is more than one step occurring, put them in the correct order if the order is important.

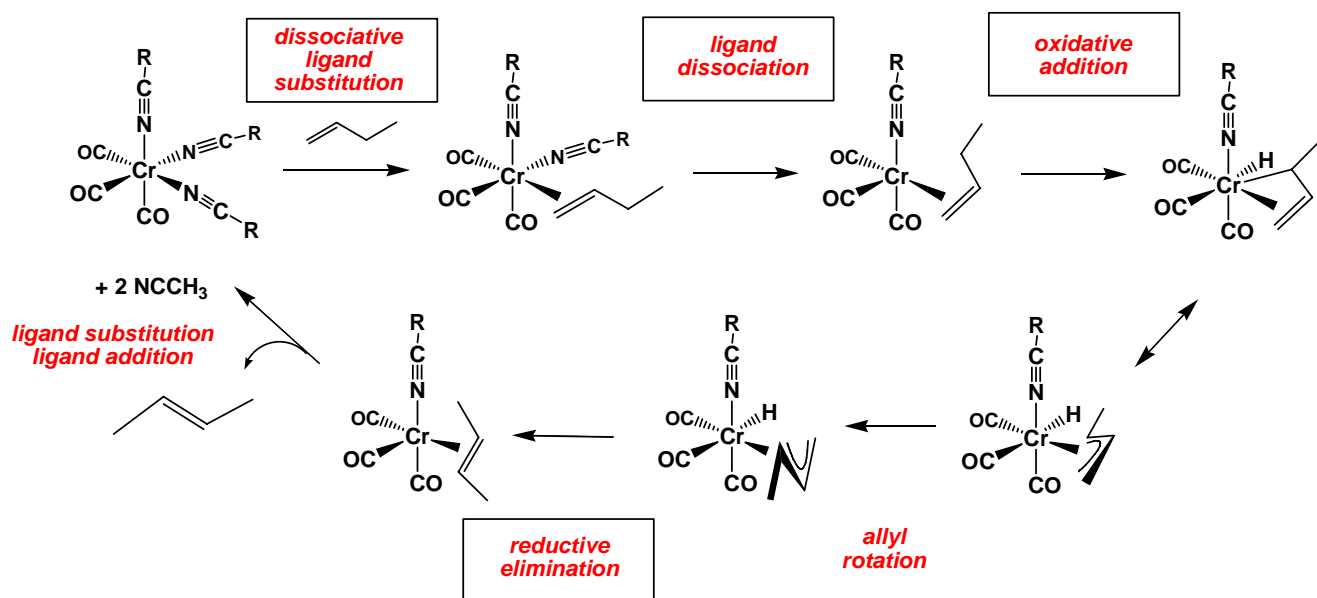

b) (10 pts) Why is it important for the allyl ligand to “rotate” in the step above.

The allyl ligand needs to rotate about 180° so that when the hydride does the reductive elimination to go back to the alkene it has “moved” the double bond to the internal position of the carbon chain. This is a key part of the isomerization process.

c) (20 pts) Sketch out a mechanism for the isomerization of 1-butene via the “hydride” mechanism starting with $\text{HRh}(\text{dmpe})(\text{N}\equiv\text{C}-\text{R})$. Clearly label each step.

