

Orion TableTop Telescopes

#10022 StarMax™ 90 TableTop Maksutov-Cassegrain

#10012 SkyScanner™ 100 TableTop Reflector

#10013 GoScope™ 80 TableTop Refractor

Français

① Pour obtenir le manuel d'utilisation complet, veuillez vous rendre sur le site Web OrionTelescopes.eu/fr et saisir la référence du produit dans la barre de recherche.



② Cliquez ensuite sur le lien du manuel d'utilisation du produit sur la page de description du produit.



Deutsche

① Wenn Sie das vollständige Handbuch einsehen möchten, wechseln Sie zu OrionTelescopes.de, und geben Sie in der Suchleiste die Artikelnummer der Orion-Kamera ein.

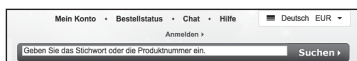

② Klicken Sie anschließend auf der Seite mit den Produktdetails auf den Link des entsprechenden Produkthandbuchs.



Español

① Para ver el manual completo, visite OrionTelescopes.eu y escriba el número de artículo del producto en la barra de búsqueda.



② A continuación, haga clic en el enlace al manual del producto de la página de detalle del producto.



#10013



#10012



#10022



Corporate Offices: 89 Hangar Way, Watsonville CA 95076 - USA
 Toll Free USA & Canada: (800) 447-1001
 International: +1(831) 763-7000
 Customer Support: support@telescope.com

Copyright © 2020 Orion Telescopes & Binoculars. All Rights Reserved. No part of this product instruction or any of its contents may be reproduced, copied, modified or adapted, without the prior written consent of Orion Telescopes & Binoculars.

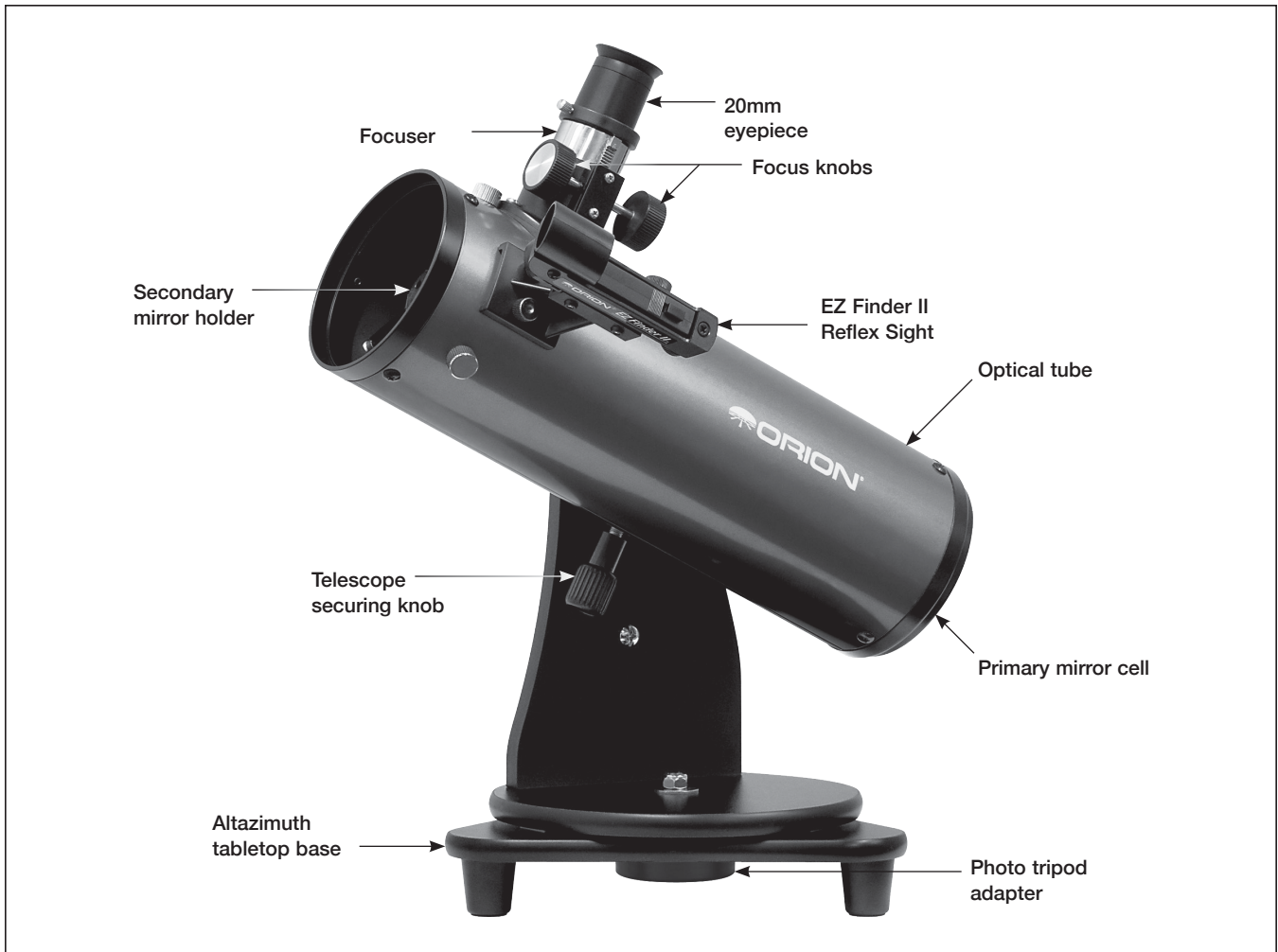

Figure 1a: The SkyScanner 100 TableTop Telescope

Congratulations on your purchase of a TableTop telescope. The TableTop will provide years of enjoyment of many night-sky treasures including breathtaking views of the Moon, planets, and even some bright deep sky objects. The Maksutov-Cassegrain and refractor models are also suitable for exploring terrestrial vistas.

Your new TableTop is easy to setup and use. It will arrive almost fully assembled out of the box! Only the visual accessories need to be installed. These include the EZ Finder II Reflex Sight, the eyepiece, and in the case of the GoScope 80 and StarMax 90, the diagonal.

The following instructions will help you to get the maximum performance from your new telescope, please read them thoroughly.

TableTop Parts (refer to Figure 1a-d):

All TableTop Models:

25mm (20mm for #9541 and #9549) eyepiece: The eyepiece is the part of the telescope that you actually look through to see things. The focal length of the eyepiece and the telescope determines the magnifying power. Magnification is discussed in more detail in the **Using Your Telescope** section

10mm eyepiece: The higher-power eyepiece that comes with the TableTop. Eyepieces are discussed in the **Magnification** section.

EZ Finder II reflex sight: This is a special “finder” that helps you aim the telescope and locate objects in the sky for viewing. The EZ Finder II generates a red LED “dot” that shows where your telescope is aimed. The use of the EZ Finder II is discussed in the **Getting Started** section.

Optical tube: This is the main component of the telescope.



Figure 1b: The StarMax 90 TableTop Telescope

Altitude tension adjustment knob: By tightening and loosening this knob, you can change the amount tension in the altitude (up/down) motion of the telescope.

Altazimuth base: This wooden base provides a stable base for the telescope. It allows you to move the telescope in altitude (up/down) and azimuth (left/right).

Photo Tripod Adapter: This allows you to attach your TableTop base to an optional photo tripod. It has a 3/8" female thread and a pre-installed 1/4"-20 adapter to fit virtually all photo tripods.

Rubber feet: Three feet provide support for the TableTop and are skid free. This allows you to place the TableTop on smooth surfaces.

Focus Wheels: The focus wheels are used to bring objects into focus. By turning them, you move the rack-and-pinion focuser in and out.

Eyepiece securing thumbscrews: These thumbscrews are used to keep the eyepiece secure in the focuser.

SkyScanner 100 TableTop:

Primary Mirror: The mirror at the rear of the optical tube gathers incoming light and focuses it with its parabolic shape.

Secondary Mirror: The secondary mirror is located near the opening of the optical tube and reflects the focused light from the primary mirror into the eyepiece.

Focuser: This is where the eyepiece is inserted, and how sharpness is adjusted. Details of the focuser are shown in Figure 8.

StarMax 90 TableTop:

Corrector plate: The lens at the front end of the optical tube designed to correct the aberration inherent in the design of the spherical primary mirror.

Primary Mirror: The spherical mirror at the rear of the optical tube gathers incoming light and reflects it.



Figure 1c: The GoScope 80 TableTop Telescope

Secondary Mirror: The secondary mirror is mounted on the corrector plate and reflects the focused light from the primary mirror into the eyepiece.

Focus Knob: This knob makes an internal adjustment to the optics to adjust the sharpness of the image

Dovetail Holder: Secures the telescope into the mini-Dob style mount by holding the dovetail bar preinstalled on the telescope tube.

90° Star Diagonal: An adapter used on refractor and catadioptric telescopes that positions the eyepiece to a more comfortable viewing angle and provides a right side up image.

GoScope 80 TableTop:

Objective Lens: The glass lens or lens system at the front end of the optical tube. This is the light-gathering source for the telescope.

Focus Knob: This knob makes an internal adjustment to the optics to adjust the sharpness of the image.

Dovetail Holder: Secures the telescope into the mini-Dob style mount by holding the dovetail bar preinstalled on the telescope tube.

90° Star Diagonal: An adapter used on refractor and catadioptric telescopes that positions the eyepiece to a more comfortable viewing angle and provides a right side up image.

Assembly

Assembly of the TableTop is very easy. Carefully remove the protective packaging. Your TableTop arrives from the factory with the optical tube attached to the base – just install the visual accessories and you will be ready to start viewing with your new telescope! These accessories will be found in a box within the main box. Please save all original packaging. This will help protect your TableTop if you wish to transport it or in the unlikely event repair service is necessary.

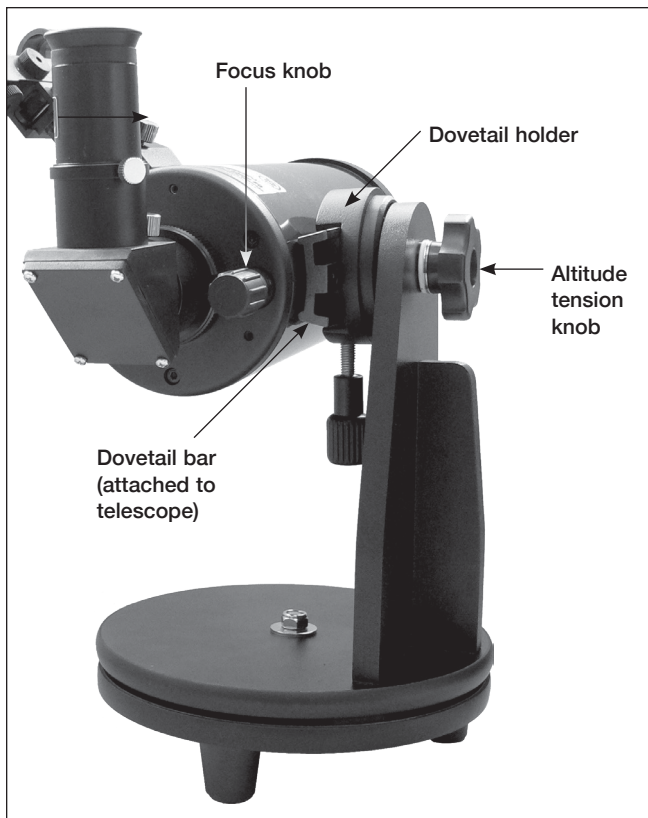

Figure 1d: Rear and side view of the TableTop Telescope (90mm model shown)

Parts List

- 1 EZ Finder II reflex sight with bracket
- 1 25mm eyepiece (90mm model)
- 1 20mm eyepiece (80mm & 100mm models)
- 1 10mm eyepiece
- 1 Diagonal (Refractor and Maksutov-Cassegrain models only)

When unpacking the telescope it is suggested that you save the internal packaging. In the unlikely event the product needs to be returned the shipping materials can be reused to ensure it arrives safely at its destination.

Installing the Optical Tube on the Base

Your new TableTop telescope arrives with the optical tube already attached to the base. If for any reason you wish to separate the components this is easily done. It may be helpful to loosen the Altitude Tension Adjustment knob and rotate the telescope so that the Telescope Securing Knob is in a more accessible position. While holding the optical tube with one hand loosen the Telescope Securing Knob until you can lift the optical tube out of the Dovetail Holder. The included dovetail is compatible with most other Orion mounts and many other brands as well. The female threads on the bottom are ¼"-20 and will fit standard photo tripods.

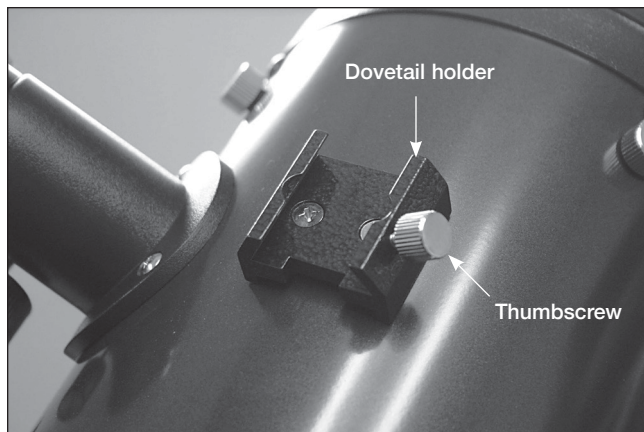

Figure 2: Detail of the Finder scope base



Figure 3: The EZ Finder II securing thumbnuts

To re-install the tube onto the base make sure the Dovetail Bar is flush with the edge of the Dovetail Holder. Place the Dovetail Bar into the Dovetail Holder so that one of the indentations in the bar aligns with the Telescope Securing Knob and tighten until secure. We suggest using the center indentation to achieve the best balance point. Depending on your accessories you may determine a different position best suits your needs.

Attaching the EZ Finder II 80 & 90mm Models

Slide the base of the EZ Finder II bracket into the dovetail holder that is pre-installed on the optical tube. The EZ Finder II should be oriented so that it appears as in Figure 1. Tighten the thumbscrew on the dovetail holder to secure the EZ Finder II in place. (See Figure 2.)

100mm Model

Remove the two metal thumbnuts from the optical tube. Place the bracket of the Red-dot finder on the tube so that the holes in the bracket slide over the two threaded posts on the tube. The EZ Finder should be oriented so that it appears as in Figure 1. Thread the thumbscrews back onto the posts to secure the Red-dot finder in place. (See Figure 3.)

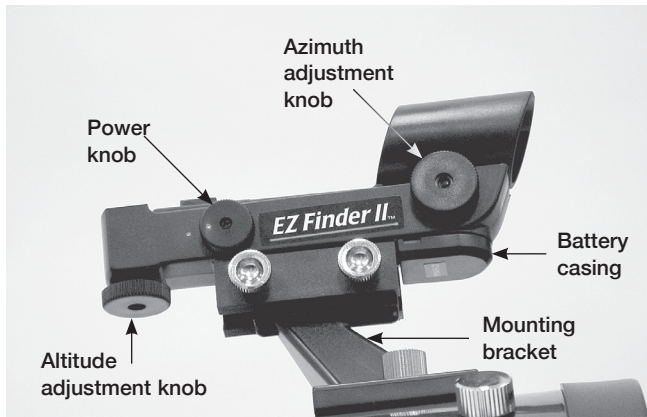

Figure 4. The EZ Finder II reflex sight.



Figure 5. The EZ Finder II superimposes a tiny red dot on the sky, showing right where the telescope is pointed.

Operating the EZ Finder II Reflex Sight

The EZ Finder II reflex sight makes pointing your telescope almost as easy as pointing your finger! It's a non-magnifying aiming device that superimposes a dot on the sky, showing exactly where the telescope is pointed. The EZ Finder II works by projecting a tiny red dot produced by a light emitting diode (LED), not a laser beam, onto a lens mounted in the front of the unit. When you look through the reflex sight, the red dot will appear to float in space.

The first time you use the EZ Finder II you will need to remove the clear plastic tab near the battery cover; this tab prevents the batteries from accidentally being drained during shipment. Turn the power knob clockwise until you hear the "click" indicating that power has been turned on. Look through the back of the reflex sight with both eyes open to see the red dot. Position your eye at a comfortable distance from the back of the sight. The intensity of the dot is adjusted by turning the power knob. For best results when stargazing, use the dimmest possible setting that allows you to see the dot without difficulty. Typically a dimmer setting is used under dark skies and a bright setting is used under light-polluted skies or daylight. (See Figure 4.)

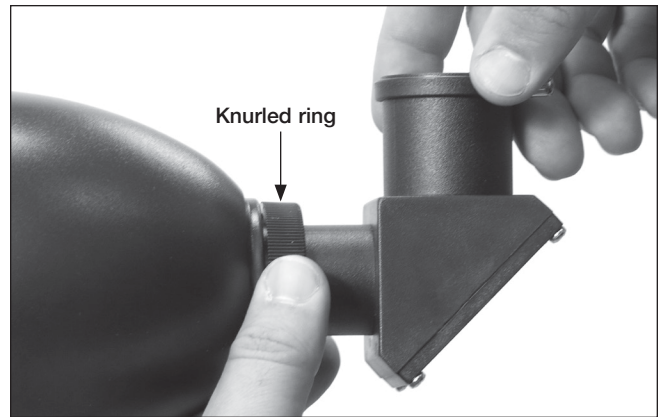

Figure 6. The knurled ring of the diagonal connects to the threads on the rear of the GoScope. To change the viewing angle, loosen the knurled ring, rotate the diagonal, then retighten the ring.

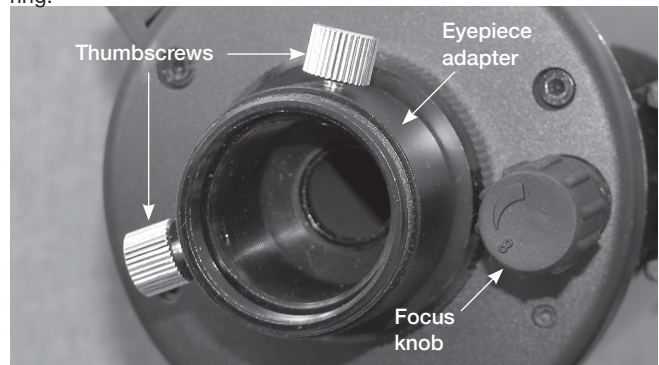

Figure 7: Detail of the TableTop 90 eyepiece adapter

Aligning the EZ Finder II Reflex Sight

When the EZ Finder II is properly aligned with the telescope, an object that is centered on reflex sight's red dot should also appear in the center of the field of view of the telescope's eyepiece. Alignment of the sight is easiest during daylight, before observing at night.

1. Aim the telescope at a distant object such as a telephone pole or roof chimney and center it in the telescope's eyepiece. The object should be at least 1/4 mile away. Now, with the EZ Finder II turned on, look through it. The object will appear in the field of view near the red dot.
2. Without moving the main telescope, use the EZ Finder II's azimuth (left/right) and altitude (up/down) adjustment knobs to center the red dot on the object in the eyepiece.
3. When the red dot is centered on the distant object, check to make sure that the object is still centered in the telescope's field of view. If not, re-center it and adjust the EZ Finder II's alignment again. When the object is centered in the eyepiece and on the reflex sight's red dot, the EZ Finder II is properly aligned with the telescope and is ready to be used.

The EZ Finder II alignment should be checked before every observing session. Choose any distant target (during the day) or bright star (at night), center the object in the telescope's eyepiece, and then adjust the knobs until the

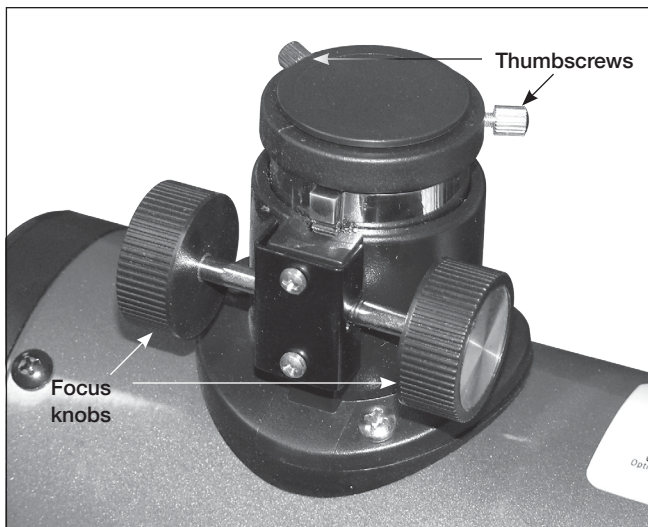

Figure 8: Detail of the TableTop 100 focuser

object is centered on the red dot of the reflex sight. (See Figure 5.)

At the end of your observing session, be sure to turn the power knob counterclockwise until it clicks off. When the two white dots on the EZ Finder II's body and power knob are lined up, the EZ Finder II is turned off.

Replacing the Battery

Replacement 3-volt lithium (CR-2032) batteries are available from many retail outlets. Remove the old battery by inserting a small flat-head screwdriver into the slot on the battery cover and gently prying open the cover. Then carefully pull back on the retaining clip and remove the old battery. Do not over bend the retaining clip. Then slide the new battery under the battery lead with the positive (+) side facing down and replace the battery cover.

Attaching the Diagonal

GoScope 80

Attach the 90° star diagonal to the optical tube. First remove the caps from the diagonal and unthread the cover on the rear of the GoScope. The knurled ring on the diagonal connects to the threads on the rear of the GoScope. Tighten this ring firmly. If you wish to change the orientation of the diagonal for a more comfortable viewing angle, you must first loosen the knurled ring on the diagonal. Rotate the diagonal to the desired viewing angle, and retighten the knurled ring to lock the diagonal into place. (See Figure 6.)

StarMax 90

Remove the cap from the eyepiece adapter on the rear of the optical tube and insert the chrome barrel of the mirror star diagonal. Secure the diagonal with the thumbscrews on the eyepiece adapter. Now, insert the chrome barrel of the 25mm eyepiece into the star diagonal. Secure the eyepiece with the thumbscrews on the star diagonal. (See Figure 7.)

SkyScanner 100

This section is not applicable if you own the SkyScanner 100. This is because this telescope is a Newtonian reflector and this telescope type does not have the focus travel to support this accessory. Please skip to the next section.

Inserting the Eyepiece

Loosen the eyepiece securing thumbscrews. Insert the chrome barrel of the low-power eyepiece into the focuser and secure it with the thumbscrews. Set aside the high-power eyepiece for use later. (See Figure 8.)

Your telescope is now fully assembled and should resemble the appropriate image on the cover of this manual. Remove the dust cap from the front of the telescope when it is in use. Replace it when you are finished observing.

Eyepiece Selection

By using eyepieces of different focal lengths, it is possible to attain many magnifications or powers with the TableTop. Your telescope comes with two eyepieces: one for low power, wide field viewing, another for detailed high power observation. Other eyepieces can be used to achieve higher or lower powers. It is quite common for an observer to own five or more eyepieces to access a wide range of magnifications.

To calculate the magnification of a telescope-eyepiece combination, simply divide the focal length of the telescope by the focal length of the eyepiece. The example below uses the GoScope 80mm TableTop with a focal length of 350mm as an example. See the Specifications table at the end of this manual to determine the focal length of your particular model.

$$\text{Magnification} = \frac{\text{Focal Length of Telescope (mm)}}{\text{Focal Length of Eyepiece (mm)}}$$

For example, the TableTop 80, which has a focal length of 350mm, used in combination with the 20mm eyepiece, yields a magnification of 18x:

$$18X = \frac{350\text{mm}}{20\text{mm}}$$

Whatever you choose to view, always start by inserting your lowest-power (longest focal length) eyepiece to locate and center the object. Low magnification yields a wide field of view, which shows a larger area of sky in the eyepiece. This makes finding and centering an object much easier. Trying to find and center objects with a high power (narrow field of view) eyepiece is like trying to find a needle in a haystack!

Once you've centered the object in the eyepiece, you can switch to a higher magnification (shorter focal length) eyepiece, if you wish. This is recommended for small and bright objects, like planets and double stars. The Moon takes higher magnifications well.

The best rule of thumb with eyepiece selection is to start with a low power, wide-field eyepiece, and then work your way up in magnification. If the object looks better, try an

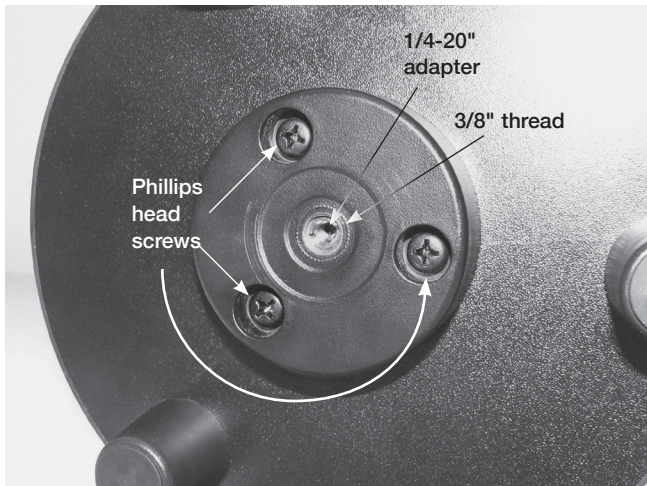

Figure 9a: Detail of the Photo tripod adapter

even higher magnification eyepiece. If the object looks worse, then back off the magnification a little by using a lower-power eyepiece.

Getting Started

It's best to get a feel for the basic functions of the TableTop during the day, before observing astronomical objects at night. This way you won't have to orient yourself in the dark! Find a spot outdoors where you'll have plenty of room to move the telescope, and where you'll have a clear view of some object or vista that is at least 1/4 mile away. It is not critical that the telescope be exactly level, but it should be placed on flat ground or pavement to ensure smooth movement.

The TableTop was designed specifically for visual observation of astronomical objects in the night sky. Like all Newtonian reflector telescopes, it is not suited for daytime terrestrial usage because the image in the eyepiece is inverted (upside-down). The eyepiece will also be too low to the ground for comfortable viewing when pointed near the horizon.

Placing the TableTop

One of the great assets of the TableTop is its extremely portable size. Due to its overall short length, you will find that viewing while sitting down on the ground next to the telescope is the most comfortable. If you wish to raise the telescope off the ground so that it can be used while standing or sitting in a chair, then a platform, such as a milk crate or table can be used.

Using the TableTop on a Tripod

One useful feature of the TableTop line is the inclusion of a built-in photo tripod adapter allowing you to mount the base on a standard photo tripod. This is best done as a tripod only – without a panhead mounted on it. Most photo tripods use either a 3/8" or 1/4"-20 thread to attach a panhead. Using this same post you can thread the TableTop

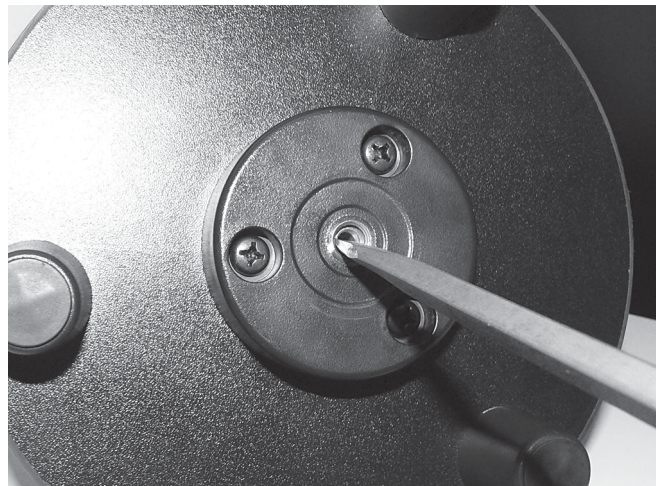

Figure 9b: Removing the 1/4"-20 adapter

base directly to your tripod giving you maximum versatility in setting up your telescope. The TableTop base includes a 3/8" female thread and a pre-assembled 1/4"-20 stainless steel adapter. You can remove the adapter using a flat head screwdriver. Simply thread the base onto the post until it is tight. (See Figures 9a, 9b, 10.)

Altitude and Azimuth (Aiming the Telescope)

The TableTop altazimuth base permits motion along two axes: altitude (up/down) and azimuth (left/right). Moving the telescope up/down and right/left is the "natural" way people search for objects; which makes pointing the telescope intuitive and easy.

Simply take hold of the telescope tube opening at the top or the side brace and move it left or right so that the base rotates. Move it up or down in the same manner. Both motions can be made simultaneously and in a continuous manner for easy aiming. This way you can point to any position in the night sky, from horizon to horizon.

Altitude Tension Adjustment

When aiming the telescope in altitude, you may find that the optical tube is either too hard to move or does not stay in place. Use the altitude adjustment tension knob to change the amount of tension between the optical tube and the altazimuth base to find the right level of tension to properly move and balance the telescope. (Refer to Figure 1d to identify the Altitude Tension Knob).

Azimuth Tension Adjustment

In the event that adjustments to the azimuth axis need to be made you will first need to remove the Photo Tripod Adapter. This is very easy to do. Simply loosen and remove the three phillips-head screws on the underside of the base (Figure 9a). The Adapter will lift right off of the base. Once you have made the necessary adjustments reinstall by aligning the holes in the adapter to the holes on the base plate and re-tighten the three Phillips-head screws. If you are not taking advantage of the tripod mounting you

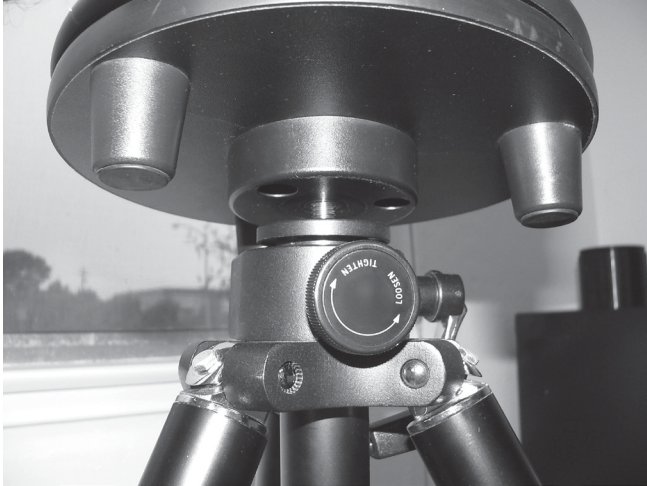

Figure 10: Mounting the TableTop base on a photo tripod

can leave this base off. Store it in a safe place with the hardware in case you wish to use it later.

To adjust the azimuth tension you will need to tighten or loosen the lock nut on the circular plate at the base of the telescope. This is very easy to do; though it will require the use of two wrenches. The first is needed to hold the bolt underneath the base while the second is used to adjust the lock nut at the top of the base. Because these telescopes are so lightweight it is not unusual that you may be able to spin the lock nut with your fingers. This does not necessarily indicate that the assembly is too loose. As long as the base moves without tension and the base plates do not wobble further adjustment is not necessary. (See Figure 11.)

Focusing the Telescope

Using the lower power eyepiece inserted and secured with the thumbscrews, aim the optical tube so the front end is pointing in the general direction of an object at least 1/4-mile away. With your fingers, slowly rotate one of the focus wheels until the object comes into sharp focus. A good method to ensure you've hit the exact focus point is go a little bit beyond sharp focus until the image starts to blur again, then reverse the rotation of the knob and stop when sharp focus has been achieved again.

Using Your Telescope

Choosing an Observing Site

When selecting a location for observing, get as far away as possible from direct artificial light such as streetlights, porch lights, and automobile headlights. The glare from these lights will greatly impair your dark-adapted night vision. Avoid viewing over rooftops and chimneys, as they often have warm air currents rising from them. Similarly, avoid observing indoors through a window, either open or closed, because the temperature difference between the indoor and outdoor air will cause image blurring and dis-



Figure 11: Making optional adjustments to the azimuth tension

ortion. Window glass may also introduce glare, internal reflections, or double-images into your view.

If at all possible, escape the light-polluted city sky and head for darker country skies. You will be amazed at how many more objects are visible in a dark sky!

“Seeing” and Transparency

Atmospheric conditions vary significantly from night to night. “Seeing” refers to the steadiness of the Earth’s atmosphere at a given time. In conditions of poor seeing, atmospheric turbulence causes objects viewed through the telescope to “boil”. If, when you look up at the sky with your naked eyes, the stars are twinkling noticeably, the seeing is bad and you will be limited to viewing with low powers (bad seeing affects images at high powers more severely). Planetary observing may also be poor.

In conditions of good seeing, star twinkling is minimal and images appear steady in the eyepiece. Seeing is best overhead, worst at the horizon. Also, seeing generally gets better after midnight, when much of the heat absorbed by the Earth during the day has radiated off into space.

Especially important for observing faint objects is good “transparency” – air free of moisture, smoke, and dust. All tend to scatter light, which reduces an object’s brightness. Transparency is judged by the magnitude of the faintest stars you can see with the unaided eye (6th magnitude or fainter is desirable).

If you cannot see stars of magnitude 3.5 or dimmer then conditions are poor. Magnitude is a measure of how bright a star is – the brighter a star is, the lower its magnitude will be. A good star to remember for this is Megrez (mag. 3.4), which is the star in the “Big Dipper” connecting the handle to the “dipper”. If you cannot see Megrez, then you have fog, haze, clouds, smog, or other conditions that are hindering your viewing.

Magnification Limits

Every telescope has a useful magnification limit of about 2X per millimeter of aperture. This comes to 200X for the SkyScanner 100mm TableTop. Some telescope manufacturers will use misleading claims of excess magnification, such as “See distant galaxies at 640X!”. While such magnifications are technically possible, the actual image at that magnification would be an indistinct blur.

Moderate magnifications are what give the best views. It is better to view a small, but bright and detailed image than a dim, unclear, oversized image.

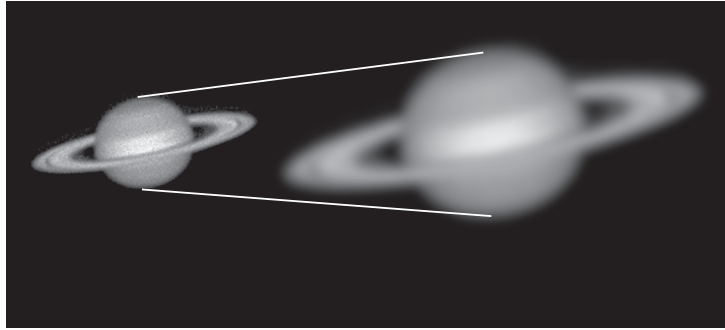

Tracking Celestial Objects

The Earth is constantly rotating about its polar axis, completing one full rotation every 24 hours; this is what defines a “day”. We do not feel the Earth rotating, but we see it at night from the apparent movement of stars from east to west.

When you observe any astronomical object, you are watching a moving target. This means the telescope’s position must be continuously adjusted over time to keep an object in the field of view. This is easy to do with the TableTop because of its smooth motions on both axes. As the object moves off towards the edge of the field of view, just lightly nudge the telescope to re-center it.

Objects appear to move across the field of view faster at higher magnifications. This is because the field of view becomes narrower. Objects seen through the eyepiece will be upside down and reversed left-to right on reflectors. On telescopes that accept a diagonal the image will be right side up. Star diagonals will still be reversed left-right, correct image diagonals will provide images that are right side up and non-reversed, as seen with the naked eye.

Magnification Limits

Every telescope has a useful magnification limit of about 2X per millimeter of aperture. This comes to 160X for the 80mm TableTop. Some telescope manufacturers will use misleading claims of excess magnification, such as “See distant galaxies at 640X!”. While such magnifications are technically possible, the actual image at that magnification would be an indistinct blur.

Moderate magnifications are what give the best views. It is better to view a small, but bright and detailed image than a dim, unclear, oversized image.

What to Expect

So what will you see with your telescope? You should be able to see bands on Jupiter, the rings of Saturn, craters

on the Moon, the waxing and waning of Venus, and many bright deep-sky objects. Do not expect to see color as you do in NASA photos, since those are taken with long-exposure cameras and have “false color” added. Our eyes are not sensitive enough to see color in deep-sky objects except in a few of the brightest ones.

Remember that you are seeing these objects using your own telescope with your own eyes! The object you see in your eyepiece is in real-time, and not some conveniently provided image from an expensive space probe. Each session with your telescope will be a learning experience. Each time you work with your telescope it will get easier to use, and stellar objects will become easier to find. Take it from us, there is big difference between looking at a well-made full-color NASA image of a deep-sky object in a lit room during the daytime, and seeing that same object in your telescope at night. One can merely be a pretty image someone gave to you. The other is an experience you will never forget!

Objects to Observe

Now that you are all set up and ready to go, one critical decision must be made: what to look at?

A. The Moon

With its rocky surface, the Moon is one of the easiest and most interesting targets to view with your telescope. Lunar craters, maria, and even mountain ranges can all be clearly seen from a distance of 238,000 miles away! With its ever-changing phases, you’ll get a new view of the Moon every night. The best time to observe our one and only natural satellite is during a partial phase, that is, when the Moon is NOT full. During partial phases, shadows are cast on the surface, which reveal more detail, especially right along the border between the dark and light portions of the disk (called the “terminator”). A full Moon is too bright and devoid of surface shadows to yield a pleasing view. Make sure to observe the Moon when it is well above the horizon to get the sharpest images.

Use an optional Moon filter to dim the Moon when it is very bright. It simply threads onto the bottom of the eyepieces (you must first remove the eyepiece from the focuser to attach a filter). You'll find that the Moon filter improves viewing comfort, and also helps to bring out subtle features on the lunar surface.

B. The Sun

Warning: Do not look at the Sun with any optical instrument without a professionally made solar filter, or permanent eye damage could result

You can change your nighttime telescope into a daytime Sun viewer by installing an optional full-aperture solar filter over the front opening of the TableTop. The primary attraction is sunspots, which change shape, appearance, and location daily. Sunspots are directly related to magnetic activity in the Sun. Many observers like to make drawings of sunspots to monitor how the Sun is changing from day to day.

C. The Planets

The planets don't stay put like the stars, so to find them you should refer to Sky Calendar at our website (OrionTelescopes.com), or to charts published monthly in *Astronomy*, *Sky & Telescope*, or other astronomy magazines. Venus, Jupiter, and Saturn are the brightest objects in the sky after the Sun and the Moon. Your TableTop is capable of showing you these planets in some detail. Other planets may be visible but will likely appear star-like. Because planets are quite small in apparent size, optional higher-power eyepieces are recommended and often needed for detailed observations. Not all the planets are generally visible at any one time.

JUPITER: The largest planet, Jupiter, is a great subject for observation. You can see the disk of the giant planet and watch the ever-changing positions of its four largest moons – Io, Callisto, Europa, and Ganymede.

SATURN: The ringed planet is a breathtaking sight when it is well positioned. The tilt angle of the rings varies over a period of many years; sometimes they are seen edge-on, while at other times they are broadside and look like giant "ears" on each side of Saturn's disk. A steady atmosphere (good seeing) is necessary for a good view. You will probably see a bright "star" close by, which is Saturn's brightest moon, Titan.

VENUS: At its brightest, Venus is the most luminous object in the sky, excluding the Sun and the Moon. It is so bright that sometimes it is visible to the naked eye during full daylight! Ironically, Venus appears as a thin crescent, not a full disk, when at its peak brightness. Because it is so close to the Sun, it never wanders too far from the morning or eve-

ning horizon. No surface markings can be seen on Venus, which is always shrouded in dense clouds.

D. The Stars

Stars will appear like twinkling points of light. Even powerful telescopes cannot magnify stars to appear as more than a point of light. You can, however, enjoy the different colors of the stars and locate many pretty double and multiple stars. The gorgeous two-color double star Albireo in Cygnus is a favorite. Defocusing a star slightly can help bring out hints of color.

E. Deep-Sky Objects

Under dark skies, you can observe a wealth of fascinating deep-sky objects, including gaseous nebulae, open and globular star clusters, and a variety of different types of galaxies. Most deep-sky objects are very faint, so it is important that you find an observing site well away from light pollution. Take plenty of time to let your eyes adjust to the darkness. Do not expect these subjects to appear like the photographs you see in books and magazines; most will look like dim gray smudges. Our eyes are not sensitive enough to see color in deep-sky objects except in a few of the brightest ones. But as you become more experienced and your observing skills get sharper, you will be able to ferret out more and more subtle details and structure.

To find deep sky objects in the sky, it is best to consult a star chart or Planisphere. These guides will help you locate the brightest and best deep-sky objects for viewing with your TableTop.

You can also try low-power scanning of the Milky Way. Use the 20mm eyepiece and just cruise through the "star clouds" of our galaxy. You'll be amazed at the rich fields of stars and objects you'll see! The Milky Way is best observed on summer and winter evenings.

Viewing Hints

Amateur astronomy can be an entertaining and educational activity for the entire family. Astronomy is also a serious scientific pursuit. As with any science you will achieve the best results by following some basic guidelines. These recommendations will assist you in getting the most out of your new telescope. This is just a sample of suggested techniques; for more helpful tips please visit the Learning Center at OrionTelescopes.com.

Light Pollution

Most of us live where city lights interfere with our view of the heavens. As our metropolitan areas have become more developed, the scourge of light pollution has spread, washing out many stars and nonstellar celestial objects

Do You Wear Eyeglasses?

If you wear eyeglasses, you may be able to keep them on while you observe. In order to do this, your eyepiece must have enough “eye relief” to allow you to see the entire field of view with glasses on. You can try looking through the eyepiece first with your glasses on and then with them off, to see if the glasses restrict the view to only a portion of the full field. If the glasses do restrict the field of view, you may be able to observe with your glasses off by just refocusing the telescope to your unaided vision.

If your eyes are astigmatic, images will probably appear best with glasses on. This is because a telescope’s focuser can accommodate for nearsightedness or farsightedness, but not astigmatism. If you have to wear your glasses while observing and cannot see the entire field of view, you may want to purchase additional eyepieces that have longer eye relief.

Short eye relief restricts the field of view for eyeglass wearers.



Long eye relief allows full field of view to be seen with or without eyeglasses.



from our sight. Faint deep sky objects become difficult or impossible to see through the murk of light pollution. Even bright nebulas like the Orion and Lagoon Nebulas lose much of their delicate detail. The Moon and planets are not affected; they require steady air more than dark skies, so they remain good targets for city-dwelling observers.

The International Dark-Sky Association is waging the fight against light pollution. The IDSA was founded in 1988 with the mission of educating the public about the adverse impact that light pollution has on the night sky and astronomy. Through educational and scientific means, the non-profit IDA works to raise awareness about the problem and about measures that can be taken to solve it.

Do you need help dealing with local officials to control street or building lighting in your area? The IDA’s extensive support materials can show you how. Help preserve dark skies, join the IDA today! For information, write to IDA, 3225 N. First Ave., Tucson, AZ 85719-2103 or visit their website: www.darksky.org.

The best way to avoid immediate problems with light pollution, however, is to take your telescope to where there are dark skies. You will be amazed at how many stars you can see when you get away from the city lights.

Do You Wear Eyeglasses?

If you wear eyeglasses, you may be able to keep them on while you observe. In order to do this, your eyepiece must have enough “eye relief” to allow you to see the entire field of view with glasses on. You can try looking through the eyepiece first with your glasses on and then with them off, to see if the glasses restrict the view to only a portion of the full field. If the glasses do restrict the field of view, you may be able to observe with your glasses off by just refocusing the telescope to your unaided vision.

If your eyes are astigmatic, images will probably appear best with glasses on. This is because a telescope’s focuser can accommodate for nearsightedness or farsightedness, but not astigmatism. If you have to wear your glasses while observing and cannot see the entire field of view, you may

want to purchase additional eyepieces that have longer eye relief.

Image Orientation

Every beginning astronomer has to grapple with the topsy-turvy topic of image orientation in the telescope. Depending on the type of telescope and whether or not it is used in combination with a star diagonal, the image you see may be either upside-down, backwards, rotated, or normally oriented.

For most astronomical observing, it makes little difference if an object is seen upside-down or at an otherwise odd angle (after all, there’s no “right side up” in space!). However, for terrestrial viewing you certainly don’t want to see everything upside-down. And when stargazing, it’s hard to compare what you’re seeing to your star chart if the image is inverted or flopped. Let’s sort out the different image orientations seen through different types of telescopes, and see how diagonals figure in the equation.

Refractor and Cassegrain telescopes, when used without a diagonal (which isn’t usually the case), produce an inverted (upside-down) image. The view in Newtonian reflectors is also inverted, or rotated at an angle depending on the eyepiece angle with respect to vertical. Straight-through finderscopes also invert the field of view. If you’re using a star chart, all you have to do is turn it upside down to match the view through the eyepiece.

Refractor or Cassegrain telescopes used in combination with a standard 90 degree “star diagonal” will provide a right-side-up, but backwards (mirror-reversed), image. Using a star chart is difficult; you have to read it from the back, or do the mental gymnastics to flip the image in the eyepiece left to right to match the chart.

Fortunately, there are special “erect-image” or “correct-image” prism diagonals available that solve the problem, providing a correctly oriented view. Porro prisms (classical erecting prisms) provide correct images while allowing viewing straight through the scope. They do not work with Newtonian reflectors, however.

Care and Maintenance

If you give your telescope reasonable care, it will last a lifetime. Store it in a clean, dry, dust-free place, safe from rapid temperature changes and humidity. Do not store the telescope outdoors, although storage in a garage or shed is OK. Small components like eyepiece and other accessories should be kept in a protective box or storage case. Keep the dust caps on the front of the scope and on the focuser when it is not in use.

The telescope requires very little mechanical maintenance. The optical tube is made of steel and has a smooth painted finish that is fairly scratch resistant. If a scratch does appear on the tube, it will not harm the telescope. Smudges on the tube can be wiped off with a soft cloth and a household cleaner such as Windex or Formula 409.

Refer to Appendix B for detailed instructions on how to clean the optics of the TableTop.

Eyepieces	25mm (50x) and 10mm (125x), fully coated
Finder scope	EZ Finder II reflex sight
Optical tube mounting block	Fits Orion Dovetail mounts and 1/4"-20 photo tripods
Weight	6.5 lbs (tube 3.7 lbs, mount 2.8 lbs)

Specifications

#9549 GoScope 80 TableTop

Optical design	Refractor
Objective lens	Achromatic, air-spaced, fully coated
Aperture	80mm
Focal length	350mm
Focal ratio	f/4.3
Diagonal	90° prism, accepts 1.25" eyepieces
Eyepieces	20mm eyepiece (18x) and 10mm eyepiece (35x), fully coated, 1.25"
Finder scope	EZ Finder II reflex sight
Optical tube mounting block	Fits Orion Dovetail mounts and 1/4"-20 photo tripods
Total weight	5.7 lbs. (tube 2.9 lbs, mount 2.8 lbs)

#9909 StarMax 90 TableTop

Optical design	Maksutov-Cassegrain
Primary mirror coating	Aluminum with SiO ₂ overcoat
Meniscus lens coating	Anti-reflection multi-coatings on both sides of lens
Aperture	90mm
Focal length	1250mm
Focal ratio	f/13.9
Central obstruction diameter	29mm
Eyepiece adapter	Accepts 1.25" accessories, camera T-threads
Diagonal	90° mirror star diagonal, 1.25"

#9541 SkyScanner 100 TableTop

Optical design	Reflector
Primary mirror	Parabolic
Primary mirror coating	Aluminum with SiO ₂ overcoat
Secondary mirror diameter	
Aperture	100mm
Focal length	400mm
Focal ratio	f/4
Focuser	1.25" Rack & Pinion
Eyepieces	20mm (20x) and 10mm (40x) fully coated
Finder scope	EZ Finder II reflex sight
Optical tube mounting block	Fits Orion Dovetail mounts and 1/4"-20 photo tripods
Weight	6.2 lbs (tube 3.4 lbs, mount 2.8 lbs)

Appendix A: Collimating (Aligning the Mirrors)

Collimating is the process of adjusting the mirrors so they are perfectly aligned with one another. Your telescope's optics were aligned at the factory, and should not need much adjustment unless the telescope is handled roughly. It is only recommended you make changes if the telescope is grossly out of alignment. Slight variations should still provide acceptable viewing under most conditions.

To check collimation (mirror alignment), remove the eyepiece and look down the focuser. You should see the secondary mirror centered in the drawtube, as well as the reflection of the primary mirror centered in the secondary mirror, and the reflection of the secondary mirror (and your eye) centered in the reflection of the primary mirror, as in.

Star-Testing the Telescope

When it is dark, point the telescope at a bright star and accurately center it in the eyepiece's field of view. Slowly de-focus the image with the focusing knob. If the telescope is correctly collimated, the expanding disk should be a perfect circle. If the image is unsymmetrical, the scope is out of collimation. The dark shadow cast by the secondary mirror should appear in the very center of the out-of-focus circle, like the hole in a donut. If the "hole" appears off-center, the telescope is out of collimation.

NOTE: If you try the star test and the bright star you have selected is not accurately centered in the eyepiece, the optics will always appear out of collimation, even though they may be perfectly aligned. It is critical to keep the star centered, so over time you will need to make slight corrections to the telescope's position in order to account for the sky's apparent motion.

Aligning the Secondary Mirror

Only the secondary mirror can be adjusted on the TableTop. If the secondary mirror seems off center, or the star test as described above is showing an elliptical or off center diffraction pattern you may need to adjust the tilt of the mirror using the three allen-head screws on the secondary holder.

Appendix B: Cleaning the Optics

Cleaning Lenses

Any quality optical lens cleaning tissue and optical lens cleaning fluid specifically designed for multi-coated optics can be used to clean the exposed lenses of your eyepieces. Never use regular glass cleaner or cleaning fluid designed for eyeglasses.

Before cleaning with fluid and tissue, blow any loose particles off the lens with a blower bulb or compressed air. Then apply some cleaning fluid to a tissue, never directly on the optics. Wipe the lens gently in a circular motion, then remove any excess fluid with a fresh lens tissue. Oily fingerprints and smudges may be removed using this method. Use caution; rubbing too hard may scratch the lens. On larger lenses, clean only a small area at a time, using a fresh lens tissue on each area. Never reuse tissues.

Cleaning Mirrors

You should not have to clean the telescope's mirror very often. Covering the telescope with the dust cap when it is not in use will help prevent dust from accumulating on the mirrors. However, when bringing the telescope inside after an evening's viewing it is normal for moisture to accumulate on the mirror due to the change in temperature. We suggest leaving it uncovered overnight to allow this condensation to evaporate. Improper cleaning can scratch mirror coatings, so the fewer times you have to clean the mirrors, the better. Small specks of dust or flecks of paint have virtually no effect on the visual performance.

If either mirror needs cleaning please email us at: support@telescope.com or contact Orion Technical Support at (800) 676-1343.



One-Year Limited Warranty

This Orion product is warranted against defects in materials or workmanship for a period of one year from the date of purchase. This warranty is for the benefit of the original retail purchaser only. During this warranty period Orion Telescopes & Binoculars will repair or replace, at Orion's option, any warranted instrument that proves to be defective, provided it is returned postage paid. Proof of purchase (such as a copy of the original receipt) is required. This warranty is only valid in the country of purchase.

This warranty does not apply if, in Orion's judgment, the instrument has been abused, mishandled, or modified, nor does it apply to normal wear and tear. This warranty gives you specific legal rights. It is not intended to remove or restrict your other legal rights under applicable local consumer law; your state or national statutory consumer rights governing the sale of consumer goods remain fully applicable.

For further warranty information, please visit www.OrionTelescopes.com/warranty.



Corporate Offices: 89 Hangar Way, Watsonville CA 95076 - USA
Toll Free USA & Canada: (800) 447-1001
International: +1(831) 763-7000
Customer Support: support@telescope.com

Copyright © 2020 Orion Telescopes & Binoculars. All Rights Reserved. No part of this product instruction or any of its contents may be reproduced, copied, modified or adapted, without the prior written consent of Orion Telescopes & Binoculars.