

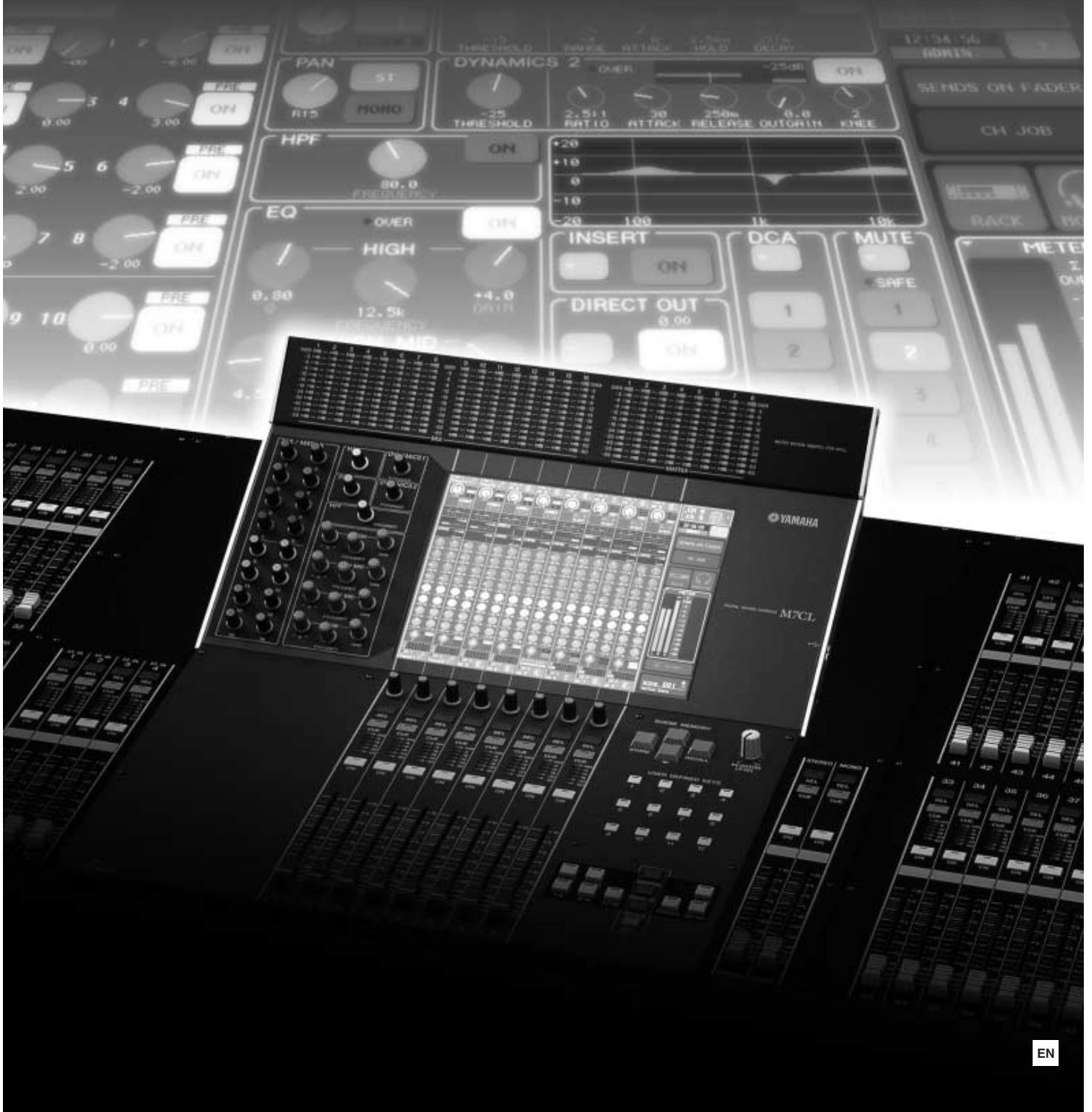

DIGITAL MIXING CONSOLE **M7CL**

Owner's Manual



FCC INFORMATION (U.S.A.)

1. IMPORTANT NOTICE: DO NOT MODIFY THIS UNIT!

This product, when installed as indicated in the instructions contained in this manual, meets FCC requirements. Modifications not expressly approved by Yamaha may void your authority, granted by the FCC, to use the product.

2. IMPORTANT: When connecting this product to accessories and/or another product use only high quality shielded cables. Cable/s supplied with this product **MUST** be used. Follow all installation instructions. Failure to follow instructions could void your FCC authorization to use this product in the USA.

3. NOTE: This product has been tested and found to comply with the requirements listed in FCC Regulations, Part 15 for Class "B" digital devices. Compliance with these requirements provides a reasonable level of assurance that your use of this product in a residential environment will not result in harmful interference with other electronic devices. This equipment generates/uses radio frequencies and, if not installed and used according to the instructions found in the users manual, may cause interference harmful to the operation of other electronic devices. Compliance with FCC

regulations does not guarantee that interference will not occur in all installations. If this product is found to be the source of interference, which can be determined by turning the unit "OFF" and "ON", please try to eliminate the problem by using one of the following measures:

Relocate either this product or the device that is being affected by the interference.

Utilize power outlets that are on different branch (circuit breaker or fuse) circuits or install AC line filter/s.

In the case of radio or TV interference, relocate/reorient the antenna. If the antenna lead-in is 300 ohm ribbon lead, change the lead-in to co-axial type cable.

If these corrective measures do not produce satisfactory results, please contact the local retailer authorized to distribute this type of product. If you can not locate the appropriate retailer, please contact Yamaha Corporation of America, Electronic Service Division, 6600 Orangethorpe Ave, Buena Park, CA90620

The above statements apply **ONLY** to those products distributed by Yamaha Corporation of America or its subsidiaries.

* This applies only to products distributed by YAMAHA CORPORATION OF AMERICA.

(class B)

COMPLIANCE INFORMATION STATEMENT (DECLARATION OF CONFORMITY PROCEDURE)

Responsible Party : Yamaha Corporation of America
Address : 6600 Orangethorpe Ave., Buena Park,
Calif. 90620
Telephone : 714-522-9011
Type of Equipment : DIGITAL MIXING CONSOLE
Model Name : M7CL-48, M7CL-32

This device complies with Part 15 of the FCC Rules.
Operation is subject to the following two conditions:
1) this device may not cause harmful interference, and
2) this device must accept any interference received including interference that may cause undesired operation.
See user manual instructions if interference to radio reception is suspected.

* This applies only to products distributed by
YAMAHA CORPORATION OF AMERICA.

(FCC DoC)

IMPORTANT NOTICE FOR THE UNITED KINGDOM

Connecting the Plug and Cord

WARNING: THIS APPARATUS MUST BE EARTHED
IMPORTANT. The wires in this mains lead are coloured in accordance with the following code:

GREEN-AND-YELLOW : EARTH
BLUE : NEUTRAL
BROWN : LIVE

As the colours of the wires in the mains lead of this apparatus may not correspond with the coloured markings identifying the terminals in your plug proceed as follows:

The wire which is coloured GREEN-and-YELLOW must be connected to the terminal in the plug which is marked by the letter E or by the safety earth symbol  or colored GREEN or GREEN-and-YELLOW.

The wire which is coloured BLUE must be connected to the terminal which is marked with the letter N or coloured BLACK.

The wire which is coloured BROWN must be connected to the terminal which is marked with the letter L or coloured RED.

• This applies only to products distributed by
Yamaha-Kemble Music (U.K.) Ltd.

(3 wires)

This product contains a battery that contains perchlorate material.
Perchlorate Material—special handling may apply,
See www.dtsc.ca.gov/hazardouswaste/perchlorate.

* This applies only to products distributed by YAMAHA CORPORATION OF AMERICA. (Perchlorate)

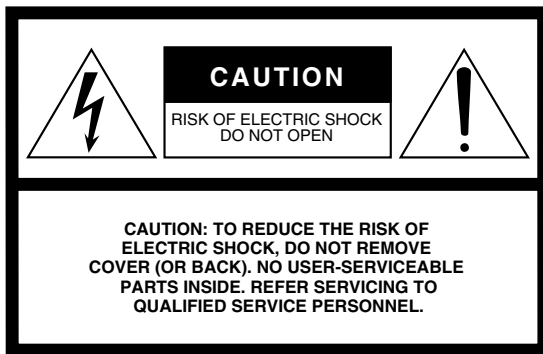

The above warning is located on the rear of the unit.

Explanation of Graphical Symbols

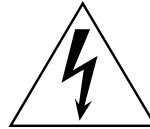

The lightning flash with arrowhead symbol within an equilateral triangle is intended to alert the user to the presence of uninsulated “dangerous voltage” within the product’s enclosure that may be of sufficient magnitude to constitute a risk of electric shock to persons.



The exclamation point within an equilateral triangle is intended to alert the user to the presence of important operating and maintenance (servicing) instructions in the literature accompanying the product.

IMPORTANT SAFETY INSTRUCTIONS

- 1 Read these instructions.
- 2 Keep these instructions.
- 3 Heed all warnings.
- 4 Follow all instructions.
- 5 Do not use this apparatus near water.
- 6 Clean only with dry cloth.
- 7 Do not block any ventilation openings. Install in accordance with the manufacturer’s instructions.
- 8 Do not install near any heat sources such as radiators, heat registers, stoves, or other apparatus (including amplifiers) that produce heat.
- 9 Do not defeat the safety purpose of the polarized or grounding-type plug. A polarized plug has two blades with one wider than the other. A grounding type plug has two blades and a third grounding prong. The wide blade or the third prong are provided for your safety. If the provided plug does not fit into your outlet, consult an electrician for replacement of the obsolete outlet.
- 10 Protect the power cord from being walked on or pinched particularly at plugs, convenience receptacles, and the point where they exit from the apparatus.

- 11 Only use attachments/accessories specified by the manufacturer.

- 12 Use only with the cart, stand, tripod, bracket, or table specified by the manufacturer, or sold with the apparatus. When a cart is used, use caution when moving the cart/apparatus combination to avoid injury from tip-over.



- 13 Unplug this apparatus during lightning storms or when unused for long periods of time.
- 14 Refer all servicing to qualified service personnel. Servicing is required when the apparatus has been damaged in any way, such as power-supply cord or plug is damaged, liquid has been spilled or objects have fallen into the apparatus, the apparatus has been exposed to rain or moisture, does not operate normally, or has been dropped.

WARNING

TO REDUCE THE RISK OF FIRE OR ELECTRIC SHOCK, DO NOT EXPOSE THIS APPARATUS TO RAIN OR MOISTURE.

(98-6500)

ADVARSEL!

Lithiumbatteri—Eksplussionsfare ved fejlagtig håndtering. Udskiftning må kun ske med batteri af samme fabrikat og type. Levér det brugte batteri tilbage til leverandoren.

VARNING

Explosionsfare ved felaktigt batteribyte. Använd samma batterityp eller en ekvivalent typ som rekommenderas av apparattillverkaren. Kassera använt batteri enligt fabrikantens instruktion.

VAROITUS

Paristo voi räjähtää, jos se on virheellisesti asennettu. Vaihda paristo ainoastaan laitevalmistajan suosittelemaan tyyppiin. Hävitä käytetty paristo valmistajan ohjeiden mukaisesti.

(lithium caution)

NEDERLAND / THE NETHERLANDS

- Dit apparaat bevat een lithium batterij voor geheugen back-up.
- This apparatus contains a lithium battery for memory back-up.
- Raadpleeg uw leverancier over de verwijdering van de batterij op het moment dat u het apparaat aan het einde van de levensduur of gelieve dan contact op te nemen met de vertegenwoordiging van Yamaha in uw land.
- For the removal of the battery at the moment of the disposal at the end of life please consult your retailer or Yamaha representative office in your country.
- Gooi de batterij niet weg, maar lever hem in als KCA.
- Do not throw away the battery. Instead, hand it in as small chemical waste.

(lithium disposal)

PRECAUTIONS

PLEASE READ CAREFULLY BEFORE PROCEEDING

* Please keep this manual in a safe place for future reference.



WARNING

Always follow the basic precautions listed below to avoid the possibility of serious injury or even death from electrical shock, short-circuiting, damages, fire or other hazards. These precautions include, but are not limited to, the following:

Power supply/Power cord

- Only use the voltage specified as correct for the device. The required voltage is printed on the name plate of the device.
- Use only the specified power supply (PW800W), if you use an external power supply.
- Do not place the power cord near heat sources such as heaters or radiators, and do not excessively bend or otherwise damage the cord, place heavy objects on it, or place it in a position where anyone could walk on, trip over, or roll anything over it.
- Be sure to connect to an appropriate outlet with a protective grounding connection. Improper grounding can result in electrical shock.

Do not open

- Do not open the device or attempt to disassemble the internal parts or modify them in any way. The device contains no user-serviceable parts. If it should appear to be malfunctioning, discontinue use immediately and have it inspected by qualified Yamaha service personnel.

Water warning

- Do not expose the device to rain, use it near water or in damp or wet conditions, or place containers on it containing liquids which might spill into any openings.
- Never insert or remove an electric plug with wet hands.

If you notice any abnormality

- If the power cord or plug becomes frayed or damaged, or if there is a sudden loss of sound during use of the device, or if any unusual smells or smoke should appear to be caused by it, immediately turn off the power switch, disconnect the electric plug from the outlet, and have the device inspected by qualified Yamaha service personnel.
- If this device power supply should be dropped or damaged, immediately turn off the power switch, disconnect the electric plug from the outlet, and have the device inspected by qualified Yamaha service personnel.



CAUTION

Always follow the basic precautions listed below to avoid the possibility of physical injury to you or others, or damage to the device or other property. These precautions include, but are not limited to, the following:

Power supply/Power cord

- Remove the electric plug from the outlet when the device is not to be used for extended periods of time, or during electrical storms.
- When removing the electric plug from the device or an outlet, always hold the plug itself and not the cord. Pulling by the cord can damage it.

Location

- When transporting or moving the device, always use two or more people. Attempting to lift the device by yourself may damage your back, result in other injury, or cause damage to the device itself.
- When transporting or moving the device, do not hold the display.
- Before moving the device, remove all connected cables.
- When setting up the device, make sure that the rear-panel power switch can be easily turned ON/OFF. If some trouble or malfunction occurs, immediately turn off the power switch and disconnect the plug from the outlet.
- Avoid setting all equalizer controls and faders to their maximum. Depending on the condition of the connected devices, doing so may cause feedback and may damage the speakers.
- Do not expose the device to excessive dust or vibrations, or extreme cold or heat (such as in direct sunlight, near a heater, or in a car during the day) to prevent the possibility of panel discoloration or damage to the internal components.

- Do not place the device in an unstable position where it might accidentally fall over.
- Do not block the vents. This device has ventilation holes at the rear to prevent the internal temperature from becoming too high. In particular, do not place the device on its side or upside down. Inadequate ventilation can result in overheating, possibly causing damage to the device(s), or even fire.
- Do not use the device in the vicinity of a TV, radio, stereo equipment, mobile phone, or other electric devices. Doing so may result in noise, both in the device itself and in the TV or radio next to it.

Connections

- Before connecting the device to other devices, turn off the power for all devices. Before turning the power on or off for all devices, set all volume levels to minimum.
- When connecting the device to PW800W, be sure to turn OFF the device and PW800W, then, connect the power cable (PSL360).
- Be sure to connect to a properly grounded power source. A ground screw is provided on the rear panel of this device for maximum safety and shock prevention. If the mains outlet is not grounded, be sure to connect the ground screw to a confirmed ground point before plugging the device into the mains. Improper grounding can result in electrical shock.

Handling caution

- When turning on the AC power in your audio system, always turn on the power amplifier LAST, to avoid speaker damage. When turning the power off, the power amplifier should be turned off FIRST for the same reason.
- Do not insert your fingers or hands in any gaps or openings on the device (vents).
- Avoid inserting or dropping foreign objects (paper, plastic, metal, etc.) into any gaps or openings on the device (vents) If this happens, turn off the power immediately and unplug the power cord from the AC outlet. Then have the device inspected by qualified Yamaha service personnel.
- Do not use the device or headphones for a long period of time at a high or uncomfortable volume level, since this can cause permanent hearing loss. If you experience any hearing loss or ringing in the ears, consult a physician.
- Do not rest your weight on the device or place heavy objects on it, and avoid use excessive force on the buttons, switches or connectors.
- Do not apply oil, grease, or contact cleaner to the faders. Doing so may cause problems with electrical contact or fader motion.

Backup battery

- This device has a built-in backup battery. When you unplug the power cord from the AC outlet, the current scene data and library data is retained. However, if the backup battery fully discharges, this data will be lost. When the backup battery is running low, the LCD display indicates "Low Battery!" when you starting up the system, (In this case, the Battery field indicates "LOW" or "NO" in the SET UP screen.) immediately save the data to a USB storage device, then have qualified Yamaha service personnel replace the backup battery.

XLR-type connectors are wired as follows (IEC60268 standard): pin 1: ground, pin 2: hot (+), and pin 3: cold (-).

Yamaha cannot be held responsible for damage caused by improper use or modifications to the device, or data that is lost or destroyed.

Always turn the power off when the device is not in use.

The performance of components with moving contacts, such as switches, volume controls, and connectors, deteriorates over time. Consult qualified Yamaha service personnel about replacing defective components.

This product contains a high intensity lamp that contains a small amount of mercury. Disposal of this material may be regulated due to environmental considerations.
For disposal information in the United States, refer to the Electronic Industries Alliance web site:
www.eiae.org

* This applies only to products distributed by YAMAHA CORPORATION OF AMERICA.
(mercury)

Contents

1. Introduction	9	Making HA (Head Amp) gain settings.....44
Thank you	9	Sending an input channel signal to the STEREO bus47
An overview of the M7CL.....	9	
Differences between the M7CL-48 and M7CL-32... 11		
The M7CL's channel structure	13	
About the MIX bus types (VARI / FIXED)	14	
About word clock	14	
Conventions in this manual.....	14	
About the firmware version.....	14	
2. Panels and controls	15	
Top panel.....	15	
Rear panel	22	
Under the front pad	24	
3. Basic operation of the M7CL	25	
Basic operations		
in the top panel / touch screen	25	
Pressing the touch screen	25	
Multiple selection (specifying a range)	25	
Special operations for keys	25	
Encoder operations	25	
Multifunction encoder operations.....	26	
The on-screen user interface	26	
Tabs.....	26	
Buttons	26	
Faders / Knobs	27	
List windows	27	
Keyboard window	27	
Popup windows	28	
Dialog boxes.....	28	
Viewing the touch screen	28	
Function access area	28	
Main area.....	29	
Entering names	30	
Using the tool buttons	31	
About the tool buttons.....	31	
Using libraries	31	
Initializing settings	35	
Copying/pasting settings	36	
Comparing two settings	36	
4. Connections and setup	39	
Connections	39	
Setting up to use the M7CL	43	
Restoring the current scene to the default state.....	43	
Word clock connections and settings	43	
5. Input channel operations	51	
Signal flow for input channels.....	51	
Specifying the channel name and icon	53	
Making HA (Head Amp) settings	55	
Sending the signal from an input channel to the STEREO/MONO buses	57	
Sending the signal from an input channel to a MIX bus	61	
Using the SELECTED CHANNEL section	61	
Using the Centralogic section	63	
Using the faders (SENDS ON FADER mode)	64	
Sending the signal from an input channel to the MATRIX buses	66	
Using the SELECTED CHANNEL section	66	
Using the Centralogic section	67	
6. Output channel operations	69	
Signal flow for output channels	69	
Specifying the channel name and icon	71	
Sending signals from MIX channels to the STEREO/MONO bus	72	
Sending signals from MIX channels and STEREO/MONO channels to MATRIX buses	75	
Using the SELECTED CHANNEL section	75	
Using the Centralogic section	76	
7. Operations in the SELECTED CHANNEL section	79	
About the SELECTED CHANNEL section.....	79	
About the SELECTED CHANNEL VIEW screen	80	
Operations in the SELECTED CHANNEL section	81	
8. Operations in the Centralogic section	87	
About the Centralogic section.....	87	
About the OVERVIEW screen	88	
Operations in the Centralogic section	90	
Fixing the channels or DCA groups of the Centralogic section	94	
9. Input/output patching	95	
Changing the output patch settings	95	
Changing the input patch settings.....	98	
Inserting an external device into a channel	100	
Directly outputting an INPUT channel	102	

10. EQ and Dynamics	105	14. Talkback / Oscillator	149
About EQ and dynamics	105	About the talkback and oscillator functions	149
Using EQ	105	Using talkback	149
Using dynamics	108	Using the oscillator	151
Using the EQ or Dynamics libraries	111		
EQ library	111	15. Meters	153
Dynamics library	111	Operations in the METER screen	153
		Using the MBM7CL meter bridge (option)	155
11. Grouping and linking	113		
About DCA Groups and Mute Groups	113	16. Graphic EQ and effects	157
Using DCA groups	113	About the virtual rack	157
Assigning channels to a DCA group	113	Virtual rack operations	158
Controlling DCA groups	115	Graphic EQ operations	161
Using mute groups	116	About the graphic EQ	161
Assigning channels to mute groups	116	Inserting a GEQ in a channel	161
Controlling mute groups	117	Using the 31 Band GEQ	163
Using the Mute Safe function	119	Using the Flex15GEQ	165
The Channel Link function	120	About the internal effects	167
Linking the desired input channels	120	Using an internal effect	
Copying, moving, or initializing a channel	122	via send/return	168
Copying the parameters of a channel	122	Inserting an internal effect into a channel	170
Moving the parameters of a channel	123	Editing the internal effect parameters	171
Initializing the parameters of a channel	124	Using the Tap Tempo function	173
		Using the Freeze effect	175
12. Scene memory	125	Using the graphic EQ and effect libraries	176
About scene memories	125	Using an external head amp	177
Using scene memories	125	External head amp connections	177
Storing a scene	125	Remotely controlling an external head amp	178
Recalling a scene	128		
Using user-defined keys to recall	129	17. MIDI	181
Editing scene memories	130	MIDI functionality on the M7CL	181
Sorting and renaming scene memories	130	Basic MIDI settings	182
Scene memory editing	132	Using program changes	
Copying/pasting a scene	132	to recall scenes and library items	184
Clearing a scene	133	Using control changes to control parameters	187
Cutting a scene	134	Using parameter changes	
Inserting a scene	134	to control parameters	189
Using the Focus function	135		
Using the Recall Safe function	136	18. User settings (Security)	191
Using the Fade function	139	User Level settings	191
		User types and user authentication keys	191
13. Monitor/Cue	141	Setting the Administrator password	192
About the monitor/cue functions	141	Creating a user authentication key	193
Using the Monitor function	142	Logging-in	193
Using the Cue function	145	Changing the password	195
About cue groups	145	Editing a user authentication key	196
Operating the Cue function	146	Changing the user level	196
		Preferences	198
		User-defined keys	200

Console lock 201
 Locking the console 201
 Unlocking the console 201
Using a USB storage device to save/load data.... 202
 Saving the M7CL's internal data
 on a USB storage device 202
 Loading a file from a USB storage device 203
 Editing the files saved
 on a USB storage device 203
 Formatting media on
 a USB storage device 206

19. Other functions **207**

About the SETUP screen 207
Word Clock and Slot settings..... 208
Using cascade connections 210
 Operations on the cascade slave M7CL..... 210
 Operations on the cascade master M7CL 211
Basic settings
 for MIX buses and MATRIX buses..... 212
Setting the date and time of the internal clock.... 213
Setting the network address 214
Specifying the brightness
 of the touch screen, LEDs, and lamps..... 215
Initializing the M7CL's internal memory..... 216
Adjusting the detection point
 of the touch screen (Calibration function) 217
Adjusting the faders (Calibration function) 218
Adjusting the input/output gain
 (Calibration function)..... 219

Appendices **221**

EQ Library List 221
DYNAMICS Library List 222
Dynamics Parameters 225
Effect Type List 228
Effects Parameters 229
Effects and tempo synchronization 240
Scene Memory/Effect Library
 to Program Change Table..... 241
Parameters that can be assigned
 to control changes 245
Control change parameter assignments 247
NRPN parameter assignments 249
Mixing parameter operation applicability 252
Functions that can be assigned
 to user-defined keys 253
MIDI Data Format 255
Warning/Error Messages 262
Troubleshooting 264
General Specifications 265
Input/output characteristics 266
Electrical characteristics 268
Other Functions 269
Pin Assignment..... 270
Dimensions 271
Installing the MBM7CL meter bridge (option) 272
MIDI Implementation Chart 273
Index 274
Block Diagram..... End of Manual
Level Diagram End of Manual

- The illustrations and screen displays as shown in this Owner's manual are for instructional purposes only, and may be different from the ones on your device.
- Centralogic is trademark of Yamaha Corporation.
- The company names and product names in this Owner's Manual are the trademarks or registered trademarks of their respective companies.

◆ Chapter 1 ◆

Introduction

Thank you

Thank you for purchasing the Yamaha M7CL digital mixing console. In order to take full advantage of the M7CL's superior functionality and enjoy years of trouble-free use, please read this manual before you begin using the product. After you have read the manual, keep it in a safe place.

An overview of the M7CL

The M7CL is a digital mixing console with the following features.

■ A mixing system that delivers both cutting-edge digital technology and analog-style operation —

The M7CL is a full-digital mixing console containing the latest digital technology, designed for installed systems or SR applications. 24-bit linear AD/DA converters are used to deliver up to 108 dB of dynamic range and amazing sound quality.

As input channels, it provides 32 (M7CL-32 model) or 48 (M7CL-48 model) monaural INPUT channels, and four stereo ST IN channels.

As output channels, it provides 16 MIX channels, eight MATRIX channels, a STEREO channel, and a MONO channel. L/C/R three-channel output using the STEREO/MONO channels is also supported.

The user interface has been completely redesigned for simple and intuitive operation.

A dedicated channel strip with fader, cue, and on/off control is provided for all frequently-used input channels and the STEREO/MONO channels. This mixer can be comfortably operated even by users who are new to digital consoles.

The SELECTED CHANNEL section located at the left of the display lets you use the knobs to control the main parameters (gain, EQ, dynamics threshold, bus send levels, etc.) for the particular channel on which you're focusing. This section can be operated just like a module on an analog mixer.

In the center of the top panel is located the newly developed Centralogic section, which lets you control eight channels at once. You can control fader, cue, and on/off settings for the eight channels or DCA groups recalled to this section by pressing a single key. The display is a touch screen. You can turn functions on/off or select items simply by touching buttons or knobs in the screen.

Mix parameter settings, including head amp gain and phantom power for input channels, can be stored and recalled as "scenes." All faders on the panel are motorized moving faders, so that when you recall a scene, the previous fader locations are reproduced immediately.

■ Effects and graphic EQ that can be patched into a desired signal path —

High-quality multi-effect processors are built in, with up to four available simultaneously. Effects such as reverb, delay, multiband compression, and various modulation effects can be routed via internal buses or inserted into the desired channel. 31-band graphic EQ and a newly developed Flex15GEQ are also provided, and can be inserted in any channel or output.

The Flex15GEQ allows you to adjust the gain for any fifteen of the thirty-one bands.

Since two GEQ units can be mounted in the same rack, a total of up to sixteen GEQ units can be used simultaneously. To use effects or graphic EQ, you mount them in the eight virtual racks shown in the touch screen. The currently-mounted modules can be seen at a glance, and you can switch modules and change input/output patching in an intuitive manner.

■ Cascade connections in the digital domain

A second M7CL unit or a digital mixer such as the Yamaha PM5D connected via a digital I/O card installed in a slot can be cascade-connected in the digital domain. Of the MIX buses, MATRIX buses, STEREO/MONO buses, and CUE bus, up to twenty-four buses can be cascaded individually.

■ Security functions that can be specified at user-level or system-level

The available functionality can be restricted for users other than the administrator, with three levels of security; Administrator, Guest, and User. Passwords can be specified for the administrator and users, preventing important settings from being changed accidentally. Information specific to each user (user level, system settings, and user-defined key settings) can be stored on a USB storage device as a “user authentication key.” By loading your own user authentication key from a USB storage device, you can instantly set up the ideal operating environment for yourself.

■ I/O card expansion

The rear panel provides three slots in which separately sold mini-YGDAI cards can be installed. AD cards, DA cards, or digital I/O cards can be installed in these slots to add inputs and outputs. If an external head amp unit (such as the Yamaha AD8HR) that supports a special protocol is connected to the REMOTE connector, the phantom power and gain settings of the external head amp can also be remotely controlled from the M7CL.

Differences between the M7CL-48 and M7CL-32

The M7CL is available in two models; the M7CL-48 and the M7CL-32. These models differ as follows.

■ M7CL-48

This model provides 48 INPUT jacks and 48 INPUT channels.

INPUT jacks 1–32 are located at the right side of the rear panel, and INPUT jacks 33–48 are located at the left side of the rear panel.

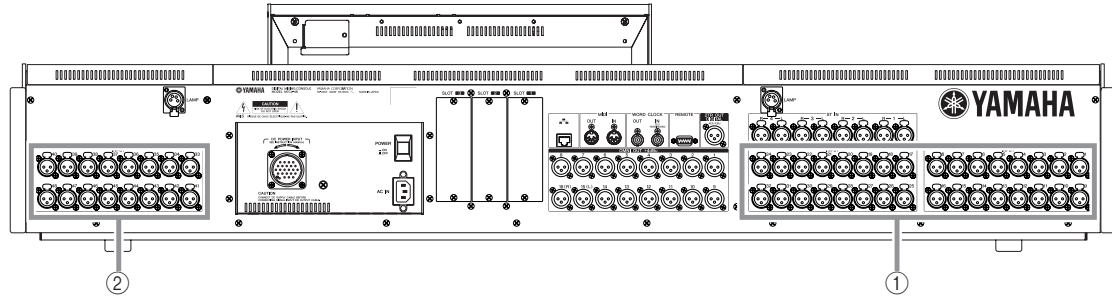

- ① INPUT jacks 1–32
- ② INPUT jacks 33–48

In addition to the channel strip for INPUT channels 1–32 located at the left side of the front panel, there is a channel strip for INPUT channels 33–48 located at the right side of the front panel.

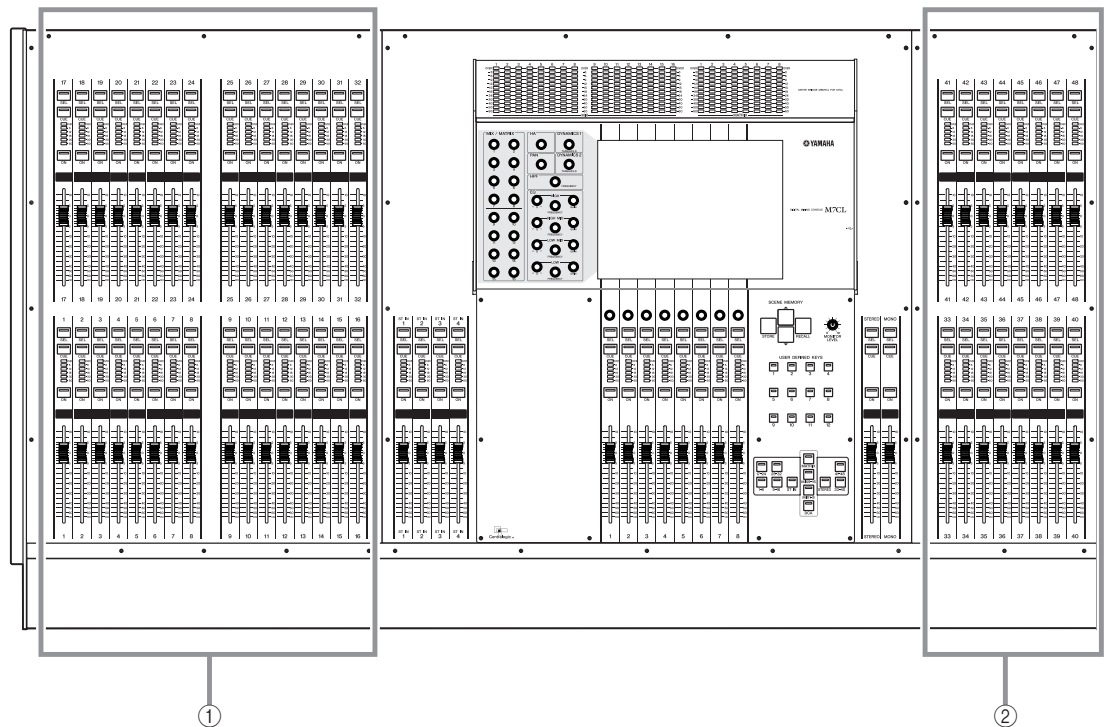

- ① Channel strip for INPUT channels 1–32
- ② Channel strip for INPUT channels 33–48

■ M7CL-32

This model provides 32 INPUT jacks and 32 INPUT channels.

INPUT jacks 1–32 are located at the right side of the right panel, just as on the M7CL-48 model, but there are no INPUT jacks at the left side of the rear panel.

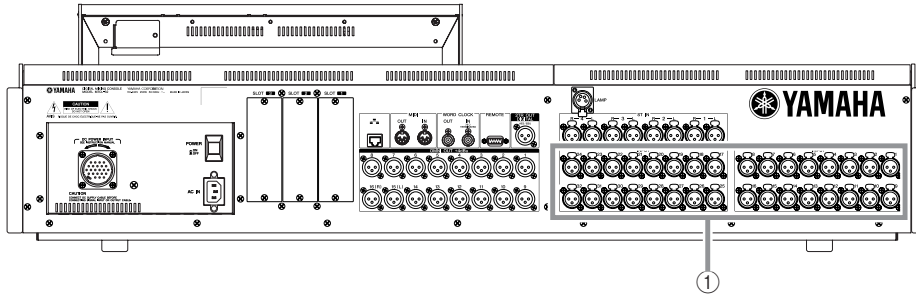

① INPUT jacks 1–32

The channel strip for INPUT channels 1–32 is located in the left side of the front panel, just as on the M7CL-48 model, but there is no channel strip for INPUT channels in the right side.

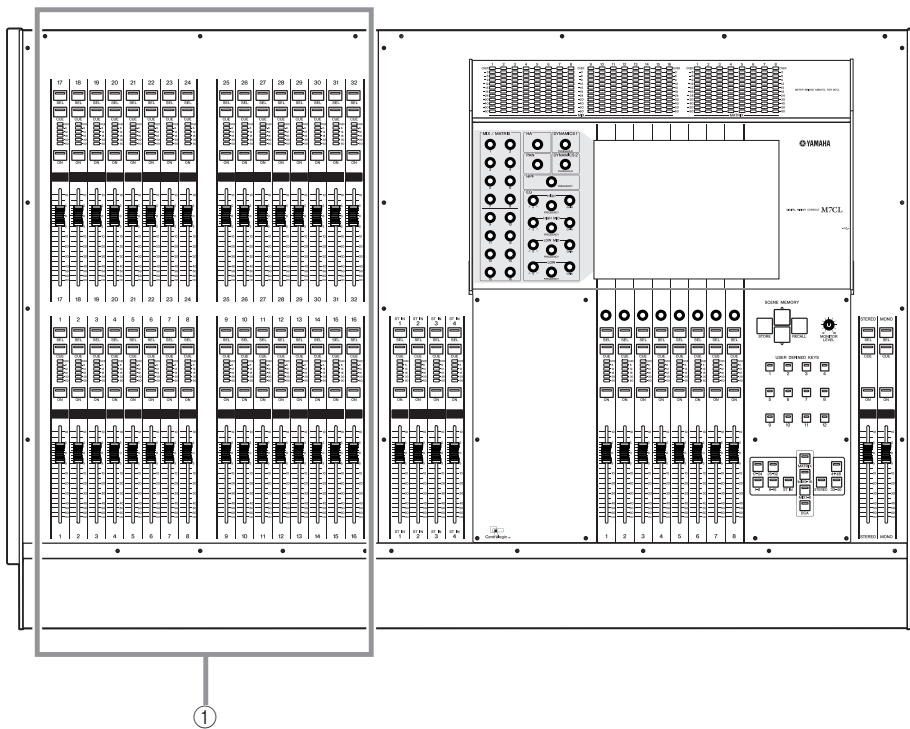

① Channel strip for INPUT channels 1–32



- In this owner's manual, whenever there is a difference between the M7CL-32 model and the M7CL-48 model, specifications that apply only to the M7CL-48 model are enclosed in curly brackets { } (e.g., INPUT jacks 1–32 {1–48}).

The M7CL's channel structure

The M7CL provides the following input channels and output channels.

■ Input channels

This section processes an input signal and sends it to various buses (STEREO, MONO, MIX, MATRIX). There are two types of input channel, as follows.

● INPUT channels 1–32 {1–48}

These channels are used to process monaural signals. By default, the input signals from the monaural analog input jacks (INPUT jacks 1–32 {INPUT jacks 1–48}) are assigned to these channels.

● ST IN channels 1–4

These channels are used to process stereo signals. By default, the input signals from EFFECT RETURN 1–4 are assigned to these channels.

Signal assignments to the input channels can be changed as desired.

■ Output channels

This section mixes the signals sent from input channels etc., and sends them to the corresponding output ports or output buses. There are three types of output channel, as follows.

● MIX channels 1–16

These channels process the signals sent from input channels to the MIX buses, and send them from the output ports. These are used mainly to send signals to the monitor system or to external effects. The signals of MIX channels 1–16 can also be sent to the STEREO bus, MONO bus, or MATRIX buses.

When the M7CL is in the default state, the following output ports are assigned.

MIX channels 1–12	OMNI OUT jacks 1–12
MIX channels 1–8	Slot 1 output channels 1–8, 9–16
MIX channels 9–16	Slot 2 output channels 1–8, 9–16

● MATRIX channels 1–8

These channels process the signals that are sent from input channels, MIX channels, STEREO channel, and MONO channel to the MATRIX buses, and send them from the output ports. Using the STEREO and MONO buses, different combinations of signals and mix balances can be sent out from the M7CL.

When the M7CL is in the default state, the following output ports are assigned.

MATRIX channels 1/2	OMNI OUT jacks 13/14
MATRIX channels 1–8	Slot 3 output channels 1–8, 9–16

● STEREO channel / MONO channel

These channels process the signals that are sent from the input channels or MIX channels, and send them to the corresponding output port. These channels are used as the main stereo output and monaural output.

The STEREO channel and MONO channel can be used either to output independent signals, or for three-channel L/C/R playback.

When the M7CL is in the default state, the following output ports are assigned.

STEREO channel L	OMNI OUT jack 15, 2TR OUT DIGITAL jack L
STEREO channel R	OMNI OUT jack 16, 2TR OUT DIGITAL jack R
MONO channel	No assignment

Signal assignments to the output channels can be changed as desired.

About the MIX bus types (VARI / FIXED)

The sixteen MIX buses provided on the M7CL can be assigned either as VARI or FIXED types in pairs of adjacent odd-numbered/even-numbered buses (→ p. 212). Each type has the following characteristics.

● VARI

This type allows the send level of the signal sent from the input channels to the MIX bus to be varied. The point at which the signal is sent from the input channel to a VARI type MIX bus can be chosen from before the EQ, before the fader, or after the [ON] key. This type is used mainly for sending the signal to a monitor system or external effect.

● FIXED

With this type, the send level of the signal sent from the input channels to the MIX bus is fixed. The signal sent from an input channel to a FIXED type MIX bus is taken from immediately after the [ON] key. This type is used mainly when you want to distribute signals to an external device at the same mix balance as the STEREO/MONO buses.

About word clock

“Word clock” refers to the clock that provides the basis of timing for digital audio signal processing.

Normally, one device transmits a reference word clock signal, and the other devices receive this word clock signal and synchronize to it.

In order to transmit or receive digital audio signals to or from an external device via a digital I/O card installed in a slot of the M7CL, the word clock must be synchronized between the devices. Be aware that if the word clock is not synchronized, the signal will not be sent correctly, or there may be unpleasant noise. (For details on synchronizing the M7CL’s word clock with an external device → p. 208).

Conventions in this manual

In this manual, switch-type controls on the panel are called “keys.” Of the control knobs on the panel, those that turn from a minimum value to a maximum value are called “knobs,” while those that turn endlessly are called “encoders.”

Controls located on the panel are enclosed in square brackets [] (e.g., [CUE] key) in order to distinguish them from the virtual buttons and knobs displayed in the screen. For some controls, the name of the section is given before the [] (e.g., SCENE MEMORY [STORE] key).

Whenever there is a difference between the M7CL-32 model and the M7CL-48 model, specifications that apply only to the M7CL-48 model are enclosed in curly brackets { } (e.g., INPUT jacks 1–32 {1–48}).

About the firmware version

You can view the firmware version number in the SETUP screen (→ p. 207).

You can also download the most recent firmware version from the website.

<http://www.yamahaproaudio.com/>

◆ Chapter 2 ◆

Panels and controls

2

Panels and controls

This chapter explains the names and functions of each part of the M7CL.

Top panel

The top panel of the M7CL is divided into the following sections.

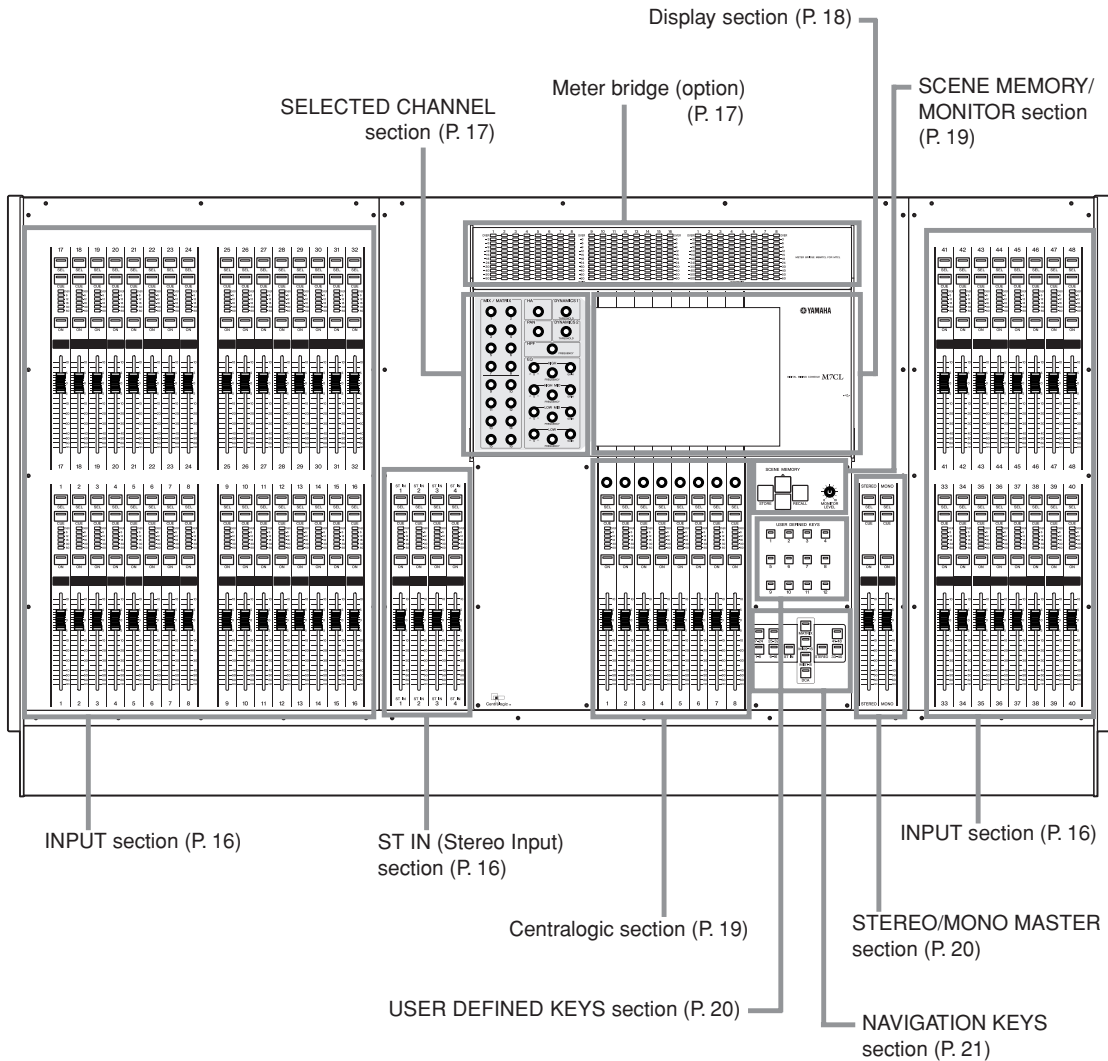

NOTE

- This illustration shows the top panel of the M7CL-48. The M7CL-32 does not have the INPUT section at the right (channels 33–48).

INPUT section

In this section you can control the main parameters of monaural input channels 1–32 {1–48}.

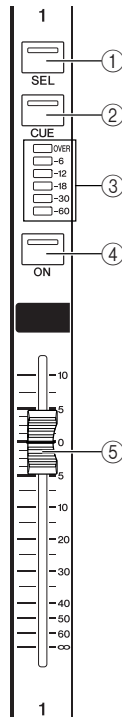

① [SEL] key

These keys select the channel to be controlled. When you press this key to make the LED light, that channel will be selected for control in the SELECTED CHANNEL section and in the touch screen.

In SENDS ON FADER mode, the [SEL] keys of all channels will light.

② [CUE] key

These keys select the channel to be cue-monitored. If cue is on, the LED will light.

③ Meter LEDs

These LEDs indicate the input level of the channel.

ST IN (Stereo Input) section

In this section you can control the principal parameters for the stereo ST IN channels 1–4. With the exception that the object of control will alternate between the L and R channels each time you press the [SEL] key, these controls operate in the same way as for the INPUT channels.

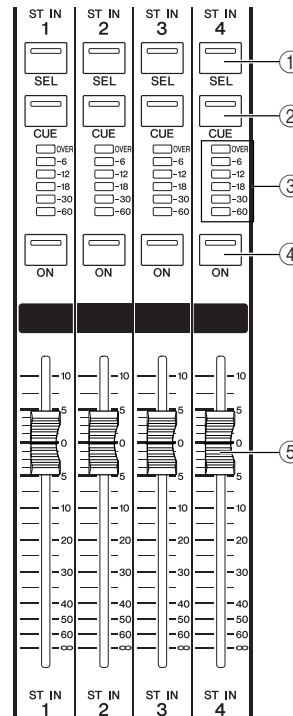

④ [ON] key

This switches the channel on/off. If a channel is on, the key LED will light. In SENDS ON FADER mode, this is an on/off switch for the signal sent from each channel to the currently selected MIX bus.

⑤ Fader

Adjusts the input level of the channel. In SENDS ON FADER mode, this adjusts the send level of the signal from each channel to the currently selected MIX bus.

■ Meter bridge (option)

If an optional MBM7CL meter bridge is installed, the MIX/MATRIX channel levels can be monitored at all times. The monitoring position can be selected from PRE EQ (immediately before attenuator), PRE FADER (immediately before the fader), or POST ON (immediately after the [ON] key).

① MIX meters

These indicate the level of MIX channels 1–16.

② MATRIX meters

These indicate the level of MATRIX channels 1–8.

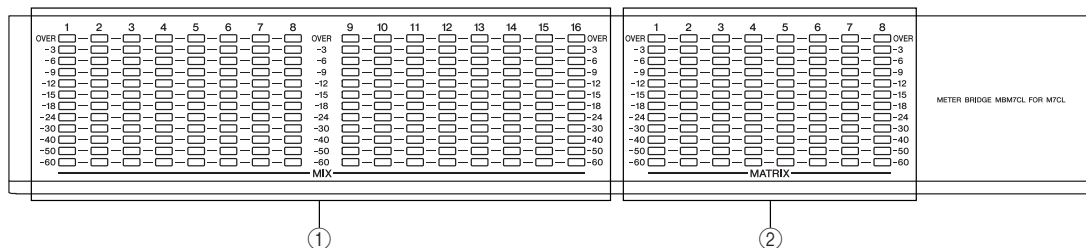

■ SELECTED CHANNEL section

In this section you can control the mix parameters for the currently selected input channel or output channel.

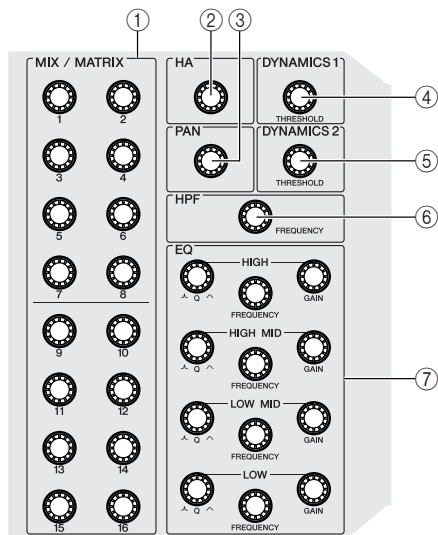

① [MIX/MATRIX] encoders

● When an input channel is selected

This adjusts the send level of the signal sent from that channel to the MIX/MATRIX buses.

● When a MIX channel is selected

This adjusts the send level of the signal sent from the selected MIX channel to the MATRIX buses.

● When a MATRIX channel is selected

This adjusts the send level of the signal sent from each MIX channel to the selected MATRIX bus.

② [HA] encoder

Adjusts the head amp gain of an input channel. This does nothing if another type of channel is selected.

NOTE

- The PAD will be internally switched on or off when the HA gain is adjusted between -14 dB and -13 dB. Keep in mind that noise may be generated if there is a difference between the Hot and Cold output impedance of the external device connected to the INPUT connector when using phantom power.

③ [PAN] encoder

● When an input channel is selected

This adjusts the panning of the signal that is sent from the selected channel to the L/R channels (or L/C/R channels) of the STEREO bus.

● When a ST IN channel is selected

This adjusts the left/right balance of the signals that are sent from the selected two channels to the STEREO bus.

● When a MIX channel (MONO x 2) is selected

This adjusts the panning of the signal that is sent from the selected channel to the L/R channels of the STEREO bus.

● When a MIX channel (STEREO) is selected

This adjusts the left/right balance of the signals that are sent from the selected two channels to the STEREO bus.

● When a MATRIX channel (STEREO) is selected

This adjusts the left/right balance of the signals that are sent from the selected two channels to the STEREO bus.

● When a STEREO channel is selected

This adjusts the left/right balance of the signals that are output from the L/R channels of the STEREO bus.

④ [DYNAMICS 1] encoder

● When an input channel is selected

Adjusts the THRESHOLD parameter of the gate, etc.

● When a MIX, MATRIX, or STEREO/MONO channel is selected

Adjusts the THRESHOLD parameter of the compressor, etc.

⑤ [DYNAMICS 2] encoder

● When an input channel is selected

Adjusts the THRESHOLD parameter of the compressor, etc.

● When a MIX, MATRIX, or STEREO/MONO channel is selected

No function.

⑥ [HPF] encoder

Adjusts the HPF cutoff frequency for an input channel. This does nothing for other types of channel.

⑦ EQ [Q], EQ [FREQUENCY], EQ [GAIN] encoders

For each band of the four-band EQ, these adjust the Q, center frequency (cutoff frequency), and gain.

■ Display section

This is a touch screen that you can operate by touching the surface of the screen. A USB connector is provided on the right side of the display.

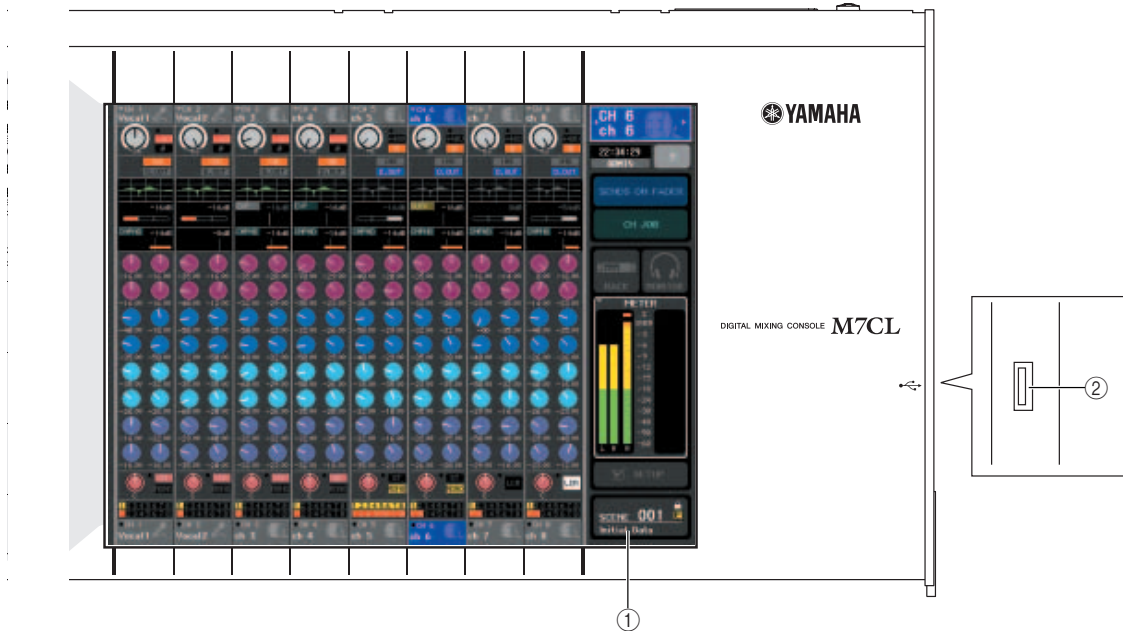

① Display (touch screen)

This display shows the information you need to operate the M7CL, and lets you make system-wide settings and control mix parameters for input and output channels. Since this is a touch screen, you can use your finger on the screen to select menus or set parameters. However, you cannot press two or more locations to operate them simultaneously.

NOTE

- If the touch screen becomes dirty, wipe it with a soft dry cloth.

⚠ CAUTION

- Never use a sharp or pointed object such as your fingernail to operate the touch screen. Doing so may scratch the screen and render the touch screen inoperable.

② USB connector

You can connect a USB storage device here to save/load internal data. USER KEY data that determines the user level can be saved on a USB storage device to limit the functionality that can be operated by each user.

NOTE

- You can connect a USB storage device to the USB connector. However, operation is guaranteed only with USB flash memory.

■ USB storage device formats

Storage media with capacities 2GB or less formatted in FAT12, FAT16, or FAT32 are supported. If your storage device is formatted otherwise, please re-format it in the SAVE/LOAD screen.

■ Prevention of accidental erasure

Some USB storage devices have a write protect setting that lets you prevent data from being erased accidentally. If your storage device contains important data, it's a good idea to use the write protect setting to prevent accidental erasure.

On the other hand, you'll need to make sure that your USB storage device's write protect setting is turned off before you save data.

⚠ CAUTION

- An ACCESS indicator is shown in the function access area while data is being accessed (saved, loaded, or deleted). Do not disconnect the USB connector or power-off the M7CL while this indicator is shown. Doing so may damage your storage media, or may damage the data in the M7CL or on your media.

Centralogic section

In this section you can control a group of (up to) eight channels or DCA groups selected in the NAVIGATION KEYS section.

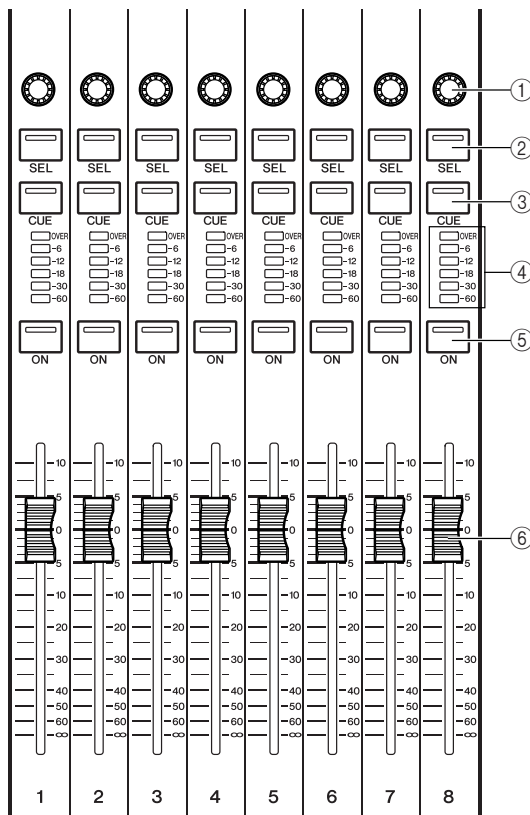

① Multi-function encoders

According to the type of screen that is currently selected, these encoders control the knobs selected in the touch screen.

② [SEL] key

These keys select the channel to be controlled. When you press this key to make the LED light, that channel will be selected for control in the SELECTED CHANNEL section and in the touch screen.

③ [CUE] key

These keys select the channel to be cue-monitored. If cue is on, the LED will light.

④ Meter LEDs

These LEDs indicate the input/output level of the channel.

⑤ [ON] key

This switches the channel on/off. If a channel is on, the key LED will light.

⑥ Fader

This adjusts the input/output level of the channel. You can also make internal settings (→ p. 163) so that these faders are used as controllers to adjust the gain of each GEQ band.

2

Panels and controls

SCENE MEMORY/MONITOR section

In this section you can perform operations for scene memory and monitoring.

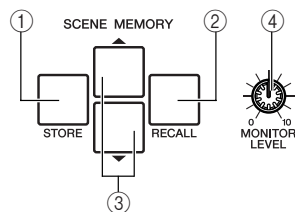

① SCENE MEMORY [STORE] key

This key stores the current mix parameter settings into a dedicated scene memory.

② SCENE MEMORY [RECALL] key

This key recalls previously-saved settings from a scene memory.

③ SCENE MEMORY [▲]/[▼] keys

Use these keys to select the scene number that you want to store or recall. The number of the currently selected scene is shown in the function access area in the right of the touch screen. You can press the [▲]/[▼] keys simultaneously to return to the current scene number.

④ [MONITOR LEVEL] knob

Adjusts the signal level of the monitor output. If the PHONES LEVEL LINK function is turned on in the MONITOR screen, this will also adjust the level of the front panel [PHONES] jack.

■ USER DEFINED KEYS section

These keys execute the functions that have been assigned by the user.

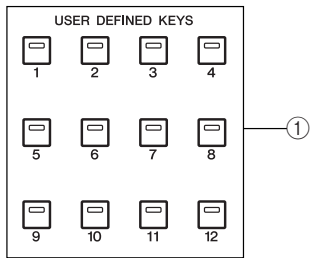

① User defined keys [1]–[12]

These keys execute the functions that have been assigned by the user (scene changes, switching the talkback or internal oscillator on/off, etc.).

■ STEREO/MONO MASTER section

In this section you can control the principal parameters of the STEREO/MONO channels.

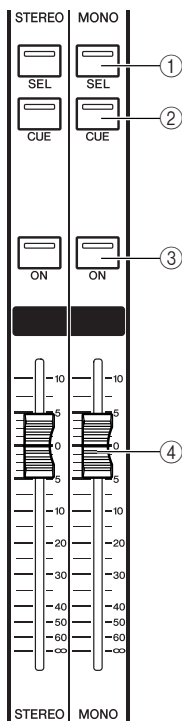

① [SEL] key

This key selects the channel to be controlled. When you press this key to make the LED light, that channel will be selected for control in the SELECTED CHANNEL section and in the touch screen.

For the STEREO channel, the selected object of control will alternate between the L and R channels each time you press the [SEL] key.

② [CUE] key

This key selects the channel to be cue-monitored. If cue is on, the LED will light.

③ [ON] key

This key switches the channel on/off. If a channel is on, the key LED will light.

④ Fader

This adjusts the output level of the channel.

NAVIGATION KEYS section

In this section you can select the channels that will be controlled by the Centralogic section and in the touch screen.

NOTE

- If you press and hold a navigation key for two seconds or longer, that key will blink. At this time, only the object of control for the Centralogic section will be changed to the corresponding channels and fixed. If you press a different navigation key while the first key is blinking, only the object of control in the touch screen will be changed.

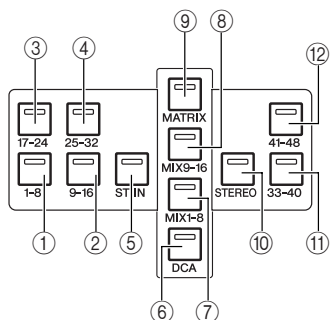

- ① **[IN 1-8] key**
 - ② **[IN 9-16] key**
 - ③ **[IN 17-24] key**
 - ④ **[IN 25-32] key**
- These keys select INPUT channels 1–8, 9–16, 17–24, and 25–32 respectively.

- ⑤ **[ST IN] key**
This key selects ST IN channels 1–4.
- ⑥ **[DCA] key**
This key selects the DCA groups.
- ⑦ **[MIX 1-8] key**
- ⑧ **[MIX 9-16] key**
These keys select MIX channels 1–8 and 9–16 respectively.
- ⑨ **[MATRIX] key**
This key selects MATRIX channels 1–8.
- ⑩ **[STEREO] key**
This key assigns the STEREO channel L/R and the MONO channel to modules 1–3 of the Centralogic section. In this case, modules 4–8 are not used.
- ⑪ **[IN 33-40] key {M7CL-48 only}**
- ⑫ **[IN 41-48] key {M7CL-48 only}**
These keys select INPUT channels 33–40 and 41–48 respectively.

Rear panel

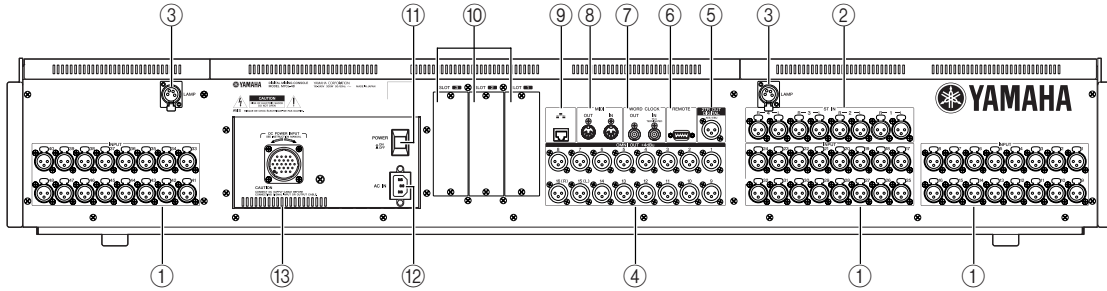

M7CL-48

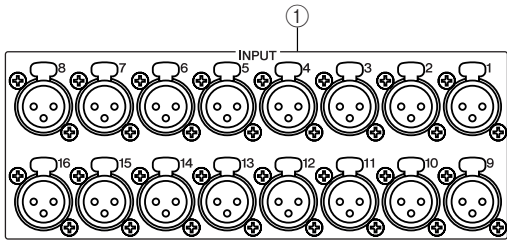

① INPUT jacks 1–32 {1–48}

These are balanced XLR-3-31 female input jacks for inputting analog audio signals from line level devices or microphones. Nominal input level is -62 dBu to +10 dBu.

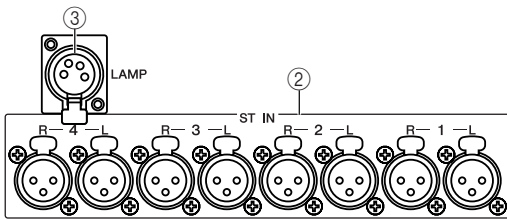
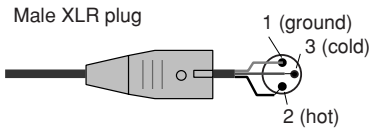

② ST IN jacks 1–4

These are balanced XLR-3-31 female input jacks for inputting analog audio signals from line level devices or microphones. Nominal input level is -62 dBu to +10 dBu.

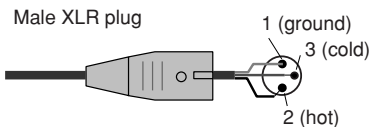

③ LAMP connector

This is a four-pin female XLR output jack that supplies power to a separately sold gooseneck lamp (such as the Yamaha LA5000). {The M7CL-48 has these connectors at two locations.}

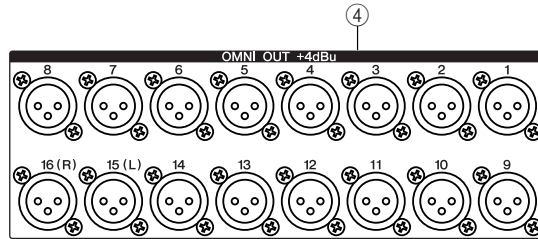

④ OMNI OUT jacks 1–16

These are XLR-3-32 male output jacks that output analog audio signals. These are used mainly to output the signals of MIX channels or MATRIX channels. Nominal output level is +4 dBu.

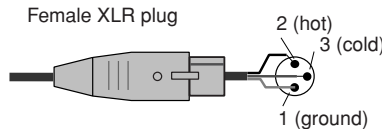

NOTE

• Although OMNI OUT jacks 1–16 have a nominal input/output level of +4 dBu (maximum level +24 dBu), an internal switch allows this to be changed to -2 dBu (maximum level +18 dBu) if necessary. (A fee will be charged for this procedure.) For details, contact to your Yamaha dealer.

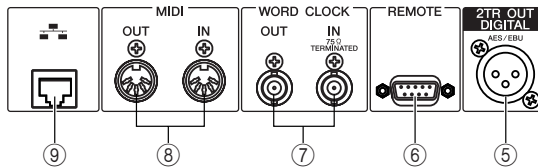

⑤ 2TR OUT DIGITAL jack

This is an AES/EBU (XLR-3-32 male) jack that outputs the digital audio signal of a desired channel in AES/EBU format. This is used mainly to output the signal of the STEREO/MONO channel.

⑥ REMOTE connector

This is a D-sub 9-pin male connector for remotely controlling an external head amp device (e.g., Yamaha AD8HR) that supports a special protocol. It can also be used to transmit/receive MIDI messages to/from an external device.

⑦ WORD CLOCK IN/OUT connectors

These are BNC connectors used to transmit/receive word clock signals to/from an external device. The WORD CLOCK IN connector is internally terminated by 75 ohms.

⑧ MIDI IN/OUT connectors

These connectors are used to transmit and receive MIDI messages to and from external MIDI devices. The MIDI IN connector receives messages from an external device, and the MIDI OUT connector transmits messages from the M7CL. These are used mainly to record M7CL parameter operations or scene/library selections on an external device, or to control M7CL parameters from an external device.

⑨ ETHERNET connector

This connector allows the M7CL to be connected via a CAT3 (transmission speed up to 10 Mbps) or CAT5 (transmission speed up to 100 Mbps) Ethernet cable to a Windows computer. This is used mainly to control mix parameters or edit scene memories and libraries from the dedicated “M7CL Editor” application program.

NOTE

- The DME Network Driver required for connection to the Ethernet connector, the Studio Manager required for starting up M7CL Editor, and the M7CL Editor itself can be downloaded from the following Yamaha website.

<http://www.yamahaproaudio.com/>

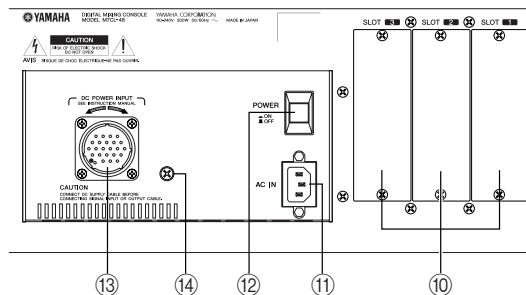

⑩ Slots 1–3

These slots allow separately sold mini-YGDAI I/O cards to be installed to expand the input/output ports.

⑪ AC IN connector

Connect the included power cable to this connector.

⑫ POWER switch

This switch turns the internal power supply on/off.

⑬ DC POWER INPUT connector

You can connect the separately sold PW800W power supply here as a backup external power supply. If the PW800W is connected, the M7CL will continue receiving power from the PW800W even if its own internal power supply shuts down due to a problem.

CAUTION

- If you connect the PW800W, you must be sure to first power-off both the M7CL and the PW800W. Then use the optional power supply cable (PSL360) to make the connection. Failure to observe this will cause malfunctions or electric shock.

HINT

- If the PW800W is connected, the M7CL will operate correctly whether its own internal power supply and the PW800W are both turned on, or whether just one of these is turned on.
- If both power supplies are on, and an abnormality is detected in one of the power supplies, the M7CL will automatically switch to the other power supply. If this occurs, the touch screen will show a message to indicate this.

⑭ Grounding screw

In order to ensure safe operation, use this screw to connect the M7CL to an electrical ground. Making a correct ground connection will effectively eliminate noise such as hum and interference.

Under the front pad

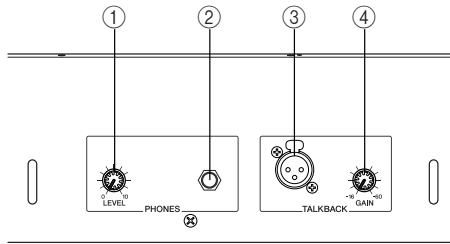

① **PHONES LEVEL knob**

Adjusts the level of the signal that is output from the PHONES OUT jack.

② **PHONES OUT (headphone output) jack**

This headphone jack lets you monitor the MONITOR OUT or CUE signal.

③ **TALKBACK jack**

This is a balanced XLR-3-31 jack to which a talkback mic can be connected. You can make settings in the screen to supply +48V phantom power to this jack. This is used to send instructions from the mixer operator to the desired output channel.

④ **TALKBACK GAIN knob**

This adjusts the input level of the mic connected to the TALKBACK jack.

◆ Chapter 3 ◆

Basic operation of the M7CL

This chapter explains the M7CL's user interface and its basic operations.

3

Basic operation of the M7CL

Basic operations in the top panel / touch screen

This section explains the basic procedures you can perform in the M7CL's top panel and touch screen. In general, you will operate the M7CL using the appropriate combination of the operations explained here.

Pressing the touch screen

Place your fingertip on a button, knob, or field in the touch screen, and press lightly. You will mainly use this operation to switch screens and pages, to select the parameter to be operated, and to turn a button on/off. Depending on the type of button, the number may increase or decrease depending on the location you press.

Multiple selection (specifying a range)

While pressing your finger on the touch panel, move it in the left/right direction to specify a range within a character string. You will use this mainly when assigning a name to a scene or library.

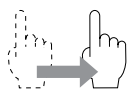

For the channel select buttons, you can select multiple buttons by moving your finger across the touch screen while continue to press.

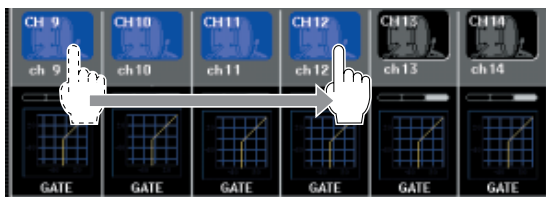

HINT

- This makes it easy to select a range of buttons to be turned on/off together.

Special operations for keys

Normally you will press a top panel key once, but in some cases you can access a special function by rapidly pressing a key twice in succession.

Encoder operations

Normally, encoders are turned left/right to change the value of the corresponding parameter. By pressing an encoder you can recall a specific screen. For some parameters, you can adjust the value in finer steps (greater detail) by turning the encoder while pressing it.

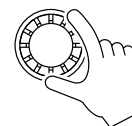
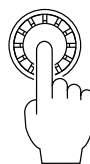

Multifunction encoder operations

Multifunction encoders 1–8 are used to operate the knobs selected for operation in the touch screen (→ p. 27). When you press to select a knob that can be controlled by the multifunction encoders, a thick line appears around it. (Normally, a knob of this type corresponds to the multifunction encoder located immediately below that knob, allowing you to control up to eight parameters simultaneously.) While a knob is selected, turning the multifunction encoder located immediately below that knob will change the value of the corresponding parameter. In the SCENE LIST screen, you can make a multiple selection by turning a multifunction encoder while pressing it.

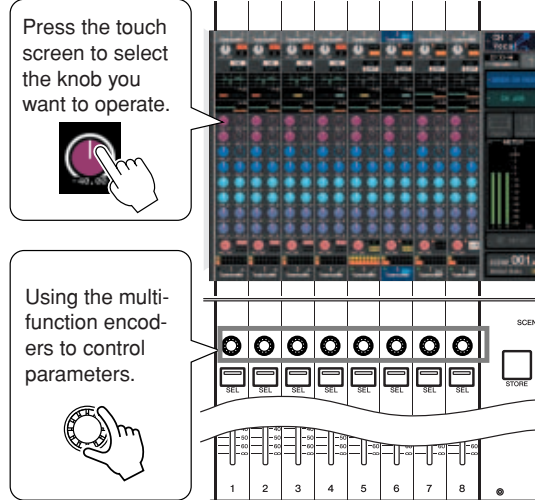

The on-screen user interface

Operations such as mixing and adjusting the sound of each channel are performed using the top panel faders, keys, and encoders. However to make more detailed settings, you will need to access the appropriate function and edit the parameter values in the touch screen. The section below explains the various user interface components shown in the touch screen, and how to use them.

Tabs

Some screens shown in the display consist of multiple pages. In screens of this type, the page name is shown at the top and bottom. The area of the display showing a page name is called a “tab.” Tabs are used to switch between pages within the same screen.

Buttons

Buttons in the display are used to execute specific functions, to switch parameters on/off, or to select one of multiple choices. Buttons that perform an on/off operation are shown in a color such as white, yellow, or green while turned on, and blue or black while they are turned off. When you press a button that has a ▼ symbol, a separate window will open, allowing you to make detailed settings.

Faders / Knobs

Faders in the screen are used mainly for visual confirmation of the levels of the corresponding channels, and will move in tandem when you operate the top panel faders. The current value is also shown in numerical form immediately below the fader.

Knobs in the screen provide visual confirmation of the value of the corresponding parameter.

Most knobs are linked with operations of the SELECTED CHANNEL section encoders or the multifunction encoders. The current value is also shown in numerical form immediately below the knob.

When a knob that can be operated by the multifunction encoders (i.e., knobs other than in the SELECTED CHANNEL VIEW screen) is pressed once, a heavy frame appears around the knob. This frame indicates that the knob is selected for operation using the multifunction encoders.



While you are using the multifunction encoders to operate a knob, the line indicating the setting of the knob will become longer and the line around the circumference will become thinner; this clearly identifies the knob that you are operating. Also, a frame will appear around the numerical value.



Knobs for which a double frame is displayed indicate PAN/BALANCE.

HINT

- For some knobs, pressing them again when they are enclosed by a heavy frame will open a window where you can make additional detailed settings.

List windows

The following type of window will appear when you need to select items from a list, such as a list of user-defined keys.



Within the list, the highlighted item always shown in the center is the item selected for operations. Press the ↑/↓ located below the list to scroll the list upward or downward.

HINT

- You can also scroll up/down using the multifunction encoder.
- If there is more than one list in the screen, your operations will apply to the list enclosed in a yellow frame. You can press the multifunction encoder to move the focus of your operations to the next column.

Keyboard window

The following keyboard window will appear when you need to assign a name or comment to a scene or library, or when you need to assign a channel name. Press characters in the window to enter the desired characters (for the procedure see → p. 30).



3

Basic operation of the M7CL

Popup windows

When you press a button or field for a specific parameter in a screen, a window showing detailed parameters or lists will appear. This type of window is called a “popup window.”



There are three types of popup window, “1 ch” windows that show only a specific channel, “8 ch” windows that show the currently selected group of eight channels, and “ALL” windows that show all channels in a single view. You can switch between these using tabs.

Some popup windows show several buttons called “tool buttons” at the top of the window. You can use these tool buttons to recall libraries or to perform copy/paste operations.

Press the “X” symbol to close the popup window and return to the previous screen.

Dialog boxes

A dialog box like the following will appear when you need to confirm the operation you just performed.



Press the OK button to execute the operation. The operation will be cancelled if you press the CANCEL button.

Viewing the touch screen

The M7CL's touch screen shows the following information, and is broadly divided into two areas.



Function access area

① Selected channel

This shows the number, name and icon of the channel that is currently selected for operation. (For details on assigning a name → p. 30, on selecting an icon → p. 53). You can also press this field to switch channels. Pressing the left half will select the preceding channel, and pressing the right half will select the next channel.

② Time

This indicates the current time. (For details on how to set the time → p. 213).

③ User name

This indicates the name of the user who is currently logged in (i.e., is authenticated and able to operate the system).

If the oscillator or talkback is enabled, this area will indicate “OSC” or “TB” respectively. If cue monitor is on, the type of signal being cue-monitored (IN/OUT/DCA/KEY IN/EFFECT) is shown. An indication of “ACCESS” is shown while a USB storage device attached to the USB connector is being accessed.

NOTE

- Do not disconnect the USB connector while the “ACCESS” indication is shown here. Doing so may damage the data on the USB storage device.

④ Help

This button is used to show on-line help in the main area. However, the current software as of September 2005 does not support this.

⑤ SENDS ON FADER

Press this button to switch to SENDS ON FADER mode, where you can use the faders of the top panel to adjust the MIX send level (→ p. 64). During this time, the function access area of the touch screen will change to a screen allowing you to select the send-destination MIX bus.

⑥ CH JOB (Channel Job)

Press this button to switch to CH JOB mode, where you can make settings for channel grouping and linking (→ p. 113). During this time, the function access area of the touch screen will change to a screen allowing you to select the function you want to operate.

⑦ RACK

When you press this button, the VIRTUAL RACK screen will appear in the main area, allowing you to edit the GEQ or effect settings (→ p. 158).

⑧ MONITOR

When you press this button, the MONITOR screen will appear in the main area, allowing you to edit the monitor or oscillator settings (→ p. 142).

⑨ METERS

These are level meters that monitor the level of the STEREO bus (L/R), MONO bus (M), and cue signal (CUE). When you press this field, the METER screen will appear in the main area, displaying the meters and fader status for all channels at once (→ p. 153).

⑩ SETUP

When you press this button, the SYSTEM screen will appear in the main area, allowing you to make basic system settings and user-specific settings (→ p. 207).

⑪ SCENE

This indicates the number and name of the scene that was last stored or recalled. A lock icon is displayed for read-only scenes. If you edit the parameters from their last stored or recalled state, an “E” symbol will appear in the lower right.

When you press this field, the SCENE LIST screen will appear in the main area, allowing you to store or recall scenes (→ p. 125).

When you press a button ⑦ through ⑪ to access the corresponding screen, the button will be highlighted. In this state, pressing the button once again will return either to the most recently recalled SELECTED CHANNEL VIEW screen or the OVERVIEW screen.

Main area

The contents of the main area will change depending on the function that is currently selected. Mixing operations will involve mainly the following two types of screen.

■ SELECTED CHANNEL VIEW screen

This screen shows all the mix parameters for the currently selected channel. To access this screen, click one of the encoders of the SELECTED CHANNEL section.

**■ OVERVIEW screen**

This screen simultaneously shows the main parameters for the (up to) eight channels currently assigned to the Centralogic section. To access this screen, press one of the keys in the NAVIGATION KEYS section or one of the multi-function encoders.

**HINT**

- If the METER screen is shown in the meter area, the OVERVIEW screen won't appear even you press a key in the NAVIGATION KEYS section. To return to the OVERVIEW screen, press a multi-function encoder or press the highlighted METER field once again.

3

Basic operation of the M7CL

Entering names

On the M7CL you can assign a name to each input channel, output channel, and DCA group, and assign a title to scene and library data when saving it.

To assign a name, you will use the keyboard window shown in the screen.

1 Access the screen for assigning a name.

The illustration shown below is an example of the SCENE STORE window used to enter a scene title or comment.



The box that shows the characters you've entered will display a vertical line called the "cursor," which indicates the current position.

2 Use the keyboard window in the touch screen to enter the desired characters.

When you press a character in the keyboard window, the corresponding character will be entered in the box, and the cursor will move to the right.

3 Input the subsequent characters in the same way.

When inputting characters, you can use the following buttons in the keyboard window.

- **COPY button**
Copies the string of characters that are selected (highlighted) in the text box.
- **CUT button**
Deletes and copies the string of characters that are selected (highlighted) in the text box.
- **PASTE button**
Inserts the string of characters copied by COPY or CUT at the cursor location (or overwrites the currently selected range of characters).
- **CLEAR button**
Deletes all characters that have been input in the text input box.
- **INS button**
Inserts a space (blank) at the cursor position.
- **DEL button**
Deletes the character at the right of the cursor (or the string of characters selected in the text box).

- **BS button**
Deletes the character at the left of the cursor (or the string of characters selected in the text box).
- **TAB button**
This button accesses the next selectable item. For example in the SCENE STORE window you can use this button to switch between two text input boxes, and in the PATCH/NAME window you can use this to switch channels.
- **SHIFT LOCK button**
Switches between uppercase and lowercase alphabetical characters. You can enter uppercase characters and symbols while this button is on, and lowercase characters and numerals while this button is off.
- **ENTER button**
Finalizes the name you entered. In the SCENE STORE window, this has the same effect as pressing the STORE button.

4 When you've entered the name, press the STORE button or the ENTER button.

The name you entered will be applied.



- This basic procedure also applies in screens where you enter names for channels or other library items. When you enter a name for a channel, your input will be reflected immediately without your having to press the ENTER button.
- By pressing inside the text entry box, you can move the input position to the location you pressed. If you select a region of characters you've entered in the box and then enter a new character, the newly entered character will overwrite the selected region.

Using the tool buttons

In some popup windows, the title bar at the top of the window contains tool buttons for additional functions. You can use these buttons to access related libraries or copy parameters from one channel to another channel. This section explains how to use the tool buttons.

About the tool buttons

In the ATT/HPF/EQ, DYNAMICS 1/2, GEQ, and EFFECT popup windows, the following tool buttons are shown.

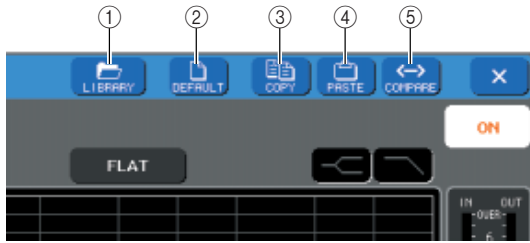

① LIBRARY button

This button opens the library associated with the current popup window (EQ, dynamics, GEQ, or effect libraries).

② DEFAULT button

This button returns the currently selected channel (EQ/dynamics) or rack (effect) to its default state.

③ COPY button

This button copies the settings of the currently selected channel (EQ/dynamics) or rack (GEQ/effect). The copied content is held in a buffer memory (a temporary memory area).

④ PASTE button

This button pastes the settings from the buffer memory to the currently selected channel (EQ/dynamics) or rack (GEQ/effect).

⑤ COMPARE button

This button exchanges and compares the settings in the buffer memory with the settings of the currently selected channel (EQ/dynamics) or rack (GEQ/effect).

For some windows, the following tool buttons are also shown.

- **SET ALL**Sets all parameters in the window.
- **CLEAR ALL**....Clears all parameters in the window.
- **ALL PRE**.....Specifies PRE as the position from which all signals are sent to the specified bus.
- **ALL POST**Specifies POST as the position from which all signals are sent to the specified bus.

Using libraries

This section explains basic operations for libraries. Libraries allow you to store and recall settings for the currently selected channel (EQ/dynamics) or rack (GEQ/effect).

The following libraries are provided.

- **Input EQ library**
- **Output EQ library**
- **Dynamics library**
- **GEQ library**
- **Effect library**

The method of operation is essentially the same for each library.

● Recalling settings from a library

1 Open a popup window that provides the tool buttons.

To access each popup window, proceed as follows.

[ATT/HPF/EQ popup window]

[DYNAMICS 1/2 popup window]

In the SELECTED CHANNEL VIEW screen or the OVERVIEW screen, press the appropriate field for EQ or Dynamics 1/2.



- ① **EQ graph field**
- ② **Dynamics 1/2 field**

3

Basic operation of the M7CL

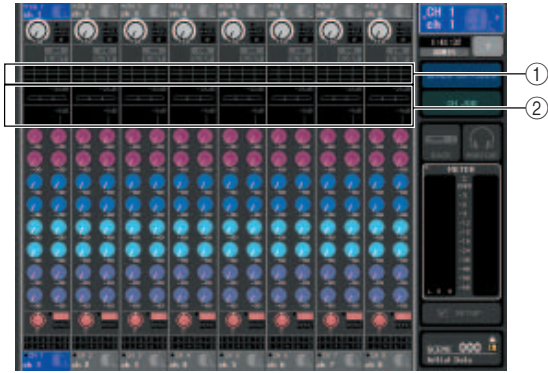

- ① EQ graph field
- ② Dynamics 1/2 field

[GEQ/EFFECT popup window]

In the VIRTUAL RACK window that appears when you press the RACK button in the function access area, press a rack in which a GEQ/effect is already mounted.

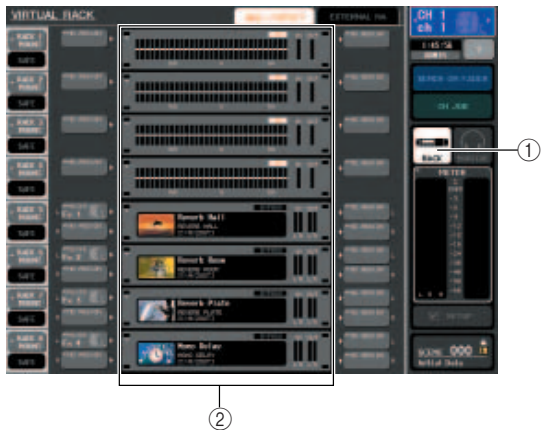

- ① RACK button
- ② Racks

2 Select the channel (EQ/dynamics) or rack (GEQ/effect) for which you want to recall settings.

The method of selecting a channel or rack will depend on the type of popup window that is displayed.

[ATT/HPF/EQ popup window (1 ch)]

[DYNAMICS 1/2 popup window (1 ch)]

Use the panel [SEL] keys or the channel select button in the function access area to select a channel.

Channel select button



[ATT/HPF/EQ popup window (8 ch/ALL)]

[DYNAMICS 1/2 popup window (8 ch/ALL)]

In addition to using the panel [SEL] keys or the channel select button in the function access area, you can also select a channel by pressing the channel number / channel name buttons in the popup window.

Channel number / Channel name buttons



If you use the channel number / channel name buttons in the 8 ch/ALL popup window, you can select multiple channels by selecting a region. In this case, the same library data will be recalled to all of the selected channels.

Selected region

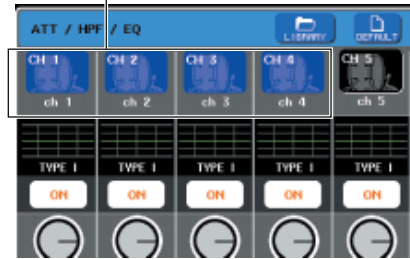

[GEQ/EFFECT popup window]

Use the rack select tabs at the bottom of the popup window to select a rack.



Rack select tabs

NOTE

- You can't select a rack select tab of a rack in which no GEQ or effect is mounted.

3 Press the LIBRARY tool button to open the corresponding library window.

Library windows contain the following items.

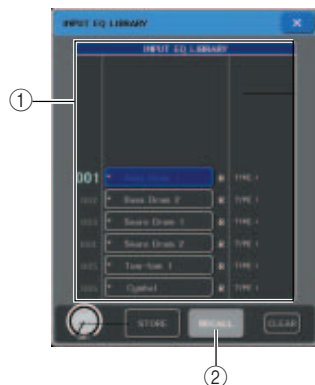

① List

This shows the data saved in the library. A highlighted line indicates that it is selected for operations. Read-only data is indicated by an R symbol.

HINT

- The right side of the list shows information (such as the dynamics type or effect type used) about the corresponding data. The dynamics library also displays symbols indicating whether the data can be recalled into Dynamic 1 and/or Dynamics 2.

② RECALL button

This recalls the data selected in the list into the currently selected channel (EQ/dynamics) or rack (GEQ/effect).

4 By turning any one of the multifunction encoders, move the highlighted line in the list to select the library item you want to recall.

Depending on the data you've selected for recall, it may not be possible to recall it into the currently selected channel or rack. Each library has the following restrictions.

● Dynamics library

The dynamics library contains three types of data; Dynamics 1 and Dynamics 2 for input channels, and Dynamics 1 for output channels. You can't recall the data if an inappropriate type of dynamics data is selected in the library.

● GEQ library

The GEQ library contains two types of data; 31 Band GEQ or Flex15GEQ. You can't recall the data if the type selected in the library is different than the type of the recall-destination GEQ.

● Effect library

Effect library items that use effect types "HQ.Pitch" and "Freeze" can be recalled only to rack 5 or 7. These cannot be recalled if any other rack is selected.

If you select a library number that cannot be recalled, it will not be possible to press the RECALL button.

5 Press the RECALL button.



- You can make settings so that a dialog box will ask you to confirm the Recall operation. For details on this setting, refer to p. 198.



6 The selected data will immediately be loaded into the channel (EQ/dynamics) or rack (GEQ/effect) you selected in step 2.

● **Storing settings in a library**

1 Open a popup window that provides the tool buttons.

2 Select the channel (EQ/dynamics) or rack (GEQ/effect) whose settings you want to store.



- You can select only one channel or rack as the source for storing. If multiple channels are selected in the dynamics/EQ popup window (8 ch or ALL), you won't be able to perform the Store operation.

3 In the upper part of the popup window, press the LIBRARY button to access the library.



1 STORE button

The settings of the currently selected channel (EQ/dynamics) or rack (GEQ/effect) will be stored to the position selected in the list.

4 Turn one of the multifunction encoders to select the store-destination library number.



- You can't store to a library number that contains read-only data (indicated by an R symbol).

5 When you've selected the store-destination, press the STORE button.

The LIBRARY STORE popup window will appear, allowing you to assign a title to the settings. For details on entering text, refer to "Entering names" (→ p. 30).



6 When you've assigned a title to the settings, press the STORE button in the LIBRARY store popup window.

A dialog box will ask you to confirm the Store operation.



7 To execute the Store operation, press the OK button.

The current settings will be stored to the library number you selected in step 4. If you decide to cancel the Store operation, press the CANCEL button instead of the OK button.



- Even after you've stored the settings, you can edit the title of the settings by pressing the data title in the list to access the LIBRARY TITLE EDIT popup window. However, you can't edit the title of a read-only library item (indicated by an R symbol).



- Be aware that if you store settings to a location that already contains data, the existing data will be overwritten. (Read-only data cannot be overwritten.)

● Erasing settings from a library

- 1 Open a popup window that provides the tool buttons.
- 2 In the upper part of the popup window, press the **LIBRARY** button to access the library.



① CLEAR button

This clears (erases) the settings that are selected in the list.

- 3 Turn one of the multifunction encoders to select the library item that you want to clear.



- You cannot clear read-only data (indicated by an R symbol).

- 4 Press the **CLEAR** button.

A dialog box will ask you to confirm the Clear operation.



- 5 To execute the Clear operation, press the **OK** button.

The data you selected in step 3 will be cleared. If you decide to cancel the Clear operation, press the **CANCEL** button instead of the **OK** button.

Initializing settings

Here's how you can return the EQ/dynamics settings of the currently selected channel or the effect settings of a rack to their default state. A GEQ can be initialized by the **FLAT** button in the screen.

- 1 Open a popup window that provides the tool buttons.
- 2 Select the channel (EQ/dynamics) or rack (effect) whose settings you want to initialize.
- 3 Press the **DEFAULT** button.

A dialog box will ask you to confirm the initialization operation.



- 4 To execute the initialization, press the **OK** button.

The EQ/dynamics of the channel or the effect settings of the rack you selected in step 2 will be initialized. If you decide to cancel the initialization, press the **CANCEL** button instead of the **OK** button.



- In the case of EQ/dynamics, you can use the channel number / channel name buttons in the 8 ch/ALL popup window to select a range of channels and initialize them in a single operation.

3

Basic operation of the M7CL

Copying/pasting settings

Here's how the EQ/dynamics settings of the currently selected channel or the GEQ/effect settings of a rack can be copied to a buffer memory and pasted to another channel or rack.

Copy/paste operations are restricted to the following combinations.

- Between input channel EQ settings
- Between output channel EQ settings
- Between dynamics processors for which the paste-destination has the same type (GATE, DUCKING, COMPRESSOR, EXPANDER, COMPANDER-H, COMPANDER-S, or DE-ESSER) as the copy-source
- Between effects mounted in a rack

HINT

- Only 31 Band GEQ settings that use less than fifteen bands can be copied to a Flex15GEQ.

- 1 Open a popup window that provides the tool buttons.
- 2 Select the channel (EQ/dynamics) or rack (GEQ/effect) whose settings you want to copy.
- 3 Press the COPY button.

The current settings will be saved in the buffer memory.

NOTE

- Be aware that if you copy other settings before you paste, the buffer memory will be overwritten.
- You can select only one channel or rack as the copy-source. If multiple channels are selected in the 8 ch/ALL popup window, you won't be able to press the COPY button.

- 4 Select the paste-destination channel or rack.

HINT

- If you're pasting EQ/dynamics settings, you can use the 8 ch/ALL popup window to select multiple channels as the paste-destination. In this case, the same content will be pasted to all selected channels.

- 5 Press the PASTE button.

The settings of the channel (EQ/dynamics) or the rack (GEQ/effect) you selected in step 2 will be pasted.

NOTE

- Be aware that when you paste, the settings will overwrite the paste-destination.
- If nothing has been stored in the buffer memory, the PASTE button cannot be pressed.
- Of the two types of GEQ, using the tool buttons in a rack where a Flex15GEQ is selected will cause the settings to be copied/pasted individually.
- Effect settings with an effect type of "H.Q.Pitch" or "Freeze" cannot be pasted to rack 6 or 8.

Comparing two settings

You can use the COMPARE button to exchange the settings held in the buffer memory with the settings of the currently selected channel (EQ/dynamics) or rack (GEQ/effect). This is convenient when you want to temporarily keep the settings at a certain point, and compare them later with the subsequently edited settings.

- 1 Open a popup window that provides the tool buttons.
- 2 Select a channel (EQ/dynamics) or rack (GEQ/effect).
- 3 Press the COPY button to place the current settings in the buffer memory.

This will be the first set of settings.

NOTE

- Be aware that if you copy other settings before you compare, the buffer memory will be overwritten.

- 4 Edit the settings of the currently selected channel (EQ/dynamics) or rack (GEQ/effect).

This will be the second set of settings.

HINT

- After you've stored the first set of settings in the buffer memory, you can initialize the channel or rack and edit the second set of settings from an initialized state if desired.

5 To compare the first set of settings with the current settings (the second set), press the COMPARE button.

You will return to the first set of settings. At this time, the second set of settings will be held in the buffer memory.

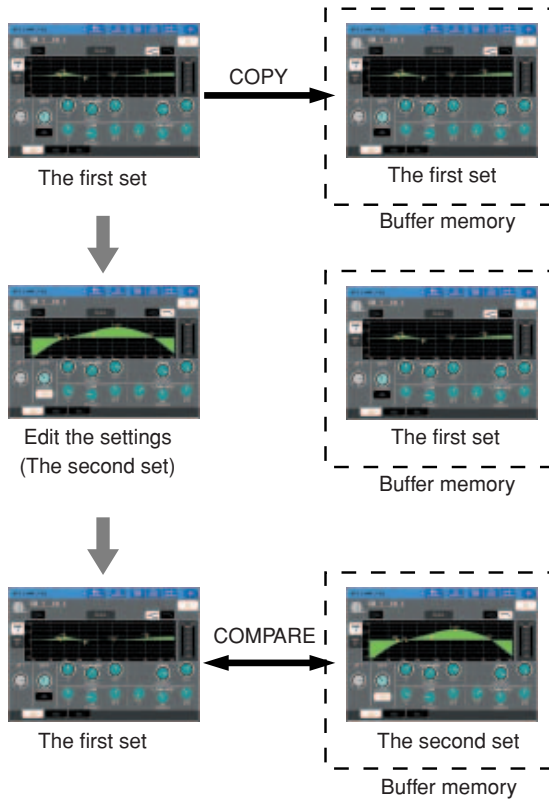

6 You can press the COMPARE button repeatedly to compare the first and second sets of settings.

Each time you press the COMPARE button, the current settings will be exchanged with the settings held in the buffer memory.

Unlike the Paste operation, the Compare operation always lets you return to the previous settings as long as the buffer memory has not been overwritten.

HINT

- The settings in the buffer memory can also be used for the Paste operation.

NOTE

- Of the two types of GEQ, using the tool buttons in a rack where a Flex15GEQ is selected will cause the settings to be exchanged individually with the buffer memory.



◆ Chapter 4 ◆

Connections and setup

This chapter explains how to make audio input/output connections, and how to perform the setup required when starting the M7CL for the first time.

4

Connections and setup

Connections

■ Analog input connections

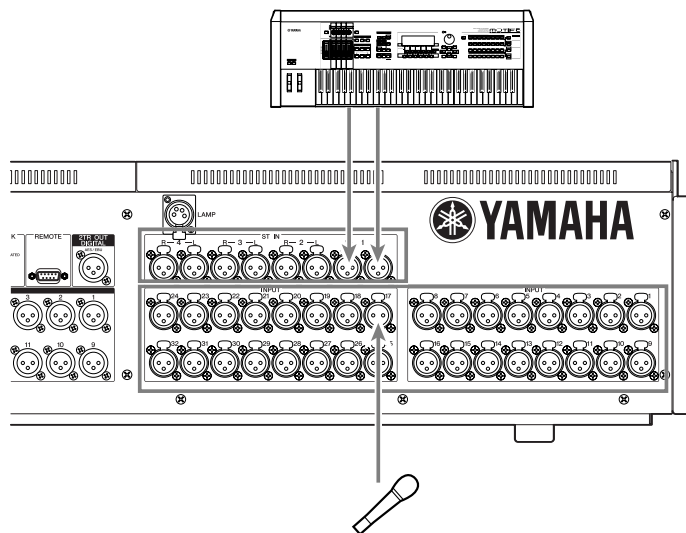

INPUT jacks 1–32 {1–48} are used mainly to connect microphones or monaural line-level devices. ST IN jacks 1–4 (L/R) are used mainly to connect stereo line-level devices.

NOTE

- In the default state, the ST IN jacks are not patched. (Racks 5–8 are assigned to the ST IN channels.) In order to use the signals connected here as inputs, you will need to make patch settings.

■ Analog output connections

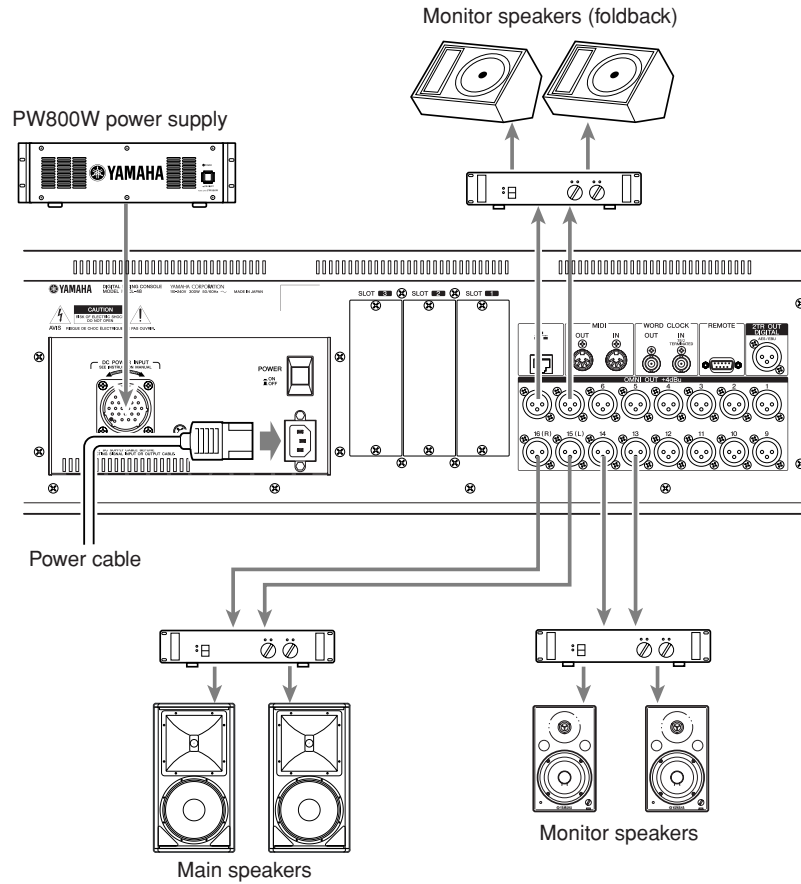

To the OMNI OUT jacks 1–16, you can patch the output signals from output channels (MIX, MATRIX, STEREO (L/R), MONO (C)), monitor signals (MONITOR OUT L/R/C channel), and the direct out signals of INPUT channels 1–32 {1–48}. When the M7CL is in the default state, the signals of the following channels are patched to each output port. (You are free to change this patching as desired.)

OMNI OUT jacks 1–12	MIX channels 1–12
OMNI OUT jacks 13/14	MATRIX channels 1/2
OMNI OUT jacks 15/16	STEREO channel (L/R)

Below the M7CL's front pad there is a PHONES OUT jack for monitoring, and this jack always lets you monitor the signal that is selected as the monitoring source (→ p. 141). By assigning the MONITOR OUT L/R/C channels to the desired output jacks, you can monitor this same signal through external speakers (→ p. 142).

HINT

- If you connect the power cable to the AC IN jack and also connect the separately sold PW800W power supply, power will continue to be supplied from the PW800W even if the internal power supply shuts down due to a problem.