

**Owner's Manual / Fitting Instructions**  
Kit Nos. 8514 & 8515

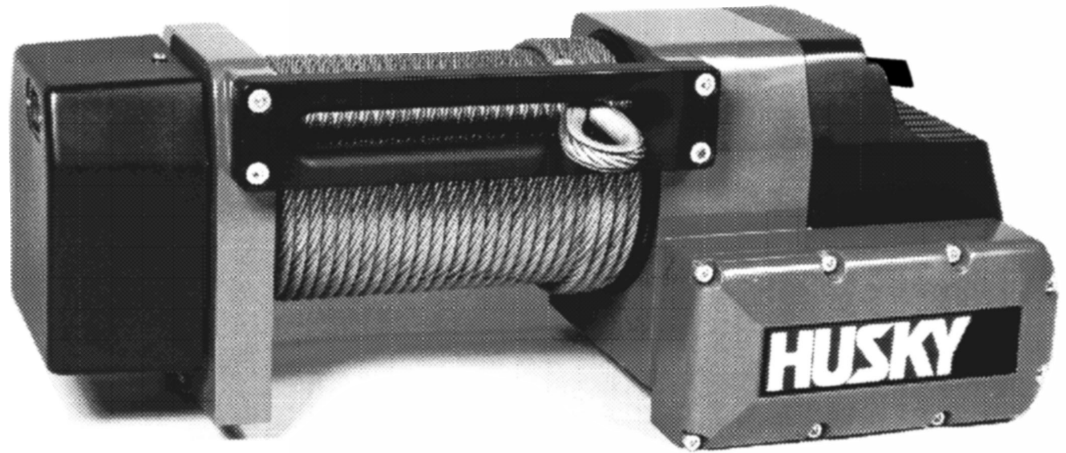

ELECTRICALLY  
POWERED  
HUSKY WINCH

**SUPERWINCH<sup>®</sup>**

# Owner's Manual / Fitting Instructions

Kit Nos.  
8514 & 8515



These instructions cover kits from  
16/07/1997

- 01 INTRODUCTION
- 02 GENERAL SPECIFICATION DATA  
INTERMITTENT DUTY
- INSTALLATION
- 03 WINCH
- 04 ELECTRICAL
- 05 WIRE ROPE
- COMMISSIONING AND USE
- 06 TIPS FOR EXTENDING THE LIFE OF YOUR WINCH
- 07 FREESPOOL USE  
REMOTE CONTROL OPERATION
- MAINTENANCE
- 08 RUNNING IN, MAINTENANCE AND REPAIRS  
LUBRICATION
- 09 TROUBLESHOOTING
- MISCELLANEOUS
- 10 ACCESSORIES

For all your requirements please contact your Superwinch agent:

**SUPERWINCH®**

---

## INTRODUCTION

---

Please read and understand this owner's manual before installing your Husky winch. Your Husky winch is a very powerful machine. If used unsafely or improperly, there is a possibility that property damage or personal injury can result. We have included several unique features in the Husky winch to minimize this possibility; however, your safety ultimately depends on your caution when using the product.

Correct installation of your Husky winch is a requirement for proper operation.

Please Note: The Superwinch Husky winch is designed for total reliability during vehicle recovery operations. This winch is not designed to be used in hoisting applications and Superwinch does not warrant it suitable for such use.

Superwinch reserve the right to alter model specifications without prior notice.

### PLEASE RETAIN THIS HANDBOOK WITH THE WINCH.

Pay particular attention to the caution noted preceded with the symbols shown here. The notes contain advice for your protection.

---

## WARNINGS, CAUTIONS AND NOTES

---

These are given through these instructions in the following form :



**WARNING :** Procedures which must be followed precisely in order to avoid the possibility of personal injury.



**CAUTION :** This calls attention to procedures which must be followed to avoid damage to components.



**NOTE :** This calls attention to methods which make a job easier or gives helpful information.

---

## USAGE OF WINCH

---

This winch is designed for use in applications such as:

\* Pulling \* Hauling \* Lifting (Vehicle Recovery ONLY) \* and other associated uses.

SUPERWINCH winches are not to be used to lift, support or otherwise transport personnel. Any such use shall be considered to invalidate the warranty and Superwinch shall not be responsible for any claims arising from such use.

---

## POISONOUS SUBSTANCES

---

Many liquids and other substances used should under no circumstances be consumed, and should be kept away from open wounds. These substances include (among others) hydraulic oil.

---

## SYNTHETIC RUBBER

---

Many 'O' ring seals, flexible pipes and similar items, when subjected to fire or heat can become highly corrosive. Handle with seamless industrial gloves only. Should skin contact occur, remove contaminated clothing immediately and obtain medical assistance without delay. Meanwhile, wash the affected area with copious amounts of cold water or limewater for 15 to 60 minutes.

---

## RECYCLING AND THE ENVIRONMENT

---

It is illegal to dispose of used oil in the ground, down sewers or drains or into waterways.

Dispose of used oil through authorised waste disposal contractors. If in doubt contact your local Authority for advice on disposal facilities.

---

## WINCHING TECHNIQUES

---

Before using your winch it is very important that you read the booklet sent to you with your winch entitled the 'Handbook of Winching Techniques for Vehicle Recovery'. Please read and understand this handbook before using your Superwinch and it's accessories. It has been supplied with your winch to encourage safe operation - if used unsafely or improperly, there is a possibility that property damage or personal injury can result, since your safety ultimately depends on your caution when using these products.

**WINCH**

Type .....	Husky
Gear Reduction .....	Wormwheel
Gear Ratio .....	294:1 (12v) & 229:1 (24v)
Drum .....	Fabricated steel running in copolymer maintenance free bearings with spring loaded brakes to prevent overrun when pulling out the rope.
Braking .....	The irreversible action of the worm and wormgear provides for substantial braking action.
Freespool .....	Operated by an easy action lever which disengages the gear box to allow the wire rope to be pulled out without using electric power. A spring loaded drag mechanism reduces backlash and snarling when pulling out the wire rope.
Control Solenoids (relays) .....	Boxed pair of solenoids can be mounted direct on winch or remotely as required.
Remote Switch .....	3.5m hand held pendant switch assembly.

Model Designation.....	<b>Husky</b>	<b>Husky</b>
Part No .....	8514	8515
Electric Motor .....	12v 1.4 Kw (1.9 hp)	24v 1.6 Kw (2.1 hp)
Rated Line Pull Bottom Layer .....	37.8 kN (8500 lbs)	37.8 kN (8500 lbs)
Line Speed 1st Layer (No Load) .....	6.9 m/min (22 ft/min)	6.9 m/min (22 ft/min)
Rope Diameter (Recommended) ....	9 mm	9 mm
Rope Length .....	30 m (100 ft)	30 m (100 ft)
Drum Diameter .....	76.2 mm (3")	76.2 mm (3")
Current Draw at Rated Line Pull ....	340 A	180 A
Weight .....	38 kg (84 lbs)	38 kg (84 lbs)

**8514**

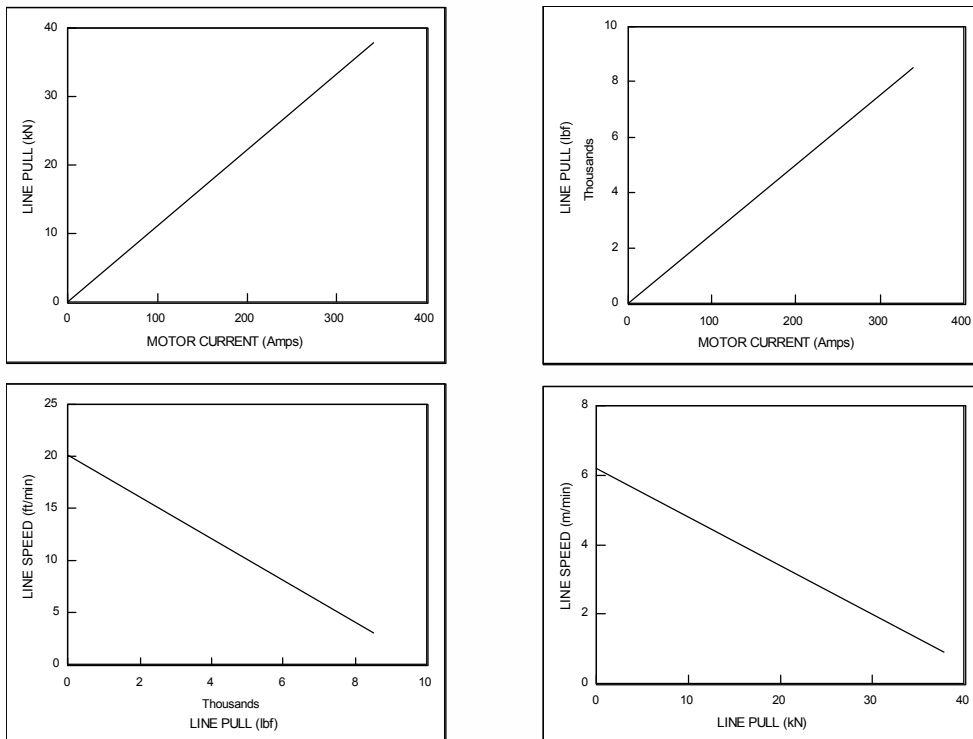

Fig. 1

8515

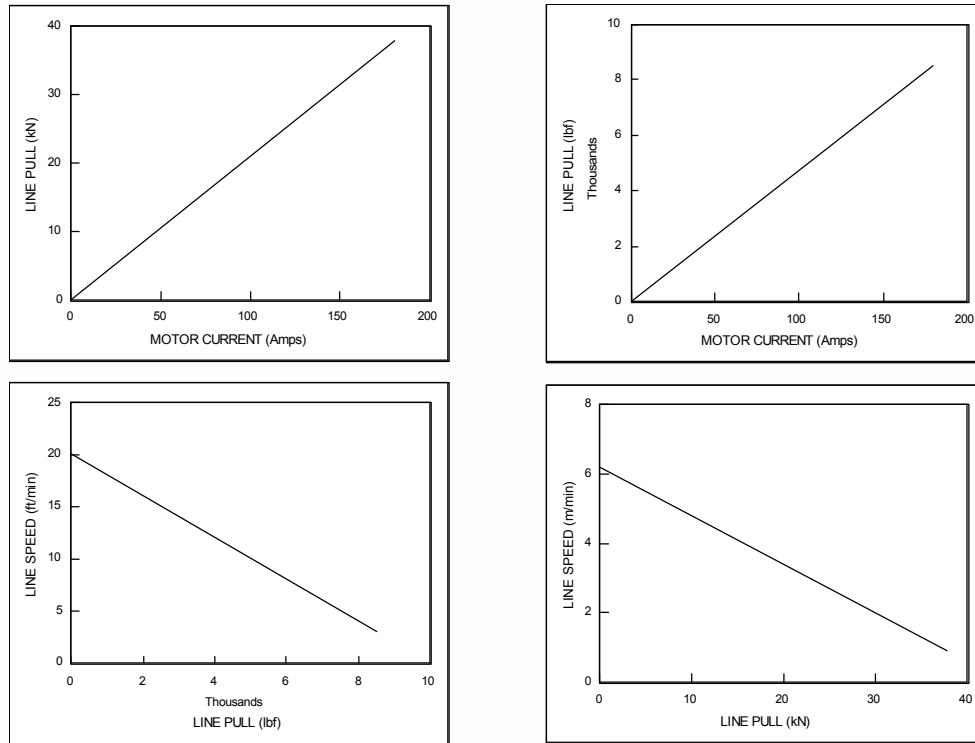

Fig. 2

### INTERMITTENT DUTY

All electric winches of this size are rated for intermittent use because of the electric motor efficiency and the electric power available from the vehicle battery and alternator. This means that the winch must only be used for short periods of time then allowed to cool down.

If the motor becomes uncomfortably hot to touch, stop winching and allow the motor to cool.

If the winch motor stalls do not continue to apply power to the winch.

The performance rating of all electric winches is based on the first layer of rope on the drum. The winch pulling capacity decreases as each successive layer of rope wraps onto the drum.

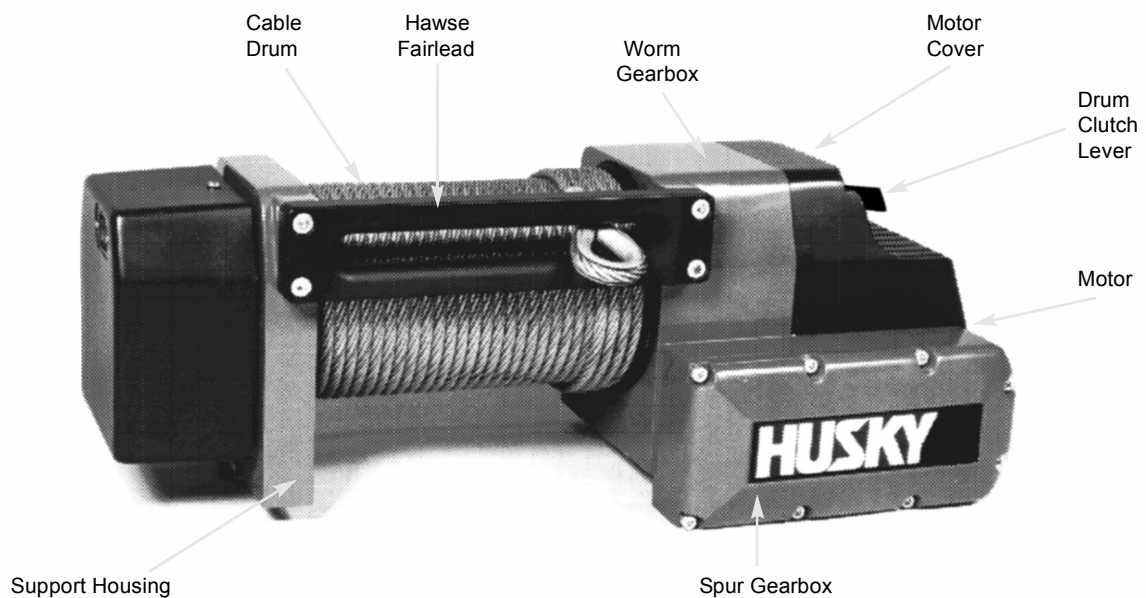

Fig. 3

**WINCH INSTALLATION**

The kit must be used in conjunction with the included wiring kit. Before commencing installation identify the contents of the following:

**Contents, Cardboard Container**

Item	Qty	PART No.	Description
1	1		Husky Winch Assembly
2	1	9134 / 207	Power Cable 0.7m Red
3	1	9134 / 307	Power Cable 0.7m Blue
4	1	9134 / 407	Power Cable 0.7m Yellow
5	1	8903 (12v)	Control Box
	1	8904 (24v)	Control Box
6	1		Plastic Bag
7	1	8857	Remote Control, 6m

**Contents, Bag 1**

Item	Qty	PART No.	Description
8	2		Plastic Bags
9	1	8057	Handsaver Bar
10	1	5-001-078	Owners Manual
11	1	5-010-080	Winching Techniques
12	1		Certificate of Conformity

**Contents, Bag 2**

Item	Qty	PART No.	Description
13	4	7804	Spacer
14	4	4-33-1005032	Bolt, M10 x 50mm
15	4	4-36-0803522	Cap Head Set Screw M8 x 35mm
16	1	351	Bolt, 5/16" UNF x 3/4"
17	4	4-50-1023	Washer, Plain, M10
18	4	4-50-0823	Washer, Plain, M8
19	5	4-51-0823	Washer, Spring, M8
20	4	4-51-1023	Washer, Spring, M10

**Contents, Bag 3**

Item	Qty	PART No.	Description
21	1	4-122-1083	Hexagon Socket Set Wrench 1/4"
22	1	4-122-2053	Hexagon Socket Set Wrench 4mm
23	1	4-122-2073	Hexagon Socket Set Wrench 6mm

# 03

## WINCH INSTALLATION

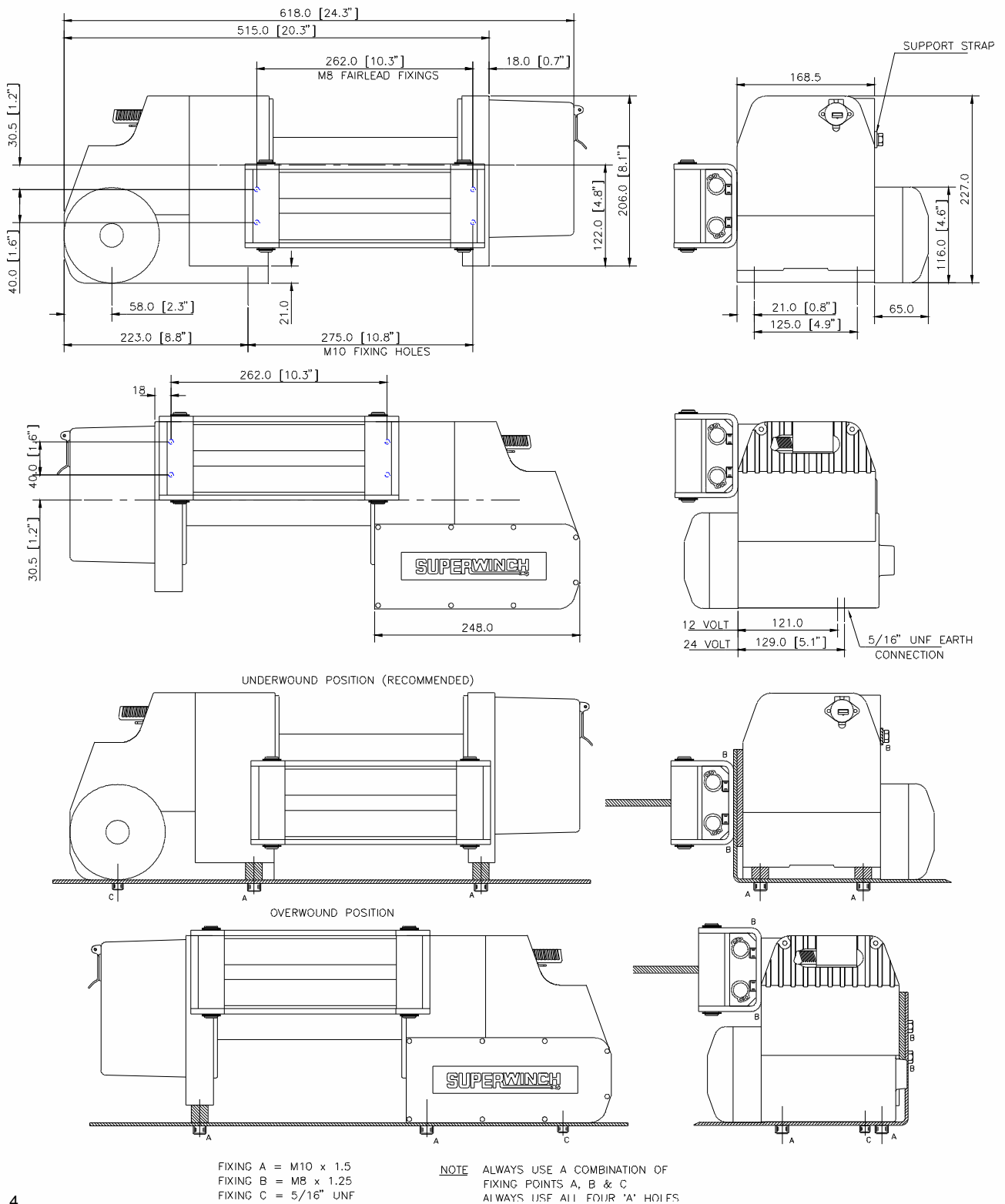

Fig. 4

## WINCH INSTALLATION

1. All dimensions are in mm.
2. Winch mounting can be via a winch mount plate (See SuperwinchAccessories).
3. The winch (together with it's mounting plate if fitted) must be securely bolted onto a mounting surface that is flat within 0.5mm and sufficiently stiff to prevent flexing.
4. All four winch mounting holes marked 'A' must be used.
5. Although the winch may be mounted in either 'overwound' or 'underwound' positions, 'underwound' is recommended.
6. Mounting bolts must be 8.8 grade high tensile steel.

## ELECTRICAL INSTALLATION



**Precautions:** Leave all cable connections to the battery terminals unconnected until all wiring has been installed and checked thoroughly for correct connections, as damage to the vehicle wiring circuit could be caused by wrong connection once the battery is connected. All wiring should be bound and securely fastened to adjacent structure using the cable ties supplied where necessary.

Because of the high current draw inherent in all electric winches it is recommended that the engine of your vehicle is kept running during the winching operation to ensure that the battery is not drained for vehicle restarting.

Be sure that the battery is always fully charged and maintained.

The performance of an electric winch is directly dependant on the quality and capacity of the battery and alternator. If the winch is in heavy use, an auxiliary battery and heavy duty alternator with a battery isolator are recommended.



It is **essential** to use the control solenoids supplied with your winch so that burn out of the electric system does not occur.



**Warning:** Do not, under any circumstances, wire the winch direct from the vehicle battery. Do not connect either winch or solenoids to 240 volt a.c. house current as solenoid burn out or fatal shock may occur.



**Note:** For safety reasons, we recommend the installation of Isolator switch PartNo. 8370, which can be used to cut power to the winch. The switch should be wired in line with the power lead from the battery positive terminal (see wiring diagrams). It should be mounted in a position where power can be switched off in an emergency.

The winch operates on standard automotive 12 or 24 volt direct current.

Step (1) Disconnect the battery 'negative' terminal connection.

Step (2) Remove the solenoid cover.



**Caution:** When attaching wires to the motor terminals and solenoids, hold the inner nut when tightening the outer nut. Do not allow the motor or solenoid terminals to rotate causing internal wire breakage. See pages 24 and 25 for relevant diagrams.

Step (3) Remove motor cover. Check motor terminals against wiring diagram for identification.

Step (4) Attach lead wires as shown in wiring diagram (Fig. 5). Please note that lead wires are not supplied for connection to the battery +ve and -ve. This is because these leads can be of very different lengths dependant on the various vehicle / mount configurations. The wire used to power the winch offers resistance to the flow of electric current. The longer the wire the more the resistance. When more resistance to current flow occurs, less current is available at the motor causing it to run slower and have less power.

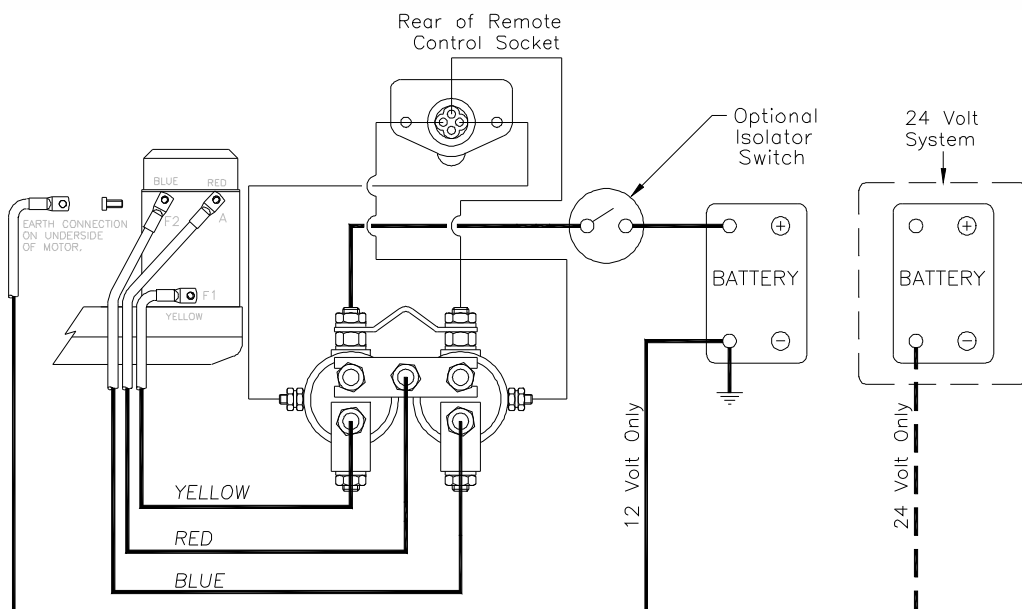

All Power Cables 35mm<sup>2</sup>  
Remote Socket Cables 1.5mm<sup>2</sup>

Fig. 5



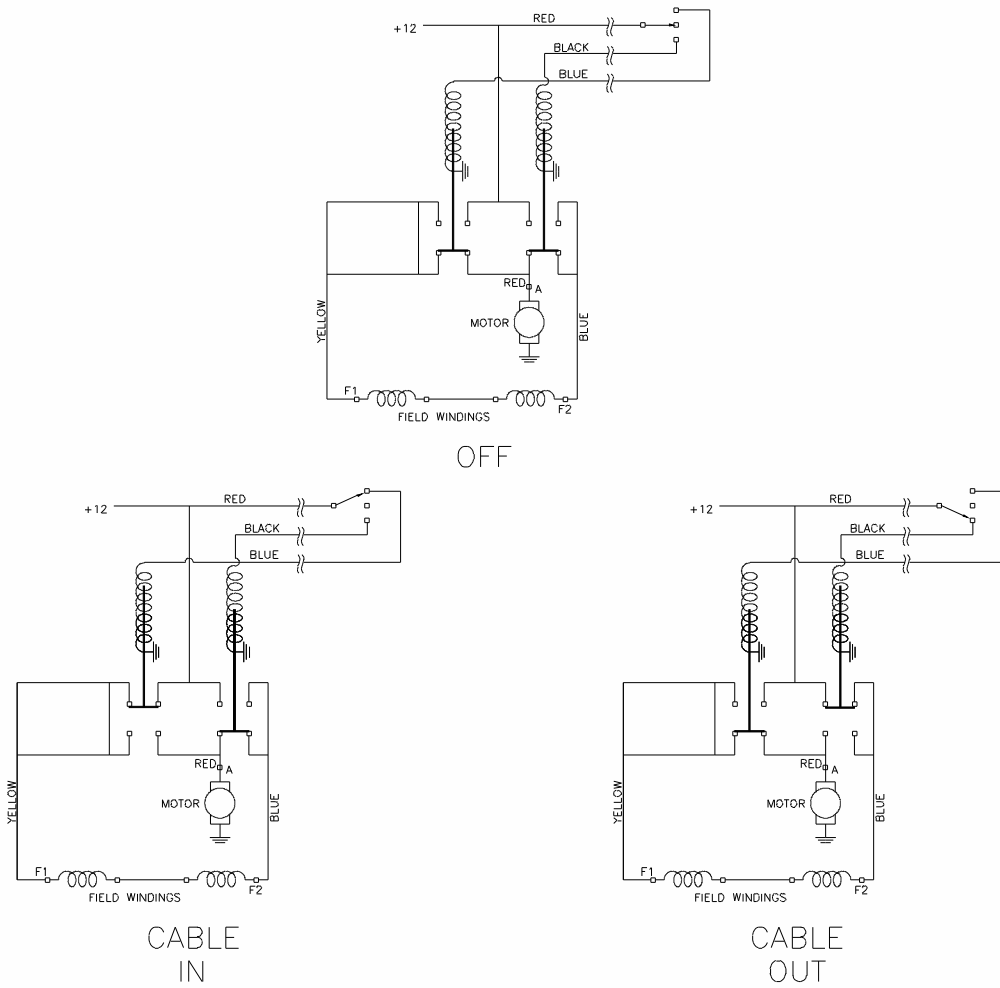

Fig. 6

To determine the size wire required to operate your winch you must first calculate the resistance from the following formula:

$$\Omega = \frac{2000}{D \times I} = \text{ohms} / 1,000 \text{ ft}$$

where:

- $\Omega$  = Total resistance in ohms / 1,000 ft
- D = Total distance the electric current must travel, i.e. distance from battery -ve terminal to motor added to distance from battery +ve to solenoids.
- I = 340 (Husky 5254) or 180 (Husky 5255)

Now select the wire gauge from the table opposite.

Note that the connectors must be to suit 8mm studs and the selected wire gauge.

Wire Gauge (AWG)	Resistance ( $\Omega$ )
4/0	0.04901
3/0	0.06180
2/0	0.07793
1/0	0.09827
1	0.1239
2	0.1563
4	0.2485
6	0.3951
8	0.6282
10	0.9989

## WIRE ROPE SPECIFICATION

The rope must be of good quality, have a steel core and meet the following specifications:

Model Designation .....	Husky
Part No. ....	8514 & 8515
Drum Diameter .....	76.2 mm
Calculated Min. Breaking Load .....	51.0 kN (11464 lbf)
Tensile Grade .....	1770 N/mm <sup>2</sup>
Rope Diameter .....	9.0 mm
Max. Rope Length .....	30 m

## WIRE ROPE INSTALLATION

When the winch is supplied from the factory without wire rope fitted, you should install the rope in the following sequence. The installation of a rope is a simple procedure. It is a good idea to have someone to help you with this. First make sure the remote control is unplugged to prevent unauthorised use when your working around the rope storage drum.

1. Unwind the cable by rolling it along the ground with the tapered end nearest to the winch. **Never** wind the cable straight onto the drum from a coil (Fig. 8).
2. Move the clutch handle to the 'disengaged' position as shown in Fig. 7.
3. Insert the tapered end of the rope through the fairlead and onto the drum. In the overwound position, pass the rope straight into the rope fixing hole. In the underwound position, pass the rope under the rope drum and thread the rope into the fixing hole from drum. Fix the end of the rope with the setscrew.
4. Move the clutch handle to the 'engage' position (Fig. 7). Connect the remote control. If the lever does not slide easily into engagement, it may be necessary to momentarily operate the control switch then release to the off position.
5. Carefully run the winch in the 'winch in' direction. Keeping tension on the cable spool 5 or 6 wraps of cable neatly onto the drum.
6. Apply moderate tension (approx. 1500 kg) to the rope. This may be achieved by anchoring the rope hook (with a sling) to a tree and winching the vehicle towards the tree with brakes applied lightly. Take care to ensure the layers are neatly wrapped. This will minimise damage to the lower layers of rope when a load is applied. Use the handsaver bar to guide the rope the last few feet onto the drum.

**Note;** Where a wire rope is not supplied, or when replacing a wire rope, always use a Superwinch recommended wire rope.

## PULLING THE WIRE ROPE OUT

Move the clutch handle to the 'disengage' position. Pull out the rope and secure to anchor or load, check that there are at least 5 turns left on the drum.

Re-engage the drum by moving the clutch handle to the 'engage' position (Fig. 7). If the handle does not slide easily into engagement, it may be necessary to momentarily operate the control switch then release to the off position.

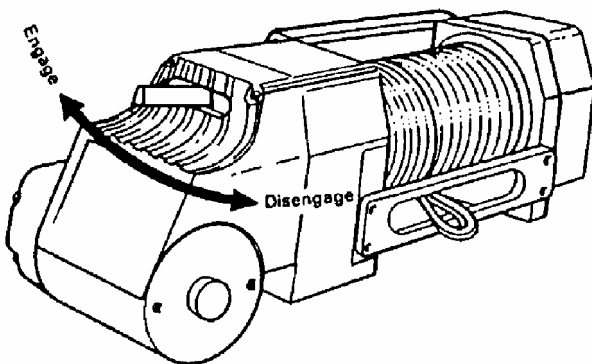

Fig. 7



Fig. 8

1. **Keep a tightly wound wire rope drum.** Do not allow the wire rope to become loosely wound. A loosely-wound spool allows a wire rope under load to work its way down into the layers of wire rope on the drum. When this happens, the wire rope may become wedged within the body of the windings damaging the wire rope. To prevent this problem, keep the wire rope tightly and evenly wound on the drum at all times. A good practice is to rewind the wire rope under a tension of approx. 500 kg after each use. For example, this can be achieved by attaching the hook to a car and recovering with the winch using the car's brakes to control the load.
2. **Do not allow motor to overheat.** Remember, the winch is for intermittent use only. During long or heavy pulls the motor will get hot. The internal parts will be hotter than the case. To check the motor temperature, stop winching and carefully touch the motor case, if the motor is uncomfortably warm, allow the motor to cool before continuing - keep the engine running to recharge the battery during this break.
3. **Use of a pulley block and shackle for heavy loads.** To maximise winch and wire rope life, use a pulley block and shackle to double line heavier loads.
4. The pull required to start a load moving is often much greater than the pull required to keep it moving. **Avoid frequent stopping and starting** during a pull.
5. **Prevent kinks before they occur.**

(Fig. 9a) This is the start of a kink. At this time, the wire rope should be straightened.

(Fig. 9b) The wire rope was pulled and the loop has tightened to a kink. The wire rope is now permanently damaged and must be replaced.

(Fig. 9c) The result of kinking is that each strand pulls a different amount causing the strands under greatest tension to break and reduce load capacity of the wire rope. The wire rope must be replaced.

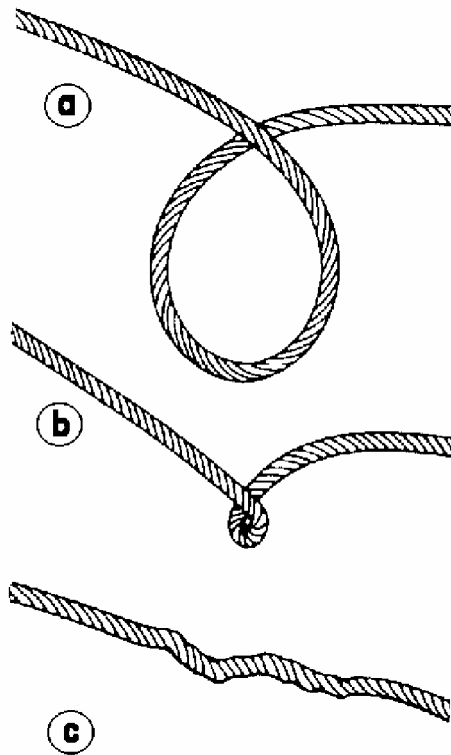

Fig. 9

**FREESPOOL OPERATION**

When wire rope is removed from the drum, as in bringing the hook to the load, the freespool features of the winch should be used.

To Engage: Turn the freespool handle to the 'engage' position. Pull the rope out (wearing a pair of gloves) until the freespool pin engages (the handle drops).

To Disengage: Lift and turn the freespool handle to the 'disengage' position (the handle stays up).

**REMOTE CONTROL OPERATION**

The winch power is supplied via a hand held remote control handset, supplied with a 3.5 meter cable, which enables winch-in and winch-out. To operate, connect the remote control into the socket (marked with a caravan logo) by lifting the flap and inserting the plug. The plug is keyed to ensure correct connection. To winch in, move the switch downwards. To winch out, move the switch upwards. To remove the plug from the socket, lift the flap slightly and remove the plug.

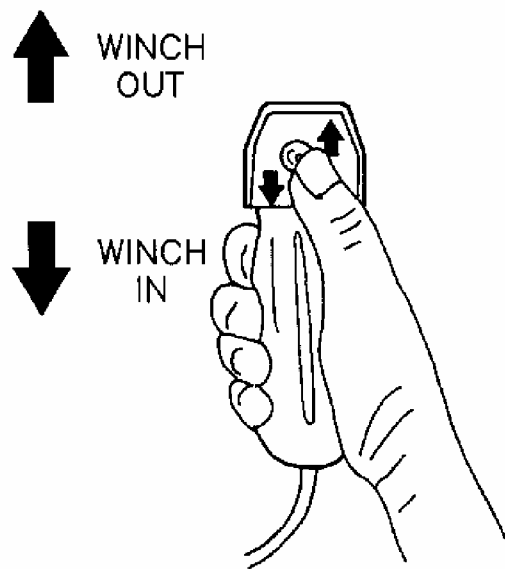

Fig. 10

The gearbox drive in the Husky winch can be disengaged to enable free-spooling of the rope storage drum so that the rope may be pulled out. **Do not** operate the remote control in this case.

Winch Out Mode: Instantaneous stopping of the load during "Winch Out" mode may be achieved by momentarily operating the control switch in the "Winch In" mode then releasing to the "Off" position.

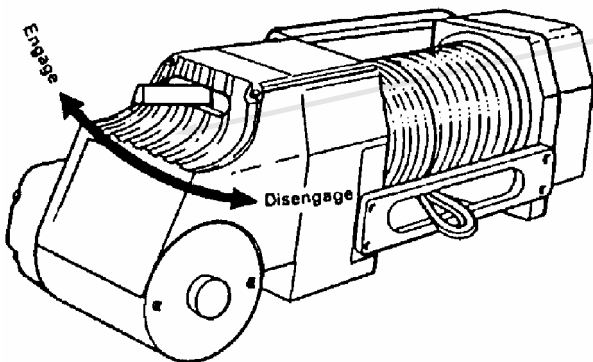

Fig. 11



Fig. 12

## RUNNING-IN

### IMPORTANT

Ensure your winch has been filled with oil before proceeding.

Fitted to your winch is a precision worm and wheel set.

Extra time spent running-in is well repaid by a more efficient and reliable winch.

Your winch must **never** be used to pull heavy loads until it has been run-in as below.

1. Run the winch with no load or very light load for 1 - 2 hours.
2. **Gradually** increase the load up to maximum over a period of 2 or 4 hours (the longer the better). Drain worm box and refill with fresh BP Energol Hypo 85W/140 Oil.

## MAINTENANCE AND REPAIRS

Periodically check tightness of mounting bolts and electrical connections. Remove any dirt or corrosion that may have accumulated on the electrical connections.

Repair should be carried out by Authorized Superwinch Repair Centres only. Do not attempt disassembly of the gearbox. Disassembly will void warranty.

**After the first 10 hours of operation:** Change worm gearbox oil (See Fig. 13 for location of drainhole and level plug). Check tightness of mounting bolts and electrical connections.

**Monthly:** Check tightness of all electrical connections and remove any dirt or corrosion that may have accumulated. Check oil level in worm gearbox. Oil level should be maintained to the lower edge of the level plug hole with the winch in the upright position as shown in Fig. 13.

**After 50 hours of winching or annually:** Change worm gearbox oil. Check tightness of mounting bolts and electrical connections.

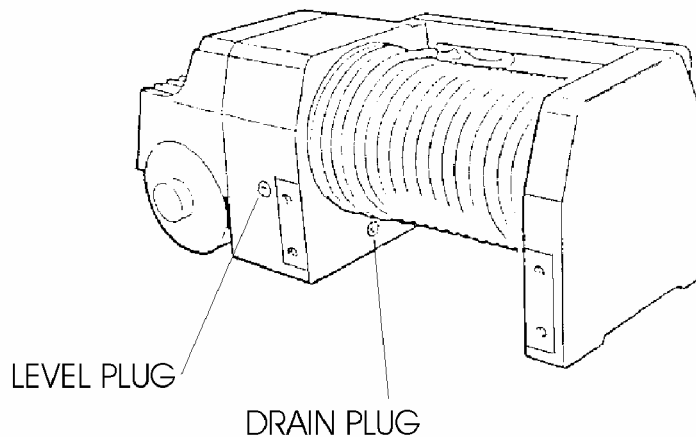

## LUBRICATION

The spur and worm gearboxes are self contained and individually lubricated. The spur gearbox is factory filled for life with BPEnergrease FGL which is suitable for most climates. In extreme climates, (below 13°C or above 43°C) contact Superwinch for advice.

CLMIMATE	TEMPERATURE	WORM GEARBOX
Arctic	-13°C to 15°C	SAE 90 Oil
Temperate	-16°C to 29°C	SAE 85 / 140 Oil
Tropical	19°C to 43°C	SAE 140 Oil

**Note:** EP (Extreme Pressure) additives can damage copper based alloys like phosphor bronze used for the worm gear and we do not recommend their use in the worm gearbox. If any doubt exists, consult your lubricant supplier's technical department.

The drum bearings and splined drum clutch are lubricated with molydisulphide loaded bearing grease.

Condition	Possible Cause	Correction
Motor will not operate or motor runs in one direction only	Damaged or stuck solenoid; most likely caused by not holding the inner nut to keep the stud from turning when attaching wire to solenoid	Caution: disengage clutch before performing this test to prevent powering the wire rope drum. If a solenoid sticks once, it is likely to stick again and must be replaced immediately. Tap solenoid to free stuck contacts. Check by applying voltage to the small solenoid terminal. Be sure solenoid is grounded back to source. A solenoid that is not stuck will make an audible click when first engaged.
	Switch inoperative	Replace switch
	Broken wire or bad connection	Check for poor connections
	Damaged motor	Return to Authorised Superwinch Repair Centre.
Winch will not shut off	Solenoids not grounded	Check the ground path between battery negative and solenoid base.
	Solenoid stuck "on"	If solenoid sticks on, reverse direction and hold trigger switch on until the power lead can be disconnected, A safety disconnect switch is available as an accessory.
Motor runs extremely hot	Long period of operation	Allow to cool.
	Damaged motor	Return to Authorised Superwinch Repair Centre.
	Damaged brake	Return to Authorised Superwinch Repair Centre.
Motor runs but with insufficient power or line speed	Weak battery	Recharge or replace battery. Check charging system.
	Battery to winch wire too long	Use larger wire.
	Poor battery condition	Check battery terminals for corrosion. Clean, retighten and coat with thin film of grease to prevent further corrosion.
	Poor ground	Check and clean connections.
	Damaged brake	Return to Authorised Superwinch Repair Centre.
Motor runs but drum does not turn	Clutch not engaged	Engage clutch.
Winch runs backwards	Motor wires reversed	Recheck wiring.
	Solenoids wired incorrectly	Recheck wiring.
Will not hold load	Excessive load	Reduce load or double line.
	Worn or damaged brake	Return to Authorised Superwinch Repair Centre.

### ACCESSORIES

Accessories mentioned in this manual and recommended for use with your winch include:

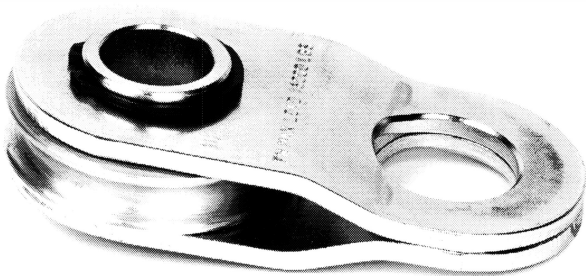

**Pulley Block with 20,000 lbs capacity**  
Part No. 7750

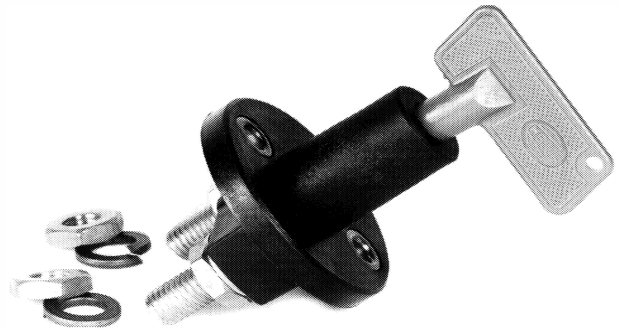

**Isolator Switch**  
Part No. 8370

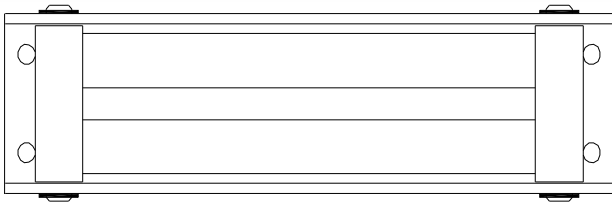

**Roller Fairlead**  
Part No. 7730

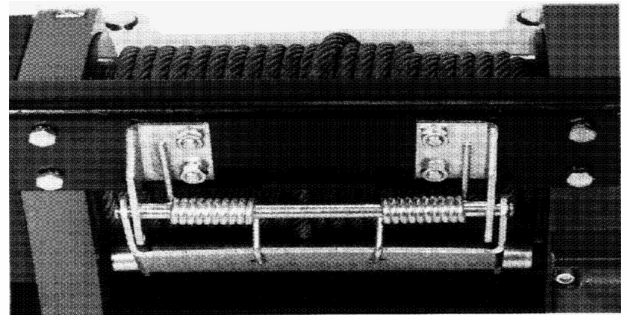

**Cable Tensioner**  
Part No. 5605

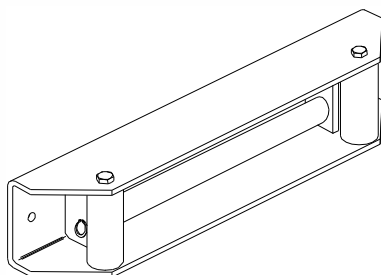

**Roller Fairlead (Heavy Duty)**  
Part No. 8584

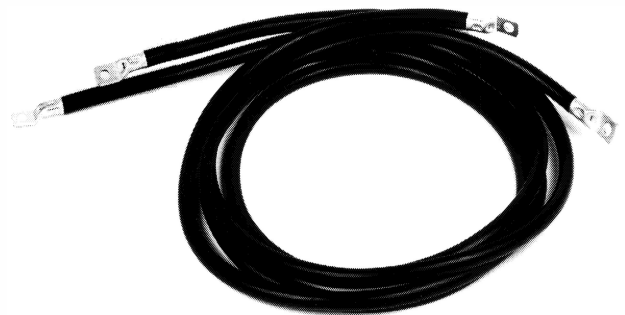

**Battery Cables (pair) 2m length**  
Part No. 7912