

*The*  
**WONDER FENCE**  
 All-Purpose Router/Shaper Split Fence ~ *by INCRA*

**From the makers of  
 INCRA JIG!**

- Split fence design
- Micro adjustable
- Universal dust collection port
- Adjustable fence gap
- Compatible with all INCRA joint-making accessories

**OWNER'S MANUAL**

*Please read this owner's manual before use and keep it at hand for reference.*

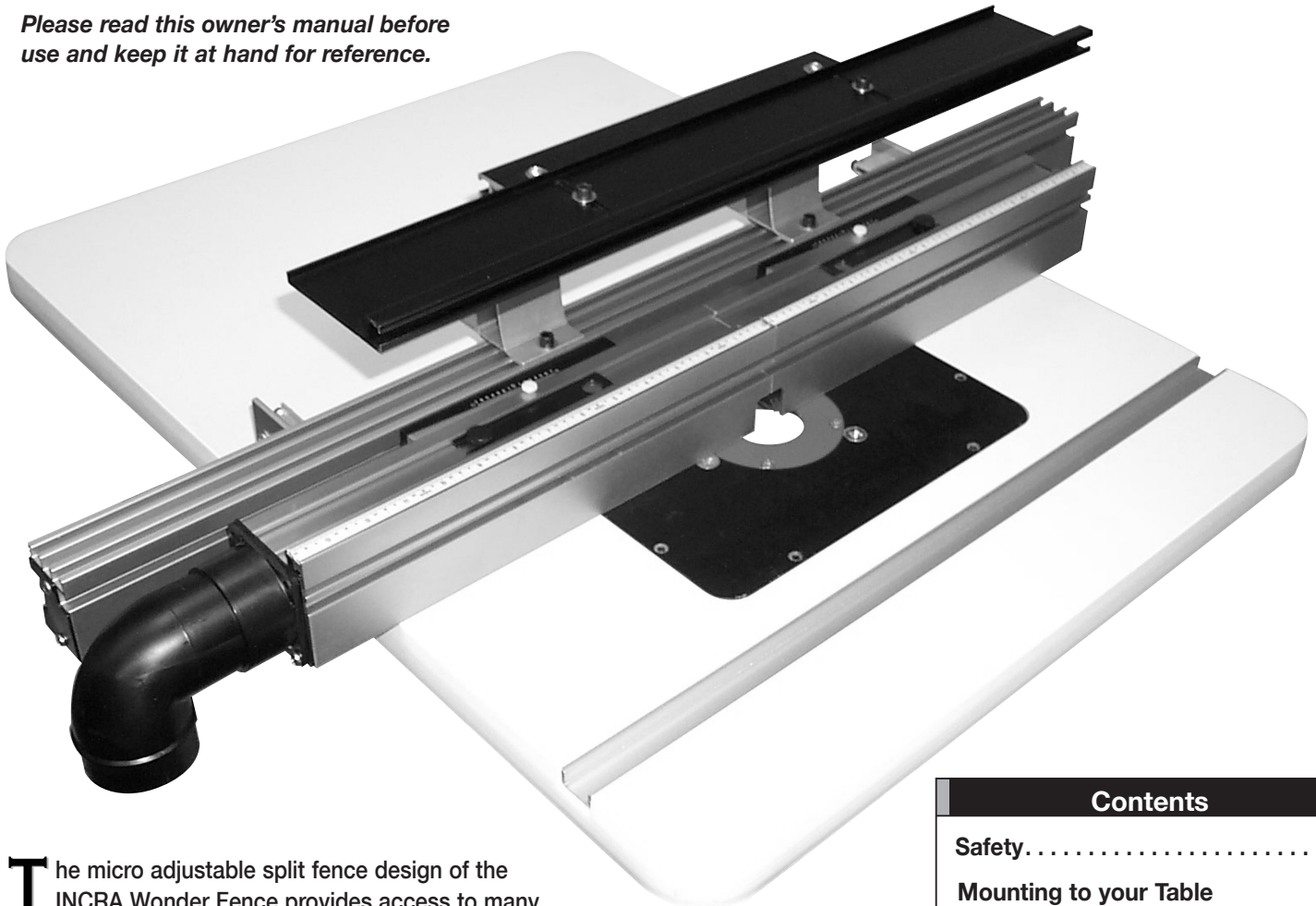

**T**he micro adjustable split fence design of the INCRA Wonder Fence provides access to many operations previously reserved for specialty machines. From the straight edge cutting abilities of the jointer to the many edge forming functions performed by the shaper, your new Wonder Fence offers a host of exciting new possibilities for your router table.

It all starts with intelligent design features. The opposing wedge design of the infeed/outfeed offset mechanisms permits very fine continuous adjustments of the fence offset from zero to 1/8", and each offset mechanism has its own cursor and scale marked off in 2/1000" increments. With the included table clamps, you can use the INCRA Wonder Fence as a free-standing router table fence or you can mount it directly to the INCRA Jig Ultra for the ultimate router table fence setup. If you have purchased the TS/Wonder Fence table saw fence upgrade kit, you can mount the fences directly to your INCRA TS table saw fence for use with a router table extension wing. The unique Hi-Rise™ fence cap and an adjustable fence opening take the hassle out of working with large panels and large diameter router bits for panel raising operations. The Wonder Fence is also compatible with all INCRA joint-making accessories including the INCRA Right Angle Fixture, INCRA Stop and INCRA Shop Stop. All these features combined with the universal dust collection port make the INCRA Wonder Fence the intelligent choice for your router table station.

Contents	
Safety.....	2
<b>Mounting to your Table</b>	
Freestanding Mode .....	2
Attaching to your INCRA Jig ..	3
Attaching to your INCRA TS ..	3
<b>Operation</b>	
Calibration .....	4
Offset Adjustment .....	5
Gap Adjustment.....	5
<b>In-line Fence Applications</b>	
Vertical Panel Raising .....	6
Joint Making .....	6
<b>Offset Fence Applications</b>	
Jointing .....	7
Shaping .....	7
<b>Zero Clearance Subfences</b>	8
<b>Hi-Rise Fence Cap</b>	10
<b>Fence Squaring Adjustment</b>	11

## Safety

Important safety instructions for using the INCRA Wonder Fence:

- When using the INCRA TS/Wonder Fence table saw fence upgrade kit in conjunction with your INCRA-TS table saw model, ALWAYS remove the Wonder Fence before making any cuts with your table saw blade.
- Never attempt any cut with your table saw blade while the Wonder Fence is installed on your TS fence.
- Before using the INCRA Wonder Fence, read and follow all of the instructions and safety information in this manual.
- When using the INCRA Wonder Fence in conjunction with any other tool, first read and follow all instructions and safety information in that tool's manual.
- Use appropriate safety devices. Always use a push stick, rubber soled push block, or other safety devices to keep your hands safely away from the cutting tool.
- When used in the free-standing mode with the supplied table clamps, always make sure the clamping knobs are tightened securely in place before making any cuts.
- If attaching the INCRA Wonder Fence to your INCRA Jig Ultra, always make sure the carriage clamp on the Incra Jig is in the locked position and the base is held securely in place before making any cuts.
- Always turn off the power and make sure that the router bit has come to a complete stop before changing the setting of any part of the INCRA Wonder Fence.
- When adjusting the fence opening, never position the infeed or outfeed fence ends closer than  $\frac{1}{8}$ " from the router bit.
- After making adjustments to the fence positions, be sure to tighten the two socket head cap screws through the large holes in both the infeed and outfeed fences.
- When using fence settings in which the router bit is partially recessed in the fence opening, always insure that the bit is centered within the opening.
- Never let the router bit come into contact with the aluminum body of the INCRA Wonder Fence.
- Whenever using large diameter vertical or horizontal panel raising bits or any other large diameter bit, always follow that router bit manufacturer's operation and safety recommendations.
- Whenever it is necessary to remove large amounts of stock, always use multiple side-by-side passes to achieve the final cut. Several shallow cuts are safer and will yield better results.

## Mounting Instructions for your INCRA Wonder Fence

Your new INCRA Wonder Fence can be used either by clamping directly to the router table (freestanding mode) or by attaching first to your INCRA Jig Ultra (router table model). If you have purchased the TS/Wonder Fence table saw fence upgrade kit, you'll be attaching the Wonder Fence directly to the TS fence for use with your router table extension wing. Find the instructions to follow that cover your application.

### Freestanding Mode

(Shown in photo on front cover)

#### Attach table clamps and clamp to router table

Position the Wonder Fence on your router table with the opening in the fence centered on your router collet. Loosen the  $\frac{1}{4}$ -20 x 2" socket head cap screw located on each of the (2) table clamps using the supplied hex tool. Now slide the rectangular nut on the table clamp into the upper T-slot on the rear of the Wonder Fence (Fig.-1). Slide the table clamp to the edge of your table and clamp in place. Repeat for the second clamp at the opposite edge of the router table. Tighten both socket head cap screws using the supplied hex tool. **Detail 1**

Fig. 1 Attach table clamps

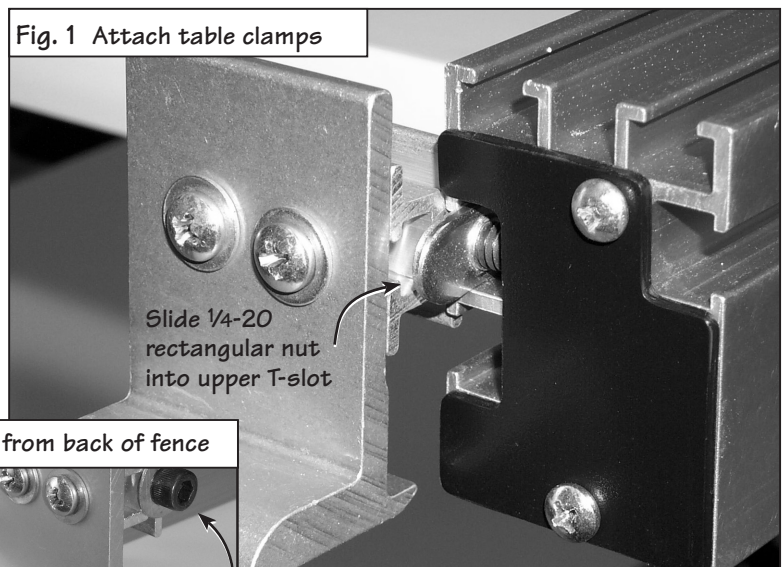

Slide  $\frac{1}{4}$ -20 rectangular nut into upper T-slot

Detail 1 View from back of fence

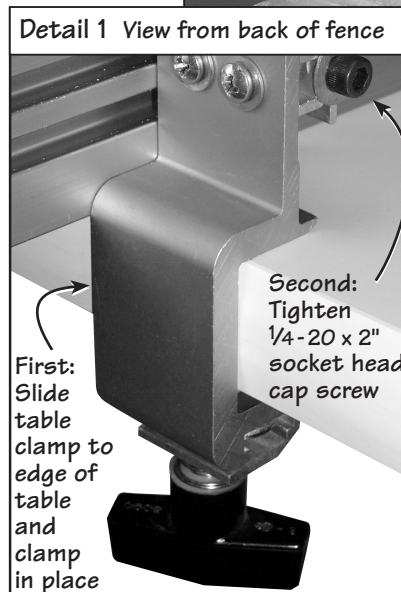

First: Slide table clamp to edge of table and clamp in place

Second: Tighten  $\frac{1}{4}$ -20 x 2" socket head cap screw

**NOTE:** The table clamps are designed to work on router tables from  $1\frac{1}{8}$ " to  $1\frac{3}{8}$ " thick. To increase the thickness of a table less than  $1\frac{1}{8}$ " thick, use double faced tape to attach a wooden strip to the underside of the table edge.

**TIP**

The fence angle can be adjusted perfectly square to your router table by loosening the two phillips head screws on the table clamps.

## ATTACHING TO YOUR INCRA JIG ULTRA (Router Table Model, shown in Fig 12, page 6)

**IMPORTANT:** Your Incra Jig Ultra must be mounted to a  $\frac{3}{4}$ " thick wooden base and the carriage clamp must be in the locked position before installing the Wonder Fence.

### Attach Wonder Fence to the Ultra

Place a thick gold washer ( $\frac{5}{8}$ " o.d.) on each of the (2) #10-32 x-1  $\frac{1}{8}$ " phillips head screws. Insert one screw through each of the two slotted holes on the fence mounting bracket and loosely thread on the #10-32-rectangular nuts as shown in Fig. 2.

Now slide the rectangular nuts into the upper T-slot located on the rear of the Wonder Fence. Position the opening between the two fence halves directly over your router collet, then tighten mounting screws.

Fig. 2  
Attach Wonder Fence to ULTRA

ULTRA Fence mounting bracket  
#10-32 x 1  $\frac{1}{8}$ " phillips head screw with  $\frac{5}{8}$ " o.d. gold washer

#10-32 rectangular nut slides into upper T-slot on rear of Wonder Fence

## Attaching to your INCRA TS (Table Saw Model)

**CAUTION:** When using the Wonder Fence in conjunction with your INCRA TS table saw model, ALWAYS remove the Wonder Fence before making cuts with your table saw blade. Never attempt any cut with your table saw blade with the Wonder Fence installed on your TS Fence.

Fig. 3  
Loosen fasteners

Use hex tool to loosen fasteners through the two larger holes

Fig. 4  
Slide view panel

Do not remove rectangular nuts

Thumbscrew

Slide view panel to see cap screws

Fig. 5  
Slide Wonder Fence onto the TS Fence

With a router table extension wing in place at your table saw, you'll find adding the TS-Wonder Fence table saw fence upgrade kit to your INCRA TS fence creates a superior workstation for routing, jointing and shaping. Combined with the INCRA Right Angle Fixture, the INCRA Stop and the INCRA Master Reference Guide and Template Library, you'll also be able to create all of the exciting INCRA joinery.

### Loosen attachment fasteners

Insert the supplied hex tool through the (2) large diameter access holes located in the front of each Wonder Fence half and loosen the (2) socket head cap screws. (Do not remove the rectangular nuts.) For a better view of the fasteners, loosen the thumbscrew and slide the black plastic view panel located on the top of each fence half. See Figs. 3 and 4.

### Slide Wonder Fence into position on TS Fence

Slide the two rectangular nuts on each Wonder Fence half into the T-slot located on the front face of the TS Fence. Position the Wonder Fence so that your router collet is centered in the opening between the fences, then tighten the two socket head cap screws on each fence half. Slide the view panel back in place and tighten the thumbscrew. See Fig. 5.

## OPERATION

The infeed and outfeed fences of the Wonder Fence can be moved independently in two directions to provide a variety of setup configurations. By making the **offset adjustments** described on page 5, you can position the fences “in-line” for standard operations such as grooving, rabbeting, or joint-making, or you can “offset” the infeed and outfeed fences for speciality cutting applications such as shaping or jointing an edge. The **gap adjustment** allows adjustment of the opening between the infeed and outfeed fences. Follow the step-by-step instructions below to first calibrate your Wonder Fence, then follow the step-by-step procedures in the offset and gap adjustment sections to familiarize yourself with these two important functions shown in Fig. 6.

Fig. 6  
Offset and gap adjustments

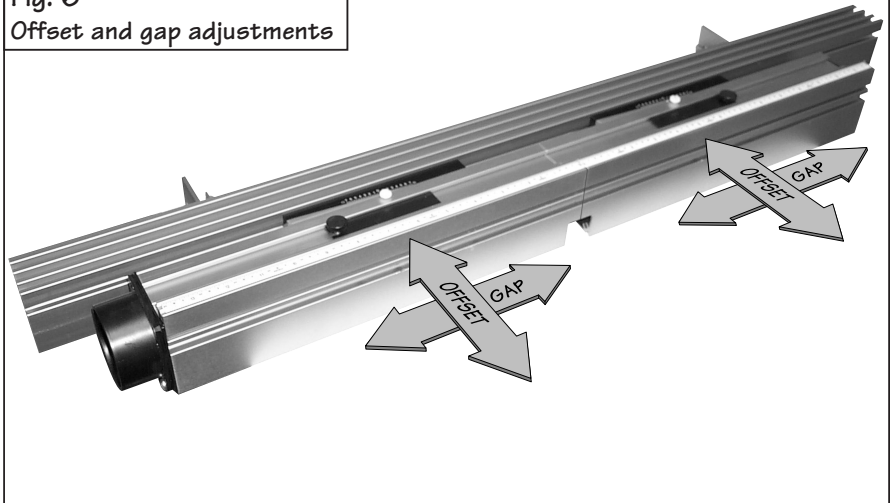

### Calibration: In-line/mid-range Position

In order for the etched scales on the two black rear wedges to provide an accurate readout of fence offset, the two fences must first be positioned in-line with one another with the adjustment wedges at mid-range. The two cursors can then be positioned to read zero on the wedge scales. Once these cursors are set, you’ll find it easy to return the fences to the in-line/mid-range position for standard in-line fence applications. Here’s how.

Fig. 7 Calibration: In-line/mid-range position

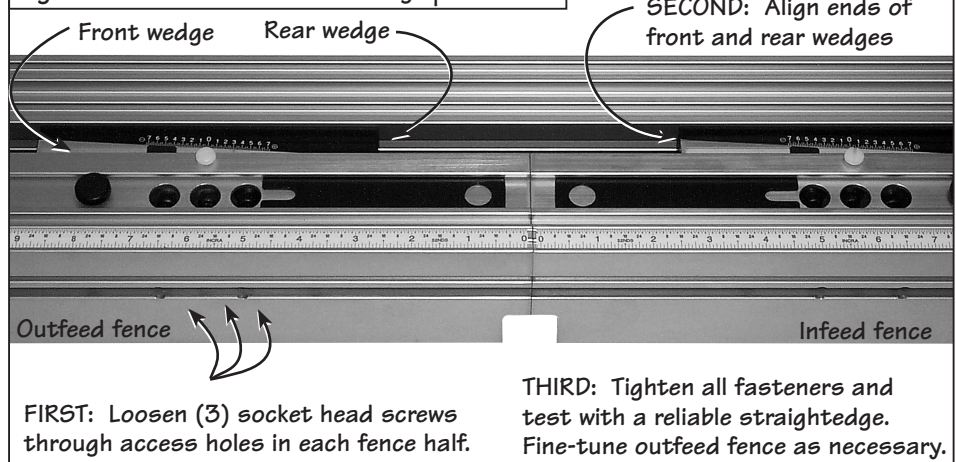

**1** Referring to Fig. 7, use the supplied hex key to loosen the two socket head screws through the large holes in the front of each Wonder Fence half. Also loosen the wedge locking screw. The access hole for the wedge locking screw is located between the two large holes. For a clear view of the screw heads, loosen the thumbscrew and slide the black view panel located on the top of the Wonder Fence. Loosen each of the (3) screws one full turn.

**2** Slide the black rear wedge on each fence to align the ends of the rear wedge flush with the ends of the front wedge. This positions the wedges at mid-range. **CAUTION:** To avoid disengaging the nut, do not loosen any of the socket head screws more than one or two full turns.

**3** Tighten all fasteners, then test the in-line setup by sliding a straightedge down the length of the fences. If any offset exists, fine-tune by adjusting the wedges on the outfeed fence. **Make sure to tighten all fasteners after each adjustment.**

**4** Once the fences are located in-line with one another, loosen the nylon screw that secures the cursor on each fence half and slide the cursor to point to “0” on the etched scale, Fig. 8.

Fig. 8  
Slide cursor to read “0”

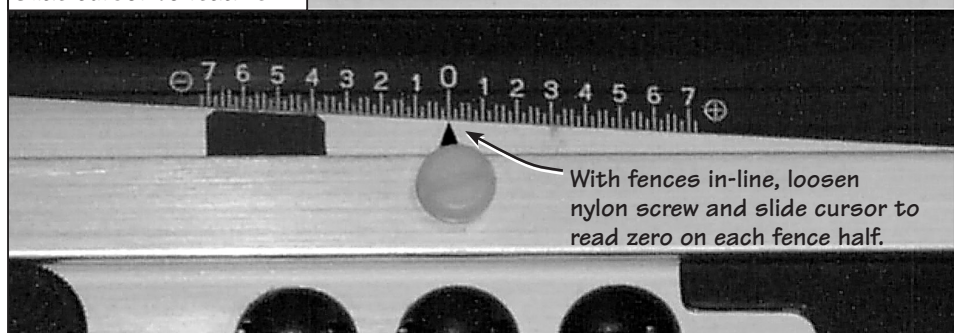

## Offset Adjustment

Follow these steps to adjust either the infeed or outfeed fence for “in-line” or “offset” fence applications. See Fig. 9.

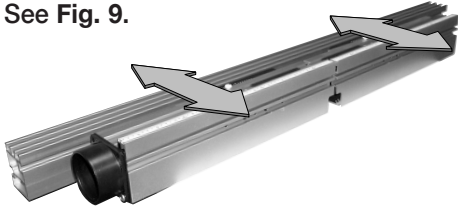

**CAUTION:** To avoid disengaging the nut, do not loosen any of the socket head screws more than one or two full turns.

**1** Using the supplied hex tool, loosen the two socket head screws through the large holes in the front of the Wonder Fence half. Also loosen the wedge locking screw. The access hole for the wedge locking screw is located between the two large holes. Loosen each of the (3) screws one to two full turns depending on the amount of adjustment range needed. For a clear view of the screw heads, loosen the thumbscrew and slide the black view panel located on the top of the Wonder Fence.

Fig. 9  
Offset adjustment

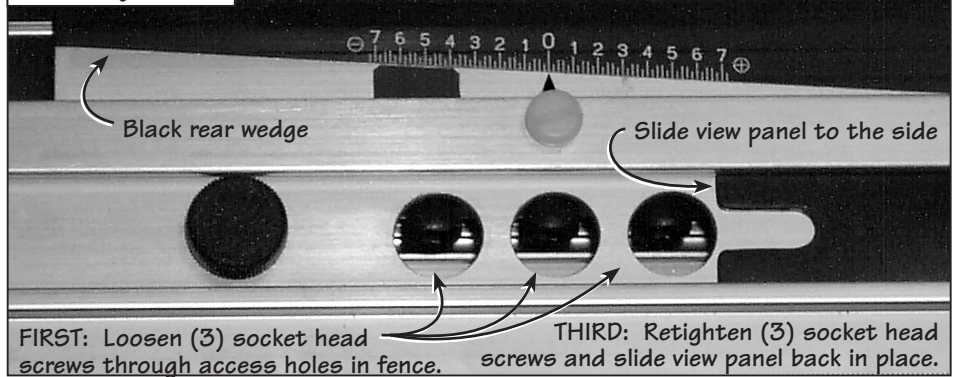

SECOND: Slide black rear wedge left to move fence forward or right to move fence backward.

FIRST: Loosen (3) socket head screws through access holes in fence.

THIRD: Retighten (3) socket head screws and slide view panel back in place.

**2** Adjust the fence by sliding the black rear wedge:

**+** To move the fence forward, slide the wedge to the left. (This moves the **+** end of the scale towards the cursor.)

**-** To move the fence backward, slide the wedge to the right. (This moves the **-** end of the scale towards the cursor.)

**3** Tighten the three socket head cap screws to secure the fence position then slide the view panel back in place and tighten the thumbscrew.

**NOTE:** The numbers on the scale represent hundredths of an inch fence offset. Each of the smaller tick marks on the scale represent .002" (2 thousandths of an inch).

## Gap Adjustment

Follow these steps to adjust the opening between the infeed and outfeed fences, see Fig 10.

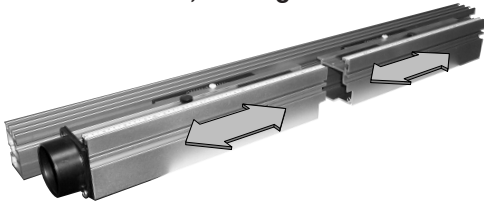

**CAUTION:** When adjusting the fence gap, never position the ends of the aluminum fences closer than 1/8" from the router bit.

**1** Using the supplied hex key, loosen the two socket head screws through the large access holes located in the front of each Wonder Fence half. DO NOT loosen the wedge locking screw located between the two large holes. For a clear view of the screw heads, loosen the thumbscrews and slide the black view panels located on the top of each half of the Wonder Fence.

Fig. 10  
Gap adjustment

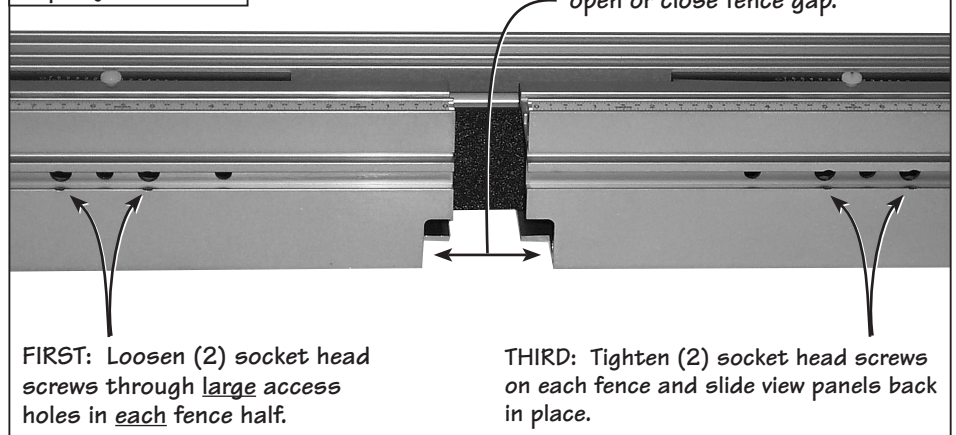

SECOND: Slide fences to open or close fence gap.

FIRST: Loosen (2) socket head screws through large access holes in each fence half.

THIRD: Tighten (2) socket head screws on each fence and slide view panels back in place.

**2** Slide the infeed and/or outfeed fences to open or close the fence gap.

**3** Tighten the two socket head screws on each fence half, then slide the view panels back in place and tighten the thumbscrews.

## In-line Fence Applications

Once set to the in-line/mid-range position as described on page 4, your new INCRA Wonder Fence can be used for a variety of typical in-line fence applications, including grooving, dadoing, and edge forming operations

such as rabbeting, chamfering, and roundovers. You'll also find the in-line position useful for many specialty operations. With the Hi-Rise fence cap, you'll be able to use vertical panel raising bits to make raised

panels for cabinetry, and since its design is compatible with all INCRA joint-making accessories, you'll be able to use the Wonder Fence in conjunction with your INCRA Jig Ultra as a joint-making fence.

## Vertical Panel Raising

The introduction of the vertical panel raising bit has made cutting the reveal on a raised panel a relatively simple operation for the router table. You'll find your new Wonder Fence, with its built-in dust collection, adjustable fence gap, and Hi-Rise fence cap, perfect for this operation. The setup is as follows: Fig. 11:

- 1** Install vertical panel raising bit and set appropriate depth of cut.
- 2** Adjust fence gap as necessary (see Gap Adjustment on page 5).

**3** Adjust infeed/outfeed fences to the in-line/mid-range position as described on page 4.

**4** Use a straightedge to adjust the Hi-Rise fence cap in line with the infeed and outfeed fences. (See page 10)

**5** Remember: Do not make the full width of the cut in a single pass. Instead, use several light side-by-side passes, moving the fence back 1/16" or so after each pass.

Fig. 11  
Vertical panel raising



### Safety

- Whenever using large diameter vertical or horizontal panel raising bits or any other large diameter bit, always follow that router bit manufacturer's operation and safety recommendations.
- Whenever it is necessary to remove large amounts of stock, always use multiple side-by-side passes to achieve the final cut. Several shallow cuts are safer and will yield better results.

## Joint Making (INCRA Jig Ultra required)

Adding an INCRA Jig Ultra to your Wonder Fence makes precise placement of multiple side-by-side cuts a cinch. One such operation requiring this kind of precision is joint making. Once placed in the in-line/mid-range position, your new Wonder Fence becomes a perfect replacement for the standard straight fence commonly used with the INCRA Jig. It is completely compatible with all of the INCRA joint-making accessories, including the INCRA Right Angle Fixture, Stop, and joinery templates. The setup follows, see Fig. 12:

- 1** Adjust infeed/outfeed fences to the in-line/mid-range position, see page 4.
- 2** Adjust fence gap as described on page 5.
- 3** Follow the instructions for the joint you wish to cut as detailed in the *INCRA Master Reference Guide and Template Library*.

**TIP**

Clearance is provided for between the Hi-Rise fence cap, the braces and all INCRA joint-making accessories. However, since the Hi-Rise fence cap and braces are not necessary for joinery, you may remove them from the Wonder Fence if you prefer. Just loosen the (2) socket head fasteners that secure the fence cap braces, and slide the assembly off of the Wonder Fence.

Fig. 12  
Joint Making

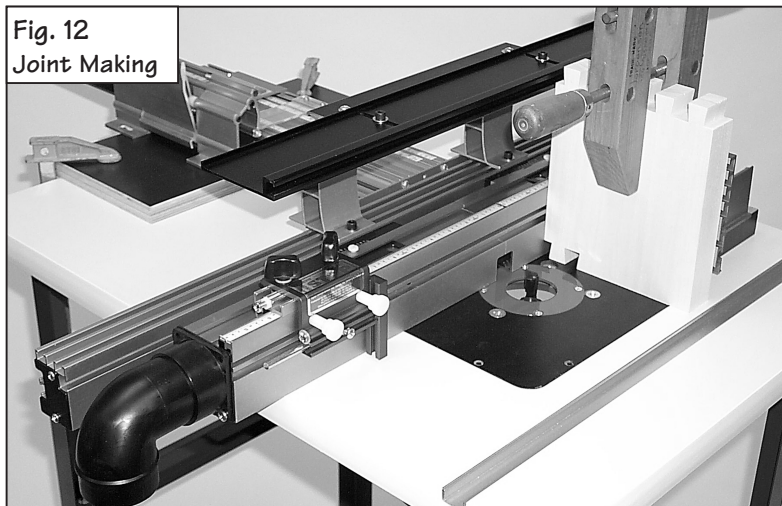

## Offset Fence Applications

One of the most valuable features of the Wonder Fence is the ability to offset the infeed and outfeed fences. The offset fence adds a whole new dimension to the router table, allowing it to perform two new operations – jointing, and shaping.

### Jointing

Most woodworking projects require that your boards begin with at least one straight edge. This one straight edge then becomes the reference surface for subsequent perpendicular or parallel cuts. By using your Wonder Fence and the technique described below, you'll be able to put a perfectly straight edge on your board at the router table and, because of the higher RPM of the router, you'll find the freshly jointed edge far smoother than any jointer machine can produce.

- 1** Install a 1/2" diameter (or larger) straight bit and set the depth of cut to slightly greater than the thickness of stock to be jointed.
- 2** Adjust fence gap as necessary (see Gap Adjustment on page 5).
- 3** Adjust infeed/outfeed fences to the in-line/ mid-range position as described on page 4.
- 4** Adjust the location of the Wonder Fence at your router table to place the outfeed fence in line with the outermost cutting arc of the router bit. (A straightedge placed against the outfeed fence can be used to help align the fence with the cutter.) Fig. 14.
- 5** Micro adjust the infeed fence backward (-). The reading on the scale will represent the amount of stock you wish to remove from the board's edge on each pass. A light cut (infeed cursor reading between -1 and -2) will yield the smoothest results.

### Shaping

Many shaping operations involve the removal of the entire edge of a square piece of stock as it is moved past the cutter. Once the stock is removed from the edge, it becomes necessary to support the freshly cut surface by moving the outfeed fence forward. Although similar to jointing, the setup is slightly different. Here's how:

- 1** Install router bit and set desired depth of cut.
- 2** Adjust fence gap as necessary (see Gap Adjustment on page 5).
- 3** Adjust infeed/outfeed fences to the in-line/mid-range position as described on page 4.
- 4** Adjust the location of the Wonder Fence at your router table to achieve the desired cut profile. Use a scrap piece of wood and make trial cuts to help in determining the fence position.
- 5** Make a fresh test cut about 3" long on a piece of scrap stock, then turn off the router. You'll notice a gap between the freshly cut surface and the outfeed fence, Fig. 16. Simply micro adjust the outfeed fence forward by this amount to support the stock's edge as it passes the cutter.

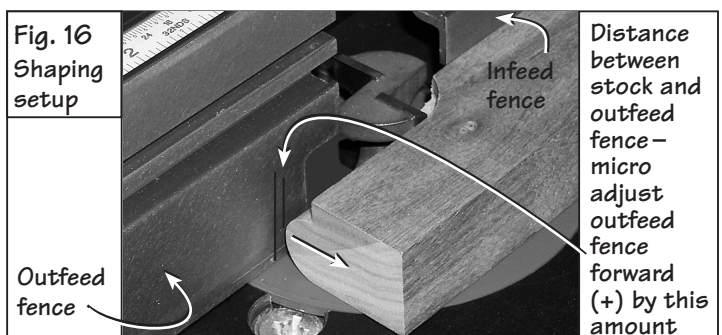
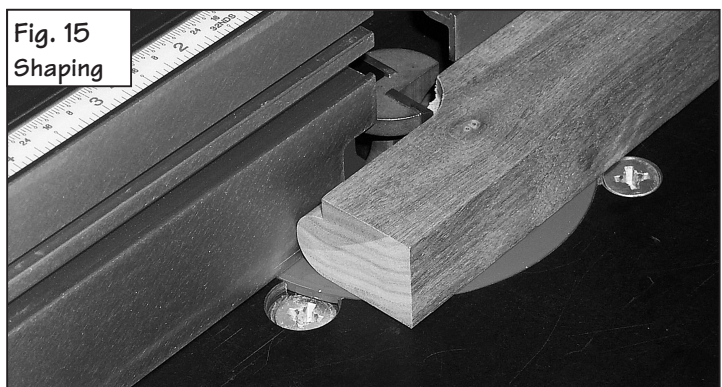
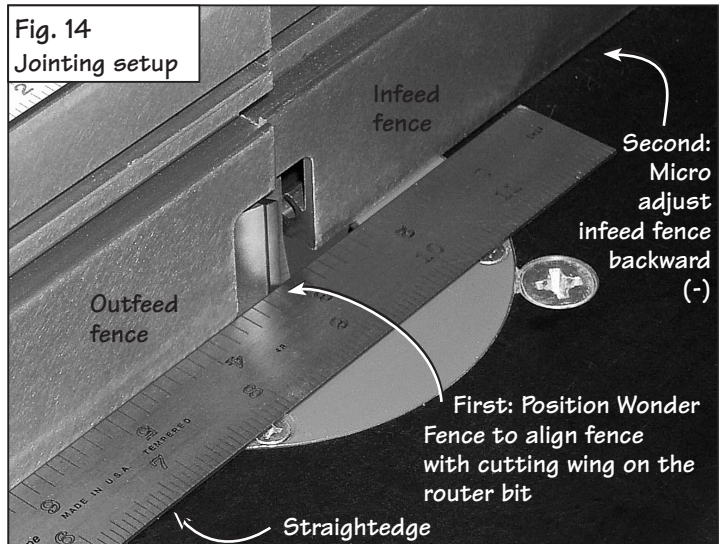
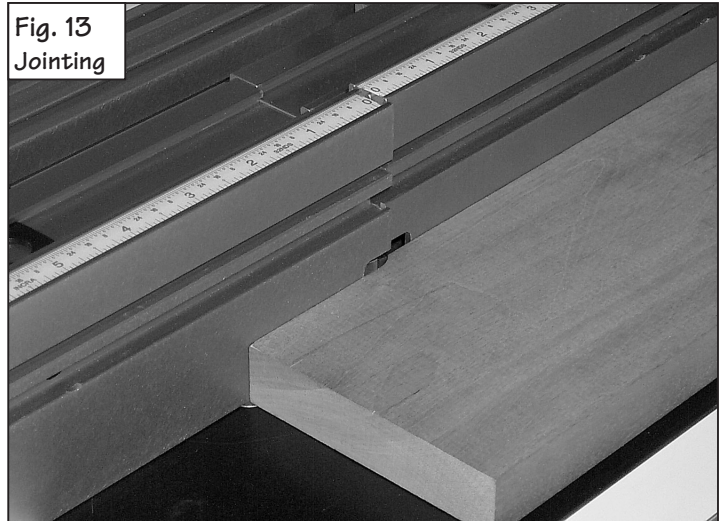

## Zero Clearance Subfences

Adding a zero clearance subfence to your Wonder Fence is a perfect solution to providing tearout control and additional support for your workpiece when using large diameter cutters. Typically a zero clearance subfence is a long piece of wood with the profile of a particular cutter bandsawn into the face. When attached to the router table fence and moved into position, the router bit nestles into the cutout. This close fit around the cutter provides the tearout control and support for your workpiece, Fig. 17. Here's how to prepare a zero clearance subfence for your Wonder Fence:

### Making a zero clearance subfence blank

**1** Begin with one piece of  $\frac{3}{4}$ " medium density fiberboard  $3\frac{1}{16}$ " x 32". Layout the drill and counterbore centers as shown in Fig.-18, then cut to the length as shown. Drill and counterbore at each center mark using the dimensions in Detail-18.

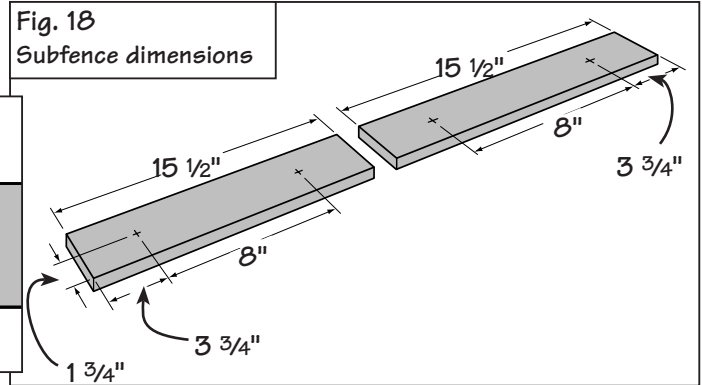
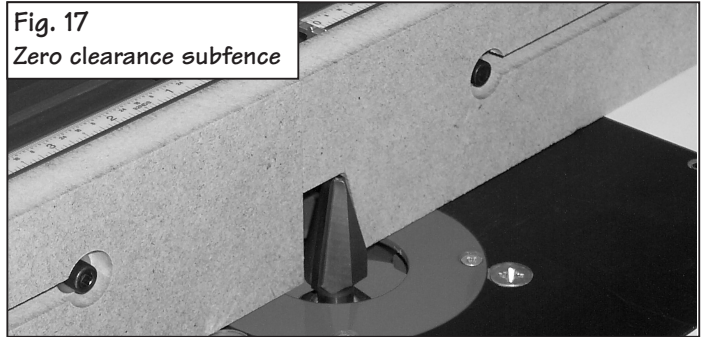
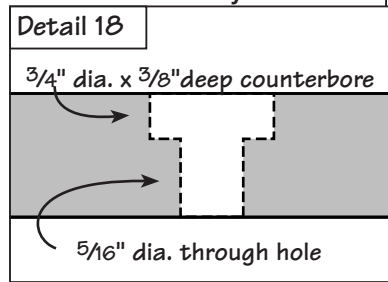

### 2 Connect the through holes with a slot

In order to later access the fence offset adjustment screws on your Wonder Fence, you'll need to connect the through holes on your zero clearance fence halves with a slot. See Fig 19. Install a  $\frac{5}{16}$ " straight bit in your router table and set the depth of cut to  $\frac{1}{4}$ ". Position your fence so that the router bit will nestle into the through hole located at one end of the subfence. Clamp a stop on your infeed fence against the end of the zero clearance fence. Lift the zero clearance fence off of the router and place the end of the zero clearance fence against the stop. Now slowly lower the piece onto the cutter. Slide the zero clearance fence forward until the router bit is seen entering the rear hole. Slide the piece back to the starting position and turn off the router.

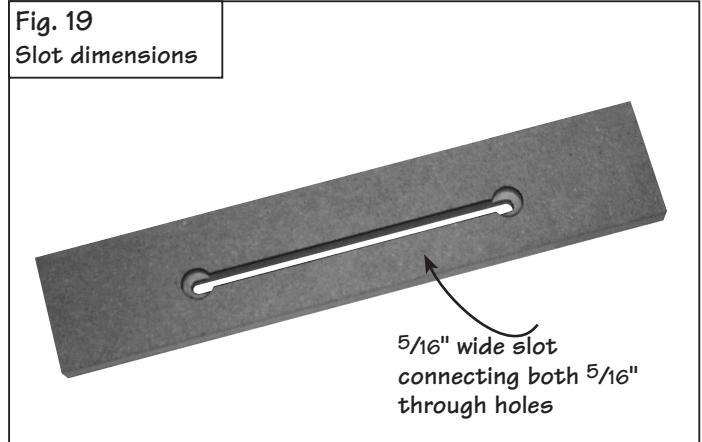

**TIP**

To make this cutting operation safer, use double-faced tape to attach a scrap block of wood to the zero clearance fence. The scrap can be used as a handle to safely raise and lower the stock.

Repeat this cut for the other zero clearance fence. Next, increase the depth of cut by  $\frac{1}{4}$ " and repeat the cutting process for both pieces. Finally raise the bit to cut completely through the stock and repeat the cuts.

Fig. 20  
Connect through holes with slot

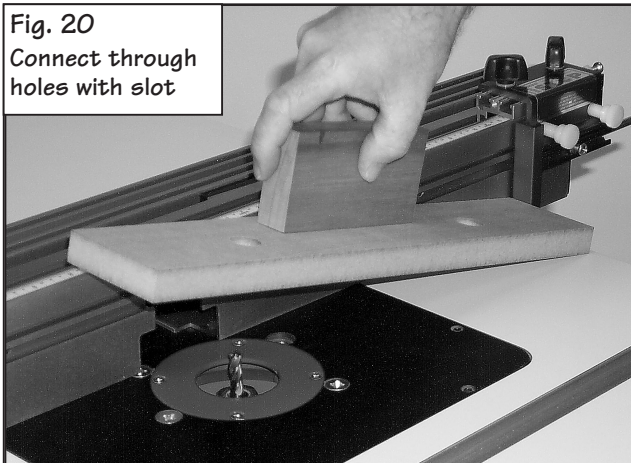

First: Turn on router and lower stock onto cutter

Second: Slide stock forward. Stop cut when router bit is seen entering rear hole.

Third: Slide stock back to starting position and turn off router.

**CAUTION:** The cutter will be cutting through the top of the stock. Keep your fingers clear of the line of cut. (See TIP above and Fig. 20.)

1<sup>st</sup> Pass:  $\frac{5}{16}$ " diameter cutter,  $\frac{1}{4}$ " depth of cut  
 2<sup>nd</sup> Pass:  $\frac{1}{2}$ " depth of cut  
 3<sup>rd</sup> Pass:  $\frac{3}{4}$ " depth of cut

Double face tape holds scrap of wood to stock for use as handle



## Cutting the Zero Clearance Profile

### 1 Attach subfences to infeed and outfeed fences.

Place a washer on each of the (4) 1/4-20-x 3/4" socket head cap screws provided and insert into the counterbores. Loosely thread on the 1/4-20 rectangular nuts, then slide the nuts into the T-slot located on the front of the Wonder Fence. Both subfences must be inserted from the end of the infeed fence. Slide both subfences to align the ends flush with the ends of the aluminum fences (nearest the cut area) and tighten the fasteners. Fig. 21.

Fig. 21

Attach subfences

Slide 1/4-20 rectangular nut into T-slot on Wonder Fence

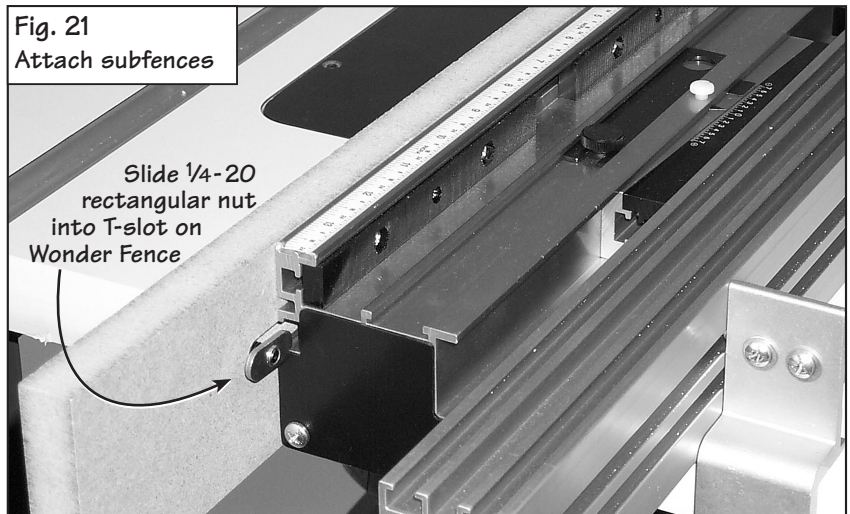

### 2 Position fence for initial profile cutting

Install desired cutter and set the fence gap as described on page 5. The fence ends should be no closer than 1/8" from the cutter. Tighten the fasteners. Slide the entire Wonder Fence up to the cutter and position it so the rear face of the subfence is in front of the center of the cutter. See overhead view, Fig. 22. Lock your Inkra Jig's carriage clamp or, if using the Wonder Fence in the freestanding mode, tighten the two table clamps.

Fig. 22

Position fence for initial cut

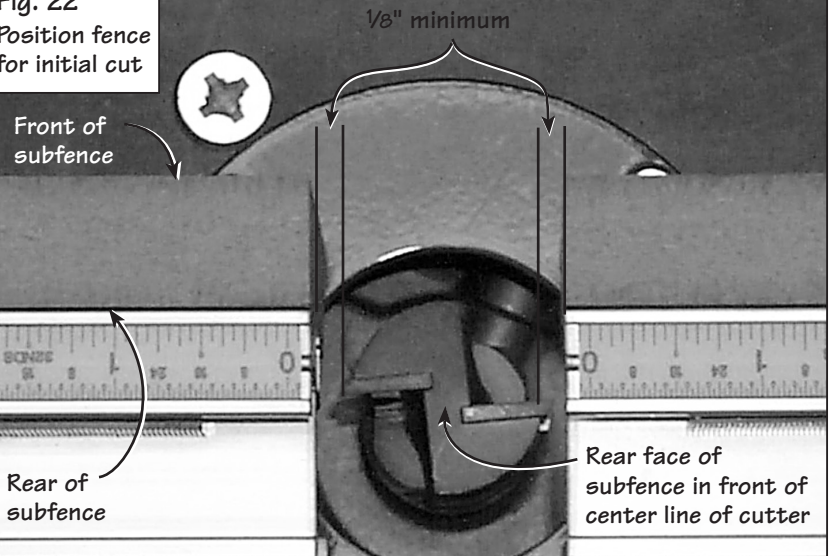

### 3 Make the profiling cuts

Loosen the two socket head cap screws that secure the infeed subfence. Now turn on the router and, using a good rubber soled push block, advance the subfence forward into the cut. When the subfence touches the outfeed fence (or the bearing on some cutters), back the subfence out of the cut and turn off the router. Unlock your Inkra Jig, or loosen the table clamps if using in the freestanding mode, and move the Wonder Fence back 1/8". Relock the clamps, then repeat the cut. Continue this process until you have cut completely through the subfence.

**CAUTION:** The nature of zero clearance places the subfence very close to the cutter. NEVER attempt to move your fence or make any adjustment to the setup until the router bit has come to a complete stop.

### 4 Slide the subfence into final position

Now you can slide the completed subfence into its final position on the infeed fence and tighten the mounting screws. Final positioning should always be done with the router turned off and the carriage clamp locked.

## Hi-Rise Fence Cap

You'll find the Hi-Rise fence cap great for supporting large vertical panel work. Here's how to attach the Fence Cap and braces.

### 1 Attach the fence cap braces

Place a 1/4" washer on each of (2) 1/4-20 x 1/2" socket head cap screws and insert through the hole on the front of each fence brace. Loosely thread on a 1/4-20 rectangular nut (the raised rim on the nut should face away from the brace), then slide the nut into the forward T-slot located in the top of the Wonder Fence assembly. See Fig.-23 and Detail 23. Locate the two braces on the fence 7 5/8" apart. Tighten the fasteners with the supplied hex tool.

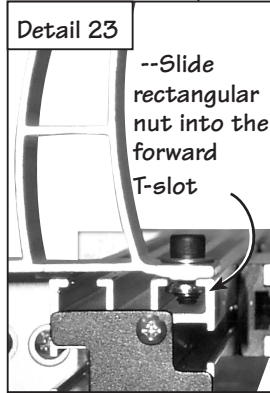

Fig. 23 Attach fence cap braces

1/4 -20 x 1/2" socket head cap screw with 1/4" washer

Fence cap brace

Forward T-slot

7 5/8"

### 2 Attach the cap extender

Place a 1/4" washer on each of the (2) pan head phillips screws and insert through the slotted holes located in the fence cap extender. Loosely thread a #10-32 hex nut onto each fastener, then slide the hex nuts into the T-slot located on the top of each fence cap brace. Position the cap extender so you can later gain access to the socket head fasteners on each fence cap brace through the slotted holes. Pull the cap extender forward until it firmly contacts the back of each brace and tighten the (2) phillips head screws. See Fig.-24 and Detail 24.

Fig. 24

Attach cap extender

#10-32 x 1/2" phillips screw with 1/4" washer

Second: Position cap extender to allow future access to socket head cap screws through slotted hole.

First: Insert fasteners and slide #10-32 hex nuts into T-slot on top of braces

Detail 24

Cap extender

Third: Slide cap extender forward to contact brace, then tighten screws

Fence cap extender

Brace

### 3 Attach and align fence cap

Place the 24" long fence cap on top of the cap extender and attach using the (2) 1/4-20 x 5/8" socket head cap screws with 1/4" washers and lock nuts. Use a straightedge to align the leading edge of the fence cap with the front face of the Wonder Fence and tighten the two cap mounting screws. See Fig. 25. To remove the fence cap and braces, just loosen the two socket head cap screws that secure the braces and slide the entire assembly off of the Wonder Fence.

Fig. 25

Attach and align fence cap

Extend fence cap out to touch straight edge

FIRST: Attach fence cap to cap extender with (2) 1/4-20 x 5/8" socket head screws, washers and lock nuts

Fence cap

SECOND: Use a straightedge to align fence cap with Wonder Fence, then tighten fasteners.

**NOTE:** When removing the fence cap assembly from the INCRA TS Tablesaw Fence, loosen the fasteners and tilt the assembly to clear the fence mounting bracket.

# TIP

The fence and Hi-Rise fence cap provide the support necessary for large vertical panel work. If you want to add an auxiliary fence to bridge the gap between the two, use the drill and counterbore dimensions shown in the illustration. Use 1/4-20 x 3/4" machine screws with washers and hex nuts to attach the auxiliary-fence.

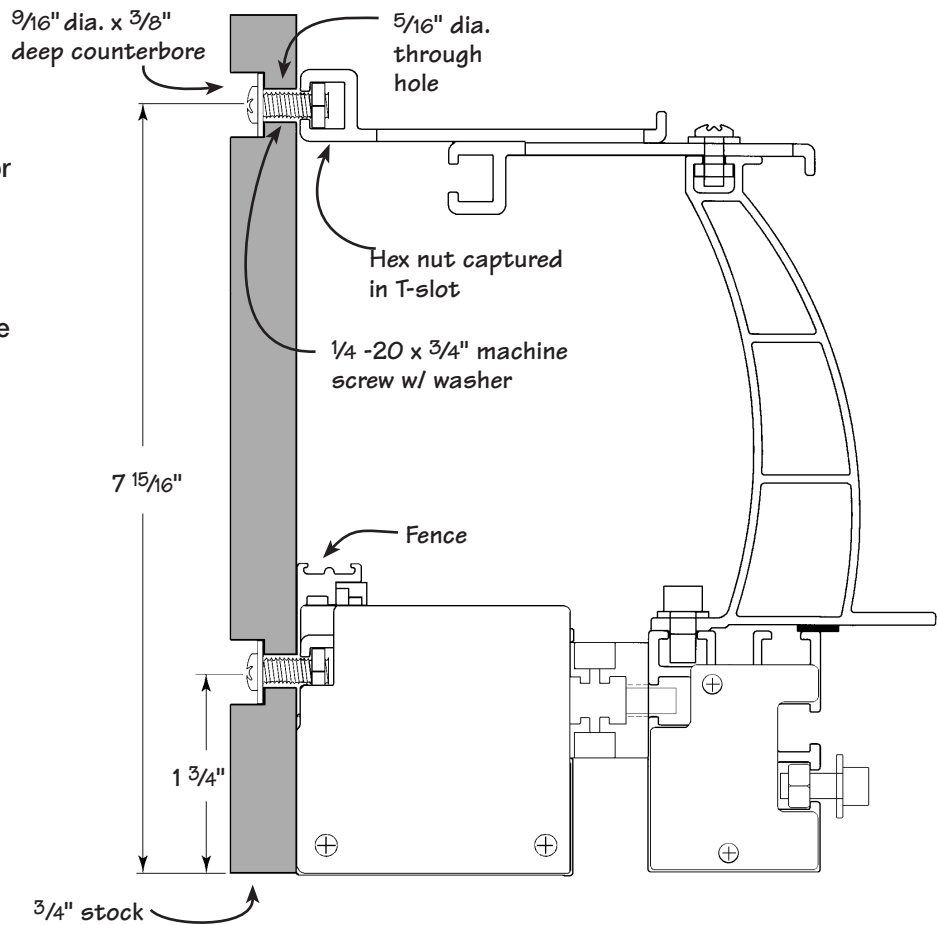

## Fence Squaring Adjustments

To adjust the angle of the fence perfectly square with your router table, loosen all five of the socket head screws through the holes in the front face of each Wonder Fence half. Slide one or more of the supplied plastic shims between the gold wedge and the rear of the fence. Place the shim above the fasteners to decrease the angle. Place the shim below the fasteners to increase the angle. Tighten all fasteners.

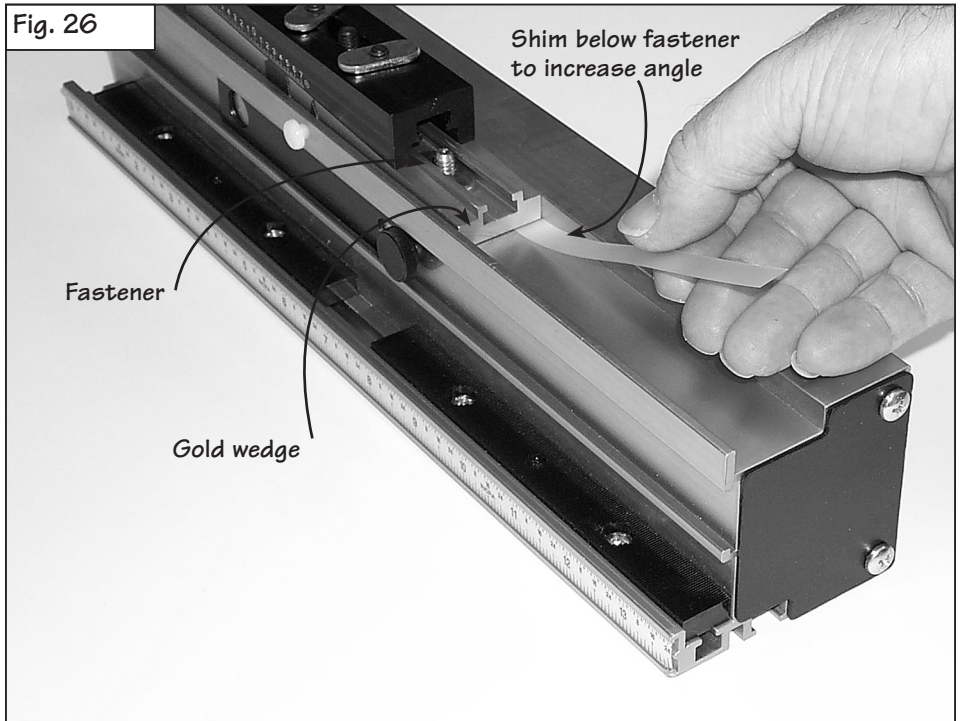

# WARRANTY

Taylor Design Group, Inc. warrants this product for one year from date of purchase. We will repair any defects due to faulty material or workmanship, or at our option, replace the product free of charge. Please return the failing component only, postage prepaid, along with a description of the problem to the address below. This warranty does not apply to parts which have been subjected to improper use, alteration, or abuse.

## LIFETIME WARRANTY ON POSITIONING RACKS

If an INCRA positioning rack in this tool becomes damaged for ANY reason, Taylor Design Group will replace it free of charge for as long as you own your tool. Return the damaged rack, postage prepaid, and allow 1 to 2 weeks for delivery.

### NOTE:

Replacements cannot be sent unless damaged racks have been received by Taylor Design Group at P.O. Box 810262, Dallas, TX 75381

*For a product information brochure, call, write or fax to:*

**Taylor Design Group, Inc.**  
**P.O. Box 810262, Dallas, TX 75381**  
**Tel: (972) 242-9975**  
**Fax: (972) 242-9985**

**Or for the most up to date product information see our web site:**  
**[www.incra.com](http://www.incra.com)**

For a product information update on the complete INCRA line of tools, please see your nearest dealer.

If you are unable to locate a store nearby, or if you have trouble finding a particular product, we will honor your order directly.



**Scan this QR code to register your product online**

**You can also register your INCRA product online at [www.incra.com](http://www.incra.com).**

*It's quick and easy!*

**Made in America by:**

**Taylor Design Group, Inc. ■ P.O. Box 810262 ■ Dallas, Texas 75381**

01/20

Printed in the U.S.A.

© 2022 Taylor Design Group, Inc.

INCRA is a registered trademark of Taylor Design Group, Inc.