



# Owner's Manual Model DG6LN

## Air-cooled diesel engine generator set



## PREFACE

Thank you for purchasing products from EASTERNTOOLS & EQUIPMENT, INC. We appreciate your business. The following manual is only a guide to assist you and is not a complete or comprehensive manual of all aspects of maintaining and repairing your generator. The equipment you have purchased is a complex piece of machinery. We recommend that that you consult with a dealer if you have doubts or concerns as to your experience or ability to properly maintain or repair your equipment. You will save time and the inconvenience of having to go back to the store if you choose to write or call us concerning missing parts, service questions, operating advice, and/or assembly questions. Our air-cooled diesel generators have some of the following features:

- . Lightweight construction
- . Air cooled
- . Four-stroke diesel internal combustion engine
- . Direct fuel injection system
- . Electric starter
- . Large fuel tank
- . NFB circuit protector
- . AC outputs
- . Low oil pressure sensor

The ETQ air-cooled diesel generators are widely used when electrical power is scarce. Our generators provide a portable mobile solution in supplying power for field operations during project construction.

This manual will explain how to operate and service your generator set.

If you have any questions or suggestions about this manual, please contact your local dealer or us directly. ***Consumers should notice that this manual might differ slightly from the actual product as more improvements are made to our products. Some of the pictures in this manual may differ slightly from the actual product as well. Eastern Tools and Equipment, Inc. reserves the right to make changes at any time without notice and without incurring any obligation.***

## TABLE OF CONTENTS

	Page
Chapter 1 Technical Specifications and Data	1
1-1 Technical specifications and data	1
1-2 Basic operating parameters	2
1-3 General dimensions and overview of the generators	2
1-4 Electric wiring diagrams	3
Chapter 2 Operating the Diesel Generator	4
2-1 Main points of safety during operation of the generator	4
2-2 Preparation before operation	6
2-3 Checking the operation of the diesel engine	9
2-4 Starting the generator set	9
2-5 Proper operation of the generator set	12
2-6 Loading	12
2-7 Stopping the generator	13
Chapter 3 Maintenance	15
3-1 Maintenance schedules	15
3-2 Storing for long periods of time	17
Chapter 4 Troubleshooting	18
4-1 Troubleshooting procedures	18
4-2 Questions and doubts	18
Chapter 5 Generator Parts Diagrams and Listings	19
Limited Warranty	24
Product Registration Card	28
List for comments form users	29
Appendix	30
1.Attached list of tools,fittings,and subassemblies	30
2.Attached technical documents	30

## CHAPTER 1.TECHNICAL SPECIFICATIONS AND DATA

### 1-1 Technical specifications and data

		<b>DG6LN</b>	
<b>Generator</b>	Generator Type	2 electrode single-phase synchronous brushless alternator	
	Excitation	Self-excitation voltage	
	Voltage system	Condenser compensation system	
	Frequency	60 Hz	
	Rated power	5.0 Kw	
	Max power	5.5 Kw	
	AC Voltage	120/240 V	
	Speed	3600 rpm	
	Power factor(cosΦ)	1.0	
<b>Diesel Engine</b>	Engine model	ETQ186FA	
	Type	Single-cylinder,vertical,4-stroke,air-cooled,direct injection	
	Output	Continuous	6.7 Kw/9 HP
		Maximum	7.45 Kw/10 HP
	Bore×Stroke	86×72 mm/3.39×2.83 in	
	Displacement	418 cc/25.51 cu in	
	Lube-oil capacity	1.65 L/55.79 fl oz	
	Starting system	Electric start	
	Fuel tank capacity	12.5 L/3.3 gal	
	Net weight	157 kg/345 lb	
Dimensions(L×W×H)	915×535×740 mm/36.0×21.1×29.1 in		

### 1-2 Basic operating parameters

1-2.1 Under the given conditions, the generator will output the specified power in the table listed below.

Table 1.

Height above sea level (ft)	Ambient temperature (°F)	RH
0	+60 (+20 °C)	60%
<3280.8 (<1000 m)	41~104 (5-40 °C)	90%

### 1-3 General dimensions and overview of the generators

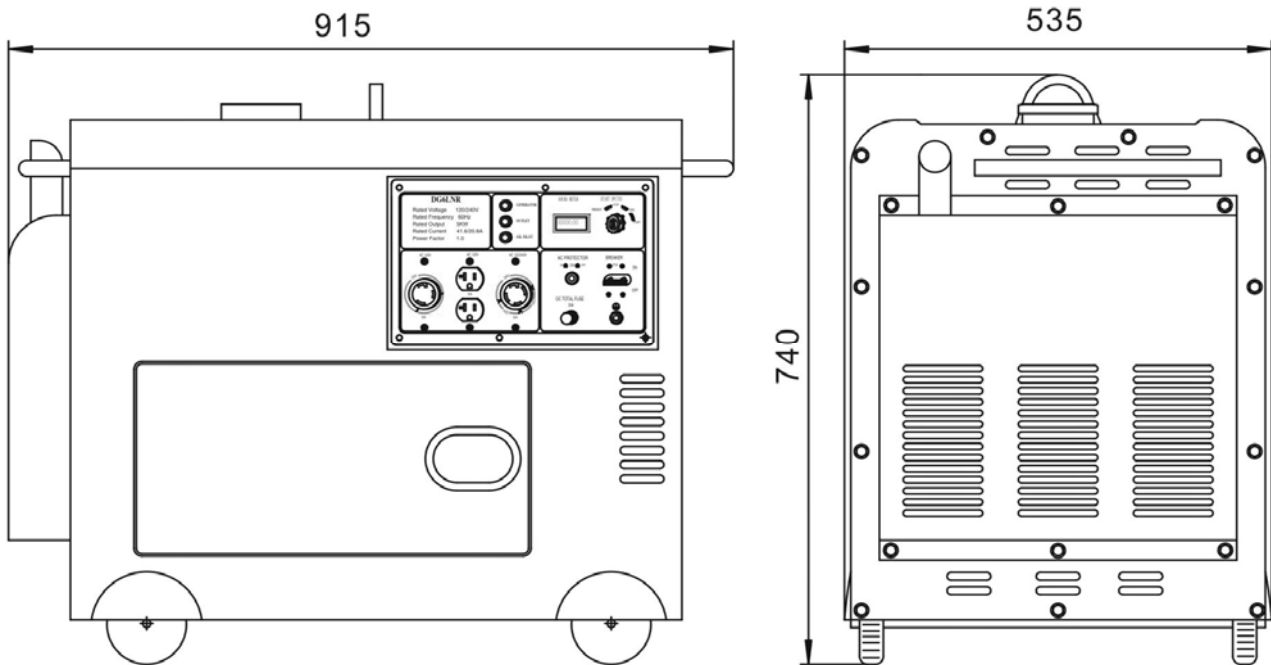

1-4 Electric wiring diagrams

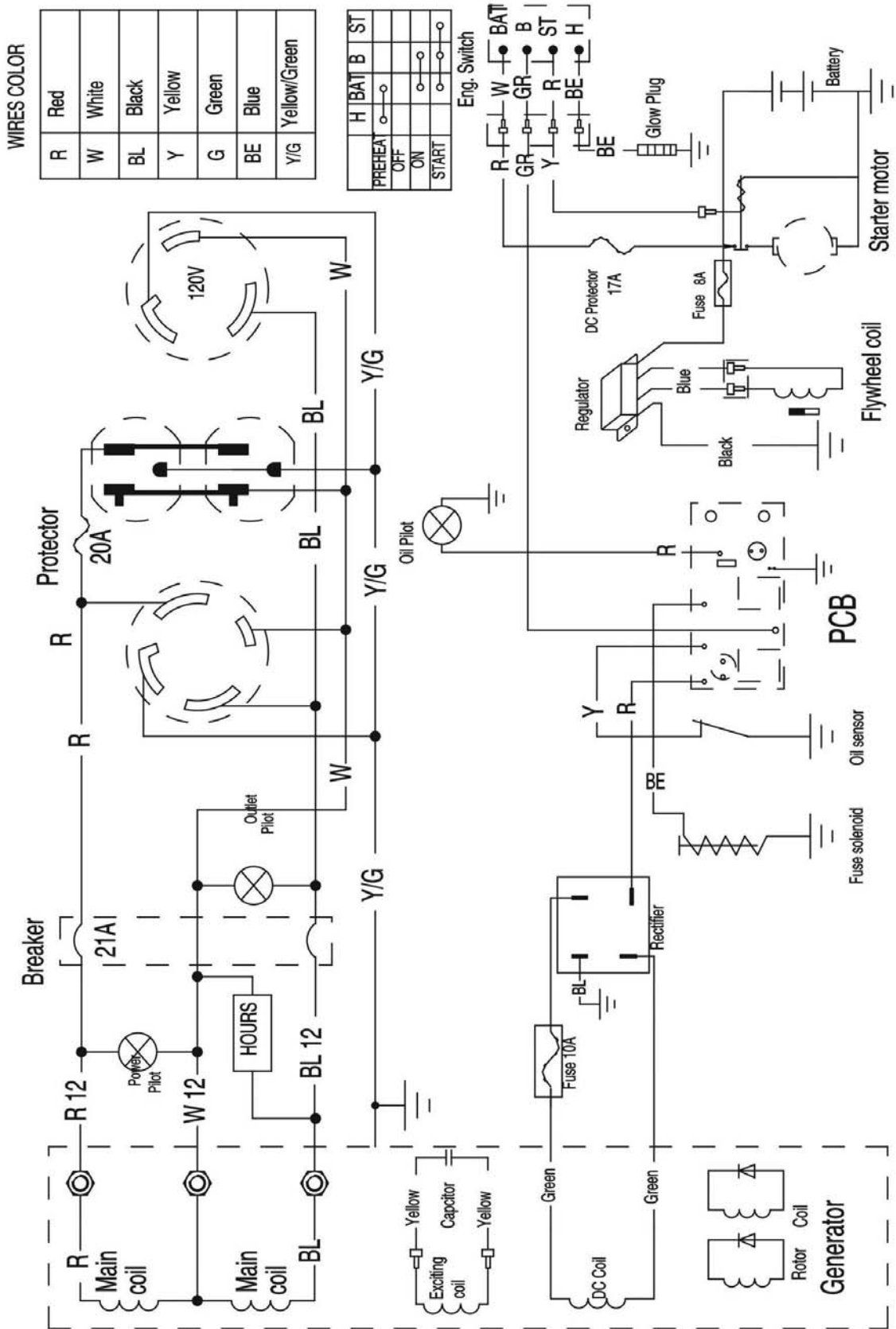

## CHAPTER 2 OPERATING THE DIESEL GENERATOR

### 2-1 Main points of safety during operation of the generator set.

In order to operate the generator set safely, please follow all the instructions provided in this manual carefully. Doing so otherwise may lead to accidents and or equipment damage.

#### 2-1.1 Fire prevention

The proper fuel for the diesel generator set is light diesel fuel. Do not use gasoline, kerosene and or other fuels other than light diesel fuel. Keep all flammable fuels away from the generator as the generator may spark and ignite these gases. In order to prevent fires from occurring and to provide enough ventilation for people and the machine, keep the diesel generator at least 1.5 meters away from buildings and or other equipment. Always operate your diesel generator on a level site. If the generator is operated on an incline, the lubricating system within the engine will not perform well and may lead to failure of the engine.

#### 2-1.2 Prevention from inhaling exhaust gases

Never inhale exhaust gases emitted by the engine. The exhaust gases contain toxic carbon monoxide. Never operate your generator in places with poor ventilation. In order to operate this machinery indoors, a suitable ventilation system for the building is required to draw the poisonous exhaust gases out.

#### 2-1.3 Prevention from accidental burns

Never touch the muffler and its cover when the diesel engine is running. Never touch the muffler and cover after the diesel engine has been used, as the muffler remains hot for a good period of time.

#### 2-1.4 Electric shock and short circuits

Never touch the generator if the generator is wet. Also never touch the generator if your hand is wet. Never operate your generator if the weather conditions call for any type of precipitation such as rain, snow, or fog. To prevent electrical shocks, the generator should be grounded. Use a lead to connect the grounding end of the generator to the grounding surface of choice. Please refer to Fig. 2-1 and Fig. 2-2 before beginning to use the generator.

Fig 2-1

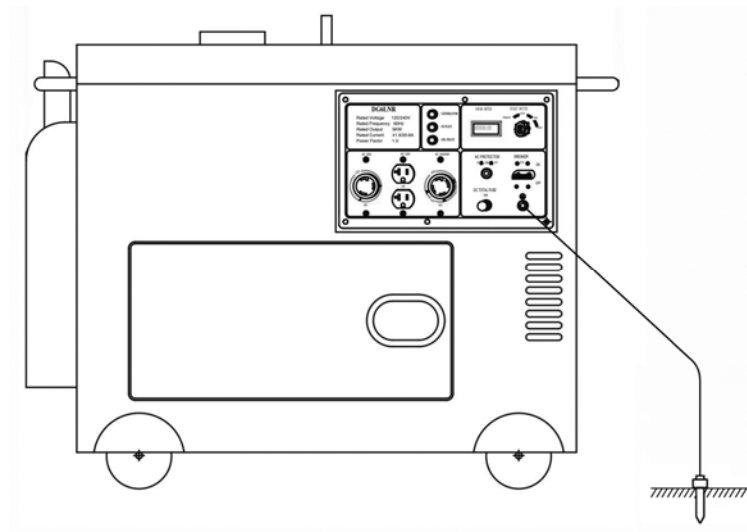

Note: When connecting devices to the generator, make sure all other devices are rated lower than The generators output. Any generator socket should not be overloaded over its regulated limit

### 2-1.5 Other safety points

Before operating this generator, all operators should have a good knowledge of how to break the circuit if any accidents occur. Also, all operators should be familiar with all the switches and functions of the generator before using this machine. While operating the generator, wear safe shoes and suitable clothes during operation. Always keep children and animals away from the generator.

### 2-1.6 Battery

The electrolytic liquid of the battery also known as battery acid contains sulfuric acid. In order to protect your eyes, skin, and clothing, wear protective gear when working with the battery. If you come in contact with the electrolytic liquid, wash it immediately with clean water. Also, if the electrolytic liquid comes in contact with your eyes, see a doctor immediately.



## 2-2 Preparation before operation

### 2-2.1 Fuel choices and fuel treatment

#### Fuel tank

Use only light diesel fuel. The fuel should be filtered clean. Never let dust and water mix with fuel in the fuel tank. Otherwise it will clog the fuel lines and oil nozzles. It may also damage your pressure pump.

Note: It is dangerous to overfill the fuel tank. Never exceed the red piston in the filter.

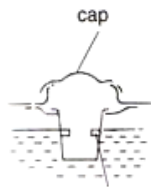

#### Air filter element

Do not wash the air filter. The element is made of dry material, which does not permit washing. When the output of the diesel engine is bad or the color of the exhaust gas is abnormal, replace the air filter element. Never start the diesel engine without the air filter.

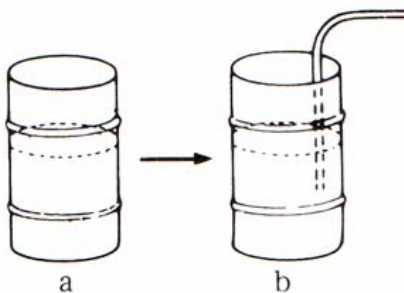

- a. After purchasing fuel, put it into a drum and let it sit for 3-4 days.
- b. 3-4 days later, insert half of the fuel sucker into the drum, (water and impurities stay in the lower portion of the drum)

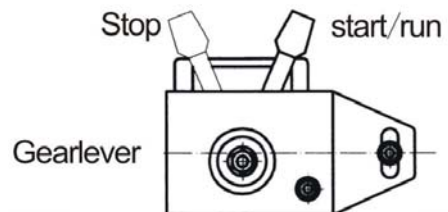

Note:  
Never smoke near the opening of the fuel tank. Do not let sparks get near the fuel or fuel tank and do not overfill tank. After filling, tighten the fuel cap.

2-2.2 Filling engine oil

Remove the dipstick from the engine  
 Make sure the generator is on level ground, and fill the engine with 15W40 engine oil. Put the dipstick back into the hole to check the engine oil level.

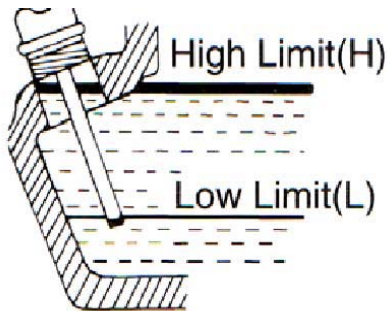

Model	186FA
Capacit	
Litre	1.65
(fl oz)	(55.79)

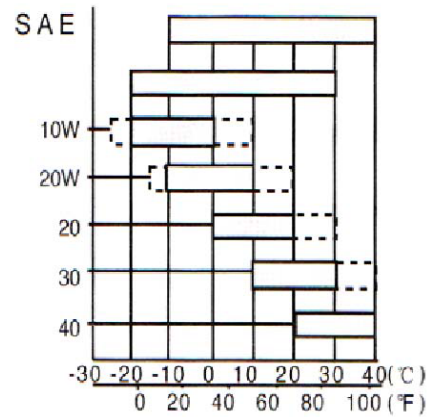

Ambient temperature

recommended values

Classification of maintenance for A.P.I. diesel engine

The lubricating oil must be CC or CD grade.

Engine oil is the most important factor in determining the life of your generator engine. If you use poor engine oil or if you don't change the oil regularly, the piston and cylinder will wear easily or seize up. Also, the life of the other parts in your engine such as bearings, and other rotating parts will shorten considerably.

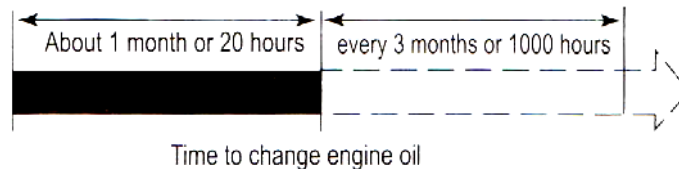

Time to change engine oil

Although there is an alarm system to check for low oil pressure, it is always a good idea to check the amount of oil inside the engine. If the oil level is low, fill it before starting the engine. A good time to drain the oil from the engine is when the diesel engine is still hot. If the engine is fully cooled, it is more difficult to drain all the oil out or some impurities will remain in the engine.

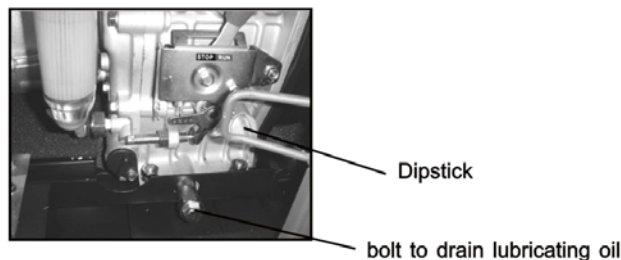

Warning: Don't fill engine oil when diesel is operating

2-2.3 Checking the air filter

(1) Loosen the butterfly nut, take the cover of the air filter off and take the air filter element out.

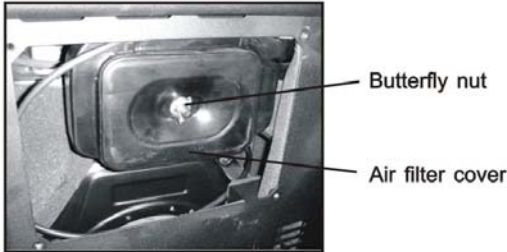

Do not use detergent to wash the air filter element. When the performance of the engine decreases or when the color of the exhaust gases is bad, exchange the filter element. Never start the engine without the air filter as foreign objects may enter the intake and damage the engine.

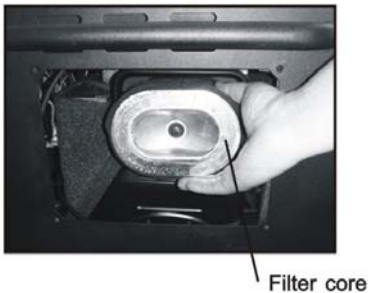

(2) After replacing the air filter element, replace the cover and tighten the butterfly nut firmly.



2-2.4 Checking the generator

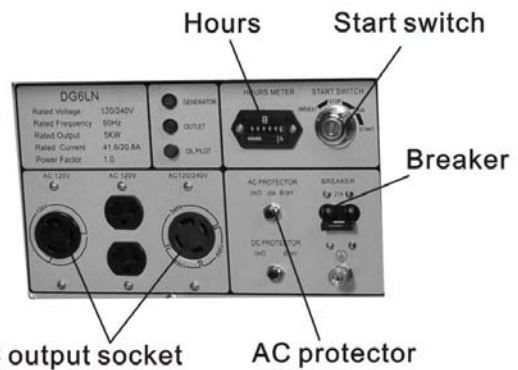

**(Note: Only certain generator sets have an electric fan incorporated on them.)**

Before starting the generator, make sure the breaker is in the “Off” position. Starting the generator with the breaker in the “On” position is very dangerous.

The generator should be grounded in order to prevent electric shock.

Use dry compressed air (with pressure about 1.96 x 10<sup>5</sup> Pa) to blow the dust out in the electric control cabinet and at the surface of the generator. Check to see how clean the surface of the sliding ring is. Also, check to see whether the connecting wire is correct and the connected place is firm.

2-2.5 The fuel and oil in a new engine is drained before sold

Before you start the engine, please fill the fuel tank and engine oil first. Then, check to see if there are air bubbles in the engine. If there are, follow these procedures. Loosen the connecting nut between the oil injection pump and oil pipe. Bleed the air from the system until there are no more bubbles. Then replace the connecting nut and tighten it.

## 2-3 Checking the operation of the diesel engine

### 2-3.1 Low-pressure alarm system.

ETQ diesel engines have a low-pressure sensor system where if the oil pressure drops too low, the sensor will shut the engine off. The purpose of having this system is to ensure that the engine does not seize up. If there is not enough oil in the engine, the temperature of the oil will be raised too high. On the contrary, if there is too much oil in the engine, the engine oil can slow the engine down considerably.

### 2-3.2 How to open the case door/cover

(1) Open the case door: turn the handle counterclockwise and open the door. Do these checks daily.



(2) Loosen the outer cover bolt of the air filter and outer cover of the oil nozzle, and then check the air filter.

(3) Check the outer cover of the oil nozzle.

Loosen the butterfly nut and open the outer cover.

### 2-3.3 Engine break in

When you purchase a brand new engine, the engine must be properly broken in. The break in period is about 20 hours.

(1) Avoid overloading the engine when brand new.

(2) Change the engine oil according to specifications. An oil change for a brand new engine is about 20 hours or every month, an older engine, the oil change is about 100 hours or three months.

## 2-4 Starting the generator set

### 2-4.1 Starting.

Start the engine in accordance with procedures below:

(1) Put the fuel switch in the "On" position.

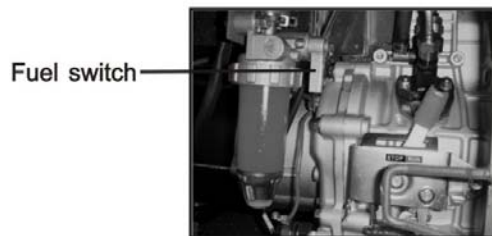

(2) Turn the handle of the engine to the "RUN" position.

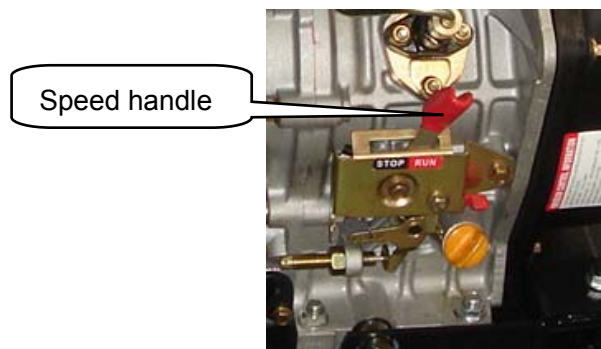

(3) Insert key into ignition and put it in the "OFF" position.

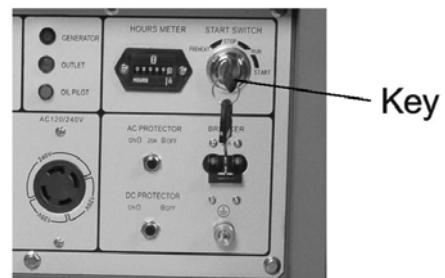

(4) In cold climate, it is difficult to start the engine. To remedy this, Turn the key counterclockwise to

the "PREHEAT" position,pre-heat the diesel engine for ten second,then starting the engine.

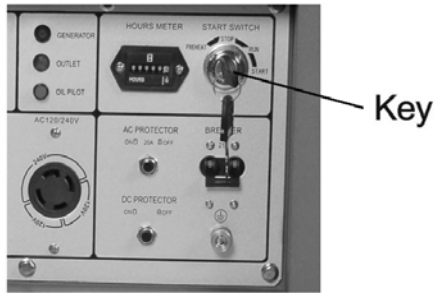

(6) After the diesel engine is started, remove your hand from the switch handle; the switch will automatically reset itself to the "ON" position.

(7) If the engine is not starting after 10 seconds of cranking, wait about 15 seconds before trying it again. If you crank to long, the voltage of the battery will drop. This can lead to improper ignition. When the diesel engine is operating, let the ignition retain on the "ON" position

(5) Turn the key clockwise to the "START" position.

**Note:**

If you crank the starter to long, the battery may be drained too much to provide enough energy for proper engine ignition. Also, when the diesel engine is operating, let the key retain in the "ON" position.



## 2-4.2 Battery

Important Notice: **ALL OF OUR UNITS DO NOT COME WITH A BATTERY FOR SHIPPING SAFETY PURPOSES.** In order to get your generator started for the first time;the battery must be purchased at a local hardware or automotive supply store. Please verify the dimensions of the generator battery tray with the size of battery to be purchased. Also,all diesel generators need to have a battery with a minimum of 32~38 amp hours. If you purchase a dry battery and fill it with acid,please verify the acid level of the battery once a month.

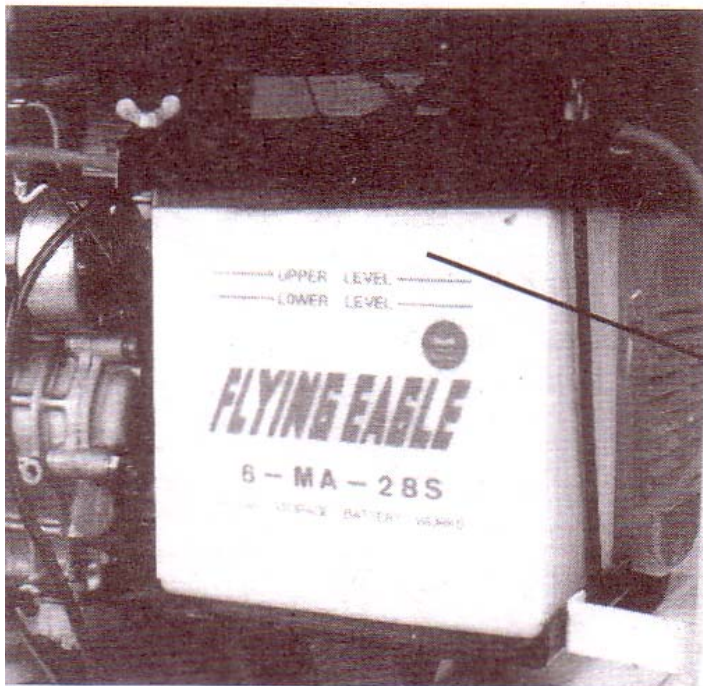

high limit of  
liquid level

### FOR DRY BATTERIES

If the level in the battery is too high, the liquid may flow out and end up on surrounding parts resulting in corrosion of these parts.

Note: Avoid too much or too little of battery acid. Check and fill it once a month if necessary.

## 2-5 Proper operation of the generator set

### 2-5.1 Operating the diesel engine

- (1) Preheat the diesel engine for 3 minutes under no load conditions.
- (2) First check the height of the lubricating oil level, if it is low, refill it. Our diesel engines are equipped with an alarm system that will notify you if the oil pressure is too low. The alarm system will shut down the engine if the oil pressure is too low. Warning: Don't check and fill engine oil when diesel is operating
- (3) Do not adjust the speed limit regulation bolt or the fuel adjustment bolt. These bolts have been set by the factory already, changing them will affect the properties of the engine performance.

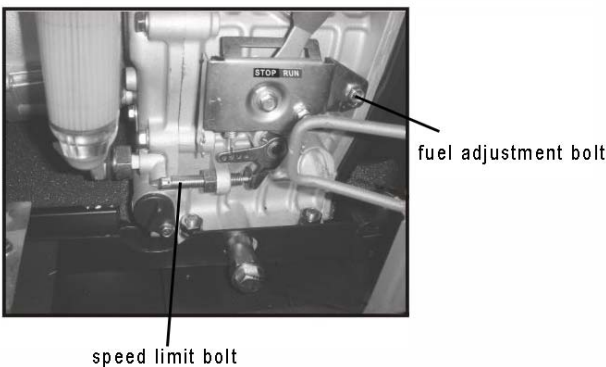

### 2-5.2 Checks during engine operation

- (1) Check to see if there are abnormal noises.
- (2) Check to see if the performance is good or bad.
- (3) Check the color of the exhaust gases (whether it is too black or too white). If any of these conditions exist, stop the engine and find the

cause of the problem. If no problems are found, please contact your local dealer or our nearest company branch.

## 2-6 Loading

### 2-6.1 Load conditions

Exert loads in accordance with the specified parameters.

### 2-6.2 Output of electricity

- (1) When connecting devices to the generator, make sure to connect these devices in order. Connect the large loads onto the generator first. If everything is functional, smaller loads can then be added. If the generator shuts off, it may be because the load being drawn by all the various devices are too high. In this event, decrease the number of small devices until everything is functional. The total drawn power should not exceed the maximum output power of the generator. Please see Table 2-1 for technical specifications of what the generator can output. In order to reset the generator after overdrawn power, let it sit for several minutes.
- (2) During operation, the generator should be in a place that has very good ventilation. Never cover the engine to solve a ventilation problem, as this will damage your equipment.

Table 2-1

Note: Do not start more than two devices simultaneously. Each device should be started one by one to prevent overloading the generator.

The generator should be running at 3600 revolutions per minute in order to achieve the (60Hz) frequency. The speed of the engine can be adjusted from the speed governor.

2-6.3 Charging the battery

- (1) For the electric starter on the generator , the 12V battery is automatically charged through the regulator on the side of the engine when it is running.
- (2) If the generator is not used for long periods of time, the battery should be disconnected to avoid energy loss from the battery.
- (3) Do not connect the negative and positive terminals of the battery together at any time. Doing so will damage the battery and cause serious injuries.
- (4) Do not reverse the polarities when attaching the battery cables to the battery. Doing so will damage both the battery and the electric starter.
- (5) When charging the battery, the battery produces flammable gases. Do not smoke, let flames, and sparks get near the battery while it is charging as this may cause a fire. To avoid sparking while connecting the cables to the battery, first, connect the cables to the battery then to the motor. To disconnect battery cables, first disconnect the motor end of the cable.

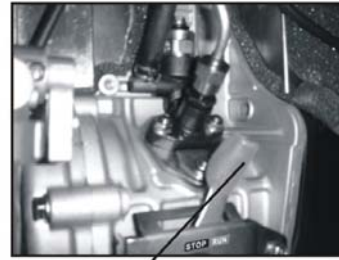

Speed handle

Note:

- 1. If the speed handle is in the “Stop” position and the engine is still running, turn the fuel switch to the “OFF” position or loosen the high pressure oil pipe nut. The engine could be stopped more than one-way other than the speed handle way.
- 2. If you cannot stop the engine with a load on it, then remove the load first than stop the engine.

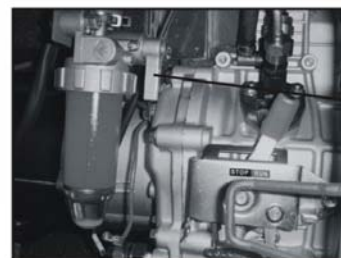

Fuel switch

2-7 Stopping the generator

- (1) Take the electrical load off the generator.
- (2) Put the speed handle in the “RUN” position and let the engine run for 3 minutes after unloading. Do not stop the diesel engine immediately let it warm down. Stopping the diesel engine suddenly may raise the temperature of the engine abnormally and lock the nozzle and damage the diesel engine.



Loose the nut(nut of high pressure oil pipe)

- (3) Press down on the brake handle.



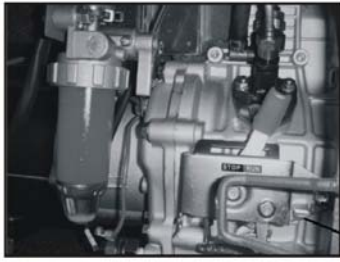

Brake handle

- (4) Turn the key to the “OFF” position.
- (5) Put the fuel handle to the “OFF” position.

## CHAPTER 3 MAINTENANCE

### 3-1 Maintenance schedules

Keeping your generator well maintained will prolong the life of your generator. Everything needs to be checked including the diesel engine, generator, control cabinet, and frame. For overhauling procedures, please refer to the instruction manual of the relative subassembly. If you need these manuals, please call our company and we will send you one.

Before starting the maintenance, make sure the diesel engine is off.

Please refer to the Table 3-1 for the proper maintenance schedule.

**Table 3-1. Maintenance schedule for diesel generator set**

Interval of maintenance Item	Everyday	1 <sup>st</sup> month or after 20 hours	3 <sup>rd</sup> month or 100 hours	6 <sup>th</sup> month or 500 hours	Every year or 1000 hours
Check and fill enough fuel	○				
Discharge fuel		○			
Check and fill enough engine oil	○				
Check whether it leaks oil	○				
Check and screw each fastened part	○			● (Screw the bolt of cylinder head firmly)	
Exchange engine oil		○ (1 <sup>st</sup> time)	○ (2 <sup>nd</sup> time late)		
Clean filter of engine oil				○ (Exchange)	
Exchange air filter element	(If operated at dusty region, the period of maintenance should be shorten)			○ (Exchange)	
Clean filter of fuel				○	● (Exchange)
Check high pressure oil pump				●	
Check nozzle				●	
Check fuel pipe				● (If necessary exchange it)	
Adjust the gaps of air intake and air exhausted gate		● (1 <sup>st</sup> time)		●	
Grind air intake and air exhausted gate					●
Exchange piston ring					●
Check electrolytic solution of accumulator	(each month) ○				
Check insulation resistance	The time of stop is over 10 days. ○				

Note: “●” mark indicates that it needs special wrench, please contact with dealer of ETQ.

3-1.1 Changing the engine oil (every 100 hours)

Take the oil cover off. Remove the oil drain plug when the diesel engine is still hot. Be careful of hot oil and hot engine as you may get burned. The bolt is located at the bottom of the cylinder. After draining the oil, put the bolt back and tighten it. Then fill with the proper engine oil to the proper level.

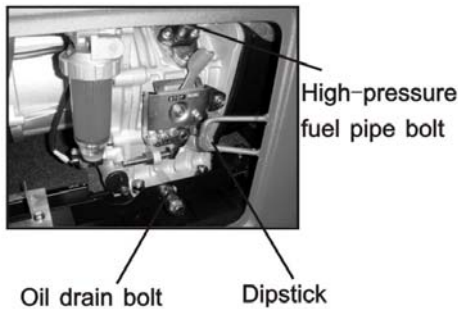

3-1.2 Air filter maintenance schedule

- (1) Clean air-filter every 6 months or 500 hours of operation.
- (2) If necessary, exchange it.
- (3) Do not use detergent to clean air filter element.

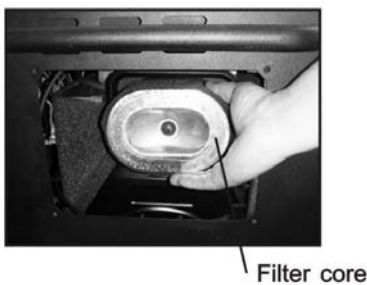

**Note:**  
 Never start the engine without the air filter. This can cause serious damage to the engine if foreign objects enter the intake system. Always change the air filter on time.

3-1.3 Fuel filter maintenance

- (1) The fuel filter should be cleaned often to keep the engine running at maximum performance.
- (2) The recommended time period for cleaning the fuel filter is 6 months or 500 hours of operation.
  - a. To do this, first drain the fuel from the fuel tank.
  - b. Loosen the small screws on the fuel switch and remove the fuel filter from the port. Use diesel fuel to clean the fuel filter. Also, remove the fuel injector and clean the carbon deposit around it. The recommended time period for this is 3 months or 100 hours.

3-1.4 Cylinder head bolt tensions

The cylinder head bolts should be tightened to specifications please refer to the diesel engine manual for specifications and the special tools required to do this.

3-1.5 Battery check

Make sure the battery acid is full. The engine uses a 12V battery. Due to numerous starting cycles, the battery acid may be used up. Also, before filling, verify that the battery is not damaged in any way. Add distilled water to the battery when filling. Perform checks on the battery once a month.

### 3-2 Storing for long periods of time

If your generator needs to be stored for long periods of time, the following preparations should be made.

- (1) Start the diesel engine for 3 minutes then stop it.
- (2) When the engine is still hot, change the engine oil with new engine oil of the proper grade.
- (3) For manual starting generator, press the decompression handle down and pull the recoil handle 2 or 3 times. This pushes the intake out. (Do not start the engine)
- (4) For electric started generator, press the decompression handle down and crank the engine for 2-3 seconds. To do this, put the starter switch in the "Start" position. (Do not start the diesel engine)
- (5) Clean the engine and store it in a dry place.

## CHAPTER 4 TROUBLESHOOTING

### 4-1 Troubleshooting procedures

Causes of malfunction		Remedy
Diesel cannot be started.	Not enough fuel.	Add enough fuel.
	The switch of fuel is not at "OPEN" position.	Turn the switch of fuel to "OPEN" position.
	High-pressure pump and nozzle do not inject fuel or the injected amount is less.	Disassemble the nozzle and adjust it at test table.
	Speed control lever is not at "RUN" position.	Turn speed control lever to "RUN" position.
	Check level of lubrication oil.	The standard oil amount of lubricating oil should be between high graduation "H" and low graduation "L".
	It is not quick and powerful to pull reactive starter.	Start diesel engine in accordance with the requirements of "start operation procedures".
	Nozzle exists dirt.	Clean the nozzle.
	Accumulator has not electricity.	Charge the accumulator exchange it.
Generator cannot electricity.	Master switch is not be switched on.	Turn master switch handle to "ON" position.
	The contact of socket is bad.	Adjust the contact feet of socket.
	The rated revolution of engine cannot be reached.	Make it reach to the rated revolution in accordance with the requirements.
	Capacitance is damaged	Exchange it.
	Generator is overloaded	Try connecting fewer electrical loads to the generator.

If you are still having trouble, please contact with your nearest dealer or with our company directly if necessary.

### 4-2 Questions and doubts

If you do not understand anything or have any questions, please feel free to contact your local dealer or with our company directly. Below is a list of some information you should have ready before contacting your local dealer or us.

- (1) Model of diesel engine generator and engine model number.
- (2) State of residency.
- (3) Number of hours of operating equipment along with the problem that occurred.
- (4) A detailed condition and time when the problem occurred, in other words, climate and atmosphere.

## CHAPTER 5 GENERATOR PARTS DIAGRAMS AND LISTINGS

**Figure 5-1. Overall view of engine generator assembly**

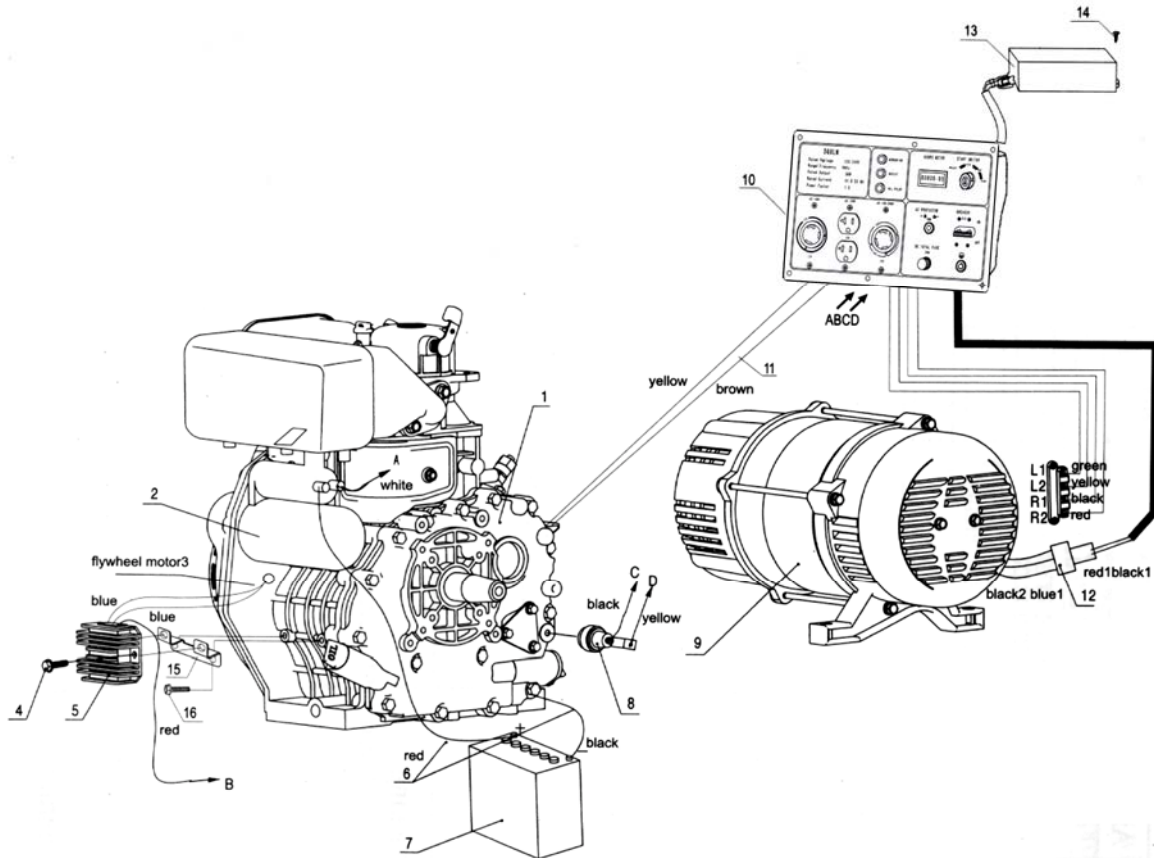

Table 5-1. Please refer to figure 5-1 for illustration

Number	Part Description	Quantity	Part Number
1	Diesel engine	1	ETQDG6LN01
2	Starter Motor	1	ETQDG6LN02
3	Flywheel generator	1	ETQDG6LN03
4	Bolt	2	ETQDG6LN04
5	Voltage Regulator	1	ETQDG6LN05
6	Battery Cable (red /black)	1	ETQDG6LN06
7	Battery	1	ETQDG6LN07
8	Oil level sensor	1	ETQDG6LN08
9	Alternator	1	ETQDG6LN09
10	Output panel assembly	1	ETQDG6LN10
11	Throttle cable	2	ETQDG6LN11
12	Connector assembly	1	ETQDG6LN12
13	Capacitor	1	ETQDG6LN13
14	Bolt	2	ETQDG6LN14
15	Voltage Regulator Bracket	1	ETQDG6LN15
16	Bolt	2	ETQDG6LN16

**Figure 5-2. Exploded view of frame assembly**

Table 5-2. Please refer to figure 5-2.

Number	Part Description	Quantity	Part Number
1	Muffler cover plate	1	ETQDG6LN17
2	Muffler elbow	1	ETQDG6LN18
3	Left outer cover	1	ETQDG6LN19
4	Rear door	1	ETQDG6LN20
5	Fuel gauge	1	ETQDG6LN21
6	Fuel tank sleeve	1	ETQDG6LN22
7	Main cover	1	ETQDG6LN23
8	Door knob	1	ETQDG6LN24
9	Air cleaner plate	1	ETQDG6LN25
10	Air deflector cover	1	ETQDG6LN26
11	Right outer cover	1	ETQDG6LN27
12	Output panel assembly	1	ETQDG6LN28
13	Air cleaner cover	1	ETQDG6LN29
14	Lower Chassis	1	ETQDG6LN30
15	Engine tray mounts	4	ETQDG6LN31
16	Engine / Generator tray	1	ETQDG6LN32
17	Wheels	4	ETQDG6LN33
18	Battery	1	ETQDG6LN34
19	Battery tie down	1	ETQDG6LN35
20	Long cover plate	1	ETQDG6LN36

**Figure 5-3. Electric panel parts drawing**

Table 5-3. Please refer to Figure 5-3

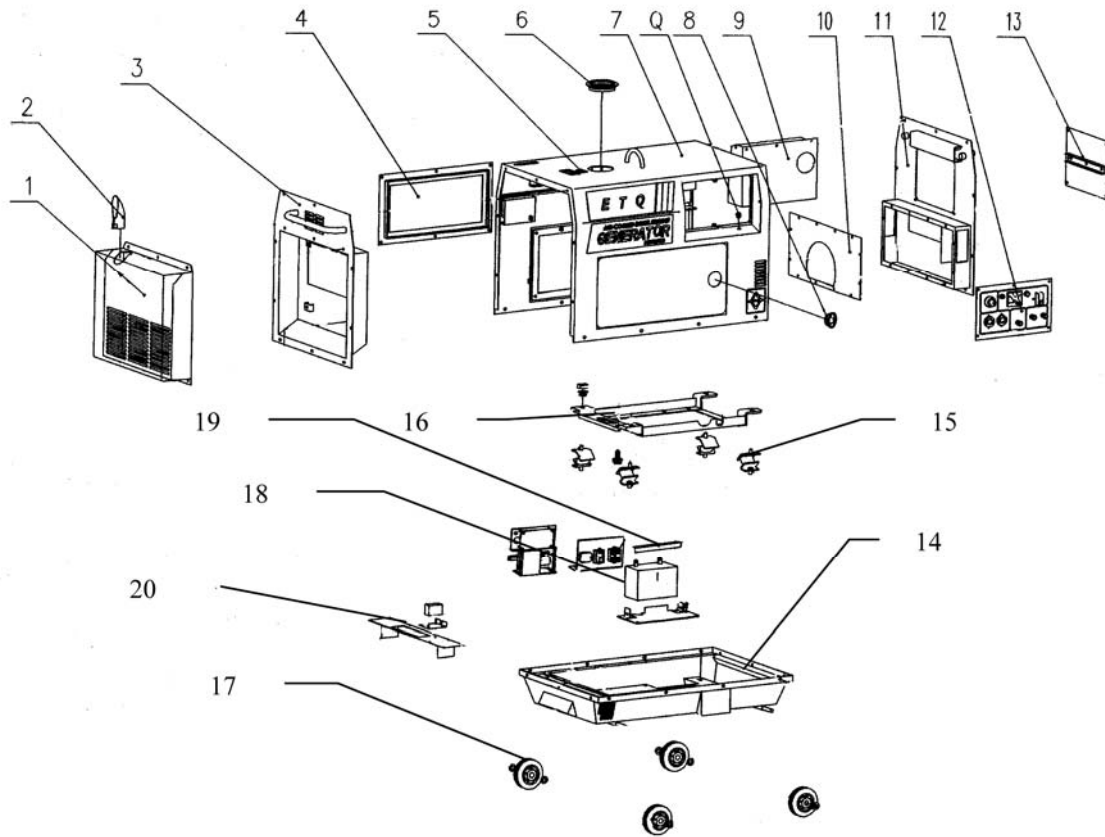
Number	Part Description	Quantity	Part Number
1	Panel	1	ETQDG6LN37
2	Flanged bolt M6x12	6	ETQDG6LN38
3	Wiring board	1	ETQDG6LN39
4	Bolt M4x12	1	ETQDG6LN40
5	Oli alert lamp	1	ETQDG6LN41
6	Outlet pilot lamp	1	ETQDG6LN42
7	Generator pilot lamp	1	ETQDG6LN43
8	Hour meter	1	ETQDG6LN44
9	Bolt M5x12	2	ETQDG6LN45
10	Nut M5	2	ETQDG6LN46
11	Key	1	ETQDG6LN47
12	Starter switch	1	ETQDG6LN48
13	Oval head Bolt M3x8	4	ETQDG6LN49
14	Circuit Breaker	1	ETQDG6LN50
15	Large nut	1	ETQDG6LN51
16	AC protector	1	ETQDG6LN52
17	Grounded bolt	1	ETQDG6LN53
18	DC Fuse	1	ETQDG6LN54
19	4 prong socket	1	ETQDG6LN55
20	Washer $\phi$ 4.5	6	ETQDG6LN56
21	Spring washer $\phi$ 4.2	6	ETQDG6LN57
22	Nut M4	6	ETQDG6LN58
23	Bolt M4x12	6	ETQDG6LN59
24	Double socket	1	ETQDG6LN60
25	3 prong socket	1	ETQDG6LN61
26	Wiring harness	1	ETQDG6LN62



Figure 5-4. Generator head assembly

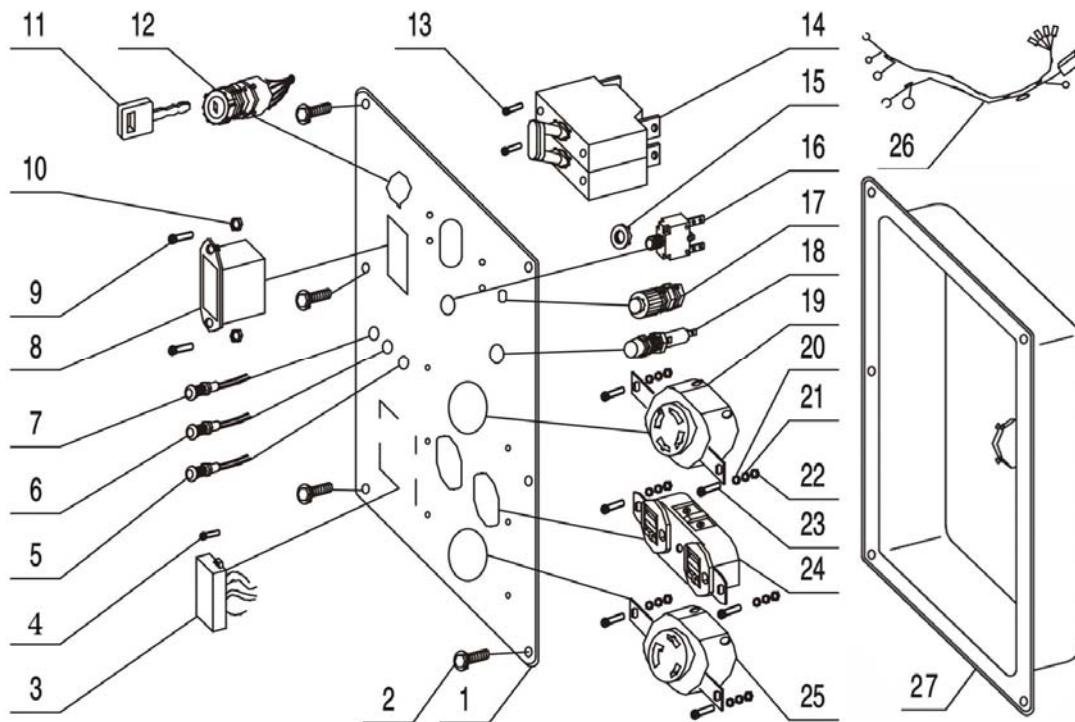
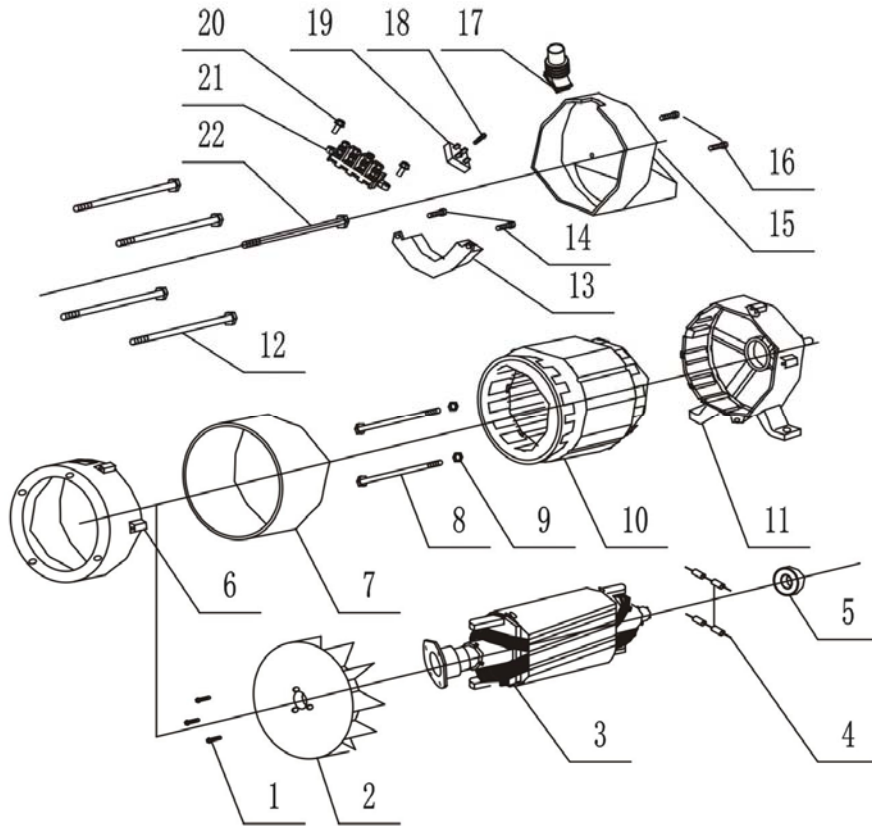

Table 5-4. Please refer to figure 5-4

Number	Part Description	Quantity	Part Number
1	Oval head Bolt M6x12	3	ETQDG6LN63
2	Fan Blade	1	ETQDG6LN64
3	Rotor	1	ETQDG6LN65
4	Diode	4	ETQDG6LN66
5	Bearing	1	ETQDG6LN67
6	Front end cover	1	ETQDG6LN68
7	Motor cover	1	ETQDG6LN69
8	Hex bolt M5x220	2	ETQDG6LN70
9	Nut M5	2	ETQDG6LN71
10	Stator	1	ETQDG6LN72
11	Alternator cover	1	ETQDG6LN73
12	Hex bolt M6x185	4	ETQDG6LN74
13	Capacitor	1	ETQDG6LN75
14	Hex bolt M5x12	2	ETQDG6LN76
15	Dust Cover	1	ETQDG6LN77
16	Oval head Bolt M5x10	2	ETQDG6LN78
17	Outlet trap	1	ETQDG6LN79
18	Oval head Bolt M5x12	1	ETQDG6LN80
19	Rectifier bridge	1	ETQDG6LN81
20	Hex bolt M5x16	2	ETQDG6LN82
21	Wiring seat	1	ETQDG6LN83
22	Center bolt	1	ETQDG6LN84

Figure 5-5. Fuel system components

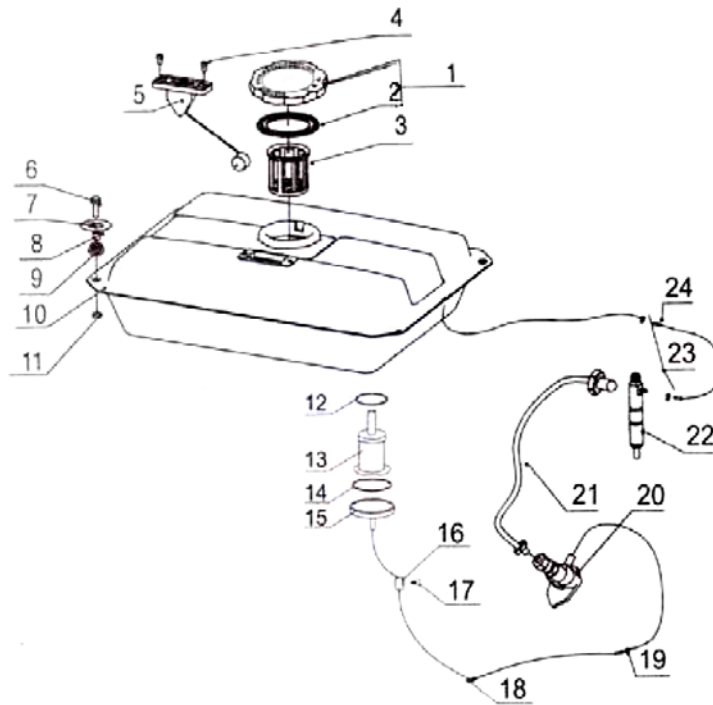

Table 5-5. Please refer to figure 5-5.

Number	Part Description	Quantity	Part Number
1	Fuel Cap	1	ETQDG6LN85
2	Seal	1	ETQDG6LN86
3	Filtering cup	1	ETQDG6LN87
4	M5 x 10 screw	2	ETQDG6LN88
5	Fuel lever indicator	1	ETQDG6LN89
6	M6 x 25 Bolt	4	ETQDG6LN90
7	Large flat washer 6	4	ETQDG6LN91
8	Fuel tank lining	4	ETQDG6LN92
9	Shock absorbing gasket	4	ETQDG6LN93
10	Fuel tank	1	ETQDG6LN94
11	M6 Nut	4	ETQDG6LN95
12	O ring seal	1	ETQDG6LN96
13	Fuel tank filter	1	ETQDG6LN97
14	O ring gasket	1	ETQDG6LN98
15	Fuel filter cover	1	ETQDG6LN99
16	Cover	1	ETQDG6LN100
17	Wing nut	1	ETQDG6LN101
18	Fuel line	2	ETQDG6LN102
19	Fuel inlet pipe	1	ETQDG6LN103
20	High pressure fuel pump	1	ETQDG6LN104
21	High pressure fuel pipe	1	ETQDG6LN105
22	Fuel injector	1	ETQDG6LN106
23	Overfill tube	2	ETQDG6LN107
24	Fuel overfill pipe	1	ETQDG6LN108



### LIMITED WARRANTY

Eastern Tools & Equipment, Inc. will repair or replace, free of charge, any part or parts of the generator that are defective in material or workmanship or both. Transportation charges on parts submitted for repair or replacement under this Warranty must be borne by purchaser. This warranty is effective for the time period and subject to the conditions provided for in this policy. For warranty service, find the nearest Authorized Service Dealer by contacting the place of purchase or Eastern Tools & Equipment, Inc. THERE IS NO OTHER EXPRESSED WARRANTY. IMPLIED WARRANTIES, INCLUDING THOSE OF MERCHANTABILITY AND FITNESS FOR A PARTICULAR PURPOSE, ARE LIMITED TO ONE YEAR FROM PURCHASE, OR TO THE EXTENT PERMITTED BY LAW ANY AND ALL IMPLIED WARRANTIES ARE EXCLUDED. LIABILITY FOR CONSEQUENTIAL DAMAGES UNDER ANY AND ALL WARRANTIES ARE EXCLUDED TO THE EXTENT EXCLUSION IS PERMITTED BY LAW. Some states do not allow limitations on how long an implied warranty lasts, and some states do not allow the exclusion or limitation of incidental or consequential damages, so the above limitation and exclusion may not apply to you. This warranty gives you specific legal rights and you may also have other rights, which vary from state to state.

**Eastern Tools & Equipment, Inc.**

#### WARRANTY PERIOD\*\*\*

ENGINES	WITHIN U.S.A AND CANADA		OUTSIDE U.S.A. AND CANADA	
	CONSUMER USE	COMMERCIAL USE	CONSUMER USE	COMMERCIAL USE
DIESEL GENERATOR	1 year Or 1000 hours	90 days	1 year Or 1000 hours	90 days

\*The warranty period begins on the date of purchase by the first retail consumer or commercial end user, and continues for the period of time stated in the table above. "Consumer use" means personal residential household use by a retail consumer. "Commercial use" means all other uses, including the commercial, income producing or rental purpose. Once the engine has experienced commercial use, it shall thereafter be considered as a commercial use engine for purpose of this warranty. **Engines use in competitive racing or commercial or rental tracks are not warranted.**

\*\*\*A two-year or 1,500 hours warranty applies to the emission control system on engines certified by EPA and CARB.

**IMPORTANT**  
**"WARRANTY REGISTRATIONS IS NECESSARY TO OBTAIN LIMITED WARRANTY ON EASTERN TOOLS & EQUIPMENT, INC., ENGINES. THE WARRANTY REGISTRATION CARD MUST BE RETURNED WITHIN 15 DAYS OF PURCHASE FOR LIMITED WARRANTY TO BE VALID"**

#### **About Your Product Warranty**

Eastern Tools & Equipment, Inc. welcomes warranty repair and apologizes to you for being inconvenienced. Any Authorized Service Dealer may perform warranty repairs. Most warranty repairs are handled routinely, but sometimes warranty service may be inappropriate. For example, warranty would not apply if an engine is damaged because of misuse, lack of routine maintenance, shipping, handling, warehousing and improper installation. Similarly, warranty is void if the serial number on the engine has been removed or if the engine has been altered or modified. If a customer differs with the decision of the Service Dealer, an investigation will be made to determine whether the warranty applies. Ask the Service Dealer to submit all supporting facts to his Distributor or the factory for review. If the distributor or the factory decides that the claim is justified, the customer will be fully reimbursed for those items that are defective. To avoid misunderstanding, which might occur between the customer and the dealer, listed below are some of the causes of engine failure that the warranty does not cover.

**Normal wear:**

Engines and generators, like all mechanical devices, need periodic parts service and replacement to perform well. Warranty will not cover repair when normal use has exhausted the life of a part of an engine.

**Improper maintenance:**

The life of an engine or your equipment depends upon the conditions under which it operates, and the care it receives. Some applications, such as tillers, pumps, and rotary movers, are very often used in dusty or dirty conditions, which can cause what appears to be premature wear. Such wear, when caused by dirt, dust, spark plug cleaning grit, or other abrasive material that has entered the engine because of improper maintenance is not covered by warranty.

**This warranty cover engine related defective material and/or workmanship only, and not replacement or refund of the equipment to which the engine may be mounted. Nor des the warranty extend to repairs required because of:**

- (1) PROBLEMS CAUSED BY PARTS THAT ARE NOT ORIGINAL EASTERN TOOLS & EQUIPMENT, INC., PARTS.
- (2) Equipment controls or installations that prevent starting, cause unsatisfactory engine performance, or shorten engine life. (Contact equipment manufacturer.)
- (3) Check clogged fuel pipes, high-pressure fuel pipe, or other damage, caused by using contaminated or stale fuel. (Use clean, fresh, diesel.)
- (4) Parts which are scored or broken because an engine was operated with insufficient or contaminated lubricating oil, or and incorrect grad of lubricating oil (check oil level daily or after every 8 hours of operation. Refill when necessary and change at recommended intervals.) Engine damage may occur if oil level is not properly maintained. Read Operating & Maintenance Instructions.
- (5) Repair or adjustment of associated parts or assemblies such as clutches, transmissions, remote controls, etc., which are not manufactured by Eastern Tools & Equipment, Inc.
- (6) Damage or wear to parts caused by dirt, which entered the engine because of improper air filter maintenance, re-assembly, or use of a non-original air filter element or cartridge. Read Operating & Maintenance Instructions.
- (7) Parts damaged by over-speeding, or overheating caused by grass, debris, or dirt, which plugs or clogs the cooling fins, or flywheel are, or damaged caused by operating the engine in a confined area without sufficient ventilation.
- (8) Engine or equipment parts broken by excessive vibration caused by a loose cutter blades unbalanced blades or loose or unbalanced impellers, improper attachment of equipment to engine crankshaft, over-speeding or other abuse in operation.
- (9) A bent or broken crankshaft, caused by striking a solid object with the cutter blade of a rotary lawn mower, or excessive v-belt tightness.



(10) Routine tune-up or adjustment of the engine.

(11) Engine or engine component failure, i.e., combustion chamber, valves, valve seats, valve guides, or burned starter motor winding, caused by the use of alternated fuels such as, liquefied petroleum, natural gas, altered diesel's etc.

**Warranty is available only through service dealers, which have been authorized by Eastern Tools & Equipment, Inc., contact place of purchase or Eastern Tools & Equipment, Inc. for Service Dealer near you.**

### **CALIFORNIA & US EPA EMISSION CONTROL WARRANTY STATEMENT**

The U.S. Environmental Protection Agency (EPA), the California Air Resources Board (CARB) and Eastern Tools & Equipment, Inc. are pleased to explain the Federal and California Emission Control System Warranty on your small non road engine. In California, new small off-road engines must be designed, built and equipped to meet the State's stringent and anti-smog standards. Eastern Tools & Equipment, Inc. must warrant the emission control system on your small off-road engine for the periods of time listed above provided there has been no abuse, neglect or improper maintenance of your small non road engine.

Your emission control system may include parts such as the fuel-injection system and catalytic converter. Also included may be hoses, belts, connectors and other emission-related assemblies.

Where a warrantable condition exists, Eastern Tools & Equipment, Inc. will repair your small non road engine at no cost to you including diagnosis, parts and labor.

### **OWNER'S WARRANTY RESPONSIBILITIES**

As the small non road engine owner, you are responsible for the performance of the required maintenance listed in your Owner's Manual. Eastern Tools & Equipment, Inc. recommends that you retain all receipts covering maintenance on your small non road engine, but Eastern Tools & Equipment, Inc. cannot deny warranty solely for the lack of receipts or for your failure to ensure the performance of all scheduled maintenance.

As the small non road engine owner, you should, however, be aware that Eastern Tools & Equipment, Inc. may deny you warranty coverage if your; small non road or part thereof has failed due to abuse, neglect, improper maintenance or unapproved modifications.

You are responsible for presenting your small non road engine to Eastern Tools & Equipment, Inc. distribution center as soon as a problem exists. The warranty repairs should be completed in a reasonable amount of time, not to exceed 30 days.

If you have any questions regarding your warranty rights and responsibilities or request warranty service you should contact either the place of purchase or Eastern Tools & Equipment, Inc., c/o Service Manager, Engine and Equipment Service Division.

### **IMPORTANT NOTE:**

This warranty statement explains your rights and obligations under Emission Control system Warranty (ECS Warranty),



which is provided to our by Eastern Tools & Equipment, Inc. pursuant to California law, Eastern Tools & Equipment, Inc. also provides to original purchasers of new Eastern Tools & Equipment, Inc. engines. Eastern Tools & Equipment, Inc. Limited Warranties for New engines & other Equipment associated with the engine (Eastern Tools & Equipment, Inc. Products Warranty), which is enclosed with all New Eastern Tools & Equipment, Inc. engines and products on a separate sheet. The ECS Warranty applies only to the emission control system of your new engine. To the extent that there is any conflict in terms between the ECS Warranty and the Eastern Tools & Equipment, Inc., Warranty, the ECS Warranty shall apply except in any circumstances in which the Eastern Tools & Equipment, Inc. Product Warranty may provide a longer warranty period. Both the ECS Warranty and the Eastern Tools & Equipment, Inc. product Warranty describe important right and obligations with respect to your new engine.

Eastern Tools & Equipment, Inc. at its location in Ontario, California can perform warranty service or any authorized service dealer near you. At the time of requesting warranty service, evidence must be presented of the date of sale to the original purchaser. The purchaser shall pay any charges for transporting the product to and from the place when the inspection and/or warranty preformed. The purchaser shall be responsible for any damage or loss incurred in connection with the transportation of any engine or any part(s) thereof submitted for inspection and/or warranty work.

If you have any questions regarding your warranty rights and responsibilities, you should contact Eastern Tools & Equipment, Inc.



### PRODUCT REGISTRATION CARD

For more efficient customer service, please fill out the information below and mail to Eastern Tools & Equipment, Inc. Product Warranty and Registration Division, 600 Industrial Parkway Norwalk, OH 44857

Model No. \_\_\_\_\_ Engine Serial No. \_\_\_\_\_ Purchase Date \_\_\_\_/\_\_\_\_/\_\_\_\_

**Purchased from:**

Retail Location  Private Consumer  Other \_\_\_\_\_

Name \_\_\_\_\_

Address \_\_\_\_\_

Telephone (\_\_\_\_)\_\_\_\_-\_\_\_\_\_ Purchase

Price \_\_\_\_\_

Purchased:  New  Used

**Consumer Information:**

Name \_\_\_\_\_ Telephone (\_\_\_\_) \_\_\_\_ - \_\_\_\_\_

Street Address \_\_\_\_\_ Suite or Apt No. \_\_\_\_\_

City \_\_\_\_\_ State \_\_\_\_\_ Zip Code \_\_\_\_\_

Province or County \_\_\_\_\_

Are you a:  Business  Residence

**Product Usage Information:**

How often will you use this product?

Everyday  Periodically  Emergency Use Only  Other

**What type of application will you use this product in?**

Heavy Commercial  Moderate Commercial  Light Commercial  Tradeshows

Heavy Residential  Moderate Residential  Light Residential  Camping/Backpacking

Other \_\_\_\_\_

**Important information:**

It is critical to your warranty that the original point of sales receipt be retained by current consumer, and in order to comply with Eastern Tools & Equipment Product Warranty statement you must return the registration card within 15 days of original purchase. Product warranty is valid from original date of purchase.



**LIST FOR COMMENTS FROM USERS**

Name of user		Date of Manufacture	
Address of user		Model Number	
Place of purchase		Occupation	
Packaging conditions			
Operating conditions			
Parts Conditions			
Malfunction problem			
Opinions or suggestions			

Note: Please mail the above card to: **Eastern Tools & Equipment, Inc.**  
**600 Industrial Parkway**  
**Norwalk, OH 44857**





**APPENDIX:**

(1) Attached list of tools, fittings, and subassemblies

Order No.	Name	Qty	Remarks
1	Air-cooled diesel generator set	1	
2	Kit	1	
3	Plastic cover	1	

(2) Attached technical documents

Order No.	Name	Qty	Remarks
1	Air cooled diesel generator manual	1	

EASTERN TOOLS & EQUIPMENT, INC.

TEL:1-909-390-8989

FAX:1-909-390-6068

For sales, call toll free 1-888-696-2345

WEB SITE.<http://easterntools.com>