



## OWNER'S MANUAL

# SWAYCONTROL



TEAMBPRO.COM

Designed and Engineered in the USA by Tuson RV Brakes, LLC

**MANUAL PART 033536**  
REV 1.0

The BMPRO product range represent a high-quality product that will provide years of service.



**DISCLAIMER** BMPRO accepts no liability for any loss or damage which may occur from the improper or unsafe use of its products. Warranty is only valid if the unit has not been modified or misused by the customer.



## POWERING YOUR ADVENTURES

With over 50 years' experience in power solutions combined with manufacturing and design facilities in Melbourne, Australia, we are the leading experts in RV power management.

Inspired by the great outdoors, we have created a range of rugged, smart and reliable products to power your adventures.

Our range of battery chargers, monitors and power management systems for caravans gives you peace of mind when you are on the road, so that you can relax in even the most far-flung destinations, knowing you have control over your power needs.

To learn more about the BM PRO range of products, please visit our website [teambmpro.com](https://teambmpro.com)



# ABOUT THE SWAYCONTROL

BMPRO SwayControl is a proactive electronic stability control that can automatically stabilise a caravan/trailer in the event of a sway. It automatically corrects caravan/trailer sway which can be caused by changing road conditions, driver error, lateral winds or a passing truck, keeping drivers safe on the road. The SwayControl is mounted on the underside of the caravan/trailer chassis, wires directly to the trailer braking system and continuously monitors the trailer to detect sway. If sway is detected the SwayControl automatically activates the caravan/trailer brakes to bring them and the vehicle under control.

SwayControl distinguishes between safe maneuvering and dangerous trailer sway and does not require driver intervention. With independent control of left and right-hand side trailer brakes, and continual closed loop feedback, the SwayControl quickly and effectively applies the necessary braking force to the side of the caravan/trailer where it is needed to correct trailer sway.

## WHAT'S INCLUDED

Included with this product are:

- ▣ **SwayControl**
- ▣ Status Light Module
- ▣ **SwayControl** Owner's Manual

SwayControl loom is available as an option – please contact BMPRO for pricing.

## COMPATIBLE BRAKE CONTROLLERS

The **SwayControl** may be used with various integrated and aftermarket brake controllers, including brake controllers from:

- ▣ Ford
- ▣ General Motors
- ▣ Hayes
- ▣ Nissan
- ▣ Redarc
- ▣ Tekonsha
- ▣ Toyota

Brake controllers from other companies not listed in this manual may also work with the SwayControl.

# CONTENTS

ABOUT THE SWAYCONTROL	4
WHAT'S INCLUDED	4
COMPATIBLE BRAKE CONTROLLERS	4
INSTALLATION INSTRUCTIONS	6
PERSONNEL	6
MOUNTING LOCATION CONSIDERATIONS	6
ORIENTATION	6
MOUNTING	7
WIRING INSTRUCTIONS	9
SWAYCONTROL WIRING HARNESS	9
WIRING DIAGRAMS	10
Trailer Battery	10
Ground Connections	10
12 Volt Connections	11
Electric Brake (Blue Wire) Connections	11
Left and Right Side Brake Wires	12
Trailer Wiring Overview	13
STATUS LIGHT MODULE INSTALLATION	14
SWAYCONTROL SELF DIAGNOSTICS	14
FINAL BRAKE WIRING CHECK AND START UP	15
SERVICING	16
TROUBLESHOOTING WITH THE STATUS LIGHT	17
WARRANTY TERMS AND CONDITIONS	18

# INSTALLATION INSTRUCTIONS

## PERSONNEL

The SwayControl is a safety device which is required to be installed in the caravan/trailer by suitably qualified service personnel.

### WARNING

For proper operation of the **SwayControl**, ensure that the electric brakes are adjusted and maintained in accordance with the manufacturer's recommendations in the electric brakes owner's manual.

## MOUNTING LOCATION CONSIDERATIONS

The suggested location for mounting the SwayControl is on the first trailer frame crossmember, approximately 0.3 to 3.0m behind the trailer hitching point.

The SwayControl must be mounted in the correct orientation (as indicated on the label), on either the "leading" or "trailing" edge of the crossmember. "Trailing" edge is preferred, as it provides the best protection from road debris.

### WARNING

DO NOT spray high pressure water on the **SwayControl**. The **SwayControl** is a weather sealed, water resistant unit, but it is not designed to withstand direct, high pressure spray from a power washer.

To operate correctly, the SwayControl must be securely fastened onto a vertical surface of a steel trailer. Do not fasten the SwayControl to any other trailer surface that flexes or moves from wind such as plastic covers or plastic walls.

## ORIENTATION

Ensure that the SwayControl is mounted in the correct, UP direction.

The centre of the SwayControl (marked by the orange dot on the SwayControl label) must be positioned over the centre line of the caravan/trailer.

The bottom edge of the SwayControl (as indicated by the orange line on the bottom of the SwayControl label) must be mounted parallel to the trailer beam axle.

Figure 2 further demonstrates guidance on mounting the SwayControl to the trailer.

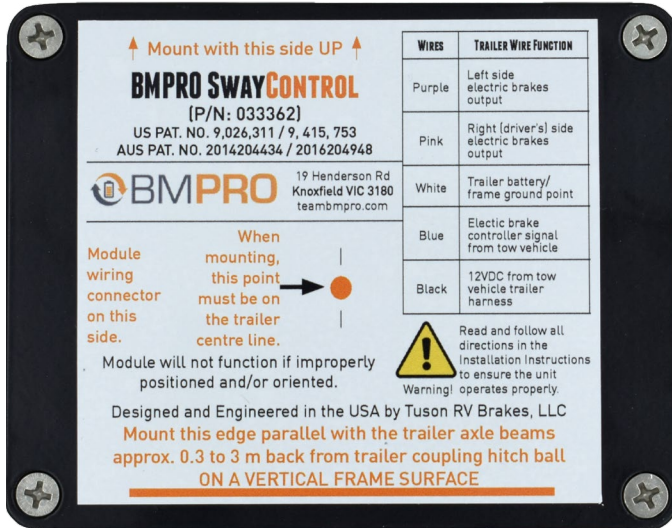

Figure 1: The SwayControl label with guidance on orientation and mounting.

## WARNING

When installed, it is essential that the **SwayControl** is orientated in the correct direction.

## MOUNTING

Mount the SwayControl to the caravan/trailer using the mounting flanges located on the sides of the unit. Use four #10 self-tapping screws (not supplied) with star lock washers to mount the SwayControl.

It is recommended that star lock washers are used and that mounting bolts are securely tightened to hold the SwayControl firmly in position and to avoid becoming loose from vibration.

## WARNING

DO NOT drill holes in the **SwayControl** for any reason. Drilling holes or puncturing the unit will void your warranty.

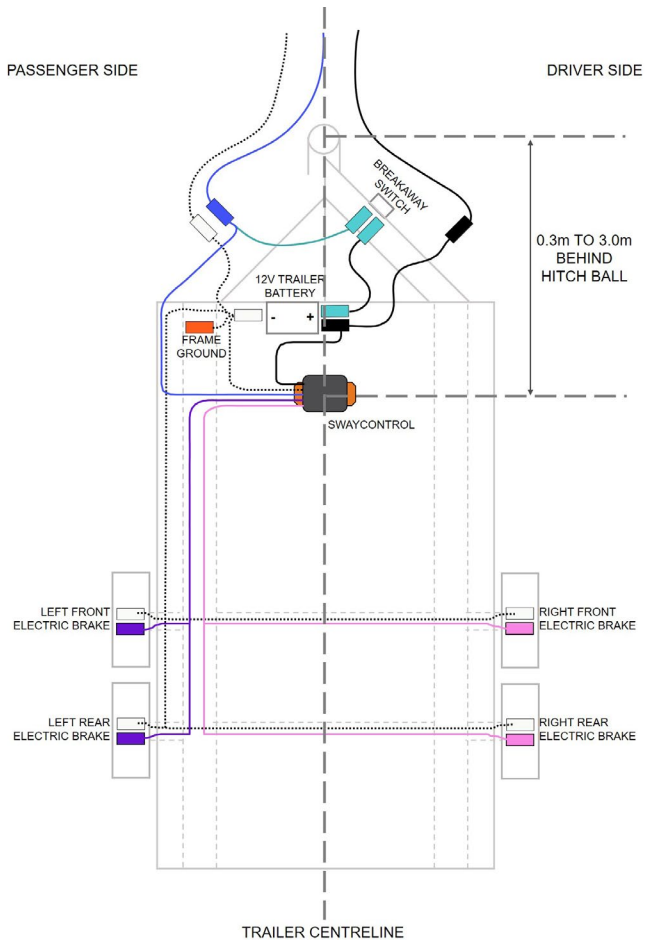

1. SWAYCONTROL MOUNTED WITH THE CORRECT SIDE IN THE UP DIRECTION
2. SWAYCONTROL CENTRE ON VERTICAL FRAME SURFACE ON TRAILER CENTRELINE
3. SWAYCONTROL EDGE PARALLEL WITH AXLE BEAMS

Figure 2: Guidance for correct mounting of SwayControl to the trailer.

Table 1: SwayControl wire harness electrical connections and required wire gauge.

SwayControl Wire	Trailer Wire Function	Required Wire Size (Minimum)
<b>PURPLE</b>	Left side electric brake output (all left side brakes)	1.8mm <sup>2</sup>
<b>PINK</b>	Right side electric brake output (all right side brakes)	1.8mm <sup>2</sup>
<b>WHITE</b>	Trailer battery/frame ground point	1.8mm <sup>2</sup>
<b>BLUE</b>	Electric brake controller signal from tow vehicle	1.8mm <sup>2</sup>
<b>BLACK</b>	12V DC from tow vehicle trailer harness	1.8mm <sup>2</sup>



# WIRING INSTRUCTIONS

## SWAYCONTROL WIRING HARNESS

The SwayControl wire harness has five wires requiring electrical connection (table 1) and one cable for the status LED light.

When making connections to the caravan/trailer's wiring harness, the desired termination is a solder joint. If the connection is not soldered, use the appropriate size and type of "crimp-type" weather sealed heat-shrink connectors, using the manufacturer's recommended crimping tools in accordance with their crimping instructions.

### **WARNING**

Taking shortcuts when connecting any wires on your trailer only increases the likelihood that some part of your electrical system will fail.

Make sure connections are durable and sealed against exposure to weather and corrosive elements. One loose connection can disable your entire trailer brake system.

### **WARNING**

Failure to use the correct wire may result in poor braking performance or brake failure. Incorrect wire size may also result in significant damage to your trailer or its components.

Undersized wire will prevent electrical circuit protection devices such as fuses or circuit breakers from functioning properly.

## WIRING DIAGRAMS

### Caravan/Trailer Battery

The caravan/trailer must be equipped with a 12V battery system of greater or equal to 50Ahr.

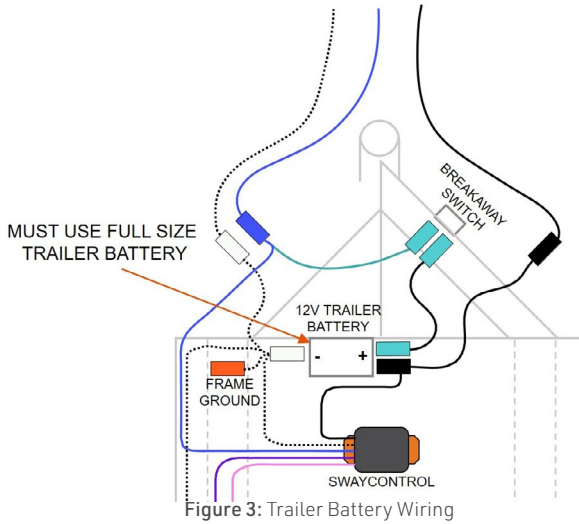

Figure 3: Trailer Battery Wiring

### Ground Connections

The caravan/trailer battery ground, the SwayControl ground and the electric brake ground wires must all be securely connected a 1.8 mm<sup>2</sup> (minimum) wire in order for the SwayControl to function properly.

These must be all fully grounded to a common point on the caravan/trailer.

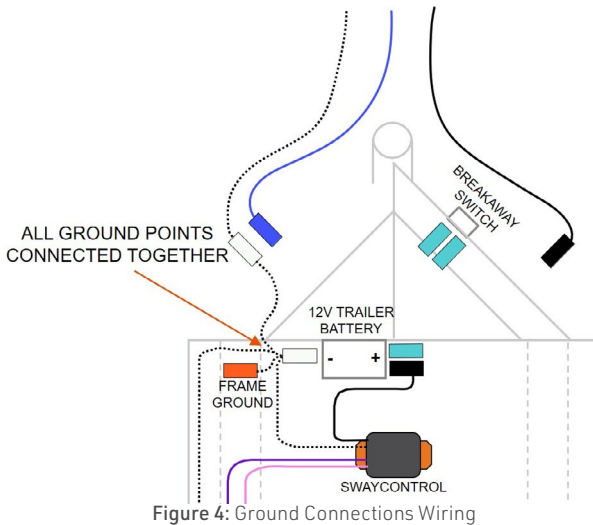

Figure 4: Ground Connections Wiring

## 12 Volt Connections

The tow vehicle 12V charge line, the 12V trailer battery terminal and the SwayControl 12V (black wire) must be securely connected together with a 1.8 mm<sup>2</sup> (minimum) wire in order for the SwayControl to function properly. The "hot" wire from the breakaway switch must be connected to the +12V terminal of the trailer battery.

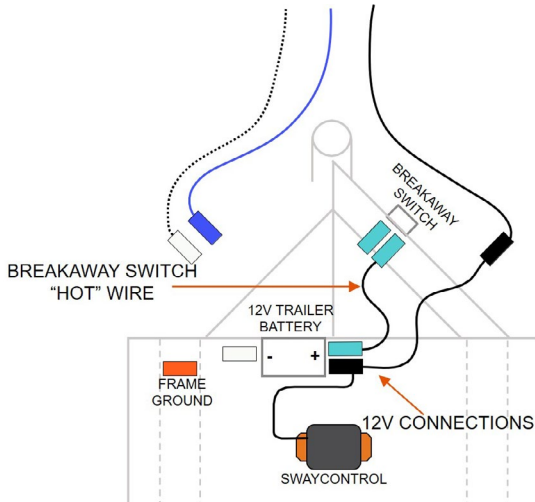

Figure 5: 12V Connections Wiring.

## Electric Brake (Blue Wire) Connections

The tow vehicle brake signal (blue) wire must be securely connected to the SwayControl brake signal (BLUE) wire as well as to the "cold" wire from the breakaway switch.

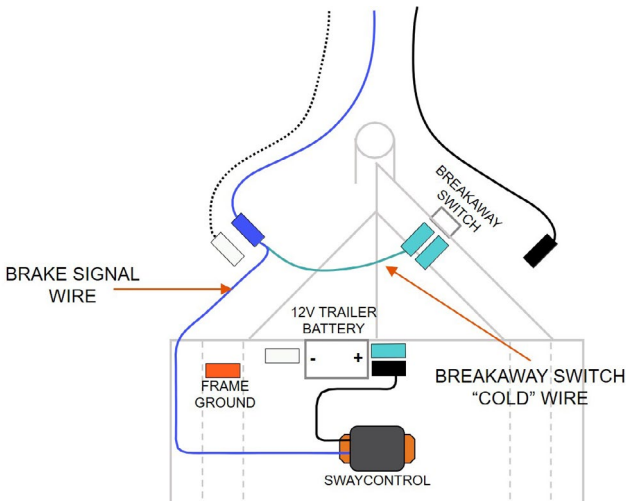

Figure 6: Electric Brake Connections Wiring

## Left and Right Side Brake Wires

The **SwayControl** operates the left and right side trailer brakes independently in order to control caravan/trailer sway. Therefore, it is very important the correct **SwayControl** wires are connected to the correct side of the brakes.

The **SwayControl** **PURPLE** wire must be connected to all left side brakes.

The **SwayControl** **PINK** wire must be connected to all right side brakes.

Failure to properly connect these wires will prevent the **SwayControl** from controlling trailer sway.

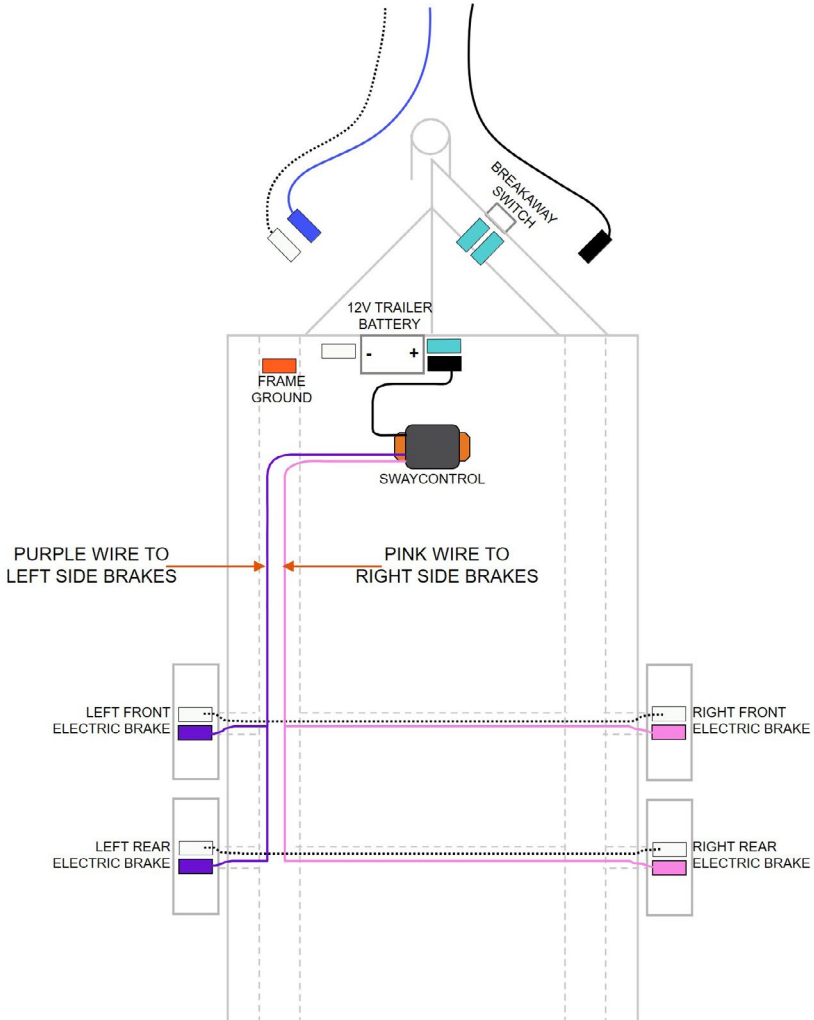

Figure 7: Left and Right Side Brake Wires.

# Caravan/Trailer Wiring Overview

The wiring diagram in figure 8 shows the **SwayControl** installed in a in a caravan/trailer.

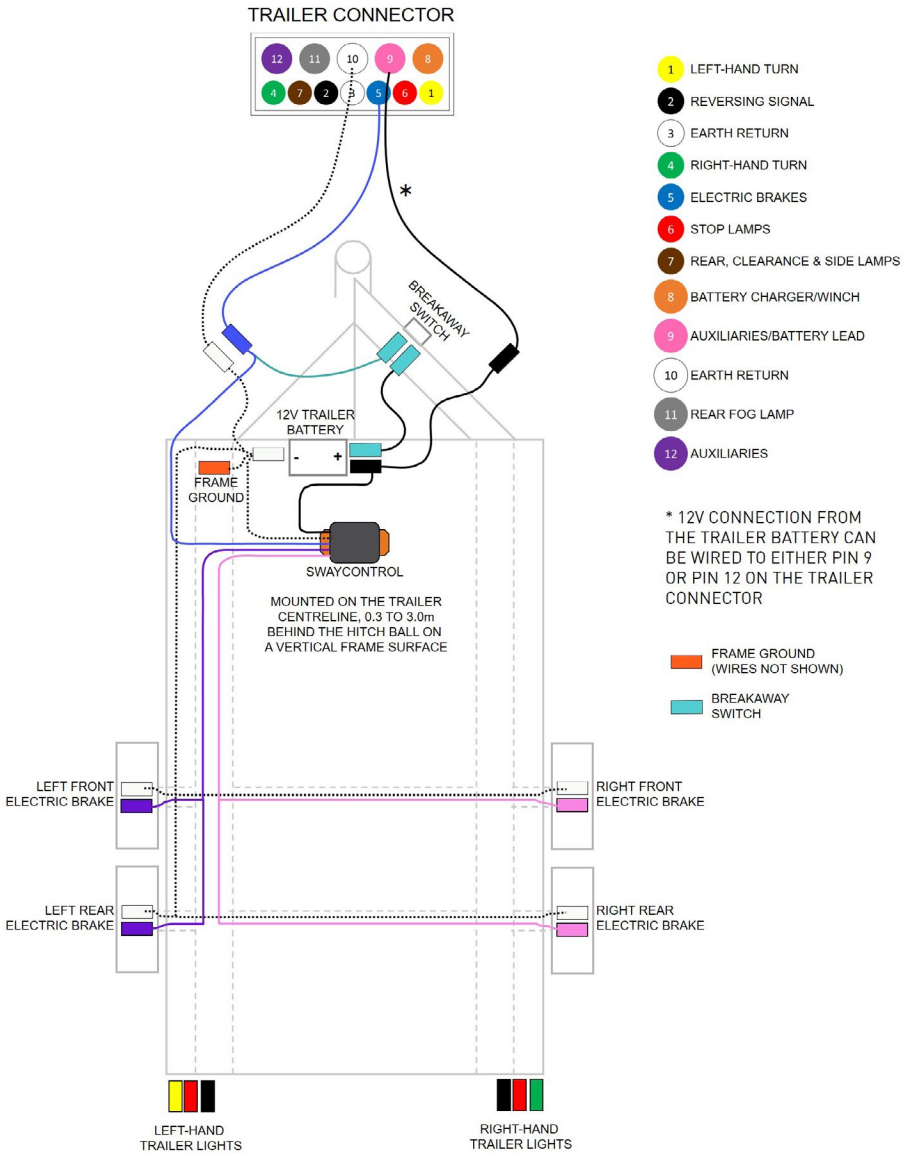

Figure 8: Wire connection to trailer plug and system overview.

# STATUS LIGHT MODULE INSTALLATION

Once wiring is completed, route the Status Light cable to the front of the caravan/trailer. Then mount the Status Light module onto a flat surface on the drawbar of the caravan/trailer using self-tapping screws.

Select a location that makes it easy to see the Status Light when looking at the front of the caravan/trailer.

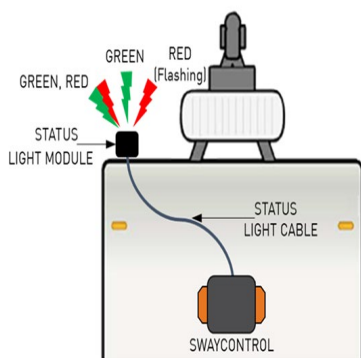

Figure 9: Troubleshooting with the Status Light

If the **SwayControl** detects a fault in the system, the Status Light will turn **RED** and the fault may be diagnosed from the **RED** Status Light flash sequence. The **SwayControl** continues checking the fault status and the **RED** Status Light will continue to flash until the fault is corrected. Once the fault has been corrected, the **GREEN** light returns.

For more information, refer to **Troubleshooting with the Status Light**.

## WARNING

When the caravan/trailer is not moving, every 60 seconds the **GREEN** light will turn off for two seconds, then turn back on. This is normal and indicates normal operation of the **SwayControl**.

If you notice the **GREEN** light turning off and on every 60 seconds and the caravan/trailer is moving, have your **SwayControl** checked by your local service centre.

# FINAL BRAKE WIRING CHECK AND START UP

To check that the **SwayControl** is wired correctly:

1. Refer to figure 10 to verify correct wiring on the left-hand side of the trailer. Ensure that **ONLY** the **PURPLE** and **WHITE** wires from the **SwayControl** are connected to the left side trailer brakes and are wired in parallel and not in series.
2. Refer to figure 10 on the following page and verify correct brake wiring on the right-hand side of the trailer. Ensure that **ONLY** the **PINK** and **WHITE** from the **SwayControl** wires are connected to the right side trailer brakes and are wired in parallel and not in series.

After performing the final brake wiring check, the **SwayControl** is ready for start-up.

The operational status of the **SwayControl** is indicated by the LED Status Light. The **SwayControl** is in sleep mode if the LED Status Light is off (dark). The **SwayControl** will start-up (wake-up) when voltage is applied to the **BLUE** wire.

Once the trailer is connected to the tow vehicle, apply the manual override on the trailer brake controller in the tow vehicle. If the **SwayControl** is installed correctly, the LED Status Light should start flickering **GREEN**.

If the LED Status Light does not come on when applying the manual override on the brake controller, refer to **Troubleshooting with the Status Light** to diagnose potential faults in the installation of the **SwayControl**.

## WARNING

When inspecting trailer wiring, it is very important that the trailer brake controller wire from the tow vehicle (blue wire) is **ONLY** connected to the **BLUE** wire on the **SwayControl** AND NOT connected directly to the trailer brakes.

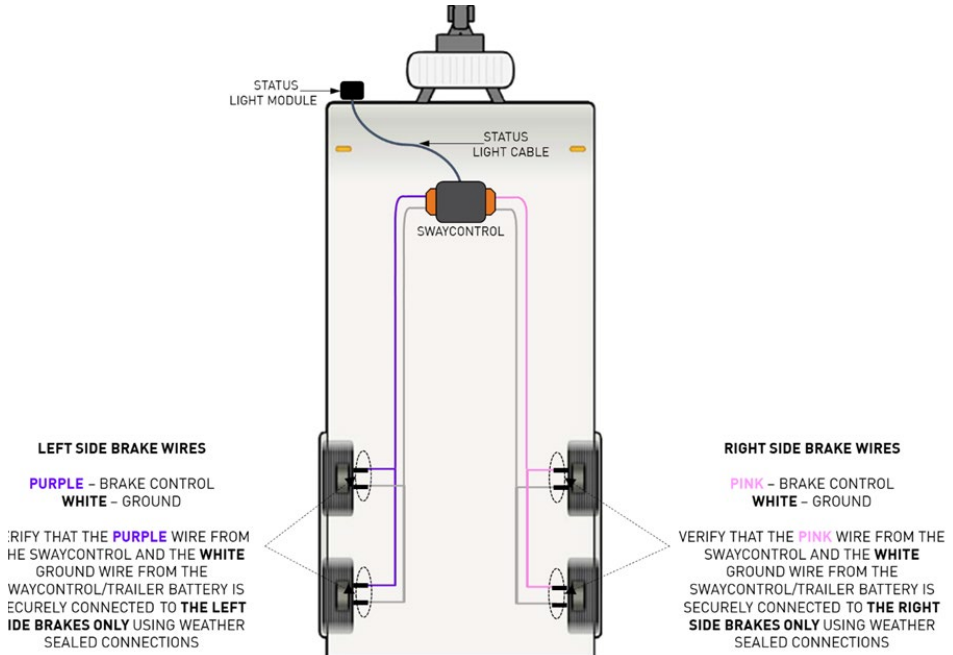

Figure 10: Verifying correct installation of the left and right side brake wires.

## SERVICING

Do not attempt to service the **SwayControl** yourself, OR dismantle, modify or repair the **SwayControl** yourself; this will void your warranty. If your **SwayControl** requires servicing, please consult your BMAPRO dealer or visit [teambpro.com](http://teambpro.com) for assistance.



# TROUBLESHOOTING WITH THE STATUS LIGHT

Need more help troubleshooting your **SwayControl**? Contact our customer service team on line at <https://teambmp.com/technical-support/> or give us a call on (03) 9763 0962.

Status Light Flash Sequence	Condition or Fault	Solution
Solid GREEN pulsing	Normal operation.	
1 GREEN flash	Module reset to manufacturer default values. Keep trailer still for 30 seconds (minimum) then drive normally.	If module does not return to normal solid GREEN pulsing light after 3 system restarts, have the unit checked at a service centre.
Continuous RED, GREEN flash	Driving on rough terrain and sway control of trailer is disabled.	Sway control of trailer is automatically disabled when driving on rough terrain. Unit will return to normal operation (GREEN light) when not on rough terrain.
No Light	Unit in "sleep" mode	Activate manual override on the brake controller to "wake-up" unit
No Light	No power after "wake-up" from brake controller	Check quality of power, ground and brake controller wire connections. Check for any blown fuses on the tow vehicle and trailer.
No Light	Over voltage, greater than 20V detected	Check power source voltage, correct voltage is 12-15V.
No Light	Low voltage, less than 3V detected	Check power source voltage, correct voltage is 12-15V. Check quality of power and ground connections.
1 RED flash	System malfunction	Service centre repair required.
2 RED flashes	Sensor malfunction - no sway control of trailer	Service centre repair required.
3 RED flashes	Left side brake short	Correct the short in left side brake wiring.
4 RED flashes	Right side brake short	Correct the short in right side brake wiring
Fast RED flashing	Low voltage, between 3 and 6V	Check quality of power and ground connections.

# WARRANTY TERMS AND CONDITIONS

Registering your BMPRO product is an important step to ensure that you receive all of the benefits you are entitled to. Please visit <https://teambmp.com> to complete the online registration form for your new product today.

1. BMPRO goods come with guarantees that cannot be excluded under Australian Consumer Law. You are entitled to a replacement or refund for major failure and for compensation for any reasonably foreseeable loss or damage. You are entitled to have the goods repaired or replaced if the goods fail to be of acceptable quality and the failure does not amount to a major failure. The benefits under this Warranty are in addition to your other rights and remedies under a law in relation to the goods to which this Warranty relates (the Australian Consumer Law).
2. BMPRO warrants products against defects for a period of two years, commencing from the original date of purchase. Proof of purchase is required before you can make a claim under this warranty.

## HOW TO PROTECT YOUR RIGHTS UNDER THIS WARRANTY:

3. The **SwayControl** is designed to be installed by a suitably qualified installer. You or your installer should carefully inspect the product before installation for any visible manufacturing defects. We accept no responsibility in addition to our consumer guarantee obligations where a product has been installed incorrectly.
4. This warranty does not extend to product failures or defects caused by, or associated with, but not limited to; failure to install or maintain correctly, unsuitable physical or operating environment, accident, acts of God, hazard, misuse, unauthorised repair, modification or alteration, natural disaster, corrosive environment, insect or vermin infestation and failure to comply with any additional instructions supplied with the product.
5. BMPRO may seek reimbursement of any costs incurred by BMPRO when a product is found to be in proper working order or damaged as a result of one or more of the warranty exclusions mentioned in point 4 of this statement.
6. To enquire or make a claim under this warranty, please follow these steps:
  - a. Prior to returning a BMPRO product, please email [customerservice@teambmp.com](mailto:customerservice@teambmp.com) to obtain a Return Material Authorisation (RMA) number.
  - b. Package and send the product to:  
**BMPRO Warranty Department**  
**19 Henderson Road**  
**Knoxfield, VIC 3180**  
Please mark RMA details on the outside of the packaging.
  - c. Please ensure the package also includes: a copy of the proof of purchase, a detailed description of the fault and your contact details including phone number and return address.
7. BMPRO will not be liable for any costs, charges or expenses incurred in the process of returning a product in order to initiate a warranty claim.



**POWERING YOUR ADVENTURES.**



**TEAM  
BMPRO  
.COM**

**BMPRO**  
+61 3 9763 0962 | [sales@teambmpro.com](mailto:sales@teambmpro.com)  
19 Henderson Rd, Knoxfield VIC 3180 Australia  
[teambmpro.com](http://teambmpro.com)