



United Air Specialists, Inc.

a CLARCOR company

OWNER'S MANUAL



**PORTABLE ELECTROSTATIC PRECIPITATOR:
SMOG-HOG® PCN**

KNOW YOUR EQUIPMENT

READ THIS MANUAL FIRST.

Your Smog-Hog® PCN should provide many years of trouble-free service. This manual will help you understand the operation of your PCN unit. It will also help you understand how to maintain it in order to achieve top performance. For quick future reference, fill in the unit information in the spaces below. Should you need assistance, call the United Air Specialists, Inc. customer service number shown below. To expedite your service, have the following information available when contacting UAS.

UAS ORDER #: _____

UNIT MODEL #: _____

UNIT SERIAL #: _____

SYSTEM ACCESSORIES:

INSTALLATION DATE: _____

UNITED AIR SPECIALISTS, INC. CUSTOMER SERVICE

1-800-252-4647

TABLE OF CONTENTS

	Page
SAFETY PRECAUTIONS	ii
1. INTRODUCTION	1
1.1 Description and Operation	1
1.2 Electrical Characteristics	1
1.3 Specifications	1
2. INSTALLATION	1
2.1. Packaging	1
2.2 Inspection Note	1
2.3 Installing the Extraction Arm Assembly	1
3. OPERATION	1
3.1 Turning the Unit On	1
3.2 Operating the Unit	2
4. MAINTENANCE AND CLEANING	2
4.1 Cleaning Schedules	2
4.2 Component Cleaning	2
4.3 Periodic Maintenance	3
4.4 Other Maintenance	3
5. TROUBLESHOOTING GUIDE	3
5.1 How to Check High Voltage	4
5.2 Checking for Ionizer High Voltage	4
5.3 Checking for Cell High Voltage	4
5.4 Determining the Loss of High Voltage	5
5.5 Checking Air Movement (Blower and Drive)	5
6. REPLACEMENT PARTS	6
6.1 Ordering Parts	6
6.2 Returning Parts	6
7. TROUBLESHOOTING FLOWCHART	7
8. PCN PARTS LIST	8
9. WIRING DIAGRAM	9

SAFETY PRECAUTIONS

We have provided many important safety messages in this manual on your Smog-Hog PCN. Always read and obey all safety messages.



This is the safety alert symbol.

This symbol alerts you to potential hazards that can kill or hurt you and others. All safety messages will follow the safety alert symbol and the word “DANGER” “WARNING” or “CAUTION”. These words mean:



Indicates a hazardous situation which, if not avoided, will result in death or serious injury.



Indicates a potentially hazardous situation which, if not avoided, could result in death or serious injury.



Indicates a potentially hazardous situation which, if not avoided, may result in minor or moderate injury.



CAUTION used without the safety alert symbol indicates a potentially hazardous situation which, if not avoided, may result in property damage.

IMPORTANT SAFETY INSTRUCTIONS

WARNING

To reduce the risk of fire, electric shock, or injury when using your air cleaner, follow these basic precautions:

- Wear protective clothing and safety glasses when handling collector components or servicing the unit.
- Use proper lifting and rigging equipment to install your electronic precipitator.
- The electronic precipitator should be properly grounded prior to servicing.
- Disconnect power before servicing.
- Replace all access panels before operating.
- Do not operate the unit with component doors open.
- Electrical connections should only be made by qualified personnel and be in accordance with local and national codes and regulations.
- Do not use in explosive atmospheres.
- Do not collect emissions which are explosive
- Use non flammable cleaners.
- Keep flammable materials and vapors, such as gasoline, away from unit.
- The unit should be inspected frequently and contaminants removed to prevent excessive accumulation which may result in flash-over or fire damage.
- Operate only in a safe and serviceable condition.
- Operating temperature to the air stream should not exceed 120° F.

1. INTRODUCTION

1.1 DESCRIPTION AND OPERATION

The Smog-Hog PCN is a portable electronic air cleaner designed to eliminate particulate as it is generated.

Contaminant is captured at its source by a unit-mounted hood, then conveyed through a duct network to the precipitator where it is collected. Clean air is then re-circulated back to the work area.

As air approaches the precipitator, it passes through a reusable, aluminum mesh mechanical pre-filter which aids air distribution and removes large particles.

Pre-filtered air then passes through an ionizer where particles are charged by corona discharge from a series of small diameter charged tungsten wires centered between grounded plates. Particles then pass through a collection cell, consisting of alternately charged and grounded parallel aluminum plates. Charged plates at the same polarity as the charged particles repel the particles toward the grounded plates which, in turn, attract the particles. Air next passes through a centrifugal blower where it is exhausted vertically through a centrifugal blower where it is exhausted vertically through an adjustable outlet grille, back to the work space.

An integrally mounted power pack converts 115 volt, single-phase AC power to the high voltage DC required for ionizer and collection cell operation.

1.2 ELECTRICAL CHARACTERISTICS

The unit is rated for 115 VAC (volts alternating current), single phase, 60 Hz operation. It has a 10' power cord with grounded plug and internal high voltage wiring.

1.3 SPECIFICATIONS

Power Requirements:	115V, single phase, 60 Hz*, 7.6 amps		
Precipitator Voltage:	Ionizer: 11,000 volts DC Collection Cell: 6,000 volts DC		
Motor:	1/2 HP, totally enclosed		
Weight:	400 lbs. (181 Kg)		
Overall Dimensions:	Length	Width	Height
	42"	28"	44"
	106.7 cm	71.1 cm	111.8 cm
Cabinet:	16-gauge steel		
Air Cleaning Capacity:	1,000 CFM*** (1699M ³ H)		
Capture Distance:	18" (45.7 cm) max. recommended		
Swing Arm Reach:	132", 360° radius		
Duct:	8" diameter x 132" long		
Hood Size:	18" x 12" oval		
Wheels:	Two 8" (20.3 cm) wheels and two 5" (12.7 cm) Swivel locking casters		

*50 Hz optional
** Factory set. Nominal airflow rating

2. INSTALLATION

2.1 PACKAGING

The Smog-Hog PCN is shipped in three containers. One consists of the main cabinet and operating components. The second is the factory-assembled extraction arm with duct in place. The third is the hood.

2.2 INSPECTION NOTE

Upon receipt of your unit, check for any shipping damage. A damaged carton indicates that the equipment may have received rough handling during shipping that may have caused possible internal damage. Notify your delivery carrier and enter a claim if any damage is found.

2.3 INSTALLING THE EXTRACTION ARM ASSEMBLY

The top of the PCN cabinet has eight 5/16-18 threaded studs protruding upward from the cabinet, and equally spaced around the air entry opening. The mating extraction arm mounting flange is ready for installation, and the mounting hardware (nuts and split ring lock washers) is in a plastic bag inside the main cabinet. The extraction arm assembly is approximately 50 lbs, but because of its size, may be best positioned by two people.

The extraction arm support spring is in place on the assembly, with a protective shipping retainer box strapped in place (these must be removed before operating the unit). All pivot points are tightened slightly to keep arms from moving during handling. This assembly is shipped for installation so that the arm nearest the cabinet is in the vertical position when the bearing flange is being bolted down. With this arm extending up from the top of the cabinet, a ceiling height of about 10' is required for adequate clearance. Refer to the SA Installation and Owner's Manual for instructions on assembling the extraction arm or making field adjustments.

 CAUTION
Sharp pulls on the arm or hood should be avoided since damage to the arm components could result.

3. OPERATION

 CAUTION
Do not use the PCN where high concentrations of flammable materials may be present. If in doubt, consult UAS.

3.1 TURNING THE UNIT ON

The PCN is provided with 10' of pre-wired type 3-SJ electrical cord with a three-prong male plug. To operate the unit:

1. Plug the unit into a grounded 115V/1/60 Hz electrical receptacle.
2. Lock wheel casters on unit to secure location.

⚠ CAUTION

Do not attempt to move the PCN unit by pulling on the extraction arm or hood. Use handles on the back of the unit to pull the PCN around the work area.

3. Turn the unit on by flipping the toggle switch to the "on" position. The indicator lamp should glow, and the unit's drive fan should rotate. If either of these do not function, refer to the Troubleshooting section within this manual.
4. The unit is now ready for use.

3.2 OPERATING THE UNIT

The PCN moves 1,000 CFM of contaminated air away from the source of generation. For good contaminant capture, a few simple guidelines apply:

1. Locate the unit, arm and hood in anticipation of the job(s) intended. Know the limitations of the unit and the job.
2. Minimize the influence of cross drafts from outside air sources.
3. Position the hood slightly higher than the source, with the face of the hood approximately 45° from horizontal. The hood shape is designed for high velocity pick-up. It should be located no further than 18" from the contaminant source.

4. MAINTENANCE AND CLEANING

4.1 CLEANING SCHEDULES

To maintain maximum efficiency, use the following suggested cleaning schedules:

1. Weld Smoke

- Weekly: Using compressed air, gently blow components with high velocity air. Be careful not to damage plates.
- Monthly: Soak components using instructions outlined below. Collected contaminant varies greatly from one application to another, so cleaning frequency should be monitored and adjusted to maintain unit efficiency.
- The collecting pan should be emptied before dust reaches the top of the pan's internal baffles. Failure to do so will cause re-entrainment of previously collected dust into the airstream.

2. Oil Smoke

- Clean as required. When components become dirty, the indicator light will dim, and arcing of components will become frequent. Smoke may become visible from the PCN exhaust. Soak cleaning of components (see instructions below) at least every three months is recommended.

- The collecting pan should be emptied as required to prevent overflow.

4.2 COMPONENT CLEANING

1. Turn off the PCN and depress both push-to-test buttons to remove residual charge from the components.
2. Open the door and slide components out of the cabinet. If the collected particulate is dry, gently tap the components to remove loose particles. Components can be cleaned by soaking in a hot solution of industrial-grade cleaner that is safe for use with the aluminum components in the PCN.

It is extremely important to thoroughly wipe clean all high-voltage insulators whenever the components are cleaned. Use a non-abrasive cloth to protect glaze on the ceramic insulators.

For inorganic (e.g., iron oxide from welding) residue removal, acidic-type cleaners with a pH from 1 to 1.5 are most efficient. To clean organic (most petroleum-base oils) materials, alkaline base detergents with pH from 10 to 12 are effective. Consult your supplier for specific recommendations and application instructions. Any cleaner must contain an aluminum inhibitor or be otherwise made safe for use with aluminum.

⚠ CAUTION

Do not use temperatures exceeding 160° F. Do not steam clean, as this may cause the aluminum plates to warp. If detergent other than Smog-Hog brand is used, care must be taken to ensure that it contains an inhibitor so that it does not attack the aluminum components.

Let the aluminum components soak for approximately 30 minutes, followed by agitation in the solution to remove loosened dirt. If agitation is not possible, soak time should be increased to compensate.

3. After removing components from the detergent bath, immediately flush away any residue and rinse thoroughly with hot water.
4. Shake off excess water and let components stand in vertical position until they are dry to the touch.
5. Re-install components into the PCN cabinet, close the door and turn unit on. If the unit crackles excessively, or the indicator light fails to come on, open the access door and continue to run the blower to allow the components to dry thoroughly.

4.3 PERIODIC MAINTENANCE

1. At least every three months (or whenever components are removed for soak cleaning), wipe clean the ionizer and collection cell contact springs and insulators located above the pre-filter. Clean out the interior cabinet area.
2. With the PCN unplugged, brush clean all wiring connections at the power pack and switches.
3. Check for drive belt tension and wear. One half inch movement (with finger pressure) at the belt mid-point indicates correct tension. Refer to Figure 1.

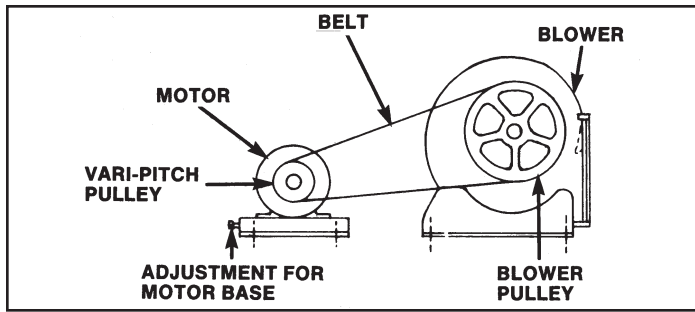

Figure 1
Motor/Blower Assembly

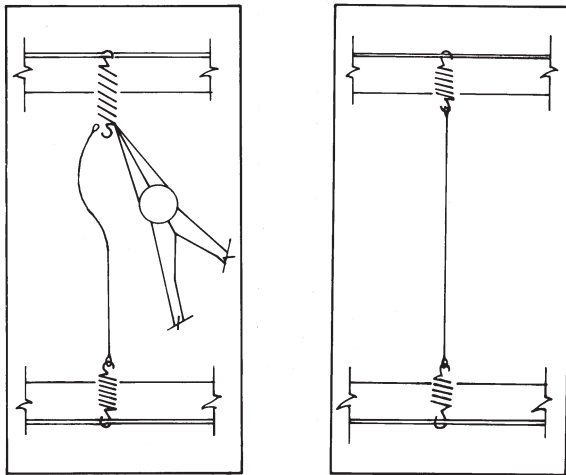

Figure 2
Ionizer Wire/Spring Installation

4.4 OTHER MAINTENANCE

Instructions for replacing an ionizer wire:

1. Remove the damaged wire from each spring.
2. Replace spring if damaged.
3. Loop one end of the new wire over the bottom spring, pull down top spring with pliers and loop the top end of the wire over the spring hook. Refer to Figure 2.
4. Release the spring gently. The wire is now taut and automatically centered.

Note: In the event replacement wire is not immediately available, remove broken wire and springs from the assembly to allow operation until new parts can be installed.

CAUTION

The following section is for the use of trained service personnel only. The following procedures will expose hazardous live and moving parts. Disconnect the air cleaner before proceeding.

5. TROUBLESHOOTING GUIDE

Tools Required

1. Screwdriver: 8" or longer with insulated handle.
2. Volt-Ohmmeter: used to check low voltage input (120 VAC) and continuity (OHMS).
3. High Voltage Probe: used to check high voltage power supply, minimum range from 0-15 KVDC.

*Refer also to the Troubleshooting Flow Chart on page 6.

Normal Operation

1. Turning the toggle switch on allows 115V/1/60Hz supply to the blower and high voltage power pack (see Wiring Diagram, page 8).
2. The indicator light is on, and its glow is bright and steady, indicating high voltage is present at the power pack.
3. Air draw through the welding hood to the PCN unit is adequate.
4. Unit is clean.

Abnormal Operation

1. The indicator light is off even though the unit blower is running.

Possible Cause:

- a. The light bulb is burnt out.
- b. The high voltage power pack is defective.
- c. A dead short exists in the ionizer and/or collection cell circuit.
- d. Components need cleaning.

Corrective Action:

- a. Replace the bulb.
 - b. Replace the high voltage power pack.
 - c. Troubleshoot and remove the short (see how to troubleshoot ionizer and cell circuit, page 4).
 - d. Remove components and clean.
2. Indicator light is flickering on/off with audible arcing inside the cabinet.

Possible Cause:

- a. An intermittent short exists in the ionizer and/or cell circuit.
- b. Components need cleaning.

Corrective Action:

- a. Remove the ionizer and cell, inspect for the cause.
 - b. Remove components and clean.
3. The indicator light is on but the unit does not have adequate air movement.

Possible Cause:

- The drive belt is loose or off the pulley.
- The drive motor has malfunctioned.
- The hood throat screen has plugged.
- Components need cleaning.
- The diffuser screen has plugged.

Corrective Action:

- Tighten or replace the belt.
 - Repair or replace the motor.
 - Remove the blockage from the screen.
 - Remove and clean the components.
 - Clean the diffuser screen.
- The indicator light and the unit blower are both off.

Possible Cause:

- The toggle switch is in the "off" position.
- The unit does not have 115V/1/60Hz input.
- The door safety switch on the inside of the collection component access door is defective or not activated.
- The access panel safety switch, located behind the blower access panel, is defective or not activated.
- Cabinet internal wiring has an open circuit.

Corrective Action:

- Reset the toggle switch.
- Determine the cause of input voltage loss.
- Re-activate the safety switch or replace the defective switch.
- Activate the safety switch or replace the defective switch.
- Determine the location of the open circuit and correct.

5.1 HOW TO CHECK HIGH VOLTAGE

The indicator light on the unit will be on high if high voltage is present at the cell and ionizer terminals on the power pack. If the light is out, either the voltage applied to the components is below a good operating level or the light circuit is not functioning.

CAUTION

If push-to-test buttons are not depressed, a residual DC voltage will remain on the high voltage components for a short period of time after the access door is opened. To ensure safe handling, components should be grounded to the cabinet by means of an insulated handle screwdriver.

5.2 CHECKING FOR IONIZER HIGH VOLTAGE

(See Figure 3)

- Connect the ground wire on the handle of high voltage probe to the edge of the collection cell or other convenient cabinet ground.
- Place probe tip on the ionizer wire support rod.
- Depress the door safety switch to activate the power supply. The voltage through the ionizer should read approximately 11.0 KVDC.

5.3 CHECKING FOR CELL HIGH VOLTAGE

(see Figure 4)

- Connect the ground wire on the handle of high voltage probe to the edge of the collection cell.
- Place the tip of the probe at the center (metal support rod end) of the cell insulator.
- Depress the door safety switch to activate the power supply.
- The voltage through the cell should read 5 to 6 KVDC.

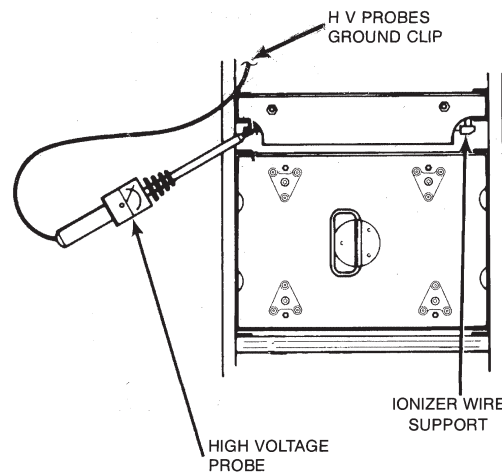

Figure 3
Ionizer High Voltage Check

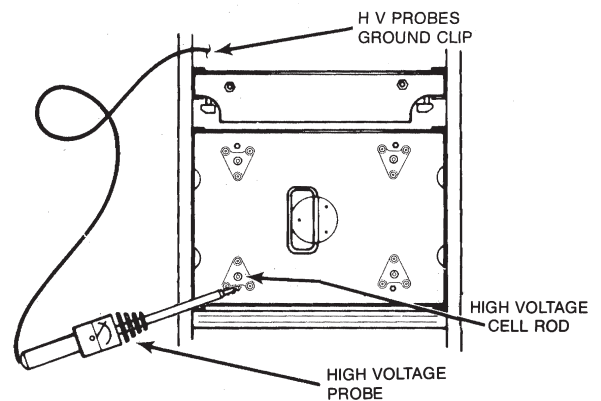

Figure 4
Cell High Voltage Check

5.4 DETERMINING THE LOSS OF HIGH VOLTAGE

As components build up dirt, the indicator light dims then goes out at a point approximately 3.5KV cell voltage. If satisfactory operating voltage is present at the ionizer and cell and the light is out, the problem is either a defective indicator light or light circuit.

If no voltage is present at the cell, and the indicator light is out:

1. Remove the cell and depress the door interlock switch.
 2. If the indicator light comes on, the problem is in the cell. Check for the following:
 - a. Excessive build up between cell plates.
 - b. Something lodged between the cell plates, bowed or bent plates, etc.
 - c. Cracks in any of the eight cell insulators, carbon tracking or other insulator damage.
 3. If the indicator light remains off with the cell out of the unit, remove the ionizer and activate the power supply.
 4. If the indicator light comes on, the problem is in the ionizer. Check for the following:
 - a. Broken or loose ionizer wires.
 - b. Excessive build up on insulator(s).
 - c. Cracked or broken insulator(s).
 5. If the light remains out with both the ionizer and cell removed, remove the side access panel and check out the high voltage power pack. See Figure 6.
 - a. Remove both high voltage leads from the end of the power pack.
 - b. Measure high voltage (use probe) at terminal No. 8 (output to ionizer) and terminal No. 7 (output to collector).
 - c. If no voltage is present or voltage is below minimum, replace the power pack.
- Note:** Minimum reading with high voltage wires removed: 11KV at terminal No. 8 (ionizer) and 7KV at terminal No. 7 (collector).
6. If voltage is present and within limits, check for:
 - a. Short in the high voltage lead wires.
 - b. Cracked or broken cabinet insulators.

5.5 CHECKING AIR MOVEMENT (BLOWER AND DRIVE)

1. If the unit has deficient airflow:
 - a. Check for any type of restriction in the pick-up hood, flex hose or main unit.
 - b. Remove the pre-filter, cell and ionizer components and check for an obstruction at the diffuser plate directly above them. If none is present, check the components for excessive dirt build up.

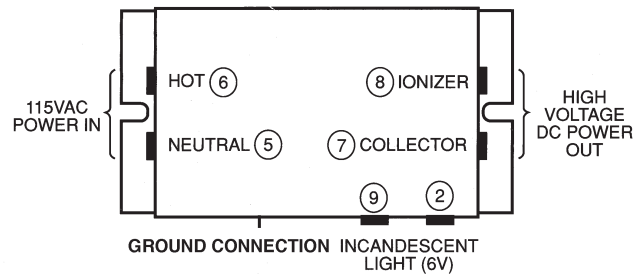

Figure 5
Power Pack Terminal Connections

- c. If components are clean, remove the side access panel and check for:
 - i. Loose or broken belt
 - ii. Defective drive motor
 - iii. Loose pulley

⚠ CAUTION

The belt should have approximately 1/2" of play when depressed with one finger. Having the belt set too loose causes slippage and reduces airflow. Having the belt set too tight causes an over current condition in the motor. The resulting higher temperature shortens motor winding and bearing life.

6. REPLACEMENT PARTS

6.1 ORDERING PARTS

Replacement parts can be ordered from your local representative or from UAS direct. To order parts from UAS, contact Customer Service at 1-800-252-4647. Please have the following information available for prompt service:

1. Unit model number
(on nameplate, blower access door)
2. Unit serial number
(on nameplate, blower access door)
3. Part number of part(s) (see parts list)

6.2 RETURNING PARTS

When returning a defective part under warranty, you need to call UAS for a Return Material Authorization (RMA) number. This control number assures you receive prompt service, so it should appear prominently on the package being returned.

7. TROUBLESHOOTING FLOWCHART

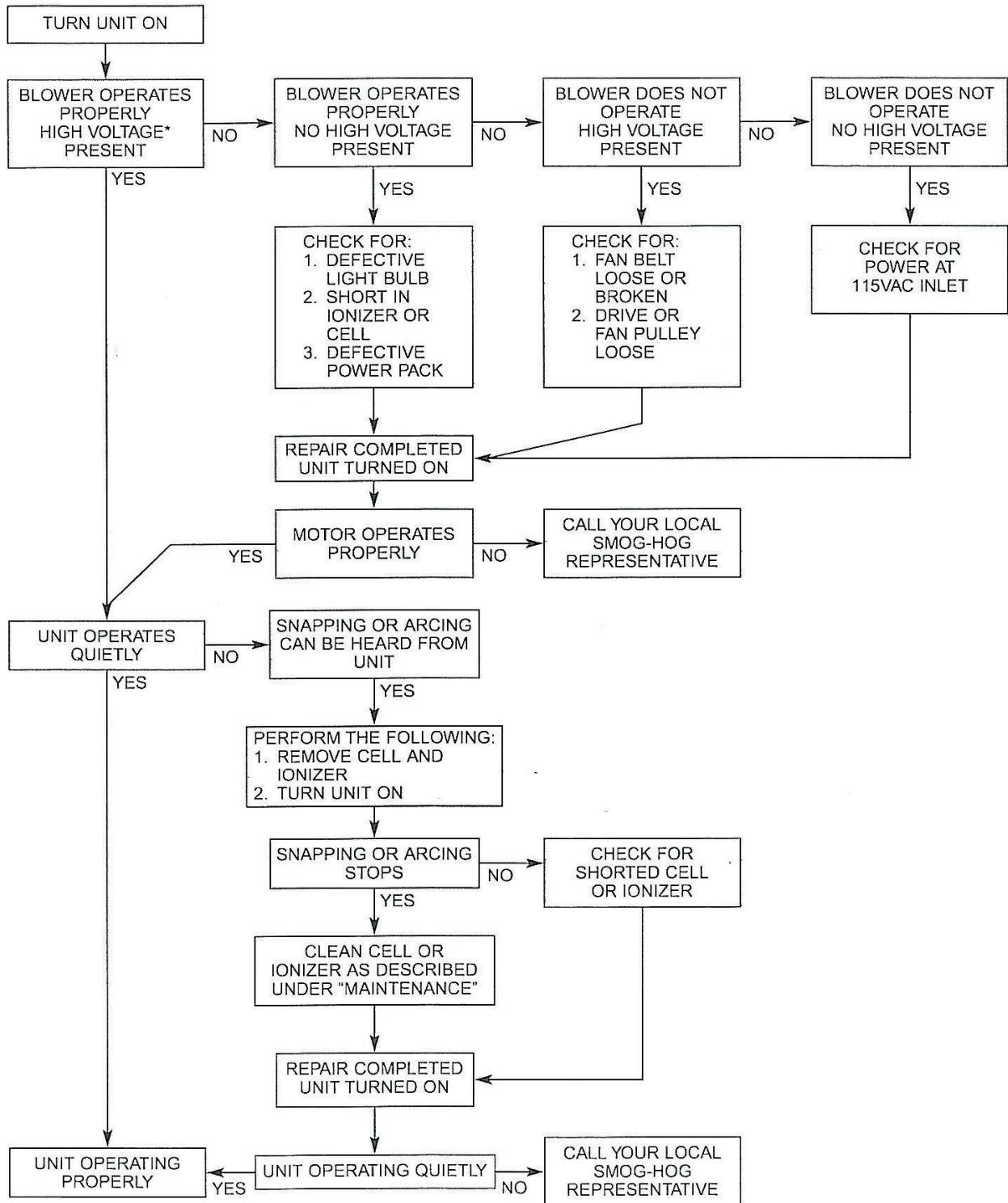

*ILLUMINATED LIGHT INDICATES HIGH VOLTAGE PRESENT

8. PCN PARTS LIST

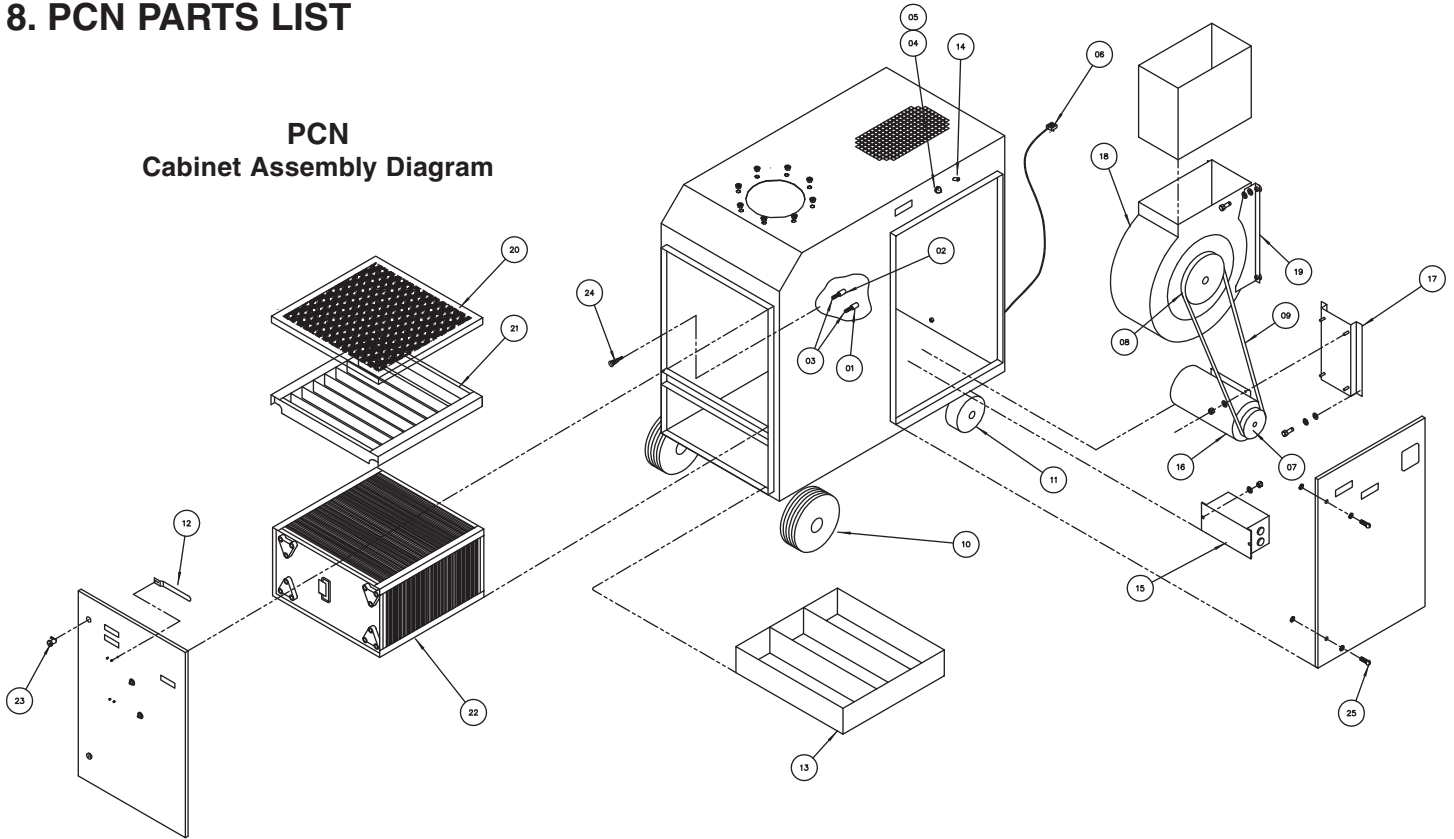

Item	Part No.	Description	Quantity
1	37-0001	Insulator, Cell	1
2	37-0002	Insulator, Ionizer	2
3	36-0014	Spring, H.V. Contact	2
4	20-0467	Lamp (6 Volt)	1
5	20-0260	Lens Cover	1
6	20-0288	Power Cord	1
7	31-0017	Motor Pulley	1
8	31-0102	Blower Pulley	1
9	31-0083	Drive Belt	1
10	17-0010	Wheel, 8"	2
11	17-0012	Caster, 5" Swivel	2
12	03-1000	Short-Out Spring Assly	1
13	18-1931	Dust Pan	1
14	20-0326	Toggle Switch	1
15	21-1216	Power Pack	1
16	22-0001	Motor, 1/2 HP (Tot. Encl.)	1
17	23-0001	Motor Base	1
18	32-0171	Blower	1
19	32-0172	Blower Support	2
20	33-0001	Pre-filter, Alum. Mesh	1
21	02-0044	Ionizer	1
22	02-2339	Collection Cell	1
23	39-0124	Door Latch (Component)	2
24	36-0016	Ground Spring	2
25	30-0536	Door Latch (Mtr./Blr.)	2

9. WIRING DIAGRAM

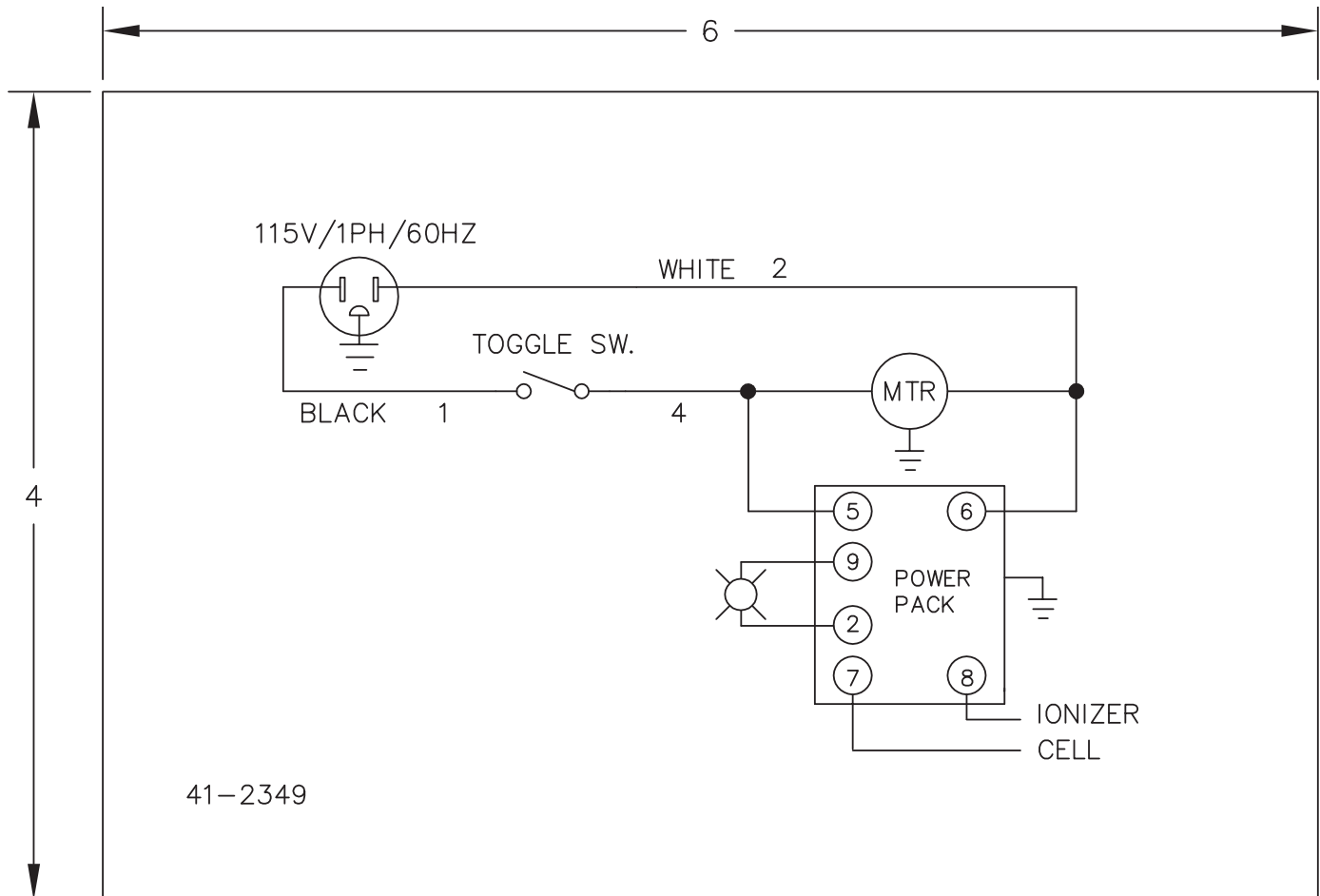

Notes:

1. Must be U.L. recognized marking & labeling system for use on epoxy paint.
2. Label to be adhesive backed with black characters on white stock with clear plastic laminate.
3. Minimum character height shall be 3/32", except 41-2349 shall be 1/16 in.
4. Vendor's U.L. recognized mark must be per the U.L. recognized component directory.
5. Alt. size 3 x 5

**PCN
Wiring Diagram**

This page intentionally left blank

This page intentionally left blank

**UNITED AIR SPECIALISTS, INC.
LIMITED WARRANTY**

UAS warrants to the original purchaser that all equipment will be free from defects in materials and workmanship for one year from the date of shipment from UAS (three years for Smokeeter® and VisionAir™ models other than CC and DC series) and that major structural components on SFC and MCB series will be free from defects in materials and workmanship for ten years from the date of shipment from UAS. This warranty applies only if equipment is properly installed, maintained, and operated under normal conditions and does not apply to damage caused by corrosion, abrasion, abnormal use or misuse, misapplication, or normal wear and tear. This warranty will be void with respect to equipment that is subject to unauthorized repairs or modifications. UAS makes no warranty as to goods manufactured or supplied by others. This warranty is subject to any limitations in UAS' quotation and may not be modified except by a written instrument signed by the President or Vice President of Sales of UAS.

THIS WARRANTY IS EXCLUSIVE AND IN LIEU OF ALL OTHER WARRANTIES, WHETHER WRITTEN, ORAL OR IMPLIED, INCLUDING ANY IMPLIED WARRANTY OF MERCHANTABILITY, FITNESS FOR A PARTICULAR PURPOSE OR NONINFRINGEMENT.

As Purchaser's exclusive remedy for any defects in the equipment, UAS will exchange or repair any defective parts during the warranty period, provided such parts are returned, prepaid, to UAS' factory. The obligation of UAS is limited to furnishing replacement parts F.O.B. UAS' factory or making repairs at UAS' factory of any parts that are determined, upon inspection by UAS, to be defective. In no event will UAS be responsible for labor or transportation charges for the removal, reshipment or reinstallation of the parts.

IN NO EVENT WILL UAS BE RESPONSIBLE FOR ANY SPECIAL OR CONSEQUENTIAL DAMAGES.



United Air Specialists, Inc.

a CLARCOR company

4440 Creek Road • Cincinnati, Ohio 45242 USA
National Phone: 1-800-252-4647
Telephone: (513) 891-0400 • Fax: (513) 891-4882
www.uasinc.com