



VOLVO C30

OWNERS MANUAL



WEB EDITION

DEAR VOLVO OWNER

THANK YOU FOR CHOOSING VOLVO

We hope you will enjoy many years of driving pleasure in your Volvo. The car has been designed for the safety and comfort of you and your passengers. Volvo is one of the safest cars in the world. Your Volvo has also been designed to satisfy all current safety and environmental requirements.

In order to increase your enjoyment of the car, we recommend that you familiarise yourself with the equipment, instructions and maintenance information contained in this owner's manual.





00 Introduction

Important information.....	8
Volvo and the environment.....	11

00



01 Safety

Seatbelts.....	16
Airbag system.....	19
Airbags (SRS).....	20
Activating/deactivating the airbag (SRS)*.....	23
Side airbags (SIPS bags).....	25
Inflatable Curtain (IC).....	27
WHIPS.....	28
When the systems deploy.....	30
Crash mode.....	31
Child safety.....	32

01



02 Instruments and controls

Overview, left-hand drive cars.....	40
Overview, right-hand drive cars.....	42
Driver's door control panel.....	44
Combined instrument panel.....	45
Indicator and warning symbols.....	46
Information display.....	50
Electrical socket.....	52
Lighting panel.....	53
Left-hand stalk switch.....	55
Right-hand stalk switch.....	58
Cruise control*.....	61
Keypad in the steering wheel*.....	63
Steering wheel adjustment, hazard warning flashers.....	64
Parking brake.....	65
Power windows.....	66
Windows, rearview and door mirrors.....	68
Power sunroof*.....	72
Personal preferences.....	74
HomeLink® *.....	76

02



03 Climate control

General information on climate control.....	82
Manual climate control, AC.....	84
Electronic climate control, ECC*.....	87
Air distribution.....	90
Fuel-driven engine block heater and passenger compartment heater*.....	91
Fuel-driven auxiliary heater* (diesel).....	94



04 Interior

Front seats.....	98
Interior lighting.....	103
Storage spaces in the passenger compartment.....	106
Rear seat.....	110
Cargo area.....	111



05 Locks and alarm

Remote control key with key blade.....	116
Active locks.....	119
Keyless drive*.....	120
Battery in remote control key.....	123
Locking and unlocking.....	124
Alarm*.....	127



06 Starting and driving

General.....	132
Refuelling.....	134
Starting the engine.....	135
Starting the engine – Flexifuel.....	137
Keyless drive*.....	139
Manual gearbox.....	140
Automatic gearbox.....	142
Brake system.....	146
DSTC – Stability and traction control system*.....	148
Park Assist*.....	150
BLIS* – Blind Spot Information System. .	152
Towing and recovery.....	156
Start assistance.....	158
Driving with a trailer.....	159
Towing equipment*.....	161
Detachable towbar*.....	163
Loading.....	167
Adjusting headlamp pattern.....	168



07 Wheels and tyres

General.....	172
Tyre pressure.....	176
Warning triangle* and spare wheel*	179
Changing wheels.....	181
Emergency puncture repair*.....	183



08 Car care

Cleaning.....	190
Touching up paintwork.....	193
Rustproofing.....	194



09 Maintenance and service

Volvo service.....	198
Self-maintenance.....	199
Bonnet and engine compartment.....	200
Oils and fluids.....	202
Wiper blades.....	207
Battery.....	209
Replacing bulbs.....	211
Fuses.....	218



10 Infotainment system

General.....	228
Audio functions.....	230
Radio functions.....	234
CD functions.....	239
Menu structure – audio system.....	242
Phone functions*.....	243
Menu structure – phone*.....	250
Bluetooth handsfree*.....	253



11 Specifications

Type designation.....	260
Dimensions and weights.....	263
Engine specifications.....	266
Engine oil.....	267
Fluids and lubricants.....	271
Fuel.....	274
Catalytic converter.....	278
Electrical system.....	279
Type approval.....	281



12 Alphabetical Index

Alphabetical Index..... 282

12





Important information

Reading the Owner's Manual

Introduction

A good way of getting to know your new car is to read the owner's manual, ideally before your first journey. This will give you the opportunity to familiarise yourself with new functions, to see how best to handle the car in different situations, and to make the best use of all the car's features. Please pay attention to the safety instructions contained in the manual.

The equipment described in the owner's manual is not present in all cars. In addition to standard equipment, this manual also describes options (factory fitted equipment) and certain accessories (retrofitted extra equipment). If you are uncertain over what is standard or option/accessory then we recommend that you contact your Volvo dealer.

Volvo cars are adapted for the varying requirements of different markets, as well as for national or local legal requirements and regulations.

The specifications, design features and illustrations in this owner's manual are not binding. We reserve the right to make modifications without prior notice.

© Volvo Car Corporation

Option

All types of option/accessory are marked with an asterisk * .

The range of options/accessories for the different car models varies depending on the market. The majority of options are factory fitted and cannot be retrofitted, accessories are retrofitted.

We recommend that you contact your authorised Volvo dealer for more information.

Special texts



WARNING

Warning texts advise of a risk of personal injury.



IMPORTANT

Important texts advise of a risk of material damage.



NOTE

NOTE texts give advice or tips that facilitate the use of features and functions for example.

Footnote

There is footnote information in the owner's manual that is located at the bottom of the page. This information is an addition to the text that it refers to via a number. If the footnote refers to text in a table then letters are used instead of numbers for referral.

Message texts

There are displays in the car that show text messages. These text messages are highlighted in the owner's manual by means of the text being slightly larger and printed in grey. Examples of this are in menu texts and message texts on the information display (e.g. **Audio settings**).

Decals

The car contains different types of decal which are designed to convey important information in a simple and clear manner. The decals in the car have the following descending degree of importance for the warning/information.



Important information

Warning for personal injury



Black ISO symbols on yellow warning field, white text/image on black message field. Used to indicate the presence of danger which, if the warning is ignored, may result in serious personal injury or fatality.

Risk of property damage

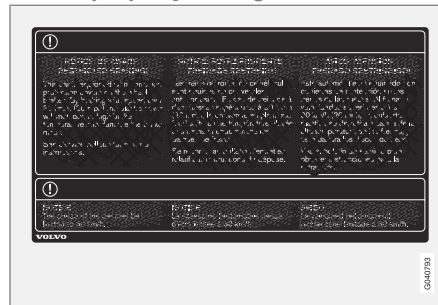

White ISO symbols and white text/image on black or blue warning field and message field. Used to indicate the presence of danger which, if the warning is ignored, may result in damage to property.

Information

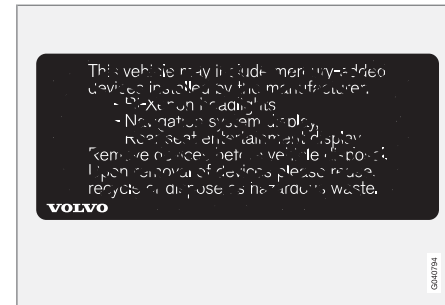

White ISO symbols and white text/image on black message field.

i NOTE

The labels shown in the owner's manual are not provided as exact reproductions of those in the car. The purpose is to show their approximate appearance and location in the car. The information that applies to your car in particular is available on the label in question in your car.

Procedure lists

Procedures where action must be taken in a certain sequence are numbered in the owner's manual.



Important information

- 1 When there is a series of illustrations for step-by-step instructions each step is numbered in the same way as the corresponding illustration.
- A There are numbered lists with letters adjacent to the series of illustrations where the order of the instructions is not significant.
- ▶ Arrows appear numbered and unnumbered and are used to illustrate a movement.

If there is no series of illustrations for step-by-step instructions then the different steps are numbered with normal numbers.

Position lists

- 1 Red circles containing a number are used in overview images where different components are pointed out. The number recurs in the position list featured in connection with the illustration that describes the item.

Bulleted lists

A bulleted list is used when there is a list of points in the owner's manual.

Example:

- Coolant
- Engine oil

To be continued

▶▶ This symbol is located furthest down to the right when a section continues on the following page.

Recording data

The driving and safety systems in the car use computers which check and share information with each other on the car's function. One or more of these computers may store information on the systems they check during normal driving, during the course of a collision or near-collision. Stored information may be used by:

- Volvo Car Corporation
- Service or repair workshops
- Police or other authorities
- Other parties who claim legal entitlement for access to the information or someone who has permission from the owner to access the information.

Accessories and extra equipment

The incorrect connection and installation of accessories can negatively affect the car's electrical system. Certain accessories only function when their associated software is installed in the car's computer system. We therefore recommend that you always contact an authorised Volvo workshop before installing accessories which are connected to or affect the electrical system.

Information on the Internet

At www.volvocars.com there is further information concerning your car.



Volvo and the environment

Volvo Cars' environmental philosophy



Environmental care is one of Volvo Car Corporation's core values which influence all operations. We also believe that our customers share our consideration for the environment.

Your Volvo complies with strict international environmental standards and is also manufactured in one of the cleanest and most resource-efficient plants in the world. Volvo Car Corporation has global ISO certification, which includes the environmental standard ISO 14001 covering all factories and several of our other units. We also set requirements for our partners so that they work systematically with environmental issues.

Fuel consumption

Volvo cars have competitive fuel consumption in each of their respective classes. Lower fuel consumption generally results in lower emission of the greenhouse gas, carbon dioxide.

It is possible for the driver to influence fuel consumption. For more information read under the heading, **Reducing environmental impact**.

Efficient emission control

Your Volvo is manufactured following the concept "Clean inside and out" – a concept that encompasses a clean interior environment as well as highly efficient emission control. In

many cases the exhaust emissions are well below the applicable standards.

Clean air in the passenger compartment

A passenger compartment filter prevents dust and pollen from entering the passenger compartment via the air intake.

A sophisticated air quality system, IAQS* (Interior Air Quality System) ensures that the incoming air is cleaner than the air in the traffic outside.

The system consists of an electronic sensor and a carbon filter. The incoming air is monitored continuously and if there is an increase in

* Option/accessory, for more information, see Introduction.



Volvo and the environment

the level of certain unhealthy gases such as carbon monoxide then the air intake is closed. Such a situation may arise in heavy traffic, queues and tunnels for example.

The entry of nitrous oxides, ground-level ozone and hydrocarbons is prevented by the carbon filter.

Textile standard

The interior of a Volvo is designed to be pleasant and comfortable, even for people with contact allergies and for asthma sufferers. Extreme attention has been given to choosing environmentally-compatible materials. This means that they also fulfil the requirements in the Oeko-Tex 100 standard¹, a major advance towards a healthier passenger compartment environment.

Oeko-Tex certification covers seatbelts, carpets and fabrics for example. The leather in the upholstery undergoes chromium-free tanning with plant substances and fulfils the certification requirements.

Volvo workshops and the environment

Regular maintenance creates the conditions for a long service life and low fuel consumption for your car. In this way you contribute to a cleaner environment. When Volvo's workshops are entrusted with the service and maintenance

of your car it becomes part of our system. We make clear demands regarding the way in which our workshops are designed in order to prevent spills and discharges into the environment. Our workshop staff have the knowledge and the tools required to guarantee good environmental care.

Reducing environmental impact

You can easily help reduce environmental impact, for example, by driving economically and by servicing and maintaining the car according to the instructions in the owner's manual.

The following advice will help you to do your bit for the environment: (for further advice on how you can reduce environmental impact and drive economically, see page 132).

- Decrease fuel consumption by choosing ECO tyre pressure, see page 176.
- A roof load and ski box increase air resistance, leading to higher fuel consumption. Remove them directly after use.
- Remove unnecessary items from the car. The greater the load the higher the fuel consumption.
- If the car is equipped with an engine block heater, always use it before starting from

cold. This reduces fuel consumption and exhaust emissions.

- Drive gently and avoid braking too hard.
- Drive in the highest gear possible. Low engine speeds result in lower fuel consumption.
- Use engine braking to slow down.
- Avoid letting the engine idle. Pay attention to local regulations. Switch off the engine when stationary for longer periods.
- Always dispose of environmentally hazardous waste, such as batteries and oils, in an environmentally safe manner. We recommend that you consult an authorised Volvo workshop for advice if you are uncertain about the disposal of this type of waste.
- Service your car regularly.
- High speed increases consumption considerably due to increased wind resistance. A doubling of speed increases wind resistance 4 times.

These hints will help reduce fuel consumption without increasing travel time or lessening the enjoyment of driving. Apart from being kind to your car, you'll be saving money - and the Earth's resources.

¹ More information on www.oekotex.com



The owner's manual and the environment

The FSC symbol shows that the paper pulp in this publication comes from FSC certified forests or other controlled sources.



Seatbelts.....	16
Airbag system.....	19
Airbags (SRS).....	20
Activating/deactivating the airbag (SRS)*.....	23
Side airbags (SIPS bags).....	25
Inflatable Curtain (IC).....	27
WHIPS.....	28
When the systems deploy.....	30
Crash mode.....	31
Child safety.....	32

SAFETY



01





Seatbelts

General information

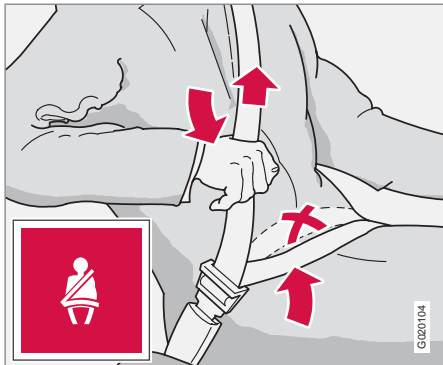

Tensioning the hip strap. The belt must be positioned low down.

Heavy braking can have serious consequences if the seatbelts are not used. Ensure that all passengers use their seatbelts. It is important that the seatbelt lies against the body so it can provide maximum protection. Do not lean the backrest too far back. The seatbelt is designed to protect in a normal seating position.

Putting on a seatbelt

- Pull the seatbelt out slowly and secure it by pressing the buckle into the lock. A loud "click" indicates that the seatbelt has locked.

Releasing the seatbelt

- Press the red lock button and then let the seatbelt retract. If the seatbelt does not retract fully, feed the seatbelt in by hand so that it does not hang loose.

The seatbelt locks and cannot be withdrawn:

- if it is pulled out too quickly.
- during braking and acceleration.
- if the car leans heavily.

Keep in mind the following:

- do not use clips or anything else that can prevent the seatbelt from fitting properly
- ensure that the seatbelt is not twisted or caught on anything
- the hip strap must be positioned low down (not over the abdomen)
- tension the hip strap over the lap by pulling the diagonal shoulder belt as illustrated.

WARNING

The seatbelts and airbags interact. If a seatbelt is not used or is used incorrectly, this may diminish the protection provided by the airbag in the event of a collision.

WARNING

Each seatbelt is designed for only one person.

WARNING

Never modify or repair the seatbelt yourself. Volvo recommends that you contact an authorised Volvo workshop. If the seatbelt has been subjected to a major load, such as in conjunction with a collision, the entire seatbelt must be replaced. Some of the seatbelt's protective properties may have been lost even if the seatbelt does not appear damaged. The seatbelt must also be replaced if it shows signs of wear or damage. The new seatbelt must be type-approved and designed for installation at the same location as the replaced seatbelt.

WARNING

The rear seat is designed for a maximum of two passengers.



Seatbelts

Seatbelts and pregnancy



The seatbelt should always be worn during pregnancy. But it is crucial that it be worn in the correct way. The diagonal section of the seatbelt should wrap over the shoulder then be routed between the breasts and to the side of the abdomen. The lap section of the seatbelt should lay flat over the thighs and as low as possible under the abdomen. – It must never be allowed to ride upward. Remove all slack from the seatbelt and ensure that it fits close to the body. In addition, check that there are no twists in the seatbelt.

As a pregnancy progresses, pregnant drivers should adjust their seats and steering wheel such that they can easily maintain control of the

vehicle as they drive (which means that they must be able to easily operate the foot pedals and steering wheel). They should strive to position the seat with as large a distance as possible between their abdomen and the steering wheel.

Seatbelt reminder



Unbelted occupants will be reminded to fasten their seatbelts by means of an audio and visual reminder. The audio reminder is speed dependent, and in some cases time dependent. The visual reminder is located in the roof console and the combined instrument panel.

Child seats are not covered by the seatbelt reminder system.

Rear seat

The seatbelt reminder in the rear seat has two subfunctions:

- Provides information on which seatbelts are being used in the rear seat. A message is shown in the information display when the seatbelts are used. The message is automatically cleared after approx. 30 seconds or can be acknowledged manually by pressing the **READ** button.
- Provides a warning if one of the rear seatbelts is unfastened during a journey. This warning takes the form of a message on the information display along with the audio/visual signal. The warning ceases when the seatbelt is re-fastened or when acknowledged manually by pressing the **READ** button.

The message on the information display showing which seatbelts are in use is always available. Press the **READ** button to see stored messages.

Certain markets

An audio signal and indicator lamp remind the driver if not wearing a seatbelt to use one. At low speed, the audio reminder will sound for the first six seconds.



Seatbelts

Seatbelt tensioner

All the seatbelts are equipped with seatbelt tensioners. A mechanism in the seatbelt tensioner tightens the seatbelt in the event of a sufficiently violent collision. The seatbelt then provides more effective restraint for occupants.

Seatbelt guide

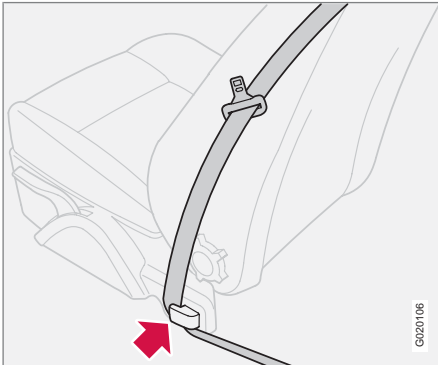

The seatbelt guide is fitted on both the driver's seat and passenger seat.

The seatbelt guide is an aid for providing better access to the seatbelt. When getting into and out of the rear seat, remove the seatbelt from the seatbelt guide and position it furthest back

on the seatbelt bar. Refit the seatbelt into the seatbelt guide afterwards.



Airbag system

01

Warning symbol on the combined instrument panel

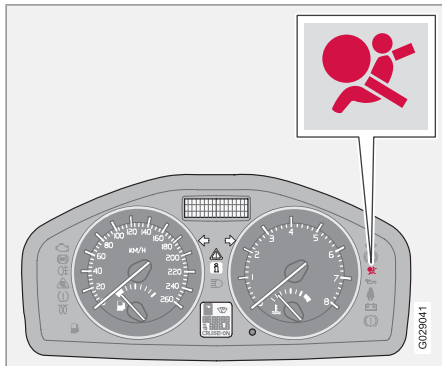

The airbag system¹ is continually monitored by the system's control module. The warning symbol in the combined instrument panel illuminates when the remote control key is turned to position **I**, **II** or **III**. The symbol goes out after approx. 6 seconds provided the airbag system¹ is working correctly.



As well as the warning symbol, a message may appear on the display in appropriate cases. If the warning symbol malfunctions, the warning triangle illuminates and the message **SRS AIRBAG SERVICE REQUIRED** or **SRS AIRBAG SERVICE URGENT** appears in the display. Volvo recommends that you contact an authorised Volvo workshop immediately.



WARNING

If the warning symbol for the airbag system remains illuminated or illuminates while driving, it means that the airbag system does not have full functionality. The symbol indicates a fault in the seatbelt tensioner system, SIPS, SRS or the IC system. Volvo recommends that you contact an authorised Volvo workshop immediately.

¹ Includes SRS and seatbelt tensioner, SIPS and IC.



Airbags (SRS)

Airbag system

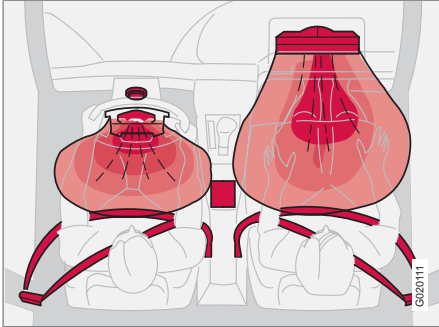

SRS system, left-hand drive

The system consists of airbags and sensors. A sufficiently violent collision trips the sensors and the airbag(s) are inflated with hot gas. To cushion the impact, the airbag deflates when compressed. When this occurs, smoke escapes into the car. This is completely normal. The entire process, including inflation and deflation of the airbag, takes place within tenths of a second.

WARNING

Volvo recommends that you contact an authorised Volvo workshop for repair. Defective work in the airbag system could cause malfunction and result in serious personal injury.

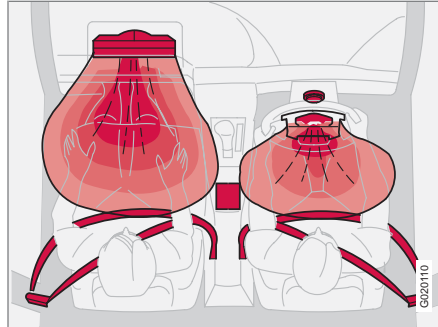

SRS system, right-hand drive

NOTE

The sensors react differently depending on the course of the collision and whether or not the seatbelts on the driver's side and passenger side are used.

It is therefore possible that only one (or none) of the airbags may inflate in a collision. The airbag system senses the force of the collision on the car and adapts accordingly so that one or more airbags is deployed.

The capacities of the airbags are also adapted to the collision force to which they are subjected.



Airbags (SRS)

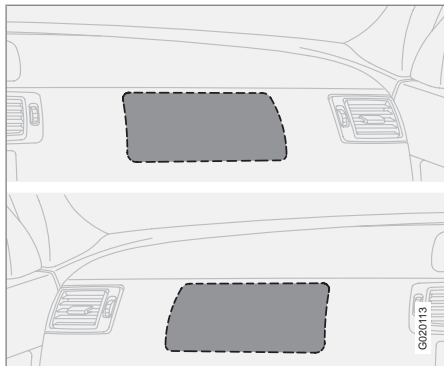

Location of the passenger airbag in left-hand drive and right-hand drive cars.

WARNING

Do not put objects in front of or above the instrument panel where the passenger airbag is located.

Airbag (SRS) on the driver's side

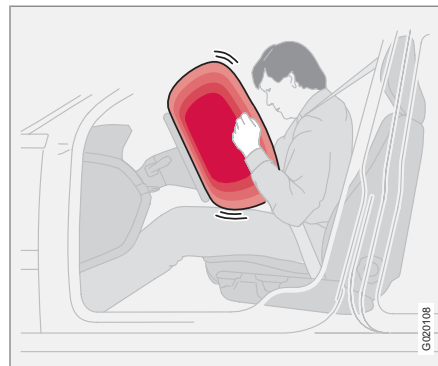

The car has an SRS airbag (Supplemental Restraint System) to supplement the protection afforded by the seatbelt on the driver's side. This airbag is fitted into the centre of the steering wheel. The steering wheel is marked **SRS AIRBAG**.

WARNING

The seatbelts and airbags interact. If a seatbelt is not used or is used incorrectly, this may diminish the protection provided by the airbag in the event of a collision.

Passenger airbag (SRS)

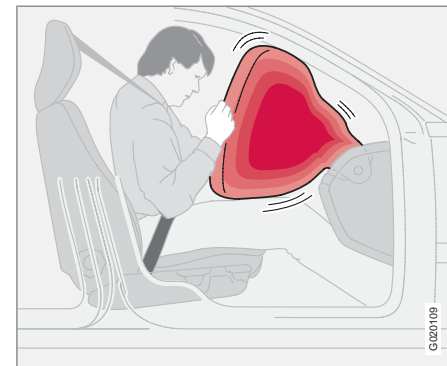

The car has an airbag¹ to supplement the protection afforded by the seatbelt on the passenger side. This airbag is folded up into a compartment above the glovebox. Its cover panel is marked **SRS AIRBAG**.

WARNING

To minimise the risk of injury if the airbag deploys, passengers must sit as upright as possible with their feet on the floor and back against the backrest. Seatbelts must be secured.

¹ Not all cars have a passenger airbag (SRS). This can be unselected when the car is ordered.



01 Safety

01

Airbags (SRS)

WARNING

Never place a child in a child seat or on a booster cushion in the front seat if the airbag (SRS) is activated.²

Never allow a child to stand or sit in front of the front passenger seat. Children under 140 cm must never sit in the front passenger seat if the airbag (SRS) is activated.

Failure to follow the advice given above can endanger the life of the child.

Label Airbag

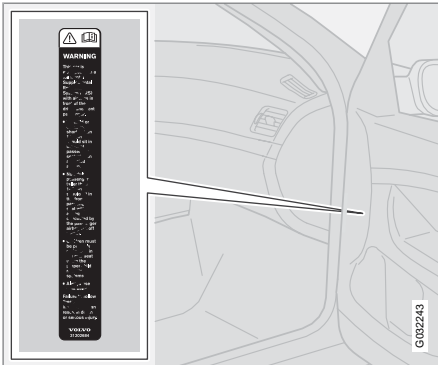

Location of decal for front passenger airbag.

² For information on activated/deactivated airbag (SRS), see page 23.



Activating/deactivating the airbag (SRS)*

Key switch off - PACOS

General information

The airbag (SRS) for the front passenger seat can be deactivated if the car is equipped with a PACOS switch. For information on how to activate/deactivate, see under the heading Activating/deactivating.

Key switch off/switch

The switch for the passenger airbag (PACOS) is located on the passenger end of the instrument panel and is accessible when the passenger door is open, (see under the heading, Switch – PACOS). Check that the switch is in the required position. Volvo recommends that the key blade is used to change position.

For information on the key blade, see page 117.

WARNING

Failure to follow the advice given above can endanger life.

WARNING

If the car is equipped with a front passenger airbag (SRS), but does not have a switch (PACOS), the airbag will always be activated.

WARNING

Never place a child in a child seat or on a booster cushion in the front seat if the airbag is activated and the symbol  in the roof console is illuminated. Failure to follow this advice could endanger the life of the child.

WARNING

Do not allow anyone to sit in the front passenger seat if the text message in the roof panel indicates that the airbag (SRS) is deactivated and if the warning symbol for the airbag system is also displayed on the combined instrument panel. This indicates that there has been a severe malfunction. Volvo recommends that you visit an authorised Volvo workshop as soon as possible.

Activating/deactivating

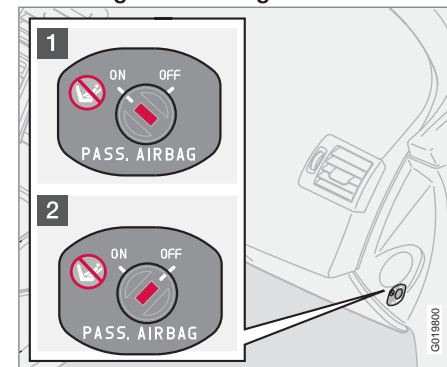

Switch location.

- 1** The airbag is activated. With the switch in this position, children taller than 140 cm can sit in the front passenger seat, but never children in a child seat or on a booster cushion.
- 2** The airbag is deactivated. With the switch in this position, children in a child seat or on a booster cushion can sit in the front passenger seat, but never persons taller than 140 cm.



Activating/deactivating the airbag (SRS)*

! WARNING

Activated airbag (passenger seat):

Never place a child who is shorter than 140 cm in a child seat or on a booster cushion on the front passenger seat when the airbag is activated.

Deactivated airbag (passenger seat):

Children taller than 140 cm must never sit in the front passenger seat when the airbag is deactivated.

Failure to follow the advice given above can endanger life.

Messages

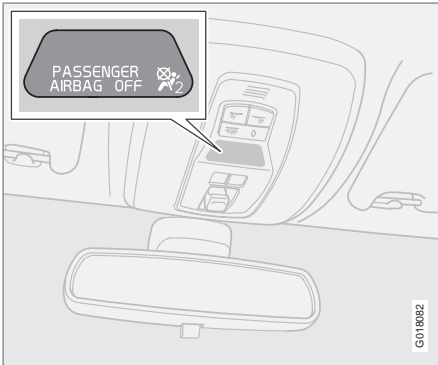

Indicator showing that the passenger airbag (SRS) is deactivated.

A text message and a symbol in the roof panel indicate that the airbag (SRS) for the front passenger seat is deactivated (see preceding illustration).

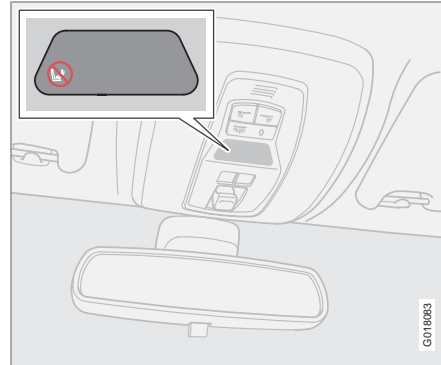

Indicator showing that the passenger airbag (SRS) is activated.

A warning symbol in the roof panel indicates that the airbag (SRS) for the front passenger seat is activated (see preceding illustration).

i NOTE

When the remote control key is turned to ignition position **II** or **III** the warning symbol for the airbag is shown in the combined instrument panel for approx. 6 seconds, see page 19.

Following which, the indicator in the roof console is illuminated showing the correct status for the front passenger seat airbag. For more information on the different ignition positions, see page 135.



Side airbags (SIPS bags)

Side airbag



Side airbag locations.

In a side impact collision a large proportion of the collision force is transferred by the SIPS (Side Impact Protection System) to beams, pillars, the floor, the roof and other structural parts of the body. The side airbags at the driver's and front passenger seats protect the chest area and are an important part of the SIPS. The side airbags are located in the front seat backrests.

WARNING

- Volvo recommends that repairs are only carried out by an authorised Volvo workshop. Defective work in the SIPS-bag system could cause malfunction and result in serious personal injury.
- Do not place any objects in the area between the outside of the seat and the door panel, since this area is required by the side airbag.
- Volvo recommends the use only of car seat covers approved by Volvo. Other seat covers may impede the operation of the side airbags.
- Side airbags are a supplement the seatbelts. Always use a seatbelt.

Child seats and side airbags

The protection provided by the car to children seated in a child seat or on a booster cushion is not diminished by the side airbag.

A child seat or booster cushion can be placed on the front passenger seat provided that the car does not have an activated¹ passenger airbag.

Location

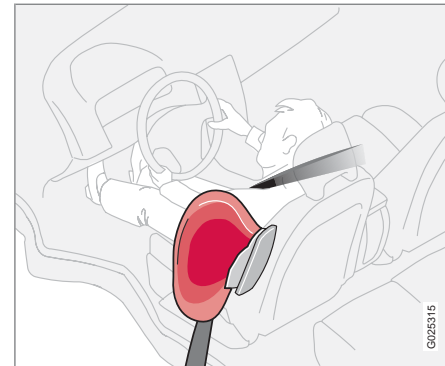

Driver's seat, left-hand drive.

¹ For information on activated/deactivated airbag (SRS), see page 23.



Side airbags (SIPS bags)

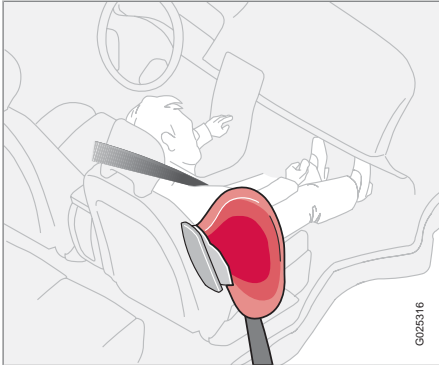

Front passenger seat, left-hand drive.

The SIPS bag system consists of side airbags and sensors. A sufficiently violent collision trips the sensors and the side airbags are inflated. The airbag inflates between the occupant and the door panel and thereby cushions the initial impact. The airbag deflates when compressed by the collision. The side airbag is normally only deployed on the side of the collision.

Label, side airbag

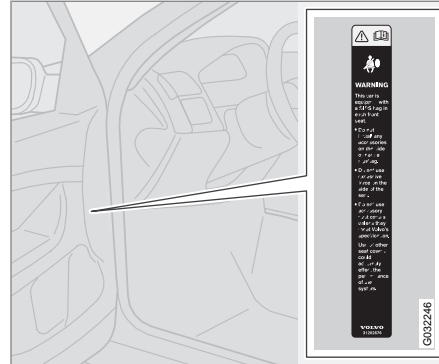

Location of decal for side airbag, driver's side, front, left-hand drive car.



Inflatable Curtain (IC)

Properties

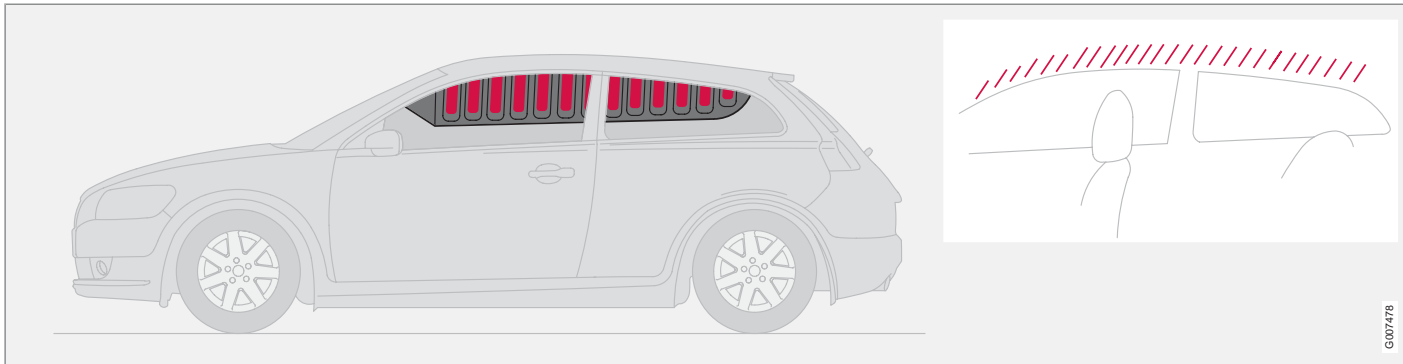

G007478

The inflatable curtain IC (Inflatable Curtain) is a supplement to the SIPS and the airbags. It is fitted in the headlining along both sides of the roof and protects the car's occupants sitting in the outer seats. A sufficiently violent collision trips the sensors and the inflatable curtain is inflated. The inflatable curtain helps to prevent the driver and passengers from striking their heads on the inside of the car during a collision.

WARNING

Never hang or attach heavy items onto the handles in the roof. The hook is only designed for light clothing (not for solid objects such as umbrellas for example).

Do not screw or install anything onto the car's headlining, door pillars or side panels. This could compromise the intended protection. Volvo recommends that you only ever use Volvo genuine parts that are approved for placement in these areas.

WARNING

Do not load the car higher than 50 mm under the top edge of the side windows. Otherwise, the intended protection of the inflatable curtain, which is concealed in the headlining, may be compromised.

WARNING

The inflatable curtain is a supplement to the seatbelts.
Always use a seatbelt.



WHIPS

Protection against whiplash injury – WHIPS

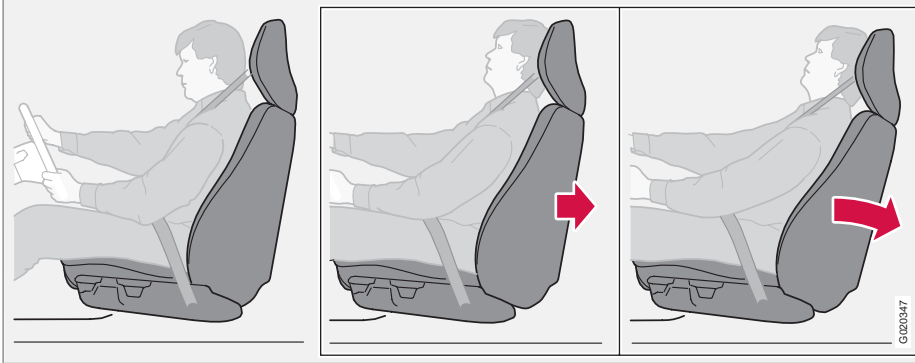

The whiplash protection system (WHIPS) consists of energy absorbing backrests and specially designed head restraints for the front seats. The system is actuated by a rear-end collision, where the angle and speed of the collision, and the nature of the colliding vehicle all have an influence.

WARNING

The WHIPS system is a supplement to the seatbelts. Always use a seatbelt.

Properties of the seat

When the WHIPS system is deployed, the front seat backrests are lowered backward to alter the seating position of the driver and front seat passenger. This reduces the risk of whiplash injury.

WARNING

Never modify or repair the seat or WHIPS system yourself. Volvo recommends that you contact an authorised Volvo workshop.

WHIPS system and child seats/booster cushions

The protection provided by the car to children seated in a child seat or on a booster cushion is not diminished by the WHIPS system.

Correct seating position

For the best possible protection, the driver and front seat passenger should sit in the centre of the seat with as little space as possible between the head and the head restraint.



WHIPS

Do not obstruct the WHIPS system



Do not leave any objects on the floor behind the driver's seat or the passenger seat.

 **WARNING**

Do not squeeze rigid objects between the rear seat cushion and the front seat backrest. Make sure you do not obstruct the function of the WHIPS system.



Do not leave any objects on the rear seat.

 **WARNING**

If a rear seat backrest is folded down, the corresponding front seat must be moved forward so that it does not touch the folded backrest.

 **WARNING**

If a seat has been subjected to extreme forces, such as due to a rear-end collision, the WHIPS system must be checked. Volvo recommends that it is checked by an authorised Volvo workshop.

Part of the WHIPS system's protective capacity may have been lost even if the seats appear to be undamaged.

Volvo recommends that you contact an authorised Volvo workshop to have the system checked even after a minor rear-end collision.



When the systems deploy

Activating the systems

System	Triggered
Seatbelt tensioner, front seat	In a frontal collision and/or side-impact accident and/or rear-end collision
Seatbelt tensioner, outside rear seat	In a frontal collision
Airbags (SRS)	In a frontal collision ^A
Side airbags (SIPS)	In a side-impact accident ^A
Inflatable Curtain IC	In a side-impact accident ^A
Whiplash protection WHIPS	In a rear-end collision

^A The bodywork of the car could be greatly deformed in a collision without airbag deployment. A number of factors such as the rigidity and weight of the object hit, the speed of the car, the angle of the collision etc. affects how the different safety systems of the car are activated.

If the airbags have been deployed, the following is recommended:

- Recovering the car. Volvo recommends that you have it conveyed to an authorised Volvo workshop. Do not drive with deployed airbags.
- Volvo recommends that you engage an authorised Volvo workshop to handle the replacement of components in the car's safety systems.
- Always contact a doctor.



NOTE

The SRS, SIPS, IC and belt tensioner systems are deployed only once during a collision.



WARNING

The airbag control module is located in the centre console. If the centre console is drenched with water or other liquid, disconnect the battery cables. Do not attempt to start the car since the airbags may deploy. Recovering the car. Volvo recommends that you have it conveyed to an authorised Volvo workshop.



WARNING

Never drive with deployed airbags. They can make steering difficult. Other safety systems may also be damaged. The smoke and dust created when the airbags are deployed can cause skin and eye irritation/injury after intensive exposure. In case of irritation, wash with cold water. The rapid deployment sequence and airbag fabric may cause friction and skin burns.



Crash mode

Driving after a collision

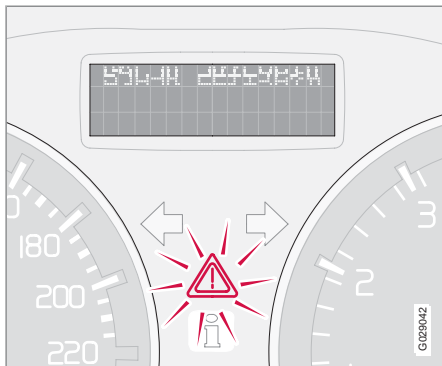

If the car is involved in a collision, the text **CRASH MODE SEE MANUAL** may appear on the information display. This means that the car has reduced functionality. Crash mode is a protective state that is enforced when the collision may have damaged any of the car's vital functions, such as the fuel lines, sensors for one of the safety systems, or the brake system.

Attempting to start the car

First, check that no fuel is leaking from the car. There must be no smell of fuel either.

If everything seems normal and you have checked for indications of fuel leakage, you may attempt to start the car.

Firstly, remove the remote control key and then reinsert it. The car's electronics will then try to reset themselves to normal mode. Then try to start the car. If **CRASH MODE SEE MANUAL** is still shown on the display then the car must not be driven or towed. Even if the car appears to be driveable, hidden damage may make the car impossible to control once moving.

Moving the car

If **NORMAL MODE** is shown after **CRASH MODE SEE MANUAL** has been reset, the car can be moved carefully out of a dangerous position. Do not move the car further than necessary.

 **WARNING**

Never attempt to repair your car or reset the electronics yourself if the car has been in crash mode. This could result in personal injury or the car not functioning as normal. Volvo recommends that you always engage an authorised Volvo workshop to check and restore the car to **NORMAL MODE** after **CRASH MODE SEE MANUAL** has been displayed.

 **WARNING**

Never, under any circumstances, attempt to restart the car if it smells of fuel when the **CRASH MODE SEE MANUAL** message is displayed. Leave the car at once.

 **WARNING**

If the car is in crash mode it must not be towed. It must be transported from its location. Volvo recommends that you have it conveyed to an authorised Volvo workshop.



Child safety

Children should sit comfortably and safely

The position of a child in the car and the choice of equipment are dictated by the child's weight and size. For more information, see page 33.

i NOTE

Regulations regarding the placement of children in cars vary from country to country. Check what does apply.

Children of all ages and sizes must always sit correctly secured in the car. Never allow a child to sit on the knee of a passenger.

Volvo's own child safety equipment is designed for your car. Volvo recommends that you use Volvo genuine equipment to best ensure that the mounting points and attachments are correctly positioned and are sufficiently strong.

i NOTE

In the event of questions when fitting child safety products, contact the manufacturer for clearer instructions.

Child seats

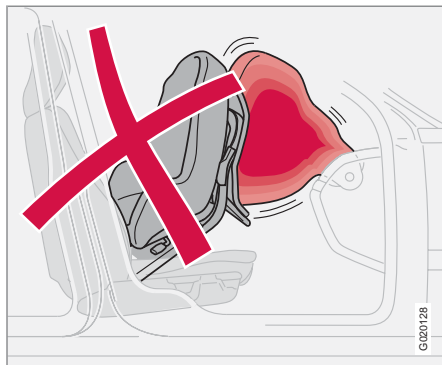

Child seats and airbags are not compatible.

Volvo has child safety products that are designed for and tested by Volvo.

i NOTE

When using child safety products it is important to read the installation instructions included with the product.

Do not attach the straps for the child seat to the horizontal adjustment bar, springs, rails or

beams under the seat. Sharp edges can damage the straps.

Look in the installation instructions for the child seat for the correct fitting.

Location of child seats

You may place:

- a child seat/booster cushion on the front passenger seat, provided the passenger airbag is not activated¹.
- a rear-facing child seat in the rear seat.

Always place a child in the rear seat if the passenger airbag is activated. A child in the front passenger seat could suffer serious injury if the airbag deploys.

! WARNING

Never place a child in a child seat or on a booster cushion in the front seat if the airbag (SRS) is activated².

Children shorter than 140 cm must never sit in the front passenger seat if the airbag (SRS) is activated.

Failure to follow the advice given above can endanger the life of the child.

¹ For information on activated/deactivated airbag (SRS), see page 23.

² For information on activating/deactivating the airbag (SRS), see page 23.

**! WARNING**

Booster cushions/child seats with steel braces or some other design that could rest on the seatbelt buckle's opening button must not be used, as they could cause the seatbelt buckle to open accidentally.

Do not allow the upper section of the child seat to rest against the windscreen.

Label Airbag

Label located on instrument panel end face.

Recommended child seats³

Weight/age	Front seat ^A	Rear seat
Group 0 max. 10 kg (0 – 9 months)	Volvo Child seat – rear-facing child seat, secured with the car's seatbelt and straps. Use a protective cushion between the child seat and the dashboard. Type approval: E5 03135	Volvo Child seat – rear-facing child seat, secured with the car's seatbelt, straps and support legs. ^B Type approval: E5 03135
Group 0+ max. 13 kg	Volvo infant seat - rear-facing child seat, secured with the ISOFIX fixture system. Type approval: E1 03301146	Volvo infant seat - rear-facing child seat, secured with the ISOFIX fixture system. Type approval: E1 03301146
	Volvo infant seat – rear-facing child seat, secured with the car's seatbelt Type approval: E1 03301146	Volvo infant seat – rear-facing child seat, secured with the car's seatbelt Type approval: E1 03301146

³ With regard to other child seats the car should be included in the manufacturer's enclosed list of vehicles or be universally approved in accordance with the ECE R44 legal requirement.



01 Safety

01

Child safety

Weight/age	Front seat ^A	Rear seat
Group 1 9 – 18 kg (9 – 36 months)	Volvo Child seat – rear-facing child seat, secured with the car's seatbelt and straps. Use a protective cushion between the child seat and the dashboard. Type approval: E5 03135	Volvo Child seat – rear-facing child seat, secured with the car's seatbelt, straps and support legs. ^B Type approval: E5 03135
	Volvo turnable child seat – rear-facing child seat, secured with the car's seatbelt and straps. Type approval: E5 04192	Volvo turnable child seat – rear-facing child seat, secured with the car's seatbelt and straps. Type approval: E5 04192
	Britax Fixway – rear-facing child seat, secured with the ISOFIX fixture system and straps. Type approval: E5 03171	Britax Fixway – rear-facing child seat, secured with the ISOFIX fixture system and straps. ^B Type approval: E5 03171
Group 2, 15-25 kg, 3-6 yr	Volvo turnable child seat - front-facing child seat, secured with the car's seatbelt. Type approval: E5 04191	Volvo turnable child seat - front-facing child seat, secured with the car's seatbelt. Type approval: E5 04191
	Volvo turnable child seat – rear-facing child seat, secured with the car's seatbelt and straps Type approval: E5 04192	Volvo turnable child seat – rear-facing child seat, secured with the car's seatbelt and straps Type approval: E5 04192



Child safety

Weight/age	Front seat ^A	Rear seat
Group 2/3 15 – 36 kg (3 – 12 years)	Volvo Booster cushion – with or without backrest. Type approval: E5 03139	Volvo Booster cushion – with or without backrest. Type approval: E5 03139
	Volvo booster cushion with backrest. Type approval: E1 04301198	Volvo booster cushion with backrest. Type approval: E1 04301198

^A For information on activated/deactivated airbag (SRS), see page 23.

^B To install a rear-facing child seat in the rear seat, Volvo recommends that you contact an authorised Volvo dealer to have the mounting points installed.

WARNING

Never place a child in a child seat or on a booster cushion in the front seat if the airbag (SRS) is activated⁴.

Children shorter than 140 cm must never sit in the front passenger seat if the airbag (SRS) is activated.

Failure to follow the advice given above can endanger the life of the child.

ISOFIX fixture system for child seats*



Mounting points for the ISOFIX fixture system are concealed behind the lower section of the rear seat backrest, in the outer seats.

The location of the mounting points is indicated by symbols in the backrest upholstery (see illustration above).

Press the seat cushion down to access the mounting points.

Always follow the manufacturer's installation instructions when connecting a child seat to the ISOFIX mounting points.

⁴ For information on activating/deactivating the airbag (SRS), see page 23.



Child safety

Mounting points for child seats

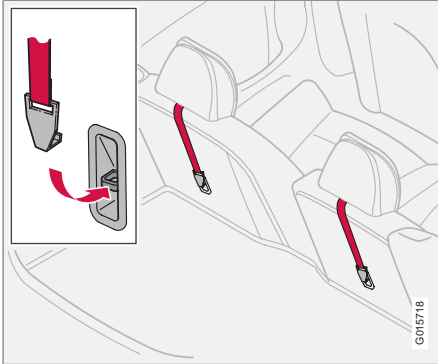

The car is equipped with upper mounting points for child seats. These mounting points are located on the rear side of the rear seat.

The child seat's straps must be routed between the head restraint and the backrest.

For detailed information on how to secure the child seat in the upper mounting points, refer to the instructions from the child seat manufacturer.



[Empty rectangular box]

01

Overview, left-hand drive cars.....	40
Overview, right-hand drive cars.....	42
Driver's door control panel.....	44
Combined instrument panel.....	45
Indicator and warning symbols.....	46
Information display.....	50
Electrical socket.....	52
Lighting panel.....	53
Left-hand stalk switch.....	55
Right-hand stalk switch.....	58
Cruise control*.....	61
Keypad in the steering wheel*.....	63
Steering wheel adjustment, hazard warning flashers.....	64
Parking brake.....	65
Power windows.....	66
Windows, rearview and door mirrors.....	68
Power sunroof*.....	72
Personal preferences.....	74
HomeLink® *.....	76

INSTRUMENTS AND CONTROLS



02



02 Instruments and controls

Overview, left-hand drive cars

02

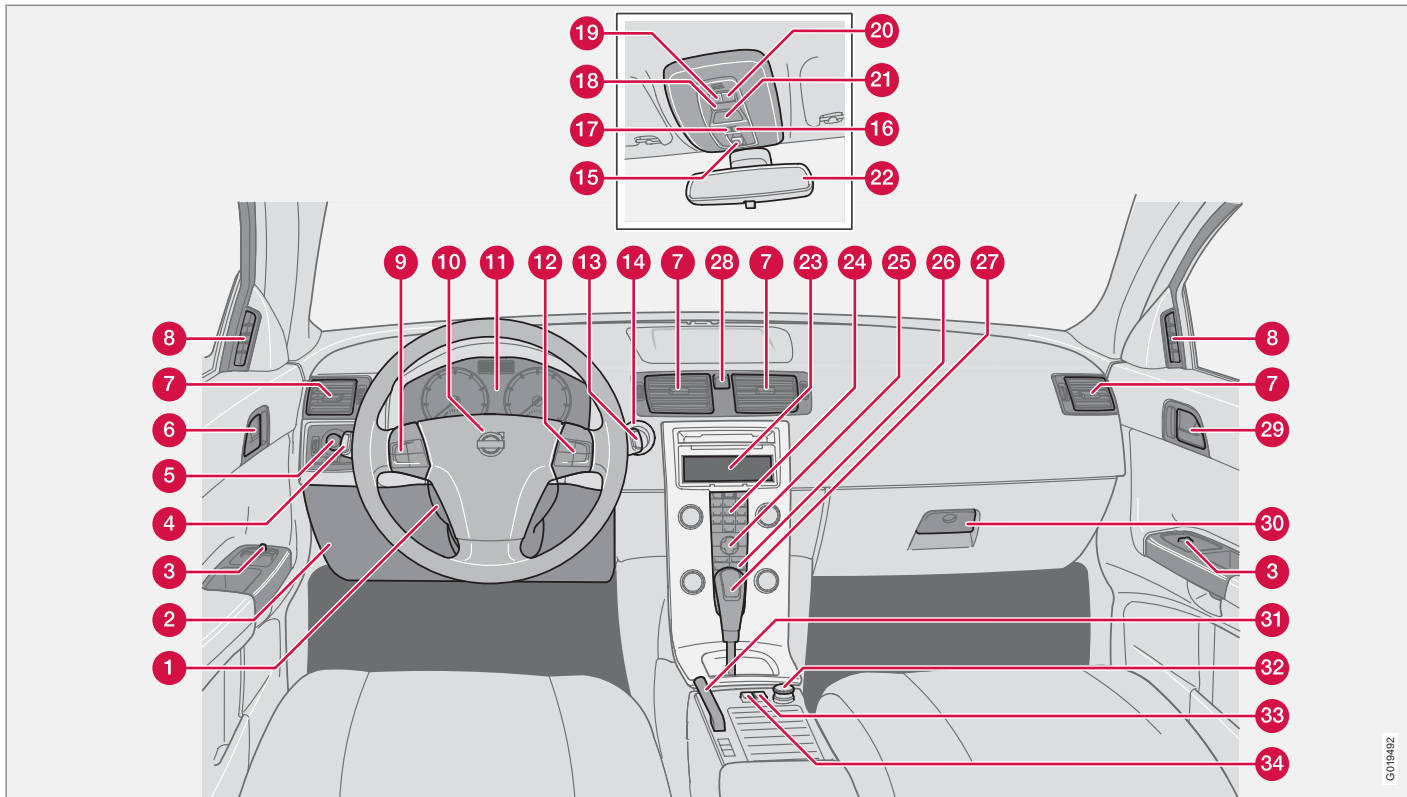

G015492



Overview, left-hand drive cars

- 1 Steering wheel adjustment
- 2 Bonnet release
- 3 Control panel
- 4 Direction indicators, main beam, trip computer
- 5 Lighting, fuel filler flap opener
- 6 Door handle, lock button.
- 7 Air vents in dashboard
- 8 Air vent for side window
- 9 Cruise control
- 10 Horn, airbag
- 11 Combined instrument panel
- 12 Keypad for infotainment system
- 13 Windscreen wipers and washer, headlamp washers
- 14 Ignition switch
- 15 Sunroof controls
- 16 No function
- 17 No function
- 18 Switch for interior lighting
- 19 Reading lamp, left-hand side
- 20 Reading lamp, right-hand side
- 21 Seatbelt reminder and passenger seat airbag indicator
- 22 Interior rearview mirror
- 23 Display for climate control and infotainment system
- 24 Infotainment system
- 25 Controls for climate control, infotainment system and personal preferences
- 26 Climate control
- 27 Gear lever
- 28 Hazard warning flashers
- 29 Door handle
- 30 Glovebox
- 31 Parking brake
- 32 Electrical socket/cigarette lighter
- 33 Blind Spot Information System, BLIS
- 34 Switch, optional equipment



Overview, right-hand drive cars

02

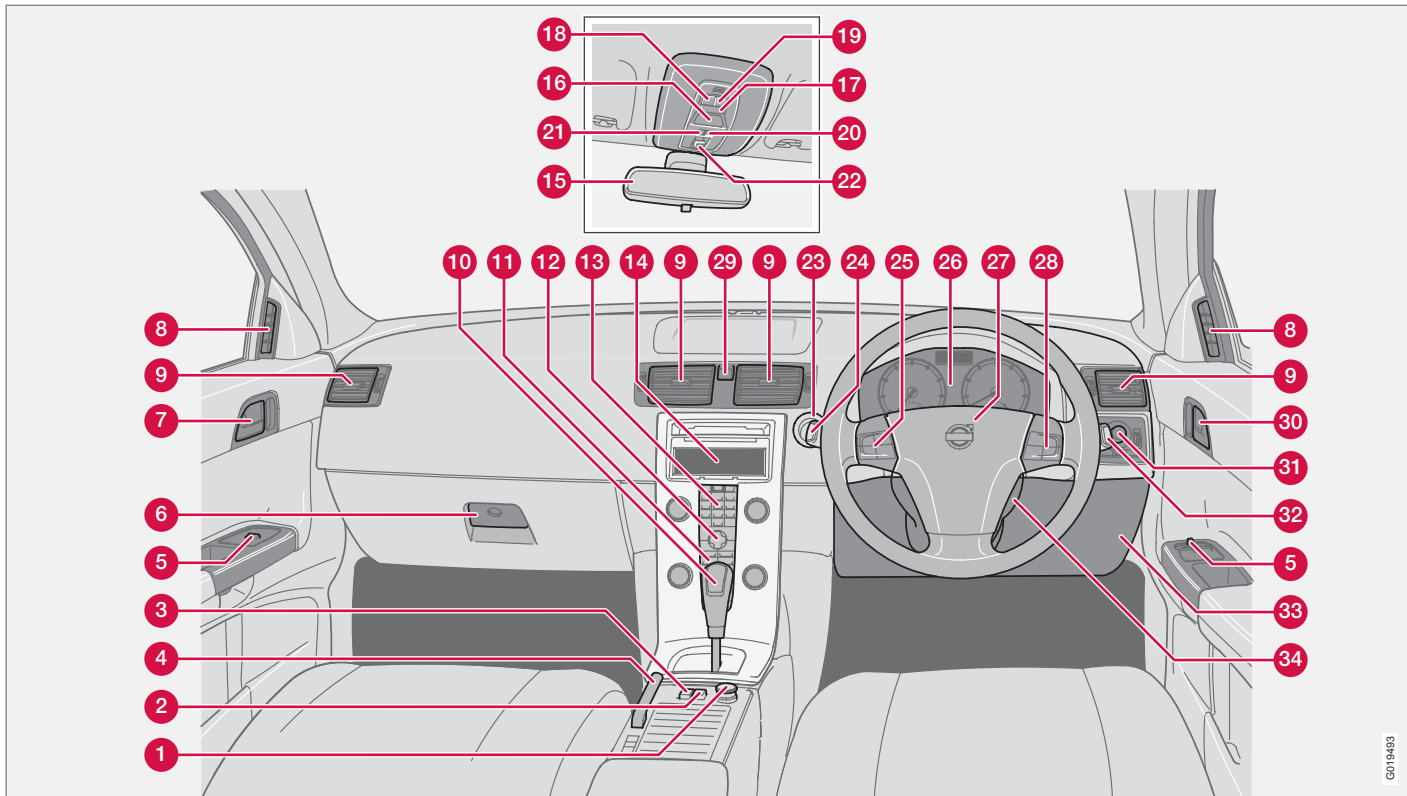

G015483



Overview, right-hand drive cars

- 1 Electrical socket, cigarette lighter
- 2 Blind Spot Information System, BLIS
- 3 Switch, optional equipment
- 4 Parking brake
- 5 Control panel
- 6 Glovebox
- 7 Door handle
- 8 Air vent for side window
- 9 Air vents in dashboard
- 10 Gear lever
- 11 Climate control
- 12 Controls for climate control, infotainment system and personal preferences
- 13 Infotainment system
- 14 Display for climate control and infotainment system
- 15 Interior rearview mirror
- 16 Seatbelt reminder and passenger seat air-bag indicator
- 17 Switch for interior lighting
- 18 Reading lamp, left-hand side
- 19 Reading lamp, right-hand side
- 20 No function
- 21 No function
- 22 Sunroof controls
- 23 Ignition switch
- 24 Windscreen wipers and washers, head-lamp washers
- 25 Cruise control
- 26 Combined instrument panel
- 27 Horn, airbag
- 28 Keypad for infotainment system
- 29 Hazard warning flashers
- 30 Door handle, lock button
- 31 Lighting, fuel filler flap opener
- 32 Direction indicators, main beam, trip computer
- 33 Bonnet release
- 34 Steering wheel adjustment



Driver's door control panel

Driver's door control panel

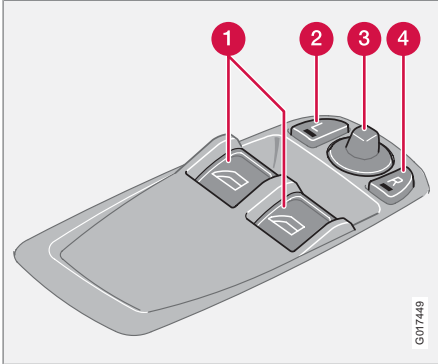

- 1 Power windows
- 2 Door mirror, left-hand side
- 3 Door mirrors, setting
- 4 Door mirror, right-hand side



Combined instrument panel

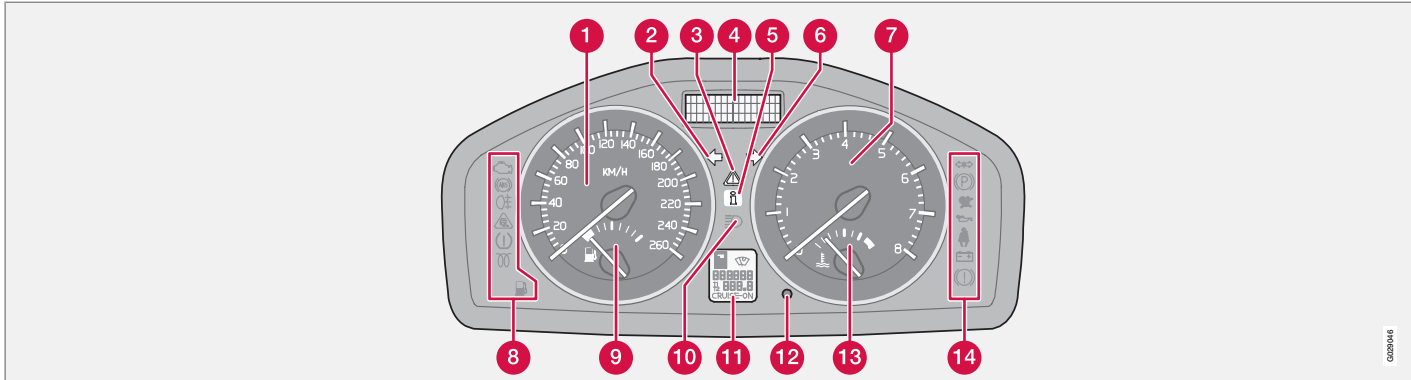

- 1** Speedometer.
- 2** Direction indicators, left.
- 3** Warning symbol.
- 4** Information display – Shows information or warning messages, outside temperature and clock. When the outside temperature is between +2 °C to -5 °C a snowflake illuminates on the display. This warns of icy roads. The outside temperature gauge may show a slightly high reading after the car has been stationary.
- 5** Information symbol.
- 6** Direction indicator, right.
- 7** Tachometer – Indicates engine speed in thousands of revolutions per minute (rpm).
- 8** Indicator and warning symbols.
- 9** Fuel gauge, see also trip computer, page 56.
- 10** Main beam indicator.
- 11** Display – Display for automatic gear position, rain sensor, odometer, trip meter and cruise control.
Also shows gear shift indicator (GSI) and gear positions in the 1.6D DRIVE model, see page 140.
- 12** Button for trip meter – Used to measure short distances. Short presses on the button switches between the two trip meters T1 and T2. A long press (more than 2 seconds) resets an active trip meter to zero.
- 13** Temperature gauge - Used for the engine cooling system. A message will appear on the display if the temperature becomes too high and the gauge goes into the red zone. Bear in mind that extra lights placed in front of the air intake, for example, reduce the cooling capacity at high outside temperatures and high engine loads.
- 14** Indicator and warning symbols.

Indicator and warning symbols

Functionality check, symbols

All indicator and warning symbols¹ illuminate when the remote control key is turned to position **II** before starting. This is to check that the symbols are working. When the engine starts, all the symbols should go out except the hand-brake symbol, which only goes out when the brake is disengaged.

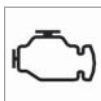

If the engine does not start within five seconds, all symbols extinguish except the symbols for a fault in the car's emissions system and for low oil pressure. Certain symbols may have no function, depending on the car's specifications.



Symbols in the centre of the instrument panel

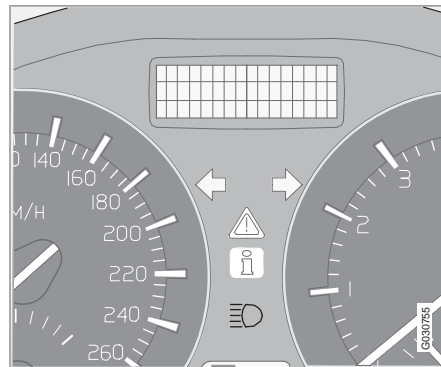

The red warning symbol illuminates when a fault has been indicated which could affect the safety and/or driveability of the car. An explanatory text is shown on the information display at the same time. The symbol remains visible until the fault has been rectified but the text message can be cleared with the **READ** button, see page 50. The warning symbol can also illuminate in conjunction with other symbols.

When the symbol illuminates:

1. Stop in a safe manner. Do not drive the car further.
2. Read the information on the information display. Implement the action in accordance with the message in the display. Clear the message using **READ**.



The yellow information symbol illuminates and a text appears on the information display. The message text is cleared using the **READ** button, see page 50, or disappears automatically after a period of time (time depending on which function is indicated). The yellow information symbol can also illuminate in conjunction with other symbols.



NOTE

When a service message is shown, the symbol and message are cleared using the **READ** button, or disappear automatically after a time.

¹ For certain engine variants, the symbol for low oil pressure is not used. Warnings are given via display text, see page 50.



Indicator and warning symbols

Indicator symbols – left-hand side

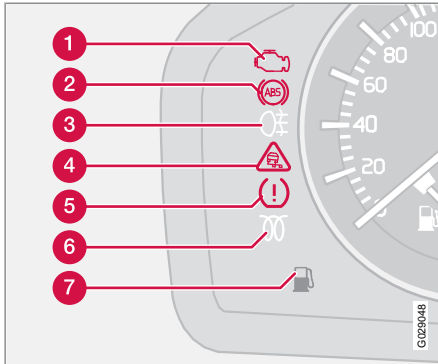

- 1 Fault in car's emissions system
- 2 ABS fault
- 3 Rear fog lamp
- 4 Stability system STC or DSTC
- 5 No function
- 6 Engine preheater (diesel)
- 7 Low level in fuel tank

Emissions system

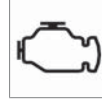

If the symbol illuminates then it may be due to a fault in the car's emissions system. Volvo recommends that you seek assistance from an authorised Volvo workshop for inspection.

ABS fault



If this symbol illuminates then the system is not working. The car's regular brake system continues to work, but without the ABS function.

1. Stop the car in a safe place and turn off the engine.
2. Restart the engine.
3. Drive to a workshop to have the ABS system checked if the symbol remains lit. Volvo recommends that you seek assistance from an authorised Volvo workshop.

Rear fog lamp



This symbol is lit when the rear fog lamp is on.

Stability system STC or DSTC*



For information on the system's functions and symbols, see page 148.

Engine preheater (diesel)



This symbol illuminates during engine preheating. Preheating occurs when the temperature is below -2°C . The car can be started once the symbol goes out.

Low level in fuel tank



When the symbol illuminates the level in the fuel tank is low, refuel as soon as possible.

Indicator and warning symbols

Indicator symbols – right-hand side

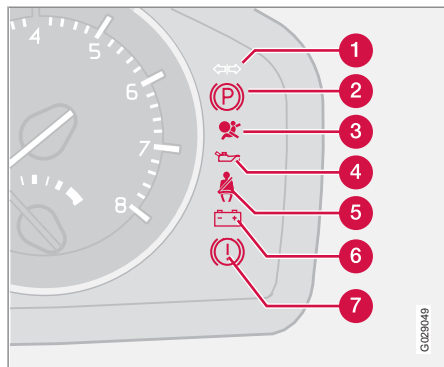

G 0230049

- 1 Indicator symbol for trailer
- 2 Parking brake applied
- 3 Airbags – SRS
- 4 Low oil pressure
- 5 Seatbelt reminder
- 6 Alternator not charging
- 7 Fault in brake system

Indicator symbol for trailer



This symbol flashes when the direction indicators are used and the trailer is connected. If the symbol does not flash then one of the lamps on the trailer or the car is

faulty.

Parking brake applied



The symbol illuminates when the parking brake is applied. Always pull the parking brake lever to the end position.

NOTE

The symbol illuminates irrespective of how hard the parking brake is applied.

Airbags – SRS



If this symbol remains illuminated or illuminates while driving, it means a fault has been detected in the seatbelt buckle, SRS, SIPS or IC system. Volvo recommends that drive directly to an authorised Volvo workshop for inspection.

Low oil pressure²



If this symbol illuminates during driving then the engine's oil pressure is too low. Stop the engine immediately and check the engine oil level, top up if necessary. If the

symbol illuminates and the oil level is normal Volvo recommends that you contact an authorised Volvo workshop.

Seatbelt reminder



This symbol illuminates if someone in a front seat has not put on their seatbelt or if someone in a rear seat has taken off their seatbelt.

Alternator not charging



If this symbol illuminates while driving, a fault has occurred in the electrical system. Volvo recommends that you visit an authorised Volvo workshop.

Fault in brake system



If this symbol illuminates, the brake fluid level may be too low.

² For certain engine variants, the symbol for low oil pressure is not used. Warnings are given via display text, see page 50.



Indicator and warning symbols

- Stop the car in a safe place and check the level in the brake fluid reservoir, see page 206. If the reservoir level is below **MIN** then the car should not be driven further. Volvo recommends that the car is transported to an authorised Volvo workshop to have the brake system checked.



If the BRAKE and ABS symbols illuminate at the same time, there may be a fault in the brake force distribution system.



1. Stop the car in a safe place and turn off the engine.
2. Restart the engine.
3. If both symbols extinguish, continue driving.
4. If the symbols remain illuminated, check the level in the brake fluid reservoir, see page 206.
5. If the brake fluid level is normal but the symbols are still illuminated, the car can be driven, with great care, to a workshop to

have the brake system checked. Volvo recommends that you seek assistance from an authorised Volvo workshop.

6. If the level in the reservoir is below **MIN** then the car should not be driven any further. Have the car transported to a workshop to have the brake system checked. Volvo recommends that you seek assistance from an authorised Volvo workshop.



WARNING

If the BRAKE and ABS symbols are lit at the same time, there is a risk that the rear end will skid during heavy braking.

Reminder – doors not closed

If one of the doors, the bonnet³ or the tailgate is not properly closed, the driver will be reminded of this.

Low speed



If the car moves at a speed less than 5 km/h, the information symbol illuminates and **DRIVER DOOR OPEN, PASSENGER DOOR OPEN** or **BONNET OPEN** is shown on the display. Stop the car safely as soon as possible and close the door or bonnet.

High speed



If the car is moving faster than 10 km/h, the symbol illuminates and one of the texts indicated in the preceding paragraph appears on the display.

Tailgate reminder



If the tailgate is open, this information symbol will illuminate and **TAILGATE OPEN** will appear on the display.

³ Only cars with alarm.

Information display

Messages

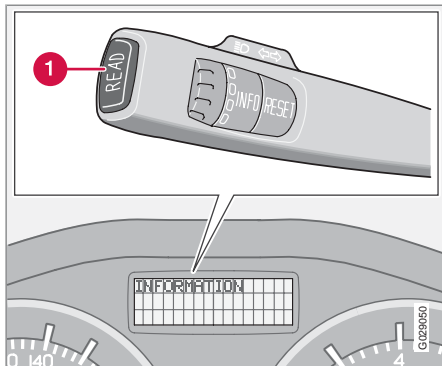

When a warning or indicator symbol illuminates the information display shows a supplementary message.

- Press the **READ** button (1).

Switch between messages with the **READ** button. Fault messages are stored in the memory until the fault is rectified.

NOTE

If a warning message appears while you are using the trip computer, the message must be read (press **READ**) before the previous activity can be resumed.

Message	Specification
STOP SAFELY^A	Stop the car in a safe manner and turn off the engine. Serious risk of damage.
SERVICE URGENT^A	Volvo recommends that an authorised Volvo workshop checks the car immediately.
SEE MANUAL^A	Read the Owner's Manual.
SERVICE REQUIRED^A	Volvo recommends that an authorised Volvo workshop checks the car as soon as possible.
HIGH ENGINE TEMP STOP ENGINE	Stop the car in a safe manner and turn off the engine. Serious risk of damage.
BOOK TIME FOR SERVICE	Time to book regular service. Volvo recommends that an authorised Volvo workshop carries out the service.

Message	Specification
TIME FOR REGULAR SERVICE	Time for regular service. Volvo recommends that an authorised Volvo workshop carries out the service. The timing is determined by the number of kilometres driven, number of months since the last service, engine running time and oil grade.
SERVICE OVERDUE	If the service intervals are not followed then the warranty does not cover any damaged parts. Volvo recommends that an authorised Volvo workshop carries out the service.
TRANSMISSION OIL CHANGE NEEDED	Volvo recommends that an authorised Volvo workshop checks the car as soon as possible.



Information display

Message	Specification
REMINDER CHECK OIL LEVEL	Check the oil level. The message is shown every 10 000 km (certain engine variants). For information on checking the oil level, see page 203.
SOOT FILTER FULL SEE OWNER MANUAL	Diesel particle filter requires regeneration, see page 277.
STC/DSTC SPIN CONTROL OFF	The function of the stability and traction control system is reduced, see page 149 for more variants.

Message	Specification
TRANSMISSION PERFORMANCE LOW	The gearbox cannot handle full capacity. Drive carefully until the message clears, see page 144. If shown repeatedly then Volvo recommends that an authorised Volvo workshop is contacted.

Message	Specification
TRANSMISSION OIL TEMP HIGH	Drive more smoothly or stop the car in a safe manner. Disengage the gear and run the engine at idling speed until the message clears. For more information, see page 144.
TRANSM OIL TEMP STOP SAFELY	Critical fault. Stop the car immediately in a safe manner. Volvo recommends that an authorised Volvo workshop is contacted. ^B

^A Part of message, shown together with information on where the problem has arisen.

^B For more messages concerning automatic transmission, see page 144.



Electrical socket

12 V electrical socket

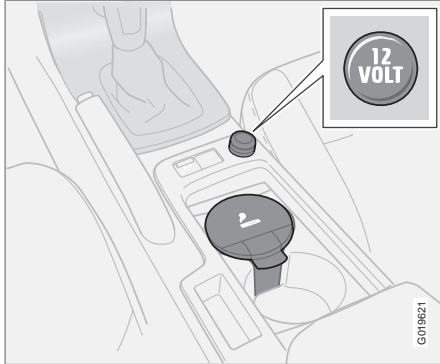

The electrical socket can be used for 12 V accessories, such as mobile phone chargers and coolers. The maximum current is 10 A. For the socket to supply current, the remote control key must be in at least position **I**.

WARNING

Always leave the plug in the socket when the socket is not in use.

Cigarette lighter*

Activate the lighter by pushing in the button. The button pops out when the lighter is hot. Pull out the lighter and light a cigarette on the heated coils.

Electrical socket in the rear seat

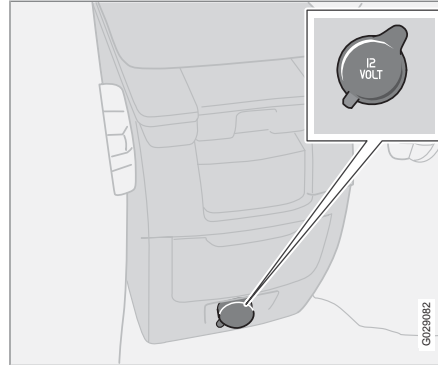

The electrical socket can be used for various accessories, such as mobile phone chargers and coolers.

NOTE

Cigarette lighter does not work in this socket.

It is designed for 12 V. The maximum current is 10 A. For the socket to supply current, the remote control key must be in at least position **I**.

WARNING

Always leave the plug in the socket when the socket is not in use.



Lighting panel

General

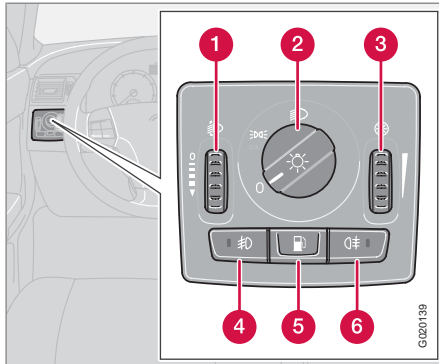

- 1 Thumbwheel for headlamp levelling
- 2 Light switches
- 3 Thumbwheel for adjusting display and instrument lighting
- 4 Front fog lamps*
- 5 Opening the fuel filler flap
- 6 Rear fog lamp

Position	Specification
0	Automatic/deactivated dipped beam. Only main beam flash.
☰☱	Position/parking lamps
☰☱☱	Automatic dipped beam. Main beam and main beam flash work in this position.

Headlamp levelling

The load in the car changes the vertical alignment of the headlamp beam, which could dazzle oncoming motorists. Avoid this by adjusting the height of the beam.

1. Turn the remote control key to position II.
2. Turn the headlamp control (2) to one of the end positions.
3. Roll the control (1) up or down respectively to raise or lower beam alignment.

Cars with Dual Xenon headlamps* have automatic headlamp levelling, so there is no control (1).

Position/parking lamps

Position/parking lamps can be switched on irrespective of remote control key position.

- Turn the headlamp control (2) to the centre position.

When the remote control key is in position II the position/parking lamps and number plate lighting are always on.

Headlamps

Automatic dipped beam*

Dipped beam comes on automatically when the remote control key is turned to position II, except when the headlamp control (2) is in the centre position. If necessary, the automatic dipped beam can be deactivated. Volvo recommends that this is performed by an authorised Volvo workshop.

Automatic dipped beam, main beam

1. Turn the remote control key to position II.
2. Dipped beam is activated by means of turning the headlamp control (2) clockwise to the end position.
3. Main beam is activated by means of moving the left-hand stalk switch towards the steering wheel to the end position and releasing it, see page 55.

* Option/accessory, for more information, see Introduction.



Lighting panel

The lamps are switched off automatically when the remote control key is turned to position **I** or **0**.

Instrument lighting

The instrument lighting is switched on when the remote control key is in position **II** and the headlamp control (2) is in one of the end positions. The lighting is automatically dimmed during the day and can be controlled manually at night.

- Roll the control up or down (3) for brighter or dimmer lighting.

Enhanced display lighting

To facilitate reading the odometer, trip meter, clock and outside temperature gauge, these illuminate when the car is unlocked and when the remote control key is removed from the ignition switch. The displays extinguish when the car is locked.

Fog lamps



NOTE

Regulations for use of fog lamps vary from country to country.

Front fog lamps*

The front fog lamps can be switched on along with the headlamps or the position lamps/parking lamps.

- Press the button (4).

The light in the button (4) illuminates when the front fog lamps are switched on.

Rear fog lamp

The rear fog lamp can only be switched on with the headlamps or the front fog lamps.

- Press the button (6).

The rear fog lamp indicator symbol on the combined instrument panel and the light in the button (6) illuminate when the rear fog lamp is switched on.

Fuel filler flap

Press button (5) to open the fuel filler flap when the car is unlocked, see page 124.

Brake light

The brake light automatically comes on during braking.

Emergency brake light and automatic hazard warning flashers*

Emergency brake lights (Adaptive Brake Lights) are activated in the event of sudden braking or if the ABS brakes are activated. This function means that the brake light flashes to immediately alert cars travelling behind.

The system is activated if ABS is used for more than 0.5 seconds or in the event of heavy braking, however, only when braking from speeds above 50 km/h. When the speed of the car is lower than 30 km/h the brake lights shine normally again and the hazard warning flashers are switched on automatically. The hazard warning flashers remain on until the car accelerates again but can be deactivated with the button for hazard warning flashers, see page 64.



Left-hand stalk switch

Stalk switch positions

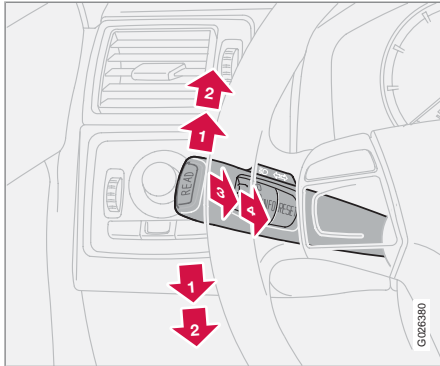

- 1 Short flash sequence, direction indicators
- 2 Continuous flash sequence, direction indicators
- 3 Main beam flash and switching from main to dipped beam
- 4 Home safe lighting and switching from dipped to main beam

¹ Factory settings.

Direction indicators

Continuous flash sequence

- Move the stalk switch up or down to end position (2).

The stalk switch remains in its end position and is moved back manually, or automatically by steering wheel movement.

Short flash sequence

- Move the stalk switch up or down to position (1) and release.

The direction indicators flash three times and the stalk switch returns to its home position.

Main beam flash

- Move the stalk switch gently towards the steering wheel to position (3).

Main beam comes on until the stalk switch is released. Main beam flash only works when the remote control key is inserted in the ignition switch.

Switching, main and dipped beam

The remote control key must be in position II and the headlamp control in end position, see page 53, for main beam to be switched on.

Activating main beam:

- Move the stalk switch towards the steering wheel to the end position (4) and release.

Deactivating main beam:

- Move the stalk switch towards the steering wheel to position (3) and release.

Home safe lighting

Some of the exterior lighting can be kept switched on to work as home safe lighting after the car has been locked. The standard delay is 30¹ seconds, but can be changed to 60 or 90 seconds, see page 75.

1. Remove the remote control key from the ignition switch.
2. Move the stalk switch towards the steering wheel to the end position (4) and release.
3. Get out of the car and lock the door.

Left-hand stalk switch

Trip computer*

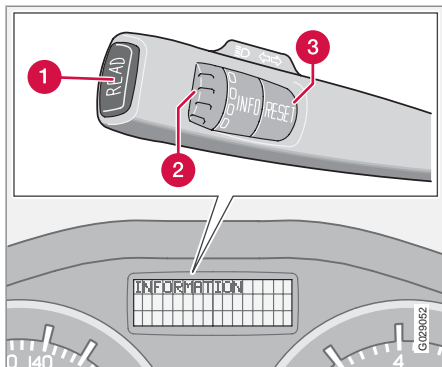

- 1 **READ** - confirms
- 2 Thumbwheel² - browse between menus and options in the trip computer list
- 3 **RESET**² - resets

Controls

To scroll through trip computer information turn the thumbwheel either up or down in steps. Continue turning to return to the starting point.

NOTE

If a warning message interrupts while you are using the trip computer, this message must be acknowledged. Acknowledge by pressing the **READ** button and revert to the trip computer function.

Functions

The trip computer displays the following information:

- **AVERAGE SPEED**
- **ACTUAL SPEED MPH***
- **INSTANTANEOUS**
- **AVERAGE**
- **KILOMETRES TO EMPTY TANK**
- **STC/DSTC**, see page 148

AVERAGE SPEED

When the ignition is switched off, the average speed is stored and used as the basis of the new value when you continue driving. Reset using the **RESET** button.

ACTUAL SPEED MPH

Current speed is displayed in mph.

INSTANTANEOUS

Current fuel consumption is calculated every second. The information on the display is

updated every couple of seconds. When the car is stationary, "--.-" appears on the display. During the period for regeneration³ fuel consumption may increase, see page 277.

AVERAGE

The average fuel consumption is stored when the ignition is switched off and remains until the function is reset. Reset using the **RESET** button.

NOTE

There may be a slight error in the reading if a fuel-driven heater is used.

KILOMETRES TO EMPTY TANK

The range to empty is calculated based on the average fuel consumption over the last 30 km. No guaranteed range remains when the display shows "--- km to empty tank". Refuel as soon as possible.

NOTE

There may be a slight error in the reading if fuel consumption is changed due to a change in driving style or if a fuel-driven heater is used for example.

² No function in cars without trip computer, fuel-driven parking heater as well as stability and traction control system.

³ Only applies to diesel cars with particle filter.

**Left-hand stalk switch****Resetting**

1. Select **AVERAGE SPEED** or **AVERAGE**
2. Reset with one press on the **RESET** button. Press and hold the **RESET** button for at least five seconds to reset the average speed and average consumption at the same time.

Right-hand stalk switch

Windscreen wipers

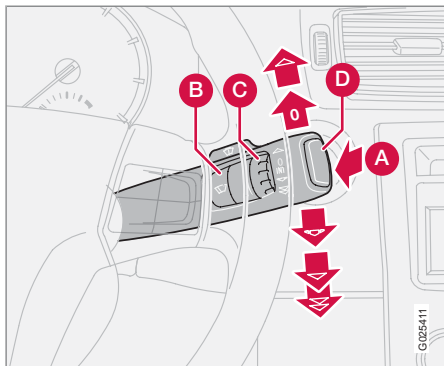

- A** Windscreen and headlamp washers
- B** Rain sensor - On/Off
- C** Thumbwheel
- D** Rear window wiper and washer

Windscreen wipers off



The windscreen wipers are off when the stalk switch is in position 0.

Single sweep



Raise the stalk switch to make a single sweep.

Intermittent wiping



You can adjust and set a suitable speed for intermittent wiping. Turn the thumbwheel (C) up for a shorter interval between sweeps. Turn it down to increase the delay.

Continuous wiping

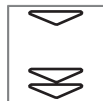

The wipers sweep at normal speed.

The wipers sweep at high speed.

! IMPORTANT

Before activating the wipers during winter – ensure that the wiper blades are not frozen in and that any snow or ice on the windscreen (and rear window) is scraped away.

! IMPORTANT

Use plenty of washer fluid when the wipers are cleaning the windscreen. The windscreen must be wet when the windscreen wipers are operating.

Windscreen/headlamp washer

Move the stalk switch toward the steering wheel to start the windscreen and headlamp washers. The wipers will make several more sweeps once the stalk switch is released.

High-pressure headlamp washing*

High-pressure headlamp washing consumes a large quantity of washer fluid. To save fluid, the headlamps are washed as follows:

Dipped beam selected with the switch on lighting panel:

The headlamps are washed the first time the windscreen is washed. Within the next ten minutes, they are washed every fifth wash cycle of the windscreen. In the event of a longer interval the headlamps are washed each time.

Parking/position lamps selected with the switch on the lighting panel:

- Dual Xenon headlamps are only washed every fifth wash cycle irrespective of the time that elapses.
- Halogen headlamps are not washed.

The switch on the lighting panel is in position 0:

- Dual Xenon headlamps are only washed every fifth wash cycle irrespective of the time that elapses.
- Halogen headlamps are not washed.



Right-hand stalk switch

Rear window wiper and washer

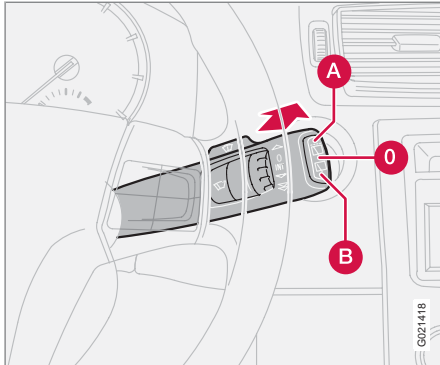

Move the stalk switch forward to start rear window washing and wiping. The wiper blade makes several extra sweeps once washing is finished. The button at the end of the stalk switch has three positions:

- A** Intermittent wiping: Depress the top of the button.
- 0** Neutral position: Function deactivated.
- B** Constant speed: Depress the bottom of the button.

Wiper – reversing

Engaging reverse gear while the windscreen wipers are on initiates intermittent rear window

wiping. If the rear window wiper is already on at normal speed, no change is made.

The function for intermittent wiping for reverse can be deactivated. Volvo recommends that you contact an authorised Volvo workshop.

Rain sensor*

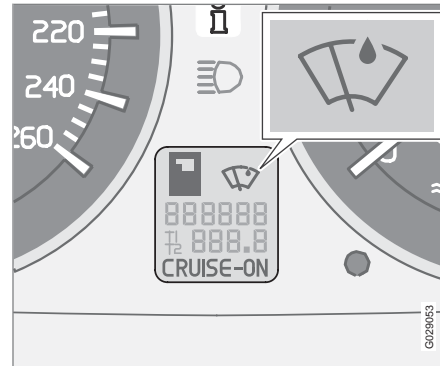

The rain sensor automatically activates the windscreen wipers based on how much water it detects on the windscreen. The sensitivity of the rain sensor can be adjusted using the thumbwheel (C), see page 58.

Turn the thumbwheel upwards for higher sensitivity and downwards for lower sensitivity, (an

extra sweep is made when the thumbwheel is turned upwards).

On/Off

When activating the rain sensor, the remote control key must be in position **I** or **II** and the windscreen wiper stalk switch must be in position **0** (not activated).

Activating the rain sensor:

- Press the button (B), see page 58. A display symbol shows that the rain sensor is active.

To turn the rain sensor off, either:

1. Press button (B)
2. Press the stalk switch downward to another wiper program. If the stalk switch is raised, the rain sensor will remain active, the wipers make an extra sweep and then return to rain sensor mode when the stalk is released to position **0** (not activated), see page 58.

The rain sensor is automatically deactivated when the remote control key is removed from the ignition switch or five minutes after the ignition is switched off.



Right-hand stalk switch

IMPORTANT

At an automatic car wash: Deactivate the rain sensor by pressing the button (B) while the remote control key is in position **I** or **II**. Otherwise, the windscreen wipers could start swiping and become damaged.

Thumbwheel

Use the thumbwheel to adjust the frequency of wiper sweeps when intermittent wiping is selected, or the sensitivity to rain when the rain sensor is selected.



Cruise control*

Activating

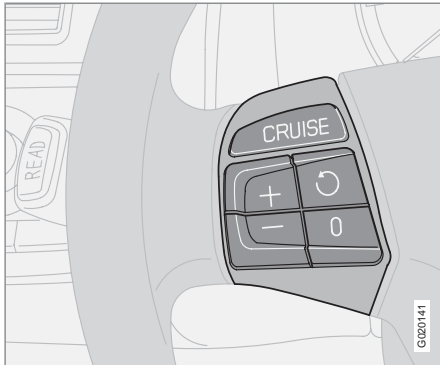

The controls for cruise control are to the left of the steering wheel.

Setting the desired speed:

1. Press the **CRUISE** button. **CRUISE** is shown on the combined instrument panel.
2. Touch **+** or **-** to lock the vehicle speed. **CRUISE-ON** appears in the combined instrument panel.

Cruise control cannot be engaged at speeds below 30 km/h or above 200 km/h.

Increasing or decreasing speed

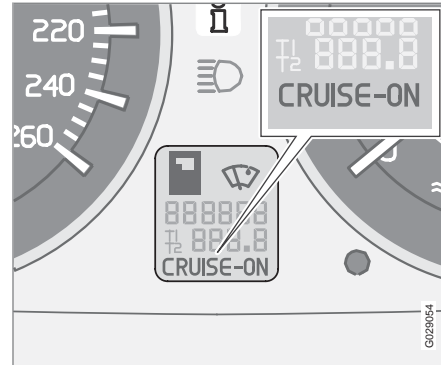

- Increase or decrease the speed by pressing and holding **+** or **-**. The speed of the car when the button is released is set as the new speed.

A brief press (less than half a second) on **+** or **-** changes the speed by 1 km/h or 1 mph¹.

 **NOTE**

A temporary increase in speed (less than one minute) using the accelerator, such as while overtaking, does not affect the cruise control setting. When you release the accelerator, the car will return to the programmed speed.

Temporary disengagement

- Press **0** to disengage the cruise control temporarily. **CRUISE** will be shown on the combined instrument panel. The speed set earlier is stored in the memory.

The cruise control is also temporarily disengaged when:

- the brake pedal or clutch pedal is depressed
- speed falls below 25-30 km/h¹ when travelling uphill
- the gear selector is moved to position **N**
- wheel spin or wheel lock-up occurs
- a temporary increase in speed lasts longer than one minute.

¹ Depending on engine type.



Cruise control*

Return to the set speed



– Press this button to resume the previously set speed. **CRUISE ON** appears on the combined instrument panel.

Disengaging

- Press **CRUISE** to disengage the cruise control. **CRUISE ON** clears on the combined instrument panel.



Keypad in the steering wheel*

Button functions



The four buttons at the bottom of the steering wheel keypad control the radio and the phone. The function of a button depends on which system is active. The steering wheel keypad can be used to scroll between preset stations, change CD tracks and adjust the volume.

- Press and hold one of the arrow keys to fast forward/reverse or search for the next station.

The phone must be switched on to adjust audio system settings. It must be activated with the **ENTER** key to enable control of the phone system with the arrow keys.

To return to Audio only, press **EXIT**.

Steering wheel adjustment, hazard warning flashers

Steering wheel adjustment

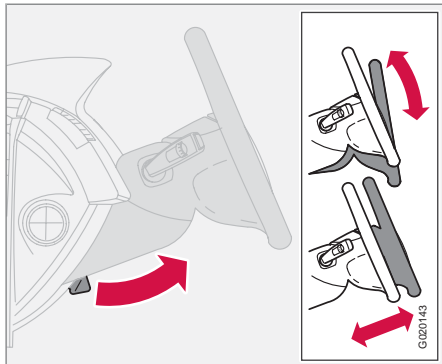

The steering wheel can be adjusted for both height and reach.

1. Pull the lever towards you to release the steering wheel.
2. Adjust the steering wheel to the position that suits you best.
3. Push back the lever to fix the steering wheel in place. If the lever is stiff, press the steering wheel lightly at the same time as you push the lever back.

WARNING

Adjust the steering wheel before driving off, never while driving. Before driving, check that the steering wheel is fixed in position.

Hazard warning flashers

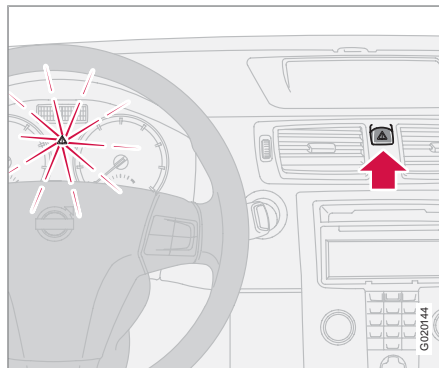

Use the hazard warning flashers (all direction indicators flash) when the car is stopped where it could be a traffic hazard or obstruction. Press the button to activate the function.

A sufficiently violent collision or heavy braking activates the hazard warning flashers automatically, see page 54. The function can be deactivated with the button.

NOTE

Regulations regarding the use of hazard warning flashers vary from country to country.



Parking brake

Parking brake (handbrake)



The lever is located between the front seats.

NOTE

The warning lamp symbol in the combined instrument panel illuminates irrespective of how hard the parking brake is applied.

WARNING

Make sure that children, other passengers or objects are not in danger of becoming trapped in any way when the parking brake is applied or released by the driver.

How to Apply the parking brake

1. Fully depress the foot brake pedal.
2. Pull the lever firmly.
3. Release the foot brake pedal and make sure that the car is at a standstill position.
4. If the vehicle moves then the parking brake lever must be pulled more firmly.

When parking a vehicle always put the gear selector in position **1** (for manual transmission) or **P** (for automatic transmission)

Parking on a hill

If the car is parked facing uphill; turn the wheels away from the kerb.

If the car is parked facing downhill; turn the wheels toward the kerb.

How to release the parking brake

1. Press the foot brake pedal down firmly.
2. Pull the parking brake lever up slightly, press the button, release the parking brake lever and release the button.

Power windows

Operation

The power windows are operated using the controls in the doors. The ignition key must be in position **I** or **II** for the power windows to operate.

The windows continue to work for a limited amount of time when the car is stopped and after the remote control key is removed, provided none of the doors is opened. Operate the windows with caution.

To open a window:

- Depress the front of the control.

To close a window:

- Raise the front of the control.

Remote control and lock buttons

To operate the power windows with lock buttons and remote control, see pages 116 and 124.

WARNING

Make sure that children and other passengers cannot be trapped in any way when closing the windows. Pay close attention if the windows are closed with the remote control.

Driver's door

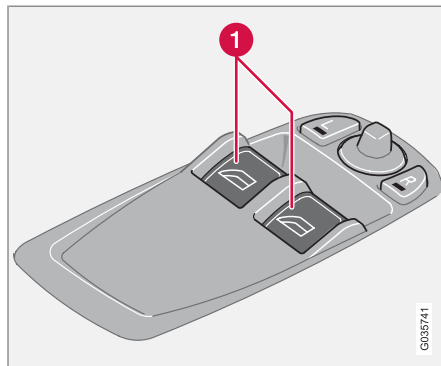

Controls, power windows front

The driver can operate both of the power windows from the driver's seat.

The windows can be opened and closed in two ways:

Manual operation

Depress one of the controls (1) gently or raise it gently. The power window opens or closes as long as the switch is actuated.

Automatic operation

Fully depress one of the controls (1) or raise it, then release. The side window will then open or close automatically. If the window is

obstructed by an object, the movement will stop.

WARNING

The function that interrupts the movement of the windows in the event of them being blocked works with both automatic and manual closing, although not with pinch protection deployed.

WARNING

If there are children in the car:

Remember to switch off the supply to the power windows by removing the remote control key if the driver leaves the car.

Make sure that children and other passengers cannot be trapped in any way when closing the windows.



Passenger seat

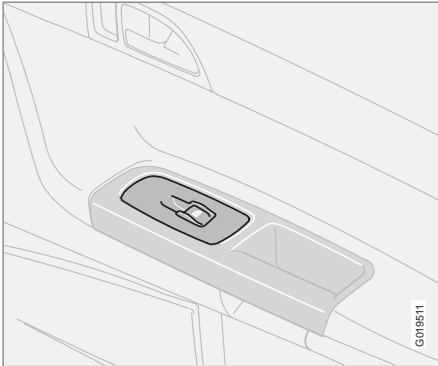

Passenger seat.

The control in the front passenger door operates that window only.



Windows, rearview and door mirrors

Interior rearview mirror

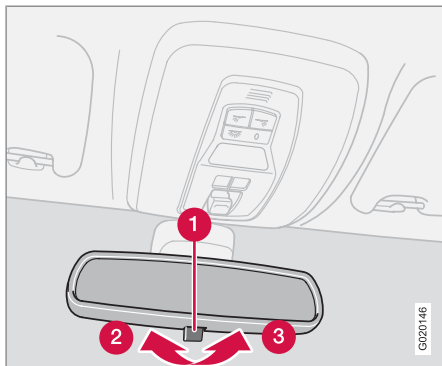

Bright light from behind could be reflected in the rearview mirror and dazzle the driver. Use dimming when disturbed by light from behind.

Dimming

- 1 Control for dimming
- 2 Normal position
- 3 Dimmed position.

Automatic dimming*

Bright light from behind is automatically dimmed by the rearview mirror. The control (1) is not available in mirrors with automatic dimming.

Interior rearview mirror with compass.*



The upper right-hand corner of the rearview mirror has an integrated display that shows the compass direction in which the front of the car is pointing. Eight different directions are shown with English abbreviations: **N** (north), **NE** (north east), **E** (east), **SE** (south east), **S** (south), **SW** (south west), **W** (west) and **NW** (north west).

Calibrating the compass

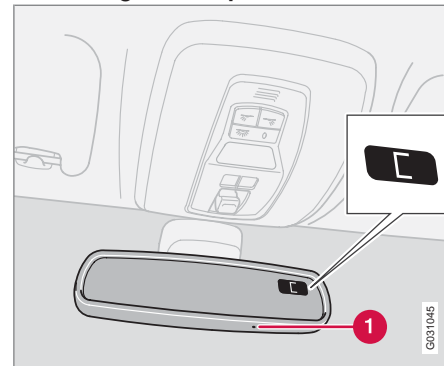

The earth is divided into 15 magnetic zones. The compass is set for the geographic area to which the car was delivered. The compass should be calibrated if the car is moved across several magnetic zones.

1. Stop the car in a wide open area with the engine running at idling speed.
2. Press and hold button (1) for at least 6 seconds. Following which, the character **C** is shown (the button is concealed so use a paper clip for example to press it in).
3. Press and hold button (1) for at least 3 seconds. The number of the current magnetic zone is shown.



Windows, rearview and door mirrors

4. Press the button (1) repeatedly until the number for the required magnetic zone (1–15) is shown, refer to the map of magnetic zones for the compass.
5. Wait until the display resumes showing the character C.
6. Following which, press and hold the button in for 9 seconds and select L for left-hand drive cars and R for right-hand drive.
7. Drive slowly in a circle at a speed of no more than 10 km/h until a compass direction is shown in the display, indicating that calibration is complete.

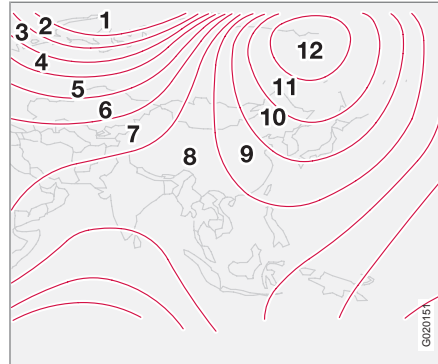

Magnetic zones, Asia.



Magnetic zones, Australia.

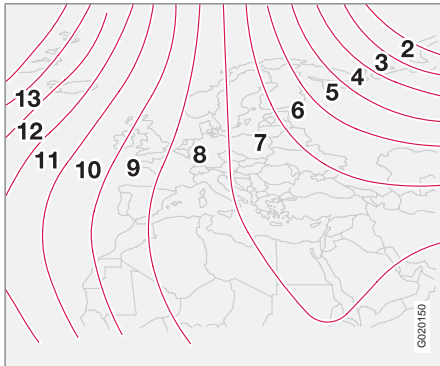

Magnetic zones, Europe.

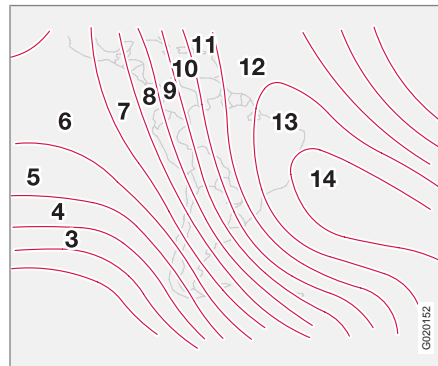

Magnetic zones, South America.

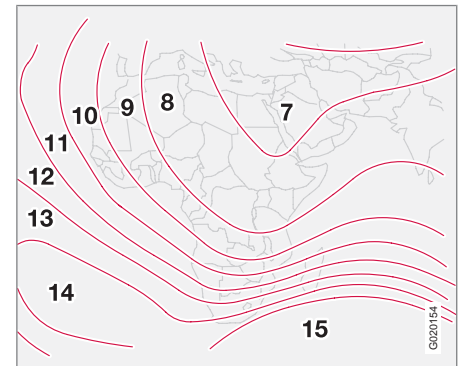

Magnetic zones, Africa.

Windows, rearview and door mirrors

Door mirrors

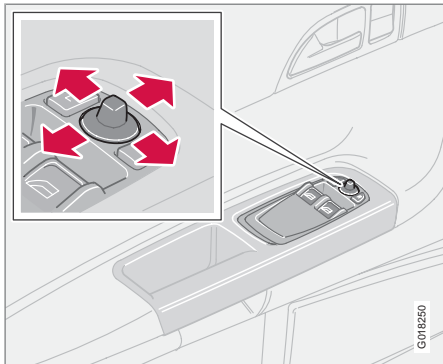

The controls for adjusting the two door mirrors are at the front of the driver's door armrest. The rearview mirrors can be operated in ignition position **I** and **II**.

1. Press the **L** button for the left-hand door mirror or the **R** button for the right-hand door mirror. The light on the button illuminates.
2. Adjust the position with the joystick in the centre.
3. Press the **L** or **R** button again. The light goes out.

Retractable power door mirrors*

The mirrors can be retracted for parking/driving in narrow spaces. This can be carried out in ignition position **I** and **II**.

Retracting the mirrors

1. Press down the **L** and **R** buttons at the same time.
2. Release the buttons. The mirrors automatically stop in the fully retracted position.



WARNING

Both door mirrors are the wide angled type to provide optimal vision. Objects may appear further away than they actually are.

Folding out the mirrors

1. Press down the **L** and **R** buttons at the same time.
2. Release the buttons. The mirrors automatically stop in the fully extended position.

Automatic retracting/extending

When the car is locked/unlocked with the remote control or using the Keyless system, see page 120, the door mirrors are automatically retracted/extended.



NOTE

The door mirrors will not be extended automatically during unlocking if they were retracted using the controls in the door.

If the car is locked with the remote control and is then started, the door mirrors will still be extended.

The function can be activated/deactivated under **Car settings...** → **Mirror fold on locking**, see page 75 for a description of the menu system.

Resetting to neutral

Mirrors that have been moved out of position by an external force must be reset to the neutral position for electric retracting and extending to work.

1. Use the **L** and **R** buttons to retract the mirrors.
2. Extend the mirrors again with the **L** and **R** button. The mirrors are now reset to the neutral.

Home safe and approach lighting

The light* in the door mirrors illuminates when the approach lighting or home safe lighting is activated.



Windows, rearview and door mirrors

Blind Spot Information System, BLIS*

BLIS is an information system that under certain conditions can help to draw the driver's attention to vehicles moving in the same direction in the so-called "blind spot", see page 152.

Water and dirt-repellent coating*



The front side windows are treated with a coating which improves the view in poor weather conditions. For information on maintenance, see page 191.



IMPORTANT

Do not use a metal ice scraper to remove ice from the windows. The water and dirt-repellent coating could be damaged.



Power sunroof*

Open positions

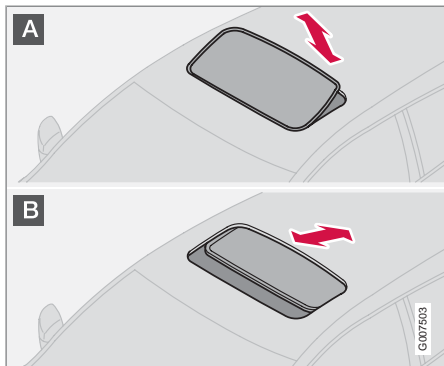

The sunroof controls are located in the roof panel. The sunroof can be opened in two positions:

- A** Ventilation position, up at the rear edge
- B** Sliding position, backwards/forwards

The remote control key must be in position **I** or **II**.

WARNING

If there are children in the car:
Switch off the supply to the power sunroof by removing the remote control key if the driver leaves the car.

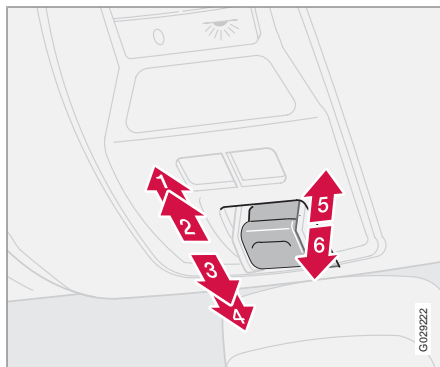

- 1** Opening, automatic
- 2** Opening, manual
- 3** Closing, manual
- 4** Closing, automatic
- 5** Opening, ventilation position
- 6** Closing, ventilation position

Ventilation position

Open:

- Press the rear edge of the control (5) upward.

Close:

- Pull the rear edge of the control (6) downward.

From ventilation position to fully open sunroof:

- Pull the control rearward to the end position (1) and release.

Sliding position

Automatic operation

- Pull the control past the point of resistance (2) to the rear end position (1) or past the point of resistance (3) to the forward end position (4) and release. The sunroof opens/closes completely.

Manual operation

Open:

- Pull the control rearward to the point of resistance (2). The sunroof moves to maximum open position as long as the button is kept depressed.

Close:

- Press the control forward to the point of resistance (3). The sunroof moves to



Power sunroof*

closed position as long as the button is kept depressed.

WARNING

The sunroof's pinch-protection function only operates during automatic closing, not manual closing.

Closing with remote control or lock button

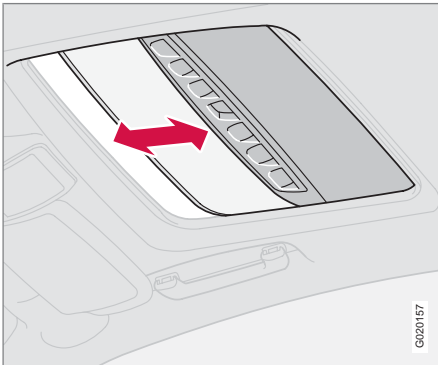

- One long press on the lock button closes the sunroof and all the windows. The doors and the tailgate are locked.

If you need to interrupt closing:

- Press the lock button again.

WARNING

Make sure that children or other passengers are not in danger of becoming trapped in any way when closing the sunroof with the remote control. Always operate the sunroof with caution.

Sunscreen

The sunroof features a manual, sliding interior sunscreen. The sunscreen slides back automatically when the sunroof is opened. Grip the handle and slide the screen forward to close it.

Pinch protection

The sunroof's pinch protection function is activated if the hatch is blocked by an object. If blocked, the sunroof will stop and automatically open to the previous position.

WARNING

The sunroof's pinch protection function only operates during automatic closing, not during manual closing.

Make sure that nobody is in danger of becoming trapped in any way when closing the sunroof.



Personal preferences

Possible settings

Personal preferences can be set for some of the car's functions. This applies to locks, climate control and audio functions. For audio functions, see page 230.

Control panel

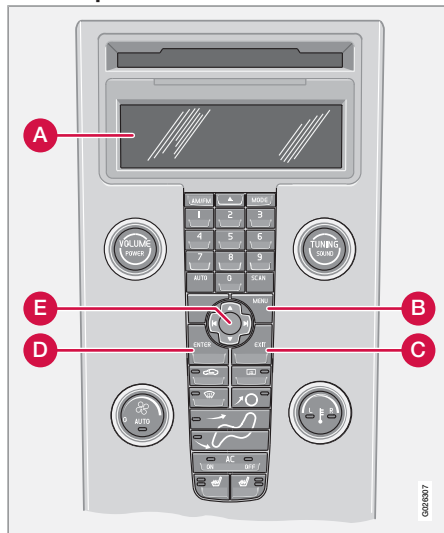

Control panel.

- A** Display
- B** MENU
- C** EXIT
- D** ENTER
- E** Navigation

Use

The settings are shown on the display (A).

Open the menu to enter settings:

1. Press **MENU** (B).
2. Scroll, for example, to **Car settings** with the navigation button (E).
3. Press **ENTER** (D).
4. Select an alternative with the navigation button (E).
5. Press **ENTER** to activate the selection.

Close the menu:

- Press **EXIT** (C) for approximately one second.

Clock, adjustment

The hour and minute are each adjusted separately.

1. Use the numbers on the keypad or "arrow up" or "arrow down" on the navigation button (E).
2. Select the number for adjustment using "arrow right" or "arrow left" on the navigation button.
3. Press **ENTER** to start the clock.

NOTE

If the car has a 12-hour clock then **AM/PM** is selected using "arrow up" or "arrow down" after the final minute number has been adjusted.

Climate settings

Automatic blower adjust

The fan speed can be set to **AUTO** mode in cars equipped with ECC:

- Select from **Low**, **Normal** and **High**.

Recirculation timer

When the timer is active, the air recirculates for 3-12 minutes, depending on the outside air temperature.



Personal preferences

- Select **On/Off** depending on whether or not you wish the recirculation timer to be active.

Reset all

Resets the climate function options to the factory settings.

Car settings

Retract mirrors when locking*

When the car is locked/unlocked with the remote control the door mirrors can be retracted/extended automatically. The **On/Off** options are available.

Reduced guard*

The deadlocks function can be temporarily deactivated and the alarm level reduced if someone wishes to remain in the car and the doors have to be locked from the outside. The **Activate once** and **Ask on exit** options are available, see pages 125 and 128.

Unlock confirm. light

The hazard warning flashers can provide feedback when the car is unlocked with the remote control. The **On/Off** options are available.

Lock confirm. light

The hazard warning flashers can provide feedback when the car is locked with the remote control. The **On/Off** options are available.

Doors – auto lock

When the speed of the car exceeds 7 km/h the doors and tailgate can be locked automatically. The **On/Off** options are available.

Doors unlock

There are two alternatives for unlocking:

- **All doors** – one press of the remote control unlocks both doors and the tailgate.
- **Driver's door first, then all others** – one press of the remote control unlocks the driver's door. A second press then unlocks the passenger door and the tailgate.

Keyless entry

- **All doors** - both doors and the tailgate are unlocked simultaneously¹.
- **Either front door** – any door or the tailgate can be unlocked separately.

Simultaneous closing/opening of all windows

This function can be selected for the lock button on the remote control and the front doors' central locking button, as well as the outside

door handle button on cars with the keyless system:

- **Auto. close all windows** - all windows and the sunroof are closed simultaneously with one long press on the lock button.

This function can be selected for the unlock button on the remote control and the front doors' central locking button:

- **Auto. open all windows** – all windows are opened simultaneously with one long press on the unlock button.

Approach lighting

Select the time the car's lights should remain on when the approach lighting button is pressed. The following alternatives are available: **30/60/90 seconds**.

Home safe lighting

Select the time the car's lights should remain on when the left-hand stalk switch is pulled back after the remote control key has been removed. The following alternatives are available: **30/60/90 seconds**.

Information

- **VIN number** - (Vehicle Identification Number) is the car's unique identity number.
- **Number of keys** - The number of keys registered for the car is shown.

¹ Both doors and the tailgate can also be locked simultaneously.

HomeLink® *

General

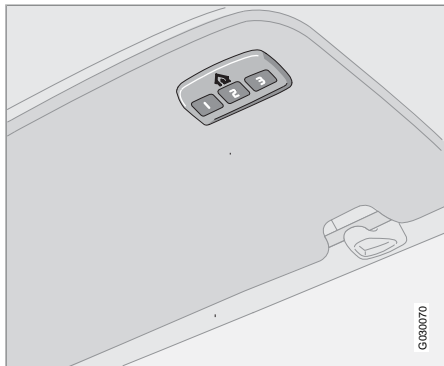

HomeLink® is a programmable remote control which can control up to three different devices (e.g. garage door, alarm system, outdoor lighting and indoor lighting etc.) and in doing so replace their remote controls. HomeLink is supplied built into the left-hand sun visor.

The HomeLink® panel consists of three programmable buttons and one indicator lamp.

 **NOTE**

HomeLink is designed to be inoperable if the car is locked from the outside.

Save the original remote controls for future programming (e.g. for purchasing a new car).

Erase the programming for the buttons when selling the car.

Metallic sun visors should not be used in cars equipped with HomeLink. This could have a negative effect on the HomeLink function.

Operation

When HomeLink® is fully programmed it can be used in place of the separate original remote controls.

Depress the programmed button to activate the garage door, alarm system etc. The indicator lamp illuminates for the time that the button is kept depressed.

 **NOTE**

In the event that the ignition is not activated, HomeLink operates for 30 minutes after the driver's door has been opened.

The original remote controls can of course be used in parallel with HomeLink®.

 **WARNING**

If HomeLink® is used to operate a garage door or gate, ensure that nobody is in the vicinity of the door or gate while it is in motion.

Do not use the HomeLink® remote control for any garage door that does not have safety stop and safety reverse. The garage door must react immediately when it detects that something is preventing its movement, and stop directly and reverse. A garage door without these characteristics could cause personal injury. For further information - contact the supplier via the Internet: www.homelink.com.

Programming for the first time

The first step erases the memory in HomeLink® and must not be carried out when only one individual button is being reprogrammed.

1. Depress the two outer buttons and do not release until the indicator lamp starts to flash after approx. 20 seconds. The flashing indicates that HomeLink® is set in "learn mode" and is ready to be programmed.



- Position the original remote control 5-30 cm from HomeLink®. Monitor the indicator lamp.

The particular distance that is required between the original remote control and HomeLink® depends on the programming of the device in question. Perhaps several attempts will be required at different distances. Maintain each position for approx. 15 seconds before trying a new one.

- Depress the button for the original remote control and the button to be programmed on HomeLink® simultaneously. Do not release the buttons until the indicator lamp has changed over from slow to rapid flashing. The rapid flashing indicates successful programming.
- Test the programming by depressing the programmed button on HomeLink® and watching the indicator lamp:

- **Constant glow:** The indicator lamp illuminates with a constant glow when the button is kept depressed, this indicates that the programming is complete. The garage door, gate or similar should now be activated when the programmed HomeLink® button is depressed.

- **Glow not constant:** The indicator lamp flashes quickly for approx. 2 seconds and then changes over to a constant glow for approx. 3 seconds. This process is repeated for approx. 20 seconds and indicates that the device has a "rolling code". The garage door, gate or similar is not activated when the programmed HomeLink® button is depressed. Continue the programming in accordance with the following.
- Locate the "programming button"¹ on the receiver for the garage door for example, normally located close to the antenna's bracket on the receiver. If you have difficulty in finding the button - consult the supplier's manual, or contact the supplier via the Internet: www.homelink.com.
 - Depress and release the "programming button". The button flashes for approx. 30 seconds and the next step must be carried out within this period.
 - Depress the programmed button on HomeLink®, while the "programming button" is still flashing, keep it depressed for approx. 3 seconds and then release. Repeat the press/hold/release sequence up to 3 times to conclude the programming.

Programming individual buttons

To reprogram an individual button, proceed in accordance with the following:

- Depress the required button on HomeLink® and do not release until step 3 has been completed.
- When the indicator lamp on HomeLink® starts to flash, after approx. 20 seconds, position the original remote control 5-30 cm from HomeLink®. Monitor the indicator lamp.

The particular distance that is required between the original remote control and HomeLink depends on the programming of the device in question. Perhaps several attempts will be required at different distances. Maintain each position for approx. 15 seconds before trying a new one.

- Depress the button on the original remote control. The indicator lamp will start to flash. When the flashing has changed over from a slow to a rapid flashing - release both buttons. The rapid flashing indicates successful programming.
- Test the programming by depressing the programmed button on HomeLink and watching the indicator lamp:

¹ Button designation and colour vary depending on manufacturer.



HomeLink® *

- **Constant glow:** The indicator lamp illuminates with a constant glow when the button is kept depressed, this indicates that the programming is complete. The garage door, gate or similar should now be activated when the programmed HomeLink® button is depressed.
 - **Glow not constant:** The indicator lamp flashes quickly for approx. 2 seconds and then changes over to a constant glow for approx. 3 seconds. This process is repeated for approx. 20 seconds and indicates that the device has a "rolling code". The garage door, gate or similar is not activated when the programmed HomeLink® button is depressed. Continue the programming in accordance with the following.
5. Locate the "programming button²" on the receiver for the garage door for example, normally located close to the antenna's bracket on the receiver. If you have difficulty in finding the button - consult the supplier's manual, or contact the supplier via the Internet: www.homelink.com.
 6. Depress and release the "programming button". The button flashes for approx. 30 seconds and the next step must be carried out within this period.
 7. Depress the programmed button on HomeLink®, while the "programming button" is still flashing, keep it depressed for approx. 3 seconds and then release. Repeat the press/hold/release sequence up to 3 times to conclude the programming.

Erasing programming

It is only possible to erase the programming for all the buttons on HomeLink, not for individual buttons.

- Depress the two outer buttons and do not release until the indicator lamp starts to flash after approx. 20 seconds.
 - > HomeLink® is now set in so-called "learn mode" and is ready to be programmed once more, see page 76.

² Button designation and colour vary depending on manufacturer.

* Option/accessory, for more information, see Introduction.



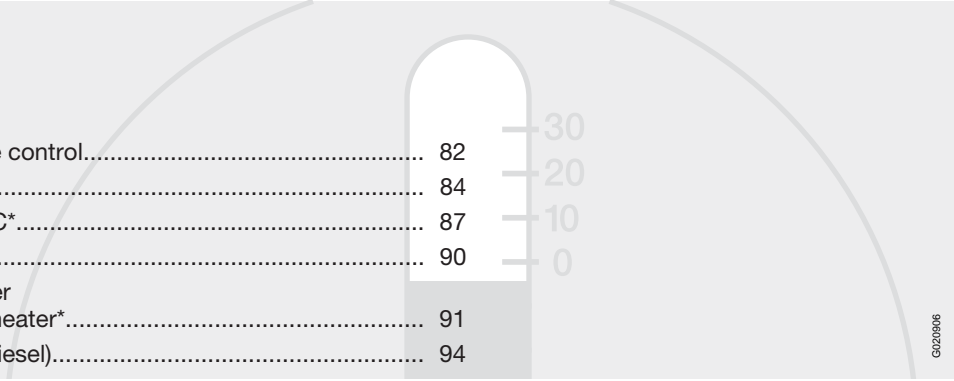

General information on climate control.....	82	— 30
Manual climate control, AC.....	84	— 20
Electronic climate control, ECC*.....	87	— 10
Air distribution.....	90	— 0
Fuel-driven engine block heater and passenger compartment heater*.....	91	
Fuel-driven auxiliary heater* (diesel).....	94	

CLIMATE CONTROL



03



General information on climate control

Air conditioning

The climate control system cools or heats as well as dehumidifies the air in the passenger compartment. The car is equipped with either manual (AC) or electronic climate control (ECC, Electronic Climate Control).

NOTE

The air conditioning system can be switched off, but to ensure the best possible air in the passenger compartment and prevent the windows from misting, it should always be on.

Misting windows

Remove misting on the insides of the windows by first using the defroster function.

To reduce the risk of misting, clean the windows with a normal window cleaning agent.

Ice and snow

Remove ice and snow from the climate control air intake (the grille between the bonnet and the windscreen).

Fault tracing and repair

Volvo recommends that you only entrust fault tracing and repair of the climate control system to an authorised Volvo workshop.

Refrigerant

The air conditioning system contains R134a refrigerant. This refrigerant contains no chlorine, which means that it is harmless to the ozone layer. The system must only be charged with R134a refrigerant, see also page 271. Volvo recommends that an authorised Volvo workshop carries out this work.

Passenger compartment filter

All air entering the car's passenger compartment is only cleaned with one filter. This must be replaced at regular intervals. Follow the Volvo Service Programme for the recommended replacement intervals. If the car is used in a severely contaminated environment, it may be necessary to replace the filter more often.

NOTE

There are different types of passenger compartment filter. Make sure that the correct filter is fitted.

Display

There is a display above the climate control panel. This displays climate control settings.

Personal preferences

You can set preferences for two climate control functions:

- Fan speed in **AUTO** mode (applies only to cars with ECC).
- Recirculation timer for passenger compartment air.

For information about these settings, see page 74.



General information on climate control

Air vents in the dashboard

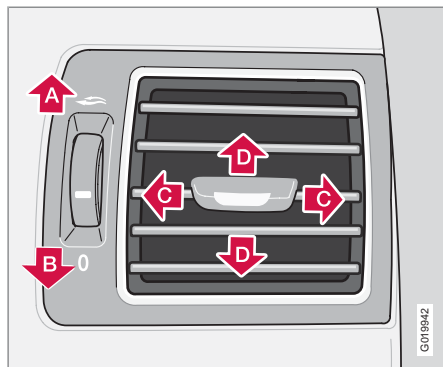

- A** Open
- B** Closed
- C** Lateral airflow
- D** Vertical airflow

Aim the outer vents towards the side windows to remove misting from the front side windows.

During cold weather - Close the centre vents for optimum comfort and best demisting.

ECC*

Actual temperature

The temperature you select corresponds to the physical experience with reference to factors such as air speed, humidity and solar radiation in and around the car.

The system includes a sun sensor which detects the side from which the sun is shining into the passenger compartment. This means that the temperature can differ between the right and left-hand air vents despite the controls being set for the same temperature on both sides.

Sensor location

- The sun sensor is on the top side of the dashboard.
- The temperature sensor for the passenger compartment is behind the climate control panel.
- The outside temperature sensor is located on the door mirror.
- The humidity sensor is located in the interior rearview mirror.

i NOTE

Do not cover or block the sensors with clothing or other objects.

Side windows and sunroof

To ensure that the air conditioning works satisfactorily, close all side windows and the sunroof (if fitted).

Acceleration

The air conditioning system switches off temporarily at full throttle. You may briefly feel a temporary rise in temperature.

Condensation

In warm weather, condensation from the air conditioning may drip under the car. This is normal.



Manual climate control, AC

Control panel

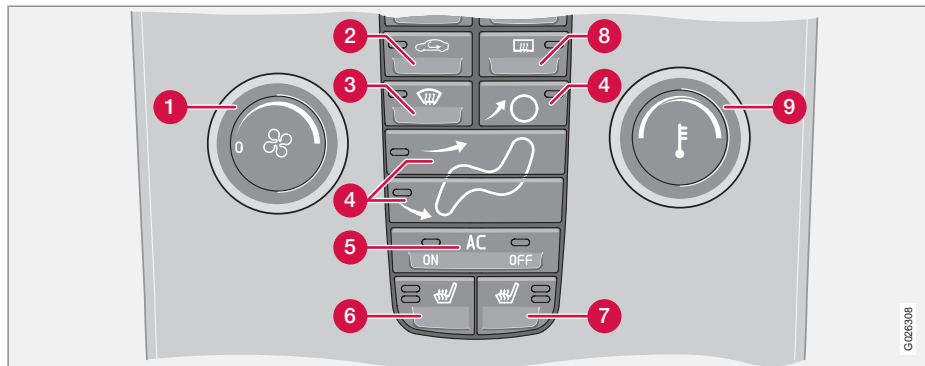

- 1 Fan
- 2 Recirculation
- 3 Defroster
- 4 Air distribution
- 5 **AC ON/OFF** – Air conditioning On/Off
- 6 Heated front left seat
- 7 Heated front right seat
- 8 Rear window and door mirror defrosters
- 9 Temperature

Functions

1. Fan

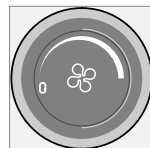

Increase or decrease the fan speed by turning the knob.

If the knob is turned anticlockwise and the fan indicator in the display goes out, the fan and the air conditioning are switched off. The display shows the fan symbol and **OFF**.

2. Recirculation

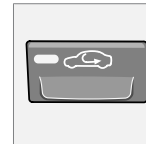

Recirculation can be used to shut out bad air, exhaust fumes, etc. from the passenger compartment. The air in the passenger compartment is recirculated. No outside air is taken into the car. Recirculation (together with the air conditioning system) cools the passenger compartment more quickly in hot weather. If the air in the car recirculates for too long then there is a risk of the windows misting.

G 02E308



Manual climate control, AC

Timer

The timer function reduces the risk of icing, misting and bad air (if recirculation is selected). See page 74, for activating/deactivating the function. When the Defroster (3) program is selected, recirculation is deactivated.

3. Defroster



Used to quickly remove misting and ice from the windscreen and side windows. Air flows to the windows at high fan speed. The light in the defroster button illuminates when the function is active.

The following also takes place when the defroster function is activated in order to provide maximum dehumidification in the passenger compartment:

- the air conditioning (AC) is automatically switched on (can be switched off with the **AC** button (5))
- recirculation is automatically disengaged.

When the defroster is switched off the climate control returns to the previous settings.

4. Air distribution



The airflow can be distributed to the windows, dashboard vents or floor by pressing the air distribution buttons.

A symbol on the display above the climate control

panel and an illuminated light in the relevant button indicate which function has been selected.

Refer to the table on page 90.

5. AC – On/Off (ON/OFF)

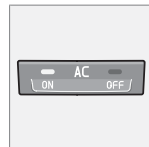

ON: The air conditioning is on. It is controlled by the system's AUTO function. This way, incoming air is cooled and dehumidified.

OFF: The air conditioning is off.

When the defroster function is activated the air conditioning is automatically switched on (can be switched off with the **AC** button). An illuminated lamp above **ON** and **OFF** respectively in the button shows the function selected.

6. and 7. Heated front seats*



Higher heat:

- Press the button once – both lights illuminate.

Lower heat:

- Press the button twice – one light illuminates.

Heat off:

- Press the button three times – light not illuminated.

8. Rear window and door mirror defrosters



Heating is used to quickly remove misting and ice from the rear window and door mirrors. Press the button once to start simultaneous rear window and rearview mirror defrosting. The function is

active if one lamp is illuminated in the button.

The function is switched off manually or automatically. Switch off manually with one press



Manual climate control, AC

on the button. Automatic switching off disconnects the rear window and door mirrors after 12 – 20 minutes depending on outside temperature.

During cold weather the defrosting* also continues after 20 minutes in order to keep the rear window and door mirrors free of ice and mist. The intensity of the defrosting can be adapted to the outside temperature. This function must be switched off manually.

9. Temperature

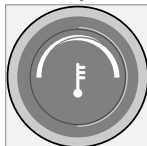

Select cooling or heating for both driver and passenger side.



Electronic climate control, ECC*

Control panel

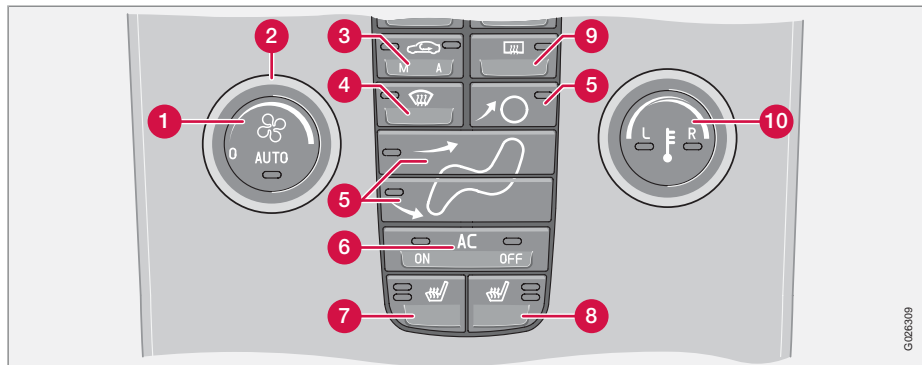

- 1 **AUTO**
- 2 Fan
- 3 Recirculation/Air quality system
- 4 Defroster
- 5 Air distribution
- 6 **AC ON/OFF** – Air conditioning On/Off
- 7 Heated front left seat
- 8 Heated front right seat
- 9 Rear window and door mirror defrosters
- 10 Temperature selector

Functions

1. AUTO

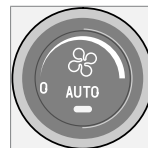

The **AUTO** function automatically regulates climate control and maintains the selected temperature. The AUTO function controls heating, air conditioning, fan speed, recirculation, and air

distribution.

If you select one or more manual functions, the other functions continue to be controlled automatically. All manual settings are switched off when **AUTO** is switched on. The display shows **AUTO CLIMATE**.

2. Fan



Turn the knob to increase or decrease fan speed. If **AUTO** is selected then fan speed is regulated automatically. The previously set fan speed is disengaged.

i **NOTE**

If the knob is turned anticlockwise and the fan indicator in the display goes out, the fan and the air conditioning are switched off. The display shows the fan symbol and **OFF**.



Electronic climate control, ECC*

3. Recirculation

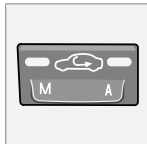

The function is selected to shut out bad air, exhaust gases etc. from the passenger compartment. The air in the passenger compartment is recirculated, i.e. no outside air is taken into the car when

this function is activated. If the air in the car recirculates for too long, there is a risk of misting on the insides of the windows.

Timer

The timer function reduces the risk of icing, misting and bad air (if recirculation is selected). To activate/deactivate the function see page 74.

i NOTE

When Defroster (4) is selected, recirculation is always deactivated.

3. Air quality system*

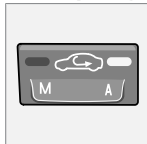

Same button as recirculation.

The air quality system consists of a multi-filter and a sensor. The filter separates gases and particles to reduce the levels of odours and pollution in the passenger compartment. When the sensor detects polluted outside air, the air intakes are closed and the air in the passenger compartment is recirculated. A green light (A) illuminates in the button when the air quality sensor is active.

Activating the air quality sensor:

- Press **AUTO** (1) to activate the air quality sensor (normal setting).

Or:

- Switch between three functions by pressing repeatedly the recirculation button.
- Air quality sensor engaged – the light (A) illuminates.
- No recirculation engaged, provided it is not required for cooling in hot weather – light not illuminated.
- Recirculation engaged – the light (M) illuminates.

Keep the following in mind:

- As a rule, the air quality sensor should always be engaged.
- Recirculation is limited in cold weather to avoid misting.

- The defroster functions for the front, side and rear windows can be used to demist the windows.

4. Defroster



Used to quickly remove misting and ice from the windscreen and side windows. Air flows to the windows at high fan speed. The light in the defroster button illuminates when the function is active.

The following also takes place when the defroster function is activated in order to provide maximum dehumidification in the passenger compartment:

- the air conditioning (AC) is automatically switched on (can be switched off with the **AC** button (6))
- recirculation is automatically disengaged.

When the defroster is switched off the climate control returns to the previous settings.

5. Air distribution

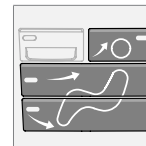

The airflow can be distributed to the windows, dashboard vents or floor by pressing the air distribution buttons.



Electronic climate control, ECC*

A symbol on the display above the climate control panel and an illuminated light in the relevant button indicate which function has been selected.

Refer to the table on page 90.

6. AC – On/Off (ON/OFF)

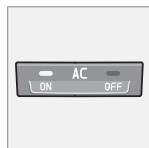

ON: The air conditioning is on. It is controlled by the system's AUTO function. This way, incoming air is cooled and dehumidified.

OFF: Off

When the defroster function is activated the air conditioning is automatically switched on (can be switched off with the **AC** button).

i NOTE

The climate control system's demisting function with humidity sensor is significantly reduced with the air conditioning in deactivated mode (**OFF**), as well as with manually selected air distribution and fan speed.

7 and 8. Heated front seats*



To activate front seat heating:

Higher heat:

- Press the button once – both lights illuminate.

Lower heat:

- Press the button twice - one light illuminates.

Heat off:

- Press the button three times – light not illuminated.

9. Rear window and door mirror defrosters



Heating is used to quickly remove misting and ice from the rear window and door mirrors. Press the button once to start simultaneous rear window and rearview mirror defrosting. The function is

active if one lamp is illuminated in the button.

The function is switched off manually or automatically. Switch off manually with one press

on the button. Automatic switching off disconnects the rear window and door mirrors after 12 – 20 minutes depending on outside temperature.

During cold weather the defrosting* also continues after 20 minutes in order to keep the rear window and door mirrors free of ice and mist. The intensity of the defrosting can be adapted to the outside temperature. This function must be switched off manually.

10. Temperature selector



The temperatures on the driver and passenger sides can be set independently.

Press the button once to activate one side only. Press again to activate the other

side. Press the button a third time to activate both sides.

The active side is indicated by the button's light and in the display above the climate control panel.

When the car is started, the most recent setting is resumed.

i NOTE

Heating or cooling cannot be hastened by selecting a higher or lower temperature than the actual desired temperature.



03 Climate control

Air distribution

03

	Air distribution	Use:		Air distribution	Use:
	Air to windows. Some air flows from the air vents. The air is not recirculated. Air conditioning is always engaged.	to remove ice and misting quickly.		Air to the floor and windows. Some air flows from the dashboard air vents.	to ensure comfortable conditions and good demisting in cold or humid weather.
	Air to windscreen and side windows. Some air flows from the air vents.	to prevent misting and icing in a cold and humid climate. (Not for low fan speed.)		Air to floor and from dashboard air vents.	in sunny weather with cool outside temperatures.
	Airflow to windows and from dashboard air vents.	to ensure good comfort in warm, dry weather.		Air to floor. Some air flows to the dashboard air vents and windows.	to warm the feet.
	Airflow to the head and chest from the dashboard air vents.	to ensure efficient cooling in warm weather.		Airflow to windows, from dashboard air vents and to the floor.	to provide cooler air for the feet or warmer air to the upper body in cold weather or hot, dry weather.



Fuel-driven engine block heater and passenger compartment heater*

General information about heaters

The parking heater heats the engine and passenger compartment and can be started directly or with the timer.

Two different times can be selected using the timer. Here, time refers to the time when the car is heated and ready. The car's electronic system calculates when heating should be started based on the outside temperature.

The heater cannot start if the outside temperature exceeds 15 °C. At -10 °C or lower the maximum running time of the parking heater is 50 minutes.

WARNING

The car must be outdoors when the petrol or diesel heater is used.

NOTE

When the parking heater is active there may be smoke from underneath the car, which is perfectly normal.

Refuelling



Warning decal on fuel filler flap.

WARNING

Fuel which spills out could be ignited. Switch off the fuel-driven heater before starting to refuel.

Check on the information display that the parking heater is switched off. When it is running, the information display shows **PARK HEAT ON**.

Parking on a hill

If the car is parked on a steep hill, the front of the car should point downhill to ensure that there is a supply of fuel to the parking heater.

Battery and fuel

If the battery has insufficient charge or the fuel level is too low, the parking heater is switched off automatically and a message appears on the information display.

- Acknowledge the message by pressing the indicator stalk **READ** button once.

IMPORTANT

Repeated use of the parking heater combined with short journeys may discharge the battery and impair starting.

The car should be driven for the same time as the heater is used to ensure that the car's battery is recharged adequately to replace the energy consumed by the heater when it is used on a regular basis.



Fuel-driven engine block heater and passenger compartment heater*

Activating the heater

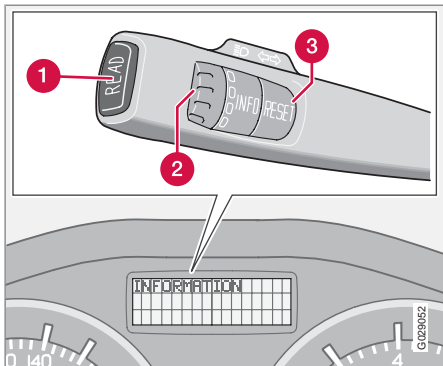

- 1 **READ** button
- 2 Thumbwheel¹
- 3 **RESET** button¹

Symbols and display messages



When one of the timer's settings or **DIRECT START** is activated, the information symbol in the combined instrument panel illuminates and the information display shows an explanatory text.

Display	Specification
FUEL HEATER ON	The heater is switched on and running.
TIMER IS SET FOR FUEL HEATER	Reminder that the heater will start at the set time after the car has been left, when the remote control key is removed from the ignition switch.

Display	Specification
HEATER STOPPED - LOW BATTERY	The heater has been stopped by the car's electronics in order to facilitate starting the engine.
HEATER STOPPED LOW FUEL LEVEL	The heater has been stopped by the car's electronics in order to facilitate starting the engine as well as 50 km driving.

Direct start and immediate stop

1. Scroll with the thumbwheel to **DIRECT START**.
2. Press the **RESET** button to select between **ON** and **OFF**.

ON: Parking heater switched on manually or with programmed timer.

OFF: Parking heater switched off.

With the direct start of the heater it will be activated for 50 minutes.

¹ No function in cars without trip computer, fuel-driven parking heater as well as stability and traction control system.

* Option/accessory, for more information, see Introduction.



Fuel-driven engine block heater and passenger compartment heater*

Heating of the passenger compartment will begin as soon as the engine coolant has reached the correct temperature.

NOTE

The car can be started and driven while the parking heater is running.

Setting the timer

The time when the car shall be used and heated is specified with the timer.

Select between **TIMER 1** and **TIMER 2**.

1. Scroll with the thumbwheel to **PARK HEAT TIMER 1**.
2. Briefly press the **RESET** button so that the hours setting starts to flash.
3. Select the required hour using the thumbwheel.
4. Briefly press **RESET** to move to the flashing minutes setting.
5. Select the required minute using the thumbwheel.
6. Briefly press **RESET** to confirm the setting.
7. Press **RESET** to activate the timer.

After setting **TIMER 1** a second start time can be programmed with **TIMER 2** by scrolling with the thumbwheel.

Set the alternative time in the same way as **TIMER 1**.

Deactivating a timer-started heater

A timer-started heater can be switched off manually before the set time has elapsed. Proceed as follows:

1. Press the **READ** button.
2. Use the thumbwheel to scroll to the text **PARK HEAT TIMER 1** or **PARK HEAT TIMER 2**.

The text **ON** flashes on the display.

3. Press **RESET**.

The text **OFF** is shown with a constant glow and the heater is switched OFF.

A timer-started heater can be switched off in accordance with the instructions in the section "Direct start and immediate stop".

Clock/timer

The heater's time is connected to the car's clock.

NOTE

All timer programming will be cleared if the car's clock is reset.



Fuel-driven auxiliary heater* (diesel)

Auxiliary heater (diesel)

In diesel-engined cars the auxiliary heater may be required for achieving the correct temperature in the engine and passenger compartment during cold weather.

The heater starts automatically when extra heat is required when the engine is running.

The heater is switched off automatically when the correct temperature is reached or when the engine is switched off.



NOTE

The auxiliary heater cannot be switched on or off manually but is only controlled by the car's electronics.

When the auxiliary heater is active there may be smoke from underneath the car, which is perfectly normal.



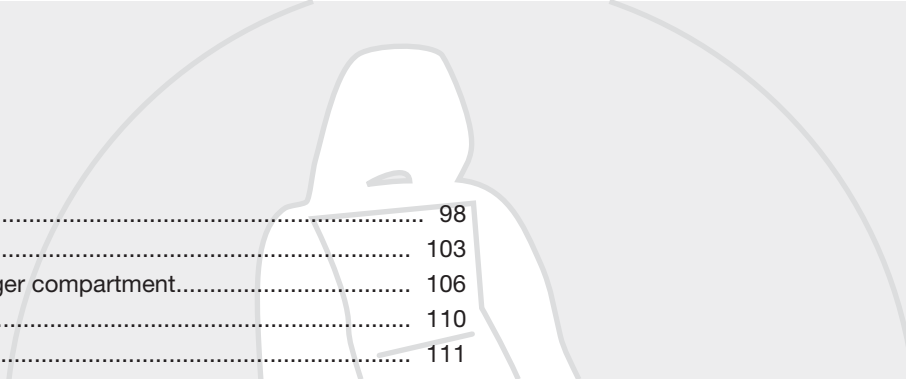

Front seats.....	98
Interior lighting.....	103
Storage spaces in the passenger compartment.....	106
Rear seat.....	110
Cargo area.....	111

INTERIOR



04





Front seats

Seating position



The driver's and passenger seats can be adjusted to the optimum sitting and driving positions.

- 1 Forward/backward: lift the handle to adjust the distance to the steering wheel and pedals. Check that the seat is locked after changing the position setting.
- 2 Raise/lower front edge of seat cushion, pump up/down.
- 3 Raise/lower the seat, pump up/down.
- 4 Lumbar support¹, turn the wheel.

5 Backrest rake: turn the wheel.

6 Control panel for power seat*.

Lever (2) is not available on all seat models.

WARNING

Adjust the position of the driver's seat and adjust the seatbelt, see page 16, before setting off, never while driving.

Check that the seat is locked in position.

NOTE

When putting on the seatbelt it is easiest to pick it up from down at the seatbelt guide, not over the shoulder.

Entry to the rear seat

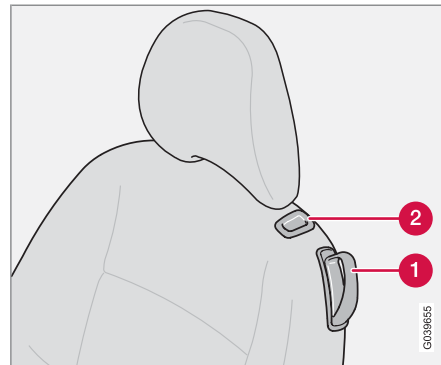

1 Handle for lowering the backrest

2 Button for moving the power seat longitudinally

NOTE

No one may sit in the seat when it is pushed forward for entry into the rear seat.

¹ Also applies to power seat.



Front seats

Manual seat

i NOTE

Lower the seat before it is pushed forward - otherwise there is a risk that the head restraint makes contact with the sun visor.

Push the seat forward:

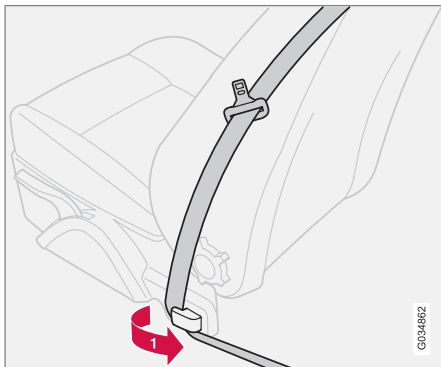

- i** Release the seatbelt from the seatbelt guide, see also page 18.



- 2** Lift the handle
- 3** Fold the backrest forward to the locked position.
4. Push the seat forward.

Push the seat backward:

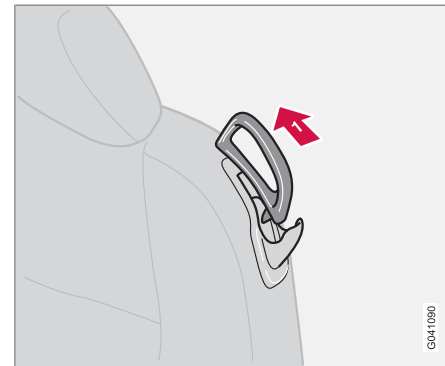

- 1** Lift the handle and fold back the backrest.
2. Push the seat backward.
3. Adjust the seat longitudinally.
4. Refit the seatbelt in the seatbelt guide.

Position memory

If the seat does not return to the same position, as before it was folded for entry, after having been pushed back - then reset the position memory as follows:

1. Sit down in the seat.
2. Lift the handle (1), see page 98, and push the seat to the rear end position



Front seats

- Continue to lift of the handle, and push the seat forward to the desired position and release the handle.

Power seat*

Push the seat forward:

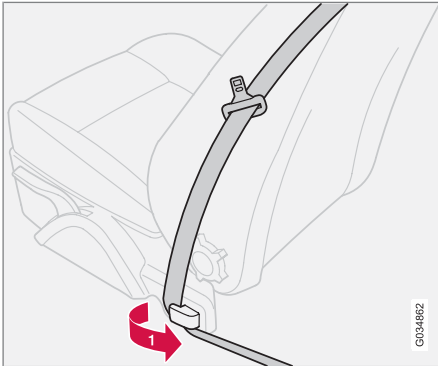

- Release the seatbelt from the seatbelt guide, see also page 18.

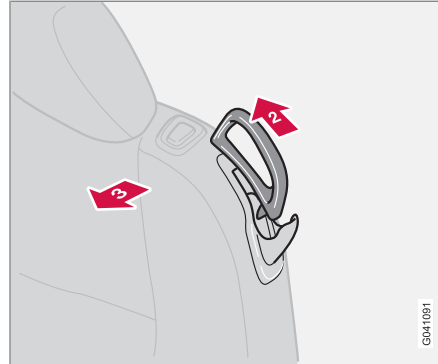

- Lift the handle.
- Fold the backrest forward to the locked position.

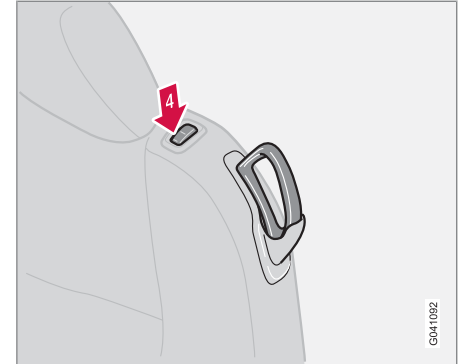

- Hold down the front section of the button.
If the seat is set in a higher position - then it will be lowered automatically to avoid the head restraint making contact with the sun visor.



Front seats

Push the seat backward

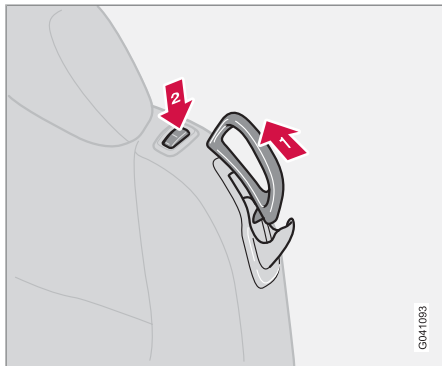

- 1 Lift the handle and fold back the backrest.
- 2 Hold down the rear section of the button.
- 3 Refit the seatbelt in the seatbelt guide.

NOTE

The seat can only be moved to the very front (+6 cm) to facilitate entry and exit to and from the rear seat when the backrest has been folded forward. If the backrest is folded back when the seat is in the front position then the seat automatically moves back approx. 6 cm after a few seconds.

WARNING

Check that the backrest is properly folded back by pushing and pulling the head restraint.

The belt on the front passenger side must be in the belt guide during driving, even when there is no passenger sitting in the seat.

Floor mats*

Volvo supplies floor carpets which are especially produced for your car.

WARNING

The floor mat at the driver's seat must be firmly fitted and secured in the attachment clips to prevent it from being trapped around and under the pedals.

Power seat*

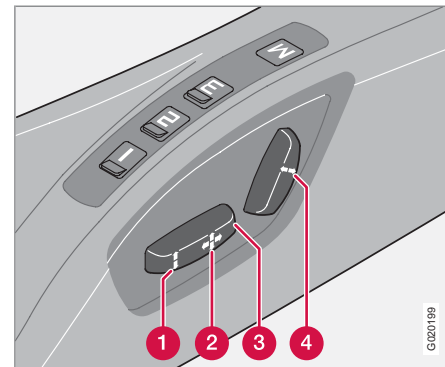

The seats can be adjusted for a certain time after unlocking the door with the remote control key without the key being inserted into the ignition switch. The seat can always be adjusted in ignition position I or II.

- 1 Front edge of seat cushion up/down
- 2 Seat, forwards/backwards
- 3 Seat, up/down
- 4 Backrest rake

An overload protection is deployed if one of the seats is blocked. If this happens, turn off the ignition and wait a short time before adjusting



Front seats

the seat again. Only one of the seat's settings can be adjusted at a time.

Memory function

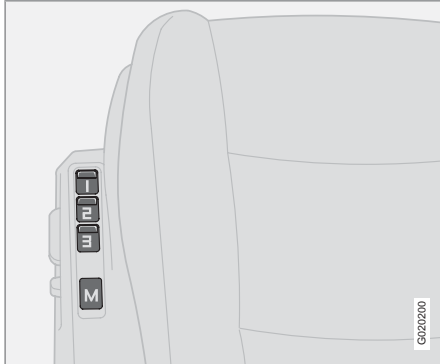

Buttons for memory function.

Store setting

1. Adjust seat.
2. Press and hold button **M** while pressing button **1**, **2** or **3** simultaneously.

Using a stored setting

Press one of the memory buttons **1–3** until the seat stops. If you release the button then the movement of the seat will stop.

Emergency stop

If the seat accidentally begins to move, press any of the buttons to stop the function.



WARNING

Risk of crushing. Make sure that children do not play with the controls.

Check that there are no objects in front of, behind or under the seat during adjustment.

Ensure that none of the rear seat passengers is in danger of becoming trapped.

Memory in remote control key

The settings for the driver's seat are stored in the memory for the remote control key with which the car is locked. When the car is unlocked with the same remote control key the driver's seat adopts the stored settings when the driver's door is opened.



NOTE

The remote control key memory is independent of seat memory.



Interior lighting

Reading lamps and interior lighting

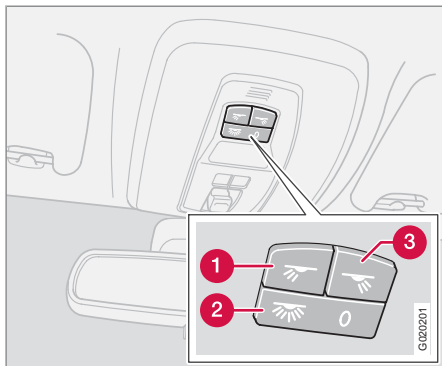

Controls in roof console for front reading lamps and passenger compartment lighting.

- 1 Reading lamp left-hand, On/Off
- 2 Interior lighting
- 3 Reading lamp right-hand, On/Off

All lighting in the passenger compartment can be switched on in ignition position **I** and **II** as well as when the engine is running. The lighting can also be activated within 30 minutes after:

- the engine has been switched off and the ignition is in position **0**
- the car has been unlocked but the engine has not been started.

Roof lighting

The reading lamps are switched on or off by pressing the relevant button in the roof console.

Courtesy lighting

Courtesy lighting (and passenger compartment lighting) is switched on and off respectively when a side door is opened or closed.

Vanity mirror*

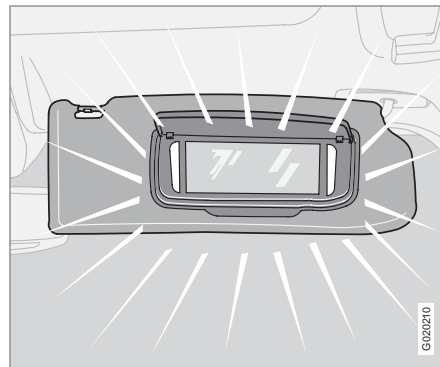

The lamp is automatically switched on and off respectively when the cover is opened or closed.

Glovebox lighting

Glovebox lighting is switched on and off respectively when the lid is opened or closed.

Cargo area lighting

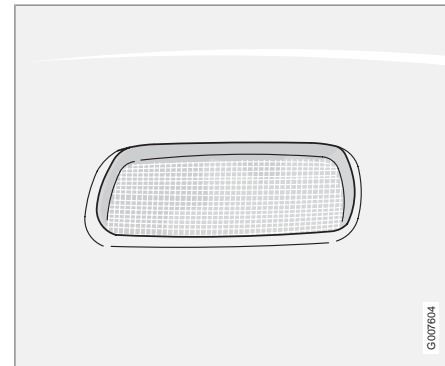

Passenger compartment lighting in rear seat and cargo area.

Apart from the passenger compartment lighting the cargo area has a further lamp on its left-hand side.

The lighting in the passenger compartment and cargo area is switched on and off respectively when the tailgate is opened or closed.



Interior lighting

Automatic lighting

Using the switch (2), see page 103, three positions can be selected for the lighting the passenger compartment:

- Off – right-hand side (marked with **0**) depressed, automatic lighting switched off.
- Neutral position – automatic lighting activated. The dimmer function is active.
- On – left-hand side depressed, passenger compartment lighting on.

Neutral position

When the switch (2) is in neutral position passenger compartment lighting is switched on and off automatically in accordance with the below.

The passenger compartment lighting is switched on and remains on for 30 seconds if:

- the car is unlocked with the remote control key or key blade.
- the engine is stopped and the remote control key is turned to position **0**.

Passenger compartment lighting is switched off when:

- the engine is started
- the car is locked with the key or remote control key.

Passenger compartment lighting comes on and remains on for 5 minutes if one of the doors is open.

If any lighting is switched on manually and the car is locked then it will be switched off automatically after 5 minutes.



Interior lighting



Storage spaces in the passenger compartment

Storage spaces

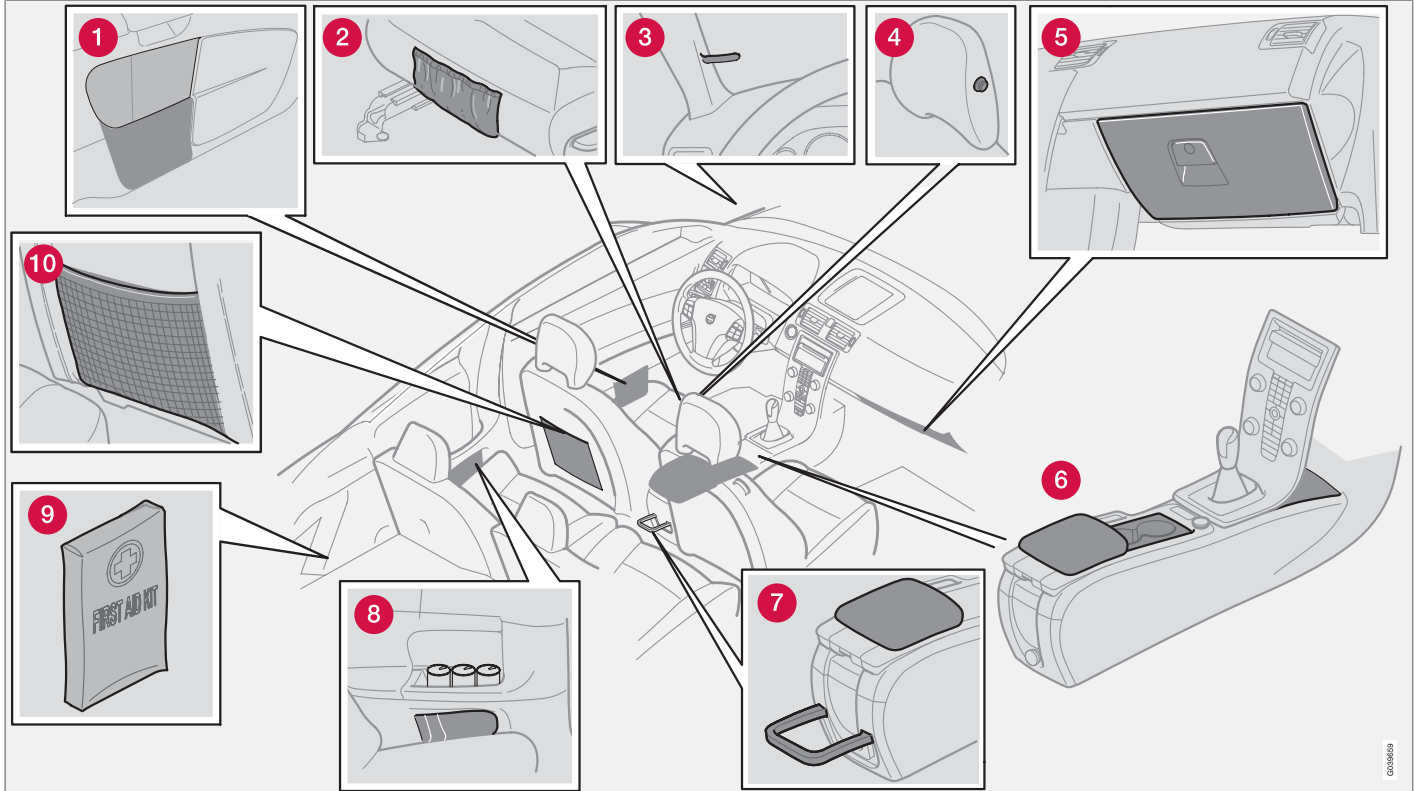



Storage spaces in the passenger compartment

- 1 Storage compartment in door panel.
- 2 Storage pocket on front edge of front seat cushions (trim dependent).
- 3 Ticket clip
- 4 Coat hanger, only for light garments.
- 5 Glovebox
- 6 Storage compartment (e.g. for CD discs and cup holder, *) and storage compartment behind the centre console.
- 7 Bottle holder*
- 8 Storage compartments in rear side panels with space for up to three soda cans.
- 9 Storage compartment for first aid.
- 10 Storage pockets for maps and magazines.

WARNING

Ensure that no hard, sharp or heavy objects lie or protrude in such a way that they could cause injury during heavy braking.

Always secure large and heavy objects with a seatbelt or cargo retaining straps.

Glovebox

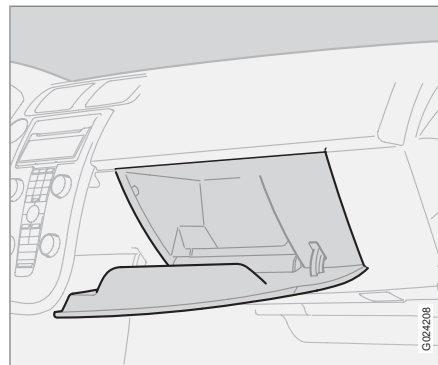

The owner's manual and maps can be kept here for example. There are also holders for coins, pens and fuel cards.

The glovebox can be locked with the remote control key's detachable key blade. Further information is available on page 117.

Coat hanger

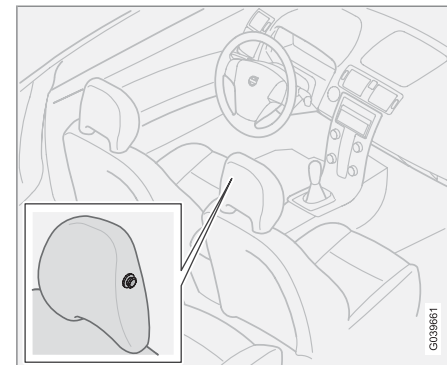

The coat hanger is located on the passenger seat head restraint. Only hang light garments on the hanger.



Storage spaces in the passenger compartment

Storage under the front armrest

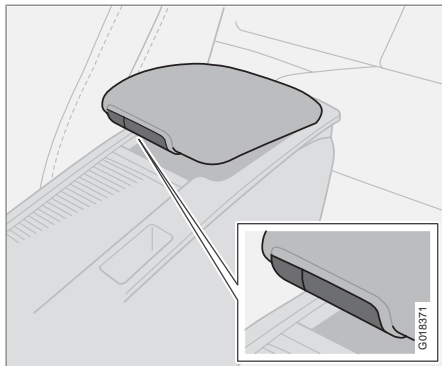

There is a storage space under the armrest. There is also a smaller storage space in the detachable armrest. Press the small button and lift the armrest to open the shallow compartment. Press the large button and lift the armrest to open the deeper compartment.

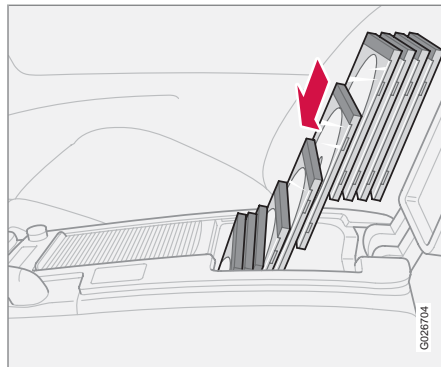

In the deeper compartment there is space for 10 normal CD cases. The cases must be stored vertically on the top edge for all 10 to have space.

Cup holder in centre console

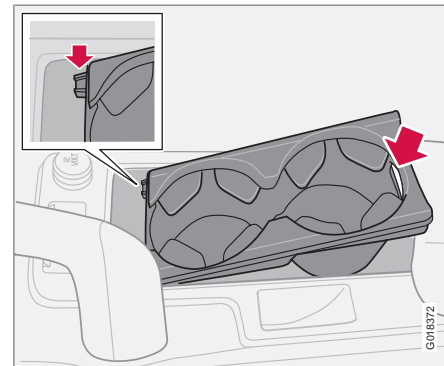

There is space for a double cup holder under the roller cover. The space can be used for storage by lifting out the cup holder. Lift at the rear edge of the cup holder where there is a recess.

If the cup holder is being fitted - first align its two guide lugs in the two recesses in the front edge of the space and then press down the rear edge of the cup holder.

Close the roller cover by gripping its front edge from below and pulling forward.



Storage spaces in the passenger compartment

Storage compartment behind the gear lever

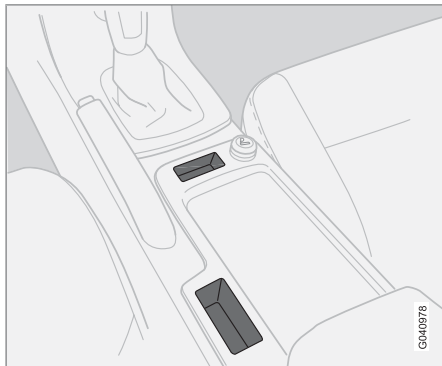

When there are no buttons for parking assistance and BLIS, see page 150 and page 152, the space can be used as a storage compartment.

Bottle holder*



A bottle holder for larger bottles is located on the rear of the tunnel console.

Ashtray*

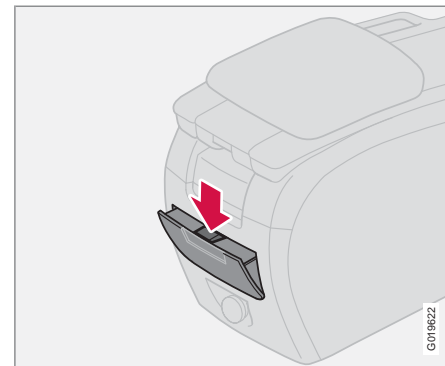

An ashtray is located towards the rear of the tunnel console.

Open the ashtray by pulling the top edge of the cover.

Emptying the ashtray:

1. Press in the catch, see preceding illustration, and tilt the cover up.
2. Then lift the ashtray out.



Rear seat

Lowering the rear seat backrest

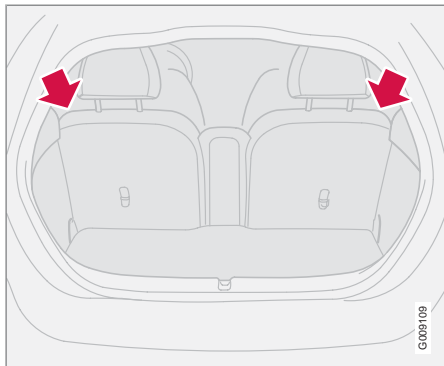

The rear seat backrests can be tipped forwards together, or individually, to make it easier to transport long objects.

Lowering the backrest

1. Pull the lock catch up and forward to release the backrest. A red indicator (A) shows that the backrest is no longer locked in place.
2. Fold the backrest forward.

Raising the backrest

1. Fold up the backrest.
2. Place the seatbelt over the backrest.

3. Press the backrest backwards into locked position.
4. Check that the backrest is locked.

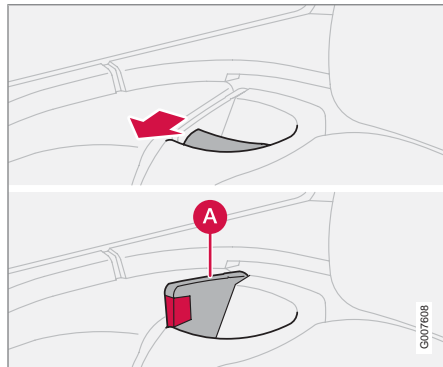

WARNING

Place the belt straps over the backrests before folding them back to their secured positions.

NOTE

When the backrest has been raised, the red indicator (A) should no longer be showing. If it is still showing then the backrest is not locked in place.

Armrest in the rear seat

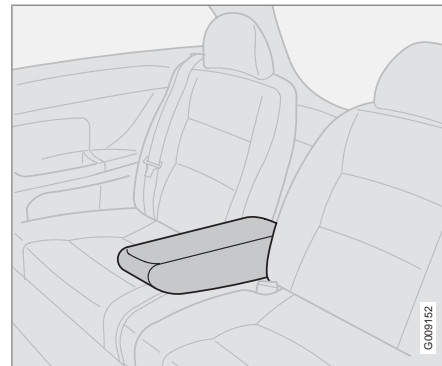

The armrest in the rear seat can be folded down for passenger comfort or to make space for a long load. The armrest folds down when one of the backrests is folded down.

For securing loads, see page 167.



Cargo area

Soft cargo cover*

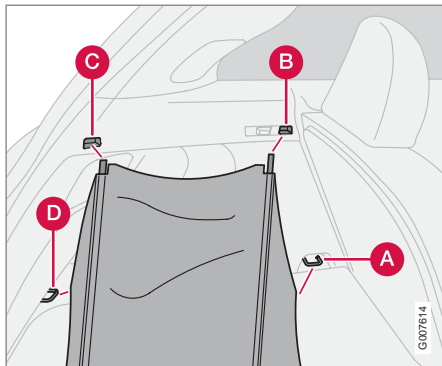

Soft cargo cover.

The cargo cover is pulled over the luggage and secured in the rear load retaining eyelets. Undo (D) and if necessary (C) during loading.

Fitting the cargo cover

1. Hook in the hooks in the front load retaining eyelets by the floor (A).
2. Fit the front brackets in (B) by pressing together the spring-loaded rail and fit it into place on both sides.
3. Fit the rear brackets in (C) in the same way.
4. Hook in the hooks in the rear load retaining eyelets (D).

Hanging up the cargo cover when not in use

1. Unhook the hooks from the rear load retaining eyelets (D).
2. Press the rail together and remove it from the rear bracket (C). Place the rail at the front of the cargo area floor.
3. Hook in the hooks in the rail next to the mounting points (B).

The cargo cover now hangs next to the rear seat backrest ready for the next time it is to be used.

Removing the cargo cover

1. Unhook the hooks and remove one rail at a time by pressing them together and removing them from their mounting points.
2. When all mounting points are detached the cargo cover can be rolled up and placed at the rear of the cargo area floor to make space for bulky loads.

 **NOTE**

The cargo cover has no load-securing function. Never load anything on top of the cargo cover. For securing loads, see page 167.

Hard cargo cover*

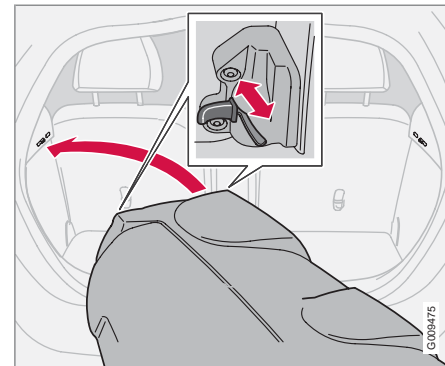

Fitting the cargo cover

1. Retract all four lock plungers by pulling the lock buttons to their end positions before lifting in the cargo cover into the cargo area. The lock plungers stop in retracted position.
2. Lift the cargo cover carefully into the cargo area sideways, turn it back around and angle the front edge up slightly.



Cargo area

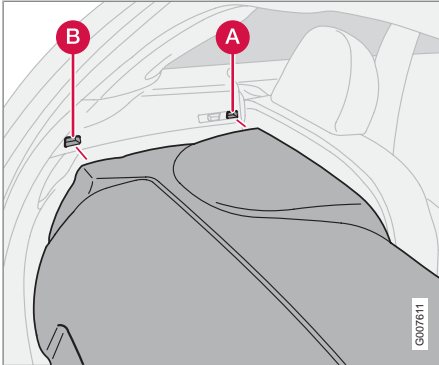

Locks and support pins.

3. Locate the front section of the two support pins behind the active locks (A) on both sides.
4. Align one of the rear locks at (B) and extend the lock plunger by moving the lock button forwards.
5. Align the other rear lock in the same way and extend the lock plunger by moving the lock button forwards.
6. Extend the front lock plungers, one at a time so that they lock in their active locks (A).

The cargo cover hatch can be raised during loading.

i NOTE

The cargo cover has no load-securing function. Never load anything on top of the cargo cover. For securing loads, see page 167.

Removing the cargo cover

1. Retract the front lock plungers at (A) to their end positions by pulling back the lock buttons on both sides.
2. Retract the rear lock plungers at (B) to their end positions by pulling back the lock buttons on both sides.
3. Lift up and turn the cargo cover before lifting it from the cargo area.

Raising the floor hatch

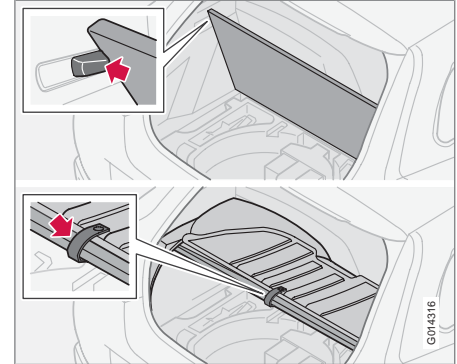

Without cargo cover

Raise the floor hatch and secure it in the lugs on both sides.

With hard cargo cover

Raise the hatch on the cargo cover. Then raise the floor hatch and hook it into the hook located under the cargo cover.



Cargo area

Safety net*

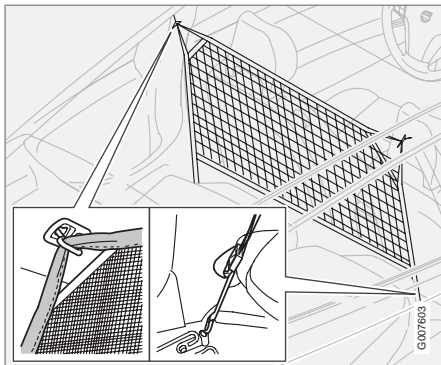

The safety net is located behind the front seat backrests. The safety net is only designed for use when the rear seat backrests are lowered. For securing loads, see page 167.

Fitting the safety net

1. Fold down the backrests on both sides, see page 110.
2. Secure the safety net in the roof panel mountings.
3. Secure the hooks in the eyes at the seatbelt floor mounting on both sides.
4. Stretch the straps if necessary.
5. Check all mountings.

Removing the safety net

1. Slacken the tension from the straps.
2. Undo the hooks from the eyes at the seatbelt floor mounting on both sides.
3. Detach the net from the mounting points in the roof panels.
4. Fold up the safety net and store it in the bag.



WARNING

Loads in the cargo area must be firmly secured even if the safety net is correctly fitted.

Load retaining eyelets*

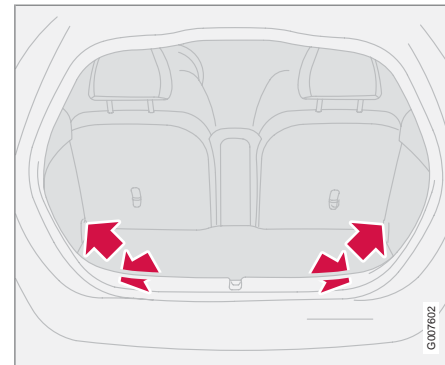

The load retaining eyelets are used to fasten straps or nets to anchor items in the cargo area.

There are two further eyelets on each side by the seatbelt slide rail that can be used for securing loads when the safety net is not in use.

For securing loads, see page 167.



Remote control key with key blade.....	116
Active locks.....	119
Keyless drive*.....	120
Battery in remote control key.....	123
Locking and unlocking.....	124
Alarm*.....	127

LOCKS AND ALARM



05



Remote control key with key blade

Remote control key

The car is supplied with two remote control keys.

The remote control keys contain detachable metal key blades for mechanical locking/unlocking of the driver's door and glovebox.

The key blades' unique code is available at authorised Volvo workshops, which are recommended for ordering new key blades.

A maximum of six remote control keys/key blades can be programmed and used for one single car.

Turn signal indication during locking/unlocking

When the car is unlocked using the remote control key or Keyless drive system, two short flashes of the direction indicators serve to indicate that unlocking was correctly performed.

For locking, the indication takes place with one long flash and only if all locks are locked, after the doors and the tailgate have been closed.

Personal preferences in the menu system can be used to deactivate the indication via the direction indicators. There will then be no visual indication as to whether the lock status is correct, see page 75.

Loss of a remote control key

If you lose a remote control key, take the car and the other remote control keys to a Volvo workshop - an authorised Volvo workshop is recommended. The code of the missing remote control key must be erased from the system as a theft prevention measure.

Immobiliser

The remote control keys are fitted with coded chips. The code must be accepted by the reader (receiver) in the ignition switch. The car can only be started if the correct remote control key with the correct code is used.

Remote control key functions

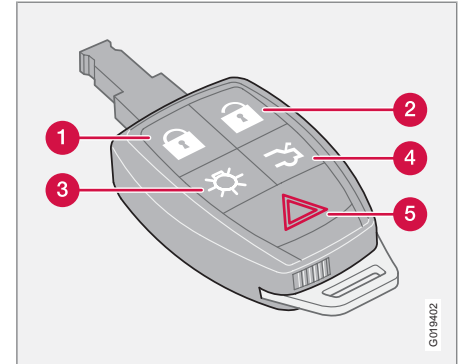

- 1 Locking** – Locks all doors and the tailgate. Press and hold to also close the side windows and sunroof.
- 2 Unlocking** – Unlocks the doors and the tailgate.
- 3 Approach lighting** – Switches on the lighting at a distance – lights up the area around a car parked in a dark location. Press the button once to switch on the interior lighting, position/parking lamps, number plate lighting and door mirror lamps (option). The lighting is switched off automatically after

G019402



Remote control key with key blade

30, 60 or 90 seconds. For information on setting the delay time, see page 75.

- 4 Tailgate** – Press the button once to unlock the tailgate only.¹
- 5 Panic function** – Used to attract attention in an emergency. Press and hold the red button for at least three seconds or press it twice within three seconds to activate the direction indicators and the horn. The function can be turned off with the same button once it has been active for at least 5 seconds. Otherwise the function switches off automatically after 30 seconds.

! IMPORTANT

The narrow section of the remote control key is particularly sensitive - this contains the chip. The car cannot be started if the chip is damaged.

Detachable key blade

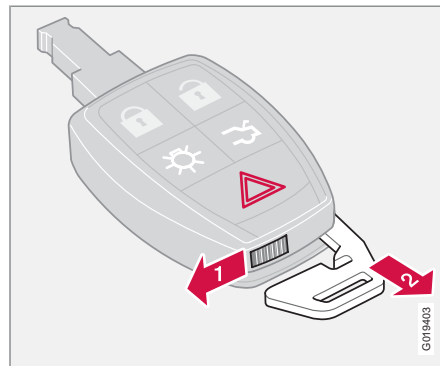

Using the remote control key's detachable key blade:

- the driver's door can be opened manually if central locking is not activated with the remote control key, see page 121.
- access to the glovebox can be blocked, see page 118.

Removing the key blade

To remove the key blade from the remote control key:

- 1** Slide the spring-loaded catch to the side.

- 2** Pull out the key blade at the same time.

Inserting the key blade

Be careful when inserting the key blade into the remote control key.

1. Hold the remote control key with the narrow end pointing down and lower the key blade into its slot.
2. Lightly press the key blade to lock it in position. You should hear a "click".

Unlocking doors with the key blade

If central locking cannot be activated with the remote control key, e.g. if the batteries are discharged, then the driver's door can be unlocked and opened as follows:

1. Insert the key blade in the driver's door keyhole.
2. Turn the blade 45 degrees clockwise and open the door.

i NOTE

When the driver's door is unlocked using the key blade and is opened, the alarm is triggered. It is switched off by inserting the remote control key in the ignition switch, see page 128.

¹ The function unlocks the boot lid – it does not open.



Remote control key with key blade

Locking the glovebox

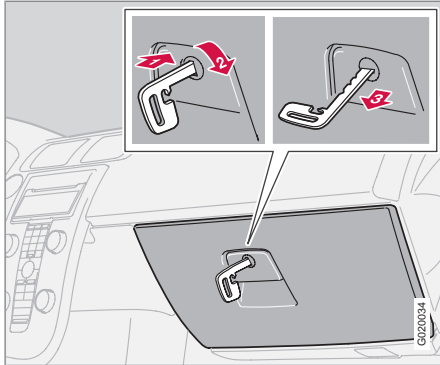

i NOTE

The remote control key cannot unlock the glovebox without the key blade.

This function is particularly useful for when the car is left for service, at a hotel or similar.

The glovebox can only be locked/unlocked using the remote control key's detachable key blade. (For information on the key blade, see page 117.)

- 1** Insert the key blade in the glovebox lock.
 - 2** Turn the key blade 90 degrees clockwise. The keyhole is horizontal in the locked position.
 - 3** Pull out the key blade.
- Unlocking takes place in reverse order.



Active locks

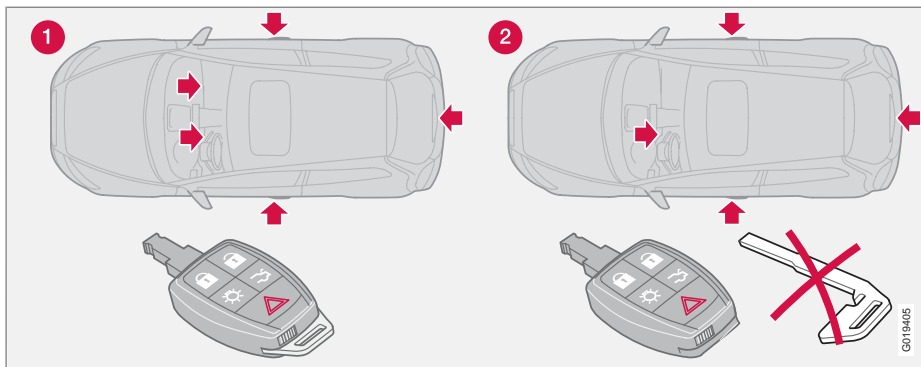

- 1 Active locks for remote control key with key blade.
- 2 Active locks for remote control key without key blade.



Keyless drive*

Keyless lock and ignition system

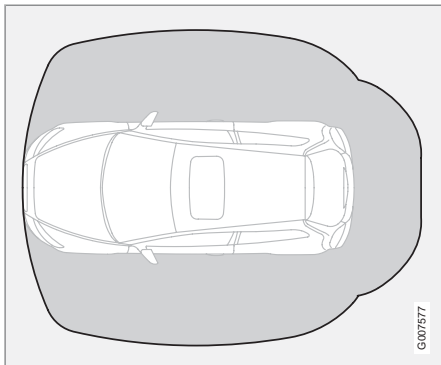

The keyless drive system allows the car to be unlocked, driven and locked without the need for a key. You simply need to have the remote control key with you in a pocket or a bag.

The system makes it easier and more convenient to open the car, for example with shopping bags in one hand and a child in the other. It saves you having to take out or look for the remote control key.

The two remote control keys incorporate the keyless drive function. You can order additional remote controls. The keyless drive system can handle up to six remote controls.

Remote control key max. 1.5 m from the car

In order to open a door or the tailgate, a remote control key must be no more than approx. 1.5 m from the car door handle or tailgate.

This means that the person who wishes to open a door must have the remote control key with him or her. It is not possible to open a door if the remote control key is on the other side of the car.

The grey area in the illustration indicates the range covered by the system's antennas.

If someone leaves the car and takes a keyless drive remote control key with them, a warning message appears on the information display and a reminder signal sounds. The warning message disappears when the remote control key is brought back to the car or when the ignition dial is turned to position **0**. The warning is only issued if the ignition dial is in position **I** or **II** after someone has opened and closed a door.

The warning message and reminder signal disappear when the remote control key is brought back to the car after one of the following actions:

- a door has been opened and closed
- the ignition dial has been turned to position **0**

- the **READ** button has been pressed.

Never leave any remote control key in the car

If a remote control key with keyless drive function is left in the car, it is made passive when the car is locked. This prevents unauthorised entry.

If someone breaks into the car and finds the remote control key, it can be activated and used again. It is therefore important to handle all remote control keys with equal care.

Interference to remote control key function

Electromagnetic screening and fields can interfere with the keyless drive system. To avoid this: do not place the remote control key near mobile phones, metallic objects or, for example, in a metal briefcase.

If interference is experienced nonetheless, use the remote control key and key blade in the normal way, see page 116.



Keyless drive*

Locking

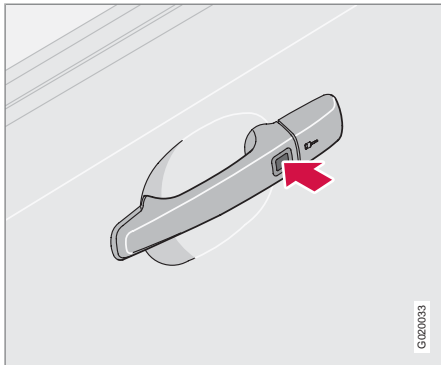

Cars with the keyless system have a button on the outside door handles.

When the remote control key is within the range covered by the system's antennas, the doors and the tailgate are locked as follows:

- Push in the lock button on one of the door handles.

All doors must be closed before the lock button is pushed in. Otherwise they will not lock.

When the car is locked, the lock buttons on the inside of the doors retract.

i NOTE

On cars with the keyless drive system and automatic transmission the gear selector must be moved to the **P** position and the ignition dial turned to the **0** position. Otherwise the car cannot be locked or alarmed.

Unlocking

When the remote control key is within the range covered by the system's antennas:

1. Open the doors by pulling the relevant handle.
2. Open the tailgate by pressing under the tailgate opening button and lift the tailgate.

If for some reason the keyless drive function in the remote control key is not operating, the car can be unlocked using the remote control key functions, see page 116.

Power seat – remote control key with memory function

If several people with keyless drive remote control keys get into the car, then the driver's seat will be adjusted for the person who opens the door first.

Unlocking doors with the key blade

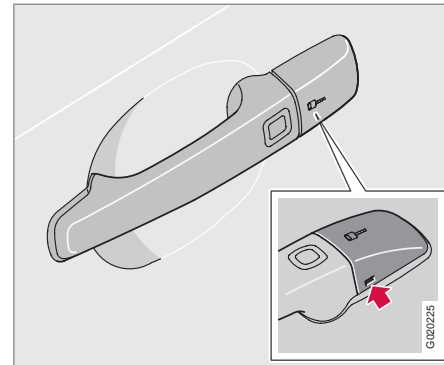

If central locking cannot be activated with the remote control key, e.g. if the batteries are discharged, then the driver's door can be opened as follows:

1. To access the keyhole: Carefully prize out the plastic cover in the handle by inserting the key blade in the hole on the bottom of the cover.
2. Unlock the door using the key blade.



Keyless drive*

NOTE

When the driver's door is unlocked using the key blade and is opened, the alarm is triggered. It is switched off by inserting the remote control key in the ignition switch, see page 128.

Antenna location

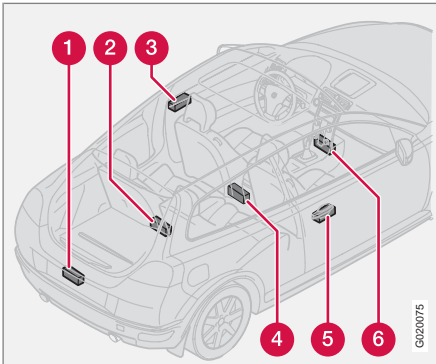

The keyless system has a number of integrated antennae located around the car:

- 1 Rear bumper, inside centre
- 2 Cargo area, central and furthest in under the floor
- 3 Door handle, left

- 4 Centre console, under the rear section
- 5 Door handle, right-hand rear
- 6 Centre console, under the front section

WARNING

People with pacemaker operations should not come closer than 22 cm to the keyless system's antennae with their pacemaker. This is to prevent interference between the pacemaker and the keyless system.

Personal preferences

The Keyless Drive system can have personal preferences applied, see page 75.

* Option/accessory, for more information, see Introduction.



Battery in remote control key

Low battery in remote control key

When the battery runs down and full functionality cannot be guaranteed, the information symbol  and display show **KEY BATTERY LOW VOLTAGE** or **CAR KEY - CHANGE BATTERY**.

Changing the remote control key battery

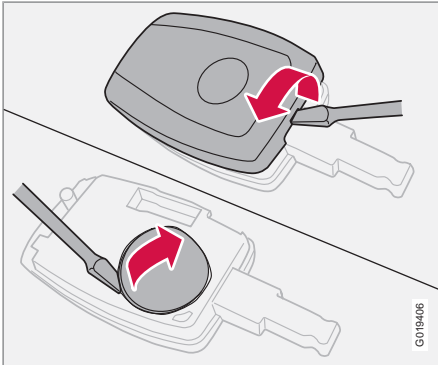

1. Place the remote control key with the keypad downward and prize up the cover using a small screwdriver.
2. Remove the cover.
3. Carefully examine how the battery's (+) and (-) sides are fitted (there is a diagram under the cover).
4. Prize out and change the battery. Avoid touching the battery and its terminals with your fingers.
5. Refit the cover and press it in.

Dispose of the old battery in an environmentally-responsible manner.

If the locks repeatedly fail to respond to signals from the remote control key at a normal distance, the battery should be replaced (type CR 2450, 3 V).



Locking and unlocking

Locking/unlocking the car from outside

For cars with the Keyless system, see page 120.

Unlocking

Using the remote control key's unlock button the car can be unlocked in two different ways (select in personal settings, see page 75):

- One press unlocks the doors and the tailgate
- One press unlocks the driver's door and a second press unlocks the other doors and the tailgate.

Locking

The remote control key lock button locks the doors and the tailgate at the same time - the doors' lock button and door handles on the inside are disengaged*.

NOTE

The car can be locked even if the tailgate is open - when the tailgate is then closed there is a risk that the keys will be locked in*.

WARNING

Be aware that you can be locked in the car if it is locked from the outside with the remote control key. You cannot then leave the car using any of the controls inside the car.

Rapid closing

Press and hold (at least 4 seconds) on the remote control key's lock button to close all windows and sunroof* at the same time.

Different personal settings can be made, see page 75.

Tailgate

Unlocking

Unlocking tailgate only:

- Press the remote control key's button to unlock the tailgate.

Locking

If the doors are locked when the tailgate is closed then it remains unlocked. Lock with the remote control key's lock button or from inside to lock both doors and the tailgate.

Automatic relocking

If none of the doors or the tailgate is opened within 2 minutes of unlocking, all are locked again automatically (does not apply to locking from inside). This function reduces the risk of the car being left unlocked unintentionally. (For cars with alarms, see page 128.)

Locking/unlocking the car from inside

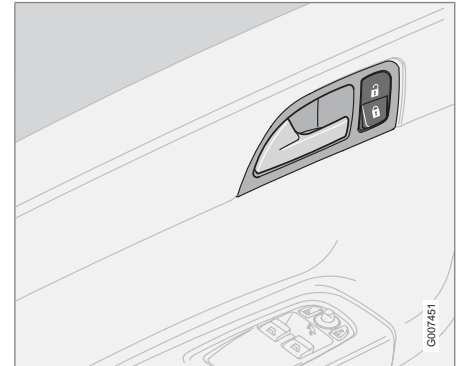

The doors and the tailgate can be locked or unlocked simultaneously using the central locking button on either front door.

0A07/451



Locking and unlocking

Unlocking

- Press the upper section of the central locking button .

A long press (at least 4 seconds) also opens all the side windows simultaneously - for example, to quickly ventilate the passenger compartment during hot weather.

Locking

- Press the lower section of the central locking button .

Press and hold (at least 4 seconds) to also close all windows and the sunroof* at the same time.

Opening the doors

When the doors are locked from the inside:

- Pull the handle twice to unlock and open the door.

Automatic locking

When the speed of the car exceeds 7 km/h the doors and tailgate are locked automatically.

When the function is activated and the doors have been locked they can be opened in two ways:

- Pull one of the door handles twice
- Press the upper section of the central locking button  and pull the door handle.

The function can be activated/deactivated by means of personal preferences, see page 75.

Deadlocks*

When deadlocked, the doors cannot be opened from the inside if they are locked with the remote control key.

The deadlocks are activated with the remote control key and are set after a 25 second delay after the doors are locked.

The car can only be unlocked from a deadlock state with the remote control key. The driver's door can also be unlocked with the detachable key blade.

Temporary deactivation

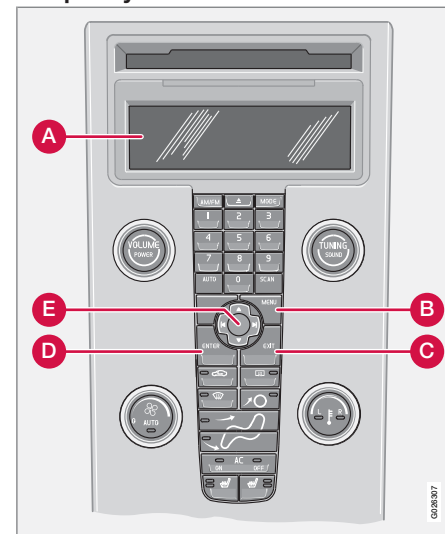

Active menu options are indicated with a cross.

- A** Display
- B** MENU
- C** EXIT
- D** ENTER
- E** Navigation



Locking and unlocking

If someone is going to stay in the car but the doors must be locked from the outside, then the deadlocks function can be temporarily switched off.

This is carried out as follows:

1. Access the menu system under **Car settings** (for a detailed description of the menu system, see page 75).
2. Select **Reduced guard**.
3. Select **Activate once**: The instrument panel display shows the message **Reduced guard - See manual** and the deadlocks function is switched off when the car is locked.

or

Select **Ask on exit**: Each time the key is turned to position **0** the audio system display shows the message **Press ENTER to reduce guard until engine is started**.

EXIT to cancel - select one of the options:

- If the deadlocks function shall be switched off: Press **ENTER** and lock the car.

If the car is equipped with an alarm with movement and tilt detectors* then these are switched off at the same time, see page 128.

The next time the remote control key is turned to key position **II** the system is reset to zero and the instrument panel display shows the mes-

sage **Full guard** at which the deadlocks function and the alarm's movement and tilt detectors* are re-engaged.

or

- If the locking system shall not be changed: Select no options at all and lock the car. Or press **EXIT** and lock the car.



NOTE

If the car is equipped with an alarm:

- Remember that the car's alarm is armed when the car is locked.
- If any of the doors are opened from the inside then the alarm will be triggered.



WARNING

Do not allow anyone to remain in the car without first deactivating the deadlocks to avoid the risk of anyone being locked in.

**Alarm*****Alarm system**

When the alarm is armed, it continually monitors all alarm inputs.

The alarm is triggered if:

- a door, the bonnet or tailgate opens
- a non-approved key is used in the ignition or if an attempt is made to force the lock
- a movement is detected in the passenger compartment (if fitted with a movement detector)
- the car is raised or towed away (if fitted with a tilt detector)
- the battery's cable is disconnected
- anyone tries to disconnect the siren
- the rear window is broken.

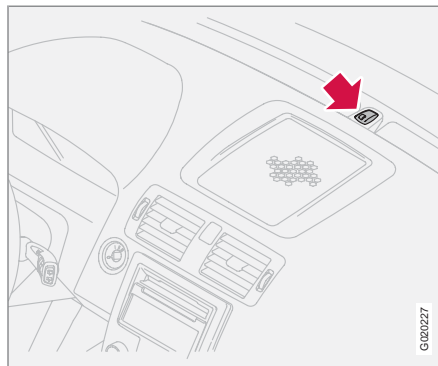
Alarm indicator

A red LED on the instrument panel indicates the alarm system's status:

- LED not lit – the alarm is not armed.
- The LED flashes once every other second – Alarm is armed.
- The LED flashes rapidly after disarming the alarm and until key position II is activated – the alarm has been triggered.

If there is a fault in the alarm system, a message appears on the display. At which point you should contact a workshop - an authorised Volvo workshop is recommended.

NOTE

Do not attempt to repair or modify alarm system components. All such attempts could affect the terms of insurance.

Arming the alarm

- Press the remote control key lock button. A long flash from the car's direction indicators confirms that the alarm is armed and that the doors are locked.

IMPORTANT

The alarm is fully armed when the car's direction indicators have made one long flash and the LED on the instrument panel flashes once every other second.

Disarming the alarm

- Press the remote control key unlock button. Two short flashes from the car's direction indicators confirm that the alarm is disarmed and that the doors are unlocked.



Alarm*

Automatic re-arming of the alarm

This function prevents you accidentally leaving the car without the alarm on.

If none of the doors or the tailgate are opened within two minutes of disarming the alarm (and the car has been unlocked with the remote control key), the alarm is automatically rearmed. The car is locked at the same time.

Deactivating a triggered alarm

- Press the unlock button on the remote control key or insert the key in the ignition switch.

Confirmation is given by two short flashes from the direction indicators.

Alarm signals

When the alarm is triggered, the following happens:

- A siren sounds for less than 25 seconds. The siren has its own battery which is used if the car battery has insufficient charge or is disconnected.
- The direction indicators flash for 5 minutes or until the alarm is deactivated.

Remote control key not working

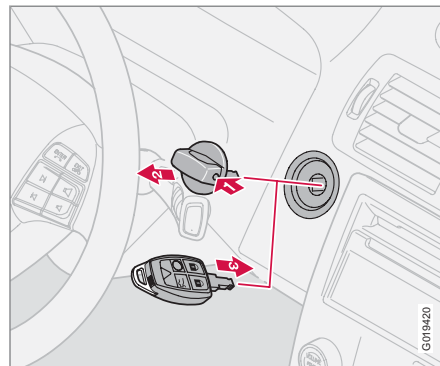

If for some reason the remote control key is not working, the alarm can still be switched off and the car started as follows:

1. Open the driver's door with the key blade. The alarm is triggered and the siren sounds.
2. On cars with the keyless drive system: First remove the knob by pressing in the catch (1) and pulling out (2).
3. Insert the remote control key in the ignition switch (3). The alarm is deactivated. The alarm light flashes rapidly until the remote control key is turned to key position II.

Reduced alarm level

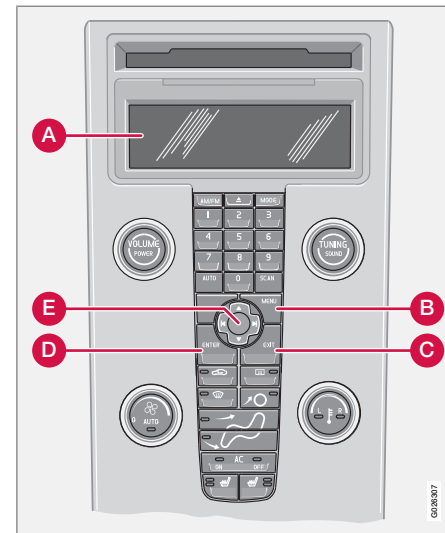

Active menu options are indicated with a cross.

- A** Display
- B** MENU
- C** EXIT
- D** ENTER
- E** Navigation

**Alarm***

To avoid inadvertently triggering of the alarm - for example when leaving a dog in the car or during a ferry crossing - the movement and tilt detectors can be temporarily switched off.

This is carried out as follows:

1. Access the menu system under **Car settings** (for a detailed description of the menu system, see page 75).
 2. Select **Reduced guard**.
 3. Select **Activate once**: The instrument panel display shows the message **Reduced guard - See manual** and the movement and tilt detectors are switched off when the car is locked.
- or

Select **Ask on exit**: Each time the key is turned to position **0** the audio system display shows the message **Press ENTER to reduce guard until engine is started. EXIT to cancel** - select one of the options:

- If the movement and tilt detectors shall be deactivated: Press **ENTER** and lock the car.

If the car is equipped with the deadlocks function then it is switched off at the same time, see page 125.

The next time the remote control key is turned to key position **II** the system is reset to zero and

the instrument panel display shows the message **Full guard** at which the movement and tilt detectors and the deadlocks function are re-engaged.

or

- If the detectors shall not be switched off: Select no options at all and lock the car. Or press **EXIT** and lock the car.

Testing the alarm system**Testing the movement detector in the passenger compartment**

1. Open all the windows.
2. Arm the alarm. Activation of the alarm is confirmed by the lamp flashing slowly.
3. Please wait 30 seconds.
4. Test the movement detector in the passenger compartment, such as by lifting out a bag from a seat. A siren should sound and all direction indicators should flash.
5. Deactivate the alarm by unlocking the car with the remote control key.

Test of alarm for doors

1. Arm the alarm.
2. Please wait 30 seconds.
3. Unlock the driver's door with the key blade.

4. Open one of the doors. A siren should sound and all direction indicators should flash.
5. Deactivate the alarm by unlocking the car with the remote control key.

Test of alarm for bonnet

1. Sit in the car and deactivate the movement detector.
2. Arm the alarm. Remain in the car and lock the doors with the button on the remote control key.
3. Please wait 30 seconds.
4. Open the bonnet with the handle under the dashboard. A siren should sound and all direction indicators should flash.
5. Deactivate the alarm by unlocking the car with the remote control key.

General.....	132
Refuelling.....	134
Starting the engine.....	135
Starting the engine – Flexifuel.....	137
Keyless drive*.....	139
Manual gearbox.....	140
Automatic gearbox.....	142
Brake system.....	146
DSTC – Stability and traction control system*.....	148
Park Assist*.....	150
BLIS* – Blind Spot Information System.....	152
Towing and recovery.....	156
Start assistance.....	158
Driving with a trailer.....	159
Towing equipment*.....	161
Detachable towbar*.....	163
Loading.....	167
Adjusting headlamp pattern.....	168

STARTING AND DRIVING



06



General

Economical driving

Driving economically means driving smoothly while thinking ahead and adjusting your driving style and speed to the prevailing conditions. For more advice on reducing environmental impact, see page 12.

- Get the engine warmed up as soon as possible.
- Do not let the engine idle, but drive at light loads as soon as it is possible.
- A cold engine consumes more fuel than a warm one.
- Avoid braking too hard.
- Do not drive with unnecessary loads in the car.
- Do not use winter tyres when the roads are dry.
- Remove load carriers when they are not being used.
- Avoid driving with open windows.

Slippery driving conditions

Practise driving on slippery surfaces under controlled conditions to learn how the car reacts.

Engine and cooling system

Under special conditions, for example when driving in hilly terrain, extreme heat or with heavy loads, there is a risk that the engine and cooling system will overheat.

Avoid overheating the cooling system

- Maintain a low speed when driving with a trailer up long, steep ascents.
- Do not turn the engine off immediately you stop after a hard drive.
- Remove any auxiliary lamps from in front of the grille if driving in extreme high temperatures.

Avoid overheating the engine

Do not exceed engine speeds of 4500 rpm (diesel engines: 3500 rpm) if driving with a trailer or caravan in hilly terrain. The oil temperature could then become too high.

Open tailgate

Avoid driving with the tailgate open. If it is necessary to drive with the tailgate open for a short distance:

1. Close all windows.
2. Set the air distribution to the windscreen and floor and run the fan at high speed.



WARNING

Do not drive with the tailgate open. Toxic exhaust fumes can be drawn into the car through the cargo area.

Driving in water

The car can be driven through water at a maximum depth of 25 cm at a maximum speed of 10 km/h. Extra caution should be exercised when passing through flowing water.



IMPORTANT

Engine damage can occur if water enters the air filter.

In greater depths, water can enter the transmission. This reduces the lubricating ability of the oils and shortens the service life of the systems.



When driving in water, maintain a low speed and do not stop the car. When the water has been passed, depress the brake pedal lightly and check that full brake function is achieved. Water and mud for example can make the brake linings wet resulting in delayed brake function.

Clean the electric contacts of the electric engine block heater and trailer coupling after driving in water and mud.

IMPORTANT

Do not let the car stand with water over the sills for any long period of time. This could cause electrical malfunctions.

In the event of stalling in water, do not try to restart. Tow the car from the water.

Do not overload the battery

The electrical functions in the car load the battery to varying degrees. Avoid having the remote control key in position II when the engine is switched off. Use key position I instead, as less power is consumed.

Note that the 12 volt outlet in the cargo area supplies power even when the remote control key has been removed from the ignition switch.

Examples of functions that use a lot of power:

- ventilation fan
- windscreen wipers
- audio equipment (high volume)
- parking lights.

Also, be aware of different accessories that load the electrical system. Do not use functions which use a lot of power when the engine is switched off.

If the battery voltage is low, a message appears on the display. The energy-saving function shuts down certain functions or reduces the load on the battery by, for example, slowing the ventilation fan and switching off the audio system.

Charge the battery by starting the engine.



Refuelling

Opening the fuel filler flap

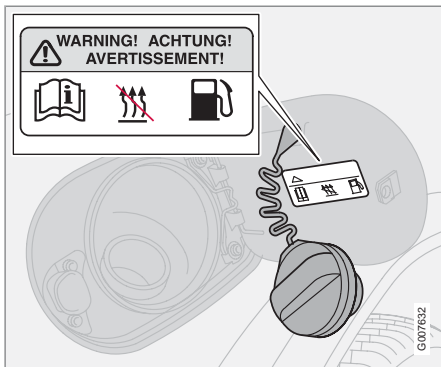

Don not forget to switch off the fuel-driven heater before refuelling!

Open the fuel filler flap with the button on the lighting panel, see page 54. The engine must be switched off before the flap can be opened. The fuel flap is located on the rear right wing.

Closing

Push in the flap until you hear a click.

Fuel cap

1. Turn the fuel cap until an obvious resistance is felt.
2. Turn past the resistance until it comes to a stop.

3. Take out the cap.
4. Hang up the cap on the inside of the fuel filler flap.

NOTE

Put the petrol cap back on after refuelling. Turn until one or more clear clicks are heard.

Filling up with fuel

Do not overfill the tank but fill until the pump nozzle cuts out.

NOTE

Excess fuel in the tank can overflow in hot weather.

Fuel of a lower quality than that specified should not be used as engine power and fuel consumption can be negatively affected, see page 275.

WARNING

Fuel which spills on to the ground can be ignited by the exhaust fumes.

Switch off the fuel-driven heater before starting to refuel.

Never carry an activated mobile phone when refuelling. The ring signal could cause spark build-up and ignite petrol fumes, leading to fire and injury.

Petrol

IMPORTANT

Do not add cleaning additives to the petrol, unless recommended by Volvo.

For more information on petrol, see page 275.

Diesel

At low temperatures (-5 °C to -40 °C), a paraffin precipitate may form in the diesel fuel, which can lead to ignition problems. For more information, see page 276.

IMPORTANT

Use special winter grade fuel during cold months.



Starting the engine

Before starting the engine

- Apply the parking brake.

Automatic gearbox

- Move the gear selector in position **P** or **N**.

Manual gearbox

Put the gear lever in neutral and hold the clutch pedal fully depressed. This is particularly important in very cold conditions.

WARNING

Never remove the remote control key from the ignition switch while driving or when the car is being towed. The steering lock could otherwise be activated, making it impossible to steer the car.

The remote control key must be in key position **II** when the car is being towed.

NOTE

The idling speed can be noticeably higher than normal for certain engine types during cold starting. This is in order that the emissions system can reach normal operating temperature as quickly as possible, which minimises exhaust emissions and protects the environment.

Starting the engine

Petrol

- Turn the remote control key to key position **III**. If the engine does not start within 5–10 seconds, release the key and try again.

Diesel

1. Turn the remote control key to key position **II**.
 - > An indicator symbol in the combined instrument panel shows that engine preheating is underway, see page 47.
2. Turn the ignition key to position **III** when the indicator symbol goes out.

Autostart (5-cylinder)

With the autostart function, there is no need to hold the remote control key (or ignition dial on cars with Keyless Drive, see page 120) in key position **III** until the engine has started.

Turn the ignition key to the start position **III** and just release it - the starter motor then works automatically until the engine has started.

NOTE

If the diesel engine is started in extreme cold without waiting for engine preheating, then the automatic start sequence can be delayed for a couple of seconds.

Key positions

0 – Locked position

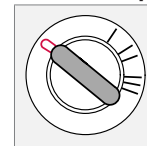

The steering lock is activated when the remote control key is removed from the ignition switch.

I – Radio position

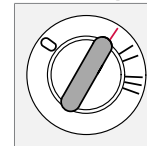

Certain electrical components can be switched on. The engine's electrical system is not activated.

II – Driving position

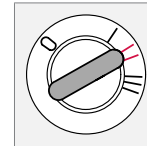

The remote control key's position when driving. The car's electrical system is energised.



Starting the engine

III – Start position

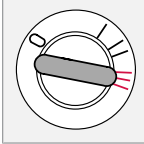

The starter motor is engaged. When the remote control key is released it springs back automatically to the driving position, once the engine has started.

A ticking sound may be heard if the key is between positions. Turn the remote control key to position II and back to eliminate the sound.

When the steering lock is activated

If the front wheels are positioned so that there is tension in the steering lock, a warning message may be shown on the information display and the car prohibited from starting.

1. Remove the remote control key from the ignition switch and turn the steering wheel so that the tension is released.
2. Hold the steering wheel in this position. Reinsert the key and make a new attempt to start the car.

WARNING

Never remove the remote control key from the ignition switch while driving or when the car is being towed. The steering lock would be activated, making it impossible to steer the car.

WARNING

Always remove the remote control key from the ignition switch when leaving the car, especially if there are children in the car.

Make sure the steering lock is activated when the car is left to reduce the risk of theft.

Remote control keys and electronic immobiliser

The remote control key must not hang with other keys or metal objects on the same key ring. The electronic immobiliser could be activated accidentally.



Starting the engine – Flexifuel

General information about starting with Flexifuel

The engine is started in the same way as in a petrol-engined car, see page 135.

i NOTE

The immobiliser is activated in the event of repeated start attempts. Before a new start attempt is made the key/dial must first be turned back to position **I** or **0**.

In the event of starting difficulties

If the engine does not start at the first start attempt, proceed as follows:

1. Depress the accelerator pedal 1/3 to 1/2.
2. Turn the remote control key/ignition dial to key position **III**.
3. When the engine has started, ease the accelerator pedal gradually as the engine speed increases.

If the engine has not started after 10 seconds, second attempt

- Turn the remote control key/ignition dial to key position **III** until the engine starts, but not longer than 60 seconds.

If the engine still does not start

- Please wait for one minute, fully depress the accelerator pedal and repeat the previous procedure.

! IMPORTANT

If the engine does not start despite repeated start attempts, contact a workshop - an authorised Volvo workshop is recommended.

Engine block heater*

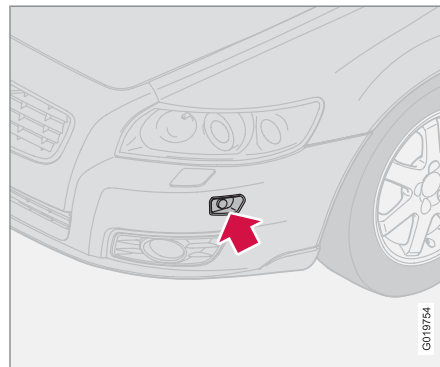

Electrical input to the engine block heater.

When the temperature is expected to be lower than -10°C and the car has been refuelled with

bioethanol E85, an engine block heater should be used for about 2 hours to facilitate the quick starting of the engine.

The lower the temperature, the longer the time required with the engine block heater. At -20°C the heater should be used for approx. 3 hours.

Cars intended for E85 have an electric engine block heater*. Starting and driving with a pre-heated engine involves significantly lower emissions and reduced fuel consumption. For this reason you should aim to use the engine block heater throughout the winter months.

! WARNING

The engine block heater is powered by high voltage. Fault tracing and repair of an electric engine block heater and its electrical connections must only be carried out by a workshop - an authorised Volvo workshop is recommended.



Starting the engine – Flexifuel

NOTE

Points to remember for carrying reserve fuel:

In the event of stalling due to an empty fuel tank, bioethanol E85 from a reserve fuel can may make the engine difficult to start in extreme cold. This is avoided by filling the reserve fuel can with 95 octane petrol.

If the battery has been discharged or disconnected then a slightly longer period of driving is required for the adaptation as the memory for the electronics has been cleared.

For more information on Flexifuel's bioethanol E85 fuel, see page 276.

Fuel adaptation

If the fuel tank is filled with petrol after the car has been driven on bioethanol E85 (or vice versa) then the engine may run slightly unevenly for a time. For this reason it is important to allow the engine to accustom itself (adapt) to the new fuel mixture.

Adaptation takes place automatically when the car is driven for a short period at an even speed.

IMPORTANT

After the fuel mixture in the tank has been changed an adaptation should be made by driving at an even speed for about 15 minutes.



Keyless drive*

General

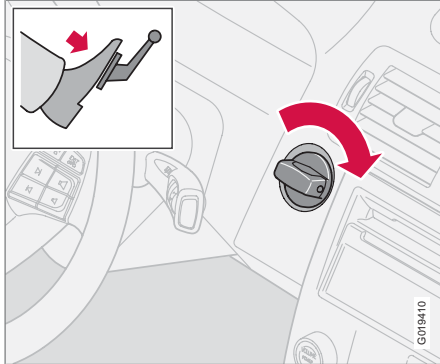

The keyless drive system allows the car to be unlocked, driven and locked without the need for a key, see page 120.

The ignition switch ignition dial is used in the same way as the remote control key. One precondition for starting the car is that the car's remote control key is located inside the passenger compartment or the cargo area.

Starting the car

- Depress the clutch pedal (cars with manual gearbox) or brake pedal (cars with automatic gearbox).

Petrol engine

- Press in and turn the ignition dial to key position III.

Diesel engine

1. First turn the ignition dial to key position II and wait until the diesel indicator symbol in the combined instrument panel goes out, see page 47.
2. Following which, turn the ignition dial to position III.

Starting with the remote control key

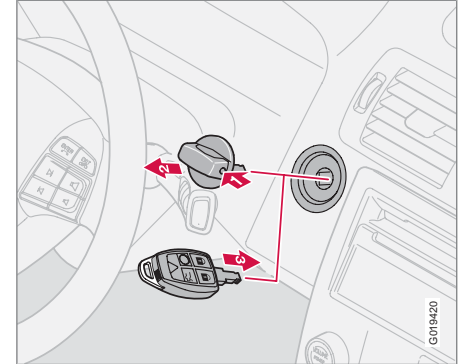

If the remote control key's battery is discharged then the Keyless Drive function does not work. In which case, start the car by using the remote control key as ignition dial.

1. Press in the catch in the ignition dial.
2. Pull the ignition dial out from the ignition switch.
3. Insert the remote control key into the ignition switch and start in the same way as with the ignition dial.

* Option/accessory, for more information, see Introduction.



Manual gearbox

Gear positions - five-speed

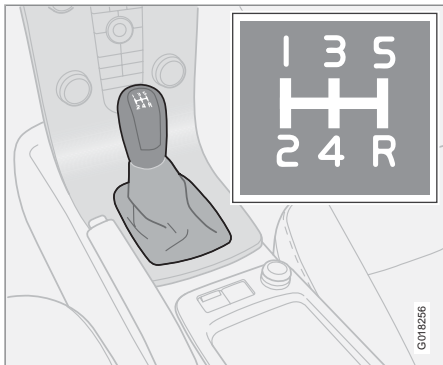

For the best possible fuel economy, use the highest gear possible as often as possible.

- Depress the clutch pedal fully during each gear change.
- Take your foot off the clutch pedal between gear changes.
- Follow the shifting pattern indicated.

Gear shift indicator - GSI*



GSI - Gear Shift Indicator - advises the driver of the optimum time to change gear. The indication is given with an arrow for up and down shifting respectively in the lower information display of the combined instrument panel, see page 45.

Reverse gear inhibitor - five-speed

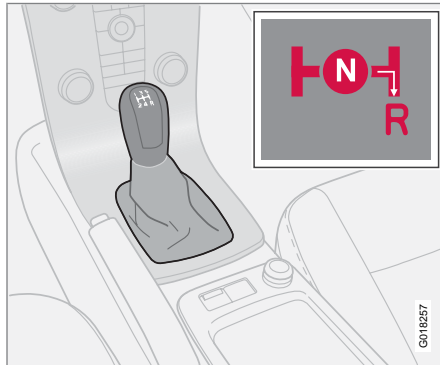

The reverse gear inhibitor hinders the possibility of mistakenly attempting to engage reverse gear during normal forward travel.

Only engage reverse gear when the car is stationary.

- To engage reverse gear, the gear lever must first be put in position **N**. Reverse gear cannot therefore be engaged directly from fifth gear due to the reverse gear inhibitor.

Gear positions - six-speed (petrol)

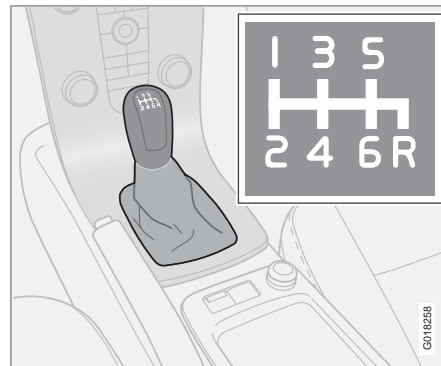

For the best possible fuel economy, use the highest gear possible as often as possible.

- Depress the clutch pedal fully during each gear change.
- Take your foot off the clutch pedal between gear changes.
- Follow the shifting pattern indicated.



Manual gearbox

It may be difficult to find the positions for fifth and sixth gear when the car is stationary as the reverse gear inhibitor (which blocks sideways movement towards reverse) is then not activated.

Reverse gear inhibitor - six-speed (petrol)

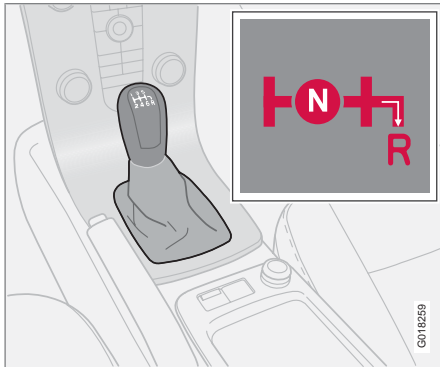

The reverse gear inhibitor hinders the possibility of mistakenly attempting to engage reverse gear during normal forward travel.

Only engage reverse gear when the car is stationary.

i NOTE

Reverse gear is electronically blocked if the car is travelling faster than approx. 20 km/h.

Gear positions - six-speed (diesel)

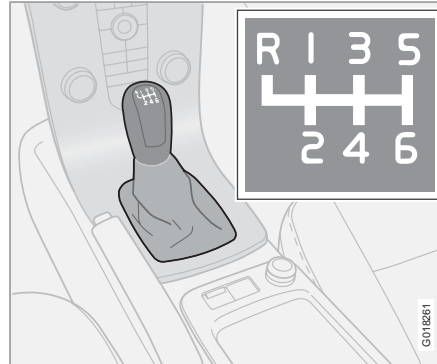

For the best possible fuel economy, use the highest gear possible as often as possible.

- Depress the clutch pedal fully during each gear change.
- Take your foot off the clutch pedal between gear changes.
- Follow the shifting pattern indicated.

Reverse gear inhibitor - six-speed (diesel)

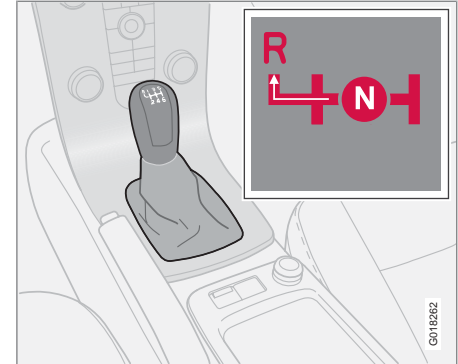

The reverse gear inhibitor hinders the possibility of mistakenly attempting to engage reverse gear during normal forward travel.

Only engage reverse gear when the car is stationary.

- Engage reverse gear by pressing down the gear lever and moving it to the left.



Automatic gearbox

Geartronic automatic gear positions

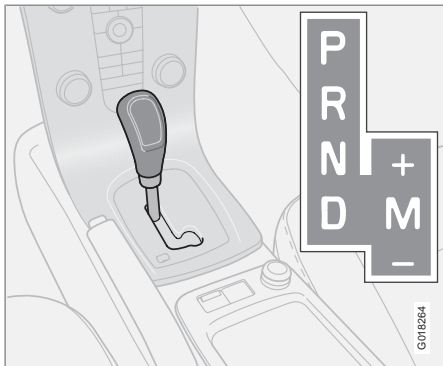

- D** – left-hand position: Automatic gear changing.
- M** – right-hand position: Manual gear changing.

P – Parking position

Select position **P** when you wish to start the engine or park the car.

! IMPORTANT

The car must be stationary when position **P** is selected.

i NOTE

The brake pedal must be depressed to move the gear lever from the **P** position.

The gearbox is mechanically blocked when the **P** position is engaged. Always apply the parking brake when parking the car.

R – Reverse

The car must be stationary when position **R** is selected.

N – Neutral

No gear is engaged and the engine can be started. Apply the parking brake when the car is stationary with the gear selector in position **N**.

i NOTE

The brake pedal must be depressed to move the gear selector from the **N** position if the car has been stationary for more than 3 seconds.

D – Drive

D is the normal driving position. The car automatically shifts up and down depending on the level of acceleration and speed. The car must be stationary when the gear selector is moved to position **D** from position **R**.

Geartronic manual gear positions

The driver can also change gear manually using the Geartronic automatic gearbox. The car engine-brakes when the accelerator pedal is released.

Manual gearshift mode is obtained by moving the lever from position **D** to the right-hand end position at **M**. The information display shifts the indication from **D** to one of the figures **1–6**, depending which gear is engaged just then, see page 45.

- Move the lever forwards towards **+** (plus) to change up a gear and release the lever, which returns to its rest position at **M**.
- Pull the lever back towards **–** (minus) to change down a gear and release the lever.

The manual gearshift mode **M** can be selected at any time while driving.

To return to automatic driving mode: move the lever to the left-hand end position at **D**.

Geartronic automatically shifts down if the driver allows the speed to decrease lower than a level suitable for the selected gear, in order to avoid jerking and stalling.

Kick-down

When the accelerator pedal is pressed all the way to the floor (beyond the position normally regarded as full acceleration) a lower gear is



Automatic gearbox

immediately engaged. This is known as kick-down.

If the accelerator is released from the kick-down position, the gearbox automatically changes up.

Kick-down is used when maximum acceleration is needed, such as for overtaking.

Safety function

To prevent overrevving the engine, the gearbox control program has a protective downshift inhibitor which prevents the kick-down function.

Geartronic does not permit downshifting/kick-down which would result in an engine speed high enough to damage the engine. Nothing happens if the driver still tries to shift down in this way at high engine speed – the original gear remains engaged.

When kick-down is activated the car can change one or more gears at a time depending on engine speed. The car changes up when the engine reaches its maximum speed in order to prevent damage to the engine.

Mechanical gear selector inhibitor

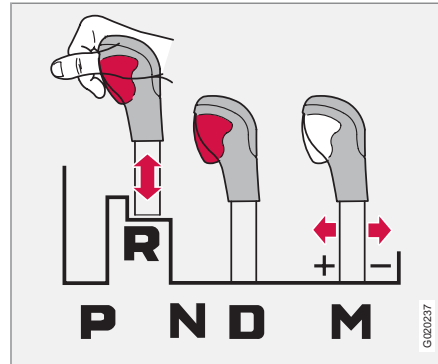

The gear selector can be moved forward and back freely between **N** and **D**. Other positions are locked with a latch that is released with the inhibitor button on the gear selector.

With the inhibitor button depressed the lever can be moved forwards or backwards between **P**, **R**, **N** and **D**.

Automatic gear selector inhibitor

Cars with an automatic gearbox have special safety systems:

Keylock

To remove the remote control key, the gear selector must be in the **P** position. The key is locked in all other positions.

Parking position (P)

Stationary car with engine running:

- Hold your foot on the brake pedal when moving the gear selector to another position.

Electric gear inhibitor – Shiftlock Parking position (P position)

To be able to move the gear selector from the **P** position to other gear positions, the ignition key must be in position **II** and the brake pedal must be depressed.

Shiftlock – Neutral (N position)

If the gear selector is in the **N** position and the car has been stationary for at least three seconds (irrespective of whether the engine is running) then the gear selector is locked in the **N** position.

To be able to move the gear selector from the **N** position to another gear position, the brake pedal must be depressed and the ignition key must be in position **II**.



Automatic gearbox

Disengaging the gear selector inhibitor

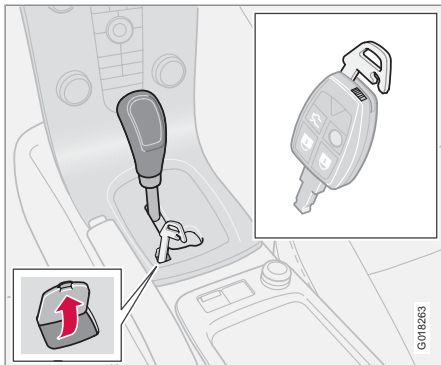

In certain cases, it may be necessary to move the car when it is not driveable, for example if

the battery is flat. Proceed as follows to move the car:

1. There is a small cover behind **P-R-N-D** on the gear selector panel. Open it at the rear edge.
2. Fully insert the key blade from the remote control key.
3. Hold the key blade down and at the same time move the gear lever out of the **P** position.

Cold start

When starting in low temperatures, the gear changes can sometimes feel hard. This is due

to the gearbox oil's viscosity at low temperatures. To reduce engine emissions, the gearbox shifts up later than normal when the engine is started at low temperatures.

NOTE



Depending on the engine temperature when the engine is started, the idle speed after a cold start may be higher than normal for certain engine types.

Text message and action

In some situations the display can show a message at the same time as a symbol is illuminated.



Automatic gearbox

Symbol	Display	Driving characteristics	Action
	TRANSM. OVERHEAT BRAKE TO HOLD	Difficulty in maintaining even speed at constant engine speed.	Gearbox overheated. Keep the car stationary using the foot brake ^A .
	TRANSM. OVERHEAT PARK SAFELY	Significant pulling in the car's traction.	Gearbox overheated. Park the car immediately in a safe manner.
	TRANSM. COOLING LET ENGINE RUN	No drive due to overheated gearbox.	Gearbox overheated. For fastest cooling: Run the engine at idling speed with the gear lever in the N or P position until the message clears.

^A For fastest cooling: run the engine at idling speed with the gear lever in the **N** or **P** position, until the message clears.

The table shows three steps with an increased degree of seriousness should the gearbox become too hot. In parallel with the display text the driver is also advised that the car's electronics are temporarily changing the driving characteristics. Follow the instructions on the information display where appropriate.

 **NOTE**

The table's examples are no indication that the car is defective but instead show that a safety function has been activated intentionally to prevent damage to one of the car's components.

For more possible display messages with their respective proposals for solutions concerning automatic transmission, see page 50.

A display text clears automatically after the action has been carried out or after one press on the indicator stalk **READ** button.



Brake system

Brake servo

If the car is rolling or is being towed with the engine turned off, the brake pedal must be pressed about five times harder than when the engine is running. If the brake pedal is depressed when the engine is started, you will feel the pedal drop. This is normal and due to the brake servo becoming active. This may be more noticeable if the car has Emergency Brake Assistance (EBA).

WARNING

The brake servo only works when the engine is running.

NOTE

If braking with the engine switched off, press the brake pedal sharply once, not repeatedly.

Brake circuits



This symbol illuminates if a brake circuit is not working.

If a fault should occur in one of the circuits, it is still possible to brake the car. The brake pedal will travel further and may feel softer than normal. Harder pressure on the pedal is needed to produce the normal braking effect.

Dampness can affect braking characteristics

Brake components become wet when the car is driven in heavy rain, through pools of water or when the car is washed. This may alter brake pad friction characteristics so that there is a delay before braking effect is noticed.

Press the brake pedal lightly from time to time if driving for long stretches in rain or slushy snow, as well as after setting off in very damp or cold weather. This warms up the brake pads and dries off any water. This precaution is also recommended before parking the car for a long period in such weather conditions.

If the brakes are used heavily

When driving in the Alps or other roads with similar characteristics, the car's brakes are heavily loaded even if the brake pedal is not being depressed especially hard.

Because speed is often low, the brakes are not cooled as effectively as when driving on flat roads at high speed.

So as not to overload the brakes, shift down when driving downhill instead of using the foot brake. Use the same gear driving downhill as you would use driving uphill. This uses engine braking more efficiently so the foot brake is only required for brief periods.

Bear in mind that driving with a trailer puts an additional load on the car's brakes.

Anti-lock braking system (ABS)



The anti-lock braking system (ABS) prevents the wheels from locking up during braking.

This means the ability to steer is maintained and it is easier to swerve to avoid a hazard for example.

After the engine has been started, the ABS will perform a brief self-test at a speed of about 20 km/h. This can be felt and heard as pulses in the brake pedal.

To get the most out of the ABS:

1. Depress the brake pedal with full force. Pulses will be felt.
2. Steer the car in the direction of travel. Do not release the pressure on the pedal.

Practice braking with the ABS system in a traffic-free area and in different weather conditions.

The ABS symbol illuminates for two seconds if there was a fault in the ABS system when the engine was last running.



Emergency Brake Assistance – EBA

(Emergency Brake Assistance) For sudden braking, full-strength braking is provided instantaneously. The EBA function senses when heavy braking is underway by registering how quickly the brake pedal is depressed. Continue braking without easing off on the brake pedal. The function is suspended when the pressure on the brake pedal eases. This function is always active. It cannot be disengaged.



WARNING

If the BRAKE and ABS warning symbols illuminate at the same time, there may be a fault in the brake system. If the level in the brake fluid reservoir is normal at this stage, drive carefully to the nearest workshop and have the brake system checked - an authorised Volvo workshop is recommended.

If the brake fluid is under the **MIN** level in the brake fluid reservoir, do not drive further before topping up the brake fluid.

The reason for the loss of brake fluid must be investigated.



NOTE

When EBA is activated the brake pedal lowers slightly more than usual, depress (hold) the brake pedal as long as necessary. If the brake pedal is released then all braking ceases.



DSTC – Stability and traction control system*

General

The stability and traction control system, STC/DSTC (Dynamic Stability and Traction Control) helps the driver to avoid skidding and improves the car's traction.

A pulsing sound may be noticed during braking or acceleration when the system is in action. The car may accelerate slower than expected when the accelerator pedal is depressed.

The car is equipped with either STC or DSTC depending on market. The table shows the integral functions of the respective systems.

Function/system	STC	DSTC
Active Yaw Control		X
Spin Control	X	X
Traction control system	X	X

Active Yaw Control

The function limits the driving and brake force of the wheels individually in order to stabilise the car.

Spin Control

The function prevents the driving wheels from spinning against the road surface during acceleration.

Traction control system

The function is active at low speed and transfers power from the driving wheel that is spinning to the one that is not.

Reduced operation

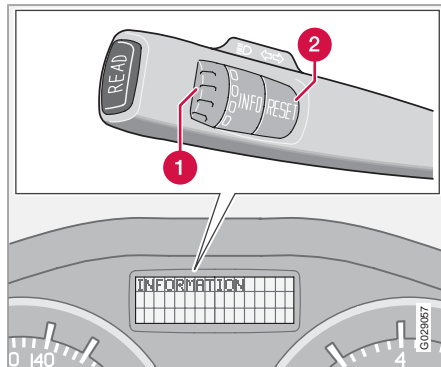

- 1 Thumbwheel¹
- 2 RESET button¹

The stability system is activated automatically each time the car is started.

System operation during skidding and acceleration can be partially deactivated. Operation during skidding is then delayed and so allows more skidding which provides greater freedom for dynamic driving. Traction in deep snow or sand is improved at the same time as acceleration is no longer limited.

Operation

- Turn thumbwheel until the STC/DSTC menu is shown.

DSTC ON means that the system function is unchanged.

DSTC SPIN CONTROL OFF means that system operation is reduced.

- Press and hold the **RESET** button until the STC/DSTC menu is changed.

At the same time the symbol  illuminates as a reminder that the system has been reduced.

The system remains reduced until the engine is next started.

¹ No function in cars without trip computer, fuel-driven parking heater as well as stability and traction control system.

* Option/accessory, for more information, see Introduction.



DSTC – Stability and traction control system*

WARNING

Suppressing system function may alter the driving characteristics of the car.

NOTE

DSTC ON is shown for several seconds on the display and the symbol  illuminates each time the engine is started.

Messages on the information display

TRACTION CONTROL TEMPORARILY

OFF means that the system has been temporarily reduced due to excessive brake temperature. The function is reactivated automatically when the brakes have cooled.

ANTI-SKID SERVICE REQUIRED system disabled due to a fault.

- Stop the car in a safe place and turn off the engine.

If the message remains when the engine is restarted, drive to a workshop - an authorised Volvo workshop is recommended.



Symbols in the combined instrument panel



DSTC system



Information

If the symbols  and  are displayed at the same time: Read the message on the information display.

If the symbol  appears alone then it may appear as follows:

- Flashing light means that the STC/DSTC system is now being activated.
- Constant glow for two seconds means system check when the engine is started.
- Constant glow after starting the engine or while driving means that there is a fault in the STC/DSTC system.
- Constant glow after deactivation reminds that the STC/DSTC system has been reduced.



Park Assist*

General information on parking assistance

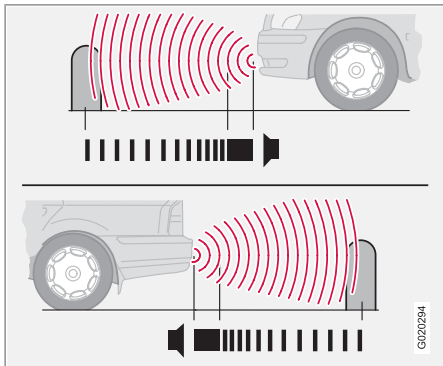

Parking assistance front and rear.

Parking assistance is used as an aid to parking. A signal indicates the distance to a detected obstacle.

! WARNING

Parking assistance does not relinquish the driver's own responsibility during parking. The sensors have blind spots where obstacles cannot be detected. Be aware of children or animals near the car.

Variants

Parking assistance is available in two variants:

- Rear only.
- Both front and rear.

Function

The frequency of the signal increases the shorter the distance to an obstacle, in front of or behind the car. If the volume of another audio source from the audio system is high, then this is automatically lowered.

The tone becomes constant at a distance of about 30 cm. If there are obstacles within this distance both behind and in front of the car, the signal alternates between left and right-hand speakers.

Rear parking assistance only

The system is automatically engaged when the car is started.

Rear parking assistance is activated when reverse gear is engaged and the message **Park Assist active, Exit to deactivate** is shown on the audio system display.

If the system is switched off, the display shows **Park Assist deactivated Enter to activate** as soon as reverse gear is engaged. To change the settings, see page 75.

The distance covered behind the car is about 1.5 metres. The signal comes from the rear loudspeakers.

Limitations

The system must be deactivated when reversing with a trailer, or bike carrier on the towbar or similar. Otherwise the trailer or bike carrier would trigger the sensors.

i NOTE

Rear parking assistance is deactivated automatically when towing a trailer if a Volvo genuine trailer cable is used.

Parking assistance both front and rear

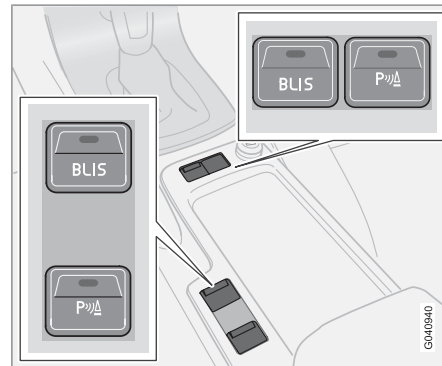

Button for Off/On (button location depends on other selected equipment).



Park Assist*

The system is automatically engaged when the car is started and the switch's On/Off lamp is illuminated. If parking assistance is switched off with the button, the lamp goes out.

Front

Front parking assistance is active at speeds below 15 km/h. The system is deactivated at higher speeds. When the speed is below 10 km/h the system is reactivated.

The distance covered to the front of the car is about 0.8 metres. The signal for obstacles in front comes from the front loudspeakers.

Limitations

Front parking assistance cannot be combined with extra lights because the sensors are affected by the extra lights.

Rear

Rear parking assistance is activated when reverse gear is engaged.

The distance covered to the rear of the car is about 1.5 metres. The signal for obstacles behind comes from the rear loudspeakers.

Limitations

See the previous section Rear parking assistance only.

Fault indicator

If the information symbol illuminates with constant glow and the display shows **PARK ASSIST SERVICE REQUIRED** then parking assistance is disengaged. For attention, contact a workshop - an authorised Volvo workshop is recommended.

**IMPORTANT**

In certain conditions the parking assistance system may produce incorrect warning signals that are caused by external sound sources that emit the same ultrasonic frequencies that the system works with.

Examples of such sources include horns, wet tyres on asphalt, pneumatic brakes and exhaust noises from motorcycles etc.

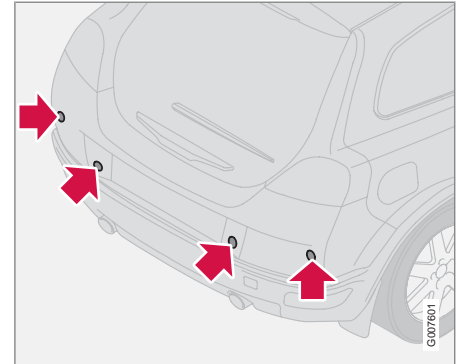
Cleaning the sensors

Parking assistance sensors.

The sensors must be cleaned regularly to ensure that they work properly. Clean them with water and car shampoo.

**NOTE**

Dirt, ice and snow covering the sensors may cause incorrect warning signals.



BLIS* – Blind Spot Information System

General

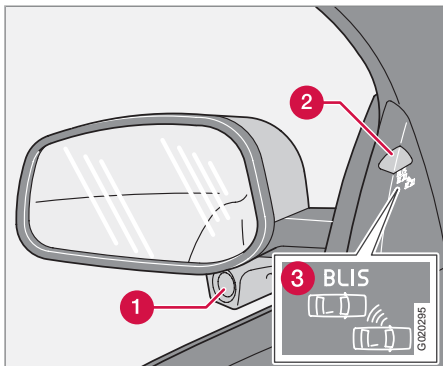

Rearview mirror with BLIS system.

- 1 BLIS camera
- 2 Indicator lamp
- 3 BLIS symbol

WARNING

The system is a supplement to, not a replacement for, a safe driving style and use of the rearview mirrors. It can never replace the driver's attention and responsibility. The responsibility for changing lanes safely always rests with the driver.

BLIS is an information system that under certain conditions can help to draw the driver's attention to vehicles "moving in the same direction in the so-called "blind spot".

The system is designed to work most effectively when driving in dense traffic on multi-lane highways.

BLIS is based on camera technology. The cameras (1) are located under the door mirrors.

When a camera has detected a vehicle inside the blind spot zone the indicator lamp (2) illuminates with a constant glow.

NOTE

The lamp illuminates on the side of the car where the system has detected the vehicle. If the car is overtaken on both sides at the same time then both lamps illuminate.

BLIS advises the driver with a message if a fault arises in the system. If for example the system's cameras are obscured then the BLIS indicator lamp flashes and a message is shown in the information display. In such cases, check and clean the lenses. If necessary, the system can be switched off temporarily by pressing the **BLIS** button, see page 153.

Blind spots

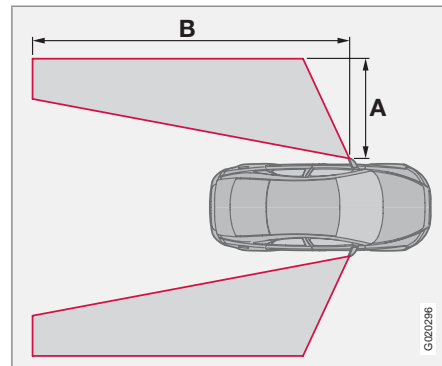

A = approx. 3.0 m, B = approx. 9.5 m.

When BLIS operates

The system operates when the car is driven at a speed above 10 km/h.

Overtaking

The system is designed to react if you overtake another vehicle at a speed of up to 10 km/h faster than the other vehicle.

The system is designed to react if you are overtaken by a vehicle travelling up to 70 km/h faster than your vehicle.



BLIS* – Blind Spot Information System

WARNING

BLIS does not work in sharp bends.

BLIS does not work when the car is reversing.

A wide trailer coupled to the car can conceal other vehicles in adjacent lanes. It can prevent the vehicle in the screened area from being detected by BLIS.

Daylight and darkness

In daylight the system reacts to the shape of the surrounding vehicles. The system is designed to detect motor vehicles such as cars, trucks, buses and motorcycles.

In darkness the system reacts to the headlamps of surrounding vehicles. Vehicles with headlamps that are switched off are not detected by the system. This means for example that the system does not react to a trailer without headlamps which is towed behind a car or truck.

WARNING

The system does not react to bicycles or mopeds.

The BLIS cameras can be disrupted by intensive light or when driving in the dark when there are no light sources (e.g. street lighting or other vehicles). The system may then interpret the lack of light as if the cameras have been blocked.

In both cases a message is shown on the information display.

When driving in such conditions system performance may be temporarily reduced and a text message is shown, see page 154.

If the message disappears automatically then BLIS has returned to normal functionality.

The BLIS cameras have limitations similar to the human eye, i.e. they "see" worse in heavy snowfall or thick fog for example.

Activating/deactivating

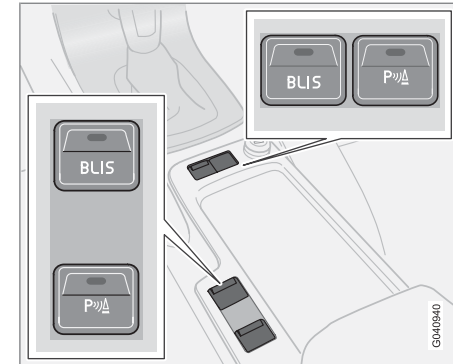

Button for Off/On (button location depends on other selected equipment).

BLIS is activated when the engine is started. The indicator lamps in the door panels flash three times when BLIS is activated.

The system can be deactivated/activated by pressing the **BLIS** button.

When BLIS is deactivated the light in the button goes out and a text message is shown on the dashboard display.

When BLIS is activated the light in the button illuminates, a new text message is shown on the display and the indicator lamps in the door panels flash three times. Press the **READ** but-



BLIS* – Blind Spot Information System

ton to clear the text message. For more information on messages, see page 50.

BLIS system message

Text on the display	Specification
BLIS ON	BLIS system on.
BLIS REDUCED FUNCTION	The BLIS camera is disrupted by fog or strong sunlight, for example, shining directly into the camera. The camera resets itself when the environment has returned to normal.
BLIS CAMERA BLOCKED	One or both cameras blocked. Clean the lenses.

Text on the display	Specification
BLIS SERVICE REQUIRED	Blind spot system disengaged. Contact with an authorised Volvo workshop is recommended.
BLIS OFF	BLIS system off.

! IMPORTANT

Repair of the BLIS system components must only be performed by a workshop - an authorised Volvo workshop is recommended.

Cleaning

In order to work most effectively the BLIS camera lenses must be clean. The lenses can be cleaned with a soft cloth or damp sponge. Clean the lenses carefully so that they are not scratched.

! IMPORTANT

The lenses are electrically heated to melt ice or snow. If necessary, brush snow away from the lenses.

Limitations

In some situations the BLIS indicator lamp may illuminate despite there being no other vehicle within the blind spot.

i NOTE

If the BLIS indicator lamp illuminates on isolated occasions despite there being no other vehicle within the blind spot then this does not mean that a fault has arisen in the system.

In the event of a fault in the BLIS system the display shows the text **BLIS SERVICE REQUIRED**.

Here are several examples of situations where the BLIS indicator lamp may illuminate even if there is no other vehicle within the blind spot.

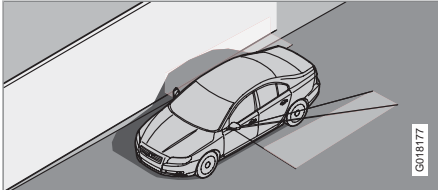

Reflection from shiny wet road surface.

**BLIS* – Blind Spot Information System**

Own shadow on large, light, smooth surface, e.g. noise barrier or concrete road surface.

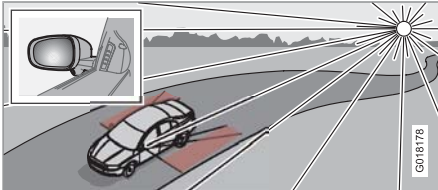

Low sun in the camera.



Towing and recovery

Start assistance

Use a donor battery if the battery is discharged and the engine does not start. Do not tow the car to bump start it, see page 158.

IMPORTANT

Bump starting the car can damage the catalytic converter.

Towing

Find out the highest legal speed for towing before towing the car.

1. Turn the remote control key to position **II** and unlock the steering lock so that the car can be steered, see page 136.
2. The ignition key must remain in position **II** while the car is being towed.
3. Ensure the towrope is always taut by gently depressing the brake pedal to avoid violent jerks.

WARNING

The steering lock remains in the position it was in when the power was cut off. The steering lock must be unlocked before towing.

The remote control key must be in position **II**. Never remove the key from the ignition switch while driving or when the car is being towed.

NOTE

If the car is de-energised then the steering lock must be unlocked using a donor battery before towing can be started.

WARNING

The brake servo and power steering do not work when the engine is switched off. The brake pedal must be pressed about five times harder than normal, and the steering will be considerably heavier than normal.

Manual gearbox

- Move gear lever into neutral and release the parking brake.

Automatic gearbox

- Move the gear selector to position **N** and release the parking brake.

IMPORTANT

Note that the car must always be towed with the wheels rolling forward.

- Cars with automatic gearbox must not be towed at speeds above 80 km/h or further than 80 km.

Model 2.0 Auto

2.0 with automatic gearbox should not be towed. As the transmission fluid cannot be maintained at the correct operating temperature by the engine-driven circulation pump the risk of damage to the gearbox is great.

However, the car can be towed for a short distance at low speed to move it from a dangerous position - not further than 30 km and not faster than 30 km/h.

IMPORTANT

Towing at temperatures below freezing point is strongly advised against.



Towing and recovery

Towing eye

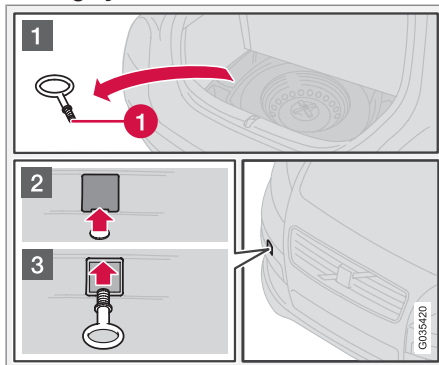

Use the towing eye if the car needs to be towed on the road. The towing eye is attached in the recess on the right-hand side of the front or rear bumper.

Fitting the towing eye

- 1 Take out the towing eye (1) that is located under the floor hatch in the cargo area.
- 2 Release the cover on the bumper by pressing on the marking on the lower edge of the cover.
- 3 Screw in the towing eye firmly, right in up to the flange. Use the wheel wrench to tighten the towing eye.

- After use, unscrew the towing eye and return it to its place.
- Refit the cover on the bumper.

! **IMPORTANT**

The towing eye is only designed for towing on roads, not for pulling the car unstuck or out of a ditch. Call a recovery service for recovery assistance.

i **NOTE**

On certain cars with fitted towbar the towing eye cannot be secured in the rear mounting. In which case, secure the tow rope in the towbar.

For this reason it is advisable to store the towbar's towball in the car, see page 161.

Recovery

Call a recovery service for recovery assistance.

The car must always be towed with the wheels rolling forward.

! **IMPORTANT**

Cars with automatic gearbox must only be towed with drive wheels raised from the road.



Start assistance

Starting with a donor battery

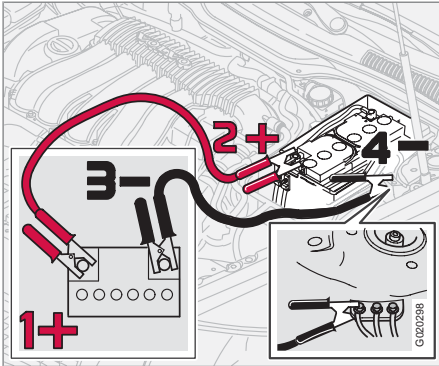

If the battery in the car has become flat, you can "borrow" electric current from either a separate battery or from another car. Always make sure the crocodile clips on the jump leads are attached securely to eliminate sparks during the start attempt.

When jump starting the car, the following steps are recommended to avoid risk of explosion:

1. Turn the remote control key to key position 0.
2. Ensure that the other battery is 12 volt.

3. If the donor battery is in another car, switch off the engine in the other car and ensure that the cars do not touch one another.
4. Connect the red jump lead between the positive terminal on the donor battery (1+) and the positive terminal in your car (2+).
5. Connect one end of the black jump lead to the donor battery's negative terminal (3-).
6. Connect the other end of the black jump lead to the earthing point (4-) by the left-hand strut tower.
7. Start the engine of the "donor car". Let the engine run a few minutes at a speed slightly higher than idle 1500 rpm.
8. Start the engine of the car with the flat battery.
9. Remove the jump leads, first the black and then the red.

Make sure that none of the clamps on the black jump lead comes into contact with the battery's positive terminal or the clamp connected to the red jump lead.

IMPORTANT

Do not touch the crocodile clips during the start procedure. There is a risk of sparks forming.

WARNING

The battery can generate oxyhydrogen gas, which is highly explosive. One spark, which can be generated if you connect the jump leads incorrectly, is sufficient to make the battery explode.

The battery contains sulphuric acid, which can cause serious burns. If the acid comes into contact with eyes, skin or clothing, flush with large quantities of water.

If acid splashes into the eyes, seek medical attention immediately.



Driving with a trailer

General

Payload depends on the car's kerb weight. The total of the weight of the passengers and all accessories, e.g. towbar, reduces the car's payload by a corresponding weight. For more detailed information on weights, see page 263.

If the towing bracket is fitted by an authorised Volvo workshop, then the car is delivered with the necessary equipment for driving with a trailer.

- The car's towing bracket must be of an approved type.
 - If the towbar is retrofitted, check with your Volvo dealer that the car is fully equipped for driving with a trailer.
 - Distribute the load on the trailer so that the weight on the towing bracket follows the specified maximum towball load.
 - Increase the tyre pressure to the recommended pressure for a full load. For tyre pressure decal location, see page 176.
 - Clean the towing bracket regularly and grease the towball¹.
 - Do not tow a heavy trailer when the car is brand new. Please wait until it has been driven at least 1000 km.
- The brakes are loaded much more than usual on long and steep downhill slopes. Downshift to a lower gear and adjust your speed.
 - The engine is loaded more heavily than usual when driving with a trailer.
 - The engine and gearbox can overheat if the car is driven with a heavy load in hot weather. If the temperature gauge for the engine's cooling system goes into the red zone, stop and let the engine idle for a few minutes. The automatic gearbox responds through a built-in protection system. See the message on the information display. If the car overheats, the air conditioning may be switched off temporarily.
 - In the interests of safety, speed should be restricted to 80 km/h, even if the laws of certain countries allow for higher speeds.
 - Move the gear selector to park position **P** when parking an automatic car with a hitched trailer. Always use the parking brake. Block the wheels with chocks when parking a car with hitched trailer on a hill.

Trailer weights

Information on permitted trailer weights, see page 263.



WARNING

Follow the stated recommendations for trailer weights. Otherwise, the car and trailer may be difficult to control in the event of sudden movement and braking.



NOTE

The stated maximum permitted trailer weights are those permitted by Volvo. National vehicle regulations can further limit trailer weights and speeds. Towbars can be certified for higher towing weights than the car can actually tow.

Automatic gearbox, driving with a trailer

Parking on a hill

1. Apply the parking brake (handbrake).
2. Move the gear selector to parking position **P**.

¹ Does not apply to the towball if using a stabiliser hitch.



Driving with a trailer

Starting on a hill

1. Move the gear selector to driving position **D**.
2. Release the parking brake (handbrake).

Steep inclines

- Select an appropriate manual gear position when climbing steep inclines or at low speeds. This prevents the gearbox from changing up and keeps the gearbox oil cooler.
- Do not use a higher manual gear than the engine can "handle". It is not always economical to drive in high gears.
- Avoid driving with a trailer on inclines of more than 12%.

Diesel 1.6D engine with manual gearbox, driving with a trailer

If the car is driven with a major load in a hot climate, the engine cooling fan can be replaced with one of a greater capacity than the standard model. Check with your nearest Volvo dealer regarding the options for your car.



Towing equipment*

Towbar

If the car is equipped with a detachable towbar, the towball mounting instructions must be followed carefully, see page 163.

! WARNING

If the car is fitted with a Volvo detachable towbar:

- Follow the assembly instructions for the towball section carefully.
- The towball section must be locked with the key before setting off.
- Check that the indicator window shows green.

Important checks

- The towball section's towball must be cleaned and greased regularly.

i NOTE

If a towball hitch with vibration damper is used, it is not necessary to grease the towball.

Storing the towball section

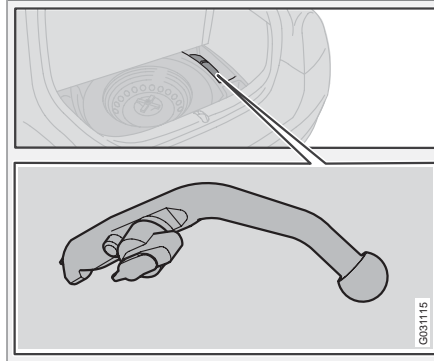

Towball section storage location.

! IMPORTANT

Always remove the towball section after use and store it in the appointed location in the car, firmly fastened with its strap.

Trailer cable

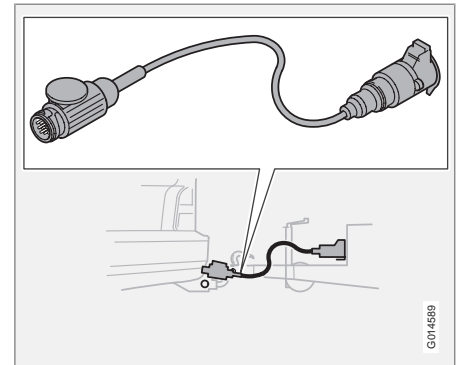

An adapter is required if the car's towing bracket has 13 pin electrics and the trailer has 7 pin electrics. Use an adapter cable approved by Volvo. Make sure the cable does not drag on the ground.



Towing equipment*

Specifications

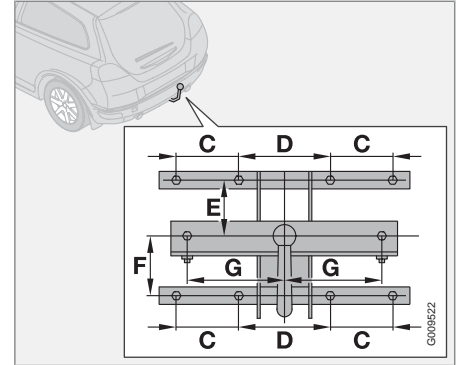
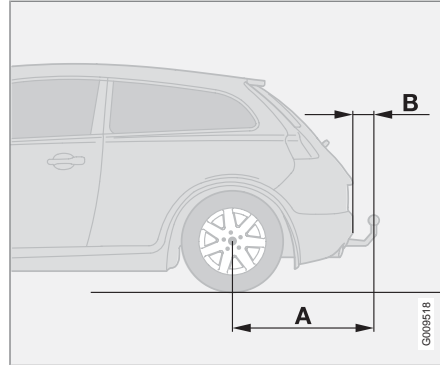
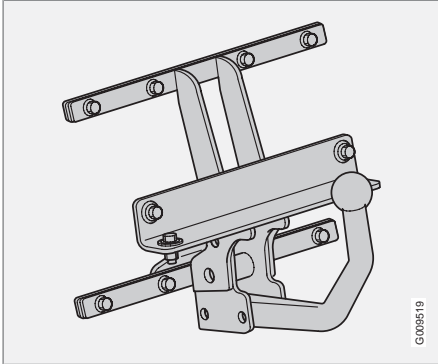

Dimensions for mounting points (mm)

A	B	C	D	E	F	G
854	98	100	140	130	113	150



Detachable towbar*

Fitting the towball

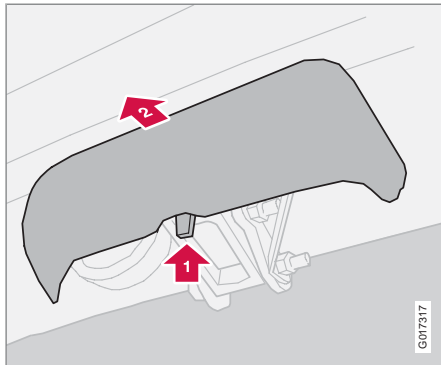

1. Remove the protective cover by first pressing in the catch **1** and then pulling the cover straight back **2**.

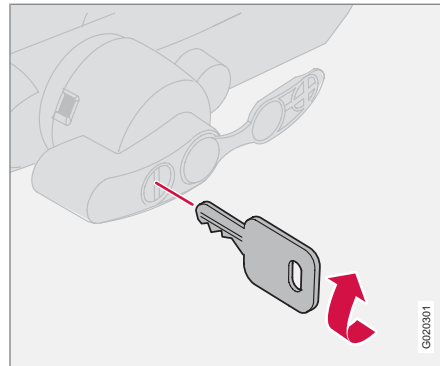

2. Ensure that the mechanism is in the unlocked position by turning the key clockwise.

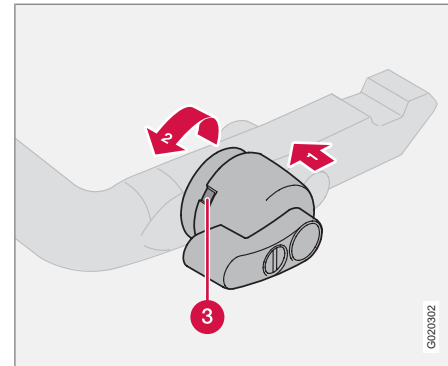

3. Check that the indicator window (3) shows red. If the window does not show red, press in **1** and turn the locking wheel anti-clockwise **2** until you hear a click.



Detachable towbar*

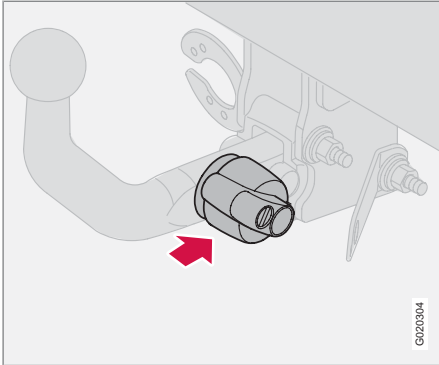

4. Insert the towball section until you hear a click.

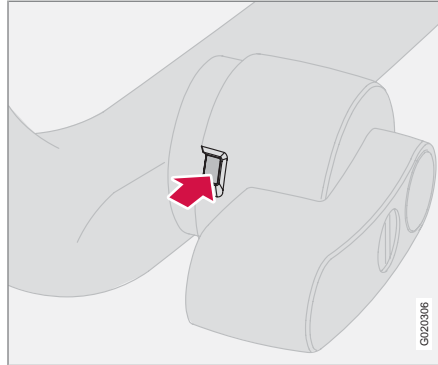

5. Check that the indicator window shows green.

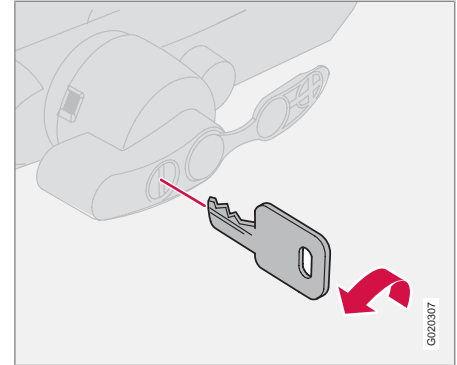

6. Turn the key anticlockwise to locked position. Remove the key from the lock.



Detachable towbar*

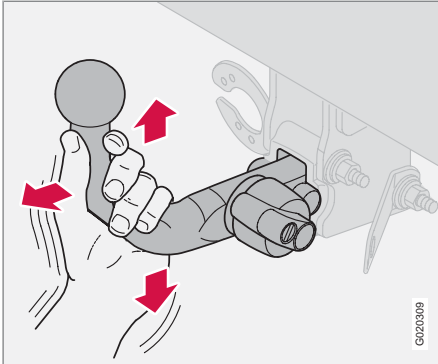

7. Check that the towball section is secure by pulling it up, down and back.

WARNING

If the towball section is not fitted correctly then it must be removed and refitted in accordance with the previous instructions.

IMPORTANT

Only grease in the ball for the towing hitch, the remainder of the towball section should be clean and dry.

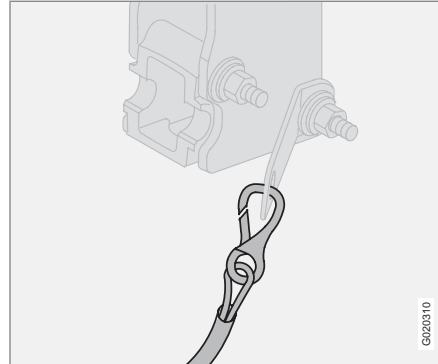

8. Safety cable.

WARNING

Be sure to attach the trailer's safety cable to the correct place.

Removing the towball

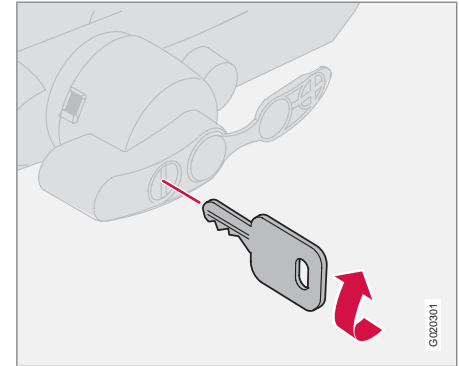

1. Insert the key and turn it clockwise to the unlocked position.



Detachable towbar*

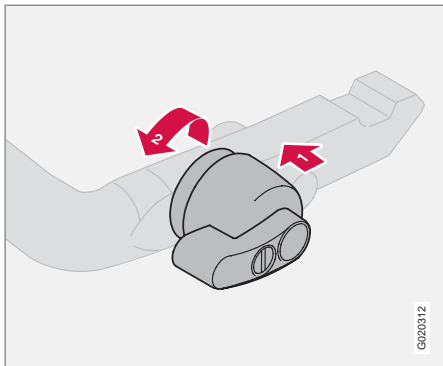

G020312

2. Push in the locking wheel **1** and turn it anticlockwise **2** until you hear a click.

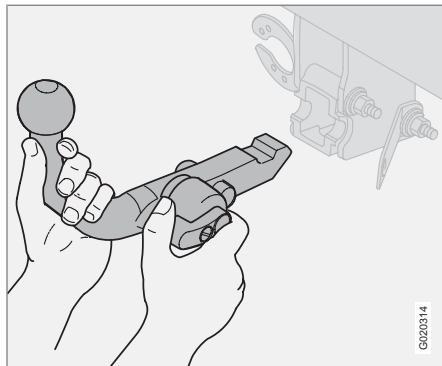

G020314

3. Turn the locking wheel down fully, until it comes to a stop. Hold it in this position while pulling the towball rearward and upward.

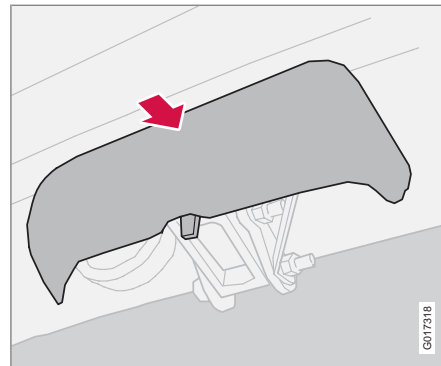

G017318

4. Push on the protective cover.

WARNING

Secure the towbar's loose towball safely if it is stored in the car, see page 161.

**Loading****General**

Payload depends on the car's kerb weight. The total of the weight of the passengers and all accessories reduces the car's payload by a corresponding weight. For more detailed information on weights, see page 263.

WARNING

The car's driving characteristics change depending on how heavily it is loaded and how the load is distributed.

Loading the cargo area

Stop the engine and apply the parking brake when loading or unloading long objects. The gear lever or gear selector can be knocked out of position by long loads, which could set the car in motion.

To increase the size of the cargo area, the head restraints can be removed and the seats folded down, see page 110.

Place the load firmly against the backrest in front.

- The head rests can be removed so that they are not damaged.
- Put wide loads in the centre.

- Heavy objects should be placed as low as possible. Avoid placing heavy loads on a lowered backrest.
- Cover sharp edges with something soft to avoid damaging the upholstery or the glass surface of the tailgate.
- Secure all loads to the load retaining eye-lets with straps or web lashings.

WARNING

A loose object weighing 20 kg can, in a frontal collision at a speed of 50 km/h, carry the impact of an item weighing 1000 kg.

WARNING

Never load cargo above the backrest.

The protection provided by the inflatable curtain in the headlining may be compromised or eliminated by high loads.

Always secure the load. During heavy braking the load may otherwise shift, causing injury to the car's occupants.

Load carriers*

To avoid damaging the car and for maximum possible safety while driving, it is recommended to use load carriers specially designed for your car by Volvo.

Carefully follow the mounting instructions supplied with the carriers.

- Check periodically that the load carriers and load are properly secured. Lash the load securely with retaining straps.
- Distribute the load evenly over the load carriers. Put the heaviest objects at the bottom.
- The size of the area exposed to the wind, and therefore fuel consumption, increase with the load's size.
- Drive gently. Avoid quick acceleration, heavy braking and hard cornering.

WARNING

The car's centre of gravity and driving characteristics are altered by roof loads.



Adjusting headlamp pattern

Correct light pattern for left or right-hand traffic

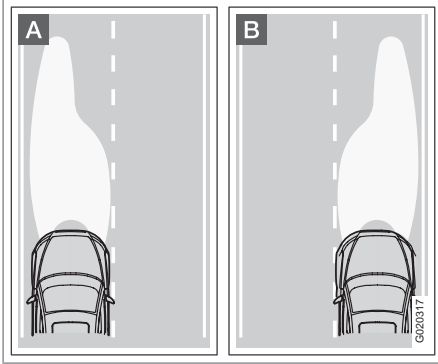

- A** Headlamp pattern for left-hand traffic.
- B** Headlamp pattern for right-hand traffic.

The headlamp pattern can be adjusted using a control in each headlamp housing to avoid dazzling oncoming motorists.

The correct pattern will also better illuminate the verge.

Halogen headlamps

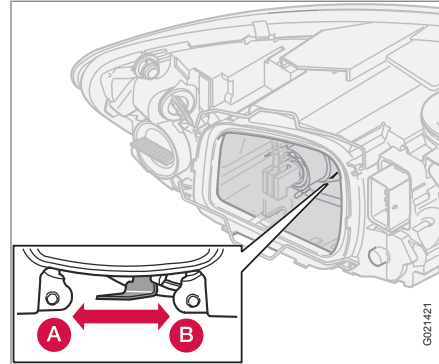

- A** Left-hand traffic.
- B** Right-hand traffic.

Headlamps with Xenon lights

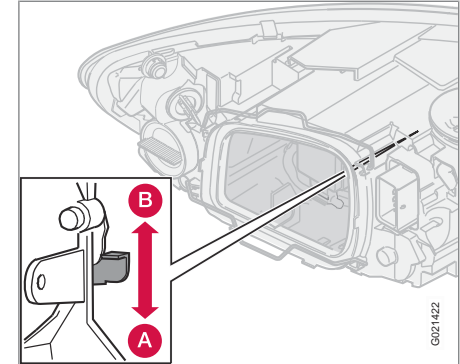

- A** Left-hand traffic.
- B** Right-hand traffic.

WARNING

On cars with Dual Xenon headlamps, Dual Xenon lamp replacement must be carried out at a workshop - an authorised Volvo workshop is recommended. The headlamps must be handled with extreme caution due to the Dual Xenon lamp's high-voltage unit.



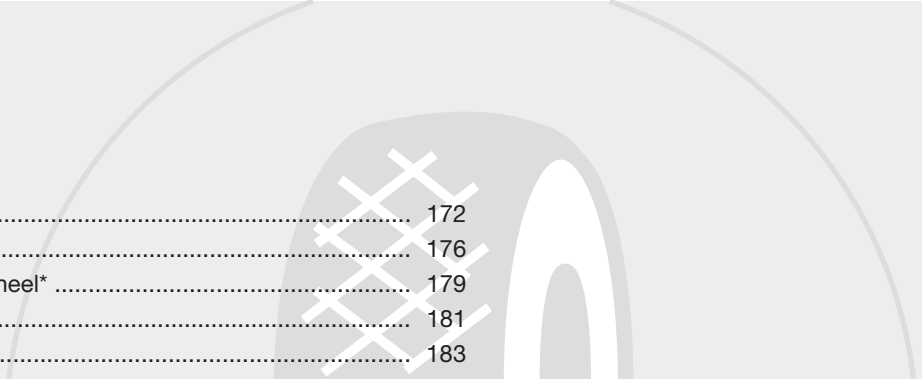

General.....	172
Tyre pressure.....	176
Warning triangle* and spare wheel*	179
Changing wheels.....	181
Emergency puncture repair*	183

WHEELS AND TYRES



07



07 Wheels and tyres

General

Driving characteristics and tyres

The tyres greatly affect the car's driving characteristics. The type of tyre, dimensions, tyre pressure and speed rating are important for how the car performs.

When changing tyres, ensure that tyres of the same type and dimensions, and preferably also the same make, are fitted to all four wheels. Follow the recommended tyre pressures specified on the tyre pressure label, see page 176.

Designation of dimensions

The dimensions are stated on all car tyres. Example: 205/55R16 91 W.

205	Section width (mm)
55	Ratio between section height and width (%)
R	Radial ply
16	Rim diameter in inches (")
91	Tyre load index (in this case 615 kg)
W	Speed rating for maximum permitted speed (in this case 270 km/h).

Speed ratings

The car is approved as a whole, which means that dimensions and speed ratings must not differ from those specified on the vehicle registration document. The only exception to these conditions is winter tyres (both those with metal studs and those without). If such a tyre is chosen, the car must not be driven faster than the speed rating of the tyre (for example, class Q can be driven at a maximum of 160 km/h).

Remember that traffic regulations determine how fast a car can be driven, not the speed class of the tyres.

Note! Maximum permitted speeds indicated.

Q	160 km/h (used only on winter tyres)
T	190 km/h
H	210 km/h
V	240 km/h
W	270 km/h
Y	300 km/h

New tyres

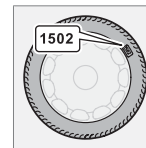

Tyres are perishable. After a few years they begin to harden at the same time as the friction capacity/characteristics gradually deteriorate. For this reason, aim to get as fresh tyres as possible when

you replace them. This is especially important with regard to winter tyres. The last four digits in the sequence mean the week and year of manufacture. This is the tyre's DOT marking (Department of Transportation), and this is stated with four digits, for example 1502. The tyre in the illustration was manufactured in week 15 of 2002.

Tyre age

All tyres older than six years should be checked by an expert even if they seem undamaged. The reason for this is that tyres age and decompose, even if they are hardly ever or never used. The function can therefore be affected due to the tyre's constituent materials being broken down. In such a case the tyre should then not be used. This also applies to spare tyres, winter tyres and tyres saved for future use. Examples of external signs which indicate that the tyre is unsuitable for use are cracks or discoloration.

The age of the tyre can be determined by the DOT marking, see previous illustration.



General

More even wear and maintenance

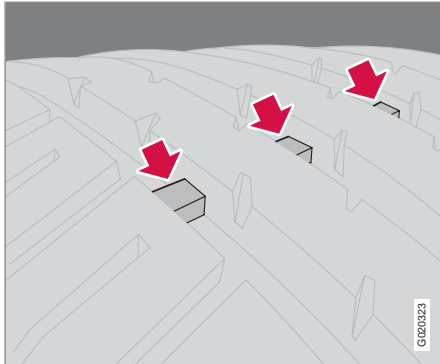

Tread wear indicators.

The correct tyre pressure results in more even wear, see page 176. Driving style, tyre pressure, climate and road condition affect how quickly your tyres age and wear. To avoid differences in tread depth and to prevent wear patterns arising, the front and rear wheels can be switched with each other. A suitable distance for the first change is approx. 5000 km and then at 10000 km intervals. Volvo recommends that you contact an authorised Volvo workshop for checking if you are uncertain about tread depth.

Wheels should be stored lying down or hanging up, and not standing up.

Tyres with tread wear indicators

Tread wear indicators are narrow treadless bands across the width of the tread. On the side of the tyre are the letters TWI (Tread Wear Indicator). When the tyre's tread depth is down to 1.6 mm, the tread depth will be level in height with the tread wear indicators. Change to new tyres as soon as possible. Remember that tyres with little tread depth provide very poor grip in rain and snow.

Winter tyres

Volvo recommends winter tyres with specific winter tyre dimensions. Tyre dimensions are dependent on engine variant. When driving on winter tyres, they must be fitted to all four wheels.

i NOTE

Volvo recommends that you consult a Volvo dealer about which wheel rim and tyre types are most suitable.

Studded tyres

Studded winter tyres should be run in gently for 500-1000 km, so that the studs settle properly into the tyres. This gives the tyre, and especially the studs, a longer service life.

i NOTE

The legal provisions for the use of studded tyres vary from country to country.

Tread depth

Road conditions with ice, slush and low temperatures place considerably higher demands on tyres than summer conditions. It is therefore recommended not to drive on winter tyres that have a tread depth of less than 4 mm.

Snow chains

Snow chains may only be used on the front wheels. This also applies to all-wheel-drive cars.

Never drive faster than 50 km/h with snow chains. Avoid driving on bare ground as this wears out both the snow chains and tyres. Never use quick-fit snow chains as the space between the brake discs and the wheels is too small.

i IMPORTANT

Use Volvo genuine snow chains or equivalent chains designed specifically for the car model, and tyre and wheel rim dimensions. In the event of uncertainty Volvo recommends that you consult an authorised Volvo workshop.

General

Rims and wheel nuts

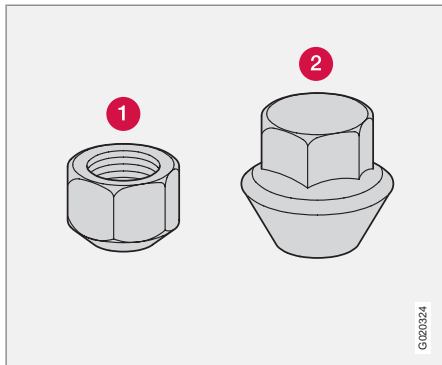

- 1 Standard wheel nuts.
- 2 Bulge acorn wheel nuts.

Only use wheel rims that are tested and approved by Volvo and which are included in the Volvo genuine accessories range.

There are two types of wheel nut, depending on whether the wheel rims are made of steel or aluminium.

1. Tighten the wheel nuts to 110 Nm.
2. Check the torque with a torque wrench.

! IMPORTANT

The wheel nuts should be tightened to 110 Nm. Overtightening can damage the nuts and the bolts.

Steel rims – standard wheel nuts (1)

Steel rims are normally mounted with the standard wheel nuts, but the bulge acorn variety may also be used.

! WARNING

Never use standard nuts for aluminium rims. The wheel could come loose.

Aluminium rims – bulge acorn wheel nuts (2)

Only use the bulge acorn variety of nuts with aluminium rims. These differ markedly from other nut types as they have a rotating conical washer.

i NOTE

These nuts may also be used with steel rims.

Locking wheel nuts

Locking wheel nuts can be used on both aluminium and steel rims. If steel rims with locking wheel nuts are used in combination with wheel covers, the locking wheel nut should be moun-

ted on the bolt nearest the air valve. Otherwise the wheel cover cannot be fitted to the rim.

Spare wheel Temporary Spare*

The spare wheel is only intended to be used for the short time it takes to get the normal wheel replaced or repaired. Replace the spare wheel with a normal wheel as soon as possible. The car's handling may be altered by the use of the spare wheel.

Never drive faster than 80 km/h with a spare wheel on the car.

! IMPORTANT

The car must never be driven fitted with more than one "Temporary Spare" wheel.



Summer and winter wheels

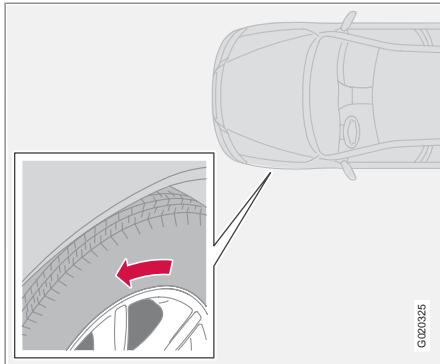

The arrow shows the tyre's direction of rotation.

When summer and winter wheels are changed, see page 181, the wheels should be marked with which side of the car they were mounted on, for example **L** for left and **R** for right. Tyres with a tread pattern which are designed to only turn in one direction have the direction of rotation marked with an arrow.

The tyre must always rotate in the same direction throughout its lifespan. Tyres should only be switched between front and rear positions, never between left and right-hand sides, or vice versa.

If the tyre is mounted incorrectly, the car's braking characteristics and capacity to force

rain, snow and slush out of the way are adversely affected.

Tyres with the greatest tread depth should always be fitted to the rear of the car (to decrease the risk of skidding).

Volvo recommends that you contact an authorised Volvo workshop for checking if you are uncertain about tread depth.



Tyre pressure

Tyre pressure table

Variant	Tyre size	Speed (km/h)	Load, 1 - 3 persons		Max. load		ECO pres- sure ^B
			Front (kPa) ^A	Rear (kPa)	Front (kPa)	Rear (kPa)	
1.6	195/65 R15	0-160	230	210	250	250	250
1.8	205/55 R16	160+	250	210	280	260	-
1.8F	205/50 R17	0-160	240	220	250	250	250
2.0	215/45 R18 ^C	160+	260	220	280	260	-
1.6D							
2.4i	205/55 R16	0-160	230	210	250	250	250
2.0D			160+	250	210	280	260
	205/50 R17	0-160	240	220	250	250	250
	215/45 R18	160+	260	220	280	260	-



07 Wheels and tyres

Tyre pressure

Variant	Tyre size	Speed (km/h)	Load, 1 - 3 persons		Max. load		ECO pressure ^B
			Front (kPa) ^A	Rear (kPa)	Front (kPa)	Rear (kPa)	
T5 D5	205/55 R16	0-160	230	210	250	250	250
		160+	260	210	280	260	-
	205/50 R17	0-160	240	220	250	250	250
	215/45 R18	160+	270	220	290	270	-
Spare wheel ^D	T125/85 R16	0-80	420	420	420	420	-

^A In certain countries there is the "bar" unit beside the SI unit "Pascal": 1 bar = 100 kPa.

^B Fuel-efficient driving see page 176

^C 1.6 and 1.6 DRIVE cannot select this tyre.

^D Temporary Spare.



Warning triangle* and spare wheel*

Warning triangle

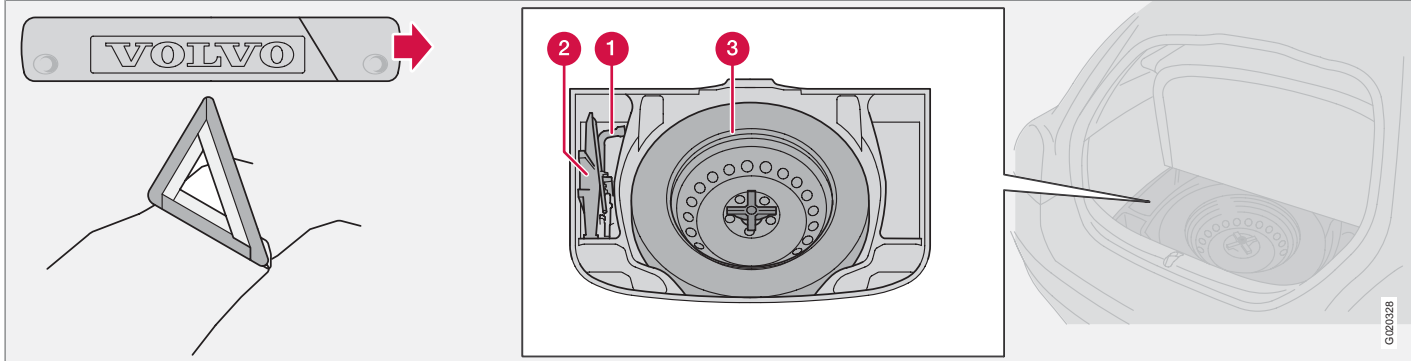

Follow the regulations in force for the use of a warning triangle*. Place the warning triangle in a suitable place with regard to the traffic.

1. Undo the case containing the warning triangle, it is secured with Velcro straps. Take the warning triangle from the case.
2. Lower the warning triangle's support legs. Ensure the warning triangle and its case are firmly secured in the cargo area after use.

Spare wheel* and jack*

The car's original jack*

The original jack* must only be used for changing wheels. The jack's thread should always be well greased. The spare wheel* plus jack* and wheel wrench* are stored under the floor in the cargo area.

 **NOTE**

Volvo recommends only using the jack* that belongs to the car model in question.

Taking out the spare wheel

A bolt runs through to secure the spare wheel.

1. Fold up the cargo area floor.
2. Unscrew the retaining bolt and lift out the wheel.

Putting the spare wheel* and jack* into the cargo area

1. Wheel wrench*.
2. Jack* and handle, secured with a tensioning strap.
3. The spare wheel is bolted down with the rim side down using the through-bolt.



07 Wheels and tyres

Warning triangle* and spare wheel*

Tools - returning into place

Tools and jack* must be returned into place in the correct manner after use.

- For cars equipped with spare wheel, the jack must be cranked so that it fits into the spare wheel.
- For cars equipped with emergency puncture repair kit, the jack must be fully cranked together and returned into the foam block.



IMPORTANT

The tools and jack* must be stored in the intended location in the car's cargo area when not in use.

First aid*

A case with first aid equipment is located in the cargo area.



Changing wheels

Removing wheels

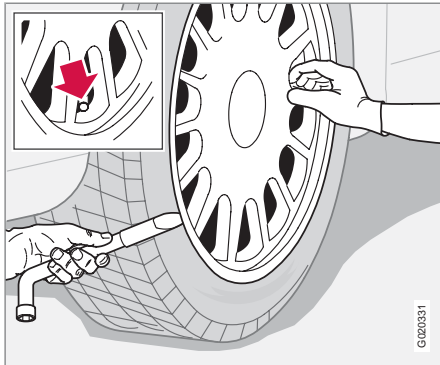

Set up the warning triangle if a wheel must be changed at a busy location. Make sure that the car and jack are on a firm horizontal surface.

! WARNING

Check that the jack is not damaged, that the threads are thoroughly lubricated and that it is free from dirt.

i NOTE

Volvo recommends only using the jack* that belongs to the car model in question.

1. Take out the spare wheel*, jack* and wheel wrench* that are located under the carpet in the cargo area. If another jack is selected, see page 199.

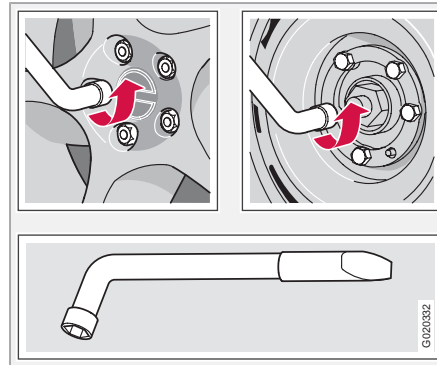

2. Apply the parking brake and engage first gear, or position **P** if the car has an automatic gearbox.
3. Place chocks in front of and behind the wheels which will remain on the ground. Use heavy wooden blocks or large stones.
4. Cars with steel rims have removable wheel covers. Prize off the wheel cover with the end of the wheel wrench, or pull it off by hand.

5. Loosen the wheel nuts ½-1 turn anticlockwise with the wheel wrench.

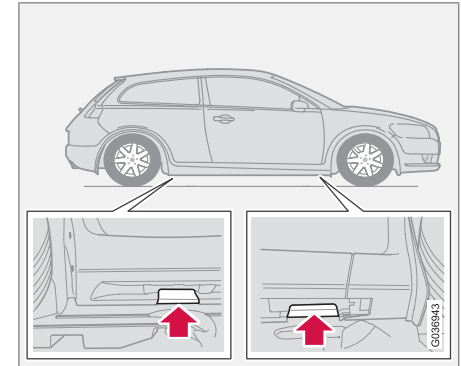

! WARNING

Never position anything between the ground and the jack, nor between the jacking point and the jack.

6. There are two jacking points on each side of the car. There is a recess in the plastic cover at each point. Crank the foot of the jack down so it is pressed squarely on the ground. Check that the jack is seated correctly in the intended jacking point, as illustrated, and that the base is located directly under it.



Changing wheels

7. Lift the car so that the wheel is free.
Remove the wheel nuts and lift off the wheel.

Fitting the wheel

1. Clean the contact surfaces on the wheel and hub.
2. Put on the wheel. Tighten the wheel nuts.
3. Lower the car so that the wheel cannot rotate.
4. Tighten the wheel nuts crosswise. It is important that the wheel nuts are tightened properly. Tighten to 110 Nm. Check the torque with a torque wrench.
5. Put on the wheel cover (steel rim).



WARNING

Never crawl under the car when it is raised on the jack.

Passengers must leave the car when it is raised on the jack.

Ensure that passengers wait with the car - or preferably a crash barrier - between them and the road.



Emergency puncture repair*

Emergency puncture repair, general information

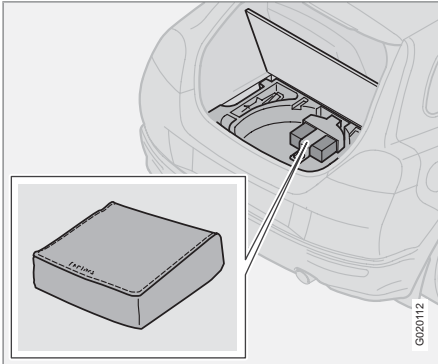

The emergency puncture repair kit is used to seal a puncture as well as to check and adjust the tyre pressure. It consists of a compressor and a bottle with sealing fluid. The kit works as a temporary repair. The sealing fluid bottle must be replaced before its expiration date and after use.

The sealing fluid effectively seals tyres punctured in the tread.

NOTE

The emergency puncture repair kit is only intended for sealing tyres with a puncture in the tread.

The emergency puncture repair kit has limited capacity to seal tyres which have punctures in the wall. Do not seal tyres with the emergency puncture repair kit if they have larger slits, cracks or similar damage.

12 V sockets for the compressor are located by the centre console in the front and by the rear seat. Choose the electrical socket that is nearest the punctured tyre.

WARNING

You should not drive faster than 80 km/h after the emergency tyre repair kit has been used. Volvo recommends that you visit an authorised Volvo workshop for inspection of the sealed tyre (maximum driving distance is 200 km). The staff there can determine whether or not the tyre can be repaired or if it needs to be replaced.

Taking out the emergency puncture repair kit

The emergency puncture repair kit with compressor and tools are stored under the floor in the cargo area.

1. Fold up the cargo area floor.
2. Unscrew the bolt and remove the holder.
3. Lift up the emergency puncture repair kit.

Fitting the emergency puncture repair kit

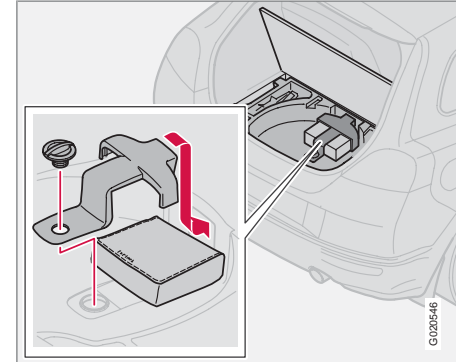

1. Insert the emergency puncture repair kit.
2. Align the holder in the inner and lower grooves of the spare wheel well
3. Screw in the bolt.

NOTE

Incorrect installation of the holder may cause the emergency puncture repair kit to rattle.



Emergency puncture repair*

Overview

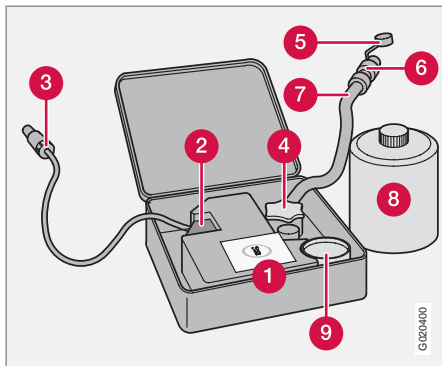

- 1 Decal, maximum permitted speed
- 2 Switch
- 3 Cable
- 4 Bottle holder (orange cap)
- 5 Protective cap
- 6 Pressure reducing valve
- 7 Air hose
- 8 Sealing fluid bottle
- 9 Pressure gauge

Sealing punctured tyres

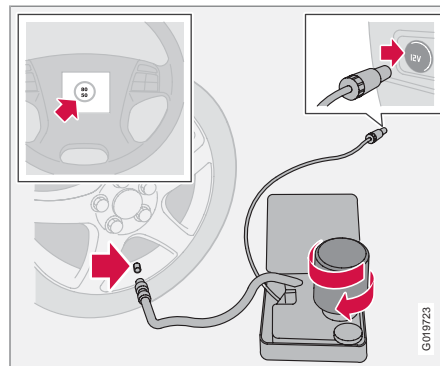

For information on the function of the parts, see preceding illustration.

1. Open the lid of the emergency puncture repair kit.
2. Detach the decal for maximum permitted speed and affix it to the steering wheel.

WARNING

The sealing fluid can irritate the skin. In the case of contact with skin, wash away the fluid with soap and water.

3. Check that the switch is in position 0 and locate the cable and the air hose.

NOTE

Do not break the bottle seal. The seal is broken when the bottle is screwed in.

4. Unscrew the orange cap and unscrew the bottle's stopper.

WARNING

Do not unscrew the bottle, it is equipped with a reverse catch to prevent leakage.

5. Screw the bottle into its holder.
6. Unscrew the wheel's dust cap and screw in the air hose valve connection to the bottom of the thread on the tyre's air valve.

WARNING

Do not leave children in the car without supervision when the engine is running.

7. Plug the cable into the 12 V socket and start the car.



Emergency puncture repair*

WARNING

Never stand next to the tyre when the compressor is operating. If cracks or unevenness arise then the compressor must be switched off immediately. The journey should not continue. Contacting an authorised tyre centre is recommended.

NOTE

When the compressor starts, the pressure can increase up to 6 bar but the pressure drops after approximately 30 seconds.

8. Flick the switch to position I.

IMPORTANT

Risk of overheating. The compressor must not run for more than 10 minutes.

9. Inflate the tyre for 7 minutes.

WARNING

If the pressure is below 1.8 bar then the hole in the tyre is too big. The journey should not continue. Contacting an authorised tyre centre is recommended.

10. Switch off the compressor to check the pressure on the pressure gauge. Minimum

pressure is 1.8 bar and maximum is 3.5 bar.

11. Switch off the compressor and unplug the cable from the 12 V socket.
12. Detach the hose from the tyre valve and fit the valve cap.
13. As soon as possible, drive approximately 3 km at a maximum speed of 80 km/h so that the sealing fluid can seal the tyre.

Rechecking the repair and pressure

1. Reconnect the equipment.
2. Read the tyre pressure on the pressure gauge.
3. If it is below 1.3 bar then the tyre is insufficiently sealed. The journey should not be continued. Contact a tyre centre.
4. If the tyre pressure is higher than 1.3 bar, the tyre must be inflated to the pressure specified on the tyre pressure decal. Release air using the pressure reducing valve if the tyre pressure is too high.

WARNING

Do not unscrew the bottle, it is equipped with a reverse catch to prevent leakage.

5. Switch off the compressor. Detach the air hose and cable. Refit the dust cap.

NOTE

The sealing fluid bottle and hose must be replaced after use. Volvo recommends that this replacement is performed by an authorised Volvo workshop.

WARNING

Check the tyre pressure regularly.

6. Return the emergency puncture repair kit to the cargo area.
7. Volvo recommends that you drive to the nearest authorised Volvo workshop for the replacement/repair of the damaged tyre. Advise the workshop that the tyre contains sealing fluid.

WARNING

You should not drive faster than 80 km/h after the emergency tyre repair kit has been used. Volvo recommends that you visit an authorised Volvo workshop for inspection of the sealed tyre (maximum driving distance is 200 km). The staff there can determine whether or not the tyre can be repaired or if it needs to be replaced.



07 Wheels and tyres

Emergency puncture repair*

Inflating the tyres

The car's original tyres can be inflated by the compressor.

1. The compressor must be switched off. Make sure that the switch is in position **0** and locate the cable and air hose.
2. Unscrew the wheel's dust cap and screw in the air hose valve connection to the bottom of the thread on the tyre's air valve.

WARNING

Inhaling car exhaust fumes could result in danger to life. Never leave the engine running in sealed areas or areas that lack sufficient ventilation.

WARNING

Do not leave children in the car without supervision when the engine is running.

3. Connect the cable to one of the car's 12 V sockets and start the car.
4. Start the compressor by flicking the switch to position **I**.

IMPORTANT

Risk of overheating. The compressor must not run for more than 10 minutes.

5. Inflate the tyre to the pressure specified on the tyre pressure decal. (Release air using the pressure reducing valve if the tyre pressure is too high.)
6. Switch off the compressor. Detach the air hose and cable.
7. Refit the dust cap.

Changing the sealing fluid canister

Replace the bottle before the expiration date has passed. Treat the old bottle as environmentally hazardous waste.

WARNING

The bottle contains 1,2-Ethanol and natural rubber-latex.

Harmful if ingested. Could result in allergic reaction in the event of skin contact.

Avoid contact with the skin and eyes.

Store out of the reach of children.

NOTE

Leave the container at a collection point for storing dangerous waste.





Cleaning.....	190
Touching up paintwork.....	193
Rustproofing.....	194

CAR CARE



08





Cleaning

Washing the car

Wash the car as soon as it becomes dirty. Use car shampoo. Dirt and road salt can lead to corrosion.

- Do not park the car in direct sunlight. Washing a car with hot paintwork can cause permanent paintwork damage. Wash the car in a car wash with waste water separator.
- Hose down the underbody thoroughly.
- Wash using a sponge, car shampoo and plenty of lukewarm water.
- If the dirt is difficult to dislodge, wash the car using a cold degreasing agent.
- Dry the car using a clean, soft chamois or a water scraper.

WARNING

Always have the engine cleaned by a workshop. There is a risk of fire if the engine is hot.

IMPORTANT

Dirty headlamps have impaired functionality. Clean them regularly, when refuelling for example.

NOTE

Outside lighting such as headlamps, fog lamps and rear lamps may temporarily have condensation on the inside of the lens. This is a natural phenomenon, all outside lighting is designed to withstand this. Condensation is normally vented out of the lamp when it has been switched on for a time.

Cleaning the wiper blades

Asphalt, dust and salt residue on wiper blades, as well as insects, ice etc. on the windscreen, impair the service life of wiper blades.

NOTE

Wash the wiper blades and windscreen regularly with lukewarm soap solution or car shampoo.

Do not use any strong solvents.

Removing bird droppings

Wash away bird droppings from the paintwork as soon as possible. Bird droppings contain chemicals that affect and discolour paintwork very quickly. This discoloration can only be removed by a specialist.

Chromed wheels

IMPORTANT

Rim cleaning agents can cause stains on chrome-plated wheels. Wash using a sponge, car shampoo and plenty of lukewarm water.

Automatic car washes

An automatic car wash is a simple and quick way of washing the car, but it can never replace a proper handwashing. The brushes of an automatic car wash cannot reach everywhere.

IMPORTANT

Washing by hand is gentler to the paintwork than an automatic car wash. Paintwork is also more sensitive when it is new. For this reason, handwashing is recommended during the first few months with a new car.

High-pressure washing

When using high-pressure washing, use sweeping movements and make sure that the nozzle does not come closer than 30 cm to the surface of the car (the distance applies to all exterior parts).



Cleaning

! IMPORTANT

Rinse the entire car to remove loose dirt. When using a pressure washer: Make sure that the nozzle of the pressure washer is not closer than 30 cm to the bodywork. Do not spray directly onto the locks.

Testing the brakes

! WARNING

Always test the brakes after washing the car, including the parking brake, to ensure that moisture and corrosion do not attack the brake linings and reduce braking performance.

Lightly depress the brake pedal now and then when driving long distances in rain or slush. This heats and dries the brake pads. Do the same thing after starting in very damp or cold weather.

Exterior plastic, rubber and trim components

A special cleaning agent available from Volvo dealers is recommended for cleaning coloured plastic parts, rubber and trim components (such as glossy trim mouldings). When using such a cleaning agent the instructions must be followed carefully.

! IMPORTANT

Avoid waxing and polishing on plastic and rubber.

When using degreasant on plastic and rubber, only rub with light pressure if it is necessary. Use a soft washing sponge.

Polishing glossy trim mouldings could wear away or damage the glossy surface.

Polishing agent that contains abrasive must not be used.

Polishing and waxing

Polish and wax the car if the paintwork is dull or to give the paintwork extra protection.

The car does not need to be polished until it is at least one year old. However, the car can be waxed before this time. Do not polish or wax the car in direct sunlight.

Wash and dry the car thoroughly before you begin polishing or waxing. Clean off asphalt and tar stains using Volvo tar remover or white spirit. More stubborn stains can be removed using fine rubbing paste designed for car paintwork.

Polish first with a polish and then wax with liquid or solid wax. Follow the instructions on the packaging carefully. Many preparations contain both polish and wax.

! IMPORTANT

Paint treatment such as preserving, sealing, protection, lustre sealing or similar could damage the paintwork. Paintwork damage caused by such treatment is not covered by Volvo warranty.

Water-repellent coating*

Never use products such as car wax, degreaser or similar on glass surfaces as this could ruin their water-repellent properties.

Take care when cleaning so as not to damage the glass surface.

To avoid damaging glass surfaces when removing ice – only use plastic ice scrapers.

There is natural wear of the water-repellent coating.

i NOTE

Treatment with a special finishing agent available from Volvo dealers is recommended in order to maintain the water-repellent properties. This should be used first after three years and then each year.

* Option/accessory, for more information, see Introduction.





Cleaning

Cleaning the interior

Treating stains on fabric upholstery

A special cleaning agent, available from Volvo dealers, is recommended for cleaning the fabric upholstery. Other chemicals can impair the fire retardant qualities of the upholstery.

! IMPORTANT

Sharp objects and Velcro may damage the fabric upholstery.

Treating stains on leather upholstery

Volvo leather upholstery is chromium-free and approved in accordance with the Oeko-Tex 100 standard.

The leather is refined and processed so that it retains its natural characteristics. It is given a protective coating, but regular cleaning is required in order to maintain both characteristics and appearance. Volvo offers a comprehensive product for the cleaning and treatment of leather upholstery which, when used in accordance with the instructions, preserves the leather's protective coating.

After a period of use the natural appearance of the leather will nevertheless emerge, depending more or less on the surface texture of the leather. This is a natural maturing of the leather and shows that it is a natural product.

To achieve best results Volvo recommends cleaning and application of the protective cream once to four times per year (or more if required). Ask a Volvo dealer about Volvo's Leather care product.

! IMPORTANT

Never use strong solvents. Such products may damage fabric, vinyl and leather upholstery.

! IMPORTANT

Note that materials with colour that runs when dry (new jeans, suede garments etc.) may discolour the upholstery material.

Washing instructions for leather upholstery

1. Pour the leather cleaner on the dampened sponge and squeeze out a strong foam.
2. Work the dirt away with gentle circular movements.
3. Dab accurately with the sponge on the stains. Allow the sponge to absorb the stain. Do not rub.
4. Wipe off with soft paper or a cloth and allow the leather to dry completely.

Protective treatment of leather upholstery

1. Pour a small amount of the protective cream on the felted cloth and massage in a thin layer of cream with gentle circular movements on the leather.
2. Allow the leather to dry for 20 minutes before use.

The leather has now been given improved protection against stains and improved UV protection.

Treating stains on interior plastic, metal and wood parts

A special cleaning agent, available from Volvo dealers, is recommended for cleaning interior parts and surfaces. Do not scrape or rub stains. Never use strong stain removers.

Cleaning seatbelts

Use water and a synthetic detergent. A special textile cleaning agent is available from your Volvo dealer. Make sure the seatbelt is dry before allowing it to retract.



Touching up paintwork

Paintwork

Paint is an important part of the car's rust-proofing and should therefore be checked regularly. To avoid the onset of rust, damaged paintwork should be rectified immediately. The most common types of paintwork damage are stone chips, scratches, and marks on the edges of wings and doors.

Colour code

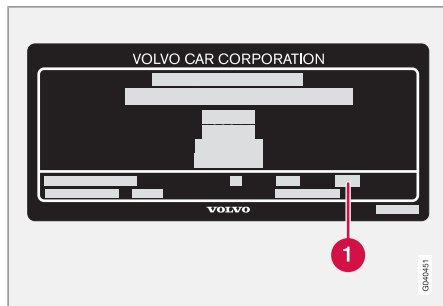

Data plate.

① Code for car colour

It is important that the correct colour is used. For product label location, see page 260.

Stone chips and scratches

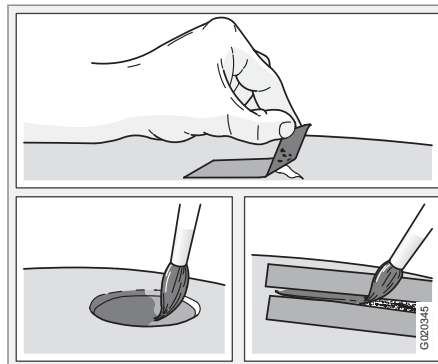

Before touching up paintwork, the car must be clean and dry and at a temperature above 15 °C.

Materials

- Primer in a can
- Paint in a can or touch-up pen
- Brush
- Masking tape.

Minor stone chips and scratches

If the stone chip has not penetrated to the bare metal and there is an undamaged colour coat, you can paint straight after cleaning the damaged area.

If the stone chip has penetrated to the bare metal

1. Apply a piece of masking tape over the damaged surface. Then remove the tape to remove any loose paint.
2. Stir the primer well and apply using a fine brush or a matchstick. Apply paint using a brush once the primer is dry.
3. For scratches, proceed as above, but mask around the damaged area to protect the undamaged paintwork.
4. After a few days, polish the touched-up areas. Use a soft rag and a small amount of lapping paste.



Rustproofing

Inspection and maintenance

Your car has already received a thorough and complete rustproofing at the factory. Parts of the body are made of galvanised sheet metal. The underbody is protected by a wear-resistant anti-corrosion compound. A thin, penetrating rustproofing fluid was sprayed into the members, cavities and closed sections.

Maintain the car's rustproofing.

- Keep the car clean. Hose down the underbody. If using a pressure washer, keep the nozzle at least 30 cm from the painted surfaces.
- Regularly check and touch-up the rustproofing treatment as necessary.

The car's rustproofing does not normally require treatment for approximately 12 years. After this period, it should be treated at three-year intervals. If the car needs further treatment, Volvo recommends that you engage an authorised Volvo workshop for assistance.



Volvo service.....	198
Self-maintenance.....	199
Bonnet and engine compartment.....	200
Oils and fluids.....	202
Wiper blades.....	207
Battery.....	209
Replacing bulbs.....	211
Fuses.....	218

MAINTENANCE AND SERVICE

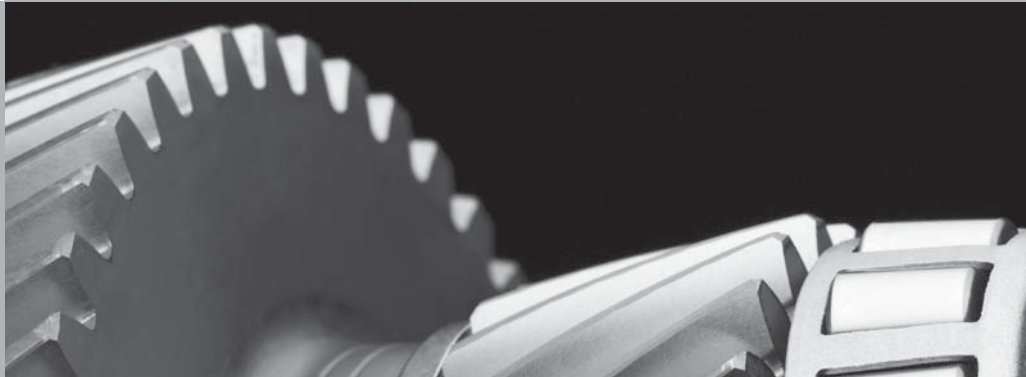

09



Volvo service

Volvo service programme

Before the car left the factory, it was thoroughly test driven. It was checked again in accordance with Volvo Car Corporation regulations before it was handed over to you.

To keep your Volvo as safe and reliable as possible, follow the Volvo service programme specified in the Service and Warranty Booklet. Volvo also recommends that you engage an authorised Volvo workshop to perform the service and maintenance work. Volvo workshops have the personnel, special tools and service literature to guarantee the highest quality of service.



IMPORTANT

For the Volvo warranty to apply, check and follow the instructions in the Service and Warranty Booklet.

Special service measures

Certain service measures which affect the car's electrical system can only be performed using electronic equipment specially developed for your car. For this reason, Volvo recommends that you always contact an authorised Volvo workshop before beginning or performing service work that affects the electrical system.



Self-maintenance

Before starting work on the car

Battery

Check that the battery cables are correctly connected and tightened.

Never disconnect the battery when the engine is running (e.g. if replacing the battery).

Never use a quick charger to charge the battery. The battery cables must be disconnected when charging the battery.

The battery contains acid that is both corrosive and toxic. It is therefore important to handle the battery in an environmentally correct manner. Let your Volvo dealer assist you.

 **WARNING**

High output from the ignition system. The voltage in the ignition system is highly dangerous. The ignition must therefore always be switched off for work in the engine compartment.

Do not touch the spark plugs or ignition coils when the ignition is on or the engine is hot.

Raising the car

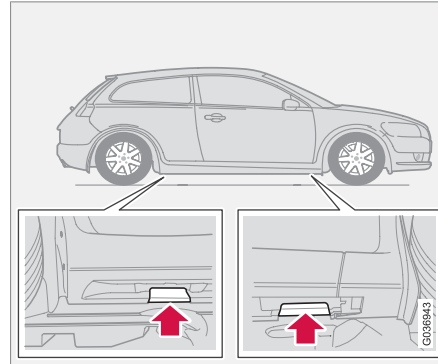
 **NOTE**

Volvo recommends only using the jack that belongs to the car model in question. If a jack other than one recommended by Volvo is selected, then follow the instructions included with the equipment

If the car is raised with a workshop jack; position the jack against the front edge on the subframe.

Do not damage the splashguard under the engine. Ensure that the jack is positioned so that the car cannot slide off the jack. Always use axle stands or similar.

If you raise the car using a two-pillar workshop lift, ensure that the front and rear lift arms are fixed under the lifting points on the door sill. See preceding illustration.

Check regularly

Check the following at regular intervals, for example, when refuelling:

- Coolant – The level must be between the **MIN** and **MAX** marks on the expansion tank.
- Engine oil – The level must be between the **MIN** and **MAX** marks.
- Power steering fluid – The level must be between the **MIN** and **MAX** marks.
- Washer fluid – The reservoir should be well filled. Use washer antifreeze at temperatures around freezing.
- Brake and clutch fluid – The level must be between the **MIN** and **MAX** marks.

 **WARNING**

Bear in mind that the radiator fan may start automatically some time after the engine has been switched off.

Always have the engine cleaned by a workshop. There is a risk of fire if the engine is hot.



Bonnet and engine compartment

Opening the bonnet

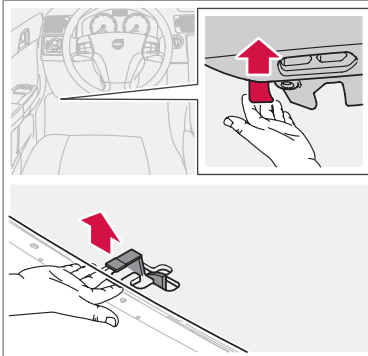

The illustration shows a left-hand drive car.

1. Pull the handle on the far left under the instrument panel. (In right-hand drive cars the handle is on the far right.) You will hear when the catch releases.
2. Insert your hand under the centre of the front edge of the bonnet and press the safety catch to the right.
3. Open the bonnet.

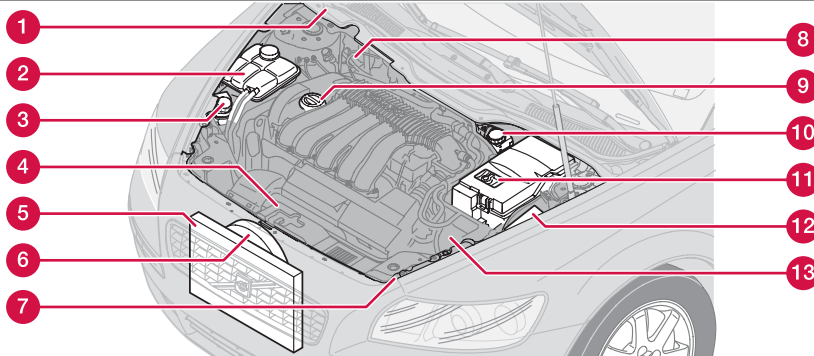

GM10699



WARNING

Check that the bonnet locks properly when closed.

Engine compartment

- | | |
|---|---|
| <ol style="list-style-type: none"> 1 Washer fluid reservoir (4-cyl.) 2 Coolant expansion tank 3 Reservoir for the power steering fluid (concealed behind the headlamp) | <ol style="list-style-type: none"> 4 Engine oil dipstick¹ 5 Radiator 6 Radiator fan 7 Washer fluid reservoir (5-cyl.) 8 Brake and clutch fluid reservoir (right-hand drive) 9 Filler opening for engine oil¹ 10 Brake and clutch fluid reservoir (left-hand drive) |
|---|---|

¹ The location varies depending on engine alternative



Bonnet and engine compartment

- 1 Battery
- 2 Relay and fuse box
- 3 Air filter¹

¹ The location varies depending on engine alternative



Oils and fluids

Engine compartment decal for oil grade.

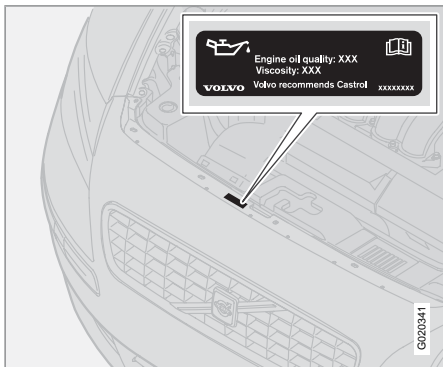

Checking the engine oil and oil filter

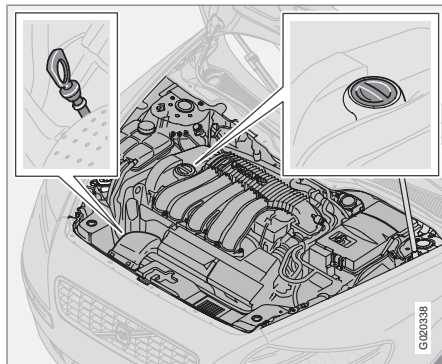

Dipstick, petrol engines.

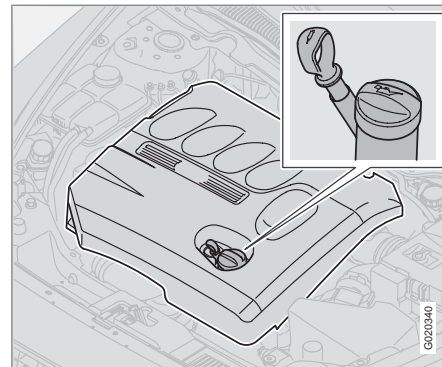

Dipstick, diesel engines. (D5, Euro 5 has an electronic dipstick.)

! IMPORTANT

Always use oil of the prescribed grade, see the engine compartment decal. Check the oil level frequently and change the oil regularly. The engine will be damaged if lower grade oil is used or if the car is driven with the oil level too low.

Using oil of a higher than specified grade is permitted. If the car is driven in adverse conditions, Volvo recommends using an oil of a higher grade than that specified on the decal, see page 268.

Volvo recommends Castrol oil products.

Change the oil and oil filter in accordance with the intervals specified in the Service and Warranty Booklet.

**! IMPORTANT**

In order to fulfil the requirements for the engine's service intervals all engines are filled with a specially adapted synthetic engine oil at the factory. The choice of oil has been made very carefully with regard to service life, starting characteristics, fuel consumption and environmental impact.

An approved engine oil must be used in order that the recommended service intervals can be applied. Only use a prescribed grade of oil (see the engine compartment decal) for both filling and oil change, otherwise you will risk affecting service life, starting characteristics, fuel consumption and environmental impact.

Volvo Car Corporation disclaims all warranty liability if engine oil of the prescribed grade and viscosity is not used.

Volvo uses different systems for warning of low oil level or low oil pressure. Certain variants have an oil pressure sensor, and then the lamp for oil pressure is used. Other variants have an oil level sensor, and then the driver is informed via the warning symbol in the centre of the instrument unit as well as by display texts. Certain models have both variants. Volvo recommends that you contact an authorised Volvo dealer for further information.

Checking the oil level in a new car is especially important before the first scheduled oil change. The Service and Warranty Booklet specifies the odometer readings for oil changes.

Volvo recommends checking the oil level every 2 500 km. The most accurate measurements are made on a cold engine before starting. The measurement will be inaccurate if taken immediately after the engine is switched off. The dipstick will indicate that the level is too low because the oil has not had time to flow down into the oil sump.

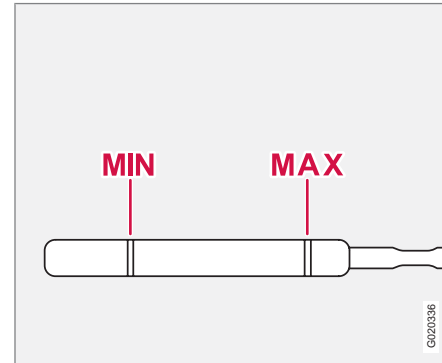
Checking the oil

The oil level must be within the area marked on the dipstick.

Checking the oil in a cold engine

1. Wipe the dipstick clean before checking the level.
2. Check the oil level using the dipstick. The level must be between the **MIN** and **MAX** marks.
3. If the level is close to the **MIN** mark, start by topping up with 0.5 litres. Top up until the oil level is nearer the **MAX** than the **MIN** mark on the dipstick, see page 268 for capacities.

Checking the oil in a warm engine

1. Park the car on a level surface, switch off the engine and then wait 10-15 minutes to allow the oil time to run back to the sump.
2. Wipe the dipstick clean before checking the level.
3. Check the oil level using the dipstick. The level must be between the **MIN** and **MAX** marks.

If the level is close to the **MIN** mark, start by topping up with 0.5 litres. Top up until the oil level is nearer the **MAX** than the **MIN** mark on the dipstick, see page 268 for capacities.



Oils and fluids

WARNING

Do not spill oil onto the hot exhaust manifold due to the risk of fire.

IMPORTANT

Never fill above the **MAX** mark. Oil consumption may increase if too much oil is poured into the engine.

For engines with electronic dipstick¹

The oil level is checked using the electronic oil level gauge with the thumbwheel when the engine is switched off, see page 56.

Checking the oil level:

1. Switch the ignition to key position II, see page 135.
2. Turn the thumbwheel to position "OIL LEVEL ENGINE".
 - > The oil level in the engine is then shown.

NOTE

The oil level is only updated by the system during driving. The system cannot detect changes when oil is filled or drained.

If engine oil is filled or drained then the car must be driven about 30 km before the oil level is measured correctly.

Message	
OK	All normal
PLEASE WAIT	System initialised, shown for about 2 seconds
OIL LEVEL LOW. FILL 1 LITRE OIL	Fill with engine oil, see page 200, chapter "Engine compartment".
SERVICE REQUIRED	Shown when the system has detected something that needs to be rectified in order to enable the correct information regarding oil volume to be shown

Washer fluid, topping up

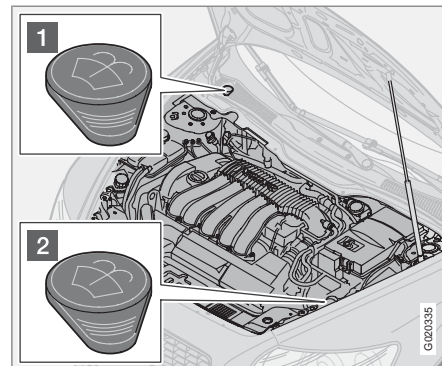

Location of washer fluid reservoir².

The windscreen and headlamp washers share a common reservoir.

For capacities, see the table Fluids on page 272.

- 1 Filler cap on 4-cylinder engines and diesel.
- 2 Filler cap on 5-cylinder engines.

Add washer antifreeze during the winter so that the fluid does not freeze in the pump, reservoir and hoses.

¹ Only applies to diesel (D5) with Euro 5.

² Depending on engine alternative.



Oils and fluids

NOTE

Mix the washer antifreeze and water before filling the reservoir.

TIP! Clean the wiper blades when topping up washer fluid.

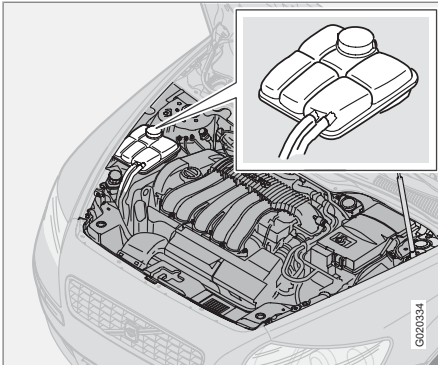
Checking and topping up the coolant

When topping up the coolant, follow the instructions on the packaging. It is important that the mixture of coolant concentrate and water is correct for the prevailing weather conditions. Never top up with water only. The risk of freezing increases with both too little and too much coolant concentrate.

IMPORTANT

- A high content of chlorine, chlorides and other salts may cause corrosion in the cooling system.
- Always use coolant with anti-corrosion agent as recommended by Volvo.
- Ensure that the coolant mixture is 50% water and 50% coolant.
- Mix the coolant with approved quality tap water, see page 272. In the event of any doubt about water quality, used ready-mixed coolant in accordance with Volvo recommendations.
- When changing coolant/replacing cooling system components, flush the cooling system clean with approved quality tap water or flush with ready-mixed coolant, see page 272.
- The engine must only be run with a well-filled cooling system. High temperatures can occur, causing a risk of damage (cracks) to the cylinder head.

For capacities and for standards regarding water quality, see page 272.

Check the coolant regularly

The level must lie between the **MIN** and **MAX** marks on the expansion tank. If the system is

not filled sufficiently, high local temperatures could occur, causing a risk of damage (cracks) to the cylinder head. Top up the coolant when the level falls to the **MIN** mark.

WARNING

Coolant can be very hot. If the coolant requires topping up when the engine is at operating temperature, unscrew the expansion tank cap slowly to gently release the overpressure.

NOTE

The engine must only be run with a well-filled cooling system. High temperatures can occur, causing a risk of damage (cracks) to the cylinder head.



Oils and fluids

Checking and topping up the brake and clutch fluid

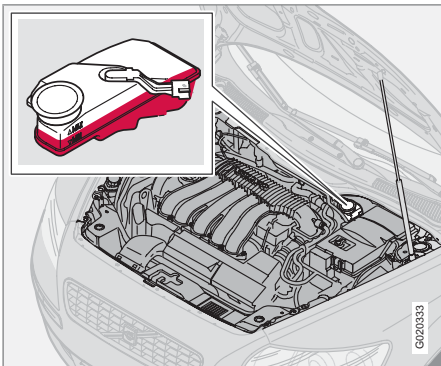

Brake and clutch fluid have a common reservoir³. The fluid level must be between the **MIN** and **MAX** marks. Check the level regularly. Change the brake fluid every other year or at every other regular service.

For capacities and recommended fluid grade, see the table Fluids on page 272.

The fluid should be changed annually on cars driven in conditions requiring hard, frequent braking, such as driving in mountains or tropical climates with high humidity.

WARNING

If the brake fluid is under the **MIN** level in the brake fluid reservoir, do not drive further before topping up the brake fluid.

The reason for the loss of brake fluid must be investigated.

Checking and topping up the power steering fluid

NOTE

Check the level frequently.

The fluid does not require changing. For capacities and recommended fluid grade, see page 268.

If a fault should arise in the power steering system or if the car is without power and must be towed, it can still be steered. However, the steering will be much heavier than normal and it will require more effort to turn the steering wheel.

³ Location dependent on whether car is left or right-hand drive.



Wiper blades

Wiper blades

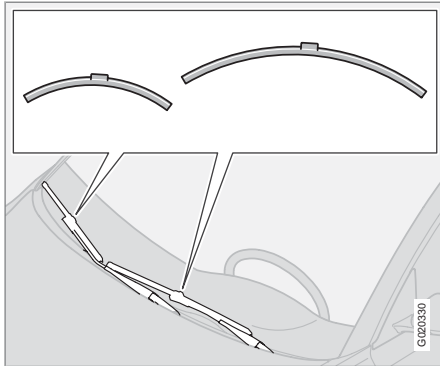
**i** NOTE

The wiper blades are different lengths. The blade on the driver's side is longer than on the other side.

Cleaning

For cleaning wiper blades and windscreen, see page 190.

! IMPORTANT

Check the wiper blades regularly. Neglected maintenance shortens the service life of the wiper blades.

Replacing the wiper blades, windscreen

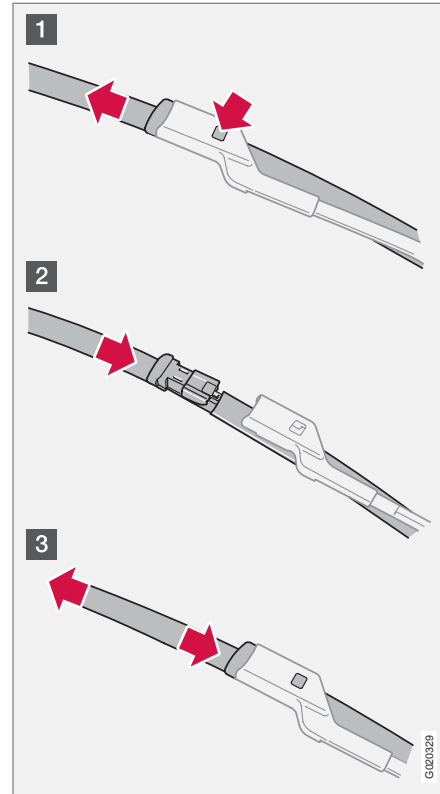

1. Turn up the wiper arm.
2. Press the button located on the wiper blade mounting and pull straight out (1), parallel with the wiper arm.
3. Slide in (2) the new wiper blade until a "click" is heard.
 - > Check (3) that the blade is firmly installed and fold down the wiper arm.

Changing the rear window wiper blade

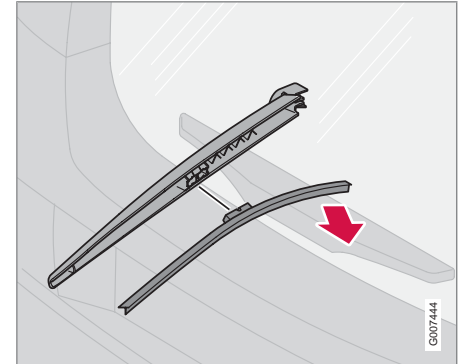

1. Fold out the wiper arm.
2. Detach the wiper blade by pulling it towards the rear window.
3. Press the new wiper blade into position.



Wiper blades

- > Check that it is firmly installed and fold back the wiper arm.

**Battery****Battery care**

The service life and function of the battery is influenced by factors such as the number of starts, discharging, driving style, driving conditions and climatic conditions.

NOTE

An expended battery must be recycled in an environmentally correct manner as it contains lead.

WARNING

Batteries can generate oxyhydrogen gas, which is highly explosive. One spark, which can be generated if you connect the jump leads incorrectly, is sufficient to make the battery explode. The battery contains sulphuric acid, which can cause serious burns. If the acid comes into contact with eyes, skin or clothing, flush with large quantities of water. If acid splashes into the eyes, seek medical attention immediately.

NOTE

The life of the battery is shortened if it becomes discharged repeatedly.

The life of the battery is affected by several factors, including driving conditions and climate. Battery starting capacity decreases gradually with time and therefore needs to be recharged if the car is not used for a longer time or when it is only driven short distances. Extreme cold further limits starting capacity.

To maintain the battery in good condition, at least 15 minutes of driving/week is recommended or that the battery is connected to a battery charger with automatic trickle charging.

A battery that is kept fully charged has a maximum service life.

Symbols on the battery

Use protective goggles.



Further information in the owner's manual.



Store the battery out of the reach of children.



The battery contains corrosive acid.



Battery



Avoid sparks and naked flames.



Risk of explosion.

8. Remove the battery.

Fitting the battery

1. Fit the battery into position.
2. Fit the clamp securing the battery.
3. Reinstall the front wall of the battery box.
4. Connect the positive lead.
5. Connect the negative lead.
6. Refit the cover over the battery.

Changing the battery

Removing the battery

1. Switch off the ignition and remove the remote control key.
2. Wait at least 5 minutes before touching any electrical terminals. The car's electrical system has to store information in the control modules.
3. Remove the cover.
4. Disconnect the negative battery lead.
5. Disconnect the positive battery lead.
6. Undo the front wall of the battery box using a screwdriver.
7. Release the clamp securing the battery.



Replacing bulbs

General

All bulb specifications are given on page 279.

The following list contains bulbs and point-source lamps that are specialised or unsuitable for changing except at a workshop:

- General interior lighting in the roof
- Reading lamps and glovebox lighting
- Direction indicators, door mirror and approach lighting
- High-level brake light
- Dual Xenon headlamps

WARNING

On cars with Dual Xenon headlamps, Dual Xenon lamp replacement must be carried out at a workshop - an authorised Volvo workshop is recommended. The headlamps must be handled with extreme caution due to the Dual Xenon lamp's high-voltage unit.

IMPORTANT

Never touch the glass part of the bulbs with your fingers. Grease and oil from your fingers are vaporised by the heat, coating the reflector and then causing damage.

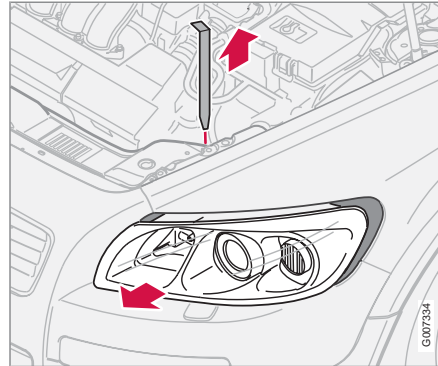
Changing front bulbs

All front bulbs (except for fog lamps) are changed by first removing the lamp housing from the engine compartment.

Removing the lamp housing

1. Remove the remote control key and turn the light switch to position 0.
2. Withdraw the lamp housing's locking pin.

IMPORTANT

Do not pull the electrical cable, only the connector.

3. Pull the lamp housing to the side and then forward.
4. Unplug the connector by pressing down the clip with a thumb while moving out the connector with the other hand.

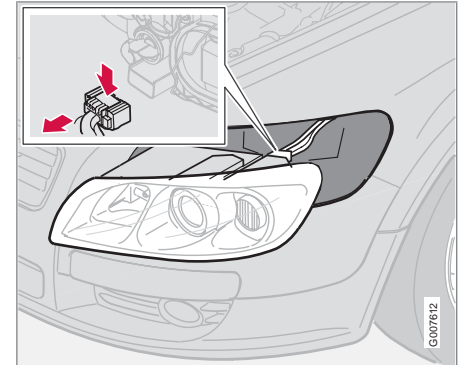

5. Lift out the lamp housing and place it on a soft surface to avoid scratching the lens.

Fitting the lamp housing

1. Plug in the connector and refit the lamp housing and locking pin. Check that the pin is correctly inserted.
2. Check the lighting.

The lamp housing must be plugged in and secured in place before the lighting is switched



Replacing bulbs

on or the remote control key inserted into the ignition switch.

Dipped beam

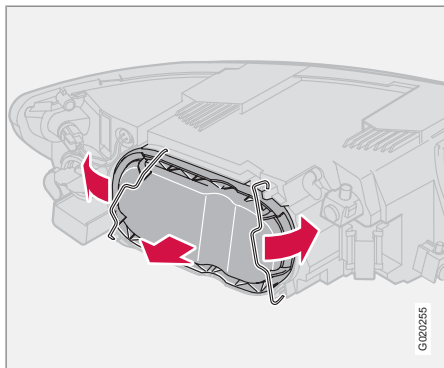

Removing the cover and bulb

1. Remove the entire lamp housing.
2. Bend aside the catches and remove the cover.
3. Release the spring clip securing the bulb. First, press it to the left to release it, then out and down.
4. Pull out the bulb.
5. Refit the lamp housing.

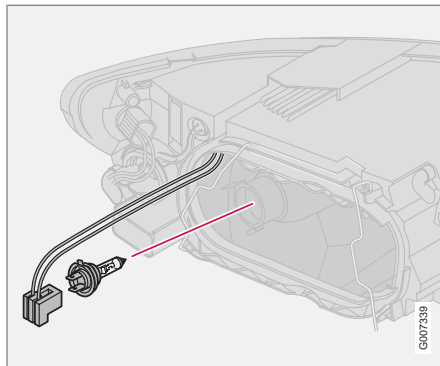

Fitting a new bulb

1. Fit the new bulb. It can only fit in one position.
2. Press the spring clip in/up and then slightly to the right in order to snap it into position.
3. Press the connector back on.
4. Refit the plastic cover.
5. Refit the lamp housing.

Main beam

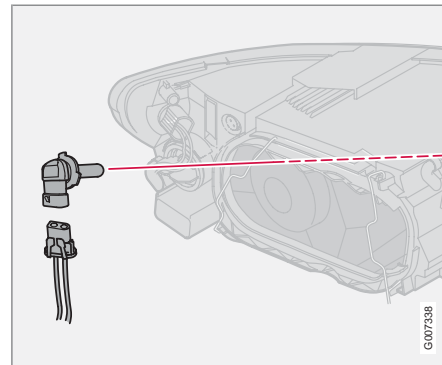

1. Remove the entire lamp housing.
2. Left-hand headlamp:
turn the bulb holder anticlockwise.
Right-hand headlamp:
turn the bulb holder clockwise.
3. Withdraw the bulb holder and change the bulb.
4. Refit the bulb holder. It can only be refitted in one position.
5. Refit the lamp housing.



Replacing bulbs

Position/parking lamps

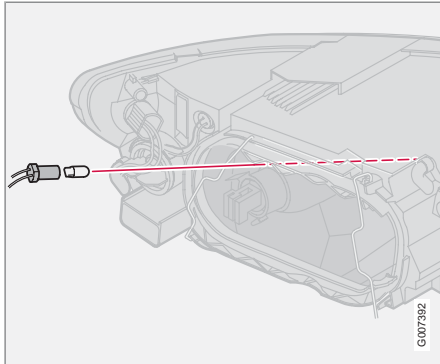

1. Withdraw the bulb holder using pliers. Do not pull out the bulb holder by pulling the electrical cable.
2. Replace the bulb.
3. Press the bulb holder back on. It can only be refitted in one position.

Direction indicators

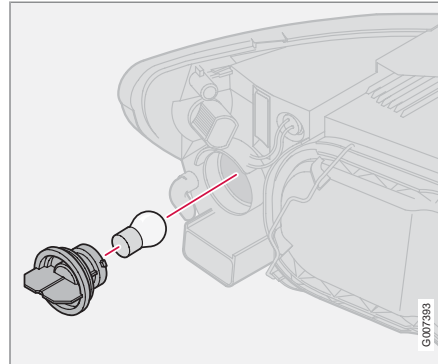

1. Twist the bulb holder anticlockwise and remove it.
2. To remove the bulb from the bulb holder, press the bulb in and turn it anticlockwise.
3. Fit a new bulb and refit the bulb holder into the lamp housing.

Side marker lamps

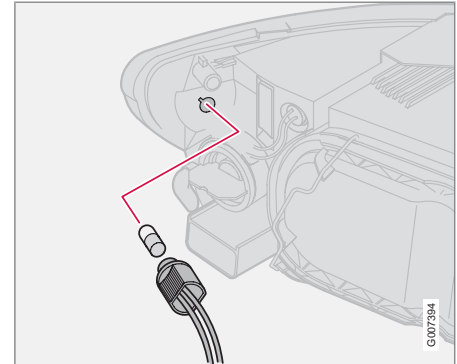

1. Twist the bulb holder anticlockwise and withdraw it. Replace the bulb.
2. Refit the bulb holder. It can only fit in one position.



Replacing bulbs

Front fog lamps

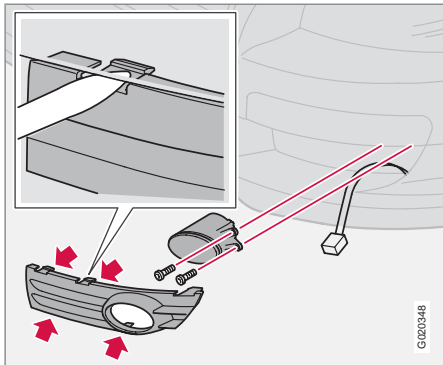

1. Switch off all lights and turn the remote control key to position 0.
2. Remove the panel from around the lamp housing.
3. Remove the two Torx screws securing the lamp housing and take out the lamp housing.
4. Unplug the connector from the bulb.
5. Turn the bulb anticlockwise and pull it out.
6. Fit the new bulb and turn it clockwise.
7. Plug in the connector to the bulb.
8. Secure the lamp housing with the screws and press the panel back into place.

Removing the bulb holder

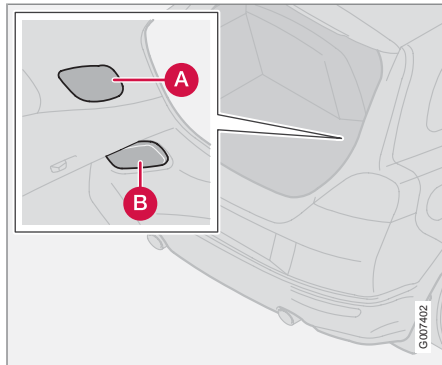

All bulbs in the rear lamp cluster are replaced from inside the cargo area.

1. Switch off all lights and turn the remote control key to position 0.
2. Remove the cover (A or B) in the left/right-hand panel to access the bulbs.
3. The bulbs are located in separate bulb holders.
4. Unplug the connector from the bulb holder.
5. Press the catches together and pull out the bulb holder.
6. Replace the bulb.

7. Plug in the connector.
8. Press the bulb holder into place and refit the cover (A or B).



NOTE

If the error message remains after a faulty bulb has been replaced then we recommend that you visit an authorised Volvo workshop.

Location of the bulbs in the rear light cluster

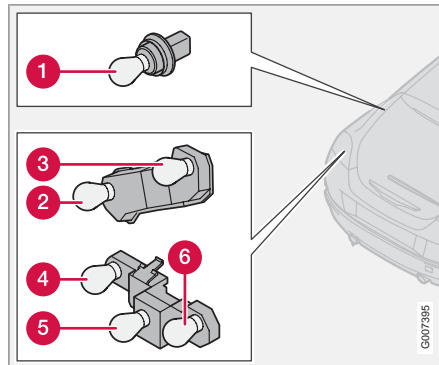

Bulb holder.

Replacing bulbs

- 1 Brake light
- 2 Position/parking and fog lamps
- 3 Position/parking lamps
- 4 Direction indicators
- 5 Reversing lamp
- 6 Position/parking lamps

Number plate lighting

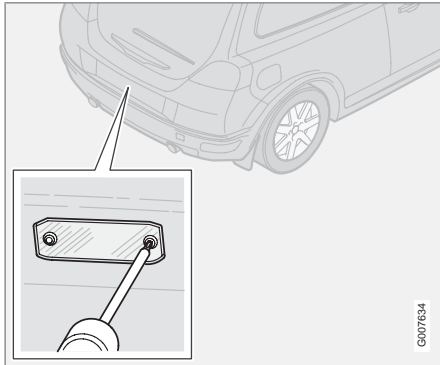

1. Switch off all lights and turn the remote control key to position 0.
2. Remove the screws with a screwdriver.
3. Detach the lens carefully.

4. Replace the bulb.
5. Refit and screw in the lens.

Reflector

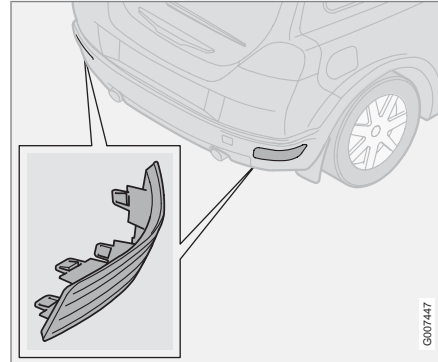

The reflector is secured with clips and is pressed in. It can only fit in one position.

Courtesy lighting

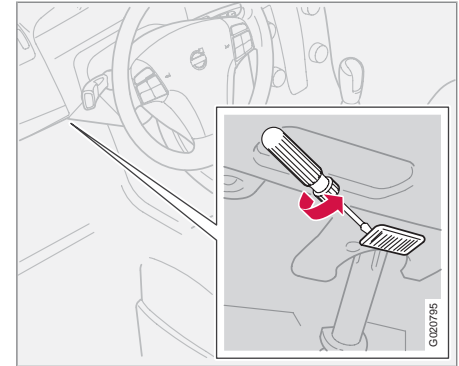

There is courtesy lighting under the instrument panel on the driver and passenger sides.

1. Insert a screwdriver and gently turn so that the lens detaches.
2. Remove the blown bulb.
3. Fit a new bulb.
4. Refit the lens.



Replacing bulbs

Cargo area

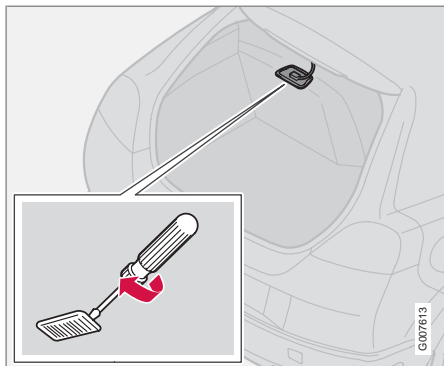

1. Insert a screwdriver and gently turn so that the lamp housing comes loose.
2. Remove the blown bulb.
3. Fit a new bulb.

Passenger compartment lighting in cargo area

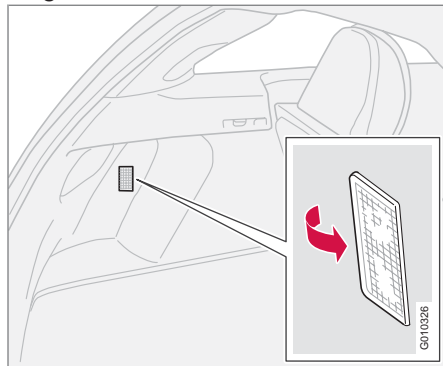

Cargo area lighting also includes a further lamp on the left-hand side of the cargo area.

1. Insert a screwdriver and gently turn so that the lens detaches.
2. Unplug the connector from the bulb holder.

Vanity mirror lighting*

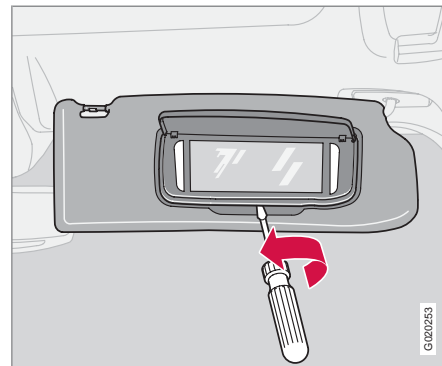

Removing the mirror glass

1. Insert a screwdriver underneath the lower edge, in the centre. Carefully prize up the lug on the edge.
2. Insert the screwdriver underneath the edge on the left and right-hand sides (by the black rubber sections), and prize carefully so that the glass comes loose in the lower edge.
3. Carefully detach and lift aside the entire mirror glass and cover.
4. Remove the blown bulb and replace it with a new one.

**Fitting the mirror glass**

1. First, press the three lugs at top edge of mirror glass back into position.
2. Then press the three lower lugs back into position.



Fuses

General

All electrical functions and components are fused to protect the car's electrical system from damage by short circuiting and overloading.

The fuses are in two different locations in the car:

- Relay/Fuse box in the engine compartment.
- Relay/Fuse box in the passenger compartment.

Changing

If an electrical component or function does not work, it may be because the component's fuse was temporarily overloaded and blew.

1. Look in the fuse diagram to locate the fuse.
2. Pull out the fuse and check from the side to see whether the curved wire has blown.
3. If this is the case, replace it with a new fuse of the same colour and amperage.

Each fuse box has space for several spare fuses. If the same fuse fails repeatedly then there is a fault in the component. In which case, Volvo recommends that you visit an authorised Volvo workshop for this to be checked.



WARNING

Never use a foreign object, or a fuse with an amperage higher than that specified when replacing a fuse. This could cause significant damage to the electrical system and possibly lead to fire.



Relay/fuse box in the engine compartment

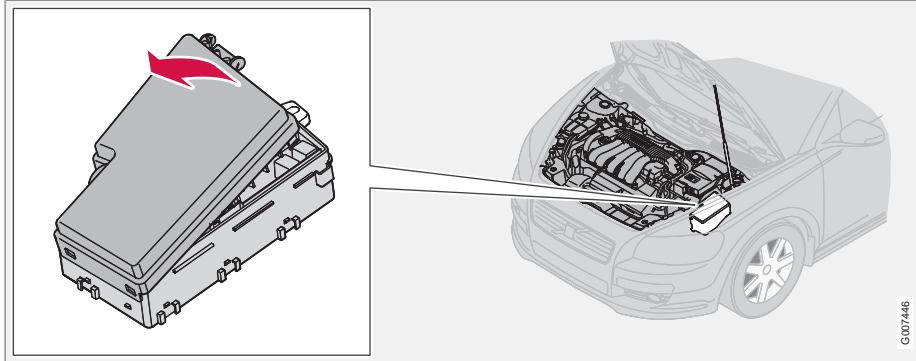

The fuse box has 36 fuse positions. Be sure to replace a blown fuse with a new fuse of the same colour and amperage.

- 19 – 36 are of the "Mini Fuse" type.
- 7-18 are of the "JCASE" type, and for their replacement we recommend that you visit an authorised Volvo workshop.
- 1–6 are of the "Midi Fuse" type and must only be replaced by a workshop. Volvo recommends an authorised Volvo workshop.

On the inside of the cover are tweezers to assist removing and fitting fuses.



09 Maintenance and service

09

Fuses

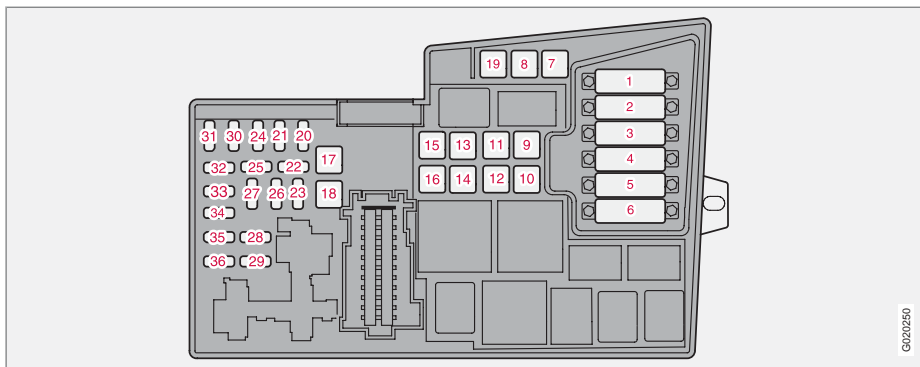

1.	Radiator fan	50 A
2.	Power steering (excl. 1.6 litre engine)	80 A
3.	Supply to passenger compartment fuse box	60 A
4.	Supply to passenger compartment fuse box	60 A
5.	Climate control element, additional heater PTC*	80 A
6.	Glow plugs (4-cyl. diesel)	60 A
	Glow plugs (5-cyl. diesel)	70 A

7.	ABS pump	30 A
8.	ABS valves	20 A
9.	Engine functions	30 A
10.	Ventilation fan	40 A
11.	Headlamp washers	20 A
12.	Supply to heated rear window	30 A
13.	Starter motor relay	30 A
14.	Trailer wiring*	40 A
15.	Reserve	–

16.	Supply to infotainment system	30 A
17.	Windscreen wipers	30 A
18.	Supply to passenger compartment fuse box	40 A
19.	Reserve	–
20.	Horn	15 A
21.	Fuel-driven additional heater, passenger compartment heater*	20 A
22.	Reserve	–



Fuses

23.	Engine control module ECM (5-cyl. petrol), Transmission (TCM) (5-cyl auto)	10 A	33.	Lambda-sond and vacuum pump (5-cyl. petrol), engine control module (5-cyl. diesel), diesel filter heater (4-cyl. diesel)	20 A
	Transmission (TCM) (4-cyl. auto.)	15 A			
24.	Heated fuel filter, PTC element oil trap (5-cyl. diesel)	20 A	34.	Ignition coils (petrol), injectors (1.6 l petrol), fuel pump (4-cyl. diesel), pressure switch, climate control (5-cyl.), glow plugs and EGR emission control (5-cyl. diesel)	10 A
25.	Reserve	–			
26.	Ignition switch	15 A	35.	Engine sensors for valves, relay coil, air conditioning PTC element, oil trap (5-cyl. petrol), engine control module ECM (5-cyl. diesel), canister (petrol), injectors (1.8/2.0 l petrol), MAF mass air flow sensor (5-cyl. petrol, 4-cyl. diesel), turbo control (4-cyl. diesel), pressure switch power steering (1.6 l petrol), EGR emission control (4-cyl. diesel)	15 A
27.	A/C compressor	10 A			
28.	Reserve	–	36.	Engine control module ECM (not 5-cyl. diesel), accelerator pedal position sensor, lambda-sond (5-cyl. diesel))	10 A
29.	Fog lamp, front	15 A			
30.	Engine control module ECM (1.6 l petrol, 2.0 l diesel)	3 A			
31.	Voltage regulator, alternator 4-cyl.	10 A			
32.	Injectors (5-cyl. petrol), lambda-sond (4-cyl. petrol), charge air cooler (4-cyl. diesel), mass air flow sensor and turbo control (5-cyl. diesel)	10 A			



Fuses

Relay/Fuse box in the passenger compartment

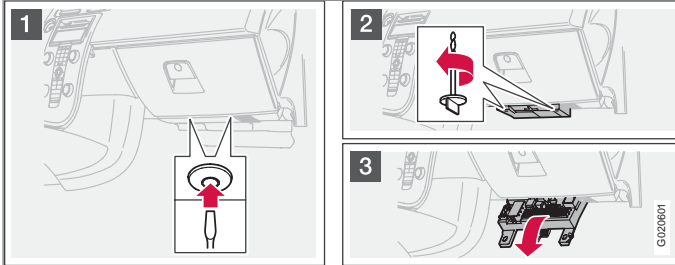

The fuse box has 50 fuse positions. The fuses are located under the glovebox. The box also provides space for several spare fuses. Tools for fuse replacement are located in the relay/fuse box in the engine compartment, see page 219.

Replacing fuses

1. Remove the trim concealing the fuse box by pressing in the pin in the centre of the clips (1) about one cm and then withdrawing the clips.
2. Turn the two wing screws (that secure the fuse box) (2) anticlockwise and remove them.
3. Lower the fuse box (3) half way. Pull it towards the seat until it stops. Lower it

completely. The fuse box can be fully unhooked.

4. Close the fuse box in the reverse order.
5. Remove the pins from the centre of the clips. Fit the trim and the clips. Reinsert the pins into the clips. This expands the clips and secures the trim.



Fuses

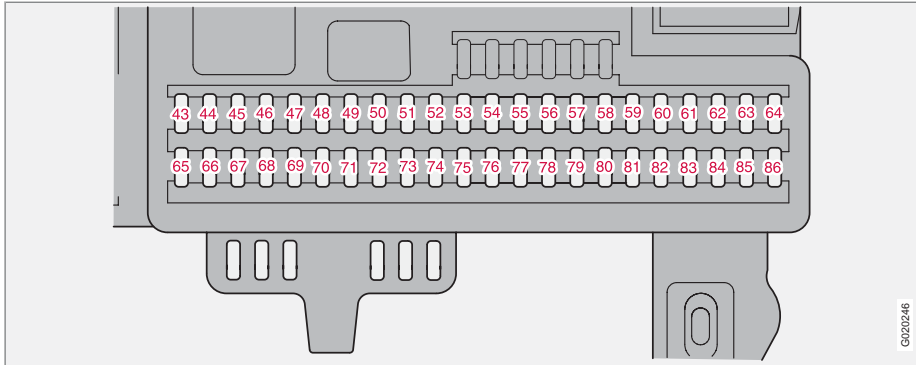

43.	Phone, audio system, RTI*, Bluetooth*	15 A
44.	SRS system, engine control module ECM (5-cyl.)	10 A
45.	Electrical socket, passenger compartment	15 A
46.	Passenger compartment, glovebox and courtesy lighting	5 A
47.	Interior lighting	5 A
48.	Washer, rear window	15 A
49.	SRS system	10 A

50.	Reserve	–
51.	Additional heater for the passenger compartment, fuel filter relay, heating	10 A
52.	Transmission control module (TCM), ABS system	5 A
53.	Power steering	10 A
54.	Parking assistance, Xenon*	10 A
55.	Keyless control module	20 A

56.	Remote control module, siren control module	10 A
57.	Data link connector (DLC), brake light switch	15 A
58.	Main beam (right), auxiliary lamps relay coil	7.5 A
59.	Main beam, left	7.5 A
60.	Seat heating (driver's side)	15 A
61.	Seat heating (passenger side)	15 A
62.	Sunroof	20 A

* Option/accessory, for more information, see Introduction.





Fuses

63.	Reserve	–
64.	Reserve	–
65.	Infotainment system	5 A
66.	Infotainment control module (ICM), climate control	10 A
67.	Reserve	–
68.	Cruise control	5 A
69.	Climate control, rain sensor, BLIS button	5 A
70.	Reserve	–
71.	Reserve	–
72.	Reserve	–
73.	Sunroof, overhead console for interior lighting (OHC), rear seatbelt reminder, autodim mirror	5 A
74.	Fuel pump relay	15 A
75.	Reserve	–
76.	Reserve	–
77.	Reserve	–

78.	Reserve	–
79.	Reversing lamp	5 A
80.	Reserve	–
81.	Reserve	–
82.	Supply to front right door	25 A
83.	Supply to front left door	25 A
84.	Power passenger seat	25 A
85.	Power driver's seat	25 A
86.	Interior lighting, cargo area lighting, power seats, fuel level display (1.8F)	5 A



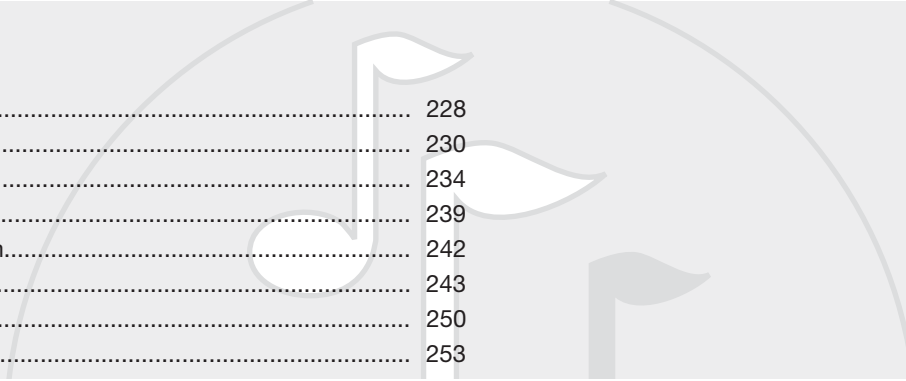

General.....	228
Audio functions.....	230
Radio functions.....	234
CD functions.....	239
Menu structure – audio system.....	242
Phone functions*.....	243
Menu structure – phone*.....	250
Bluetooth handsfree*.....	253

INFOTAINMENT SYSTEM



10





10 Infotainment system

General

Infotainment system

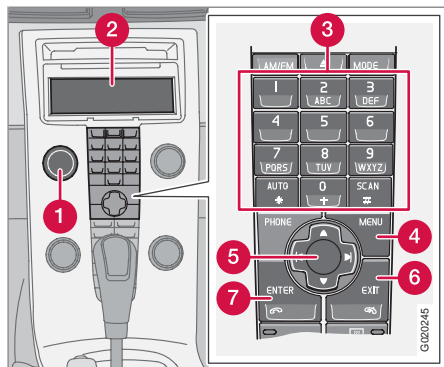

- 1 POWER** - button
- 2** Display
- 3** Keypad
- 4 MENU** - Menu system
- 5** Navigation buttons
- 6 EXIT** - Exits the menu system
- 7 ENTER** - Selects/activates/deactivates

Infotainment is a system that integrates the audio system and phone*. The infotainment system can be easily operated using the con-

trol panel or the steering wheel keypad*, see page 63. The display (2) shows messages and information on the current function.

Audio system

On/Off

POWER (1) starts/switches off the audio system. If the audio system is active when the remote control key is turned to position 0 then it continues to be active until the remote control key is removed from the ignition switch. The audio system is started automatically the next time the remote control key is turned to position I.

Menus

Some infotainment system functions are controlled via a menu system. The current menu level is shown at the top right of the display. Menu options are shown in the middle of the display.

- **MENU** (4) leads to the menu system.
- Up/down with the navigation button (5) moves between menu options.
- **ENTER** (7) selects/activates/deactivates one of the menu options.

- **EXIT** (6) leads back one step in the menu structure. A long press on **EXIT** will exit the menu system.

Shortcuts

Menu options are numbered and can also be selected directly with the keypad (3).

Equipment

The audio system can be equipped with different options and different versions. There are three audio system versions:

- Performance,
- High Performance* or
- Premium Sound*

FM and AM radio with RDS and CD player is however included in each version.

Dolby Surround Pro Logic II®¹

Dolby Surround Pro Logic II® distributes the two stereo audio channels to left, centre, right and rear speakers. This provides a more realistic sound quality than that provided by standard two-channel stereo.



Dolby Surround Pro Logic II® and the Dolby icon are trademarks of Dolby Laboratories Licensing Corporation.

¹ Premium Sound.



General

Dolby Surround Pro Logic II System® is manufactured under license from Dolby Laboratories Licensing Corporation.



Audio functions

Audio controls

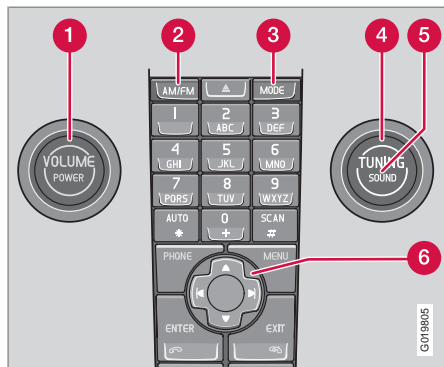

- 1 VOLUME** - Knob
- 2 AM/FM** – Audio source selection
- 3 MODE** - Audio source selection, CD, AUX and USB (e.g. iPod®)¹
- 4 TUNING** - Knob
- 5 SOUND** - Button
- 6** Navigation button - Tuning and menus

Volume

Use **VOLUME** (1) or the steering wheel keypad to regulate the volume, see page 63. Audio vol-

ume adjusts automatically depending on vehicle speed, see page 232.

Audio source selection

Repeatedly pressing **AM/FM** switches between **FM1**, **FM2** and **AM**.

Repeatedly pressing **MODE** switches between **CD**, **USB** and **AUX**.

External audio sources

General

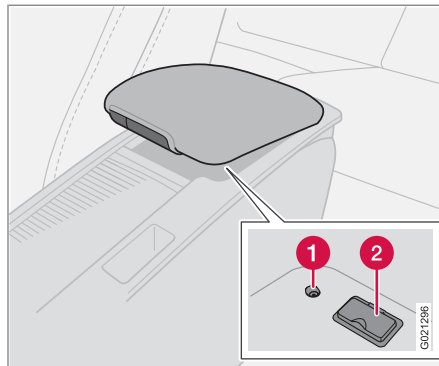

- 1** AUX input
- 2** USB input*

The AUX and USB inputs enable the connection of an external audio source, e.g. an iPod®¹ or MP3 player.

If you choose to connect an iPod®, MP3 player or a USB memory stick to the USB connection then you can control the media via the car's audio controls.

Use the **MODE** button to select the external audio source you wish to use.

1. If **USB** is selected then **Connect device** is shown in the display.
2. Connect your iPod®, MP3 player or USB memory stick to the USB connection in the centre console's storage compartment (see preceding illustration).
 - > The text **Loading** appears on the display when the system loads the file structure on the storage media. This takes a while.

When the loading is finished the track information is shown on the display and it is possible to select the track required.

Track selection can take place in two ways:

1. Select **TUNING** (3) clockwise or anticlockwise

¹ USB only applies for High Performance and Premium Sound. The iPod trademark belongs to Apple Computer Inc.

**Audio functions**

2. or use the navigation control's (4) right or left-hand button to scroll to the required track.

It is also possible to change track using the steering wheel keypad.

In USB or iPod® mode the infotainment system operates in an equivalent way to the CD player for playing back music files. For more information, see page 239.

NOTE

The system supports the playback of music files in the MP3, WMA and WAV file formats. However, there are variants of these file formats that are not supported by the system. The system also supports the majority of iPod® models produced in 2005 or later. iPod® Shuffle is not supported.

USB memory

To facilitate the use of USB memory avoid storing any files other than music files in the memory. It takes considerably longer for the system to load storage media that contains items other than compatible music files.

NOTE

The system supports removable media which is compatible with USB 2.0 and the FAT32 file system, and can handle a maximum of 500 folders and 64 000 files. The memory must have a capacity of at least 256 Mb.

MP3 player

Many MP3 players have their own file systems that are not supported by the audio system. For use in the system, an MP3 player must be set in **USB Removable device/Mass Storage Device mode**.

iPod®

An iPod® is charged and supplied with power by the USB connection via the player's connection cable. However, if the player's battery is completely discharged then it must be charged before the player is connected.

NOTE

When an iPod® is used as audio source, the car's infotainment system has a menu structure that is similar to the iPod® player's own menu structure.

For information on USB and iPod® in combination with Performance audio, see the acces-

sory manual for USB and iPod® Music Interface.

AUX

Sometimes the AUX external audio source can be heard at a different volume to the internal audio sources, e.g. the CD player. If the audio volume of the external audio source is too high then the sound quality can be impaired. Prevent this by adjusting the input volume of the AUX input.

NOTE

The sound quality may be impaired if the player is charged while the audio system is in AUX mode, so avoid charging the player.

Audio settings**Adjusting audio settings**

Press **SOUND** repeatedly to browse among the following options. Adjust by turning **TUNING**.

- **BASS** - Bass level.
- **TREBLE** - Treble level.
- **FADER** - Balance between the front and rear speakers.



Audio functions

- **BALANCE** – Balance between the left and right-hand speakers.
- **CENTRE²** - Level for centre speaker. Three channel stereo or Pro Logic II® must be activated before adjustment is possible, see under the heading Activating/deactivating surround sound below.
- **SURROUND²** - Level for surround. Pro Logic II® must be activated before adjustment is possible, see under the heading Audio settings below.

Surround²



Surround settings govern the spatial perception of the sound. Settings and activating/deactivating are separate for each audio source.

The Dolby® icon in the display indicates that Dolby Pro Logic II® is active. There are three different settings for surround sound:

- **Dolby Pro Logic II**
- **3 channel**
- **Off** - 2 channel stereo.

Activating/deactivating surround sound

1. Press **MENU** and then **ENTER**.
2. Scroll to **Audio settings...** and press **ENTER**.
3. Scroll to **Surround FM...**, **Surround AM...**, **Surround CD...** or **Surround AUX...** and press **ENTER**.
4. Scroll to **Dolby Pro Logic II³**, **3 channel** or **Off** and press **ENTER**.

Equalizer front/rear⁴

The equalizer can be used to adjust different frequency bands separately.

Adjusting equalizer

1. Press **MENU** and then **ENTER**.
2. Scroll to **Audio settings...** and press **ENTER**.
3. Scroll to **Equalizer front...** or **Equalizer rear...** and press **ENTER**.
4. The graphic on the display indicates the audio level of the frequency in question.
5. Adjust the level with **TUNING (4)** or up/down with the navigation button. Addi-

tional frequencies can be selected using the left/right navigation button.

6. Use **ENTER** to save or **EXIT** to close.

Automatic volume control⁵

The auto volume control function allows the audio volume to increase as the speed of the car increases. There are three levels to choose from: **Low**, **Medium** and **High**.

Adjusting automatic volume control

1. Press **MENU** and then **ENTER**.
2. Scroll to **Audio settings...** and press **ENTER**.
3. Scroll to **Auto. volume control...** and press **ENTER**.
4. Scroll to **Low**, **Medium** or **High** and press **ENTER**.

Optimum sound reproduction

The audio system is calibrated for optimum sound reproduction by means of digital signal processing.

This calibration takes into account loudspeakers, amplifiers, passenger compartment

² Premium Sound.

³ Not available in AM and FM mode.

⁴ Certain audio systems.

⁵ Not Performance Sound.



Audio functions

acoustics, listener position etc. for each combination of car model and audio system.

There is also a dynamic calibration that takes into account the position of the volume control, radio reception and vehicle speed.

The controls explained in these operating instructions, e.g. bass, treble and equalizer* are only intended for the user to be able to adapt the sound reproduction according to personal taste.



Radio functions

Radio controls

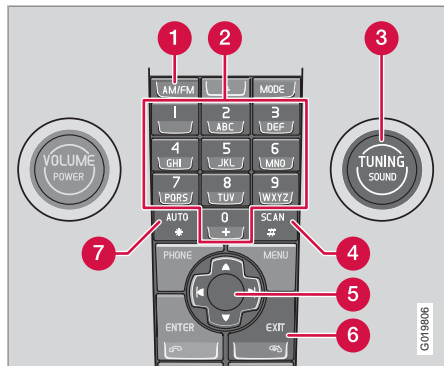

- 1 **FM/AM** – Wavelength selection
- 2 Station presets
- 3 **TUNING** – Knob for station searches
- 4 **SCAN** – Scanning
- 5 Navigation button - Tuning and menus
- 6 **EXIT** - Cancel current function
- 7 **AUTO** – Automatic storage of stations

Tuning

Automatic tuning

1. Select wavelength using **AM/FM** (1).
2. Give a brief press on or .

Manual tuning

1. Select wavelength using **AM/FM** (1).
2. Adjust the frequency by turning **TUNING** (3).

Tune into a station with a long press on or . Or by using the steering wheel keypad:

- Hold in or on the navigation button depressed until the desired frequency appears on the display.

As long as the frequency graphic appears on the display, searching can be resumed by briefly pressing or .

Storing stations

Ten station presets can be stored per wavelength. FM has two memories for presets: **FM1** and **FM2**. Preset stations are selected using the preset buttons (2) or the steering wheel keypad.

Storing stations manually

1. Tune into a station.

2. Hold a station preset button depressed until the message **Station stored** appears on the display.

Automatic storage of stations

AUTO (7) seeks out the ten strongest radio stations and stores them automatically in a separate memory. The function is especially useful in areas where the radio stations and their frequencies are unfamiliar.

Starting automatic storage of stations

1. Select wavelength using **AM/FM** (1).
2. Hold **AUTO** (7) depressed until **Autostoring** appears on the display.

Once **Autostoring** disappears from the display, the stations are stored. The radio continues in Auto mode and **Off** appears on the display. The automatically stored presets can now be selected using the preset buttons (2).

Cancelling automatic storage of stations

- Press **EXIT** (6).

Selecting an auto-stored preset

Allowing the radio to remain in Auto mode provides access to the autostored presets.

1. Briefly press **AUTO** (7).
 - > **Auto** appears on the display.
2. Press a preset button (2).



Radio functions

- > The radio remains in Auto mode until it is exited by a brief press on **AUTO** (7), **EXIT** (6) or **AM/FM** (1).

Storing autostored presets in another memory

An autostored preset can be transferred to the FM or AM memory.

- Briefly press **AUTO** (7).
 - > **Auto** appears on the display.
- Press a preset button.
- Press the button under which the station will be stored and hold it depressed until the message **Station stored** appears on the display.
 - > The radio exits Auto mode and the stored station can be selected as a preset.

Scanning

SCAN (4) automatically searches through a wavelength for strong stations. When a station is found, it is played for approx. 8 seconds before scanning is resumed.

Activating/deactivating Scan

- Select wavelength using **AM/FM**.
- Press **SCAN** to activate.
 - > **SCAN** appears on the display. Close using **SCAN** or **EXIT**.

Storing a station

A selected station can be stored as a preset while **SCAN** is active.

- Press a station preset button and hold it depressed until the message **Station stored** appears on the display.
 - > Scanning is interrupted and the stored station can be selected as a preset.

RDS functions

Radio Data System - RDS links FM transmitters into a network. An FM transmitter in such a network sends information that gives an RDS radio the following functions:

- Automatically switches to a stronger transmitter if reception in the area is poor.
- Searches for programme form, such as traffic information or news.
- Receives text information on current radio programme.

Some radio stations do not use RDS or only some of its functionality.

Programme functions

In FM mode, the radio can search for stations with certain programme types. If a required programme type is located the radio can switch stations interrupting the audio source currently in use. For example, if the CD player is in use, it is paused. The interrupting transmission is played at a preset audio volume, see page 238. The radio returns to the previous audio source and audio volume when the set programme type is no longer broadcast.

The programme functions alarm (**ALARM!**), traffic information (**TP**), news (**News**), and programme types (**PTY**) interrupt one another in order of priority, where alarm has the highest priority and programme types has the lowest.

For further programme interruption settings, see EON and REG see page 237. The programme functions are modified via the menu system, see page 228.

Returning to the interrupted audio source

Press **EXIT** to return to the interrupted audio source.

Alarm

This function is used to warn of serious accidents and catastrophes. The alarm cannot be temporarily interrupted or deactivated. The



Radio functions

message **ALARM!** appears on the display when an alarm message is transmitted.

Traffic information – TP

 This function allows traffic information broadcast within a set station's RDS network to break through. **TP** shows that the function has been activated. If the set station can send traffic information then **TP** appears on the display.

Activating/deactivating TP

1. Press **MENU** and then **ENTER**.
2. Scroll to **TP** and press **ENTER**.

TP from current station/all stations

The radio can interrupt with traffic information from only the set (current) station or from all stations.

1. Select an FM station.
2. Press **MENU** and then **ENTER**.
3. Scroll to **Advanced radio settings...** and press **ENTER**.
4. Scroll to **TP** and press **ENTER**.
5. Scroll to **TP station...** and press **ENTER**.
 - > Either **TP from current station** or **TP from all stations** is shown on the display.
6. Press **ENTER**.

Activating/deactivating TP search

TP search is useful during long journeys while an audio source other than the radio is being played. The function automatically searches for traffic information within different RDS networks.

1. Press **MENU** and then **ENTER**.
2. Scroll to **Advanced radio settings...** and press **ENTER**.
3. Scroll to **TP** and press **ENTER**.
4. Scroll to **TP search** and press **ENTER**.

News

 This function allows news broadcasts within a set station's RDS network to break through. The message **News** shows that the function is active.

Activating/deactivating News

1. Press **MENU** and then **ENTER**.
2. Scroll to **News** and press **ENTER**.

News from current station/all stations

The radio can interrupt with news from only the set (current) station or from all stations.

1. Select an FM station.
2. Press **MENU** and then **ENTER**.

3. Scroll to **Advanced radio settings...** and press **ENTER**.
4. Scroll to **News station...** and press **ENTER**.
 - > Either **Press ENTER to receive news from this station only**, or **News from all stations** is shown on the display.
5. Press **ENTER**.

Programme types – PTY

 The PTY function can be used to select different programme types, such as **Pop music** and **Serious classic**. The PTY symbol indicates that the function is active. This function allows programme types broadcast within a set station's RDS network to break through.

Activating/deactivating PTY

1. Select **FM1** or **FM2** with **FM/AM**.
2. Press **MENU** and then **ENTER**.
3. Scroll to **PTY** and press **ENTER**.
4. Scroll to **Select PTY...** and press **ENTER**.
 - > A list of programme types appears: **Current affairs**, **Information** etc. The PTY function is activated by selecting programme types and deactivated by clearing all PTYs.



Radio functions

5. Select the desired programme types or **Clear all PTY...**

Search PTY

This function searches the entire wavelength for the selected programme type.

1. Activate PTY.
2. Press **MENU** and then **ENTER**.
3. Scroll to **PTY** and press **ENTER**.
4. Scroll to **Search PTY** and press **ENTER**.

If the radio finds any of the selected programme types, then > appears on the display. Press the navigation button  to continue searching for another broadcast of the selected programme types.

Display of programme type

The programme type of the current station can be shown on the display.

NOTE

Not all radio stations support this function.

Activating/deactivating display

1. Press **MENU** and then **ENTER**.
2. Scroll to **PTY** and press **ENTER**.

3. Scroll to **Show PTY** and press **ENTER**.

Radio text

Some RDS stations transmit information on programme content, artists, etc. This information can be shown on the display.

Activating/deactivating radio text

1. Press **MENU** and then **ENTER**.
2. Scroll to **Radio text** and press **ENTER**.

Automatic frequency update – AF

The AF function selects one of the strongest transmitters for a set station. The radio may sometimes need to search through the entire FM wavelength to find a strong transmitter. If this occurs, the radio mutes and **PI Seek Press EXIT to cancel.** appears in the display.

Activating/deactivating AF

1. Press **MENU** and then **ENTER**.
2. Scroll to **Advanced radio settings...** and press **ENTER**.
3. Scroll to **AF** and press **ENTER**.

Regional radio programmes – REG



This function causes the radio to continue with a regional transmitter even if its signal strength is low.

Regional indicates that the function is active. The regional function is normally deactivated.

Activating/deactivating REG

1. Press **MENU** and then **ENTER**.
2. Scroll to **Advanced radio settings...** and press **ENTER**.
3. Scroll to **Regional** and press **ENTER**.

Enhanced Other Networks – EON

The EON function is especially useful in urban areas with many regional radio stations. It allows the distance between the car and the radio station transmitter to determine when programme functions should interrupt the current audio source.

- **Local** – interrupts only if the radio station transmitter is close.
- **Distant**¹ – interrupts if the station transmitter is far away, even if there is a lot of static.
- **Off** – no interruption for programmes from other transmitters.

¹ Factory sett.



Radio functions

Activating/deactivating EON

1. Press **MENU** and then **ENTER**.
2. Scroll to **Advanced radio settings...** and press **ENTER**.
3. Scroll to **EON...** and press **ENTER**.
4. Scroll to **Local**, **Distant** or **Off** and press **ENTER**.

Resetting RDS functions

Resets all radio settings to the original factory settings.

1. Press **MENU** and then **ENTER**.
2. Scroll to **Advanced radio settings...** and press **ENTER**.
3. Scroll to **Reset all...** and press **ENTER**.

Volume control, programme types

The interrupting programme types are heard at the volume selected for each programme type. If the volume level is adjusted during the programme interruption, the new level is saved until the next programme interruption.



CD functions

CD function controls

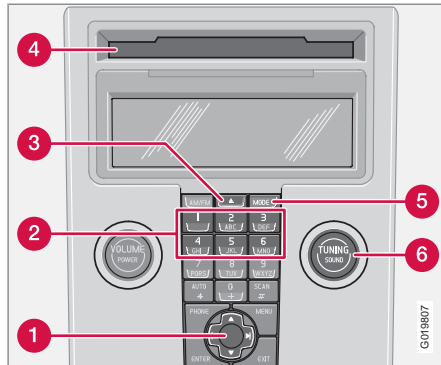

- 1 Navigation button – Fast forward/rewind, track selection and menus
- 2 CD changer position selection*
- 3 CD insertion/eject
- 4 CD insertion/eject slot
- 5 **MODE** - Audio source selection CD or AUX*
- 6 **TUNING** - Knob for track selection

Starting playback (CD player)

If a music CD is in the player when the audio system is in CD mode then playback is started

automatically. Otherwise, load a disc and change to CD mode by pressing **MODE**.

Starting playback (CD changer*)

If a CD position with a music CD is already selected when the audio system is activated then playback starts automatically. Otherwise change to CD changer mode using **MODE** and select a disc with the number buttons **1–6** or Up/Down on the navigation button.

Insert a CD

1. Select an empty position with buttons **1–6** or Up/Down on the navigation button.
 - > An empty position is marked on the display. The text **Insert disc** shows that a new disc can be inserted. The CD changer can hold up to 6 CD discs.
2. Inserting a CD in the CD changer.

CD eject

A CD will stay in the ejected position for approx. 12 seconds. Following which it is re-inserted in the player and playback continues.

Eject individual discs by pressing the eject button **3**.

Eject all discs with a long press on the eject button. The entire magazine is emptied disc by disc. The message **Eject all** is shown in the display.

Pause

If the volume is turned down completely, the CD player is stopped. The player is restarted when volume is increased.

Audio files*

The CD player also supports MP3 and WMA format audio files.

NOTE

Certain types of copy-protected audio files cannot be read by the player.

When a CD containing audio files is inserted into the player the disc's directory structure is read in. It may take a while before playback starts due to the quality of the disc.

Navigation and playback

If a disc containing audio files is inside the CD player then **ENTER** displays the disc's directory structure. The directory structure is navigated in the same way as the audio system's menu structure. Audio files have the symbol and directories have the symbol . Start audio file playback with **ENTER**.

When the playback of a file is finished the playback of the other files in the same directory continues. Directory change takes place auto-



CD functions

matically when all files in the current directory have been played back.

Press left/right on the navigation button if the display is not wide enough to show the whole audio file name.

Fast-wind/change CD tracks and audio files

Short presses right/left on the navigation button are used to scroll between CD tracks/audio files. Long presses are used to fast-wind CD tracks/audio files. **TUNING** (or the steering wheel keypad) can also be used for this purpose.

Scan CD

This function plays the first 10 seconds of each CD track/audio file. Press **SCAN** to activate. Interrupt with **EXIT** or **SCAN** to continue playback of the current CD track/audio file.

Random

This function plays the tracks in random order. The random CD tracks/audio files can be scrolled through in the normal way.



NOTE

It is only possible to scroll between random CD tracks on the current disc.

Different messages appear on the display depending on which random function has been selected.

- **RANDOM** means that the tracks from only one music CD are played
- **RND ALL** means that all tracks on all music CDs in the CD changer are played.
- **RANDOM FOLDER** means that the audio files in a directory on the current CD are played.

Activating/deactivating (CD player)

If a normal music CD is being played:

1. Press **MENU** and then **ENTER**.
2. Scroll to **Random** and press **ENTER**.

If a disc with audio files is being played:

1. Press **MENU** and then **ENTER**.
2. Scroll to **Random** and press **ENTER**.
3. Scroll to **Folder** or **Disc** and press **ENTER**.

Activating/deactivating (CD changer)

If a normal music CD is being played:

1. Press **MENU** and then **ENTER**.
2. Scroll to **Random** and press **ENTER**.

3. Scroll to **Single disc** or **All discs** and press **ENTER**.

The option **All discs** only applies to the music CDs in the changer.

If a CD with audio files is being played:

1. Press **MENU** and then **ENTER**.
2. Scroll to **Random** and press **ENTER**.
3. Scroll to **Single disc** or **Folder** and press **ENTER**.

The function is deactivated when another CD is selected.

Disc text

If title information is stored on a music CD then it can be shown on the display¹.

Activating/deactivating

1. Start CD playback.
2. Press **MENU** and then **ENTER**.
3. Scroll to **Disc text** and press **ENTER**.

CDs

Using low quality CD discs could result in poor or non-existent sound.

¹ Applies to CD changer.



CD functions



IMPORTANT

Only use standard discs (12 cm in diameter). Do not use CD discs with adhesive disc labels. The heat in the CD player may cause the label to come off, damaging the CD player.



Menu structure – audio system

Overview

FM menu

1. News
2. TP
3. PTY
4. Radio text
5. Advanced radio settings
6. Audio settings*

AM menu

1. Audio settings*

CD menu

1. Random
2. News
3. TP
4. Disc text
5. Audio settings*

CD changer menu

1. Random
2. News
3. TP
4. Disc text
5. Audio settings*

AUX menu

1. AUX volume
2. News
3. TP
4. Audio settings*



Phone functions*

Overview - Phone system components

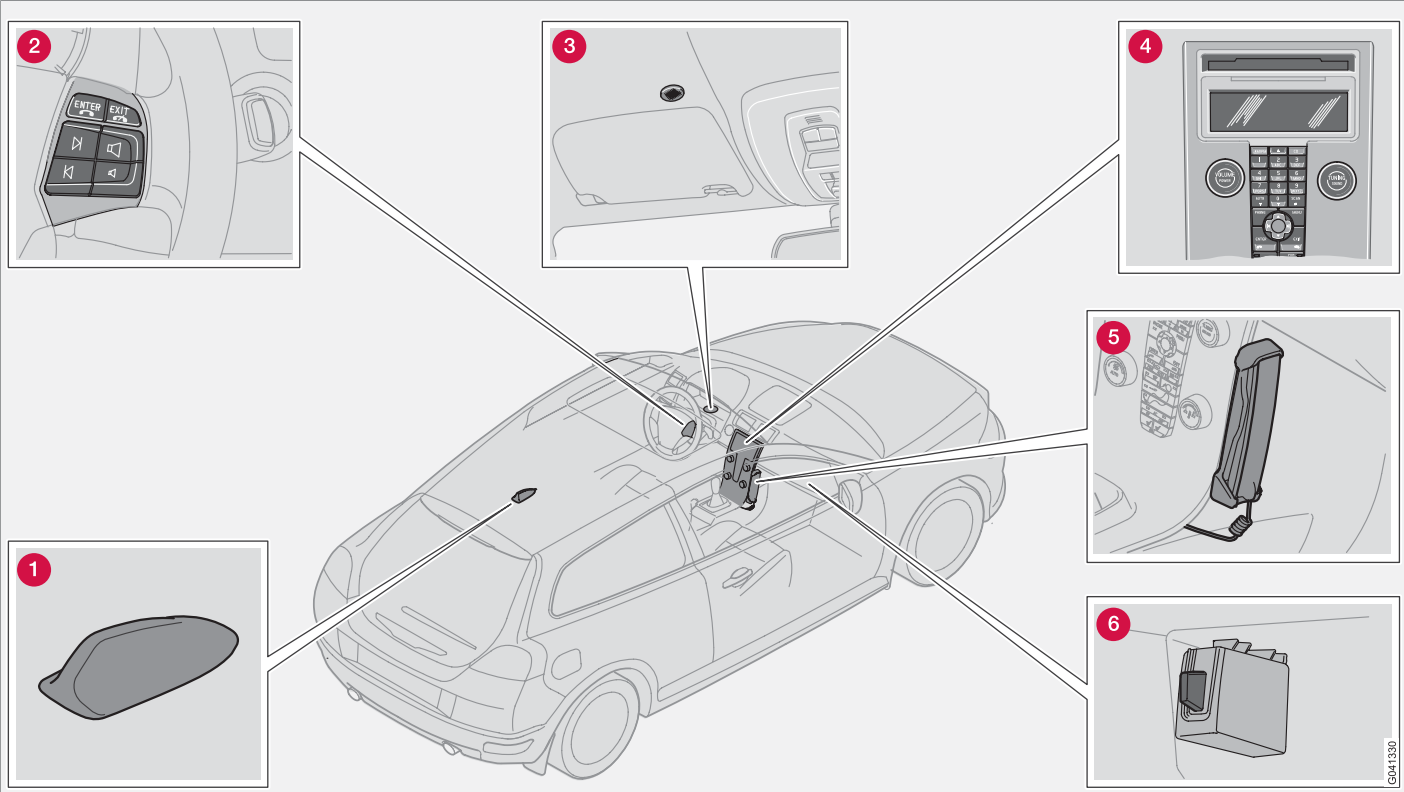

* Option/accessory, for more information, see Introduction.





10 Infotainment system

Phone functions*

Phone system components

1. Antenna

2. Steering wheel keypad

Most phone system functions can be accessed via the keypad. see page 245.

3. Microphone

The hands free microphone is integrated in the roof console beside the rearview mirror.

4. Centre console control panel

All phone functions (except call volume) can be regulated via the control panel.

5. Privacy handset

6. SIM card reader

General

- Always put traffic safety first.
- If the driver needs to use the privacy handset, park the car in a safe place first.
- Switch off the phone system when refueling the car.
- Switch off the system near blasting work.
- Volvo recommends that an authorised Volvo workshop carries out phone system servicing.

Emergency calls

Emergency calls to alarm centres can be made without a SIM card as long as there is coverage by a GSM operator.

Making an emergency call

1. Activate the phone.
2. Ring the emergency number that applies to your region (within EU: 112).
3. Press **ENTER**.

IDIS

The IDIS system (Intelligent Driver Information System) allows incoming phone calls and SMS messages to be delayed so that the driver can concentrate on driving. Incoming calls and SMS messages can be delayed 5 seconds before they are connected. Missed calls are shown on the display. IDIS can be deactivated using menu function 5.5, see page 250.

SIM card

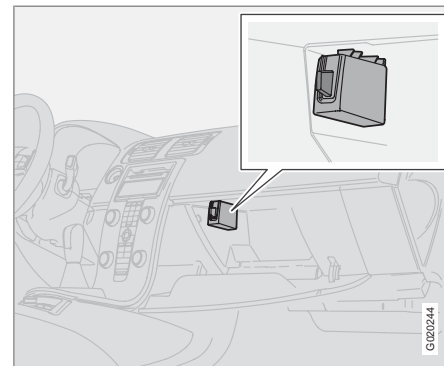

The phone can only be used with a valid SIM card Subscriber Identity Module. Cards are available from various network operators. Contact your network operator if you experience difficulties with the SIM card.

i NOTE

The built-in phone cannot read 3G type SIM cards (3G only). Combined 3G/GSM cards work. Contact your network operator if you need to change your SIM card.



Phone functions*

Double SIM cards

Many network operators offer two SIM cards for the same phone number. The extra SIM card can be used in the car.

Inserting the SIM card

1. Switch off the phone and open the glove-box.
2. Pull out the SIM card holder from the SIM card reader, see illustration on page 244.
3. Position the SIM card in the holder with the metal surface visible. The bevelled edge of the SIM card should align with the bevel of the SIM card holder.
4. Carefully press in the SIM card holder.

Menus

Page 250 describes how to control phone functions with the menu system.

Traffic safety

For safety reasons, parts of the phone menu system cannot be accessed at speeds in excess of 8 km/h.

Phone controls

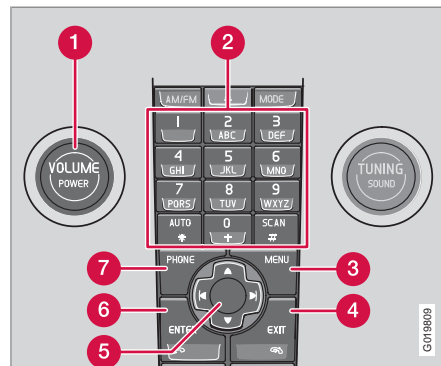

Centre console control panel.

- 1 **VOLUME** - Control the background volume from the radio, for example, during a call
- 2 Number and letter buttons
- 3 **MENU** - Opens the main menu
- 4 **EXIT** - End/refuse calls, clear entered characters
- 5 Navigation button – Scroll in menus and character rows
- 6 **ENTER** – Accept calls. A press of the button reveals latest dialled numbers
- 7 **PHONE** - On/off and standby mode

Steering wheel keypad

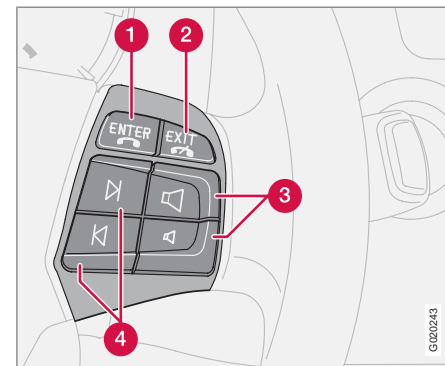

When the phone is active, the steering wheel keypad is locked to phone functions. To control the audio system, the phone must be in standby mode (standby).

- 1 **ENTER** – Works the same as on the control panel
- 2 **EXIT** – Works the same as on the control panel
- 3 Call volume – Increase/decrease
- 4 Navigation buttons – Scroll in menus



Phone functions*

On/Off

A handset appears in the display when the phone system is active or in standby mode (standby). If the remote control key is turned to position **0** when the phone is in one of these modes, the phone automatically resumes this mode the next time the remote control key is turned to position **I** or **II**.

Activating the phone system

Phone system functions can only be used when the phone is in active mode.

1. Press **PHONE**.
2. Enter the PIN code (if necessary) and press **ENTER**.

Deactivating the phone system

No calls can be received when the phone is deactivated.

- Hold **PHONE** depressed until the phone is deactivated.

Standby mode (standby)

In standby mode, the audio system can be in use while calls are received. However, it is not possible to make calls when in standby mode.

Putting the phone in standby mode

The phone must first be in active mode before it can be put in standby mode.

- Press **PHONE**.

Activating from standby mode

- Press **PHONE**.

Making and receiving calls

If the privacy handset is raised when a phone call is started, the sound will come from the handsfree system. For information on switching between privacy handset and handsfree during a call, see page 248.

To call

1. Activate the phone system (if necessary).
2. Dial the number or use the phone book, see page 248.
3. Press **ENTER** or lift the handset. Release the handset by pressing it down.

Receiving a call

For Auto answer, see menu option 4.3, see page 250.

- Press **ENTER** or lift the handset. Release the handset by pressing it down.

Ending a call

- Press **EXIT** or hang up the handset.

Refusing a call

- Press **EXIT**.

Call waiting

A two-tone signal during a phone call indicates that there is another incoming call. **Answer?** appears on the display. The call can be refused or taken in the normal manner. If the incoming call is taken, the previous call is put on hold.

Putting a call on hold/resuming a call

1. Press **MENU** or **ENTER**.
2. Scroll to **Hold** or **Hold off** and press **ENTER**.

Dialling a third party

1. Put the call on hold.
2. Dial the number of the third party.

Switching between calls

1. Press **MENU** or **ENTER**.
2. Scroll to **Swap** and press **ENTER**.

Starting a conference call

A conference call consists of at least three parties that can talk to one another. Once a conference call has been initiated, no more parties can be connected. All calls are ended when a conference call is ended.

1. Start two phone calls.
2. Press **MENU** or **ENTER**.
3. Scroll to **Join** and press **ENTER**.



Phone functions*

Volume

The phone uses the driver's door speaker.

Call volume



Call volume is regulated with the steering wheel keypad.

If the privacy handset is used, volume is regulated with a wheel on the side of the handset.

Audio system volume

Audio system volume is temporarily lowered during a phone call. Once the call is ended the previous volume is resumed. If the volume is regulated during the call, the new level is retained once the call is ended. Sound can also be automatically muted during a phone call, see menu 5.4.3, on page 252. This function only applies to the Volvo integrated phone system.

Entering text

Text is entered using the phone keypad.

1. Press the key with the desired character - once for the first character on the button, twice for the second, etc. See table.
2. Press **1** for a space. If two characters in a row are to be entered using the same button, press ***** or wait a few seconds.

A short press on **EXIT** deletes an input character. A long press on **EXIT** will clear all entered characters.

Key	Function
1	space 1 - ? ! , . : " ' ()
2 ABC	a b c 2 ä å à æ ç
3 DEF	d e f 3 è é
4 GHI	g h i 4 ì
5 JKL	j k l 5
6 MNO	m n o 6 ñ ò ø
7 PQRS	p q r s 7 ß
8 TUV	t u v 8 ü ù
9 WXYZ	w x y z 9
AUTO *	Pressed briefly if two characters shall be entered after each other with the same key.

Key	Function
0 +	+ 0 @ * # & \$ £ / %
SCAN #	Switch between upper and lower case.

Handling numbers

Calling the last number dialed

The phone automatically stores the last phone numbers dialed.

1. Press **ENTER**.
2. Scroll to a number and press **ENTER**.

Phone book

If the phone book contains a live caller's contact information then this is shown in the display. Contact information can be stored on the SIM card and in the phone.

Storing contacts in the phone book

1. Press **MENU**.
2. Scroll to **Phonebook** and press **ENTER**.
3. Scroll to **New number** and press **ENTER**.
4. Enter a name and press **ENTER**.
5. Enter a number and press **ENTER**.
6. Scroll to **SIM card** or **Phone** and press **ENTER**.



Phone functions*

Searching for contacts in the phone book

Use the down arrow of the navigation button instead of **MENU** for direct access to the **Search** menu.

1. Press **MENU**.
2. Scroll to **Phonebook** and press **ENTER**.
3. Scroll to **Search** and press **ENTER**.
4. Enter the first few letters of the item and press **ENTER**, or simply press **ENTER**.
5. Scroll to an item and press **ENTER**.

Copying entries between the SIM card and Phone book

1. Press **MENU**.
2. Scroll to **Phonebook** and press **ENTER**.
3. Scroll to **Copy all** and press **ENTER**.
4. Scroll to **SIM to phone** or **Phone to SIM** and press **ENTER**.

Deleting contacts from the phone book

1. Press **MENU**.
2. Scroll to **Phonebook** and press **ENTER**.
3. Scroll to **Search** and press **ENTER**.
4. Enter the first few letters of the item and press **ENTER**, or simply press **ENTER**.
5. Scroll to the item to be erased and press **ENTER**.

6. Scroll to **Delete** and press **ENTER**.

Erase all contacts

1. Press **MENU**.
2. Scroll to **Phonebook** and press **ENTER**.
3. Scroll to **Erase SIM** or **Erase phone** and press **ENTER**.

If required, enter phone code. The factory-set default code is 1234.

Speed dial

A keypad button (1–9) can be used as a speed dial number for a contact in the phone book.

1. Press **MENU**.
2. Scroll to **Phonebook** and press **ENTER**.
3. Scroll to **Speed dial** and press **ENTER**.
4. Scroll to **Select numbers** and press **ENTER**.
5. Scroll to the digit of the keypad button for the speed dial number and press **ENTER**.
6. Enter the first few letters of the item and press **ENTER**, or simply press **ENTER**.
7. Scroll to an item and press **ENTER**.
8. Hold **EXIT** depressed to leave the menu system.

Calling using speed dial

- Briefly press the required keypad button, followed by **ENTER**.

NOTE

When the phone is switched on, it takes a while before speed dialling is available.

To use the speed dial function **Speed dial** must be activated in the **Phonebook** menu, see page 251.

Calling from the phone book

1. Press **MENU**.
2. Scroll to **Phonebook** and press **ENTER**.
 - > All contacts in the phone book memory are displayed. The number of contacts displayed can be reduced by entering part of the contact's name.
3. Scroll to a contact and press **ENTER**.

NOTE

Press **ENTER** to dial.



Phone functions*

NOTE

Hold in the required letter/button in the keypad for about 2 seconds to reach the corresponding letter in the phone book.

Functions during a call

Several functions are available during a call. Some functions can only be used when a call is on hold.

Press **MENU** or **ENTER** during a call to access the In-call menu and scroll to one of the following alternatives:

1. **Mute/Mute off** – Mute mode.
2. **Hold/Resume** - Put a call on hold or resume a call.
3. **Handsfree/Handset** - Use handsfree or the privacy handset.
4. **Phonebook** – Show phone book.
5. **Join** – Conference calling (available if more than three parties are connected)
6. **Swap** – Switch between two calls (available if up to three parties are connected).

SMS - Short Message Service**Reading SMS**

1. Press **MENU**.
2. Scroll to **Messages** and press **ENTER**.
3. Scroll to **Read** and press **ENTER**.
4. Scroll to a message and press **ENTER**.
 - > The message text is shown in the display. Additional selections can be made by pressing **ENTER**. Hold **EXIT** depressed to leave the menu system.

Writing and sending

1. Press **MENU**.
2. Scroll to **Messages** and press **ENTER**.
3. Scroll to **Write new** and press **ENTER**.
4. Enter text and press **ENTER**.
5. Scroll to **Send** and press **ENTER**.
6. Enter a phone number and press **ENTER**.

IMEI number

To block the phone, you must provide your network operator with the phone's IMEI number. This is a 15 digit serial number that is programmed into the phone. Dial *#06# to show this number in the display. Write it down and keep it in a safe place.

Specifications

Output	2 W
SIM card	Small
Memory entries	250 ^A
SMS (Short Message Service)	Yes
Data/Fax	No
Dualband (900/1800 MHz)	Yes

^A The capacity of the SIM card's memory varies depending on SIM card type.



Menu structure – phone*

Phone menu

1. Call register

- 1.1. Missed calls
- 1.2. Received calls
- 1.3. Dialed no.
- 1.4. Erase list
 - 1.4.1. All calls
 - 1.4.2. Missed calls
 - 1.4.3. Received calls
 - 1.4.4. Dialed no.
- 1.5. Call duration
 - 1.5.1. Last call
 - 1.5.2. Call count
 - 1.5.3. Total time
 - 1.5.4. Reset timers

2. Phonebook

- 2.1. New number
- 2.2. Search
- 2.3. Copy all
 - 2.3.1. SIM to phone
 - 2.3.2. Phone to SIM

- 2.4. Speed dial
 - 2.4.1. Active
 - 2.4.2. Select numbers
- 2.5. Erase SIM
- 2.6. Erase phone
- 2.7. Memory status

3. Messages

- 3.1. Read
- 3.2. Write
- 3.3. Message settings
 - 3.3.1. SMSC number
 - 3.3.2. Validity time
 - 3.3.3. Message type

4. Call options

- 4.1. Send my no.
- 4.2. Call waiting
- 4.3. Automatic answer
- 4.4. Auto redial
- 4.5. Voice mail number
- 4.6. Call divert
 - 4.6.1. All calls
 - 4.6.2. When engag.

- 4.6.3. Not answered
- 4.6.4. Not reachable
- 4.6.5. Fax calls
- 4.6.6. Data calls
- 4.6.7. Cancel all

5. Tel. settings

- 5.1. Network
 - 5.1.1. Auto
 - 5.1.2. Manual select
- 5.2. SIM security
 - 5.2.1. On
 - 5.2.2. Off
 - 5.2.3. Auto
- 5.3. Change code
 - 5.3.1. PIN code
 - 5.3.2. Phone code
- 5.4. Audio
 - 5.4.1. Ring volume
 - 5.4.2. Ring signal
 - 5.4.3. Mute radio
 - 5.4.4. Msg. beep
- 5.5. IDIS

**Menu structure – phone***

5.6 Factory settings

Description of menu options**1. Call register****1.1. Missed calls**

List of missed calls. You can choose to call, erase or store the number in the phone book.

1.2. Received calls

List of received calls. You can choose to call, erase or store the number in the phone book.

1.3. Dialed no.

List of dialled numbers. You can choose to call, erase or store the number in the phone book.

1.4. Erase list

Erase the lists found in the menus 1.1, 1.2 and 1.3 as below.

1.4.1. All calls

1.4.2. Missed calls erased

1.4.3. Received calls erased

1.4.4. Dialed calls erased

1.5. Call duration

Duration of all calls or of the most recent call. To reset the call timer, see menu 1.5.4.

1.5.1. Last call

1.5.2. Call count

1.5.3. Total time

1.5.4. Reset timers

2. Phone book**2.1. New number**

Store names and phone numbers in the phone book, see page 247.

2.2. Search

Search for a name in the phone book.

2.3. Copy all

Copy phone numbers and names from the SIM card to the phone memory.

2.3.1. From SIM to phone memory

2.3.2. From phone to SIM memory.

2.4. Speed dial

A number stored in the phone book can be stored as a speed dial number.

2.5. Erase SIM

Erase the entire SIM card memory.

2.6. Erase phone

Erase the entire phone memory.

2.7. Memory status

Shows how many positions are occupied in the SIM card and phone memory. The table shows how many of the total number of positions are occupied, e.g. 100 (250).

3. Messages**3.1. Read**

Received text messages. Select whether to erase, forward, change or save the entire message or parts of it.

3.2. Write

Write a message using the keypad. Choose whether to save or send it.

3.3. Message sett

Enter the number (SMSC number) of the message centre to which messages are to be transferred as well as how long they are to be saved at the message centre. Contact your network operator for information on message settings. Normally, these settings should not be altered.

3.3.1. SMSC number

3.3.2. Validity time

3.3.3. Message type

4. Call options**4.1. Send my no.**

Displays or hides your phone number to/from the person you call. Contact your network operator regarding ex-directory numbers.

4.2. Call waiting

Be alerted during a phone call that there is another incoming call.





Menu structure – phone*

4.3. Auto answer

Automatically answers incoming calls.

4.4. Auto redial

Automatically calls a previously engaged number.

4.5. Voice mail number

Stores voice mail number.

4.6. Diversion

Choose when and what type of calls are to be diverted to a specified phone number.

4.6.1. All calls

This setting only applies during the call in progress

4.6.2. When engag.

4.6.3. Not answered

4.6.4. Not reachable

4.6.5. Fax calls

4.6.6. Data calls

4.6.7. Cancel all

5. Phone settings

5.1. Network

Choose a network automatically or manually. The selected network is shown in the display in the phone's basic mode.

5.1.1. Auto

5.1.2. Manual select

5.2. SIM security

Select if the PIN code should be on, off or if the phone should automatically give the PIN code.

5.2.1. On

5.2.2. Off

5.2.3. Auto

5.3. Edit codes

Change PIN or phone code. Write the codes down and keep them in a safe place.

5.3.1. PIN code

5.3.2. Phone code.

The factory-set phone code 1234 is used until you change to your own code.

5.4. Sounds

5.4.1. Volume.

Adjust the ring tone volume.

5.4.2. Ring signal.

There are seven different ring tones.

5.4.3. Mute radio. On/off

5.4.4. Msg. beep

5.5. IDIS

If the IDIS function is deactivated, incoming calls are not delayed, regardless of the driving situation.

5.5. Factory sett.

Reset the system's factory settings.



Bluetooth handsfree*

General

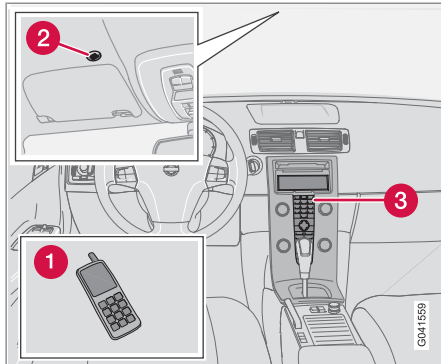

System overview.

- 1 Mobile phone
- 2 Microphone
- 3 Centre console

Bluetooth™

A mobile phone equipped with Bluetooth™ can be connected wirelessly to the audio system. The audio system then works handsfree, with the option to control a range of the mobile phone's functions remotely. The microphone is fitted in the roof console (2). The mobile phone can always be operated by its own keys irrespective of whether or not it is connected.

NOTE

Only a selection of mobile phones are fully compatible with the handsfree function. Volvo recommends that you seek assistance from an authorised Volvo dealer or www.volvocars.com for information on compatible phones.

Menus and controls

The menus are navigated using the control panel in the centre console (3), see page 245.

Remember

The menus are controlled from the centre console and the steering wheel keypad. For general information on menus, see page 250.

Activating/deactivating

A short press on **PHONE** activates the handsfree function. The text **PHONE** at the top of the display shows that it is in phone mode. The symbol  shows that the handsfree function is active.

One long press on **PHONE** deactivates the handsfree function and disconnects a connected phone.

Connect mobile phone

A mobile phone is connected in different ways depending on whether or not it has been con-

nected previously. To connect a mobile phone for the first time, follow the instructions below:

Alternative 1 - via the car's menu system

1. Make the mobile phone detectable/visible via Bluetooth™, see the mobile phone's manual or www.volvocars.com.
2. Activate the handsfree function with **PHONE**.
 - > Menu option **Add phone** appears on the display. If one or more mobile phones have already been registered then these are also shown.
3. Select **Add phone**.
 - > The audio system searches for mobile phones in the vicinity. The search takes approximately 30 seconds. The mobile phones detected are specified with their respective Bluetooth™ name in the display. The handsfree function's Bluetooth™ name is shown in the mobile phone as **My Car**.
4. Choose one of the mobile phones in the audio system display.
5. Enter the number series shown in the audio system display via the mobile phone keypad.



Bluetooth handsfree*

Alternative 2 - via the phone's menu system

1. Activate the handsfree function with **PHONE**. If there is a phone connected, disconnect the connected phone.
2. Search with the phone's Bluetooth™, see the mobile phone's manual.
3. Select **My Car** in the list of units detected in your mobile phone.
4. Enter the PIN code '1234' into the mobile phone when prompted for the PIN code.
5. Select to connect to **My Car** from the mobile phone.

The mobile phone is registered and connected automatically to the audio system while the text **Synchronising** is shown in the display. For more information on how mobile phones are registered, see page 255.

When the connection is established the symbol  is shown and the mobile phone's Bluetooth™ name is shown in the display. Now the mobile phone can be controlled from the audio system.

To call

1. Make sure that the text **PHONE** is shown at the top of the display and that the  symbol is visible.
2. Dial the number or use the phone book, see page 256.
3. Press **ENTER**.

The call is interrupted with **EXIT**.

Disconnecting the mobile phone

Automatic disconnection takes place if the mobile phone moves out of the audio system's range. For more information on connection, see page 255.

Manual disconnection takes place by deactivating the handsfree function with one long press on **PHONE**. The handsfree function is also deactivated when the engine is switched off or when a door is opened¹.

When the mobile phone has been disconnected an ongoing call can be continued with the mobile phone's built-in microphone and speaker.



NOTE

Some mobile phones require that the changeover from handsfree is confirmed from the phone's keypad.

Making and receiving calls

Incoming call

Calls are accepted with **ENTER** even if the audio system is in CD or FM mode for example. Refuse or end with **EXIT**.

Auto answer

The automatic answer function means that calls are accepted automatically. Activate/deactivate under **Phone menu** → **Phone settings** → **Call options** → **Automatic answer**.

In-call menu

Press **MENU** or **ENTER** during an ongoing call to access the following functions:

- **Microphone muted** - audio system microphone is muted.
- **Transfer call to mobile** - the call is transferred to the mobile phone.

¹ Applies to Keyless Drive.



Bluetooth handsfree*

i NOTE

With certain mobile phones the connection is terminated when the privacy function is used. This is normal. The handsfree function asks if you want to reconnect.

- **Phone book** – searching in the phone book.

i NOTE

A new call cannot be started during an ongoing call.

Audio settings**Call volume**

The call volume can be regulated when the handsfree function is in phone mode. Use the steering wheel keypad or **VOLUME**.

Audio system volume

Providing there is no ongoing call taking place, the audio system volume is controlled as usual with **VOLUME**. In order to control audio system volume during an ongoing call you have to switch to one of the audio sources.

The audio source can be automatically muted for incoming calls under **Phone menu** →

Phone settings → **Sounds and volume** → **Mute radio**.

Ring volume

Go to **Phone menu** → **Phone settings** → **Sounds and volume** → **Ring volume** and adjust with ▲ / ▼ on the navigation button.

Ring signals

The handsfree function has integrated ring signals that can be selected under **Phone menu** → **Phone settings** → **Sounds and volume** → **Ring signals...** → **Ring signal 1, 2, 3** etc.

i NOTE

The connected mobile phone's ring signal is not deactivated when one of the handsfree system's integrated signals is used.

In order to select the connected phone's ring signal², go to **Phone menu** → **Phone settings** → **Sounds and volume** → **Ring signals...** → **Use mobile phone signal**.

More on registering and connecting

A maximum of five mobile phones can be registered. Registration is performed once per phone. After registration the phone no longer needs to be visible/detectable. A maximum of one mobile phone can be connected at a time. Phones can be deregistered under **Bluetooth menu** → **Bluetooth** → **Remove phone**.

Automatic connection

When the handsfree function is active and the last mobile phone connected is in range it is connected automatically. When the audio system searches for the last phone connected its name is shown in the display. To change over to manual connection of another phone, press **EXIT**.

Manual connection

If you want to connect a mobile phone other than the last connected or change the connected mobile phone, proceed as follows:

1. Set the audio system in phone mode.
2. Press **PHONE** and select one of the phones in the list.

The connection can also be made via the menu system under **Bluetooth menu** → **Bluetooth** → **Connect phone** or **Change phone**.

² Not supported by all mobile phones.



Bluetooth handsfree*

Phonebook

All use of the phone book presupposes that the text **PHONE** is shown at the top of the display and that the symbol is visible.

The audio system stores a copy of the phone book from each registered mobile phone. The phone book is copied automatically to the audio system during each connection. Deactivate the function under **Phone settings** → **Synchronise phone book**. Searching for contacts is only performed in the connected mobile phone's phone book.

NOTE

If the mobile phone does not support copying of the phone book then **List is empty** is shown when copying is finished.

If the phone book contains a ringing caller's contact information then this is shown in the display.

Searching for contacts

The easiest way to search in the phone book is with long presses on the keys **2-9**. This starts a search in the phone book based on the key's first letter.

The phone book can also be reached with / on the navigation button or with / on

the steering wheel keypad. The search can also be performed from the phone book's Search menu under **Phonebook** → **Search**:

1. Enter the first few letters of the contact and press **ENTER**. Or simply press **ENTER**.
2. Scroll to a contact and press **ENTER** to call.

Voice recognition

The mobile phone's voice recognition function for dialling can be used by holding in **ENTER**.

Voice mail number

Voice mail number can be changed under **Phone settings** → **Call options** → **Voice mail number**. If there is no number stored then this menu can be reached with one long press on **1**. Press **1** for a long time to use the stored number.

Call lists

The call lists are copied to the handsfree function at each new connection and are then updated during the connection. Press **ENTER** to show the last dialled. Other call lists are available under **Call register....**

NOTE

Certain mobile phones show a list of the last dialled calls in reverse order.

Inputting text

Input text using the keypad in the centre console. Press once for the key's first character, twice for the second etc. Continue pressing for more characters, see the table on page 247.

A short press on **EXIT** deletes an input character. One long press on **EXIT** clears all input characters. / on the navigation button scrolls between the characters.

Menu structure - Bluetooth

1. **Missed calls**
2. **Received calls**
3. **Dialled calls**
4. **Phonebook**
 - 4.1. Search
 - 4.2. Copy from phone
5. **Bluetooth...**
 - 5.1. Change phone
 - 5.2. Connect phone
 - 5.3. Disconnect phone
 - 5.4. Connect from mobile phone



Bluetooth handsfree*

6. **Phone settings**
 - 6.1. Call options
 - 6.1.1. Auto reply
 - 6.1.2. Voice mail number
 - 6.2. Sounds and volume
 - 6.3. Synchronise phone book

Type designation.....	260
Dimensions and weights.....	263
Engine specifications.....	266
Engine oil.....	267
Fluids and lubricants.....	271
Fuel.....	274
Catalytic converter.....	278
Electrical system.....	279
Type approval.....	281

01 10

SPECIFICATIONS



11

11 Specifications

Type designation

11

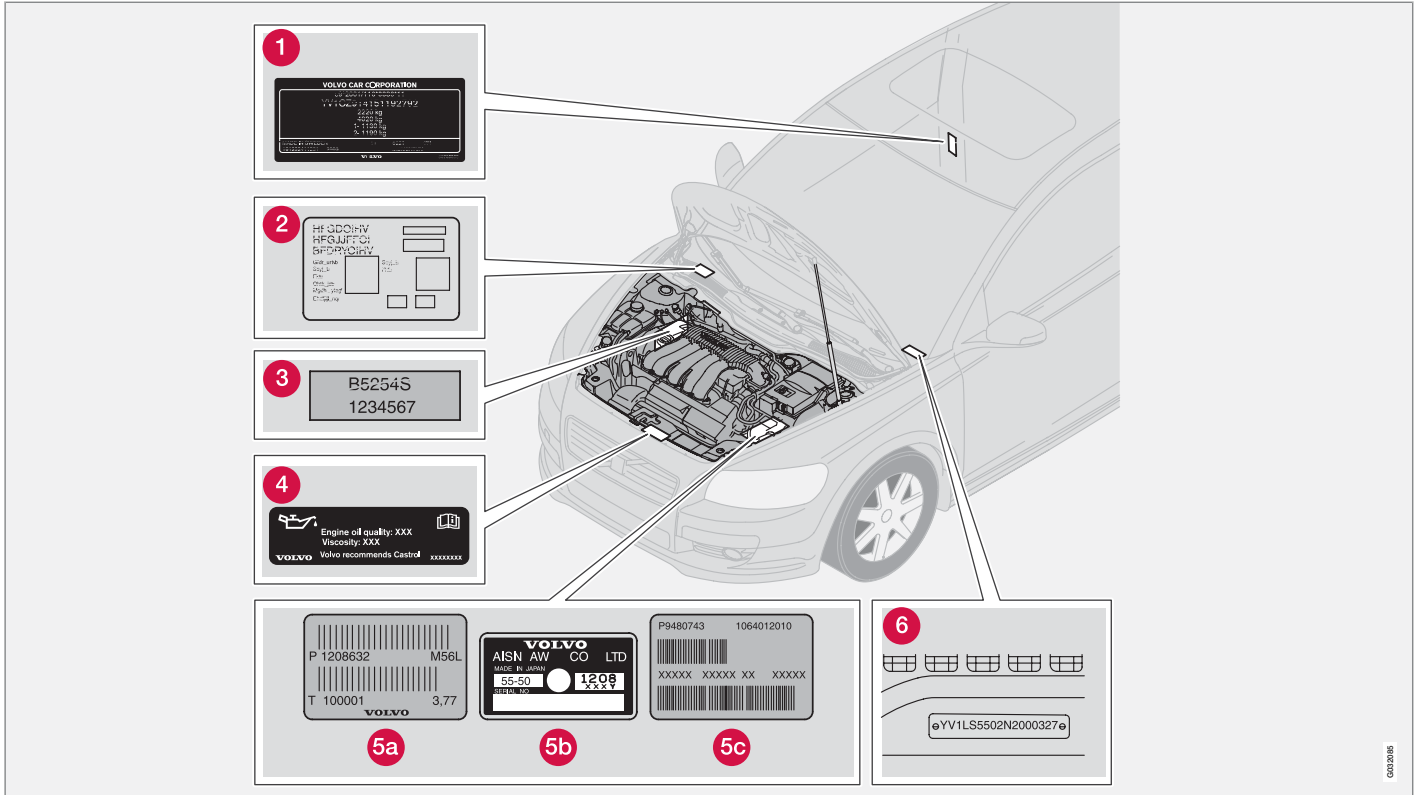

Type designation

Knowing the car's type designation, vehicle identification and engine numbers can facilitate all contact with a Volvo dealer regarding the car and when ordering spare parts and accessories.

- 1 Type designation, vehicle identification number, maximum permissible weights, codes for colour and upholstery and type approval number.
- 2 Label for parking heater.
- 3 Engine type designation, component and serial number.
- 4 Label for engine oil.
- 5 Gearbox type designation and serial number:
 - A manual gearbox
 - B, C automatic gearbox
- 6 VIN number (type and model year designation plus chassis number).

Further information on the car is presented in the registration document.

Type designation



NOTE

The labels shown in the owner's manual are not provided as exact reproductions of those in the car. The purpose is to show their approximate appearance and location in the car. The information that applies to your car in particular is available on the label in question in your car.

Dimensions and weights

Dimensions

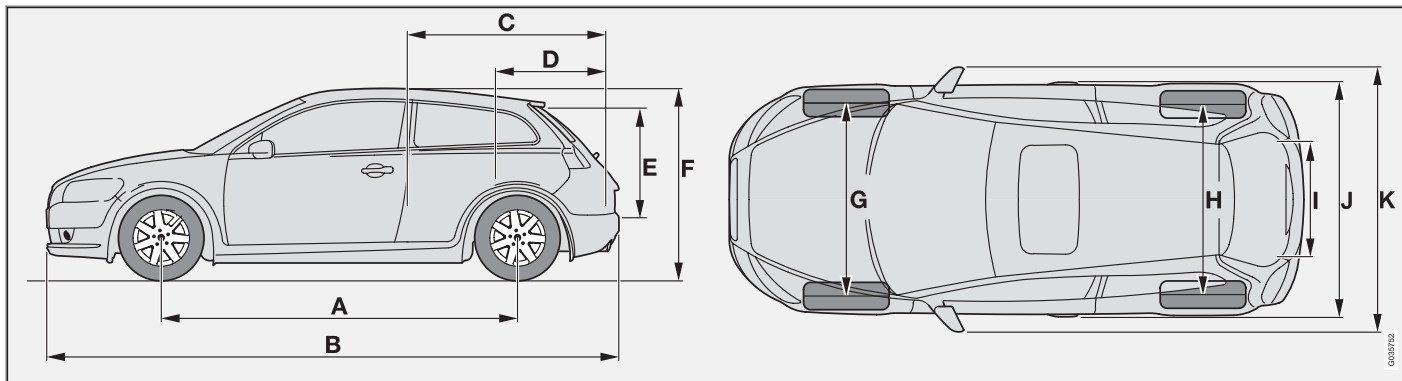

	Dimensions	mm
A	Wheelbase	2640
B	Length	4252
C	Load length, floor, folded seat	1486
D	Load length, floor	663
E	Load height	642
F	Height	1447
G	Front track	1535

	Dimensions	mm
H	Rear track	1531
I	Load width, floor	713
J	Width	1782
K	Width including door mirrors	2039

Weights

Kerb weight includes the driver, the fuel tank 90% full and all fluids.

The weight of passengers and accessories, and towball load (when a trailer is hitched, see table) influences the payload and is not included in the kerb weight.

Permitted maximum load = Gross vehicle weight - Kerb weight.

Dimensions and weights

NOTE

The documented kerb weight applies to cars in the standard version - i.e. a car without extra equipment or accessories. This means that for every accessory added the loading capacity of the car is reduced correspondingly by the weight of the accessory.

Examples of accessories that reduce loading capacity are the Kinetic/Momentum/Summum equipment levels, as well as other accessories such as Towbar, Load carriers, Space box, Audio system, Auxiliary lamps, GPS, Fuel-driven heater, Safety grille, Carpets, Cargo cover, Power seats, etc.

Weighing the car is a certain way of ascertaining the kerb weight of your own particular car.

WARNING

The car's driving characteristics change depending on how heavily it is loaded and how the load is distributed.

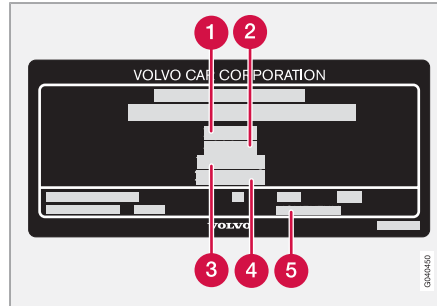

For decal location, see page 260.

- 1 Max. total weight
- 2 Max. train weight (car+trailer)
- 3 Max. front axle load
- 4 Max. rear axle load
- 5 Equipment level

Max. load: See registration document.

Max. roof load: 75 kg.

Towing capacity and towball load

Engine	Maximum weight, braked trailer (kg)	Maximum towball load (kg)
1.6	1200	50
1.6D	1300	75

Dimensions and weights

Engine	Maximum weight, braked trailer (kg)	Maximum towball load (kg)
1.8	1300	75
1.8F	1300	
2.0	1350	
others	1500	

Maximum weight, unbraked trailer (kg)	Maximum towball load (kg)
700	50

Engine specifications

Overview

Engine		Output (kW/rpm)	Output (hp/rpm)	Torque (Nm/rpm)	No. of cylinders	Bore (mm)	Stroke (mm)	Swept volume (litres)	Compression ratio
1.6	B4164S3	74/6000	100/6000	150/4000	4	79	81.4	1,596	11.0:1
1.8	B4184S11	92/6000	125/6000	165/4000	4	83	83.1	1,798	10.8:1
1.8F	B4184S8	92/6000	125/6000	165/4000	4	83	83.1	1,798	10.8:1
2.0	B4204S3	107/6000	145/6000	185/4500	4	87,5	83.1	1,999	10.8:1
2.4i	B5244S4	125/6000	170/6000	230/4400	5	83	90.0	2,435	10.3:1
T5	B5254T7	169/5000	230/5000	320/1500 – 5000	5	83	93.2	2.521	9.0:1
1.6D	D4164T	80/4000	109/4000	240/1750	4	75	88.3	1,560	18.3:1
2.0D	D4204T	100/4000	136/4000	320/2000	4	85	88.0	1,997	18.5:1
D5	D5244T8	132/4000	180/4000	350/1750 – 3250	5	81	93.2	2,401	17.3:1
D5	D5244T13	132/4000	180/4000	400/2000 – 2750	5	81	93.2	2,401	17.3:1
D5	D5244T9 ^A	120/4000	163/4000	340/1750 – 3000	5	81	93.2	2,401	17.3:1

^A Belgium

Engine specifications

Engine type designation, component and serial number can be read on the engine, see page 260.

Adverse driving conditions

Check the oil level more frequently for long journeys:

- towing a caravan or trailer
- in mountainous regions
- at high speeds
- in temperatures colder than $-30\text{ }^{\circ}\text{C}$ or hotter than $+40\text{ }^{\circ}\text{C}$.

This can produce abnormally high oil temperature or oil consumption.

Also check the oil level more often if the car is often driven short distances (less than 10 km) when temperatures are low (below $+5\text{ }^{\circ}\text{C}$).

Choose a fully synthetic engine oil for adverse driving conditions. It provides extra protection for the engine.

Volvo recommends Castrol oil products.

! IMPORTANT

In order to fulfil the requirements for the engine's service intervals all engines are filled with a specially adapted synthetic engine oil at the factory. The choice of oil has been made very carefully with regard to service life, starting characteristics, fuel consumption and environmental impact.

An approved engine oil must be used in order that the recommended service intervals can be applied. Only use a prescribed grade of oil (see the engine compartment decal) for both filling and oil change, otherwise you will risk affecting service life, starting characteristics, fuel consumption and environmental impact.

Volvo Car Corporation disclaims all warranty liability if engine oil of the prescribed grade and viscosity is not used.

Viscosity chart

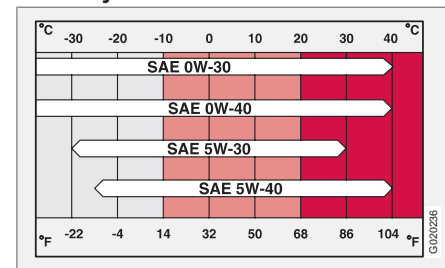

Engine oil

Oil decal

Engine oil grade

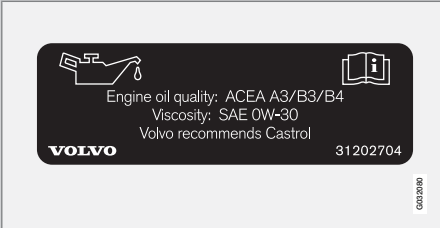
	Engine variant		Volume between MIN-MAX (litres)	Volume ^A (litres)
	 <p>Oil decal location in engine compartment, see page 202.</p> <p>Oil grade: ACEA A3/B3/B4</p> <p>Viscosity: SAE 0W-30</p> <p>When driving under adverse conditions, use ACEA A5/B5 SAE 0W-30.</p>	2.4i ^B	B5244S4	1,3
T5 ^B		B5254T7	1,3	5.8
1.6D		D4164T	1.0	3,8

^A Including filter change

^B Does not apply to Europe, for Europe see oil ACEA A5/B5

Engine oil

Engine oil grade

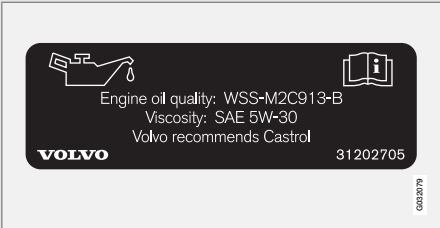
	Engine variant		Volume between MIN-MAX (litres)	Volume ^A (litres)
	 <p>Oil decal location in engine compartment, see page 202.</p> <p>Oil grade: WSS-M2C913-B</p> <p>Viscosity: SAE 5W-30</p> <p>When driving under adverse conditions, use ACEA A5/B5 SAE 0W-30.</p>	1.6	B4164S3	0.75
1.8		B4184S11	0.75	4.3
1.8F		B4184S8	0.75	4.3
2.0		B4204S3	0.75	4.3
2.0D		D4204T	1,8	5.0

^A Including filter change

Engine oil

Engine oil grade

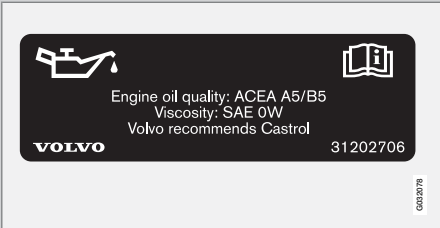
	Engine variant		Volume between MIN-MAX (litres)	Volume ^A (litres)
 <p>Oil decal location in engine compartment, see page 202.</p> <p>Oil grade: ACEA A5/B5</p> <p>Viscosity: SAE 0W-30</p>	2.4i	B5244S4 ^B	1,3	5.5
	T5	B5254T7 ^B	1,3	5.5
	D5	D5244T8	1.5	6.0
		D5244T9 (Only Belgium)		
		D5244T13		

^A Including filter change

^B Europe only, for other markets see oil ACEA A3/B3/B4

Fluids and lubricants

Overview

! IMPORTANT

The recommended transmission fluid must be used to prevent damage to the gearbox. Do not mix with any other transmission fluid. If the transmission is topped up with a different fluid, contact a workshop nearby for servicing. Volvo recommends that you contact an authorised Volvo workshop.

Gearbox oil

System		Volume (litres)	Prescribed transmission fluid
1.6 petrol	Manual 5-speed, IB5	2.1	BOT 130 M
1.8 petrol	Manual 5-speed, MTX75	1,8	BOT 350M3
1.8F Flexifuel	Manual 5-speed, MTX75	1,8	BOT 350M3
2.0 petrol	Manual 5-speed, MTX75	1,8	BOT 350M3
2.0 petrol	Automatic, MPS6	5.5	BOT 341
2.4i petrol	Manual 5-speed, MTX75	2.1	BOT 350M3
2.4i petrol	Automatic, AW55-51	7.7	JWS 3309
T5 petrol	Manual 6-speed, M66	1.9	BOT 350M3
T5 petrol	Automatic, AW55-51	7.7	JWS 3309
1.6D diesel	Manual 5-speed, MTX75	1,8	BOT 350M3

Fluids and lubricants

System		Volume (litres)	Prescribed transmission fluid
2.0D diesel	Manual 6-speed, MMT6	1.7	BOT 350M3
2.0D diesel	Automatic, MPS6	5.5	BOT 341
D5 diesel	Manual 6-speed, M66	1.9	BOT 350M3
D5 diesel	Automatic, AW55-51	7.7	JWS 3309

Fluids

Fluid	System	Volume (litres)	Recommended oil grade
Coolant	1.6 petrol	6.2	Coolant with corrosion inhibitor mixed with water ^A , see packaging. The thermostat starts opening at: petrol engine (1.6) 82 °C petrol engines 90 °C, diesel engines 82 °C diesel engine (1.6D) 83 °C
	1.8, 1.8F and 2.0 petrol	7.5	
	5-cyl. manual gearbox	9.5	
	5-cyl. automatic gearbox	10.0	
	1.6D diesel	7.2	
	2.0D diesel	9.5	
Refrigerant	Air conditioning	^B	R134a (HFC134a) Oil: PAG
Brake fluid	Brake system	0.6	DOT 4+
Power steering fluid	Power steering	0.8 – 0.9	WSS M2C204-A2 or equivalent product with same specifications.

Fluids and lubricants

Fluid	System	Volume (litres)	Recommended oil grade
Washer fluid	4-cyl. Petrol/Diesel	4.0	Use a washer antifreeze recommended by Volvo, mixed with water for temperatures below freezing.
	5-cyl. Petrol/Diesel	6.5	

^A Water quality must fulfil the standard STD 1285.1.

^B Refrigerant quantity varies depending on engine variant. Contact an authorised Volvo workshop for the correct information.

Fuel

Consumption, CO₂ emissions and tank volume

Engine		Gearbox	Emissions of carbon dioxide CO ₂ (g/km)	Consumption (litre/100 km)	Tank volume (litres)
1.6	B4164S3	Manual 5 speed (IB5)	167	7.0	approx. 53
1.8	B4184S11	Manual 5 speed (MTX75)	174	7.3	approx. 53
1.8F ^A	B4184S8	Manual 5 speed (MTX75)	174	7.3	approx. 53
2.0	B4204S3	Manual 5 speed (MTX75)	177	7.4	approx. 53
2.4i	B5244S4	Manual 5 speed (M56)	200	8.4	approx. 62
2.4i	B5244S4	Automatic gearbox (AW55-51)	214	9.0	approx. 62
T5	B5254T7	Manual 6 speed (M66)	203	8.7	approx. 62
T5	B5254T7	Automatic gearbox (AW55-51)	211	9.0	approx. 62
1.6D	D4164T	Manual 5 speed (MTX75)	119	4,5	approx. 52
2.0D	D4204T EURO4)	Manual 6 speed (MMT6)	151	5.7	approx. 52
2.0D	D4204T	Manual 5 speed (M56)	146	5.5	approx. 52
2.0D	D4204T	Automatic gearbox (MPS6)	156	5.9	approx. 52
D5	D5244T13	Manual 6 speed (M66)	164	6.2	approx. 60

Fuel

Engine		Gearbox	Emissions of carbon dioxide CO ₂ (g/km)	Consumption (litre/100 km)	Tank volume (litres)
D5	D5244T8	Automatic gearbox (AW55-51)	182	6.9	approx. 60
D5	D5244T9 (Only Belgium)	Automatic gearbox (AW55-51)	182	6.9	approx. 60

A Flexifuel can be driven on any 95 octane unleaded petrol, or bioethanol E85, as well as all possible mixtures of these two fuels. The car consumes 30-40% more E85 which has a lower energy content. The precise difference depends on driving style, ambient temperature and variations in fuel specification amongst other things.

Fuel consumption and emissions of carbon dioxide

Official fuel consumption figures are based on a standard driving cycle in accordance with EU Directive 80/1268/EEC comb. and 92/21/EEC.

Fuel consumption figures may change if the car is equipped with extra equipment that affects the car's weight. The manner in which the car is driven, and other non-technical factors can also affect fuel consumption.

Consumption is higher and power output lower for fuel with an octane rating of 91 RON.

NOTE

Extreme weather conditions, towing a trailer or driving at high altitudes in combination with fuel grade are factors that could affect the car's performance.

General information on fuel

WARNING

Always avoid inhaling fuel fumes and fuel splashing in the eyes.

If fuel gets into your eyes, take out contact lenses if worn and rinse your eyes with plenty of water for at least 15 minutes and seek medical attention.

Never swallow fuel. Fuels such as petrol, bioethanol and mixtures of the two, as well as diesel, are highly toxic and could cause permanent injury or be fatal if swallowed. Seek medical attention immediately if fuel has been swallowed.

IMPORTANT

Mixing different types of fuel or the use of fuel not recommended invalidates Volvo's guarantees, and any associated service agreement. This applies to all engines.
NOTE: It does not apply to cars with engines that are adapted to run on ethanol fuel (E85).

Petrol

Petrol must meet the EN 228 standard. Most engines can be run with octane ratings of 91, 95 and 98 RON.

- 91 RON must not be used for 4-cylinder engines and should only be used in exceptional cases with other engines.
- 95 RON can be used for normal driving.
- 98 RON is recommended for optimum performance and minimum fuel consumption.

Fuel

When driving in temperatures above +38 °C, fuel with the highest possible octane rating is recommended for optimum performance and fuel economy.

! IMPORTANT

- Always refuel with unleaded petrol so as not to damage the catalytic converter.
- Do not use additives not recommended by Volvo.

Bioethanol E85

Do not modify the fuel system or its components, and do not replace components with parts that are not specially designed for use with bioethanol.

! WARNING

Methanol must not be used. A decal on the inside of the fuel filler flap shows the correct alternative fuel.

The use of components not designed for bioethanol engines could cause fire, injury or engine damage.

Reserve fuel can

The reserve fuel can should be filled with petrol, see page 137.

! WARNING

Ethanol is sensitive to sparks, and explosive gases could form in the reserve fuel can if it is refuelled with ethanol.

Diesel

Diesel must fulfil the EN 590 or JIS K2204 standards.

Diesel engines are sensitive to contaminants, such as excessively high volumes of sulphur particles for example. Only use diesel fuel from well-known producers. Never use diesel of dubious quality.

At low temperatures (-40 °C to -6 °C), a paraffin precipitate may form in the diesel fuel, which can lead to ignition problems. Special diesel fuel designed for low temperatures around freezing point is available from the major oil companies. This fuel is less viscous at low temperatures and reduces the risk of paraffin precipitate.

The risk of condensation in the fuel tank is reduced if the tank is kept well filled. When

refuelling, check that the area around the fuel filler pipe is clean. Avoid spilling fuel onto the paintwork. Wash off any spillage with detergent and water.

! IMPORTANT

Only ever use fuel that fulfils the European diesel standard.

! IMPORTANT

Diesel type fuels which must not be used: special additives, Marine Diesel Fuel, fuel oil, RME¹ (Rape Methyl Ester) and vegetable oil. These fuels do not fulfil the requirements in accordance with Volvo recommendations and generate increased wear and engine damage that is not covered by the Volvo warranty.

! IMPORTANT

The sulphur content must be a maximum of 50 ppm.

Empty tank

After stalling due to fuel shortage the fuel system needs a short time to perform a check. Proceed as follows before the engine is started:

¹ Diesel fuel may contain a certain amount of RME, but further amounts must not be added.

Fuel

1. Fill at least 5 litres of diesel in the fuel tank.
2. Insert the remote control key in the ignition switch and turn to key position **II** (see page 135).
3. Wait for about 1 minute.
4. To start the engine: Depress the brake and/or clutch pedal, and turn the remote control key to start position **III**.

Draining condensation from the fuel filter

The fuel filter separates condensation from the fuel. Condensation can disrupt engine operation.

The fuel filter must be drained at the intervals specified in the Service and Warranty Booklet or if you suspect that the car has been filled with contaminated fuel.

! IMPORTANT

Certain special additives remove the water separation in the fuel filter.

Diesel particle filter (DPF)

Diesel cars may be equipped with a particle filter, which results in more efficient emission control. The particles in the exhaust gases are collected in the filter during normal driving. So-called "regeneration" is started in order to burn away the particles and empty the filter. This

requires the engine to have reached normal operating temperature.

Regeneration of the filter takes place automatically at an interval of approximately 300–900 km depending on driving conditions. Regeneration normally takes between 10 - 20 minutes. It may take a little longer at a low average speed. Fuel consumption may increase slightly during regeneration.

The rear window heating may be activated automatically to increase the load on the engine during regeneration without warning.

Regeneration in cold weather

If the car is frequently driven short distances in cold weather then the engine does not reach normal operating temperature. This means that regeneration of the diesel particle filter does not take place and the filter is not emptied.

When the filter has become approximately 80% full of particles, the yellow information symbol on the instrument panel illuminates, and the message **SOOT FILTER FULL - SEE MANUAL** is shown on the instrument panel display.

Start regeneration of the filter by driving the car until the engine reaches normal operating temperature, preferably on a main road or motorway. The car should then be driven for approximately 20 minutes more.

When regeneration is complete the message is cleared automatically.

! IMPORTANT

If the filter fills up it may be incapable of functioning. Then it can be difficult to start the engine and there is a risk that the filter will have to be replaced.

Use the parking heater* in cold weather so that the engine reaches normal operating temperature more quickly.

* Option/accessory, for more information, see Introduction.

Catalytic converter

General

The purpose of the catalytic converter is to purify exhaust gases. It is located in the flow of exhaust gases close to the engine so that it quickly reaches operating temperature. The catalytic converter consists of a monolith (ceramic or metal) with channels. The channel walls are lined with a thin layer of platinum, rhodium and palladium. These metals act as catalysts, i.e. they participate in and accelerate a chemical reaction without being used up themselves.

Lambda-sond™ oxygen sensor

The Lambda-sond is part of a control system intended to reduce emissions and improve fuel economy.

An oxygen sensor monitors the oxygen content of the exhaust gases leaving the engine. This value is fed into an electronic system that continuously controls the injectors. The ratio of fuel to air directed to the engine is continuously adjusted. Together with the three-way catalytic converter, these adjustments create optimal conditions for efficient combustion of the harmful emissions (hydrocarbons, carbon monoxide and nitrous oxides).

Electrical system

General

12 V system with a voltage-regulated alternator. Single pole system in which the chassis and engine block are used as conductors.

If the battery is changed, replace it with a battery of the same cold start capacity and reserve capacity as the original (see the decal on the battery).

Battery

Engine	Voltage, V	Cold start capacity (CCA, Cold Cranking Amperes), A	Reserve capacity, minutes	Capacity, Ah
4 and 5-cyl. petrol	12	590	100	60
		600 ^A	120	70
4 and 5-cyl. diesel	12	700 ^B	135	80

^A Cars equipped with High Performance audio system.

^B Cars equipped with diesel, keyless drive, Premium Sound audio system, fuel-driven heater or RTI.



Bulbs

Lighting	Output (W)	Type
Dipped beam	55	H7
Main beam	55	H9
Brake lights, reversing lamps, rear fog lamp	21	P21W
Direction indicators, rear/front	21	PY21W
Rear position/parking lamps, rear side marker lamps	4	P21/5W

Electrical system

Lighting	Output (W)	Type
Courtesy lighting, cargo area lighting, number plate lighting	5	C5W
Vanity mirror*	1.2	Tubular lamp
Front position/parking lamps, front side marker lamps	5	W5W
Fog lamps	55	H8
Glovebox lighting	3	Tubular lamp

Remote control key system

Country and region	
A, B, CY, CZ, D, DK, E, EST, F, FIN, GB, GR, H, I, IRL, L, LT, LV, M, NL, P, PL, S, SK, SLO	 Delphi hereby certifies that this remote control key system conforms to the essential characteristic requirements and other relevant regulations of directive 1999/5/EC.
IS, LI, N, CH	
HR	
ROK	Delphi 2003-07-15, Germany R-LPD1-03-0151
BR	
TW	 ETC093LPD0155

Certification of the Keyless Drive system

Siemens VDO Automotive A.G. hereby certifies that this equipment type 5WK4 8952, 5WK48956, 5WK48812 conforms to the essential characteristic requirements and other relevant regulations of Directive 1999/5/EC.

A**A/C**

- electronic climate control..... 89
- manual climate control..... 84, 85

ABS fault..... 47, 146

Adaptation..... 138

Additional heater (Diesel)..... 94

Adjusting headlamp pattern..... 168

- Dual Xenon headlamps..... 168
- halogen headlamp..... 168

AF – automatic frequency update..... 237

Airbag..... 20

- activating/deactivating, PACOS..... 23
- deactivating/activating..... 23
- driver's and front passenger side..... 21

Air conditioning..... 84

- ECC..... 87
- general..... 82

Air distribution..... 90

- ECC..... 88

Air distribution, A/C..... 85

Air quality system, ECC..... 88

Air vents..... 83

Alarm..... 127

- alarm indicator..... 127
- arming..... 127
- automatic alarm activation..... 128
- deactivating a triggered alarm..... 128
- disarming..... 127
- RDS traffic warning..... 235
- reduced alarm level..... 128
- testing the alarm system..... 129

Antenna location, Keyless drive..... 122

Approach light, duration..... 70

- setting..... 75

Audio, see also Sound..... 230

Audio volume

- phone..... 247, 255
- phone/media player..... 255
- ring signal, phone..... 255

Auto

- climate control settings..... 87

AUTO

- storing stations..... 234

Auto climate..... 87

Automatic car washes..... 190

Automatic gearbox

- manual gear positions (Geartronic)..... 142
- towing and recovery..... 156
- trailer..... 159

Automatic locking..... 125

Automatic relocking..... 124

Autostart..... 135

Auto volume control..... 232

Auxiliary heater..... 94

Average fuel consumption..... 56

B

Backrest rear seat, lowering..... 110

Bass speaker..... 231

Battery..... 209, 279

- changing the battery in the remote control key..... 123
- maintenance..... 199, 209
- overload..... 133
- specifications..... 279
- start assistance..... 158
- symbols on the battery..... 209

Bioethanol E85..... 274

Blind spot (BLIS)..... 152

Blind Spot Information System, BLIS	71, 152
Bluetooth	
handsfree.....	253
mute microphone.....	254
transfer call to mobile.....	254
Boarding	
rear seat.....	98
Bonnet, opening.....	200
Brake and clutch fluid.....	206
Brake light.....	54
Brakes	
anti-lock braking system, ABS.....	146
brake light.....	54
emergency brake assistance, EBA.....	147
emergency brake lights.....	54
handbrake.....	65
Brake system.....	146
Bulb holder	
removal.....	214
Bulbs	
changing.....	211
Bulbs, see Lighting.....	211, 279

[

Calls	
functions during a call.....	246, 249
incoming.....	254
operation.....	246, 254
volume in phone.....	247
Car care.....	190
Car care, leather upholstery.....	192
Cargo area.....	111
cargo cover.....	111
lighting.....	103
loading.....	167
safety net.....	113
Cargo cover.....	111
Car settings.....	75
Car upholstery.....	192
Car wash.....	190
Catalytic converter.....	278
recovery.....	156
CD discs	
storage compartment.....	108
CD functions.....	239
Checking and topping up the coolant.....	205

Checks	
fluids and oils.....	203
Children.....	32
child seats and side airbags.....	25
location in the car.....	32
location in the car, table.....	33
safety.....	32
Child seat.....	32
Child seats.....	32
ISOFIX fixture system for child seats... ..	35
upper mounting points for child seats..	36
Cigarette lighter socket	
front seat.....	52
Cleaning	
automatic car washes.....	190
car wash.....	190
rims.....	190
seatbelts.....	192
upholstery.....	192
Climate control	
general.....	82
personal preferences.....	74
Climate control settings	
auto.....	87
Clock, adjustment.....	74
Clutch fluid, checking & topping up.....	206

Coat hanger.....	107	Diesel: engine preheater.....	47	During a call, functions.....	249
Cold start.....	144	Diesel particle filter.....	277		
automatic gearbox.....	144	Dipstick, electronic.....	203	E	
Collision		Direction indicators.....	55	<hr/>	
crash mode.....	31	Disc text.....	240	ECC, electronic climate control.....	83
inflatable curtain, IC.....	27	Disengaging the gear selector inhibitor...	144	Economical driving.....	132
Colour code, paint.....	193	Display, messages.....	50	ECO pressure.....	176
Combined instrument panel.....	45	Display lighting.....	54	table.....	176
Compass.....	68	Dolby Surround Pro Logic II.....	228, 232	Electrical socket	
calibration.....	68	Door mirrors.....	70	centre console.....	52
setting the zone.....	68	Driver's door control panel.....	44, 66	rear seat.....	52
Condensation in headlamps.....	190	Driving		Electrical system.....	279
Coolant.....	205	cooling system.....	132	Emergency calls.....	244
Cooling system.....	132	economical.....	132	Emergency equipment	
Crash, see Collision.....	31	in water.....	132	warning triangle.....	179
Cruise control.....	61	slippery driving conditions.....	132	Emergency puncture repair.....	183
		with trailer.....	159	Emission control	
		Driving in water.....	132	fault indicator.....	47
D		Driving with a trailer		Engine block heater.....	137
<hr/>		towball load.....	263	fuel-driven.....	91
Deadlocks.....	125	towing capacity.....	263	Engine compartment.....	200
deactivation.....	125	DSTC, see also Stability control system..	148	coolant.....	205
temporary deactivation.....	125	DSTC, see also Stability system		power steering fluid.....	206
Defroster.....	85	symbol.....	47		
Diesel.....	276				

Engine oil.....	203, 267
adverse driving conditions.....	267
capacities.....	267
filter.....	202
oil grade.....	267
oil pressure.....	48
Engine specifications.....	266
Entry, keyless.....	75
Environmental labelling, FSC, owner's manual.....	13
EON - Enhanced Other Networks.....	237
Equalizer.....	232
Error messages in BLIS.....	154
Expectant mothers, seatbelt.....	17
External dimensions.....	263

F

Fan	
A/C.....	84
ECC.....	87
Fast-wind.....	240
First aid equipment.....	180

Flexifuel.....	137
adaptation.....	138
Floor hatch.....	112
Floor mats.....	101
Fluids, capacities.....	271
Fluids and oils.....	202, 271
Fluids and oils, checks, engine compart- ment.....	202
Fluids and oils general.....	202
Fog lamps	
rear.....	54
Fog lamps, on/off.....	54
Frequency update, automatic.....	237
Front seats, heated.....	85
FSC, environmental labelling.....	13
Fuel	
CO ₂ emissions.....	274
consumption.....	274
fuel consumption, display.....	56
fuel economy.....	176
level indicator.....	47
parking heater.....	91
refuelling.....	134
Fuses.....	218
box in the engine compartment.....	219

changing.....	218
general.....	218
relay/fuse box in the passenger com- partment.....	222

G

Gearbox	
manual.....	140
Gear selector assistance (GSI - Gear shift indicator).....	140
Gear selector inhibitor.....	143
Geartronic.....	142
General information on fuel.....	274
Glovebox.....	107
locking.....	118
Gross vehicle weight.....	263
GSI - Gear shift indicator.....	140

H

Handbrake.....	65
Hazard warning flashers.....	64
Headlamps.....	53

Heating	
front seats.....	85, 89
rearview and door mirrors.....	85, 89
rear window.....	85, 89
High-pressure headlamp washing.....	58
HomeLink® EU.....	76
Home safe lighting.....	55, 70
setting.....	75

I

IDIS – Intelligent Driver Information System.....	244
Ignition keys.....	136
IMEI number.....	249
Immobiliser.....	116, 136
Inflatable Curtain.....	27
Information display.....	50
Infotainment system	
menus.....	228
Instrument lighting.....	54
Instrument overview	
left-hand drive.....	40
right-hand drive.....	42

Interior lighting, see Lighting.....	103
Interior rearview mirror.....	68
automatic dimming.....	68
Intermittent wiping.....	58
iPod®, connection.....	230
ISOFIX fixture system for child seats.....	35

J

Jack.....	179
-----------	-----

K

Kerb weight.....	263
Key	
keyless lock and ignition system.....	120
remote control key.....	116
Key blade.....	117, 121
active locks.....	119
Keyless drive.....	120, 139, 281
starting the car.....	139
Keyless entry.....	75
Keyless start (keyless drive).....	120

Keypad in the steering wheel.....	61, 63, 245
Key positions.....	135
Kick-down	
automatic gearbox.....	142

L

Lambda-sond.....	278
Leather upholstery, washing instructions	192
Lighting	
approach light, duration.....	70
automatic lighting.....	104
automatic lighting, dipped beam.....	53
bulbs, specifications.....	279
cargo area.....	103
dipped beam.....	53
display lighting.....	54
front fog lamps.....	54
headlamp levelling.....	53
home safe lighting.....	55, 70
in passenger compartment.....	103
lighting panel, passenger compartment.....	53
main/dipped beam.....	53, 55
position/parking lamps.....	53

- reading lamps..... 103
 - rear fog lamp..... 54
 - Lighting, bulb replacement..... 211
 - cargo area..... 216
 - courtesy lighting..... 215
 - dipped beam..... 212
 - direction indicators..... 213
 - fog lamp..... 214
 - front..... 211
 - main beam..... 212
 - number plate lighting..... 215
 - parking lamps..... 213
 - passenger compartment lighting in
 - cargo area..... 216
 - position lamps..... 213
 - rear lamp..... 214
 - reflector..... 215
 - side marker lamps..... 213
 - vanity mirror..... 216
 - Loading
 - general..... 167
 - load capacity..... 167
 - load retaining eyelets..... 113
 - Load retaining eyelets..... 113
 - Locking..... 121
 - unlocking..... 124
 - Locking/unlocking..... 124
 - inside..... 124
 - outside..... 124
 - Locks
 - locking..... 124
 - Lubricants..... 271
 - Lubricants, capacities..... 271
- M**
-
- Main/dipped beam, see Lightning..... 53
 - Main beam
 - flashing..... 55
 - Main beam "flash"..... 55
 - Maintenance..... 199
 - rustproofing..... 194
 - self-maintenance..... 199
 - Making calls..... 246, 254
 - Manual gearbox..... 140
 - GSI - Gear shift indicator..... 140
 - towing and recovery..... 156
 - Manual gear positions (Geartronic)..... 142
 - Memory function in seats..... 102
 - Menus
 - audio system..... 228
 - Menu structure..... 74
 - media player..... 242
 - phone, menu options..... 251
 - phone, overview..... 250
 - Messages in BLIS..... 154
 - Messages in the information display..... 50
 - Meters in the combined instrument panel
 - fuel gauge..... 45
 - outside temperature gauge..... 45
 - speedometer..... 45
 - tachometer..... 45
 - trip meter..... 45
 - Misting
 - attending to the windows..... 82
 - condensation in headlamps..... 190
 - rear window..... 85
 - removing with defroster function.... 85, 88
 - timer function..... 85, 88
 - Mobile phone
 - connect..... 255
 - handsfree..... 253
 - register phone..... 253

N

 News..... 236
O

 Oil, see also Engine oil..... 203, 267

One-key dial..... 248

Owner's manual, environmental labelling.. 13

Oxyhydrogen gas..... 158

P

 PACOS..... 23

PACOS, switch..... 23

Paintwork

colour code..... 193

damage and touch-up..... 193

Parking assistance..... 150

parking assistance sensors..... 151

Parking brake..... 48, 65

Parking heater

battery and fuel..... 91

general..... 91

parking on a hill..... 91

symbols and display messages..... 92

time setting..... 93

Particle filter..... 277

Passenger compartment filter..... 82

Passenger compartment heater

fuel-driven..... 91

Personal preferences..... 74

approach light, duration..... 75

auto blower adjust..... 74

automatic locking..... 75

doors unlock..... 75

home safe lighting..... 75

keyless entry..... 75

lock confirm. light..... 75

recirculation timer..... 74

unlock confirm. light..... 75

Petrol grade..... 275

Phone

calling from the phone book..... 248

connect..... 255

controls..... 245

entering text..... 247

handsfree..... 253

incoming calls..... 254

making calls..... 254

on/off..... 246

one-key dial..... 248

phone book..... 256

phone book, shortcut..... 256

receiving a call..... 254

register phone..... 253

standby, standby mode..... 246

traffic safety..... 245

Phone book

handling numbers..... 247

Phone system..... 244

Pinch protection, sunroof..... 73

Polishing..... 191

Power seat..... 101

 Power steering fluid, checking and topping
up..... 206

Power sunroof..... 72

Power windows..... 66

passenger seat..... 67

Programme type..... 237

PTY – Programme type..... 236

Puncture, see Tyres..... 179, 181

Putting calls on hold..... 246

R

-
- Radio
 - EON..... 237
 - frequency update..... 237
 - news..... 236
 - programme types..... 235
 - radio settings..... 234
 - radio stations..... 234
 - REG..... 237
 - Radio text..... 237
 - Rain sensor..... 59
 - Random, CD and audio files..... 240
 - RDS functions..... 235
 - resetting..... 238
 - Reading lamps, see Lighting..... 103
 - Rear seat
 - boarding..... 98
 - Rearview and door mirrors
 - automatic retracting/extending..... 70, 75
 - compass..... 68
 - door..... 70
 - electrically retractable..... 70
 - interior..... 68
 - Recirculation
 - A/C..... 84
 - ECC..... 88
 - Reduced guard
 - settings..... 75
 - Refrigerant..... 82
 - Refuelling
 - fuel cap..... 134
 - fuel filler flap, electrical opening..... 134
 - refuelling..... 134
 - Refusing a call..... 246
 - REG - Regional radio programmes..... 237
 - Relay/fuse box: see Fuses..... 218
 - Remote control..... 116
 - programmable..... 76
 - replacing the battery..... 123
 - Remote control key..... 136
 - battery replacement..... 123
 - detachable key blade..... 117
 - functions..... 116
 - Remote control key system, type approval..... 281
 - Resetting the door mirrors..... 70
 - Reverse gear inhibitor
 - five-speed..... 140
 - six-speed, petrol..... 140
 - Rims
 - cleaning..... 190
 - Rustproofing..... 194
-
- S**
-
- Safety
 - safety systems, table..... 30
 - Safety net..... 113
 - Scan
 - CD and audio files..... 240
 - radio stations..... 235
 - Seatbelt
 - pregnancy..... 17
 - seatbelt guide..... 18
 - seatbelt tensioner..... 18
 - Seatbelt reminder..... 17
 - Seatbelts..... 16
 - Seats
 - lowering the rear backrest..... 110
 - manual setting..... 98
 - power seat..... 101

- Service programme..... 198
- Side airbags..... 25
- Side airbag SIPS..... 25
- SIM card..... 244
- SIPS bags..... 25
- SMS..... 249
 read..... 249
 write..... 249
- Soot filter..... 50, 277
- Soot filter full..... 277
- Sound
 audio settings..... 230, 231
 audio source..... 230
 volume..... 230
- Spare wheel..... 179
 temporary spare..... 174, 179
- Spin control..... 148
- SRS Airbag..... 20
- SRS system..... 20
 general..... 20
- Stability and traction control system..... 148
- Stains..... 192
- Standby, phone..... 246
- Start assistance..... 158
- Starting the engine..... 135
 keyless drive..... 120, 139
- Steering lock..... 135
- Steering wheel
 cruise control..... 61
 keypad..... 61, 63, 245
 steering wheel adjustment..... 64
- Stone chips and scratches..... 193
- Storage compartment..... 106
 CD discs..... 108
- Storage spaces in the passenger compartment..... 106
- Storing stations, manual and automatic.. 234
- Subwoofer..... 231
- Sunroof..... 72
 opening and closing..... 72, 73
 pinch protection..... 73
 sunscreen..... 73
 ventilation position..... 72
- Sunscreen, sunroof..... 73
- Surround..... 228, 232
- Symbols..... 149
 indicator symbols..... 47, 48
 warning symbols..... 46
- Symbols and display messages
 parking heater..... 92
- ## T
-
- Tailgate
 driving with open tailgate..... 132
 locking/unlocking..... 116, 124
- Tank volume..... 274
- Technical data, engine..... 266
- Temperature
 actual temperature..... 83
 passenger compartment, electronic climate control..... 89
 passenger compartment, manual climate control..... 86
- Testing the alarm system..... 129
- Timer
 A/C..... 85
 ECC..... 88
- Tools..... 179
- Total airing function..... 125
- Towbar, see Towing equipment..... 161
- Towing..... 156
 towing eye..... 157

Towing capacity.....	263
Towing equipment.....	161
installation.....	163
removing.....	165
specifications.....	162
Towing eye.....	157
TP – Traffic information.....	236
Traffic information.....	236
Trailer.....	159
cable.....	161
Trip computer.....	56
Tuning Radio.....	234
Type approval, remote control key system.....	281
Type designation.....	260
Tyres	
direction of rotation.....	175
driving characteristics.....	172
general.....	172
maintenance.....	172
pressure.....	176, 177
puncture repair.....	183
specifications.....	172
speed ratings.....	172
tread wear indicators.....	173
winter tyres.....	175

U

Unlocking.....	121, 124
settings.....	75
USB, connection.....	230

V

Ventilation.....	83
Vibration damper.....	161
Volume	
audio system.....	230
auto volume control.....	232
media player.....	230

W

Warning lamp	
stability and traction control system. .	148
Warning symbol, AIRBAG system.....	19
Warning triangle.....	179
Washer fluid, filling.....	204

Washers

headlamps.....	58
rear window.....	59
washer fluid, filling.....	204
windscreen.....	58

Water and dirt-repellent coating..... 71

Water-repellent surface, cleaning..... 191

Waxing..... 191

Weights

 kerb weight..... 263

Wheels

changing.....	181
installation.....	182
removal.....	181
rims.....	174
snow chains.....	173
spare wheel.....	179

Whiplash injury..... 28

WHIPS

child seat/booster cushion.....	28
whiplash injury.....	28

Windscreen wipers..... 58

 rain sensor..... 59

Winter tyres..... 175

Wiper

 rear window..... 59

Wiper blades..... 207
 cleaning..... 207
 replacing, rear window..... 207
 replacing, windscreen..... 207

Volvo. for life

VOLVO

Volvo Car Corporation TP 10898 (English), AT 0920, Printed in Sweden, Göteborg 2009, Copyright © 2000-2009 Volvo Car Corporation