

Image Cover Sheet

CLASSIFICATION

UNCLASSIFIED

SYSTEM NUMBER

151678



TITLE

CASE_ATT1: AN ALGORITHM-LEVEL TESTBED FOR MULTI-SENSOR DATA FUSION

System Number:

Patron Number:

Requester:

Notes:

DSIS Use only:

Deliver to:



UNCLASSIFIED

DEFENCE RESEARCH ESTABLISHMENT
CENTRE DE RECHERCHES POUR LA DÉFENSE
VALCARTIER, QUÉBEC

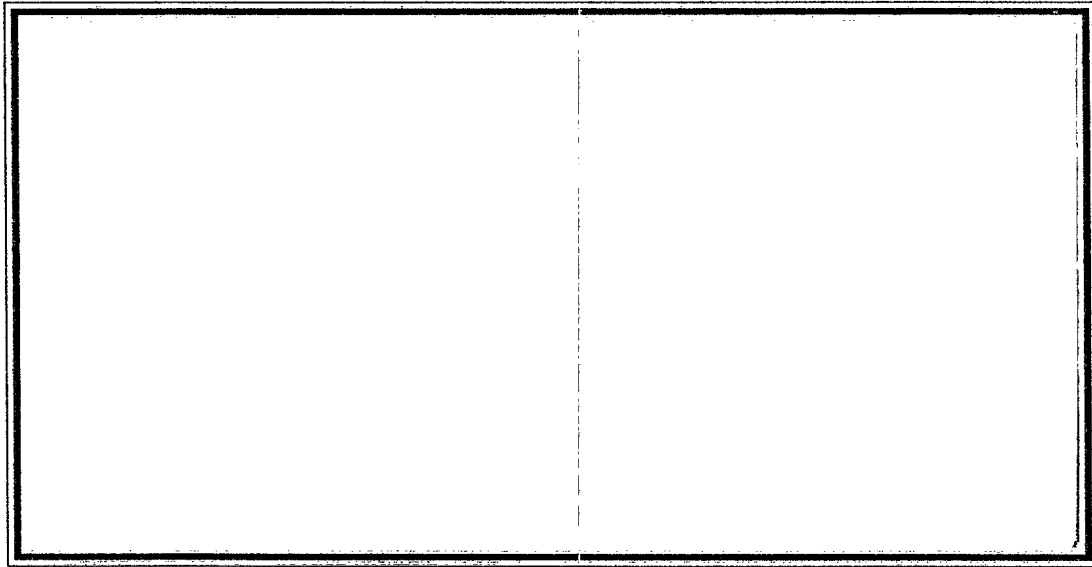

RESEARCH AND DEVELOPMENT BRANCH
DEPARTMENT OF NATIONAL DEFENCE
CANADA
BUREAU - RECHERCHE ET DÉVELOPPEMENT
MINISTÈRE DE LA DÉFENSE NATIONALE

UNCLASSIFIED

DEFENCE RESEARCH ESTABLISHMENT
CENTRE DE RECHERCHES POUR LA DÉFENSE
VALCARTIER, QUÉBEC

DREV - R - 9411

CASE_ATT1: AN ALGORITHM-LEVEL TESTBED
FOR MULTI-SENSOR DATA FUSION

by

J. Roy, É. Bossé and D. Dion

May / mai 1995

Approved by / approuvé par

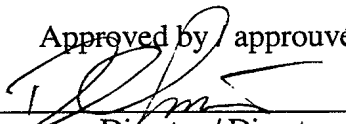

Director / Directeur

20/4/95
Date

SANS CLASSIFICATION

UNCLASSIFIED

i

ABSTRACT

A key element in the anticipated information management problem on a naval platform is the ability to combine or fuse data, not only as a volume-reducing strategy, but also as a means to exploit the unique combinations of data that may be available. In this regard, the Command and Control Division at DREV is involved in multiple R&D activities in the field of local area Multi-Sensor Data Fusion (MSDF) for naval command and control afloat. Many different approaches to MSDF have been investigated and developed recently in response to the ever-increasing importance of the subject. However, at this stage of development, no standard approach is generally accepted for all applications. A wide variety of techniques have been proposed for many diverse applications, and the system designer must choose the techniques that are best suited to a specific problem. One of the best tools to help the designer with such a choice is a computer simulation for proof-of-concept purposes. This document presents an overview of the CASE_ATTI (Concept Analysis and Simulation Environment for Automatic Target Tracking and Identification) algorithm-level simulation testbed that has been developed by DREV to support the theoretical work. CASE_ATTI provides the highly modular, structured and flexible hardware/software environment necessary to study and compare various advanced MSDF concepts and schemes in order to demonstrate their applicability, feasibility and performance. The document also discusses the use of CASE_ATTI to support an ongoing MSDF performance evaluation study in the context of the Canadian Patrol Frigate.

RÉSUMÉ

Un élément fondamental du problème anticipé de la gestion de l'information sur une plate-forme navale est la capacité de combiner ou de fusionner les données, non seulement comme stratégie de réduction du volume d'information mais aussi comme moyen d'exploiter les combinaisons uniques de données qui peuvent être disponibles. À cet égard, la Division du commandement et contrôle du Centre de recherches pour la défense, Valcartier (CRDV) participe à plusieurs activités de R&D dans le domaine de la fusion locale de données multi-capteurs pour le commandement et contrôle naval au large. En réponse à l'importance croissante de la fusion de données, on a récemment étudié et développé maintes façons d'aborder cette question. Cependant, à ce stade-ci du développement, aucune approche standard n'est généralement acceptée pour traiter toutes les applications. C'est pourquoi on a proposé une variété de techniques pour différentes applications. Le concepteur de systèmes doit choisir les techniques les plus appropriées à un problème donné. Un des meilleurs outils pour aider le concepteur dans ce choix est une simulation sur ordinateur pour démontrer les concepts. Ce document présente une vue d'ensemble du banc d'essai d'algorithmes EACS_PAC (environnement d'analyse de concepts et de simulation pour la poursuite et l'identification automatique de cibles) qui a été développé au CRDV pour appuyer les études théoriques. EACS_PAC procure l'environnement matériel/logiciel très modulaire, structuré et flexible nécessaire pour étudier et comparer différents concepts et plans avancés de fusion de données de capteurs dans le but de démontrer leur applicabilité, leur faisabilité et leur performance. Nous discutons également de l'utilisation d'EACS_PAC pour appuyer une étude en cours portant sur l'évaluation de la performance de la fusion de données provenant de plusieurs capteurs pour la frégate de patrouille canadienne.

TABLE OF CONTENTS

| | | |
|-----|--|-----|
| | ABSTRACT/RÉSUMÉ | i |
| | EXECUTIVE SUMMARY | v |
| | LIST OF ACRONYMS | vii |
| 1.0 | INTRODUCTION | 1 |
| 2.0 | EXPERIMENTAL DATA, TESTBED AND SIMULATIONS | 3 |
| 2.1 | Trial Data | 3 |
| 2.2 | Testbeds and Simulations | 8 |
| 2.3 | Real-Time MSDF Demonstration Model at Paramax | 9 |
| 3.0 | CASE_ATTII ALGORITHM-LEVEL TESTBED | 11 |
| 3.1 | Evolution | 11 |
| 3.2 | Design Strategy | 13 |
| 3.3 | Global Structure | 14 |
| 3.4 | Sensor Data Generation Module | 14 |
| 3.5 | Tracking Module | 22 |
| 3.6 | Data Extraction, Visualization and Analysis Module | 24 |
| 3.7 | Simulation Manager | 25 |
| 4.0 | MSDF FOR THE CANADIAN PATROL FRIGATE | 28 |
| 4.1 | Establishing the CPF Baseline Performance | 28 |
| 4.2 | Advanced Sensors and MSDF Concepts for Performance Improvement | 31 |
| 5.0 | CONCLUSION | 33 |
| 6.0 | REFERENCES | 35 |

FIGURES 1 to 11

TABLE I

UNCLASSIFIED

v

EXECUTIVE SUMMARY

Current Above Water Warfare (AWW) systems afloat are largely composed of stand-alone subsystems. Until recently, there has been a tendency for various AWW sensors and weapons to be conceived, developed and produced in isolation from each other. These components are only to be brought together on the ship and, there, superficially integrated. However, the development and/or acquisition of advanced AWW sensor and weapon elements, although necessary, are not sufficient for providing the required protection of ships against the anticipated future threats. The simple interfacing of the elements is not enough because such independent AWW components are seldom used in a coordinated manner. This typically leads to a confusing and time-late decision environment for the ship's commander. Hence, the effectiveness of the AWW system is not only determined by the capabilities of the AWW sensor and weapon suites alone, but also by the effectiveness of the AWW system integration which must focus on cooperative, synergistic and efficient utilization of all of the AWW sensor and weapon elements.

In this regard, the Command and Control Division at DREV is involved in multiple R&D activities in the field of local area Multi-Sensor Data Fusion (MSDF) for naval command and control afloat. One of the best tools to support these activities, and help the MSDF designer with the selection of techniques that are best suited to a specific problem, is a computer simulation. This document presents an overview of the algorithm-level simulation testbed that has been developed by DREV to support the MSDF R&D. It also discusses the use of this testbed in the framework of an ongoing MSDF performance evaluation study for the Canadian Patrol Frigate (CPF). The results of this study are of prime importance when considering the mid-life update of the CPF.

MSDF comes at a time when, potentially, the Canadian Forces will have to do more with less personnel. As the size of the Forces diminishes, the role of those who remain "ever-vigilant" increases in importance. The development of the simulation environment described in this report resulted in a major improvement of the knowledge base at DREV in the field of MSDF. Indeed, the knowledge, expertise and material gained as a result of this project provide DREV with the opportunity to take a leading role in the evaluation of current and future MSDF systems for the Canadian Forces. With this project, DREV also increased its capacity to advise the Forces in the selection of integrated surveillance and tracking systems suitable to fulfill their requirements, and in the optimization of the operation of these systems to obtain the best performance.

PRECEDING PAGE BLANK

UNCLASSIFIED

vii

LIST OF ACRONYMS

| | |
|----------------------|--|
| AAW | Anti-Air Warfare |
| ADT | Automatic Detection and Tracking |
| ASCACT | Advanced Shipboard Command and Control Technology |
| AWW | Above Water Warfare |
| C² | Command and Control |
| CANEWS | Canadian Naval Electronic Warfare System |
| CARPET | Computer-Aided Radar Performance Evaluation Tool |
| CASE_ATTI | Concept Analysis and Simulation Environment for Automatic Target Tracking and Identification |
| CCS | C ² System |
| CPF | Canadian Patrol Frigate |
| CRAD | Chief, Research and Development |
| CRDV | Centre de recherches pour la défense, Valcartier |
| CSTSF | Combat Systems Test and Support Facility |
| DAP | Data Analysis and Presentation |
| DAR | Data Acquisition and Recording |
| DIRP | Defence Industrial Research Program |
| DND | Department of National Defence |
| DREV | Defence Research Establishment Valcartier |
| E-O | Electro-Optical |
| ESM | Electronic Support Measure |
| GUI | Graphical User Interface |
| HR | History Recording |
| IR | Infrared |
| IRST | Infrared Search and Track |
| JPDA | Joint Probabilistic Data Association |
| JPDAF | Joint Probabilistic Data Association Filter |
| LAN | Local Area Network |
| LEWES | Lockheed Canada Electronic Warfare Environmental Simulator |
| MDS/MTT | Multiple Dissimilar Sensors / Multiple Target Tracking |
| MDS/MTTI | Multiple Dissimilar Sensors / Multiple Target Tracking and Identification |
| MFR | Multi-Function Radar |

PRECEDING PAGE BLANK

UNCLASSIFIED

viii

LIST OF ACRONYMS (cont'd)

| | |
|-----------------|---|
| MHT | Multiple Hypothesis Tracking |
| MSDF | Multi-Sensor Data Fusion |
| MTT | Multiple Target Tracking |
| NAAWS | NATO Anti-Air Warfare System |
| NETE | Naval Engineering Test Establishment |
| NN | Nearest Neighbor |
| NTDS | Naval Tactical Data System |
| NWS | North Warning System |
| OO | Object Oriented |
| PDA | Probabilistic Data Association |
| PHIGS | Programmer Hierarchical Interactive Graphic System |
| PMAS | Performance Monitoring and Analysis System |
| R&D | Research and Development |
| RMCC | Royal Military College of Canada |
| SDTF | Software Development Test Facility |
| SEFCOR | Seaborne Fire Control Radar |
| SHINPADS | Shipboard Integrated Processing and Display System |
| STIR | Separate Track and Illumination Radar |
| SS/MTT | Single Sensor / Multiple Target Tracking |
| SS/MTTI | Single Sensor / Multiple Target Tracking and Identification |

UNCLASSIFIED

1

1.0 INTRODUCTION

In the past few years, a lot of effort within the C² Division at DREV has been directed towards the automation of C² processes for managing the information and allocating the resources by which the naval commander can exercise command and control in actual and future Above Water Warfare (AWW) scenarios. An appropriate conceptual framework (Ref. 1) describing the C² process in the context of a single naval platform (or single ship) puts in perspective three critical issues for the evolution of naval C²: data fusion, situation assessment and resource management.

A research project has been undertaken by the Data Fusion group to investigate in depth issues related to Multiple Target Tracking and Identification using Multiple Dissimilar Sensors (MDS/MTTI), which is generally referred to more simply as Multi-Sensor Data Fusion (MSDF). The objective of this project is to analyze, evaluate and develop advanced techniques to automatically produce the optimal estimate of the position, kinematic behavior, and identification of all objects surrounding a single ship, mainly through the fusion of data from dissimilar organic sensors (e.g., radar, E-O, ESM), while including inorganic information (e.g., data coming over communication links, intelligence reports, etc.). The use of the latter type of information is directed towards the potential enhancement of the performance of the different sensor data fusion subprocesses. The end result of MSDF (i.e., a highly reliable computation of the tactical picture) is used as an input to the subsequent, higher level situation assessment and threat evaluation C² processes.

An overview of the R&D activities involving the Data Fusion group in the field of local area MSDF for naval command and control afloat (including a description of the fundamental research that has been driven by DREV) is presented in a separate document (Ref. 1). One of the best tools to support these activities, and help the MSDF designer with the selection of techniques that are best suited to a specific problem, is a computer simulation. This document presents an overview of the algorithm-level simulation testbed that has been developed by DREV to support the MSDF R&D project.

This document is organized as follows. Chapter 2 discusses the tool sets and trial data sets that are available for supporting research activities in the MSDF domain. A description of the CASE_ATTII (Concept Analysis and Simulation Environment for Automatic Target Tracking and Identification) algorithm-level simulation testbed developed

UNCLASSIFIED

2

at DREV is given in Chapter 3. CASE_ATTI provides the highly modular, structured and flexible hardware/software environment necessary to study and compare various advanced MSDF concepts and schemes in order to demonstrate their applicability, feasibility and performance.

In Chapter 4 we discuss how CASE_ATTI is currently being used to support the development and evaluation of advanced sensor data fusion concepts in the context of the CPF.

The R&D activities described in this document were performed at DREV between 1990 and 1994 under PSC 12C, Ship Combat System Integration.

2.0 EXPERIMENTAL DATA, TESTBED AND SIMULATIONS

Part of the overall MSDF techniques analysis, development and evaluation process involves the decision regarding the approach or means that will be used for conducting these research activities (Ref. 2). A characterization of the overall spectrum of possible tools is shown in Table 1, adapted from Ref. 2. This broad spectrum ranges from using very simple computer simulations supporting rigorous mathematical analyses, to actually testing prototypes during live military exercises. Generally, as is depicted in Fig. 1, also adapted from Ref. 2, there are tradeoffs in selecting one approach over the other. The most obvious one is probably the level of operational realism obtained versus the costs.

The ultimate test to evaluate the military value of a prototype would be to use it in live military exercises. Such an environment provides reasonably high fidelity operational conditions since the real-world physics, human, equipment and tactics/doctrine can be taken into account. However, there are major drawbacks to this approach. The system designers typically cannot have full control of the events, and it is difficult to collect the relevant data. In particular, precise truth data that are needed for MSDF performance evaluation can be hard to obtain in real-world tests; these are however readily available in computer simulations. The latter typically constitutes very controlled research environments that offer a high level of convenience and flexibility at low costs. Unfortunately, digital simulations cannot always adequately represent complex real-world phenomena and human behavior. Specialized field data collection campaigns can be a good compromise between these two extremes. Indeed, this approach is often used to validate computer simulations. However, such trial activities can rapidly become very costly.

This chapter discusses the tool sets and trial data sets that are available for supporting the research activities under the MSDF project.

2.1 Trial Data

Given the level of realism that they provide for system design and evaluation, high-quality trial data sets are a goal that the Canadian MSDF community should be seeking. There is indeed an urgent need for data sets from real sensors and targets, even though such sensor-target pairs may only be representative for a specific variety of applications. To date, however, very little calibrated and simultaneously collected data on targets of interest

| Toolset | Characteristics | | | | |
|--|--|---|---|---|---|
| <p>Digital Simulations</p> <ul style="list-style-type: none"> • Level 1: Engineering Models • Level 2: 1 vs N • Level 3: M vs N • Level 4: Organizational Level • Level 5: Theatre Level • Numerous MSDF Process Models | <ul style="list-style-type: none"> • Relatively high fidelity; explore physics and 1 vs 1 problem <table border="0" style="margin-left: 20px;"> <tr> <td style="font-size: 2em; vertical-align: middle;">}</td> <td style="vertical-align: middle;">Engagement Models</td> <td style="font-size: 2em; vertical-align: middle;">{</td> <td style="vertical-align: middle;"> <ul style="list-style-type: none"> Explore engagement effects Fidelity decreases with level Engagement complexity increases with level </td> </tr> </table> <ul style="list-style-type: none"> • Individualized, ad hoc simulations for tracking, ID, detection; statistical qualification usually feasible. | } | Engagement Models | { | <ul style="list-style-type: none"> Explore engagement effects Fidelity decreases with level Engagement complexity increases with level |
| } | Engagement Models | { | <ul style="list-style-type: none"> Explore engagement effects Fidelity decreases with level Engagement complexity increases with level | | |
| <p>Hybrid Simulations</p> <ul style="list-style-type: none"> • Man-in-the-loop and/or • Equipment-in-the-loop | <p>Important effects of real humans and equipment; more costly; statistical qualification often unaffordable.</p> | | | | |
| <p>Specialized Field Data Collection / Calibration</p> | <p>Real-world physics, phenomenology; relatively costly; often used to verify/validate digital simulations; good for phenomenological modeling but not for behavior modeling; statistically controlled in most cases.</p> | | | | |
| <p>Test Range Data Collection</p> | <p>Real-world physics, humans, equipment; relatively costly; can do limited engagement effects studies; some behavioral effects modeled; statistically uncontrolled.</p> | | | | |
| <p>Live Military Exercises</p> | <p>Real-world physics, human, equipment, and tactics/doctrine; costly; data difficult to collect/analyze; extended engagement effects studies at least feasible; extended behavioral effects modeled; statistically uncontrolled.</p> | | | | |

TABLE I - Generic spectrum of analysis / modeling / evaluation tools (adapted from Ref. 2)

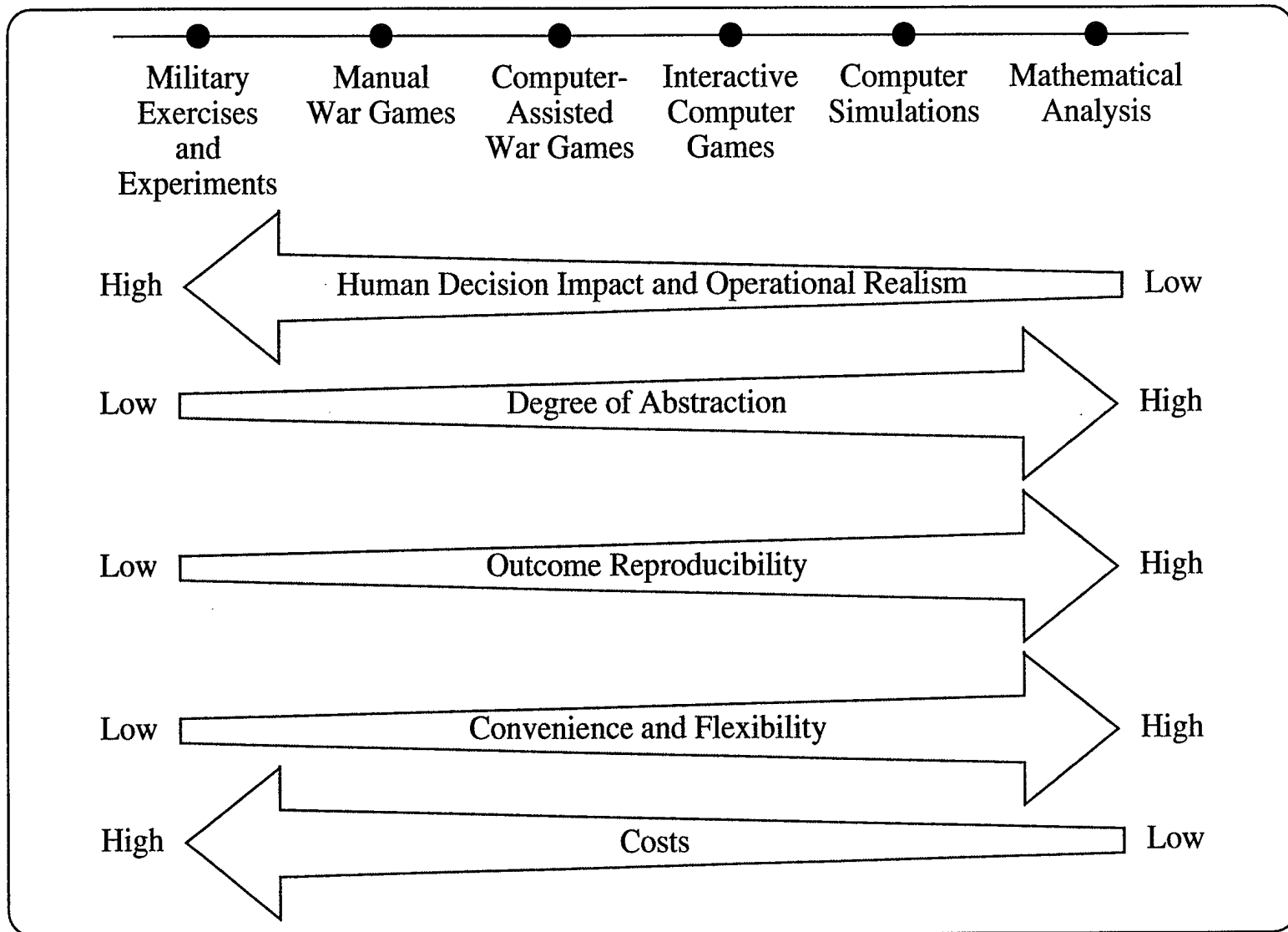

FIGURE 1 - Tradeoffs in analysis / modeling / evaluation approaches (adapted from Ref. 2)

UNCLASSIFIED

6

exists. And this is especially true for the case of dissimilar sensors. Only a few organizations, almost exclusively located in the US or Europe, have invested in the collection of such trial data. Given various political factors and the cost of such collection operations, these data are usually very sensitive and typically become (appropriately) proprietary. As a result, the MSDF designers must most of the time content themselves with trial data that have only a limited relevance to MSDF.

2.1.1 AN/SAR-8 Performance Assessment Trial Data

There is an opportunity in Canada to evaluate experimentally the performance of dissimilar sensor data fusion by analyzing the AN/SAR-8 land-based trials database presently held at NETE (Naval Engineering Test Establishment) in Montreal. This database contains radar and AN/SAR-8 (IRST) data with time stamp that were recorded on a variety of air targets (Ref. 3). A considerable effort has already been done by NETE for preprocessing the data.

There are, however, a number of drawbacks to using this trial database for data fusion purposes. The most obvious one is that the experiment was conducted in order to evaluate the performance of the AN/SAR-8 infrared sensor, not to study or validate MSDF concepts. The radar sensors were thus used only to help find the targets of interest (i.e., to establish some ground truth data for the AN/SAR-8 evaluation). Moreover, these radars are not the ones that may interest the Canadian Navy.

2.1.2 The CPF Performance Monitoring and Analysis System

The Canadian Navy has long recognized the need for a shipboard system that can gather on-line, real-time data during surface-and-air weapon trials (Ref. 4). Indeed, the need for a tool that can continuously monitor and assess the combat readiness and performance of a ship's weapon and sensor subsystems has never been greater. The information gathered by such a tool would serve to validate combat simulation models whose results must themselves be validated against live data.

For the CPF, a history recording (HR) capability was incorporated at the CCS level. Unfortunately, HR captures only combat system data which has already been processed by the CCS software modules. Moreover, the in-depth analysis and presentation of the HR data can only be done ashore, rendering a quick assessment of a trial impossible.

UNCLASSIFIED

7

Although some weapon and sensor subsystems possess limited data logging and reduction capabilities, there is no provision for synchronizing data collection or correlating significant events between each subsystem. For these reasons, a CRAD-funded prototype surface-and-air weapon monitoring and analysis system was developed specifically for CPF acceptance trials and future combat system trials. The Performance Monitoring and Analysis System, or PMAS as it is called, comprises separate subsystems for data acquisition and recording (DAR), and for data analysis and presentation (DAP).

The CPF combat system architecture is characterized by several separate processes exchanging information via a communication network. The CPF distributed architecture utilizes the global system bus, SHINPADS, to communicate between several AN/UYK-505 computers and AN/UYQ-501 displays. Furthermore, each AN/UYK-505 computer contains dedicated software modules that handle the Naval Tactical Data System (NTDS) interfaces to the off-the-shelf sensor and weapon subsystems. The major components of the AWW system whose interfaces (NTDS A, B and D) can be tapped and analyzed by the PMAS include the Separate Track and Illumination Radar (STIR) control console, the SPS-49 long-range radar, the Sea Giraffe medium-range radar and their associated CCS software modules. The DAR subsystem of PMAS is based on five tap units which provide a transparent passive connection to the interface components of the CPF combat system. These tap units monitor the NTDS interfaces and, upon time synchronization, record the message traffic. The system time, stamped on all tap unit recordings, is synchronized to enable post-trial correlation of each interface's message data. The tap units can also filter the recorded messages to remove unwanted and periodic non-changing messages before the data is viewed by the tap unit operator or transferred to the DAP subsystem of PMAS. The latter is used to gather data from all interfaces being tapped by the DAR subsystem. This voluminous data is then reduced, converted to engineering units and placed into a relational database from which it can be extracted for report generation.

In view of what has been discussed above, it seems obvious that PMAS could be used as the basic means supporting a specialized field data collection operation dedicated to the investigation of MSDF concepts for the CPF. The PMAS capability to acquire and record CPF sensor data, including CANEWS ESM data (tests have been run at the Fleet Software Support Centre where NTDS interfaces are used by the CANEWS software testing facility), could be used for that purpose during military exercises involving the CPF. However, despite its good design and implementation, PMAS represents only the

UNCLASSIFIED

8

tool required to collect/analyze sensor data. A well controlled experiment dedicated to the study of MSDF issues and involving humans, equipment, tactics/doctrine, extended engagements, etc., still remains to be designed and set up. This would require a tremendous amount of preparation and may result in a very costly operation. No concrete steps have been taken so far in this direction.

2.2 Testbeds and Simulations

The extremely limited availability of trial data to support algorithm development and MSDF system prototypes represents a serious detriment to the Canadian MSDF community. Many research programs whose focus is on MSDF algorithm analysis and development, such as the one of interest in this document, cannot afford to incur additional costs of data collection for the purpose of demonstrating algorithms with real data. Alternatives to this situation include artificially synthesizing multi-sensor data from individual sensor data collected under non-standard conditions (not easy to do in a convincing manner), or to employ high-fidelity sensor and phenomenological simulators. This last option has been retained for the MSDF project at DREV since, most of the time, representative simulated data may be sufficient to verify or validate MSDF concepts.

2.2.1 Parametric-Level Testbeds

Over the last several years, the defence community has built up a testbed capability for studying various components of the MSDF process (Ref. 2). In general these testbeds have been associated with a particular program and its range of problems and, except for a few instances, they have permitted *parametric-level* but not *algorithm-level* experimentation. That is, these testbeds, as software systems, were built from "point" designs for a given application wherein normal control parameters could be altered to study attendant effects, but these testbeds could not (at least easily) permit replacement of such components as a complete tracking algorithm.

The small-scale computer simulation model developed under the DIRP by Thomson-CSF Systems Canada (Refs. 5-7) is a good example of such a parametric-level testbed. This PC simulation environment has been specifically implemented to compare the tracking performance of four types of MSDF architecture for a given multiple target scenario, and quantify the advantages and drawbacks of each approach. The user can define and save the true target trajectories and the scenario to be used in the simulation. He

UNCLASSIFIED

9

can also specify whether the radar measurements will be created for the current run or will be read from an existing disk file. The user can choose the type of tracking architecture to be simulated, but cannot modify the actual implementation of this architecture; the tracking algorithms are hard-coded. The flexibility of this testbed is thus limited to the variation of a few scenario parameters such as the target/ownship geometry.

2.2.2 Algorithm-Level Testbeds

High-fidelity simulation environments that permit algorithm-level test and replacement are required for the investigation of advanced, state-of-the-art MSDF algorithms and techniques. Recently, some new testbed designs are moving in this direction. Two examples are the "Multisensor, Multitarget Data Fusion Testbed" developed by Rome Lab (Ref. 8) and the "Integrated Testbed" developed within the Command and Information Systems Division of Deutsche Aerospace in Germany (Ref. 9). However, both of these environments are not tailored to naval applications. Two other of these new tools are the MSDF demonstration model currently being developed under the Defence Industrial Research Program (DIRP) by Paramax Systems Canada in Montreal (Refs. 10-13), and the Concept Analysis and Simulation Environment for Automatic Target Tracking and Identification (CASE_ATTII) system developed by DREV (Refs. 14-18). Both of these testbeds are further discussed below (the description of CASE_ATTII constitutes Chap. 3).

2.3 Real-Time MSDF Demonstration Model at Paramax

Under contract with DREV, as discussed in Ref. 1, Paramax Systems Canada analyzed the feasibility of implementing an MSDF function for the current sensor suite of the CPF, within the CPF operational land-based test facility at Paramax in Montreal (i.e., originally the Combat Systems Test and Support Facility (CSTSF), recently renamed as Software Development Test Facility (SDTF)) (Ref. 19). As a follow-up to this feasibility study, Paramax submitted a DIRP proposal entitled "Implementation of Sensor-Level Hard Fusion for CSTSF Sensors" (Ref. 10), with DREV as scientific advisor.

One objective of this R&D activity is to establish a facility (or demonstrator) in the CSTSF/SDTF real-time naval CCS to use the data provided by the current sensor suite of the CPF for MSDF purposes. Given that it is developed within the CPF operational land-based test facility, this algorithm-level MSDF demonstrator is provided with a level of realism with respect to the CPF that can hardly be matched by any other simulation

UNCLASSIFIED

10

environments. It will provide a capability to demonstrate and quantitatively measure the CCS performance with and without MSDF, using the same simulation environment and real-time operational scenarios that were used for the development of the CPF CCS software.

However, as was previously discussed in the beginning of this chapter, there are always tradeoffs to be made between the level of operational realism of a testbed and other factors such as costs or flexibility. For example, the software design strategy for the development of the MSDF system demonstration model is to ensure minimal changes to CPF CCS. The only CCS modifications are to sensor interface modules which have to broadcast sensor data as soon as received with no impact on CCS operations. On one hand, this guarantees that the performance changes are only due to the incorporation of MSDF. On the other hand however, this design strategy was imposed by the high costs (and other political and operational constraints) associated with any modification to the CSTSF/SDTF environment. This may become very restrictive in terms of research flexibility. For example, the MSDF architecture that was selected for implementation and investigation within the current testbed is the sensor-level architecture, although one can prove this is not the most optimal one. This is because the current sensors on the CPF have their own Automatic Detection and Tracking (ADT) subsystems so that these sensors provide tracks to the CCS. The study of the central-level architecture would necessitate serious modifications to the CSTSF/SDTF (or even worse to the sensors themselves) in order to have access to contact data from the sensors; these modifications could be relatively costly.

Because tracking techniques implemented in the current sensors of the CPF are very limited when compared with more advanced algorithms that can be found in the literature, the MSDF techniques that have been selected for implementation in the current testbed are also very simple. Since the MSDF demonstrator design has great potential for growth, more sophisticated MSDF techniques and algorithms could be implemented and studied; in that sense the demonstrator is an algorithm-level testbed. However, to take full advantage of it, costly modifications to the CSTSF/SDTF simulation environment would again be required.

Other drawbacks associated with this testbed are the use of Ada (limiting the flexibility) for the fusion software and the lack of access to ground truth data for on-line performance evaluation. Nevertheless, despite its associated constraints, the real-time

UNCLASSIFIED

11

MSDF demonstration model developed by Paramax remains a highly valuable tool that is expected to play a major role in the implementation of an MSDF capability onboard a real CPF at sea.

3.0 CASE_ATTI ALGORITHM-LEVEL TESTBED

An important R&D activity undertaken by the C² Division at DREV addresses the MSDF critical issue for the evolution of naval C² within the Canadian Forces. Within this activity, an algorithm-level testbed has been developed (and is being enhanced on a regular and progressive basis) for proof-of-concept purposes. A description of this testbed, called Concept Analysis and Simulation Environment for Automatic Target Tracking and Identification (CASE_ATTI), is given in this chapter.

3.1 Evolution

Figure 2 illustrates the evolution of the CASE_ATTI system. DREV has long recognized the fact that one of the best tools to help a designer in evaluating a target tracking solution is a software testbed (Ref. 20). The development of a simulation environment was thus undertaken in 1990 and a first prototype with limited capabilities was produced. This prototype is a Single Sensor/Multiple Target Tracking (SS/MTT) simulation environment which is fully described in Ref. 21. The prototype is limited because it supports only single-sensor scenarios and it does not include the target identification process. Despite these limitations, this environment can be used to investigate advanced SS/MTT concepts. Indeed, it has been successfully used in a joint study with the research group on data fusion at the Royal Military College of Canada (RMCC) to investigate the applicability of expert systems to help in the management and display of the hypothesis tree of the Multiple Hypothesis Tracking (MHT) algorithm (Refs. 22-23).

During the second half of the 80s, RMCC developed disparate, non-reusable pieces of software to fulfill the requirements of DREV's contracts on Kalman filtering concepts. In order to study more complex tracking problems, RMCC evolved their software to an SS/STT simulation. At the same time, a SS/MTT simulation environment was being developed at DREV. To avoid duplication, a new project was then defined by DREV to develop a high quality simulation environment specifically dedicated to MSDF studies. As a result, RMCC was tasked by DREV at the beginning of the 90s to undertake the development of CASE_ATTI.

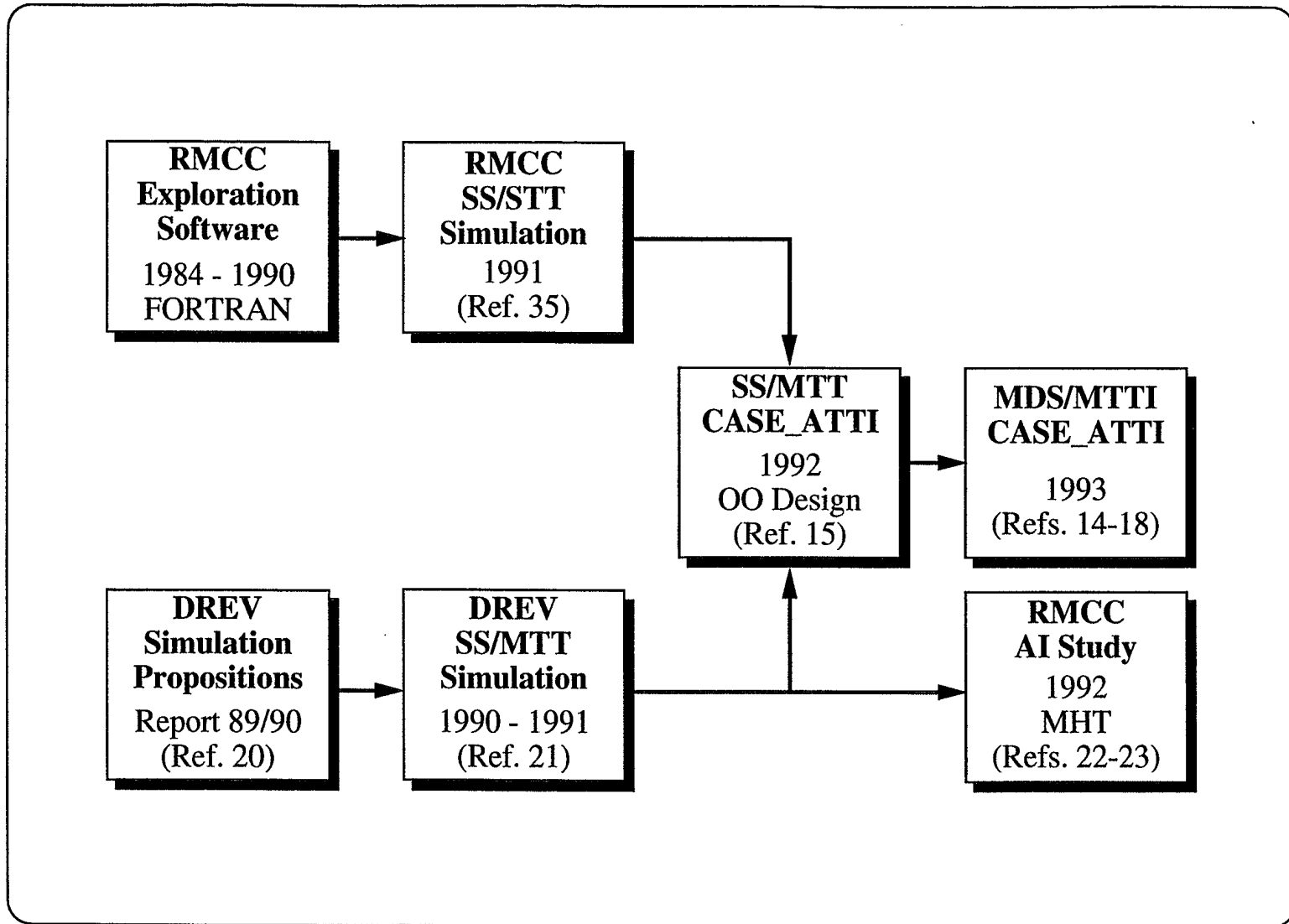

FIGURE 2 - Evolution of the CASE_ATTI system

UNCLASSIFIED

13

The primary requirement for this development activity was to provide DREV with the highly modular, structured and flexible hardware/software environment necessary to study and compare various advanced MSDF concepts and schemes in order to demonstrate their applicability, feasibility and performance. This requirement yielded the first true prototype of the CASE_ATTII system (Ref. 14). It was immediately followed by a multi-sensor version including target attribute fusion (Refs. 15-18). This new environment exploits the recent developments in the software engineering domain (e.g., object-oriented programming, advanced software development tools, advanced graphical user interface concepts and building tools, etc.), and the availability of more powerful computer platforms. The following sections provide the reader with some understanding of how the CASE_ATTII system is designed and how the tool can be used to aid a designer in evaluating MSDF algorithms and techniques. A more complete description can be found in Refs. 14-18.

3.2 Design Strategy

Several criteria must be met when developing such a MSDF testbed. It must be modular to allow for flexibility in the testing of various configurations and to allow for easy alterations or customizing in the future. The design must allow the users to easily develop and incorporate their own tracking algorithms, sensor models, and analysis tools. It must provide realistic sensor data to the algorithms, taking into consideration such items as environmental conditions (ultimately, the ability to utilize true sensor data would remove any uncertainty in the results of the tracking on artificial sensor data). In addition, the testbed must present the results to the user in a useful and manageable way. The user must be able to animate the selected scenario, to view the results of the algorithms while tracking, to select statistics and have them presented in an intuitive manner. It must also aid the user in designing an experiment. When creating a scenario, the user must be able to easily configure the sensors, the platforms on which the sensors are stationed, the targets and their attributes, the trajectories of the targets, as well as the MSDF algorithms. CASE_ATTII adheres to all of the above criteria.

The modularity, flexibility, efficiency and speed of the CASE_ATTII system are highly dependent on the selected hardware platform and software design. The CASE_ATTII testbed has been implemented on an HP/Apollo 9000, series 700 workstation. However, the design has the capabilities of utilizing multiple computers across a Local Area Network

UNCLASSIFIED

14

(LAN). The design criteria discussed above and portability requirements dictated to a large extent the software platform that has been employed. The present software platform, illustrated in Fig. 3, consists of UNIX (HP-UX), XWindows for the user interface, PHIGS for the graphics, and C++/C.

The ability of the system to meet its objectives is largely based on its object-oriented (OO) design. Such an algorithm-level software testbed for MSDF is a very complex system. The OO paradigm has been utilized to decompose complexity into manageable objects. This ability to present different levels of abstraction provides a better presentation and understanding of the problem to different users (Ref. 24). The simulation is more intuitive and easier to understand when it is described as objects. The C++ language was used since it supports the object-oriented paradigm. It utilizes data abstraction, encapsulation, hierarchies, modularity, polymorphism and concurrency. C++ is also efficient and allows for the inclusion of algorithms that have already been developed in the C language.

3.3 Global Structure

The CASE_ATTI testbed has been divided into four major sub-blocks. This division simplifies the problem both conceptually and technically. Figure 4 shows a simple block diagram representation of these main modules. For any MSDF system simulation, the scenario configuration is handled by the simulation manager, the generation of sensor data is handled by the sensor module, the MSDF architecture is simulated within the tracking module, and the assessment of the results is provided by the data extraction, visualization and analysis module. Each module is a separate process with a means of communicating with the other processes. This independence between modules allows the simulation to be divided amongst several computers on a network. Each module is itself broken into blocks which account for the modules flexibility. To gain better understanding of the testbed, further elaboration of these modules is given in the following sections.

3.4 Sensor Data Generation Module

As illustrated in Fig. 5, a typical simulation scenario consists of platforms (e.g., ships) with sensors, and targets. The platforms can be stationary or moving along given paths. One or more potentially-dissimilar sensors (such as radar, infrared, ESM, etc.) can be assigned to each platform. Targets are created with defined attributes and trajectories.

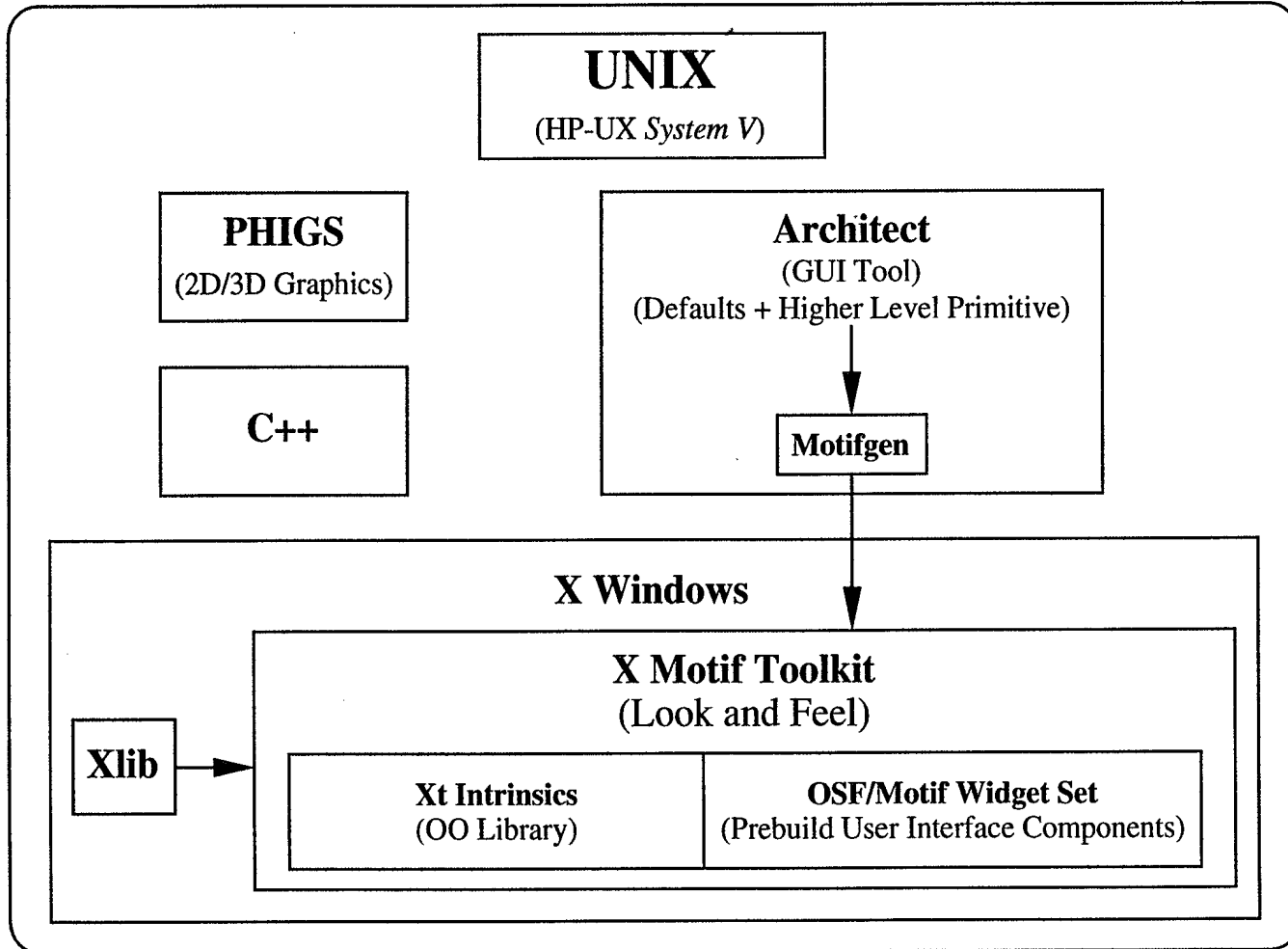

FIGURE 3 - CASE_ATTI software platform

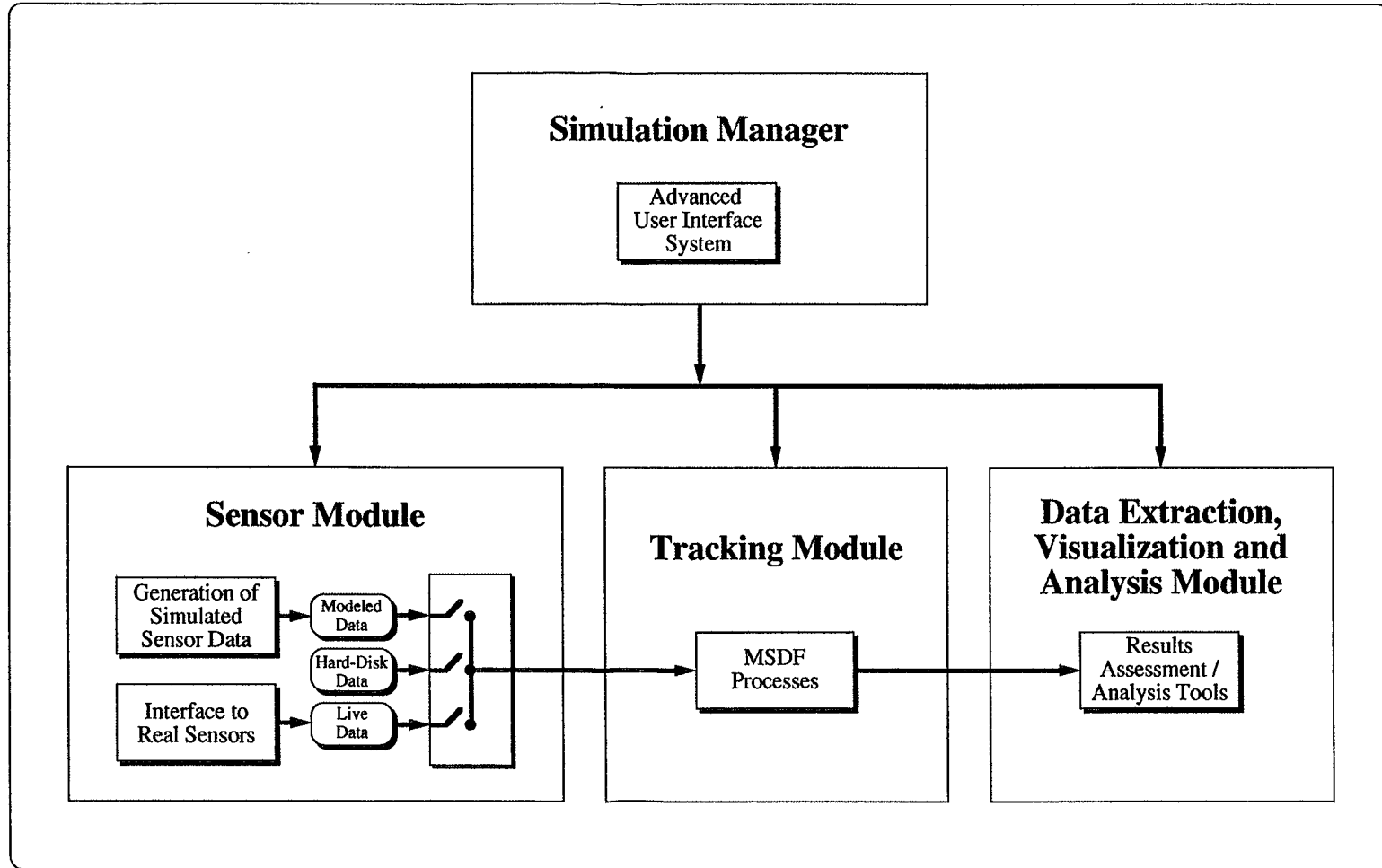

FIGURE 4 - CASE_ATT global structure

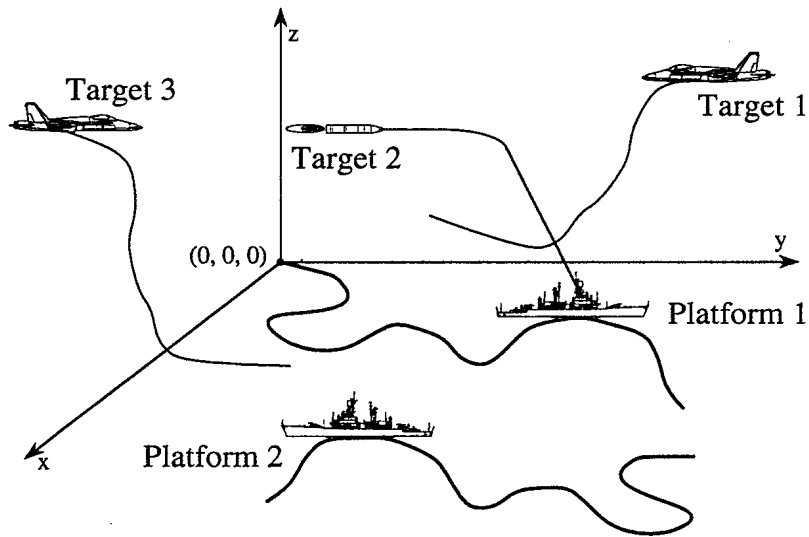

FIGURE 5 - Typical scenario

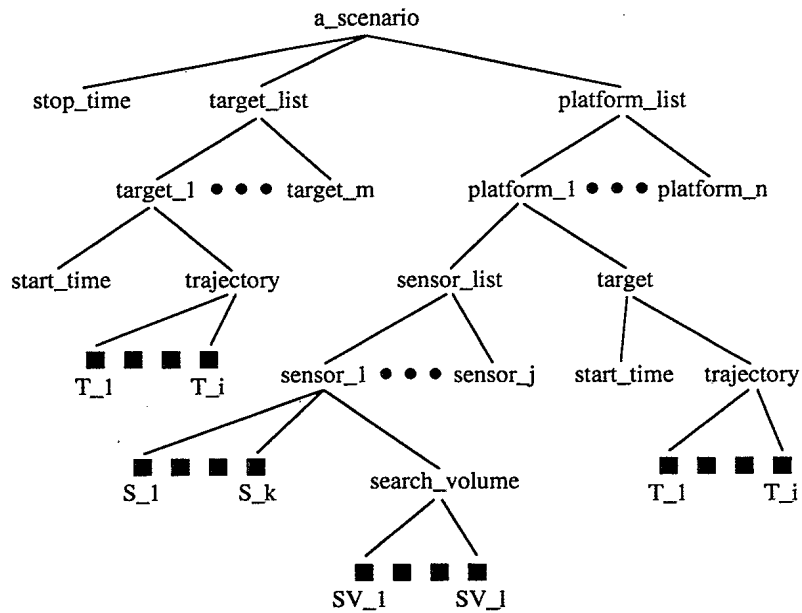

FIGURE 6 - Sensor data generation scenario hierarchy

UNCLASSIFIED

18

The scenario also allows for the selection of environmental conditions that may affect the various sensor measurements.

The sensor data generation scenario hierarchy implemented in the CASE_ATTII testbed is displayed in Fig. 6. Lists of platforms, sensors, and targets must be provided by the user. It is worth noting that any given platform is considered as a target for the other platforms. A trajectory must be specified for each target (and platform), and a search volume must be specified for each sensor. All scenarios have the same basic structure.

The sensor module is responsible for providing realistic measurement data to the tracking algorithms. Given a user-defined scenario as described above, it generates true target positions and measured target positions, which are subsequently made available to the tracking module. The sensor module is built on several levels of abstraction, each abstraction providing new details and perspective while at the same time hiding unwanted details for the next level (Refs. 15-16). As shown in Fig. 7, it is composed of several objects, the main ones being platform controller, platform, sensor and target container. The remainder of this section briefly describes these objects and their interaction to produce the required data for the tracking module.

The platform controller can be thought of as a hub that is responsible for collecting information from the various platforms, and for organizing this information for distribution either to the tracking or to the graphics display modules. The platform controller's responsibilities are thus to create and initialize (or configure) each platform in the scenario and to manage these platforms after each configuration. The latter involves updating each platform and requesting the correct platform for measurements. At this highest level of abstraction the platform controller hides the details of sensor simulation from the programmer. The programmer knows there is an object that controls the platforms in the scenario and that this object will return measurements, but how these measurements are generated is unknown to his perspective.

All sensors are mounted on some type of platform that can be moving or be stationary. A platform can also be underwater, on the surface or airborne. Each platform must react to requests from the platform controller. Typical requests are to advance to the next event time and to obtain from the platform its location, the type of sensors assigned to it, and a list of measurements. This is the second level of abstraction. The details of

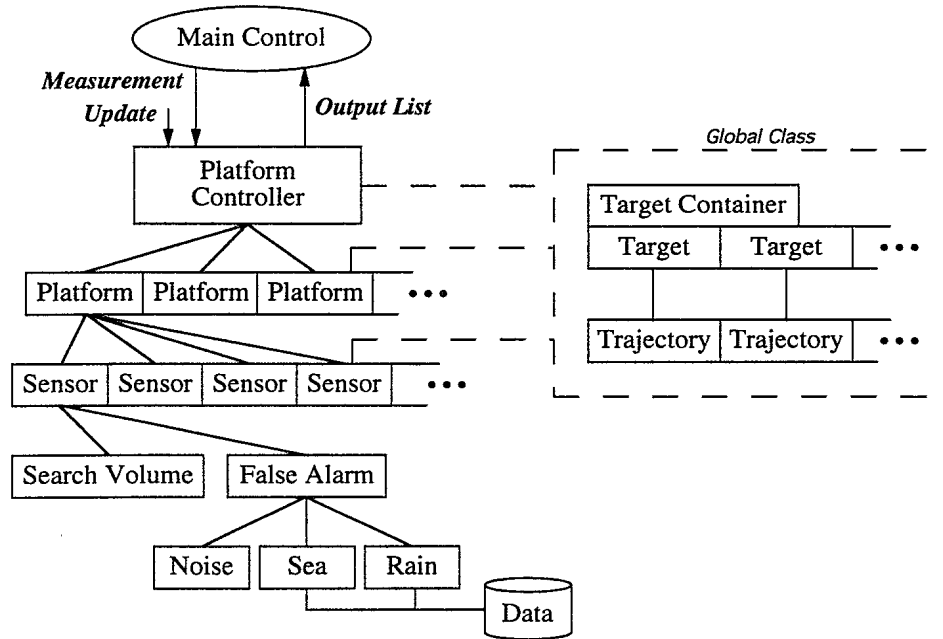

FIGURE 7 - Sensor module object communication structure

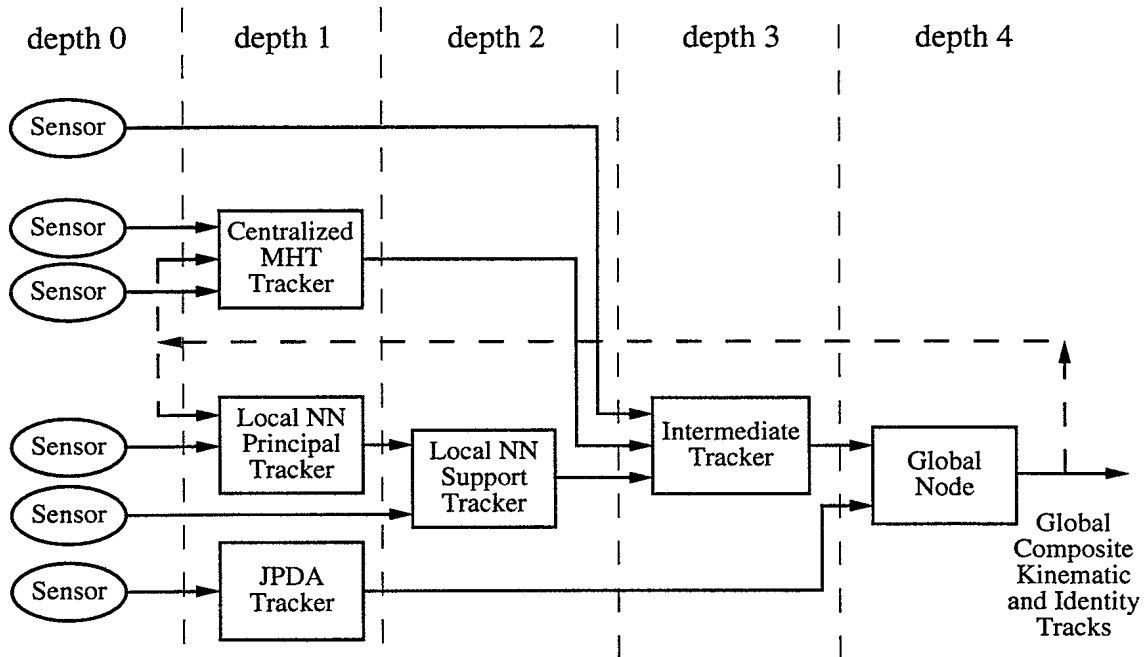

FIGURE 8 - An example of a multi-tiered generalized tracker

UNCLASSIFIED

20

configuring and positioning the sensors, and the method of generating the measurements, are hidden from the platform controller.

At the next level of abstraction, the sensor object represents the specific type of sensor that is being modeled. As illustrated in Fig. 7, the sensor object collaborates with several other objects to create the required behavior. Collaboration occurs with the target container, false alarm, and search volume objects in producing the required measurements. The target container manages all targets in the simulation, and all requests to targets must pass through this class. The target object is an abstraction of a real-world object that can be viewed by a sensor. For example, a target may be a plane, a ship, a missile, a bird, etc. One of the main properties associated with a target is its trajectory.

The sensor object has to respond to requests from the platform for measurements, next time update, and location of the sensor. Since a platform may contain several dissimilar sensors, it is important for reuse and extensibility that a common interface be utilized for each sensor. This is easily performed in the object-oriented language of C++, which supports single and multiple inheritance, since the user is free to reuse any level of abstraction. A generic sensor class has been defined; it can be represented as a tree structure with various specialized sensors extending from it. Any new sensor model is derived from this generic base sensor. This greatly simplifies the development of such a new sensor component since each specialization of the sensor, be it an infrared, a radar or a data file, must inherit this common interface to the platform. As a result, each sensor can have a completely different representation behind this interface, and other sensor models previously derived from this base sensor would not be altered by the addition of a new model. Utilizing this inheritance feature limits the number of alterations to existing code and thus aids in maintaining the integrity of the existing system.

Timing is an important issue for the sensor data generation process. The procedure for obtaining measurements is performed in two steps. The first one is to advance the simulation clock, that is, to select the next platform or sensor to be requested for measurements. The second step is to request these objects for measurements. The platform controller initiates a clock-advance by sending an update message to the platform that has produced the last set of measurements. This platform in turn requests the sector time for the sensor that produced the measurements for the platform. The sector time will determine when the sensor will next produce measurements. The platform uses this time to order its

UNCLASSIFIED

21

sensors by next event (i.e., all sensors are ordered in a queue with the sensor to produce measurements next at the front of the queue). The platform then updates the time it will next produce measurements and returns this time to the platform controller object which orders the platforms by next event. When control has returned to the platform controller object, the sensor module has completed the clock-advance. The objects are now awaiting the second step, which is the request for measurements. It is initiated by the main program of the sensor module, and is directed to the platform controller which will then request the appropriate platform to produce measurements. This request is taken from the platform and handed to the appropriate sensor, which is stationed on the platform. The sensor must produce the required measurements.

The types of sensors that are currently inherited from the generic sensor (or base class) are radar, infrared, data, and artificial. The radar class represents a surveillance radar sensor whose model has been developed at DREV. This model is specifically dedicated to sensor integration and data fusion studies (Ref. 25). The aim of the design was to propose the highest possible level of radar simulation while ensuring that the major perturbing effects on sensor data fusion were adequately represented. In the model derivation, the characteristics of the radars to be installed on CPFs have been used as a reference.

The infrared model works in a similar fashion as the radar model. However, the detection computation is based on calculating the radiance contrast between a target and its background (Ref. 26).

The class artificial represents a simplified, academic-type sensor. This type of sensor does not attempt to reproduce accurately the behavior of a real sensor. However, it provides sufficient information to test the tracking algorithms. It is also quicker to implement, and gives the user a greater flexibility. The detection and false alarm probabilities are both fixed to values set by the user. One can also select which target parameters will be measured by the sensor. A typical example of an artificial sensor is a surveillance radar with an elevation measurement in addition to the range and bearing measurements.

The class data implements the mechanism by which externally generated sensor data (i.e., real or simulated, live or recorded sensor data generated outside of CASE_ATTII) can be incorporated into the CASE_ATTII environment in order to feed the platform object. The

UNCLASSIFIED

22

complexity of the measurement generation process for this sensor data is hidden or encapsulated within the class data. As a typical example, stimulation and simulation softwares of an ESM-type sensor (CANNEWS like) are already available from the Canadian industry. They could be used to produce ESM measurement outputs for specified threat scenarios. The resulting ESM data would then be integrated into the CASE_ATTII system, through the class data, to be used jointly with other sensor data (generated within CASE_ATTII for exactly the same scenarios).

3.5 Tracking Module

The ultimate CASE_ATTII system, as previously mentioned, must be a highly flexible simulation environment providing the algorithm-level test and replacement capability required for the investigation of advanced, state-of-the-art MSDF algorithms and techniques. As such, the tracking module must adapt to any type of tracking architecture for any scenario. Its design must have the capability of simulating a sensor-level, central-level or hybrid tracking architecture as required (Refs. 20, 27). The inheritance mechanism and a list implementation provide the flexibility to implement these types of architecture. As a result, the current tracking module supports a wide variety of tracker architecture types, varying from a simple single sensor tracker to an arbitrarily complex hierarchical multiple sensor topology such as the one illustrated in Fig. 8.

The object-oriented approach also facilitates the inclusion of new tracking algorithms into the existing tracking module (Refs. 14-17). At the top level of abstraction within this module is the class Tracker_list that contains a list of individual trackers, a description of the connection tree between the sensors and trackers along with tracker-to-tracker connections, and finally, a set of common tracker initialization parameters. Each tracker contains gating, association, assignment and filtering algorithms for incorporating new input information into existing internal tracks. Trackers within a Tracker_list are derived from a common base class, Tracker_object. The underlying structure of the individual trackers is hidden from the Tracker_list. The trackers within a Tracker_list are activated upon passing an input message with the appropriate measurements or tracks to the tracker. New trackers can be derived from a Tracker_object and added to the existing Tracker_list without having to alter the existing tracker classes, thereby providing considerable flexibility and consistency.

UNCLASSIFIED

23

At the start of the simulation, the Tracker_list reads in an initialization/configuration file for the user defined tracking architecture. This file contains a list of the required trackers to be created, common initialization parameters, and the network connections. Once configured, a Tracker_list simply ensures that data is forwarded to the appropriate destination in the correct order.

The tracking module supports depth control and event lists to handle an arbitrarily large and complex network of trackers. The depth parameter specifies the dependency between trackers. For example, consider the tracker illustrated in Fig. 8 of depth four. The Tracker_list passes sensor data reports to the appropriate trackers, and the trackers, in turn, create copies of these reports and insert events on the Tracker_list's event list, accommodating ordering due to time and depth. Upon the arrival of a sensor data report with a time tag greater than that of the head event, the Tracker_list stops collecting sensory input and starts processing the trackers listed in the event list beginning with the head event. As a result, the Tracker_list processes the trackers with a lower depth first and relays the resultant output data to the trackers of higher levels during the present scan. As new tracks are received by a tracker from a lower depth tracker, an additional event is inserted on the master event list. Any paths which pass data from a higher depth tracker to one with a lower depth are treated exclusively as feedback and are handled during the next measurement scan.

The tracking module can output data from any one of the trackers within the network to either the graphics/analysis module or a file. This feature allows an operator to examine the performance of any tracker within a potentially large and complex network of trackers. The tracking module can be executed on one or more machines. If all the trackers are run on a single machine, they will all co-exist as a single process to maximize efficiency. Alternatively, the tracking module offers the capability to employ additional computational resources over a network if available. For this case, the trackers are executed as separate processes, ideally one process per machine. The specifications for the distribution of the Tracker_objects is provided in the initialization/configuration file. The remote process handler is implemented at the base class level to standardize the communications interface between the individual trackers.

UNCLASSIFIED

24

The sensor-level trackers currently implemented include:

1. Multiple-Hypothesis Tracker (MHT)
2. Track-Split filter
3. Nearest-Neighbor type trackers (both Munkres-based and optimal)
4. (Joint) Probabilistic Data Association filter (JPDA/PDA)

The MHT implementation is capable of handling multiple simultaneous reports from different sensors; the other trackers are capable of handling single sensor reports at a time. A global track fuser using a version of the MHT tracker for assignment has also been provided to fuse the sensor-level tracks to form global tracks. In addition, feedback of these global tracks to the local sensor-level trackers is allowed. Current efforts include provisions for advanced track management schemes such as a Hough-Transform based track initiator tracker, and support for configurations including both active and passive sensors.

3.6 Data Extraction, Visualization and Analysis Module

Ultimately, the performance of MSDF algorithms is judged by the success (or lack thereof) of the mission they support. However, such a global performance assessment is not appropriate during MSDF system development. With a complex computer simulation of a MSDF system comprised of many algorithms and processes, the system designer needs specific tests to untangle the effectiveness of any individual component. The development of a MSDF performance evaluation methodology is thus one aspect of the current research activity at DREV. A results analysis module implementing this methodology in CASE_ATTII is also under development. It will comprise a set of computer tools implemented in CASE_ATTII to help the MSDF designer in his assessment of the performance of the algorithms and techniques. These tools will support a tracking statistic compilation mechanism, the output of performance results in summary tables and listings, the plotting of statistics, etc. The results will be presented in a user-friendly manner to the operator of the simulation environment.

Currently, the results analysis module simply comprises a sophisticated graphics module. The purpose of this module is to aid in the evaluation of the tracking algorithms by showing images of the true target positions, measurements, clutter, track positions, and

UNCLASSIFIED

25

track measurement gates generated by the other modules (Refs. 14-16). It provides for a global view of the situation and allows a quick assessment of the tracking performance. The graphical user interface, shown on Figs. 9-11, has been designed to be interactive and user friendly. It enables the user to zoom into specific areas, select relevant information, rotate the scene, and animate the simulation through a user specified time window.

Both a three-dimensional perspective view and a two-dimensional radar-like view are provided. The radar view also supports both Cartesian and polar axes. A set of printed examples of the graphics and user interface are shown in Figs. 9 through 11.

3.7 Simulation Manager

The CASE_ATTII manager is an interface built on top of the simulation software. Its main purpose is to allow the user easy access to the simulation environment (Refs. 14-18). It allows the user to run or modify an existing scenario, or to create a new one.

In its present form, the manager consists of one main menu, on which the user is presented with a number of options. From this main menu the user is given different levels of access to the components of the scenario. Each component is stored in a particular format and has its own specific parameters. When the user makes a choice in the main menu, these specific parameters are automatically displayed in the specific editor for that particular component. Within this editor existing components may be displayed and/or altered, new components may be build and old components may be deleted.

The manager also contains two graphical editors, one for the sensor data generation scenario and one for the tracking module scenario (Ref. 18). The sensor module scenario is used to define how the targets, platforms and sensors interact. The tracking module scenario defines how the data from the different sensors is processed and fused. Within both of these two graphical editors, the user is presented with a graphical display of connected icons (similar to the tree shown in Fig. 6) that illustrates the overall scenario. This greatly facilitates the design and editing of the different simulation scenarios. The non-graphical component editors can also be accessed through the individual text icons to alter the configuration of the sensors, platforms, targets, tracking connections, and trackers.

Besides the editors, the manager contains code that implements an interface allowing the user to choose a scenario (i.e., data generation and tracking) to be run.

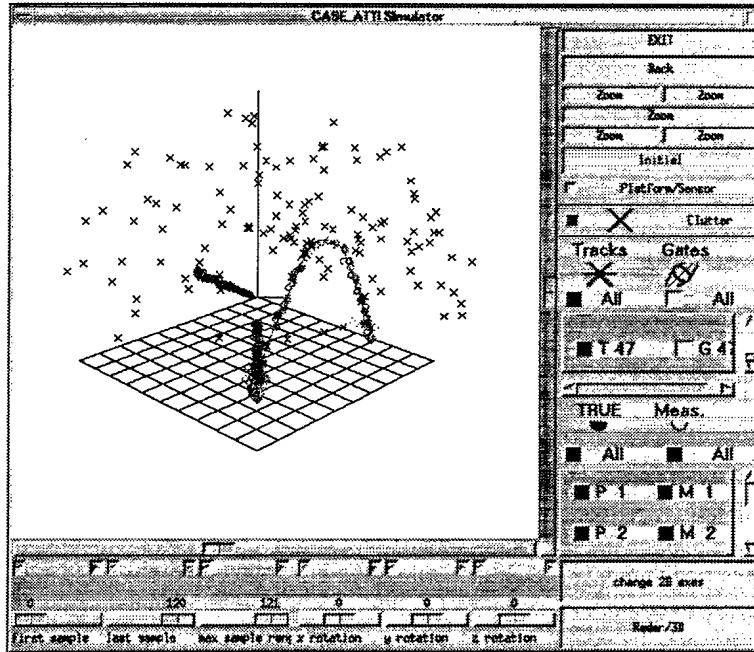

FIGURE 9 - CASE_ATTI graphics module 3D display

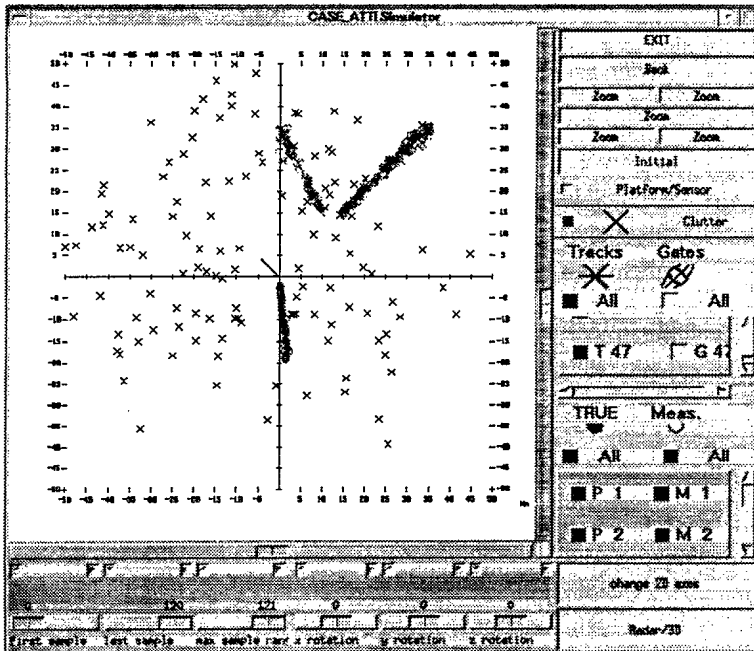

FIGURE 10 - CASE_ATTI graphics module 2D cartesian display

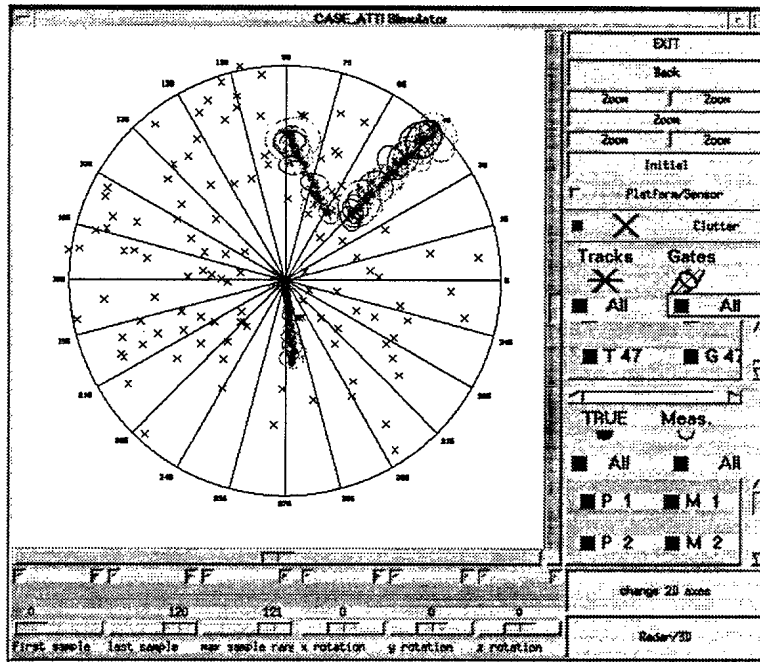

FIGURE 11 - CASE_ATTI graphics module 2D polar display

UNCLASSIFIED

28

4.0 MSDF FOR THE CANADIAN PATROL FRIGATE

Most of the current research in MSDF is dedicated to the development and application of new techniques, but little has been performed to determine how well such methods apply to a practical system. The CPF is a very interesting platform for MSDF application. In this chapter we discuss an ongoing study making use of the CASE_ATTII system to support the development of MSDF concepts that could apply to the current CPF sensor suite, as well as its anticipated upgrades (i.e., MFR, IRST, CANEWS 2), in order to improve its AWW performance against the predicted future threat. The study aims to identify and develop techniques for combining Radars/EO/ESM data, and to evaluate the real benefits of the combination. It will be conducted using mainly simulations and, where applicable, pertinent experimental data. Two major aspects need to be addressed for this application: first, the representation of the actual CPF sensor suite to establish its baseline performance, and second, the quantification of the performance improvements gained when using an upgraded sensor suite combined with advanced MSDF concepts. These two aspects are discussed in more depth below. Since this activity is only at a very early stage, the emphasis is given in this document to the incremental approach that will be followed and to the criteria that will be used to evaluate the performance and quantify the improvements. Actual results will be published in a subsequent document.

4.1 Establishing the CPF Baseline Performance

The definition of the CPF baseline performance for this study comprises two related aspects. Firstly, the performance of the current sensors operating in a stand alone mode is evaluated. Secondly, the global performance of the complete sensor suite is evaluated taking into account the limited integration that is performed within the current CPF Command and Control System (CCS). In both cases, it is assumed that the sensors are performing in accordance with their specifications. It is out of the scope of this project to verify if the sensors meet their specifications.

The current AWW sensor suite of the CPF comprises the SPS-49 long range 2-D radar, the Sea Giraffe medium range 2-D radar, the CANEWS ESM and the Separate Track and Illumination Radar (STIR). The performance of this suite of sensors may be assessed by flying known targets on predetermined trajectories and measuring, as an example, detection ranges and tracking performance for each sensor of interest and for the CCS track

UNCLASSIFIED

29

management module. However, this method is time-consuming and costly. The approach we propose privileges simulations. It is cheaper and faster than experimental methods and permits the repetition of tests under simulated conditions which may be difficult to obtain in practice, or for which one would have to wait for a very long time for a natural occurrence.

To establish the baseline performance of the current sensor suite, the detection, measurement generation and tracking behavior of each sensor must be adequately simulated. In terms of target detection, the simulation must not only account for the sensor's design parameters, but also for a number of other factors. In most cases, the simple radar equation based on free-space propagation yields far from accurate results and must be modified to account for multipath, ducting and other effects. A representation of the effect of the receiver front-ends, signal and data processing of each sensor is necessary.

The surveillance radar model used in this study takes into account all aspects of the radar-environment-target chain (Ref. 25). As such, the model is sophisticated and a validation of its behavior must be performed before the baseline performance can be evaluated. Based to a large extent on the available literature and on relevant experience and studies in the field, many aspects of radar behavior are well known and have been validated. Thus the validation of the surveillance radar model is undertaken by first comparing it with existing and accepted radar simulations such as CARPET (Ref. 28) and Rohan (Ref. 29) when it is possible to find commonality. Obviously, this validation is different from a shipboard evaluation against live data in a very well controlled environment, but it presents some real advantages in terms of cost and this is an important intermediate step before implementing or acquiring systems. However, the next validation step should be with trial data.

The surveillance radar models used in this study allow the generation of measurements, as well as a representation of the tracking performed inside the sensors. As a result, the simulated data are very close to the outputs of the SPS-49 and Sea Giraffe. This represents an original novelty of our simulation environment. Conventional radar simulations such as CARPET are not fully suitable for sensor fusion studies mainly because of this requirement for measurement generation and data processing. CARPET, for example, only gives plots of different parameters of the radar detection aspects.

UNCLASSIFIED

30

The STIR fire-control radar is simulated at the same level of detail, considering the same environmental effects. An existing Seaborne Fire Control Radar (SEFCOR) (Ref. 30) simulation of a pencil-beam monopulse tracking radar is going to be modified and adapted to model the STIR. To complete the representation of the suite of sensors it is required to provide the CASE_ATTII system with an ESM (CANEWS) simulation capability. For example, this could be accomplished by taking advantage of two products developed by Lockheed Canada: "Lockheed Canada Electronic Warfare Environmental Simulator (LEWES)" (Ref. 31) and "LC2000 ESM system" (Ref. 32). The LEWES system provides a scenario generator software capability, while the LC2000 ESM system provides an ESM data processor software capability. The combined software packages can be used to simulate an ESM system. However, this simulation would not be integrated per se into CASE_ATTII; only the ESM output data would be integrated. The Lockheed's software packages would be modified to represent CANEWS capabilities, and to render the ESM simulation compatible with the CASE_ATTII environment.

The baseline performance will be evaluated against the predicted future threat. More precisely, all performance evaluations will be against the AWW mission and threat requirements, including maneuvering targets and if possible ECM conditions, which have recently been specified for the Canadian Navy. The environmental scenarios to be used will be those developed by DREV for the NATO Anti Air Warfare System (NAAWS) *program*. An appropriate methodology is currently being defined for MSDF algorithm performance evaluation. This is a complex issue because of the diversity of aspects involved. The method to be used needs to handle the ambiguities that arise in modern multiple sensor, multiple target tracking problems.

On one hand, evaluating the performance of tracking algorithms is straightforward in a clutter-free environment of few, widely spaced targets. In this sparse environment, a track is consistently updated with measurements from the same target. The track, or state estimate, is then assigned and compared with the true, non ambiguous target state. On the other hand, performance evaluation is complex in a dense multiple target environment with clutter, false alarms and unresolved closely spaced objects, because of ambiguities that create confusion about which target goes with a track (Ref. 33). This is a fundamental problem in evaluating multiple target tracking (MTT) algorithms that is not encountered in performance evaluations with only a single object. In this case, a track is not consistently updated with measurements from the same target because some sensor observations of

UNCLASSIFIED

31

other targets, clutter, or false alarms will be incorrectly associated with the track and some sensor observations associated with the track will be unresolved closely spaced objects. Hence, the source of the measurements in a track will not provide a clear indication of a single target, thus confusing which track is to be compared with the true state of a target. Furthermore, in a dense target environment, there may be:

- missed tracks: targets without tracks
- false tracks:
 - redundant tracks: more than one track for one target
 - spurious tracks: tracks for no target whatsoever
 - lost tracks: once valid tracks that become spurious

The performance evaluation methodology must accommodate all tracks, those for targets of interest and those due to background clutter and other objects that are not of interest. The false and missed tracks should be identified and counted in addition to resolving the ambiguities for the valid tracks. Even with only one target of interest, persistent clutter points can create objects in the field of view that may have to be treated as multiple targets by the tracking algorithms. Most of these apparent targets should eventually be identified as stationary objects. However, they can be close to targets of interest and thus require MTT algorithms.

A two-step approach is thus necessary for MTT performance evaluation. One first needs to relate targets to tracks. Then, after tracks and truth have been associated, one can evaluate performance criteria for the two main functions of a MTT algorithm: data association and state estimation. Measures of sensor suite performance such as detection range, firm track range, transition time from first detection to firm track, track maintenance, track purity, false tracks, track accuracy, and credibility of the filter calculated covariance are then employed.

4.2 Advanced Sensors and MSDF Concepts for Performance Improvement

The Canadian Navy is planning to upgrade the CPF sensor suite. However, the development and/or acquisition of advanced AWW sensors, although necessary, may not be sufficient for providing the required protection for ships against the anticipated future threats. The simple interfacing of these components is not enough because such independent AWW elements are seldom used in a coordinated manner, which typically

UNCLASSIFIED

32

leads to a confusing and time-late decision environment for the ship's commander. Hence, the effectiveness of the AWW system is not completely determined by the capabilities of the AWW sensor suite alone, but also by the effectiveness of the system integration which must focus on cooperative, synergistic, and efficient utilization of all of the AWW sensors.

In that context, an incremental approach has been chosen to demonstrate how the performance of the CPF sensor suite can be improved using an upgraded sensor suite combined with advanced MSDF concepts. The idea is to compare alternative methods against a common problem and to evaluate the results with respect to the baseline performance. The first step is to allow minor modifications to the existing system such that the current tracking algorithms for each sensor taken individually can be improved with advanced techniques, and sensor data fusion can be used within the CCS. This is accomplished within the CASE_ATTII system. CASE_ATTII allows the possibility of trying all kinds of tracking algorithms as well as assessing the performance of various types of fusion architecture. Any resulting performance improvements with respect to the baseline performance will be quantified.

The second step is to add an Infrared Search and Track (IRST) simulation to the current representation of the CPF sensor suite. The required MSDF techniques and algorithms to support this addition to the sensor suite will be identified and developed. An IRST model (Ref. 26), that was developed during NAAWS, is being modified to take into account recent developments, as well as the need to represent a data processing capability inside the IRST. The performance obtained through MSDF for the modified sensor suite will be evaluated and any resulting improvements will be quantified.

The last step is to further modify the current CPF sensor suite by replacing the STIR and the Sea Giraffe simulations with a Multi-Function Radar (MFR) model, and by upgrading the CANEWS ESM simulation. The MSDF algorithms and techniques required for the integration of this upgraded sensor suite will be identified and developed. The level of simulation required to represent the MFR functions needs to be identified. A starting point may be the model (Ref. 34) developed under NAAWS. The ESM simulation will be modified to account for anticipated CANEWS 2 capabilities. Again, any resulting performance improvements will be quantified.

5.0 CONCLUSION

Given that it is a critical issue for the evolution of naval C², there are multiple ongoing research activities at Defence Research Establishment Valcartier (DREV) on local area Multi-Sensor Data Fusion (MSDF) for naval applications afloat.

A broad spectrum of tools could potentially be used to support MSDF studies. This spectrum ranges from using very simple computer simulations supporting rigorous mathematical analyses to actually testing prototypes during live military exercises. Generally, there are tradeoffs in selecting one approach over the other. It was decided to employ high-fidelity simulations for the MSDF project at DREV. The CASE_ATTI (Concept Analysis and Simulation Environment for Automatic Target Tracking and Identification) system built to support theoretical studies on MSDF was described in this document. It is a highly modular, structured, and flexible simulation environment providing the algorithm-level test and replacement capability required to study and compare the technical feasibility, applicability and performance of advanced, state-of-the-art MSDF techniques.

Algorithm-level testbeds such as CASE_ATTI are becoming necessary to efficiently study MSDF concepts that could be used to fulfill the Canadian Forces requirements in the selection of integrated surveillance and tracking systems, and in the optimization of their operation for better performance. In this document we discussed the use of the CASE_ATTI system to support the development of MSDF concepts that could apply to the current CPF sensor suite, as well as its anticipated upgrades, in order to improve its AWW performance against the predicted future threat. The establishment of the CPF sensor suite baseline performance along with an incremental approach to demonstrate how this performance can be improved using an upgraded sensor suite combined with advanced MSDF concepts were discussed.

The tool sets and trial data sets for supporting MSDF R&D are, like the MSDF process and its algorithms, only beginning to mature. Modern designs of true testbeds permitting flexible algorithm-level test-and-replace capability for scientific experimentation are beginning to appear and are, at least, usable within certain subsets of the Canadian MSDF community. These testbed environments offer not only an economical basis for the testing of MSDF techniques and algorithms, but, more importantly, a means to achieve

UNCLASSIFIED

34

optimality or at least properly satisfying performance requirements of candidate methods under test.

Motivated in part by the need for continuing maturation of the MSDF process and the amalgam of techniques employed, and in part by expected reductions in the defence research budget, the data fusion community should consider strategies for the sharing of resources for R&D. Plans to share demonstrator testbeds on a broader basis are indeed beginning to appear. The possibility to use CASE_ATTII to support the research performed at DREO for the computation of the tactical picture in the context of the North Warning System (NWS) is currently being seriously studied. In the coming era of very tight defense research budgets, algorithm-level testbeds should enter a national inventory. For example, CASE_ATTII, as an available product, could also play an important role in the third phase of the D6195/ASCACT (Advanced Shipboard Command and Control Technology) project, to become a component of a more global C² testbed.

UNCLASSIFIED

35

6.0 REFERENCES

- [1] Roy, J.M.J., Bossé, É. and Des Groseilliers, L., "State of the Art in Local Area Sensor Data Fusion for Naval Command and Control Afloat," DREV R-9410, May 1995, UNCLASSIFIED
- [2] Llinas, J., "Assessing the Performance of Multisensor Fusion Systems", SPIE, Vol. 1611, "Sensor Fusion IV", 1991.
- [3] Naval Ship Weapon Systems Engineering Station, "AN/SAR-8 Developmental Test-II / Final Report (U)", NSWSES Test Report - 9120, Code 4L00, Port Hueneme, CA, 3 October 1991.
- [4] Caron, L., "A CPF Combat System Performance Monitoring and Analysis System", Maritime Engineering Journal, February, 1994.
- [5] Thomson-CSF Systems Canada, "Sensor Data Fusion Technology - Task I Report", Defence Industrial Research Program, Agreement No.: 22071EV03, Thomson Systems File No.: G0574C, Submission Date: September 1992, UNCLASSIFIED. (DREV Scientific Authority: J.M.J. Roy)
- [6] Thomson-CSF Systems Canada, "Sensor Data Fusion Technology - Task II Report", Defence Industrial Research Program, Agreement No.: 22071EV03, Thomson Systems File No.: G0574C, Submission Date: September 1992, UNCLASSIFIED. (DREV Scientific Authority: J.M.J. Roy)
- [7] Thomson-CSF Systems Canada, "Sensor Data Fusion Technology - Task III Report", Defence Industrial Research Program, Agreement No.: 22071EV03, Thomson Systems File No.: G0574C, Submission Date: September 1992, UNCLASSIFIED. (DREV Scientific Authority: J.M.J. Roy)
- [8] Alford, M. and Wynne, D., "A Multitarget, Multisensor Tracking Simulation for Comparison of Fusion Algorithm Performance", Proceedings of the 3rd National Symposium on Sensor Fusion, Orlando, FL, April, 1990.

UNCLASSIFIED

36

- [9] Konle, W. and Maier-Herburger, H., "Development Strategy for Multi-Sensor Data Fusion Systems by Using an Integrated Testbed Approach", NATO AC/243 (Panel 3) and (Panel 4) Symposium on Multisensors and Sensor Data Fusion, Brussels, Belgium, 8-11 November 1993.
- [10] Paramax Systems Canada, "Implementation of Sensor-Level Hard Fusion for CSTSF Sensors", Defence Industrial Research Program Proposal, 18 November, 1992.
- [11] Paramax Systems Canada, "Implementation of Sensor-Level Hard Fusion for CSTSF Sensors: System Performance Specification", Preliminary, Defence Industrial Research Program, Agreement No.: 22072EV07, Financial Code: 1430AA-20JA-10226, Paramax DM No.: 112000012, June 11, 1993, UNCLASSIFIED. (DREV Scientific Authority: J.M.J. Roy)
- [12] Boily, E., "Performance Evaluation of a Multisensor Data Fusion Implementation: A Progress Report", SPIE Proceedings, Vol. 2235, "Signal and Data Processing of Small Targets 1994", 5-7 April 1994. (DREV Scientific Authority: J.M.J. Roy)
- [13] Bégin, F., Kamoun, S. and Valin, P., "Implementation of AAW Sensors Fusion on the Canadian Patrol Frigate", SPIE Proceedings, Vol. 2235, "Signal and Data Processing of Small Targets 1994", 5-7 April 1994. (DREV Scientific Authority: J.M.J. Roy)
- [14] Nedvidek, M., de Kok, L. and Farooq, M., "A Multi-Sensor Multi-Target Simulation Environment for the Study of Tracking Multiple Targets in a Cluttered Environment", EE Tech. Report No. 92/5, Department of Electrical and Computer Engineering, Royal Military College of Canada, Kingston, Ontario, September 1992. (DREV Scientific Authority: J.M.J. Roy)
- [15] Roy, J., Nedvidek, M., Johnson, R., de Kok, L. and Farooq, M., "A Prototype for Sensor Data Fusion", NATO AC/243 (Panel 3) and (Panel 4) Symposium on Multisensors and Sensor Data Fusion, Brussels, Belgium, 8-11 November 1993.
- [16] Johnson, R., Nedvidek, M., de Kok, L. and Farooq, M., "CASE-ATTI Software Description", EE Tech. Report No. 93/7, Department of Electrical and Computer

UNCLASSIFIED

37

- Engineering, Royal Military College of Canada, Kingston, Ontario, September 1993.
(DREV Scientific Authority: J.M.J. Roy)
- [17] Johnson, R. and Farooq, M., "CASE-ATTI Multiple-Sensor Multiple-Target Tracking Module", EE Tech. Report No. 94/3, Department of Electrical and Computer Engineering, Royal Military College of Canada, Kingston, Ontario, January 1994. (DREV Scientific Authority: J.M.J. Roy)
- [18] de Kok, L. and Farooq, M., "Graphical Interfaces of CASE-ATTI", EE Tech. Report No. 94/1, Department of Electrical and Computer Engineering, Royal Military College of Canada, Kingston, Ontario, January 1994. (DREV Scientific Authority: J.M.J. Roy)
- [19] Paramax Systems Canada, "Investigations on Target Tracking and Classification Using Multiple Sensor Data Fusion: Task VII - Feasibility Analysis for Implementation of the Selected Multiple Sensor Data Fusion Functions", Technical Report / Rev.-, Paramax-SSC Contract Number: W7701-0-3203/01-XSK, 15 June 1992, UNCLASSIFIED. (DREV Scientific Authority: J.M.J. Roy)
- [20] Roy, J.M.J., "Multisensor Tracking and Classification of Maneuvering Targets in a Cluttered Environment: Top Level Modeling and Simulation Propositions", DREV M-3029/90, May 1990, UNCLASSIFIED
- [21] Roy, J.M.J., "A Simulation Environment for the Study of Advanced Multiple Target Tracking Concepts", DREV R-4729/93, October 1993, UNCLASSIFIED
- [22] Beaupré, J.C.F. and Farooq, M., "A Heuristic Multiple Target Tracker", EE Tech. Report No. 92/6, Department of Electrical and Computer Engineering, Royal Military College of Canada, Kingston, Ontario, September 1992, UNCLASSIFIED. (DREV Scientific Authority: J.M.J. Roy)
- [23] Beaupré, J.C.F., Farooq, M. and Roy, J.M.J., "A Heuristic Multiple Target Tracker", 4th Symposium/Workshop on Applications of Expert Systems in DND, RMCC Kingston, Ont., 23-24 April 1992, UNCLASSIFIED.
- [24] Stroustrup, B. "The C++ Programming Language," Addison-Wesley Publishing Company, Reading, Mass., 1991.

UNCLASSIFIED

38

- [25] Bossé, É., Dion, D. and Roy, J.M.J., "A Shipborne Surveillance Radar Model for Data Fusion Studies", DREV R-9429, UNCLASSIFIED
- [26] Roy, S., Picard, G. and Savoie, F., "Top-Level Model of an IRST-Type Sensor," DREV R-4579/89, December 1989, UNCLASSIFIED
- [27] Roy, J.M.J., "Overview of Multisensor Tracking and Classification of Maneuvering Targets in a Cluttered Environment," DREV M-3018/90, April 1990, UNCLASSIFIED
- [28] Huizing, A.G., Theil, A., "Computer-Aided Radar Performance Evaluation Tool: CARPET", User's Manual, Artech House, 1993.
- [29] Rohan, P., "Surveillance Radar Prediction", Peter Peregrinus Ltd, 1983.
- [30] Hitech Canada Limited, "Seaborne Fire Control Radar Simulation", Contract No. OSD80-00062, Final Report, Oct. 1981.
- [31] Lockheed Canada Inc., "Lockheed Canada Electronic Warfare Environmental Simulator User Manual", Document No.: 1005017, Issue No. 1, 5 November 1993.
- [32] Lockheed Canada Inc., "Product Description of the LC2000 ESM System", Document No.: MVJ-OTT-123, Issue No. 04, 18 June 1993.
- [33] Drummond, O.E., Fridling, B.E., "Ambiguities in Evaluating Performance of Multiple Target Tracking Algorithms", Proceedings of the SPIE, Vol. 1698, "Signal and Data Processing of Small Targets 1992", 1992.
- [34] Moore, J.R., "Sensor track model for NATO AAW Multifunction Radar Options", Technical Report Tasks 3-1-14/19, JHU/APL, June 1988.
- [35] Bruder, S., Lim, S., Little, S. and Farooq, M., "A Study of the Single Target in Clutter Problem and Phase One of a Modular Multi-Sensor Multi-Target Simulation Environment", EE Tech. Report No. 91/12, Department of Electrical and Computer Engineering, Royal Military College of Canada, Kingston, Ontario, April 1991, UNCLASSIFIED. (DREV Scientific Authority: J.M.J. Roy)

UNCLASSIFIED

39

INTERNAL DISTRIBUTION

DREV - R - 9411

1 - Deputy Chief
1 - Director Command and Control Division
1 - Director Electro-optics Division
6 - Document Library
1 - J.M.J. Roy (author)
1 - É. Bossé (author)
1 - D. Dion (author)
1 - G. Picard
1 - G. Otis
1 - R. Carling
1 - B. Chalmers
1 - J. Berger
1 - R. Charpentier
1 - D. Demers
1 - P. Labbé
1 - C. Helleur
1 - D. Gouin
1 - M. Gauvin
1 - V. Pille
1 - J.-C. Labbé
1 - J. Boulter
1 - L. Sévigny
1 - P. Chevrette
1 - R. Philippe
1 - P. Twardawa
1 - C. Carrier
1 - M. Lauzon

UNCLASSIFIED
40

EXTERNAL DISTRIBUTION

DREV - R - 9411

2 - DSIS
1 - CRAD
1 - MARCOM N6
1 - DMCS
1 - DMCS - 2
1 - DMCS - 2 - 4
1 - DMCS - 2 - 4 - 4
1 - DMCS - 4
1 - DMCS - 4 - 2
1 - DMCS - 4 - 3
1 - DMCS - 4 - 4
1 - DMCS - 4 - 4 - 3
1 - DMCS - 4 - 5 - 3
1 - DMCS - 4 - 5 - 4
1 - DMCS - 7
1 - DMCS - 7 - 2
1 - DMCS - 7 - 3
1 - DMCS - 7 - 3 - 2
1 - DMCS - 7 - 7
1 - DMCS - 7 - 7 - 2
1 - DMCS - 7 - 8
1 - DMFD
1 - DMOR
1 - DNR
1 - DNR - 4
1 - DNR - 4 - 4
1 - DNR - 4 - 6
1 - DNR - 8
1 - DRDCS

UNCLASSIFIED

41

EXTERNAL DISTRIBUTION (cont'd)

DREV - R - 9411

- 1 - DRDCS - 4
- 1 - DRDCS - 5
- 1 - DRDM
- 1 - DRDM - 6
- 1 - DRDM - 11
- 1 - DCIEM;
Attn: R. Angus
- 1 - DREA;
Attn: A. Ashley
- 1 - DREA;
Attn: M. McIntyre
- 1 - DREO;
Attn: C. Malone
- 1 - DREO;
Attn: D. Liang
- 1 - DREO;
Attn: P. Yansouni
- 1 - DREO;
Attn: M. Blanchette
- 1 - DREO;
Attn: D. Dyck
- 1 - DREO;
Attn: P. Lee
- 1 - DREO;
Attn: B. Ford
- 1 - DREO;
Attn: R. Turner
- 1 - DREO;
Attn: B. Wong
- 1 - DREO;
Attn: H. Leung
- 1 - DREO;
Attn: J. Loo

UNCLASSIFIED

42

EXTERNAL DISTRIBUTION (cont'd)

DREV - R - 9411

- 1 - Department of Electrical and Computer Engineering
Royal Military College of Canada
Kingston, Ontario
K7K 5L0
Attn: M. Farooq
- 1 - PMO Aurora
- 1 - PMO Aurora;
Attn: Maj G.L.J. Gélinas
- 1 - PMO Aurora;
Attn: Capt J.Y.J.R. Létourneau
- 1 - PMO Aurora;
Attn: Capt J.J.D. Lavoie
- 1 - PMO CPF
- 1 - PMO NWS
- 3 - Paramax Systems Canada
6111, avenue Royalmount
Montréal, Québec
H4P 1K6
Attn: R.A. Simon
P. Hamilton
E. Shahbazian
- 1 - Thomson-CSF Systems Canada Inc.
18 Auriga Drive
Ottawa, Ontario
K2E 7T9
Attn: K. Bowring
- 1 - MacDonald Dettwiler
13800 Commerce Parkway
Richmond, British Columbia
V6V 2J3
Attn: B. Sharpe
- 1 - SPAR Aerospace Ltd.
9445 Airport Road
Brampton, Ontario
L6S 4J3
Attn: L.G. Gregoris

UNCLASSIFIED

43

EXTERNAL DISTRIBUTION (cont'd)

DREV - R - 9411

- 4 - Lockheed Canada Inc.
1 Iber Road
Stittsville, Ontario
K2S 1E6
Attn: A. Sowards
W. Cornish
K. Doucet
R. Cooper
- 1 - Software Kinetics Ltd.
65 Iber Road
Stittsville, Ontario
K2S 1E7
Attn: J. Bell
- 1 - Altek Systems Inc.
1643 Country Walk Drive
Orleans, Ontario
K1C 8E2
Attn: J.R. Altoft
- 1 - Defence Research Agency (DRA)
Naval Communications Division
Portsdown, Portsmouth
Hampshire
United Kingdom
PO6 4AA
Attn: C. Gibson
- 1 - NRAD
Naval C2 and Ocean Surveillance Center
RDT&E Division
San Diego, CA
U.S.A.
92152-5000
Attn: M.B. Vineberg
- 1 - Canadian Forces Command and Staff College
Toronto
Attn: DComdt
- 1 - Canadian Forces School of Aerospace Studies
CFB Winnipeg
Westwin, Manitoba
R3J 0T0
Attn: DComdt

UNCLASSIFIED

44

EXTERNAL DISTRIBUTION (cont'd)

DREV - R - 9411

- 2 - CF Maritime Warfare School
CFB Halifax
Halifax, Nova Scotia
Attn: LCDR Connor
LCDR Harrison
- 2 - Department of Electrical Engineering
Laval University
Ste-Foy, Québec
G1K 7P4
Attn: D. Grenier
M. Lecours
- 1 - Communication Research Laboratory
McMaster University
1280 Main Street West
Hamilton, Ontario
L8S 4L7
Attn: J. Litva
- 1 - C. White
STP-9 Chairman/Australian National Leader
Head, Command System Support Group
DSTO C3 Research Center
Information Technology division
Department of Defence
Level 1, Building B,
Hewlett Packard Building
Fern Hill Park
Bruce
ACT 2617
Australia
- 1 - G. Prentice
STP-9 New Zealand National Leader
Defence Scientific Establishment
Auckland Naval Base
Devonport
Auckland
New Zealand

UNCLASSIFIED

45

EXTERNAL DISTRIBUTION (cont'd)

DREV - R - 9411

- 1 - R. N. Piercey
Head, CBC2
STP-9 British National Leader
Defence Research Agency
Fort Halstead
Sevenoaks
Kent TN14 7BP
United Kingdom
- 1 - A. F. Snyder
STP-9 US National Leader
Rome Laboratory/C3A
525 Brooks road
Griffiss Air Force Base
New York 13441-4505
USA
- 1 - J. Dussault
Rome Laboratory/C3AB
525 Brooks Road
Griffiss Air Force Base
New York 13441-4505
USA
- 1 - D. Klose
CECOM - Communications Electronic Command
C&C Systems Integration Directorate
Upper Echelon Command and Control Division
ATTN. AMSEL-RD-C3-CU
Forth Monmouth
New Jersey 07703-5203
USA
- 1 - R. Wasilausky
Naval Command, Control and Ocean
Surveillance Center (NRaD),
Code 4040, San Diego,
California 92152-5057
USA

UNCLASSIFIED
SECURITY CLASSIFICATION OF FORM
(Highest classification of Title, Abstract, Keywords)

DOCUMENT CONTROL DATA

| | | |
|---|--|--|
| 1. ORIGINATOR (name and address) DREV 2459 Blvd Pie XI North P.O. Box 8800 Courcellette, Qc GOA 1R0 | 2. SECURITY CLASSIFICATION (Including special warning terms if applicable) UNCLASSIFIED | |
| 3. TITLE (Its classification should be indicated by the appropriate abbreviation (S,C,R or U)) "CASE_ATT1: AN ALGORITHM-LEVEL TESTBED FOR MULTI-SENSOR DATA FUSION" (U) | | |
| 4. AUTHORS (Last name, first name, middle initial. If military, show rank, e.g. Doe, Maj. John E.) ROY, Jean, BOSSÉ, Éloi and DION, Denis | | |
| 5. DATE OF PUBLICATION (month and year) May 1995 | 6a. NO. OF PAGES 45 | 6b. NO. OF REFERENCES 35 |
| 7. DESCRIPTIVE NOTES (the category of the document, e.g. technical report, technical note or memorandum. Give the inclusive dates when a specific reporting period is covered.) Report | | |
| 8. SPONSORING ACTIVITY (name and address) N/A | | |
| 9a. PROJECT OR GRANT NO. (Please specify whether project or grant) 0112C14A (Sensor Data Fusion) | 9b. CONTRACT NO. N/A | |
| 10a. ORIGINATOR'S DOCUMENT NUMBER DREV-R/9411 | 10b. OTHER DOCUMENT NOS. N/A | |
| 11. DOCUMENT AVAILABILITY (any limitations on further dissemination of the document, other than those imposed by security classification) <input checked="" type="checkbox"/> Unlimited distribution <input type="checkbox"/> Contractors in approved countries (specify) <input type="checkbox"/> Canadian contractors (with need-to-know) <input type="checkbox"/> Government (with need-to-know) <input type="checkbox"/> Defence departments <input type="checkbox"/> Other (please specify) : | | |
| 12. DOCUMENT ANNOUNCEMENT (any limitation to the bibliographic announcement of this document. This will normally correspond to the Document Availability (11). However, where further distribution (beyond the audience specified in 11) is possible, a wider announcement audience may be selected.) | | |

UNCLASSIFIED
SECURITY CLASSIFICATION OF FORM

13. **ABSTRACT** (a brief and factual summary of the document. It may also appear elsewhere in the body of the document itself. It is highly desirable that the abstract of classified documents be unclassified. Each paragraph of the abstract shall begin with an indication of the security classification of the information in the paragraph (unless the document itself is unclassified) represented as (S), (C), (R), or (U). It is not necessary to include here abstracts in both official languages unless the text is bilingual).

A key element in the anticipated information management problem on a naval platform is the ability to combine or fuse data, not only as a volume-reducing strategy, but also as a means to exploit the unique combinations of data that may be available. In this regard, the Command and Control Division at DREV is involved in multiple R&D activities in the field of local area Multi-Sensor Data Fusion (MSDF) for naval command and control afloat. Many different approaches to MSDF have been investigated and developed recently in response to the ever-increasing importance of the subject. However, at this stage of development, no standard approach is generally accepted for all applications. A wide variety of techniques have been proposed for many diverse applications, and the system designer must choose the techniques that are best suited to a specific problem. One of the best tools to help the designer with such a choice is a computer simulation for proof-of-concept purposes. This document presents an overview of the CASE_ATT1 (Concept Analysis and Simulation Environment for Automatic Target Tracking and Identification) algorithm-level simulation testbed that has been developed by DREV to support the theoretical work. CASE_ATT1 provides the highly modular, structured and flexible hardware/software environment necessary to study and compare various advanced MSDF concepts and schemes in order to demonstrate their applicability, feasibility and performance. The document also discusses the use of CASE_ATT1 to support an ongoing MSDF performance evaluation study in the context of the Canadian Patrol Frigate.

14. **KEYWORDS, DESCRIPTORS or IDENTIFIERS** (technically meaningful terms or short phrases that characterize a document and could be helpful in cataloguing the document. They should be selected so that no security classification is required. Identifiers, such as equipment model designation, trade name, military project code name, geographic location may also be included. If possible keywords should be selected from a published thesaurus. e.g. Thesaurus of Engineering and Scientific Terms (TEST) and that thesaurus-identified. If it is not possible to select indexing terms which are Unclassified, the classification of each should be indicated as with the title.)

Data Fusion
Multi-Sensor Data Fusion
Simulation
Simulation Environment
Testbed
Canadian Patrol Frigate
Performance Evaluation
Target Tracking
Target Identification

UNCLASSIFIED
SECURITY CLASSIFICATION OF FORM

Requests for documents
should be sent to:

DIRECTOR SCIENTIFIC INFORMATION SERVICES
Dept. of National Defence
Ottawa, Ontario
K1A 0K2
Tel: (613) 995-2971
Fax: (613) 996-0392

#151678

| | | |
|-----------------------------------|----------------------|--|
| NO. OF COPIES NOMBRE DE COPIES | COPY NO. COPIE N° | INFORMATION SCIENTIST'S INITIALS INITIALES DE L'AGENT D'INFORMATION SCIENTIFIQUE |
| 1 | 1 | JC |
| AQUISITION ROUTE FOURNI PAR | DREU | |
| DATE | 17 May 95 | |
| DSIS ACCESSION NO. NUMÉRO DSIS | | |

DND 1168 (6-87)



**PLEASE RETURN THIS DOCUMENT
TO THE FOLLOWING ADDRESS:**

DIRECTOR
SCIENTIFIC INFORMATION SERVICES
NATIONAL DEFENCE
HEADQUARTERS
OTTAWA, ONT. - CANADA K1A 0K2

**PRIÈRE DE RETOURNER CE DOCUMENT
À L'ADRESSE SUIVANTE:**

DIRECTEUR
SERVICES D'INFORMATION SCIENTIFIQUES
QUARTIER GÉNÉRAL
DE LA DÉFENSE NATIONALE
OTTAWA, ONT. - CANADA K1A 0K2

DIRECTEUR - SERVICES D'INFORMATION SCIENTIFIQUE
Ministère de la Défense nationale
Ottawa, Ontario
K1A 0K2

Téléphone: (613) 995-2971
Télex: (613) 996-0392