

AquaForce Variable Speed Package System

Table of Contents

1 Introduction and Safety.....	3
1.1 Introduction.....	3
1.2 Safety.....	3
1.2.1 Safety terminology and symbols.....	3
1.2.2 Protecting the environment.....	4
1.3 User safety.....	4
1.3.1 Wash the skin and eyes.....	5
2 Transportation and Storage.....	7
2.1 Examine the delivery.....	7
2.1.1 Examine the package.....	7
2.1.2 Examine the unit.....	7
2.2 Transportation guidelines.....	7
2.2.1 Lifting methods.....	7
2.3 Storage guidelines.....	7
2.3.1 Long term storage.....	8
3 Product Description.....	10
3.1 General description.....	10
3.1.1 Operational limits.....	10
3.2 Nameplate information.....	10
4 Installation.....	12
4.1 Reference manuals.....	12
4.2 Field connections.....	12
4.3 ground (earth) connections.....	12
4.4 Pump package location guidelines.....	13
4.5 Foundation requirements.....	13
4.6 Level the base on a concrete foundation	14
4.7 Grout the baseplate.....	14
4.8 Piping checklist.....	14
5 Commissioning, Startup, Operation, and Shutdown.....	16
5.1 Preparation for startup.....	16
5.1.1 Prestartup checklist.....	16
5.1.2 Final installation checks.....	17
5.1.3 Final adjustments.....	17
5.2 Pump station startup.....	17
5.2.1 Confirm the job site voltage.....	17
5.2.2 Connect the storage tank.....	18
5.2.3 Optional water level control relay.....	18
5.2.4 Check for available suction water.....	20
5.2.5 Start the package.....	20
5.2.6 Check the pump rotation.....	20
5.2.7 Set the system operating pressure.....	20
5.2.8 Enter the setup menu.....	20
5.2.9 Test the package.....	21
6 Maintenance.....	22
6.1 Precautions.....	22

6.2 Monthly maintenance.....	22
7 Troubleshooting.....	24
7.1 Pump station troubleshooting.....	24
7.1.1 The pump station does not power up.....	24
7.1.2 The station powers up, but the pumps do not run.....	24
7.1.3 The pumps run but do not build desired pressure.....	25
7.1.4 The pump station experiences excessive vibration.....	26
7.1.5 The pump station does not shut down and no water is used.....	26
7.1.6 The pump station cycles or hunts erratically.....	26
8 Technical Reference.....	28
8.1 Pump station numbering system.....	28
8.1.1 Pump station with e-SV pumps.....	28
8.1.2 Pump station with NPE pumps.....	29
8.1.3 Pump station with SSH pumps.....	30
9 Appendix.....	33
9.1 Installation drawings.....	33
10 Product warranty.....	39

1 Introduction and Safety

1.1 Introduction

Purpose of this manual

The purpose of this manual is to provide necessary information for:

- Installation
- Operation
- Maintenance



CAUTION:

Read this manual carefully before installing and using the product. Improper use of the product can cause personal injury and damage to property, and may void the warranty.

NOTICE:

Save this manual for future reference, and keep it readily available at the location of the unit.

1.2 Safety



WARNING:

- The operator must be aware of safety precautions to prevent physical injury.
- Operating, installing, or maintaining the unit in any way that is not covered in this manual could cause death, serious personal injury, or damage to the equipment. This includes any modification to the equipment or use of parts not provided by Xylem. If there is a question regarding the intended use of the equipment, please contact a Xylem representative before proceeding.
- Do not change the service application without the approval of an authorized Xylem representative.



CAUTION:

You must observe the instructions contained in this manual. Failure to do so could result in physical injury, damage, or delays.

1.2.1 Safety terminology and symbols



About safety messages

It is extremely important that you read, understand, and follow the safety messages and regulations carefully before handling the product. They are published to help prevent these hazards:

- Personal accidents and health problems
- Damage to the product and its surroundings
- Product malfunction



Hazard levels

Hazard level	Indication
 DANGER:	A hazardous situation which, if not avoided, will result in death or serious injury

Hazard level	Indication
 WARNING:	A hazardous situation which, if not avoided, could result in death or serious injury
 CAUTION:	A hazardous situation which, if not avoided, could result in minor or moderate injury
NOTICE:	Notices are used when there is a risk of equipment damage or decreased performance, but not personal injury.

Special symbols

Some hazard categories have specific symbols, as shown in the following table.

Electrical hazard	Magnetic fields hazard
 Electrical Hazard:	 CAUTION:

1.2.2 Protecting the environment

Emissions and waste disposal

Observe the local regulations and codes regarding:

- Reporting of emissions to the appropriate authorities
- Sorting, recycling and disposal of solid or liquid waste
- Clean-up of spills

Exceptional sites



CAUTION: Radiation Hazard

Do NOT send the product to Xylem if it has been exposed to nuclear radiation, unless Xylem has been informed and appropriate actions have been agreed upon.

Recycling guidelines

Always follow local laws and regulations regarding recycling.

1.3 User safety

General safety rules

These safety rules apply:

- Always keep the work area clean.
- Pay attention to the risks presented by gas and vapors in the work area.
- Avoid all electrical dangers. Pay attention to the risks of electric shock or arc flash hazards.
- Always bear in mind the risk of drowning, electrical accidents, and burn injuries.

Safety equipment

Use safety equipment according to the company regulations. Use this safety equipment within the work area:

- Hard hat
- Safety goggles, preferably with side shields
- Protective shoes
- Protective gloves
- Gas mask
- Hearing protection
- First-aid kit
- Safety devices

NOTICE:

Never operate a unit unless safety devices are installed. Also see specific information about safety devices in other chapters of this manual.

Electrical connections

Electrical connections must be made by certified electricians in compliance with all international, national, state, and local regulations. For more information about requirements, see sections dealing specifically with electrical connections.

Precautions during work

Observe these safety precautions when you work with the product or are in connection with the product:

- Never work alone.
- Always wear protective clothing and hand protection.
- Stay clear of suspended loads.
- Always lift the product by its lifting device.
- Beware of the risk of a sudden start if the product is used with an automatic level control.
- Beware of the starting jerk, which can be powerful.
- Rinse the components in water after you disassemble the pump.
- Do not exceed the maximum working pressure of the pump.
- Do not open any vent or drain valve or remove any plugs while the system is pressurized. Make sure that the pump is isolated from the system and that pressure is relieved before you disassemble the pump, remove plugs, or disconnect piping.
- Never operate a pump without a properly installed coupling guard.

1.3.1 Wash the skin and eyes

Follow these procedures for chemicals or hazardous fluids that have come into contact with your eyes or your skin:

Condition	Action
Chemicals or hazardous fluids in eyes	<ol style="list-style-type: none"> 1. Hold your eyelids apart forcibly with your fingers. 2. Rinse the eyes with eyewash or running water for at least 15 minutes. 3. Seek medical attention.
Chemicals or hazardous fluids on skin	<ol style="list-style-type: none"> 1. Remove contaminated clothing. 2. Wash the skin with soap and water for at least 1 minute. 3. Seek medical attention, if necessary.

Lockout/Tagout provisions**DANGER:**

Electrical hazard sufficient to kill. Always disconnect and lock out the power before you service the unit.

**WARNING:**

- Always disconnect and lock out power to the driver before you perform any installation or maintenance tasks. Failure to disconnect and lock out driver power will result in serious physical injury.

The main station panel is equipped with a main station disconnect for completely powering down the system. This panel also provides individual circuit breaker service disconnects for each pump. These disconnects are accessible without disengaging the main station disconnect to ensure that operation of the system is not interrupted during individual pump service. In both situations (complete station or individual pump power down), provisions for lockout / tagout capability have been provided.

The main station disconnect has a door interlocking feature that utilizes a handle that allows for padlocking.



The individual circuit breaker disconnects are accessible through an inspection/service window that has an integrated locking tab feature. The use of a lockout scissor clamp is highly recommended to properly lockout any of these individual disconnects.



2 Transportation and Storage

2.1 Examine the delivery

2.1.1 Examine the package

1. Examine the package for damaged or missing items upon delivery.
2. Record any damaged or missing items on the receipt and freight bill.
3. If anything is out of order, then file a claim with the shipping company.
If the product has been picked up at a distributor, make a claim directly to the distributor.

2.1.2 Examine the unit

1. Remove packing materials from the product.
Dispose of all packing materials in accordance with local regulations.
2. To determine whether any parts have been damaged or are missing, examine the product.
3. If applicable, unfasten the product by removing any screws, bolts, or straps.
Use care around nails and straps.
4. If there is any issue, then contact a sales representative.

2.2 Transportation guidelines

2.2.1 Lifting methods



WARNING:

- Assembled units and their components are heavy. Failure to properly lift and support this equipment can result in serious physical injury and/or equipment damage. Lift equipment only at the specifically identified lifting points. Lifting devices such as eyebolts, slings, and spreaders must be rated, selected, and used for the entire load being lifted.
 - Crush hazard. The unit and the components can be heavy. Use proper lifting methods and wear steel-toed shoes at all times.
 - Tip over hazard. Do not use component eyebolts to lift the pump station. The eyebolts are only designed to lift the components to which they are attached.
 - Do not attach sling ropes to the panel stand.
-

2.3 Storage guidelines

Storage location

The product must be stored in a covered and dry location free from heat, dirt, and vibrations.

NOTICE:

Protect the product against humidity, heat sources, and mechanical damage.

NOTICE:

Do not place heavy weights on the packed product.

2.3.1 Storage between use

Observe the following for long-term storage of a pump station.

- Insure system is drained of any water.
- Remove transducers to ensure that they do not freeze.
- System may be top-heavy, brace to keep from tipping.

2.3.1 Long term storage

The following procedure applies to **Boosters and HVAC Packages**.

1. Customer furnished equipment and accessories that are not offered as standard or optional by the factory must be handled in accordance with the respective manufacturer's recommendations.
2. Storage longer than one month is considered long term storage.
3. Pumps should be prepared for storage using the following procedure.

SAFETY

- Select a storage location that will prevent potential hazards to persons allowed access to the storage area.
- Appropriate precautions should be taken to ensure safe on-site receipt and transit.
- Potential energy risk should be minimized. Keep product at ground level and prevent stacking or other unsafe positioning that could result in falling, dropping, and/or tipping.

LOCATION AND TREATMENT

- Indoor Storage
 - Little extra preparation is needed if indoor storage area is dry and clean.
 - Care should be taken to prevent extremes in temperature (below 32°F and above 110°F). Also, keep the pump out of direct sunlight and covered to protect it from dust and dirt.
 - Care should be taken to prevent moisture build-up around the pump, either by allowing proper ventilation or tightly sealing the pump in the cover with a suitable amount of desiccant to ensure dryness.
 - If indoor storage area is humid or dirty, such as an unfinished building, treat the pump as if it were to be stored outdoors.
 - If exposure to condensation is expected, un-painted external steel or cast-iron surfaces should be coated with rust-inhibiting oil such as Cortec's VCI-329.
 - Storage location should also provide minimal exposure to vibration and other damage potentially transmitted from adjacent operating equipment.
 - Product supplied in factory cartons, pallets or similar Xylem packaging should be kept in 'as-shipped' condition where possible.
 - Inspect suction and discharge manifold flange covers.
- Outdoor Storage
 - Pump should be covered to protect it from weather and direct sunlight.
 - All coverings should be properly secured to withstand high wind.
 - Care must be exercised in covering pumps to prevent moisture build-up under the cover. This can be done either by allowing proper ventilation or tight sealing cover with suitable amount of desiccant to ensure dryness.
 - Extreme heat and cold are to be avoided, as rubber parts and seals could age prematurely (below 32°F and above 110°F).
 - Storage area should be inspected weekly, and after storms for damage to protective covers.
 - Inspect suction and discharge manifold flange covers.
- Installed But Not in Service

- Preparation for storage under these conditions is the same as for indoor and outdoor, except the suction and discharge piping will serve as flange covers.
- The suction and discharge valves must be tightly closed and all water removed from the pump and attached piping. The interior of the pump and piping must be thoroughly dried.
- Inspect un-painted external steel or cast-iron surfaces once a month for moisture and replace volatile corrosion inhibitor at that time (see section 1.B.a.v)

EQUIPMENT PROTECTION

- Pumps
 - Every 30 days, the pump and motor shaft should be rotated by hand (10-15 turns) to prevent bearing damage and potential for binding. Be sure shaft comes to rest in different positions.
 - Close-coupled pumps may have minimal access to exposed shaft areas. In those cases, care must be taken to avoid damage to the shaft through use of channel-lock pliers or similar tools.
 - If removal of the coupling guard is required for hand-rotation of the pump and motor shafts, this guarding must be reinstalled prior to removal of lock-out tag-out and start-up.
- Control Panels, VFDs, and Electronics
 - For storing electrical control panels, drives and other electrical items for more than 3 months, insertion of moisture absorbing packets within the enclosure may be necessary. Periodically replace as required. Remove packets prior to equipment start-up.
- Package Enclosures
 - Housing vents and/or openings will be sealed with plastic wrap and waterproof tape.
 - Condensation protection shall be provided in accordance to instructions previously noted.

PREPARATION FOR OPERATION

- Remove all rust inhibitor from exposed machined surfaces using the method described by the supplier.
- Remove all corrosion protection devices or material from package.
- Remove flange covers, tape, and all unnecessary pipe plugs.

3 Product Description

3.1 General description

Description

A pump station is a pre-engineered and fabricated line of packaged booster systems that provides:

- Energy efficiency
- System protection
- Hydraulic capability up to 1600 GPM
- Boost pressures up to 300 PSI

Intended applications



WARNING:

This product can expose you to chemicals including Lead, which is known to the State of California to cause cancer and birth defects or other reproductive harm. For more information go to: www.P65Warnings.ca.gov.

The pump station is intended for these applications:

- High rise buildings
- Industrial plants
- Municipal and rural water districts
- Agriculture / irrigation
- General water pressure boosting

3.1.1 Operational limits

Pressure

This table describes the pressure ratings for a pump station using the pump model shown

Pump system type	Max. discharge pressure
NPE pumps	125 PSI
SSH Pumps	230 PSI
e-SV Pumps	300 PSI

3.2 Nameplate information

Important information for ordering

Every pump station has a nameplate that provides information about the pump station. The pump station nameplate is located on the inside of the control enclosure door.

When ordering spare parts, be prepared to identify the nameplate information when contacting the factory.

- Model
- Size
- Serial number
- Item numbers of the required parts.

Model Number	
Serial Number	
Station Voltage	
System FLA	
SCCR	
Largest Motor HP	
Station Flow	
Pump Boost	
Date Code	
 Let's Solve Water	Applied Water Solutions Dallas, Texas, U.S.A Customer Service 1.800.786.7480

Nameplate field	Explanation
Model number	The manufacturer's number to indicate the particular type of product which has been acquired.
Serial number	A set of characters that uniquely identifies a single unit and can be used for traceability and warranty purposes.
Station voltage	The rated voltage at which the station has been designed for. Should match the application site supply voltage.
System FLA	The full-load-amperage at which the station can operate.
SCCR	"Short-Circuit Current rating". Represents the maximum level of short-circuit current that a component or assembly can withstand.
Largest motor HP	The rated HP for the largest pump in the system.
Station flow	The designed duty point, in GPM, LPH, etc.
Pump boost	The difference between the input side of the pump station and the output side of the pump station.
Date code	Marking of products to indicate their date of manufacture.

4 Installation

4.1 Reference manuals

Additional installation information

For information on installing controllers, use the following IOM:

- Technologic = S14367 – constant speed systems
- TechnoForce Pump Controller = 10-001-265 – variable speed systems

4.2 Field connections

Diagrams

Actual equipment manufacturers/models installed are system specific. Refer to specific manufacturer Installation, Operation, and Maintenance manuals for details unique to each component. The pump instruction manual is supplied with the system.

Review the wiring diagrams and dimensional drawings before you install and operate the unit.

Electrical precautions



WARNING:

Electrical shock hazard. The electrical supply must match the control panel nameplate specification. Incorrect voltage can cause a fire, which damages the electrical components and voids the warranty. Failure to follow these instructions could result in serious personal injury or death, or property damage.

NOTICE:

Electrical connections must be made by certified electricians in compliance with all international, national, state, and local rules.

Fastening



WARNING:

- Only use fasteners of the proper size and material.
 - Replace all corroded fasteners.
 - Make sure that all fasteners are properly tightened and that there are no missing fasteners.
-

4.3 ground (earth) connections



WARNING:

Electrical shock hazard. Conduit grounds are not adequate. You must attach a separate ground (earth) wire to the ground (earth) lug provided in the enclosure in order to avoid potential safety hazards. Failure to follow these instructions can result in serious personal injury, death, or property damage.

A grounding terminal is provided for a dedicated ground (earth) wire connection. You must follow all provisions of the National Electrical Code and local codes.

4.4 Pump package location guidelines



WARNING:

Assembled units and their components are heavy. Failure to properly lift and support this equipment can result in serious physical injury and/or equipment damage. Lift equipment only at the specifically identified lifting points. Lifting devices such as eyebolts, slings, and spreaders must be rated, selected, and used for the entire load being lifted.

Guideline	Explanation/comment
Make sure that the space around the pump package is sufficient.	This facilitates ventilation, inspection, maintenance, and service.
If you require lifting equipment such as a hoist or tackle, make sure that there is enough space above the pump package.	This makes it easier to properly use the lifting equipment and safely remove and relocate the components to a safe location.
Use traditional lifting equipment (safety belt, sling, or chain) to secure assembly. Corner holes in base have been provided for installation of an approved lifting eyebolt and nuts (not furnished with package).	Prevention against overturning the package
Protect the unit from weather and water damage due to rain, flooding, and freezing temperatures.	This is applicable if nothing else is specified.
Do not install and operate the equipment in closed systems unless the system is constructed with properly-sized safety and control devices.	Acceptable devices: <ul style="list-style-type: none"> • Pressure relief valves • Compression tanks • Pressure controls • Temperature controls • Flow controls If the system does not include these devices, consult the engineer or architect in charge before you operate the pump.
Take into consideration the occurrence of abnormal noise and vibration.	The best pump location for noise and vibration absorption is on a concrete floor with subsoil underneath.

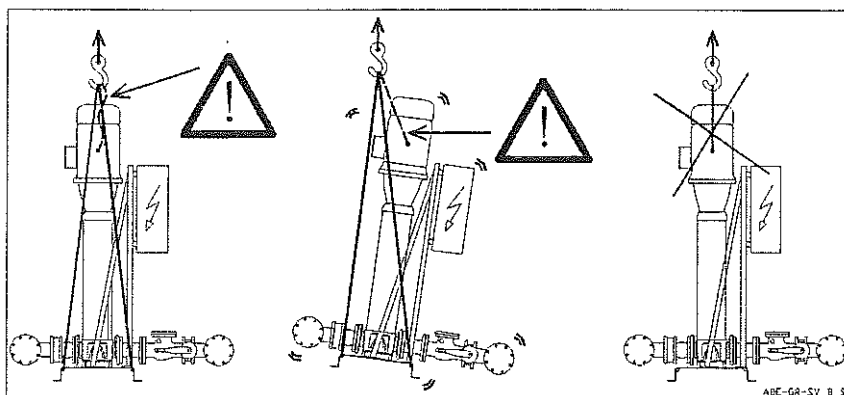

Figure 1: Rigging examples

4.5 Foundation requirements



WARNING:

Electrical shock hazard. An electrical conduit installed below the surface may require a corrosion-resistant protective coating in order to prevent conduit corrosion and electrical shock. Failure to follow these instructions can result in serious personal injury, death, or property damage.

Requirements

- The foundation must be able to absorb any type of vibration and form a permanent, rigid support for the unit.
- The foundation must weigh at least 2-1/2 times the weight of the pump unit.
- Provide a flat, substantial concrete foundation in order to prevent strain and distortion when you tighten the foundation bolts.
- Sleeve-type and J-type foundation bolts are most commonly used. Both designs allow movement for the final bolt adjustment.
- Tie the concrete pad in with the finished floor.

4.6 Level the base on a concrete foundation

1. Place the pump package on its concrete foundation.
2. Place 1.00 in. (25.40 mm) thick steel shims or wedges on both sides of each anchor bolt in order to support the pump package.

Make sure that you also place the shims or wedges midway between the bolts.

This also provides a means of leveling the base.

4.7 Grout the baseplate

Required equipment:

- Cleaners: Do not use an oil-based cleaner because the grout will not bond to it. See the instructions provided by the grout manufacturer.
 - Grout: Non-shrink grout is required.
1. Clean all the areas of the baseplate that will come into contact with the grout.
 2. Build a dam around the foundation.
 3. Thoroughly wet the foundation that will come into contact with the grout.
 4. Pour grout into the baseplate up to top of the base rails.
To hold wedges or shims in place, allow the grout to flow around them.
Follow grout manufacturer's instructions for removing air pockets from grout during pour.
 5. Allow the grout to set.
The grout needs to set for at least 48 hours. Follow any additional instructions from the grout manufacturer.
 6. Tighten the foundation bolts.

4.8 Piping checklist



WARNING:

- The heating of water and other fluids causes volumetric expansion. The associated forces can cause the failure of system components and the release of high-temperature fluids. In order to prevent this, install properly sized and located pressure-relief valves. Failure to follow these instructions can result in serious personal injury or death, or property damage.
- Avoid serious personal injury and property damage. Make sure that the flange bolts are adequately torqued.

NOTICE:

Never force piping to make a connection with a pump.

Check	Explanation/comment	Checked
Check that the suction and discharge pipes are supported independently by use of pipe hangers near the pump station.	This eliminates pipe strain on the pump station.	
Check that there is a strong, rigid support for the suction and discharge lines.	As a rule, ordinary wire or band hangers are not adequate to maintain proper alignment.	
Check that the suction or discharge lines are not forced into position.	Component failure will result if suction or discharge lines are forced into position.	
Check that fittings for absorbing expansion are installed in the system when considerable temperature changes are expected.	This helps to avoid strain on the pump.	
Check that you have a foot valve of equal or greater area than the pump suction piping when you use an open system with a suction lift.	Prevent clogging by using a strainer at the suction inlet next to the foot valve. Make sure that the strainer has an area three times that of the suction pipe with a mesh hole diameter of no less than 0.25 in. (0.64 cm).	

5 Commissioning, Startup, Operation, and Shutdown

5.1 Preparation for startup



DANGER:

Electrical hazard sufficient to kill. Always disconnect and lock out the power before you service the unit.



WARNING:

- Failure to follow these precautions before you start the unit will lead to serious personal injury and equipment failure.
- Do not operate the pump below the minimum rated flows or with the suction or discharge valves closed. These conditions can create an explosive hazard due to vaporization of pumped fluid and can quickly lead to pump failure and physical injury.
- Always disconnect and lock out power to the driver before you perform any installation or maintenance tasks. Failure to disconnect and lock out driver power will result in serious physical injury.
- Operating the pump in reverse rotation can result in the contact of metal parts, heat generation, and breach of containment.

NOTICE:

- Verify the driver settings before you start any pump.

You must follow these precautions before you start the pump:

- Flush and clear the system thoroughly to remove dirt or debris in the pipe system in order to prevent premature failure at initial startup.
- Verify controller settings match site conditions and motor nameplate data before starting station.

5.1.1 Prestartup checklist



CAUTION:

Risk of leaks or flooding. Make sure to reinstall the drain plugs properly. Check all joints for tightness and flange bolts for the proper torque.

Checks	Checked
Check that the pump is properly aligned. Refer to these manual numbers for more information: <ul style="list-style-type: none"> • eSV pumps = IM228 • NPE pumps = IM013 • SSH pumps = IM084 	
Check that the drain plugs are installed before filling system.	
Inspect all piping joints for tightness. Joints can become loose during transit due to vibration and shock.	
Check all flanged joints for the proper torque.	
Check that the system is full of liquid.	

Checks	Checked
Check that all high points in the piping system are vented in order to remove trapped air.	
Check that all pumps and drivers are properly lubricated.	
Check that the piping is clean and has been flushed.	

5.1.2 Final installation checks

Installation checklist



CAUTION:

Serious damage to the pump may result if it is started dry. Make sure that the pump is completely filled with liquid before it is started.

Check	Checked
Check that the unit base is properly leveled, grouted, and secured.	
Check that all lubrication points are properly lubricated.	
Check that the outlet side of the high-temperature relief valve assembly (if option is purchased) is connected to the drain with tubing or pipe sized 1/2 in. or greater.	
Check that the shut-off valves to the transmitters are open.	
Check that the pump and motor shafts are properly aligned.	
Check that the pump rotation is correct.	
Check that the piping is properly supported. This prevents strains on the unit.	

5.1.3 Final adjustments

Make the final adjustments on these adjustable devices in order to match the exact system requirements.

Thermal relief valve

An **optional** thermal relief valve is installed on the pump discharge in order to prevent potentially dangerous thermal pressure buildup. The valve automatically opens on a temperature increase and closes on a temperature decrease. This valve acts as a safety device; do not remove or plug it. It is factory set to open and discharge when the water temperature in the discharge header reaches between 125°F to 135°F (51°C to 57°C). Make sure that the 1/2 in. NPT opening of this valve assembly is piped to a floor drain in accordance with local codes.

After long periods of operation, the valve seat and disc can become worn or pitted. This allows leaks through the valve in the closed position. You can replace internal parts, if desired.

Low suction pressure switch (optional)

Adjust the setting to 10 psi below the rated suction pressure.

5.2 Pump station startup

5.2.1 Confirm the job site voltage

1. Check these items before you apply power or close the disconnect:
 - a) Check all of the power wiring connections and secure them as required.
 - b) Confirm with the owner/installing contractor if there are plans for any required building automation or remote connections.
 - c) Inspect and/or install any customer remote terminations.
2. Make note of the design data supplied on the data label. The label is located on the inside of the control panel door.

3. Use a volt meter to check the voltage on the incoming power terminals at the disconnect.
4. Compare the voltage to the data on the nameplate.

5.2.2 Connect the storage tank



DANGER:

Explosion hazard. Prevent tank explosion. Do not install the tank when the system shut-off pressure exceeds the tank pressure rating.



DANGER:

Explosion hazard. Prevent tank explosion. Install a pressure relief valve on the tank inlet with a set point no greater than tank rating.

1. Precharge the storage tank before you connect it to the system.
The air precharge needs to be 5 to 10 psi less than the system operating pressure.
2. If the storage tank has already been installed and not precharged, then disconnect the system piping from the tank and equalize it to atmospheric pressure. If an isolation valve and drain are provided, then use them.
3. Apply air pressure to the tank through the air charging valve and pressurize to field conditions.
This needs to be equal to the NFSD restart pressure of 5 to 10 psi below the operating pressure.
4. Reconnect the tank to the system piping. Tank should be installed on the discharge side of the system.

5.2.3 Optional water level control relay

The Level Sensing Probes, which are not provided, are required for the water level control relay (Crouzet - 84870700) to work properly. The connection diagram for the level sensing probes from the relay manufacturer is as follows.

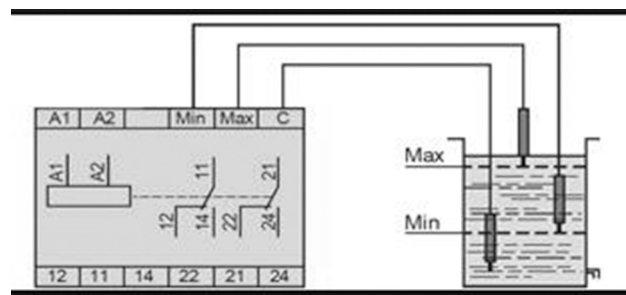

Figure 2: Connection diagram for probes

The relay signal is connected to the Hydrovar drive. If the level sensing probes are not connected, then the relay will give an unhealthy signal ("NO" - Normally Open) and the Hydrovar drive will give an error message as "Lack of Water." The terminals X1:1 - X1:3 are provided in the Electrical Control Panel to connect these probes.

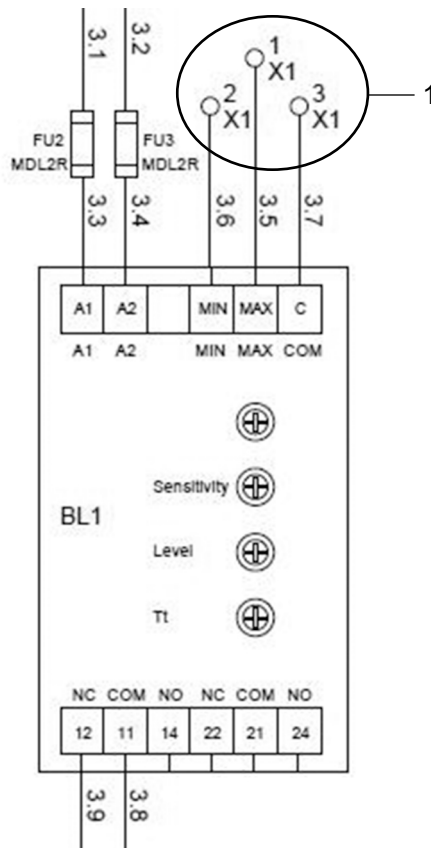

Figure 3: Terminals for probes connection

1. Level sensing probes connection to terminals X1:1 X1:3

Option-I: How to use or connect this relay to run the Hydrovar properly

1. Connect the level sensing probes to the terminals **X1:1, X1:2, X1:3** (Min., Max. and Common).
2. Relay (BL1) will need to use Pin No. 11 and 14 to connect to the Hydrovar drive. Remove the connected wire from Relay (BL1) Pin No. 12 and connect it to Pin No. 14.
3. Once the swapping of the wires and connection of the probes is complete and the water level is reached to set point, then the relay (BL1) will give a healthy signal ("NC"- Normally Closed) to the Hydrovar drive. This signal will be maintained until the water level falls out of the set point range.
4. When the water level is above or below the set point range, then the relay gives an unhealthy signal to the Hydrovar drive, which results in an error message as "Lack of Water."

Option-II: How to by-pass this relay to run the Hydrovar properly

1. If the level sensing probes are not available or level sensing is not required, we need to By-pass the relay to run the Hydrovar smoothly. (As a default, the system is already set-up in a By-pass mode. If you have been running the system with the level control and would like to now by-pass this feature, continue with the following instructions.)
2. For By-pass mode, relay (BL1) will need to use Pin No. 11 and 12 to connect to the Hydrovar drive. Remove the connected wire from Relay (BL1) Pin No. 14 and connect it to Pin No. 12.
3. When these connections are complete, the relay gives a healthy signal continuously and the level sensing feature will get bypassed.

5.2.4 Check for available suction water

1. Open all supply, discharge, and pump isolation valves. Also open any other package valves.
2. Close the bypass valve if it is installed in the piping by others.
3. Inspect the capillary tubing from the pump discharge to the suction header:
 - a) Open the petcocks that feed the tubing.
 - b) Make sure that the plastic tubing does not touch any metal surface. Protect the tubing with insulation in order to prevent abrasion where it can possibly touch metal.
4. Open a faucet in order to create a demand for water on the system pressure piping.
5. Observe the suction pressure and confirm that it is equal to or greater than the suction pressure listed on the nameplate. System is designed for a specific suction pressure. Deviation results in degraded system performance. Contact factory if suction pressure varies from design specifications.

5.2.5 Start the package

1. Close the disconnect in order to apply power to the package.
2. Turn the panel switch to the local position.
3. Watch the screen as the boot-up progresses and note the serial number of the unit. This is the password that you use for the setup menu.
4. If the unit starts, press the Stop button in order to stop the unit.

5.2.6 Check the pump rotation

1. Select the hand mode on the controller.
2. Enable the pump with the blinking green light.
Do not select any of the other pumps (no green light).
3. Press the start button and spin the first pump.
4. Immediately press the Stop button.
5. Observe the spinning shaft for rotation.
6. Repeat steps 1 through 5 for each pump.
7. If all pumps run backwards, reverse the two leads of the incoming power.
8. If only one of the pumps run backwards, reverse the two leads on the pump motors that are incorrect.

5.2.7 Set the system operating pressure

1. Open a faucet or some other demand for water from the discharge of the package. This can be anywhere in the building being served by the package.
2. In hand, run one pump.
3. Repeat these steps for each pump in the package. Run only one pump at a time.

5.2.8 Enter the setup menu

1. For each pump, confirm the settings entered for the pump motor data.
2. Review all settings for the compatibility with the installed application.
3. Make sure that these settings are in place:
 - Auto alt. prd. - 24 or 168 hours
 - Forced destage timer - 10 to 15 minutes
 - NFSD restart psi - Enter a value 5 to 10 psi less than the site-adjusted discharge pressure
 - NFSD minimum run timer - 5 minutes
 - NFSD test PR timer - 20 seconds
4. Adjust any other settings in order to meet the needs of your system.

5.2.9 Test the package

1. Exit the setup menu.
 2. Stop the package.
 3. Press the Auto key and then Start.
 4. Observe the pressures and temperatures for normal operation.
 5. Press the Alternation key and observe the operation of each pump.
 6. Close the running water faucet.
It is assumed that no demand for water is required. For example, no flow.
 7. Observe the No Flow Shutdown sequence. All minimum run timers must elapse for this sequence to occur.
 8. Demand water from the system and observe the restart of the package.
- If you encountered no problems, then you are done.

6 Maintenance

6.1 Precautions



DANGER:

Electrical hazard sufficient to kill. Always disconnect and lock out the power before you service the unit.



WARNING:

- This manual clearly identifies accepted methods for disassembling units. These methods must be adhered to. Trapped liquid can rapidly expand and result in a violent explosion and injury. Never apply heat to impellers, propellers, or their retaining devices to aid in their removal.
 - Make sure that each pump and the package are isolated from the system and that pressure is relieved before you disassemble the pump, remove plugs, open vent or drain valves, or disconnect the package piping.
 - Always disconnect and lock out power to the package and the driver before you perform any installation or maintenance tasks. Failure to disconnect and lock out driver power will result in serious physical injury.
 - Crush hazard. The unit and the components can be heavy. Use proper lifting methods and wear steel-toed shoes at all times.
 - Rotating shaft. Make sure that the packing adjustment is performed by qualified personnel only.
-



CAUTION:

Equipment damage hazard. Silt buildup is a sign of problems with the wet well and/or intake screen. Failure to follow these instructions indicates a potentially hazardous situation, which, if not avoided, may result in property damage.

6.2 Monthly maintenance

Control panel checks

- Verify that all of the operator interface keys and LEDs operate properly (see controller manual).
- Review the station operation, fault history, and data log for station operation.
- Verify that all surge devices are visually sound, where applicable.
 - Check the surge device for the station which is mounted on the back of the control panel.
 - Black soot on or around the device indicates that it has taken a surge and needs to be replaced.

Motor lubrication checks

- For grease-filled bearings, make sure that grease is not all over the inside of the motor and in the bottom of the motor. This could be a sign of overfilling. Refer to the lubrication instructions from the motor manufacturer.

Close-coupled pumps

- For a horizontal pump, verify that the mechanical seal is not leaking between the pump and the motor.

Sound and visual checks of the whole station

- Listen for any odd sounds that rub or grind, electrical arcing, and check for anything that is binding or unusual. These conditions can indicate a serious problem.

Note that there is going to be some harmonic vibration with the pumps and motor. Listen for excessive vibration or noise as this requires immediate service. Do not operate the pump if there is excessive vibration.

- Confirm that the building cooling and ventilation systems are operating and clear of all obstructions. The maximum operating range for equipment is 104°F (40°C).
- Verify that water, grease, oil, and hardware are not leaking or loose on the pump station.

Station skid

- Visually inspect for leaks in the station piping, valves, and other components.
- Visually inspect the piping and skid for any stress cracks in the welds.
- Visually inspect the station for loose or damaged paint or areas of rust.

7 Troubleshooting

7.1 Pump station troubleshooting



DANGER:

- Personal injury hazard. Troubleshooting a live control panel exposes personnel to hazardous voltages. Electrical troubleshooting must be done by a qualified electrician. Failure to follow these instructions will result in serious personal injury, death, and/or property damage.
- Electrical hazard sufficient to kill. Always disconnect and lock out the power before you service the unit.



WARNING:

Electrical connections must be made by certified electricians in compliance with all international, national, state, and local rules.

Note that some troubleshooting procedures apply to only constant speed systems or only variable speed systems.

Use these Installation, Operation, and Maintenance manuals for more information:

- e-SV pumps = IM228
- NPE pumps = IM013
- SSH pumps = IM084

7.1.1 The pump station does not power up

Cause	Remedy
The site voltage does not match the pump station voltage.	Make sure that the site voltage matches the pump station design voltage.
Line-to-line voltage is not balanced.	Check incoming voltage and amperage. Line-to-line voltage should be balanced. Line-to-ground voltage should also be balanced.
The power fuses are blown or breakers are tripped.	Check power fuses and breakers. Breakers are shipped in the OFF position. Replace blown fuses.
The pump station is not properly grounded (earthed).	Check that proper grounding (earthing) techniques have been used for the pump station.
There is a fault.	Check for fault codes or fault lights on the PLC. Correct the fault.

7.1.2 The station powers up, but the pumps do not run

Cause	Remedy
Pumps are not enabled.	Check the PLC to make sure that the pumps are enabled. Check for faults. Correct any faults.
The desired pressure is satisfied.	Check to see if the desired pressure is satisfied. If the actual pressure is greater than the set point pressure, then the pumps are automatically stopped.
There is a fault.	Check for fault codes or fault lights on the PLC. Correct the fault.
The motor is tripped.	Check for a tripped motor thermal protector. Allow motor to cool, and then reset the thermal protector.
The fuses are blown or breakers are tripped.	Check circuit breaker and fuses.

Cause	Remedy
Transducer isolation valves are closed.	Make sure that the transducer isolation valves are in the open position.
Automatic mode is faulty.	Check to see if the pump can be run in Manual mode on the PLC.
The impeller is bound.	Check to see if you can turn the pump by hand. Check for a bound impeller.
A pressure transducer is faulty.	Replace faulty pressure transducers.
Motor wiring is loose.	Make sure that motor wiring is securely connected.
Motor windings have lost insulation strength.	Test the motor leads with a megger in order to check the motor windings.
Variable speed drive is wired incorrectly.	Check corresponding variable speed drive. Make sure drive is wired correctly.
Motor is defective.	Repair or replace motor.

7.1.3 The pumps run but do not build desired pressure

Cause	Remedy
Pumps are running off their design curve.	Check the application. Is the system running in an open discharge condition (excessive flow rate)? For example, is the system filling a large irrigation line for the first time of the season?
Pumps are running at less than full speed.	Check to see if the pumps are running at full speed. If they are running less than full speed, they could be experiencing electrical issues. Check the panel for power status.
The inlet pressure does not match the project specifications.	Check to see if the inlet pressure matches the project specifications. Variations in inlet pressure can have detrimental effects on performance.
A pipe is broken.	Check for broken pipes.
The transducer isolation valves are closed.	Check to be sure that the transducer isolation valves are in the open position.
The NPSH is insufficient.	Check the NPSH. Are proper flooded conditions or positive pressure being delivered to the pump station? Check for air in the supply lines. Check for properly filled supply tanks (if applicable). Excessive suction lift or piping losses will limit the life expectancy of the pumps.
The pump station has lost its prime.	Check to be sure that the pump station has been primed properly. Make sure that all pumps and components are properly filled with water.
The pump rotation is incorrect.	Check the pump rotation. Proper rotation is indicated on the pump volute. (See the pump IOM.)
A suction or discharge valve is closed or clogged.	Check the isolation valves and check valves. Are all suction/discharge valves open? Could any valves be plugged? Could the pumps be plugged?
The motor is not operating at the rated RPM.	Check the voltage and amperage. Check for possible phase loss to the motor.
The impeller is worn or plugged.	Take the pump to an authorized pump repair facility.
The pump bearings are worn.	Take the pump to an authorized pump repair facility.

7.1.4 The pump station experiences excessive vibration

Cause	Remedy
The motor, pump, or piping is loose.	Make sure that all fasteners and components are properly tightened.
Pump station vibration dampers are missing or improperly installed.	Check for properly installed pump station vibration dampers.
Pumps are running off their design curve.	Check the application. Is the system running in an open discharge condition (excessive flow rate)? For example, is the system filling a large irrigation line for the first time of the season?
Air or gases are present in the pumped liquid.	Check water supply lines and tanks. Check for air or gases in liquid. Bleed the lines.
Discharge piping is plugged.	Check discharge piping/valves. Could the piping be plugged? Could the pump be plugged? Are the isolation valves open? Clear any clogs.
Supply piping has excessive suction/lift conditions or friction loss.	Check for excessive suction/lift conditions or friction loss on supply piping.
The impeller is bound or worn.	Take the pump to an authorized pump repair facility.
Pumps and pipes are not properly aligned.	Correct the alignment between pumps and pipes.

7.1.5 The pump station does not shut down and no water is used

Cause	Remedy
The pump station is in Hand or Manual mode.	Put the system in the AUTO position.
The system pressure is set beyond capability of the station.	Check the system set pressure. Is this duty point beyond the capability of the pump station?
There are leaks or broken pipes.	Check for broken pipes or leaks. Does the system pressure decrease if the pump station is turned off?
The diaphragm tank is faulty.	Check for a properly installed diaphragm tank. Has the tank failed? Has the tank been charged to the proper operating pressure before installation? (~ 10 psi below the desired set point)
The pressure transducers are faulty.	Check the pressure transducers. Does the actual mechanical gauge pressure match the pressure displayed on the VFDs and the PLC?
The VFDs are in Local mode.	Put the VFDs in Remote mode.
A check valve is malfunctioning.	Check for malfunctioning check valves. Does the system hold pressure when the pump package is shut down? Replace faulty valves.

7.1.6 The pump station cycles or hunts erratically

Cause	Remedy
The pumps are oversized for the current demand.	Check the application. Possibly increase the size of the bladder tank for low demand situations.
The inlet pressure is fluctuating.	Check the application. Possibly increase the size of the bladder tank for low demand situations.
There are leaks or broken pipes.	Check for broken pipes or leaks. Does the system pressure decrease when the pump station is turned off?
The diaphragm tank is faulty.	Check for a properly installed diaphragm tank. Has the tank failed? Has the tank been charged to the proper operating pressure before installation? (~ 10 psi below the desired set point)

Cause	Remedy
The pressure transducers are faulty.	Check the pressure transducers. Does the actual mechanical gauge pressure match the pressure displayed on the VFDs.
A check valve is malfunctioning.	Check for malfunctioning check valves. Replace faulty valves.
There is an error in the PLC programming.	Check the customer programming on the PLC. Correct any errors.

8 Technical Reference

8.1 Pump station numbering system

The pump station label located on the inside of the control enclosure door identifies the product code number for the various versions of the pump systems. This number is also the catalog number for the pump station. The pump station numbering systems describe the meaning of each digit.

Not all combinations are possible.

8.1.1 Pump station with e-SV pumps

Example product code

V	2	VF	C	2	A	2	1	A	1	BCD
---	---	----	---	---	---	---	---	---	---	-----

Numbering system definitions

First character: Variable or constant speed	
V = variable speed	L = XL variable speed

Second character: Number of pumps	
2, 3, or 4	

Third character: Pump type and size	
VA = 1SV	VG = 33SV
VB = 3SV	VH = 46SV
VC = 5SV	VJ = 66SV
VD = 10SV	VK = 92SV
VE = 15SV	VM = 125SV
VF = 22SV	

Fourth character: Header size	
C = 3 in.	E = 6 in.
D = 4 in.	F = 8 in.

Fifth character: Supply voltage	
2 = 208 V / 1 PH / 60 Hz	6 = 460 V / 3 PH / 60 Hz
3 = 230 V / 1 PH / 60 Hz	7 = 575 V / 3 PH / 60 Hz
4 = 208 V / 3 PH / 60 Hz	8 = 380 V / 3 PH / 60 Hz
5 = 230 V / 3 PH / 60 Hz	9 = 380 V / 3 PH / 50 Hz

Sixth character: HP rating				
A = 1/2	E = 2	J = 10	N = 30	T = 75
B = 3/4	F = 3	K = 15	P = 40	U = 100
C = 1	G = 5	L = 20	R = 50	V = 125
D = 1-1/2	H = 7-1/2	M = 25	S = 60	W = 150

Seventh character: Stages / impeller size	
1 = 1, 2 = 2, 3 = 3, and so forth	

Eighth character: reduced number of stages
0 = 0 reduced, 1 = 1 reduced, 2 = 2 reduced, and so forth

Ninth character: Branch	
A = 1.5 in. Chk	D = 3 in. Chk
B = 2 in. Chk	E = 4 in. Chk
C = 2.5 in. Chk	F = 6 in. Chk

Tenth character
For factory use

Eleventh character: Options
B = Suction pressure switch
G = Suction pressure sensor
J = LOP
C = High temperature relief valve
D = System flex connectors
F = Lightning arrestor

Special options for B, G, J	Variable
Lift/flooded	LOP (option J)
Boost (greater than 10 PSI)	Switch (option B or G)

8.1.2 Pump station with NPE pumps

Example product code

C	2	N2	C	2	A	B	G	2	BCD
---	---	----	---	---	---	---	---	---	-----

Numbering system definitions

First character: Variable or constant speed	
V = variable speed	L = XL variable speed

Second character: Number of pumps
2, 3, or 4

Third character: Pump type and size	
N1 = 1ST	N3 = 3ST
N2 = 2ST	

Fourth character: Header size		
C = 3 in.	E = 6 in.	G = 10 in.
D = 4 in.	F = 8 in.	H = 12 in.

Fifth character: Supply voltage	
2 = 208 V / 1 PH / 60 Hz	6 = 460 V / 3 PH / 60 Hz
3 = 230 V / 1 PH / 60 Hz	7 = 575 V / 3 PH / 60 Hz
4 = 208 V / 3 PH / 60 Hz	8 = 380 V / 3 PH / 60 Hz
5 = 230 V / 3 PH / 60 Hz	9 = 380 V / 3 PH / 50 Hz

Sixth character: HP rating	
A = 1/2	E = 2
B = 3/4	F = 3
C = 1	G = 5
D = 1-1/2	H = 7-1/2

Seventh character: Trim			
	1ST	2ST	3ST
A	6-1/8	5-1/4	4-3/4
B	5-3/4	5-1/16	4-5/8
C	5-3/16	4-7/8	4-3/8
D	4-3/4	4-5/8	4-1/16
E	4-7/16	4-1/4	3-5/8
F	4-1/16	3-7/8	–
G	–	5-15/16	5-3/8
H	–	5-1/2	5
K	–	6-1/8	5-3/8

Eighth character: Branch size / discharge valve type		
A = 1.5 in. Chk	D = 3 in. Chk	G = 1.5 in. Chk
B = 2 in. Chk	E = 4 in. Chk	
C = 2.5 in. Chk	F = 6 in. Chk	

Ninth character
For factory use

Tenth character: Options
B = Suction pressure switch
G = Suction pressure sensor
J = LOP
C = High temperature relief valve
D = System flex connectors
F = Lightning arrester

Special options for B, G, J	Variable
Lift/flooded	LOP (option J)
Boost (greater than 10 PSI)	Switch (option B or G)

8.1.3 Pump station with SSH pumps

Example product code

V	2	HE	F	4	P	A	L	2	BCD
---	---	----	---	---	---	---	---	---	-----

Numbering system definitions

First character: Variable or constant speed	
V = variable speed	L = XL variable speed

Second character: Number of pumps
2, 3, or 4

Third character: Pump type and size			
H9 = 9SH	HA = 10SH	HB = 11SH	H4 = 4SH
H7 = 7SH	H5 = 5SH	H8 = 8SH	H6 = 6SH
HC = 24SH	HD = 25SH	HE = 22SH	HF = 27SH
HG = 23SH	HH = 28SH	-	-

Fourth character: Header size		
C = 3 in.	E = 6 in.	G = 10 in.
D = 4 in.	F = 8 in.	H = 12 in.

Fifth character: Supply voltage	
2 = 208 V / 1 PH / 60 Hz	6 = 460 V / 3 PH / 60 Hz
3 = 230 V / 1 PH / 60 Hz	7 = 575 V / 3 PH / 60 Hz
4 = 208 V / 3 PH / 60 Hz	8 = 380 V / 3 PH / 60 Hz
5 = 230 V / 3 PH / 60 Hz	9 = 380 V / 3 PH / 50 Hz

Sixth character: HP rating				
A = 1/2	E = 2	J = 10	N = 30	T = 75
B = 3/4	F = 3	K = 15	P = 40	U = 100
C = 1	G = 5	L = 20	R = 50	V = 125
D = 1-1/2	H = 7-1/2	M = 25	S = 60	W = 150

Seventh character: Trim														
	9SH	10SH	11SH	4SH	7SH	5SH	8SH	6SH	22SH	23SH	24SH	25SH	27SH	28SH
A	6-5/8	8-27/64	10-3/32	6-3/4	8-1/4	6-7/8	8-1/4	7-5/16	9-1/16	9-1/16	9-7/8	9-7/8	10-3/8	10-5/8
B	6-7/16	8-1/16	9-17/32	6-3/8	7-13/16	6-7/16	7-3/4	7-1/8	8-3/4	8-11/16	9-1/2	9-1/2	9-15/16	10-1/4
C	5-11/16	7-11/16	9-1/8	6-1/16	7	5-13/16	7-1/2	6-15/16	8-1/2	8-6/16	9-3/16	9-1/8	9-9/16	9-13/16
D	5-3/8	7-3/8	8-3/4	5-5/8	6-3/4	5-1/2	7-3/16	6-11/16	8-1/4	8-1/16	8-7/8	8-13/16	9-1/4	9-7/16
E	-	7-1/8	-	5-5/16	6-7/16	5-1/8	6-7/8	6-3/8	7-7/8	7-11/16	8-9/16	8-3/16	8-3/4	9-1/16
F	-	-	-	4-11/16	6-1/8	4-13/16	6-3/16	6-1/16	7-1/2	7-1/2	8-1/4	7-15/16	-	-
G	-	-	-	4-3/8	-	4-7/16	-	5-5/8	7-1/8	7-1/8	-	7-11/16	-	-
H	-	-	-	4-3/16	-	4-1/4	-	-	6-11/16	6-7/8	-	-	-	-
J	-	-	-	3-7/8	-	-	-	-	6-1/2	6-1/2	-	-	-	-
K	-	-	-	-	-	-	-	-	-	6	-	-	-	-
L	-	-	-	-	-	-	-	-	-	5-1/2	-	-	-	-

Eighth character: Branch size / discharge valve type		
A = 1.5 in. Chk	D = 3 in. Chk	G = 1.5 in. Chk
B = 2 in. Chk	E = 4 in. Chk	
C = 2.5 in. Chk	F = 6 in. Chk	

Ninth character
For factory use

Tenth character: Options	
B = Suction pressure switch	
G = Suction pressure sensor	
J = LOP	
C = High temperature relief valve	
D = System flex connectors	
F = Lightning arrestor	

Special options for B, G, J	Variable
Lift/flooded	LOP (option J)
Boost (greater than 10 PSI)	Switch (option B or G)

9 Appendix

9.1 Installation drawings

Duplex 3SV-5SV

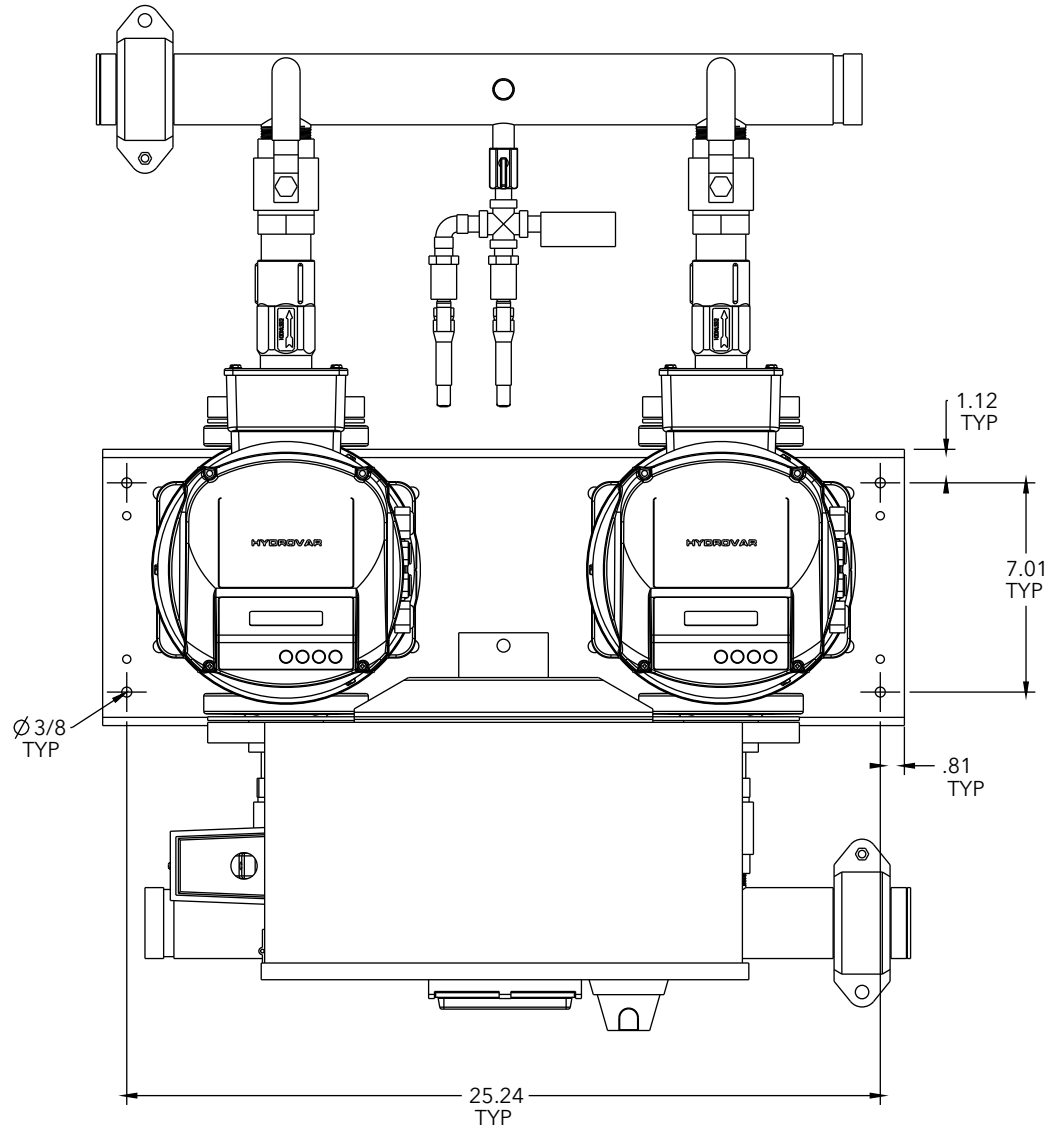

Duplex 10SV-15SV

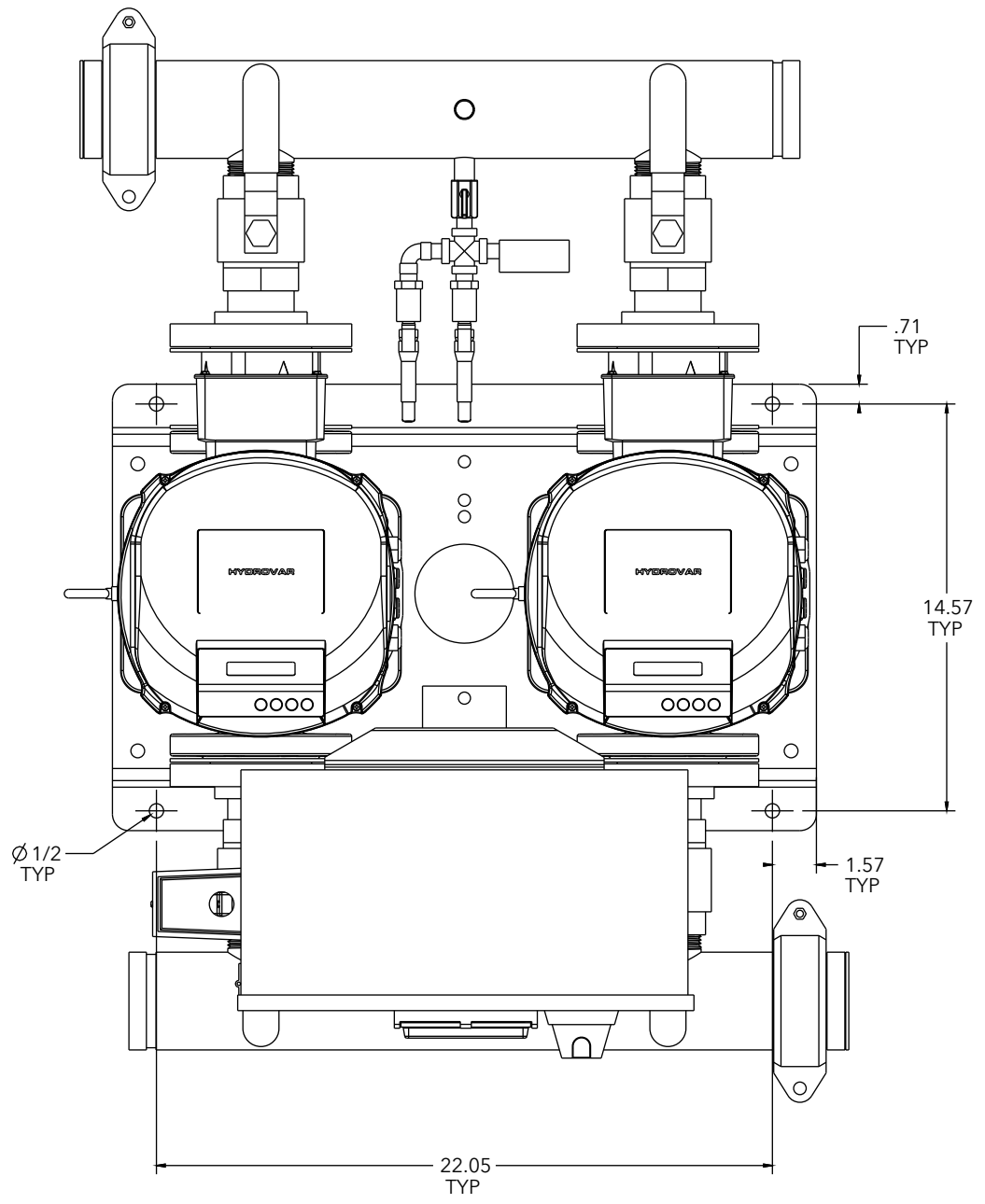

Duplex 15SV6-33SV

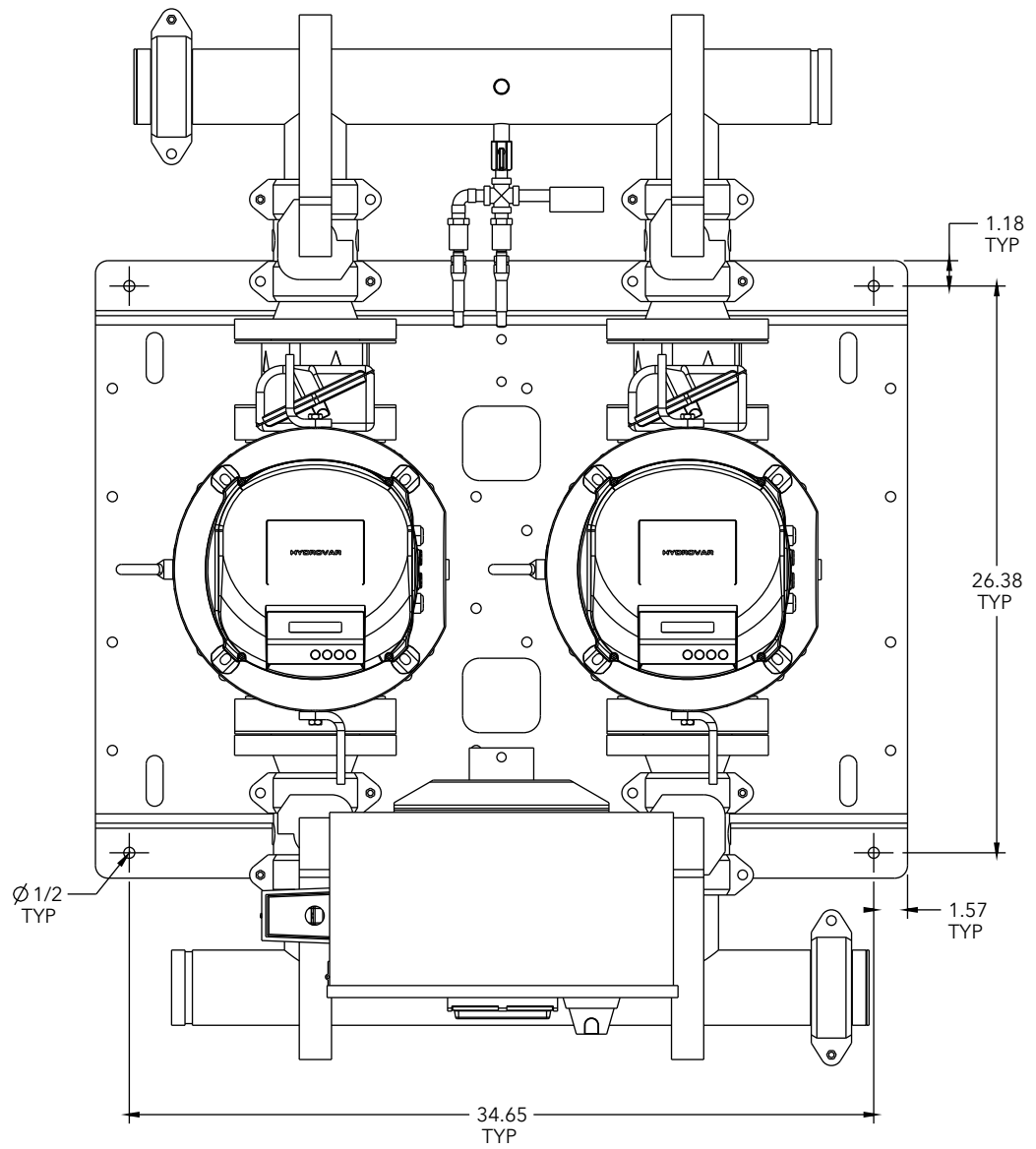

Triplex 3SV-15SV

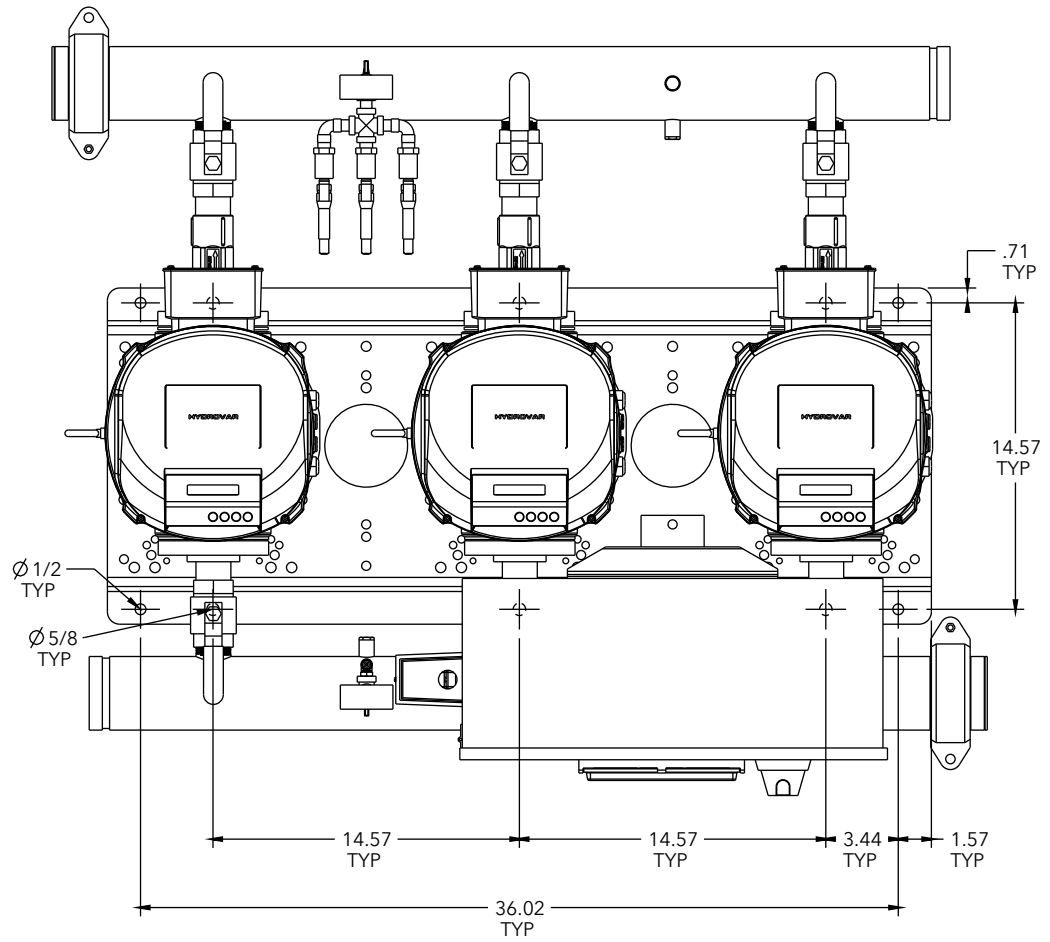

Triplex 15SV6-33SV

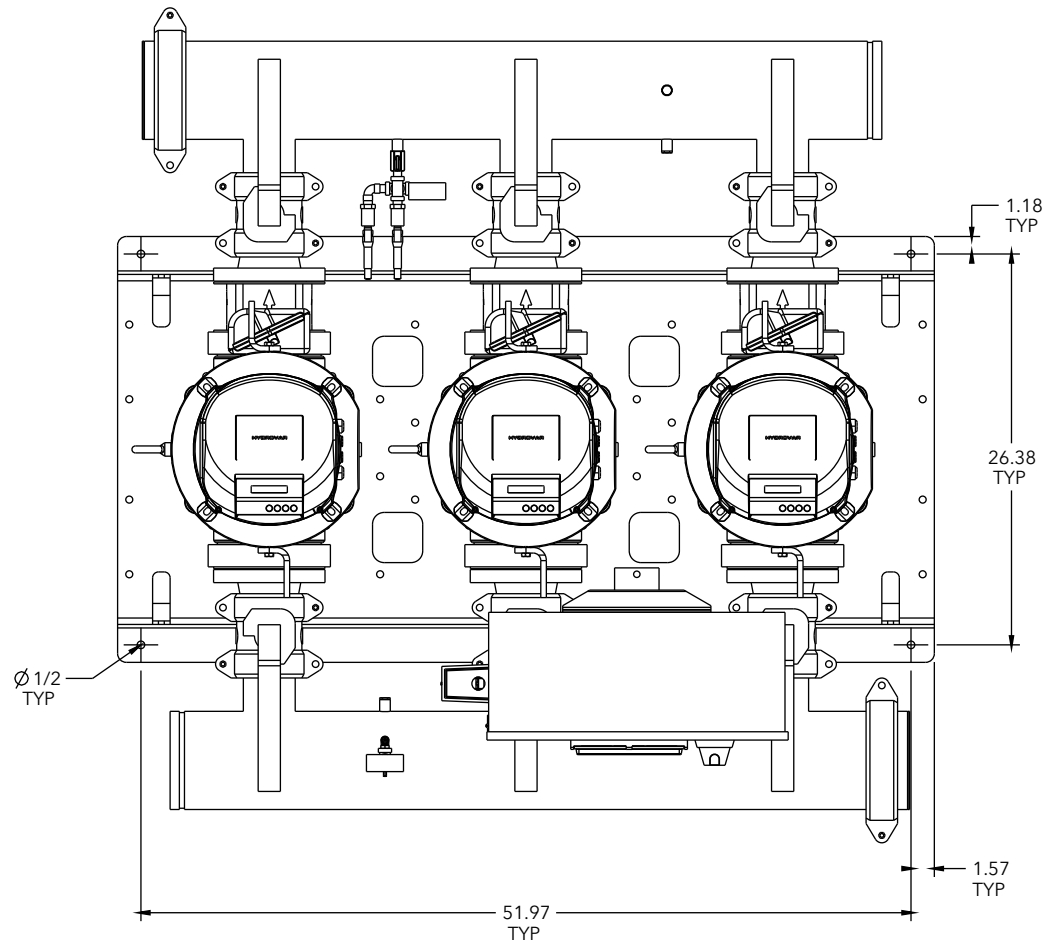

Quadplex 3SV-15SV5

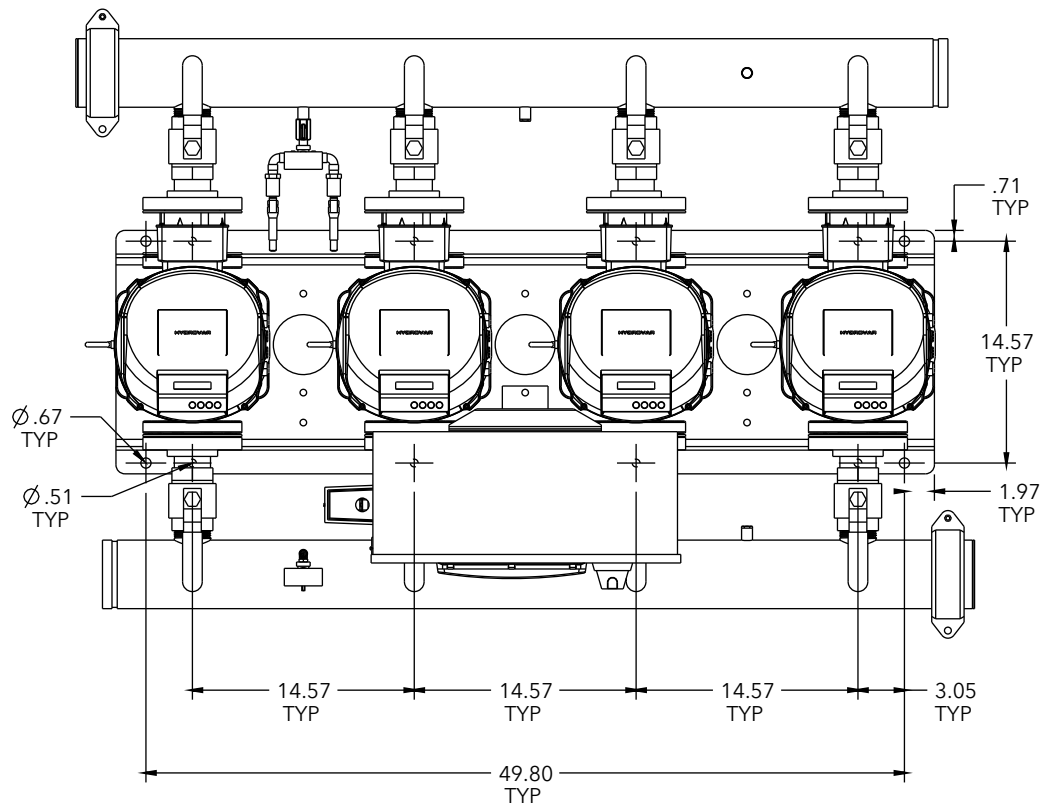

Quadplex 15SV6-33SV

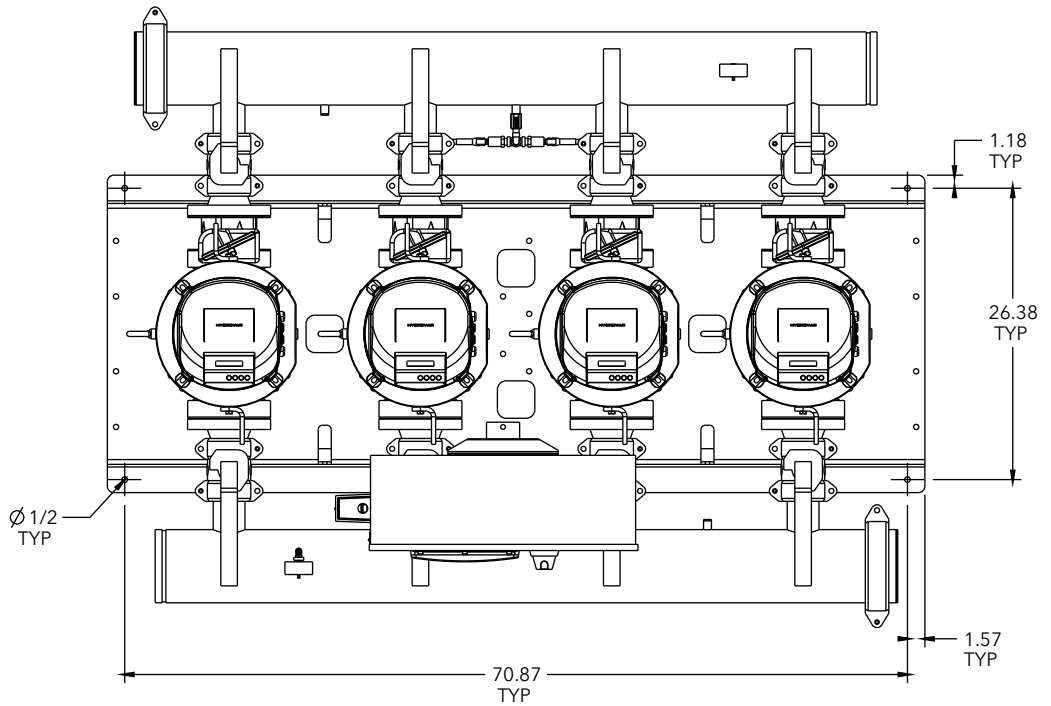

10 Product warranty

Commercial warranty

Warranty. For goods sold to commercial buyers, Seller warrants the goods sold to Buyer hereunder (with the exception of membranes, seals, gaskets, elastomer materials, coatings and other "wear parts" or consumables all of which are not warranted except as otherwise provided in the quotation or sales form) will be (i) be built in accordance with the specifications referred to in the quotation or sales form, if such specifications are expressly made a part of this Agreement, and (ii) free from defects in material and workmanship for a period of one (1) year from the date of installation or eighteen (18) months from the date of shipment (which date of shipment shall not be greater than thirty (30) days after receipt of notice that the goods are ready to ship), whichever shall occur first, unless a longer period is specified in the product documentation (the "Warranty").

Except as otherwise required by law, Seller shall, at its option and at no cost to Buyer, either repair or replace any product which fails to conform with the Warranty provided Buyer gives written notice to Seller of any defects in material or workmanship within ten (10) days of the date when any defects or non-conformance are first manifest. Under either repair or replacement option, Seller shall not be obligated to remove or pay for the removal of the defective product or install or pay for the installation of the replaced or repaired product and Buyer shall be responsible for all other costs, including, but not limited to, service costs, shipping fees and expenses. Seller shall have sole discretion as to the method or means of repair or replacement. Buyer's failure to comply with Seller's repair or replacement directions shall terminate Seller's obligations under this Warranty and render the Warranty void. Any parts repaired or replaced under the Warranty are warranted only for the balance of the warranty period on the parts that were repaired or replaced. Seller shall have no warranty obligations to Buyer with respect to any product or parts of a product that have been: (a) repaired by third parties other than Seller or without Seller's written approval; (b) subject to misuse, misapplication, neglect, alteration, accident, or physical damage; (c) used in a manner contrary to Seller's instructions for installation, operation and maintenance; (d) damaged from ordinary wear and tear, corrosion, or chemical attack; (e) damaged due to abnormal conditions, vibration, failure to properly prime, or operation without flow; (f) damaged due to a defective power supply or improper electrical protection; or (g) damaged resulting from the use of accessory equipment not sold or approved by Seller. In any case of products not manufactured by Seller, there is no warranty from Seller; however, Seller will extend to Buyer any warranty received from Seller's supplier of such products.

THE FOREGOING WARRANTY IS EXCLUSIVE AND IN LIEU OF ANY AND ALL OTHER EXPRESS OR IMPLIED WARRANTIES, GUARANTEES, CONDITIONS OR TERMS OF WHATEVER NATURE RELATING TO THE GOODS PROVIDED HEREUNDER, INCLUDING WITHOUT LIMITATION ANY IMPLIED WARRANTIES OF MERCHANTABILITY AND FITNESS FOR A PARTICULAR PURPOSE, WHICH ARE HEREBY EXPRESSLY DISCLAIMED AND EXCLUDED. EXCEPT AS OTHERWISE REQUIRED BY LAW, BUYER'S EXCLUSIVE REMEDY AND SELLER'S AGGREGATE LIABILITY FOR BREACH OF ANY OF THE FOREGOING WARRANTIES ARE LIMITED TO REPAIRING OR REPLACING THE PRODUCT AND SHALL IN ALL CASES BE LIMITED TO THE AMOUNT PAID BY THE BUYER FOR THE DEFECTIVE PRODUCT. IN NO EVENT SHALL SELLER BE LIABLE FOR ANY OTHER FORM OF DAMAGES, WHETHER DIRECT, INDIRECT, LIQUIDATED, INCIDENTAL, CONSEQUENTIAL, PUNITIVE, EXEMPLARY OR SPECIAL DAMAGES, INCLUDING BUT NOT LIMITED TO LOSS OF PROFIT, LOSS OF ANTICIPATED SAVINGS OR REVENUE, LOSS OF INCOME, LOSS OF BUSINESS, LOSS OF PRODUCTION, LOSS OF OPPORTUNITY OR LOSS OF REPUTATION.

Limited consumer warranty

Warranty. For goods sold for personal, family or household purposes, Seller warrants the goods purchased hereunder (with the exception of membranes, seals, gaskets, elastomer materials, coatings and other "wear parts" or consumables all of which are not warranted except as otherwise provided in the quotation or sales form) will be free from defects in material and workmanship for a period of one (1) year from the date of installation or eighteen (18) months from the product date code, whichever shall occur first, unless a longer period is provided by law or is specified in the product documentation (the "Warranty").

Except as otherwise required by law, Seller shall, at its option and at no cost to Buyer, either repair or replace any product which fails to conform with the Warranty provided Buyer gives written notice to Seller of any defects in material or workmanship within ten (10) days of the date when any defects or non-conformance are first manifest. Under either repair or replacement option, Seller shall not be obligated to remove or pay for the removal of the defective product or install or pay for the installation of the replaced or repaired product and Buyer shall be responsible for all other costs, including, but not limited to, service costs, shipping fees and expenses. Seller shall have sole discretion as to the method or means of repair or replacement. Buyer's failure to comply with Seller's repair or replacement directions shall terminate Seller's obligations under this Warranty and render this Warranty void. Any parts repaired or replaced under the Warranty are warranted only for the balance of the warranty period on the parts that were repaired or replaced. The Warranty is conditioned on Buyer giving written notice to Seller of any defects in material or workmanship of warranted goods within ten (10) days of the date when any defects are first manifest.

Seller shall have no warranty obligations to Buyer with respect to any product or parts of a product that have been: (a) repaired by third parties other than Seller or without Seller's written approval; (b) subject to misuse, misapplication, neglect, alteration, accident, or physical damage; (c) used in a manner contrary to Seller's instructions for installation, operation and maintenance; (d) damaged from ordinary wear and tear, corrosion, or chemical attack; (e) damaged due to abnormal conditions, vibration, failure to properly prime, or operation without flow; (f) damaged due to a defective power supply or improper electrical protection; or (g) damaged resulting from the use of accessory equipment not sold or approved by Seller. In any case of products not manufactured by Seller, there is no warranty from Seller; however, Seller will extend to Buyer any warranty received from Seller's supplier of such products.

THE FOREGOING WARRANTY IS PROVIDED IN PLACE OF ALL OTHER EXPRESS WARRANTIES. ALL IMPLIED WARRANTIES, INCLUDING BUT NOT LIMITED TO THE IMPLIED WARRANTIES OF MERCHANTABILITY AND FITNESS FOR A PARTICULAR PURPOSE, ARE LIMITED TO ONE (1) YEAR FROM THE DATE OF INSTALLATION OR EIGHTEEN (18) MONTHS FROM THE PRODUCT DATE CODE, WHICHEVER SHALL OCCUR FIRST. EXCEPT AS OTHERWISE REQUIRED BY LAW, BUYER'S EXCLUSIVE REMEDY AND SELLER'S AGGREGATE LIABILITY FOR BREACH OF ANY OF THE FOREGOING WARRANTIES ARE LIMITED TO REPAIRING OR REPLACING THE PRODUCT AND SHALL IN ALL CASES BE LIMITED TO THE AMOUNT PAID BY THE BUYER FOR THE DEFECTIVE PRODUCT. IN NO EVENT SHALL SELLER BE LIABLE FOR ANY OTHER FORM OF DAMAGES, WHETHER DIRECT, INDIRECT, LIQUIDATED, INCIDENTAL, CONSEQUENTIAL, PUNITIVE, EXEMPLARY OR SPECIAL DAMAGES, INCLUDING BUT NOT LIMITED TO LOSS OF PROFIT, LOSS OF ANTICIPATED SAVINGS OR REVENUE, LOSS OF INCOME, LOSS OF BUSINESS, LOSS OF PRODUCTION, LOSS OF OPPORTUNITY OR LOSS OF REPUTATION.

Some states do not allow limitations on how long an implied warranty lasts, so the above limitation may not apply to you. Some states do not allow the exclusion or limitation of incidental or consequential damages, so the above exclusions may not apply to you. This warranty gives you specific legal rights, and you may also have other rights which may vary from state to state.

To make a warranty claim, check first with the dealer from whom you purchased the product or visit www.xylem.com for the name and location of the nearest dealer providing warranty service.

Xylem |'zīləm|

- 1) The tissue in plants that brings water upward from the roots;
- 2) a leading global water technology company.

We're a global team unified in a common purpose: creating advanced technology solutions to the world's water challenges. Developing new technologies that will improve the way water is used, conserved, and re-used in the future is central to our work. Our products and services move, treat, analyze, monitor and return water to the environment, in public utility, industrial, residential and commercial building services settings. Xylem also provides a leading portfolio of smart metering, network technologies and advanced analytics solutions for water, electric and gas utilities. In more than 150 countries, we have strong, long-standing relationships with customers who know us for our powerful combination of leading product brands and applications expertise with a strong focus on developing comprehensive, sustainable solutions.

For more information on how Xylem can help you, go to www.xylem.com



Xylem Inc.
2881 East Bayard Street Ext., Suite A
Seneca Falls, NY 13148
USA
Tel: (844) XYL-PUMP [844-995-7867]
Fax: (888) 322-5877
www.xylem.com/goulds

Visit our Web site for the latest version of this document and more information

The original instruction is in English. All non-English instructions are translations of the original instruction.

© 2019 Xylem Inc

Goulds is a registered trademark of Goulds Pumps, Inc. and is used under license.