	<b>GE STEAM POWER</b>				<b>HDST601100</b>
	Resp. Dept.: 1350	Replaces: HDST601100_MJ	Revision: MK	Doc Type: DC	File no.:
Prepared: 2021-12-07 J. Hauser	Checked: 2021-12-07 M. Tröndle	Approved: 2021-12-07 A. Rebholz	Language: EN	Page: 1 / 33	

Export Controlled:	<input type="radio"/> Yes <input checked="" type="radio"/> No	ECCN:	US origin:	<input type="radio"/> Yes <input checked="" type="radio"/> No
--------------------	---	-------	------------	---

-Non-Public- Not to be copied, reproduced or distributed outside of GE without prior approval  
Uncontrolled when printed or transmitted electronically

## Packaging Instruction

Content	Page
1 General .....	2
2 Packaging Requirements .....	2
3 Use of ISO Containers.....	3
4 Packing Protocol and Inspection .....	3
5 Dangerous Goods .....	3
6 Transport Drawing .....	3
7 Marks .....	4
8 Packing List.....	4
9 Packaging Material Requirements.....	5
A Appendix A - Types of Export Packing .....	7
B Appendix B - Corrosion Protection.....	25

Dept.	Document No.	Type	Rev.	Released	Lang.	Status
1350	HDST601100	DC	MK	2021-12-07	EN	Approved



## 1 General

This instruction HDST601100 fits within a set of packaging instructions issued to Suppliers. Table 1 defines the order of precedence of packaging instructions.

This instruction defines the minimum packaging requirements and prescribed packaging methods if either a GE product specific packaging instruction or a supplier specific packaging instruction approved by GE's Transport Logistics does not exist.

The Supplier shall decide which protection and preservation measures shall be adopted to meet the requirements of this instruction (as per section 2) and the needs of the product – in respect of the sensitivity and inherent nature of the product.

Adhering to this instruction does not minimise the liability of the Supplier for product damage resulting from inadequate packaging and/or inherent vice. The Supplier must know to what extent his product is susceptible to damage during transport and storage.

The Supplier shall subcontract his packaging scope to a company certified as per ISO 9001 / 14001 or equivalent standards and being capable to meet these packing requirements should the Supplier not be able fulfil these minimum requirements himself.

In respect of packing, labelling, marking and declaration of dangerous goods, it is the Suppliers responsibility to ensure that he and/or his appointed subcontractors hold relevant qualifications and certification issued by the respective governing bodies. GE reserves the right to request copies of such valid certifications.

Project and/or country specific packaging requirements are defined in Shipping, Packing and Marking Instructions circulated by GE Transport Logistics.

Precedence	Regulation
1	GE product specific packaging instruction
2	Supplier specific packaging instruction approved by GE's Transport Logistics
3	HDST601100
4	National industry standards (e.g. S.E.I., HPE, ANSI, ...)

Table 1: Order of preceding packing instructions

## 2 Packaging Requirements

The packaging must fulfil the following requirements:

- Protection against mechanical stress and damage such as
  - stacking pressure of at least 1.0 t/m<sup>2</sup> and stacking height of 8 m;
  - impacts and accelerations of maximum 1 g or 9.81 m/s<sup>2</sup> during transport and handling;
  - Air transport: special requirements apply, need to consult air carrier early. Typical G accelerations to design packaging for are: 2.3g forwards, 1.5g rearwards, 2g up, 2.5g down (AN124)
  - vibration (e.g. transport over poor roads);
  - forces resulting from frequent loading and transferring; and
  - compression resulting from lifting with slings.
- Protection against environmental factors over a period of at least 12 months such as
  - corrosion caused by effects of relative humidity;
  - contamination, decomposition and rotting resulting from industrial exhaust fumes, saline air, rain, snow, splash water, mould etc.;
  - temperatures between -25°C up to +70°C and major short termed temperature changes during transport and storage; and
  - mechanical damage caused by rodents or abrasion resulting from dust and sand in the air.
- Protection to allow outside storage unless the project related Shipping, Packing and Marking Instruction allows otherwise.
- Protection against theft and vandalism.
- Provision for economic lifting, transferring and transport of consignments.
- Strict adherence to international and national laws and regulations for dangerous goods.
- Use of environmentally friendly packaging material capable for recycling.

Dept.	Document No.	Type	Rev. Released	Eng.	Status
1350	HDST601100	DC	MK 2021-12-07	EN	Approved

These requirements are comparable to conditions classified as IE23 of EN 60721-3-2 with regards to transportation and IE14 of EN 60721-3-1 regarding storage.

### 3 Use of ISO Containers

ISO containers are not considered as packaging, but are classified as transport devices.

ISO containers may assist in reducing the measures needed to fulfil above requirements. Refer to the project specific Shipping, Packing and Marking Instruction for further obligations when using containers.

### 4 Packing Protocol and Inspection

#### 4.1 Packing Protocol

The Supplier must issue a packing protocol for each package wherein the adopted packaging and preservation methods are recorded. The test certificate HDST601912 can be used. Alternative forms are permissible but they must at least contain all the information defined in HDST601912.

The Supplier must file/retain all packing protocols for a minimum of 5 years. Within this period, the Supplier is obliged to provide packing protocols upon GE's request.

#### 4.2 Packing Inspection

GE reserves the right to inspect any packing measures at its discretion. The Supplier must cooperate with any requests for inspection and provide the necessary assistance to GE and/or their agents/servants/assigns.

### 5 Dangerous Goods

Parts, components, materials, or products classified by their Safety Data Sheet (SDS) as being dangerous goods must be treated as per applicable regulations (refer to Table 2).

All concerned parts, components, materials, or products must be packed, labelled, marked and declared in strict adherence with the applicable regulations. The Supplier shall be liable for non-compliance to the applicable regulations.

Mode of transport	Governing organisation	Regulation
Road transport	National Government	ADR/SDR <sup>1</sup>
Rail transport		RID/RSD <sup>1</sup>
River transport		ADN <sup>1</sup>
Sea freight	IMO	IMDG-Code
Air freight	IATA/ICAO	IATA-DGR

<sup>1</sup> National and multi-national regulations apply, e.g.

- ADR/SDR in most European countries or
- CFR49 in USA for road transport.
- ADN for European Inland Waterways

Table 2: Codes regulating dangerous goods

### 6 Transport Drawing

The supplier must submit the transport drawing in English language to GE for all packages exceeding 1100 cm in length, 250 cm in width, 300 cm in height and/or 20 tons single weight. And for all packages with a displaced centre of gravity.

The transport drawing must be attached to the product, clearly visible and weatherproof.

This drawing must contain minimum information, such as but not limited to:

- Overall dimension
- Lifting points (location and dimension of such)
- Lashing points (location and dimension of such)
- Support points/areas
- Jacking points (where applicable) (location and dimension of such)
- Handling and lifting instruction
- Weight
- Centre of gravity (in all 3 directions)

Dept.	Document No.	Type	Rev. Released	Lang.	Status
1350	HDST601100	DC	MIK 2021-12-07	EN	Approved

## 7 Marks

All markings must be clearly legible, visibly and indelible. The character height must be at least 30 mm.

### 7.1 Lifting Points

Lifting points of all packages must be marked with the chain symbol as per ISO 780-Figure 16.

### 7.2 Centre of Gravity

Packages with a

- gross weight of 3'000 kg or more,
- a centre of gravity being offset 20% or more compared to the centre line or
- width/height ratio of less than 0.7

must be marked with physically correctly placed symbols for the centre of gravity in accordance with ISO 780-Figure 7. Marking of lighter packages is recommended.

### 7.3 Caution and Handling Marks

Caution and handling marks in accordance with ISO 780 may be added on packages as required.

### 7.4 Shipping Marks

Shipping marks must be carried out exactly as per the detailed directives of the Shipping, Packing and Marking Instruction distributed by the responsible GE Transport Logistics department.

### 7.5 ITNS-I Marks

The following tagging is only applicable on the nuclear related products including ITNS-I.

The purpose is to define and enforce tagging requirements for ITNS-I in accordance with ISO 19443:2018 requirements.

ITNS-I tagging is mandatory only on ITNS-I and shall be done according the below template.



The marking must be in black letters on a yellow background, directly on the packing.

#### 7.5.1 Definition

**ITNS:** Important To Nuclear Safety: characteristic of a product, service, item or activity, whose failure could result in undue radiation exposure of people or the environment. (Source: ISO 19443: 2018)

**ITNS-I:** Important To Nuclear Safety Item: any assembly, component, equipment, material, module, part, software, structure, sub-assembly, sub-system, system or unit:

- Leading to undue radiation in case of malfunction or failure;
- Preventing the malfunction or failure;
- Mitigating the consequences of malfunction or failure.

## 8 Packing List

In case MTA is not used, a packing list must be issued according to the template attached

- The packing list will refer to a GE Project, when applicable
- The packing list will refer to the GE Purchase Order and Line Item
- The packages must be numbered consecutively, including the Purchase Order Number
- The content per package must be clearly listed

Should the order not be complete in one shipment, please indicate on the packing list.

For the remainder of the order, a new packing list must be issued, indicating the next consecutive package number.

One complete packing list inside a watertight envelope must be affixed outside of each package and be covered by sheet metal.

## 9 Packaging Material Requirements

It is the policy of GE to restrict the use of materials and substances in packaging materials that are prohibited, restricted, significant (detrimental) to environment, health or safety, would trigger hazardous waste management requirements or could have a negative impact on end-of-life management.

In general, hazardous, poisonous, toxic, explosive, irritant, harmful, prohibited or restricted materials must not be used in packaging used for shipping GE parts, components, subassemblies, materials or products. Where appropriate any restriction of the country of destination in respect to packaging materials must be respected by the supplier.

The restrictions specified in this section apply to all packaging materials purchased by or on behalf of GE. The requirements apply to all packaging used for shipping GE parts, components, subassemblies, materials or products.

### 9.1 Wood Treatment (ISPM 15)

Any wooden packaging or wooden components of packing must generally be treated per ISPM 15 Standard published by the Commission on Phytosanitary Measures (CPM) on its International Phytosanitary Portal ([www.ippc.int](http://www.ippc.int)), which means that:

- Packaging must be bark-free;
- Packaging must be free from pest infestation; and
- Each individual package must show the conforming marks or must be accompanied by the necessary phytosanitary certificate.

### 9.2 Disposal

The use of packaging materials shall be reduced to a minimum to limit the environmental impact. The applied packaging material shall preferably be recyclable or environmentally sound disposable as governed by local laws and regulation at the receiver's country.

Dept.	Document No.	Type	Rev. Released	Eng.	Status
1350	HDST601100	DC	MIK 2021-12-07	EN	Approved

### 9.3 Restricted Materials

Materials listed in Table 3 must not be used in packaging or means of transportation. In addition to the general policy, all packaging used for shipping GE parts, components, subassemblies, materials or products must not contain:

Asbestos	Asbestos must not be present in packaging materials or transportation means nor in parts, components, materials or products.
Brominated Flame Retardants	Packaging materials must not contain flame-retardants that are polybrominated biphenyls (PBBs) or polybrominated diphenyl ethers (PBDEs), including decabromodiphenyl ether (DecaBDE), also known as polybrominated biphenyl ethers (PBBEs) and polybrominated biphenyl oxides (PBBOs), in concentrations greater than or equal to 0.1% (1000 PPM) by weight in any homogeneous material.
Cadmium, Hexavalent Chromium, Lead, Mercury and its compounds	Packaging materials must not contain lead, mercury, cadmium, or hexavalent chromium where the sum concentration of incidental lead, mercury, cadmium, and hexavalent chromium is greater than 0.01% (100 PPM) by weight.
Chlorinated Hydrocarbons	Chlorinated hydrocarbons must not be contained in any parts, components, materials or products in concentrations greater than or equal to 0.1% (1000 PPM) by weight in any homogeneous material.
Chlorinated Paraffins	Short chain chlorinated paraffins (SCCPs) including, but not limited to those identified by CAS numbers 63449-39-8 and 85535-84-8, must not be used or contained in softeners in paints, coatings and sealants, in oils or in flame-retardants, in rubber, plastic and textiles, in concentrations greater than or equal to 0.1% (1000 PPM) by weight in any homogeneous material.
Formaldehyde	Formaldehyde must not be used in wooden materials, furniture, detergents, cleaning agents and polishes in concentrations greater than or equal to 0.0005% (5 PPM) by weight in any homogeneous material.
Halogenated Diphenyl Methanes	Halogenated diphenyl methanes must not be present in any parts, components, materials, or products in concentrations greater than or equal to 0.1% (1000 PPM) by weight in any homogeneous material.
Lead in Paint	Lead carbonates and sulphates must not be used in any paint applied to parts, components, materials, or products in concentrations greater than 0.01% (100 PPM) by weight in any homogeneous material.
Ozone Depleting Substances (ODS)	Ozone depleted substances must not be used in the manufacturing process of any parts, components, materials or products. This requirement does not apply to use of these substances in refrigeration units used in manufacturing facilities. Ozone depleted substances must not be present in any parts, components, materials or products. Chlorofluorocarbons (CFCs) and hydrochlorofluorocarbons (HCFCs) must not be used in plastic foam packaging materials; for example, as foaming agents.
Polychlorinated Biphenyls (PCBs) and Polychlorinated Terphenyls (PCTs)	Polychlorinated biphenyls (PCBs) and polychlorinated terphenyls (PCTs) must not be present in parts, components, materials or products in concentrations greater than or equal to 0.0005% (5 PPM) by weight in any homogeneous material.
Polychlorinated Naphthalenes	Polychlorinated naphthalenes (more than 3 chlorine atoms) must not be present in parts, components, materials or products in concentrations greater than or equal to 0.0005% (5 PPM) by weight in any homogeneous material.
Radioactive Substances	Radioactive substances must not be present in packaging materials.
Tributyl Tin (TBT), Triphenyl Tin (TPT), Tributyl Tin Oxide (TBTO)	TBTs, TPTs, and TBTOs must not be used in parts, components, materials or products in concentrations greater than or equal to 0.0005% (5 PPM) by weight in any homogeneous material.

Table 3: Materials restricted for packaging

Dept.	Document No.	Type	Rev. Released	Lang.	Status
1350	HDST601100	DC	MK 2021-12-07	EN	Approved



# A Appendix A - Types of Export Packing

This section deals with basic types of export packing.

## A.1 Solid Wooden Boxes

Solid wooden boxes can be considered as the all-purpose outer packing. Care must be taken to use the correct construction type based on the product size and weight. A correctly constructed box also considers widths of lorries and ISO containers.



Deviation!

In opposition to some industry standards, GE prohibits the lining of boxes with tarpaper or similar products.

### A.1.1 Basic Design

#### A.1.1.1 Solid Wooden Box Type 1: Standard Box as per HDST300420

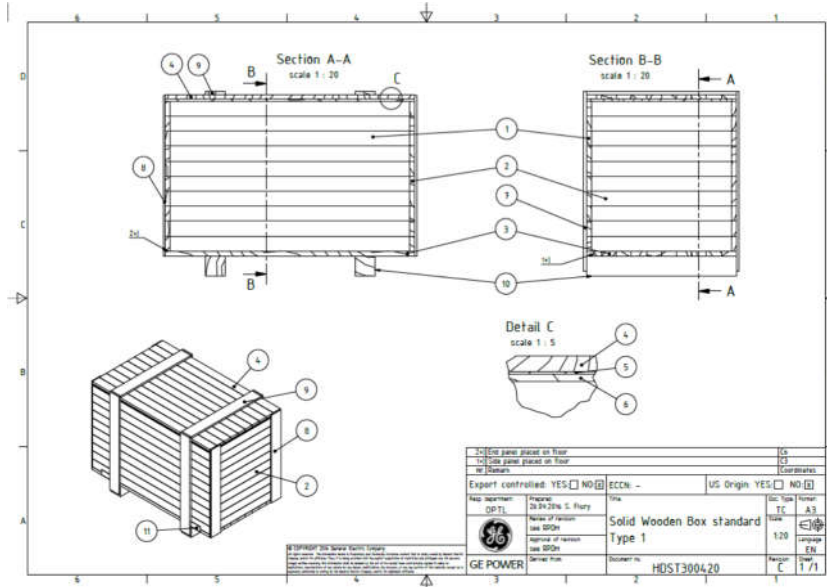

Item	Quantity	Description
1	2	Side wall
2	2	End wall
3	1	Bottom
4	1	Lid
5	1	Waterproof foil
6	1	Internal lid
7	4	Side batten
8	4	End batten
9	2	Lid batten
10	2	Lateral bottom beam
11	4	Sling protection

Figure 1: Solid wooden box type 1

#### A.1.1.2 Large Solid Wooden Box Type 4: Box with Longitudinal Runners as per HDST300421

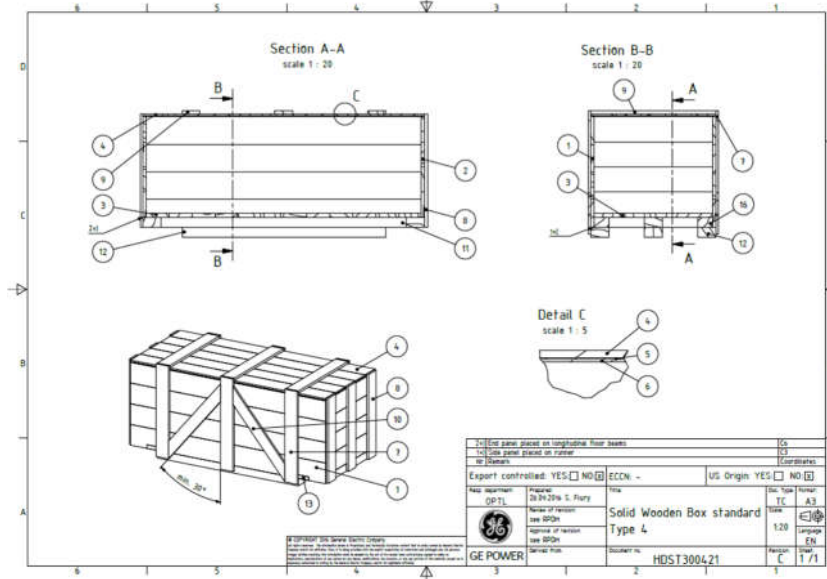

Item	Quantity	Description
1	2	Side wall
2	2	End wall
3	1	Bottom
4	1	Lid
5	1	Waterproof foil
6	1	Internal lid
7	6	Side batten
8	6	End batten
9	3	Lid batten
10	4	Diagonal batten
11	3	Longitudinal bottom beam
12	3	Longitudinal runner
13	4	Sling protection

Figure 2: Solid wooden box type 4

Dept. Document No. 1350 HDST601100  
 Type DC  
 Rev. Released MK 2021-12-07  
 Ling. Status EN Approved



A.1.1.3 Large Solid Wooden Box Type 5: Box with Lateral Runners as per HDST300422

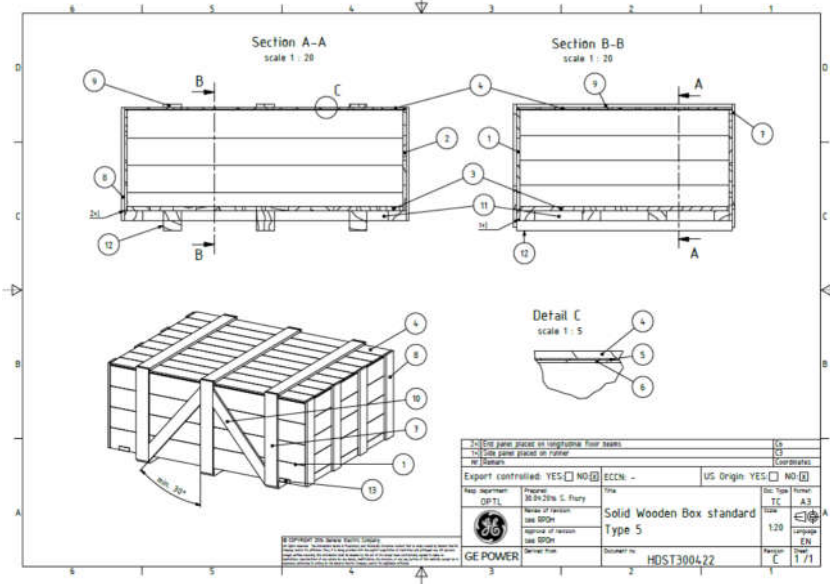

Figure 3: Solid wooden box type 5

A.1.1.4 Large Solid Wooden Box Type 6: Box with Lateral Bottom Beams as per HDST300423

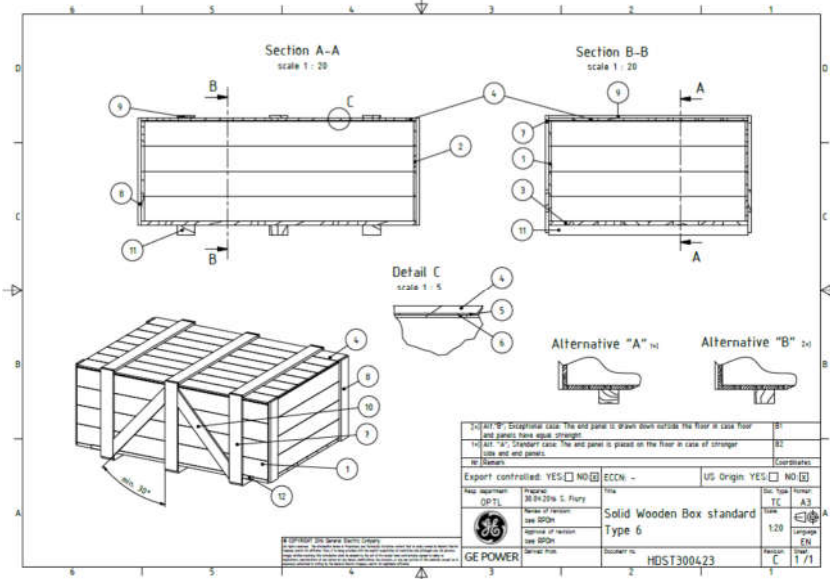

Figure 4: Solid wooden box type 6

Dept.	Document No.	Type	Rev. Released	Eng.	Status
1350	HDST601100	DC	MK 2021-12-07	EN	Approved





## A.1.2 Specification

### A.1.2.1 Material

Materials to be used for solid wooden boxes are semi dry fir, spruce or pine of grade class S 7/MS 7 for boards and S 10/ MS 10 for battens, planks and joists and beams as per DIN 4074-1.

### A.1.2.2 Guidelines Determining the Thickness of Wooden Package Components

Box capacity [kg]	Wood thickness [mm] Side/end			Remarks
	Bottom	Walls	Lid	
100 - 2'000	24	18	18	Select the appropriate combination per chart and depending on box content (single lightweight object / single heavyweight object, bulk material, etc.). If in doubt, select next higher box capacity level. <sup>1</sup> Thickness may be increased for large box widths
2'000 - 9'000	30	24	24 <sup>1</sup>	
9'000 - 18'000	40	30	24 <sup>1</sup>	
18'000 - 30'000	50	30	24 <sup>1</sup>	

Table 4: Size of package components for solid wooden boxes

### A.1.2.3 Construction

For construction details refer to section A.6.

Dept.	Document No.	Type	Rev. Released	Lang.	Status
1350	HDST601100	DC	MK 2021-12-07	EN	Approved



### A.2 Plywood Boxes

Whenever possible use plywood for box sizes up to 2'350 x 1'100x 2'800 mm (L x W x H) as far as the net weight allows for it.

#### A.2.1 Basic Design

Applicable for net weights up to 500 kg and 1'500 kg respectively.

##### A.2.1.1 Plywood Box Type 7: For Net Weights up to 500 kg as per HDST300482



Deviation!

In opposition to some industry standards, GE prohibits the lining of boxes with tarpaper or similar products.

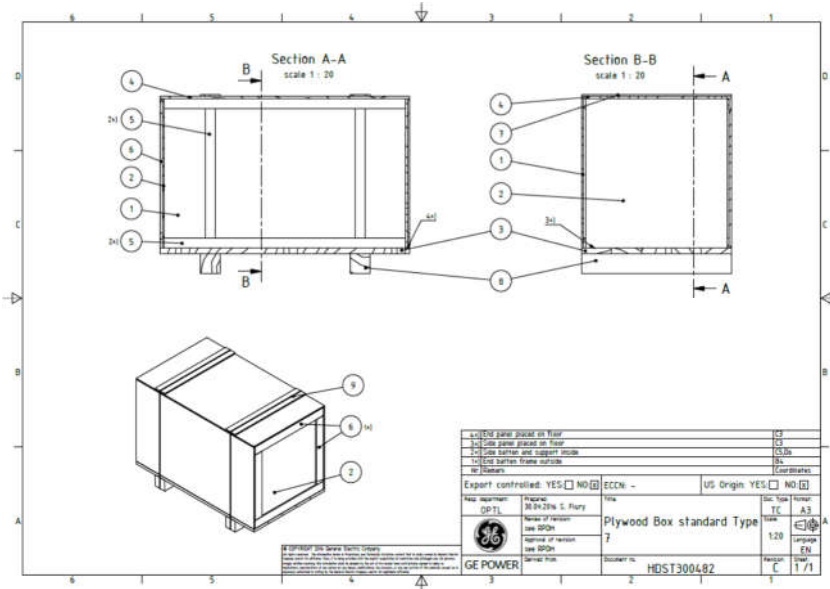

Item	Quantity	Description
1	2	Side wall
2	2	End wall
3	1	Bottom <sup>1</sup>
4	1	Lid
5	8	Side batten <sup>1</sup>
6	8	End batten <sup>1</sup>
7	2	Lid batten <sup>1</sup>
8	2	Lateral bottom beam <sup>1</sup>
9	2	Metal straps

<sup>1</sup> made of solid wood

Dept.	Document No.	Type	Rev. Released	Eng.	Status
1350	HDST601100	DC	MK 2021-12-07	EN	Approved

Figure 5: Plywood box type 7

##### A.2.1.2 Plywood Box Type 8: For Net Weights up to 1'500 kg as per HDST300503

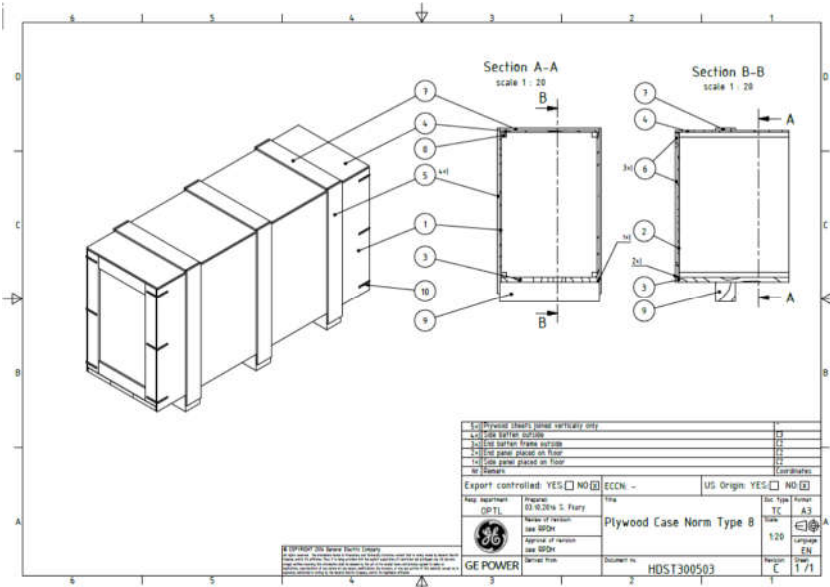

Item	Quantity	Description
1	2	Side wall
2	2	End wall
3	1	Bottom <sup>1</sup>
4	1	Lid
5	6	Side batten <sup>1</sup>
6	8	End batten <sup>1</sup>
7	3	Lid batten <sup>1</sup>
8	4	Longitudinal reinforcement <sup>1</sup>
9	3	Lateral bottom beam <sup>1</sup>
10	12	Edge binder (metal)

<sup>1</sup> made of solid wood

Figure 6: Plywood box type 8

## A.2.2 Specification

### A.2.2.1 Material

Materials to be used for plywood components of the box are defined in DIN 68705-3 or EN 13986. BFU 100 type plywood panels are glued with phenol resin and are therefore heat-resistant and waterproof.

Materials to be used for solid wooden components of the box are semi dry fir, spruce or pine of grade class S 7/MS 7 for boards and S 10/ MS 10 for battens, planks and joists and beams as per DIN 4074-1.

### A.2.2.2 Guidelines Determining the Thickness of Wooden Package Components

Box capacity [kg]	Wood thickness [mm] Side/end			Remarks
	Bottom	Walls	Lid	
100 - 1'000	24	12	12	Select the appropriate combination per chart and depending on box content (single lightweight object / single heavyweight object, bulk material, etc.). If in doubt, select next higher box capacity level.
1'000 - 1'500	30	16	16	

Table 5: Size of package components for plywood boxes

### A.2.2.3 Construction

#### General

- For bottom construction refer to section A.6.1.
- For fastening, securing, and padding refer to A.6.2
- Lid and end walls must be constructed from a single plywood sheet.
- To ensure drain and ventilation do not use plywood for the box bottom.

#### Boxes for net weight up to 500 kg

- End walls must be equipped with batten frames outside.
- Side walls must be carried out with battens and supports inside.
- Plywood boxes must always be tied with two metal or plastic straps.

#### Boxes for net weight up to 1'500 kg

- End walls must be equipped with batten frames of minimum 120 mm width outside.
- Plywood sheets of the side wall may only be vertically connected.

#### Boxes for heavier net weights

The inner box construction must be adapted to bear all loads due to stacking and sling compression. Refer to section A.6.6.

## A.2.3 Alternative Plywood Box Designs

Standard folding boxes may be used instead of the plywood boxes mentioned above.

The Supplier shall be responsible for the correct selection and application of any alternative designs to meet the minimum requirements as per section 2.

### A.3 Crates

Crates are used whenever the external shape of the product constricts or even hinders loading, transferring or other manipulations. Products packed in crates must be insensitive to corrosion and environmental factors.

#### A.3.1 Basic Design

##### A.3.1.1 Solid Wooden Crate Type 1 (Open Lid) and 2 (Closed Lid) as per HDST300404

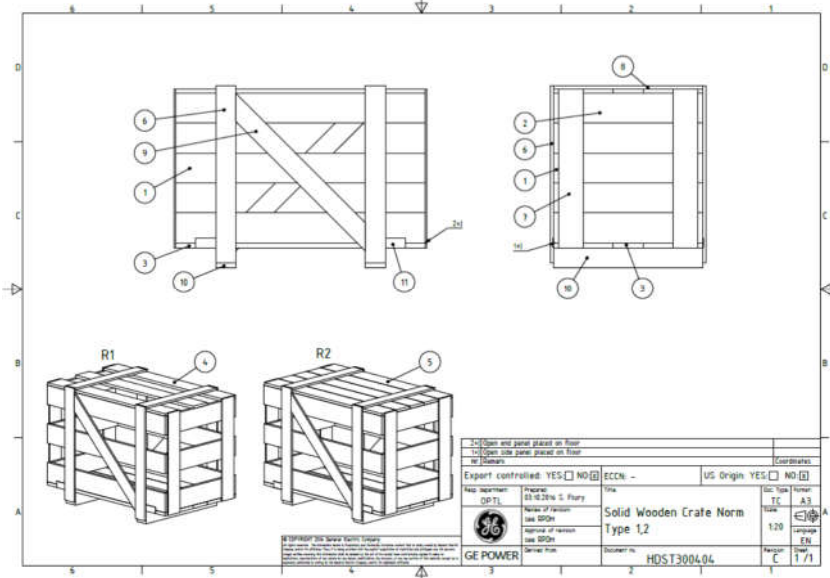

Figure 7: Solid wooden crate type 1 and 2

##### A.3.1.2 Large Solid Wooden Crate Type 3: Crate with Lateral Bottom Beams as per HDST300405

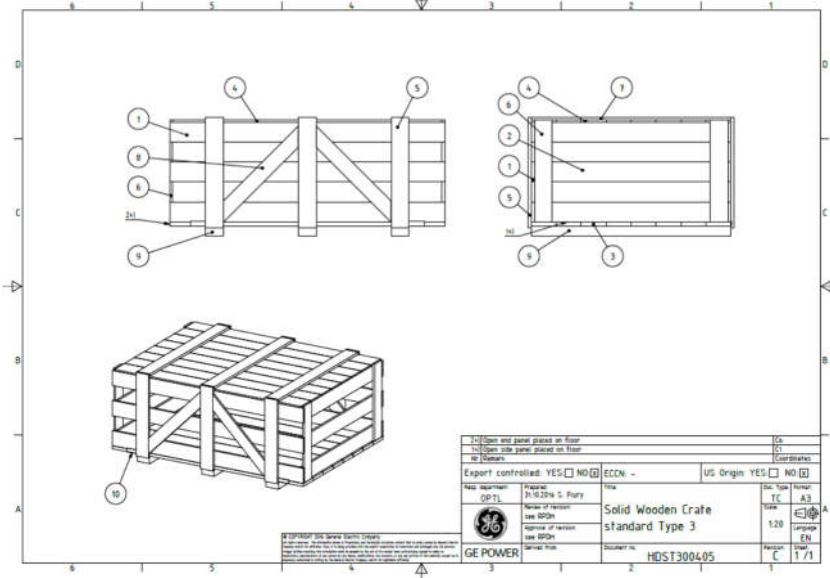

Figure 8: Solid wooden crate type 3

Dept. Document No. 1350 HDST601100  
 Type DC  
 Rev. Released MK 2021-12-07  
 Ling. Status EN Approved

### A.3.2 Specification

#### A.3.2.1 Materials

Materials to be used for crates are semi dry fir, spruce or pine of quality grade class S 7/MS 7 for boards and S 10/ MS 10 for battens, planks and joists and beams as per DIN 4074-1.

#### A.3.2.2 Guidelines for Determining of Thickness of Wooden Package Components

Box capacity [kg]	Wood thickness [mm] Side/end			Remarks
	Bottom	Walls	Lid	
100 - 2'000	24	18	18	Select the appropriate combination per chart and depending on box content (single lightweight object / single heavyweight object, bulk material, etc.). If in doubt, select next higher box capacity level. <sup>1</sup> Thickness may be increased for large box widths
2'000 - 9'000	30	24	24 <sup>1</sup>	
9'000 - 18'000	40	30	24 <sup>1</sup>	
18'000 - 30'000	50	30	24 <sup>1</sup>	

Table 6: Size of package components for solid wooden crates

#### A.3.2.3 Construction

For construction details refer to section A.6.

## A.4 Corrugated Cardboard Boxes

Cardboard boxes are applicable for net weights of up to 300 kg depending on quality grade and the use of suitable inner packing.

Corrugated cardboard boxes are offered in three quality grades, i.e. single, double or triple fluted (Figure 9), which define their application.

Boxes are not suitable for multi modal transport of heavy machinery products and must therefore not be used for sea freight and rail transport.

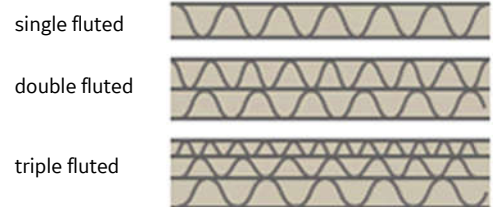

Figure 9: Composition of corrugated cardboard

#### A.4.1 Pre-Packing

Double and triple fluted boxes may be used for pre-packing of parts and products, which are consolidated in a wooden box, ISO container or triple fluted box. It is however essential to prevent condensation and moisture penetration, which diminishes the strength of boxes.

#### A.4.2 Postal deliveries

Postal deliveries in double fluted boxes are only suitable for mainland transports. Worldwide deliveries must be packed in triple fluted boxes.

#### A.4.3 Intermediate storage

Cardboard boxes, irrespective of their quality, must not be used for road and air transport if intermediate storage is anticipated. Note that cardboard boxes are not suitable for outside storage. Hence, the use of boxes for outer packing is basically limited to express deliveries with limited intermediate handling.

Application	Single fluted	Double fluted	Triple fluted
Pre-packaging	✗	✓ <sup>1</sup>	✓
Postal delivery	✗	✓ <sup>1</sup>	✓
Road transport	✗	✓ <sup>2</sup>	✓ <sup>2</sup>
Rail transport	✗	✗	✗
Sea freight	✗	✗	✗
Air freight	✗	✗	✓ <sup>2</sup>

<sup>1</sup> Mainland transports only

<sup>2</sup> Not suitable whenever intermediate storage is anticipated

Table 7: Use of cardboard boxes



### A.5 Bundles

Bundles are transport or packaging units where the packaging effort is limited to joining several parts to make them transportable, secure, stackable and fit to be lifted by cranes and industrial trucks.

Products may only be bundled when they themselves can bear the stack compression loads without additional support and when they do not bend or dent.

The use of wire, steel or textile strapping on their own is not permitted since this type of bundling is unable to keep a rigid shape.

Clamps of bolted timber or, for higher net weights, sectional steel clamps with timber inserts must be used. Clamps must be firmly locked so that the products cannot slide out of the bundle even if handled off-horizontal. This must be guaranteed even after repeated transshipment and prolonged storage.

A bundle must be held together by at least three clamps. The squared timbers/steel clamps used must be able to withstand expected loads. The lateral projection of timber/steel clamps (over the product width) to hold the locking bolts must be at least 10 cm each side. The thickness of the locking bolts must not be less than 12 mm in diameter.

Washers must be placed under the nuts and ends of the lock bolts in compliance with DIN 436 or ISO 7094. Nuts are to be secured against loosening. Projecting bolts must be shortened to the required length after tightening.

Timber battens (for loading and stacking) must be nailed to the timber clamps or timber inserts between the locking bolts. The height must be sufficient to afford protection to the remaining locking bolts.

Intermediate layers, if required, must be made of weatherproof plywood. The clamps must also retain marking areas or end planking.

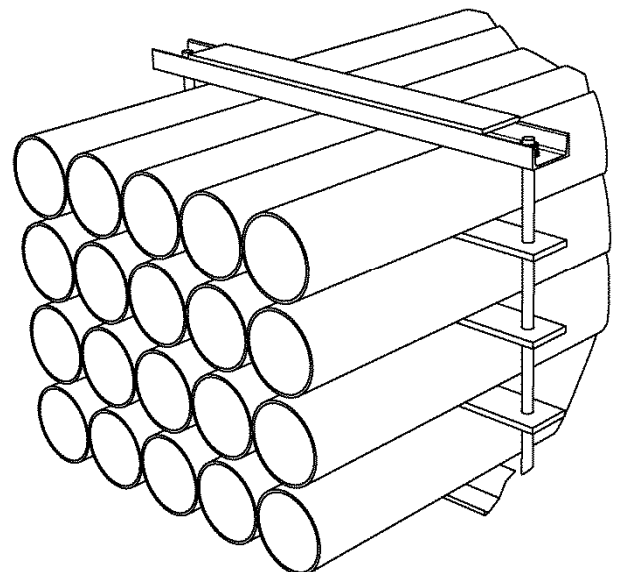
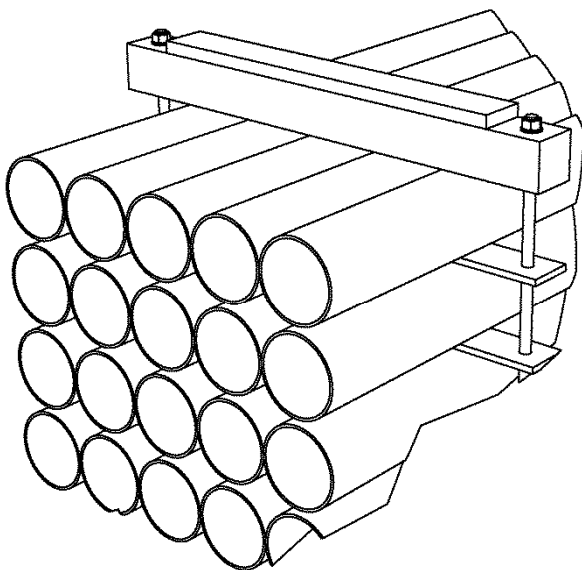
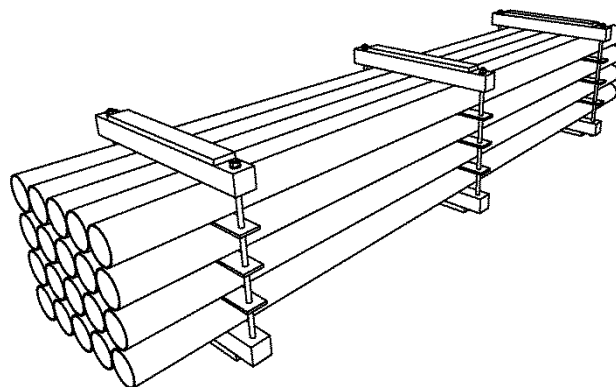

Figure 10: Bundles having clamps made of squared timbers or sectional steel

Dept.	Document No.	Type	Rev. Released	Eng.	Status
1350	HDST601100	DC	MK 2021-12-07	EN	Approved



### A.6 Packaging Construction

Any packaging must be capable to withstand the loads as shown in Table 8, which may occur during transport and storage.

#### A.6.1 Bottom Design

##### A.6.1.1 Basic Principles

The most important component of every box is the bottom. The box bottom absorbs all forces of the packaged product, the walls and the lid, and any loads stowed on top during transport, handling and storage. For this reason, importance must be placed on a technically proper design of this component. The basis for calculation is HDST601042.

The following principles must always be observed:

- Depending on the requirements, size and weight, the bottom must be provided with lifting possibilities for cranes and forklifts in accordance with the package's centre of gravity.
- Packaged products must be secured to the bottom of the box so that shifting is not possible. Whenever possible, direct bolt connection to the packaged product must be provided. If this is not possible, forces must be absorbed via continuously bolted frames, lateral or longitudinal timbers.
- The packaged product weight must be distributed uniformly over the entire surface of the bottom. If necessary, this must be realised with supports on the packaged product. If this is not possible, the bottom design must be adjusted to the available contact surface.
- Bolt connections which absorb axial forces must be dimensioned in accordance with the occurring forces. The use of so-called bulldogs is only permissible when it can be ensured that they penetrate completely into the wood and no gap remains between wooden members.
- All bolt connections must be provided with washers. These must be dimensioned so that the diameter of the washer is at least 2.5 times the diameter of the hole.
- Washers of bolt connections with tensile load must be replaced with steel plates for stabilisation. These must be dimensioned so that the entire tensile loads are transferred without deformation of the steel plate.
- To avoid corrosion triggered by wood acid, any direct contact between wood and metal must be prevented. Contact surfaces must be separated by a chemically neutral layer (e.g. PE foil).

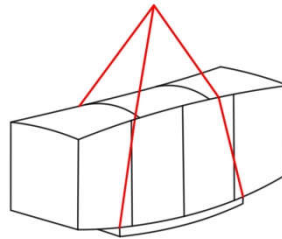

1. Bending loads of bottom during crane handling
2. Lateral cable pressure on bottom side walls and lid

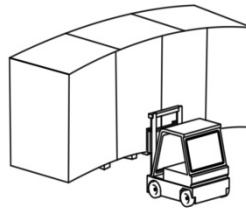

3. Bending loads during forklift handling

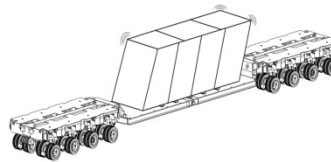

4. Loads in longitudinal, lateral and vertical direction

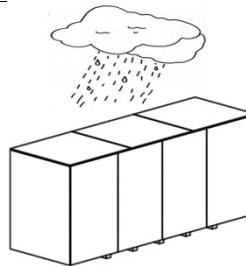

5. Weathering

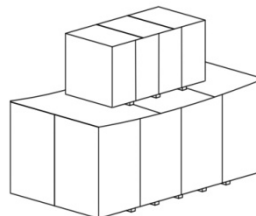

6. Stacking pressure

Table 8: Loads on packaging during transport and storage

Dept.	Document No.	Type	Rev. Released	Eng.	Status
1350	HDST601100	DC	MIK 2021-12-07	EN	Approved



A.6.1.2 Composition

The bottom design can be carried out in different ways. However, each design must meet the requirements of the packaged product and absorb and dissipate the resulting forces in the best possible manner. It is preferable to cause direct load dissipation without or the least possible a bending moment. For this purpose, the cross-sections can be reduced and the required wood remains in a useful and reasonable range.

A.6.1.3 Bottom Elements

The beams (Figure 11, Item 1) must always be aligned in longitudinal box direction. Depending on the condition of the packaged product, the sling battens (Item 2 and 3) can be attached in the longitudinal or the lateral direction. The sling battens can protrude in the width of wall board thickness X (Figure 12) over the bottom design in the lateral (box width) and/or longitudinal (box length) direction to

- enable simpler mounting of the side walls; and
- better absorb vertical forces on the box (stacking pressures etc.).

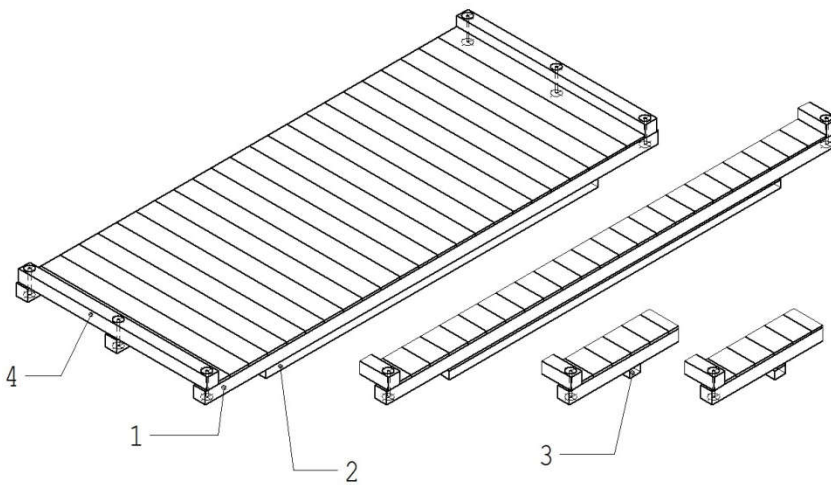

Item	Description
1	Longitudinal beam
2	Longitudinal sling batten
3	Lateral sling batten
4	Bolted header beam

Dept.	Document No.	Type	Rev. Released	Lang.	Status
1350	HDST601100	DC	MK 2021-12-07	EN	Approved

Figure 11: Bottom elements

It is important that the axial forces are absorbed via continuous bolt connections through the longitudinal and header beams. The header beams must have at least the same cross-section as the longitudinal beams. The design shown in (Figure 12) can be equipped with as many longitudinal beams as required.

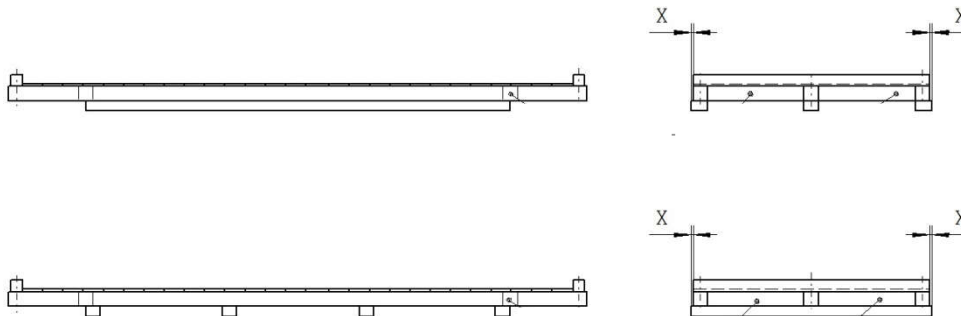

Figure 12: Skid protrusion X





Moreover, it must be ensured that sling pressure timbers, beams with the same cross-section as the longitudinal beams, are installed between the longitudinal beams around the slinging points for the absorption of lateral running sling pressure (Figure 13). The sling pressure timbers are to be installed with both longitudinal and lateral sling battens. This must be considered for all bottom designs for which increased loads may occur due to the weight or the box width.

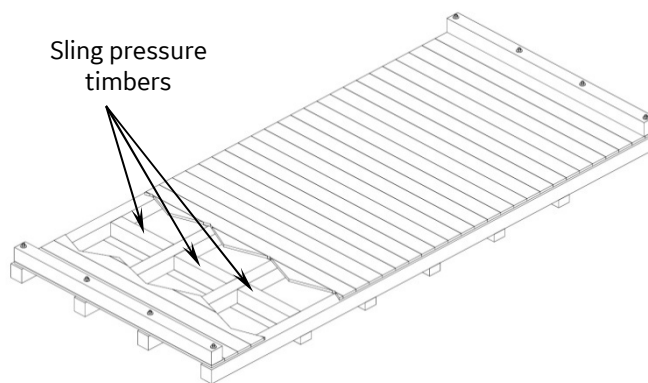

Figure 13: Sling pressure timbers as a part of the bottom design

The slinging points on the bottom of the box and at the transition from the box wall to the lid must be provided with corresponding sling protection profiles in accordance with A.6.8.

#### A.6.1.4 Boxes with overall width greater than 2'500 mm

For boxes with a width of 2'500 mm or more, the following recommendation applies:

Due to the limited contact surface on vehicles, a design with sling battens in lateral direction must be provided. This considerably increases the stability of the package on the vehicle.

If the design of the packaged product does not permit a bottom design with lateral sling battens, then the hollow cavities between the longitudinal beams must be lined with wooden beams with cross-sections identical to those of the longitudinal beams. Thus, the same stability can be ensured on the vehicle as with a box bottom with lateral sling battens.

### A.6.2 Fixation and Bracing of Packaged Products

#### A.6.2.1 Types of Fixations and Bracings

The packaged product must be secured against forces which occur during transport. This can be carried out in various ways:

- Bolting of the product directly to the bottom of the box.
- Bracing on the bottom of the box without direct bolting.
- Bracing via bearing points (attachment points of the box).
- Bracing of the product via box walls to secure against tipping and uplift

#### A.6.2.2 Direct Bolting to Box Bottom

Bolting particularly heavy products to load bearing bottom support members should be considered as the safest and best method. Foundation anchor bores may often be used to do so. Rubber mats must be used to ensure the sealing (Figure 14), when combining this fixation method with the desiccant preservation method (refer to B.2).

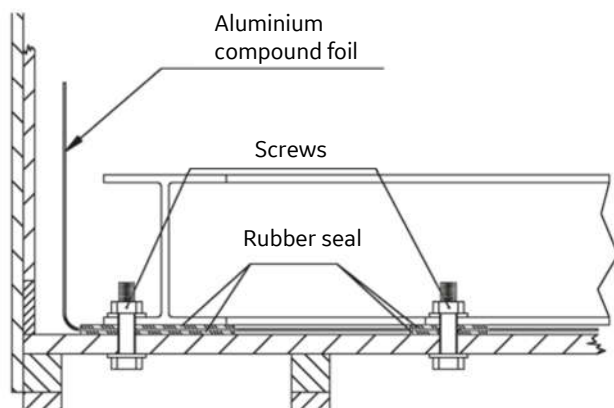

Figure 14: Foil sealing of bolted connections

Dept.	Document No.	Type	Rev. Released	Eng.	Status
1350	HDST601100	DC	MK 2021-12-07	EN	Approved



### A.6.2.3 Bracing Without Direct Bolting

When bracing without direct bolting, the packaged product must be fixed in longitudinal direction with squared timbers. The design is based on the type of packaged product. Bolt connections which must absorb axial loading must be carried out with washers in accordance with section A.6.1.1. The bracing must always be supported on the header beam (Figure 15, Figure 16).

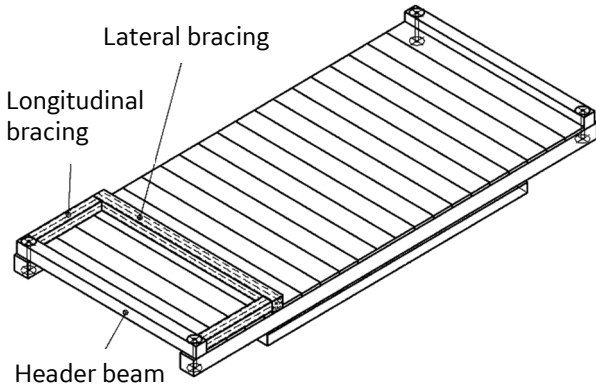

Figure 15: Structure of bracing without direct bolting

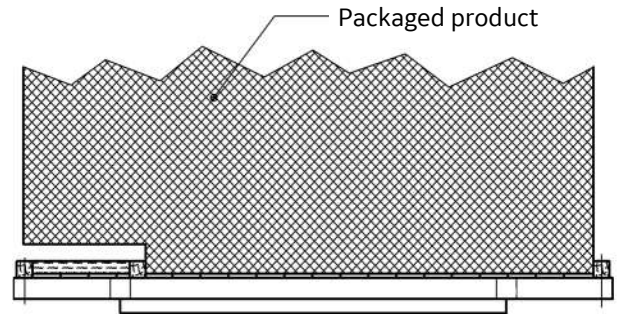

Figure 16: Longitudinally braced packaged product

### A.6.2.4 Bracing with Supporting Squared Timber

The condition of the product, the weight, the geometry and the bracing possibilities may require one of the bracing types with aslope supporting beams described below. In this case, it must be ensured that this supporting squared timbers are positioned upright on the bottom at the height of the sling battens (Figure 18) and that the bracing is installed under a maximum angle of 45° to ensure an optimized flow of force on the header beams. The quantity and location of the timbers depends on the horizontal force transmission of the packaged product (Figure 19).

The timbers lying laterally on the supporting squared timber must be firmly bolted to the support.

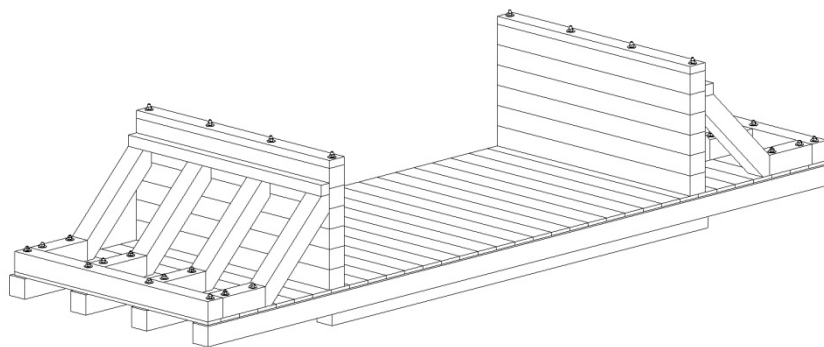

Figure 17: Bottom design with supports and supporting beams

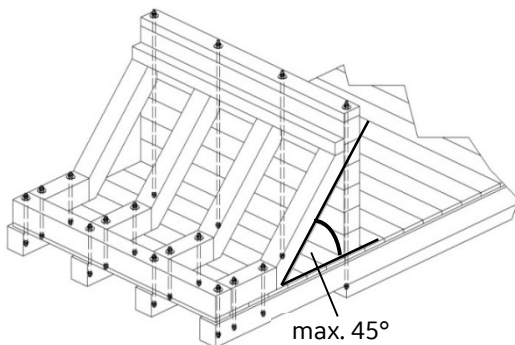

Figure 18: Maximum angle of supporting timbers

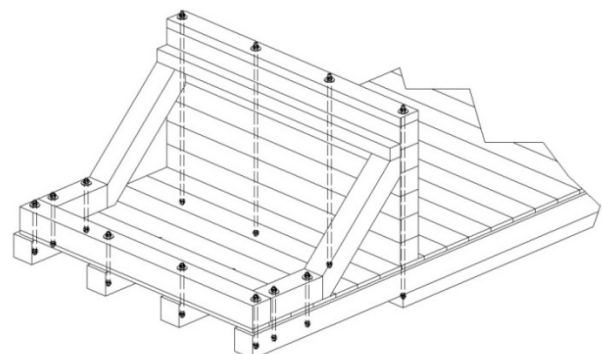

Figure 19: Quantity and location depend on packaged product

Dept.	Document No.	Type	Rev. Released	Eng.	Status
1350	HDST601100	DC	MK 2021-12-07	EN	Approved



### A.6.2.5 Bracing via Box Walls

Bracing to fixate the product within the box shall only be connected to the box walls. Bracing must never be attached directly to the lid as such design would transfer stacking loads onto the product, resulting in damage.

### A.6.3 Walls

To ensure that the walls solidity, to increase the strength of the box design and to optimally route the stacking pressure forces into the bottom of the box, the box walls must be equipped with a batten framework. This includes lateral, longitudinal, vertical and diagonal battens (Figure 20).

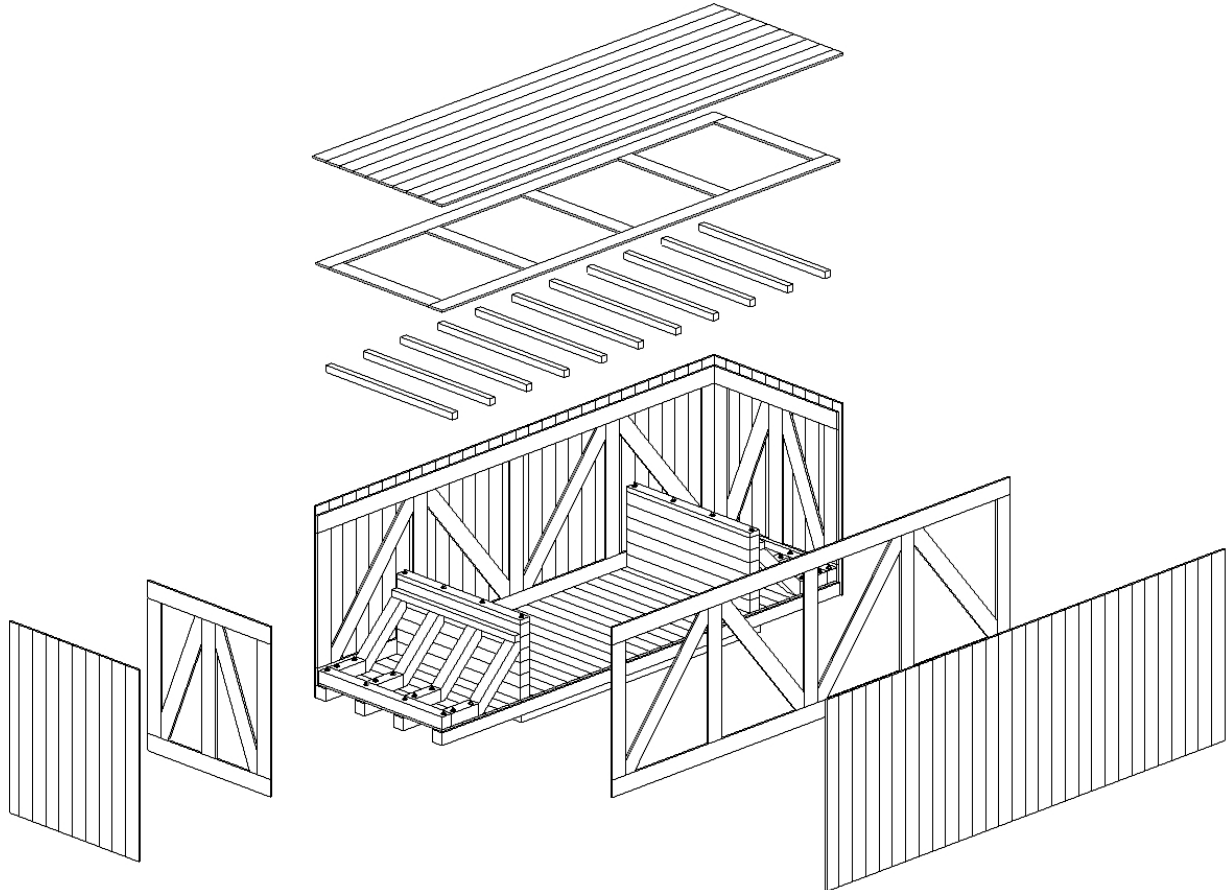

Figure 20: Composition of box walls

The thickness of the framework used on the inside of the box must be adjusted depending on the weight and size of the box. The basis for calculation is HDST601042. The lid-support members (lid beams) can be laid on the upper longitudinal batten of the side walls. Thus, the outside boarding (horizontal/vertical) of the box wall absorbs a large part of the stacking forces.

Dept.	Document No.	Type	Rev. Released	Eng.	Status
1350	HDST601100	DC	MK 2021-12-07	EN	Approved



### A.6.4 Lid-Support Members and Vertical Lid Supports

Lid-support members and lid supports are the elements absorbing the stacking pressure. They must be distributed evenly over the entire length of the box and must be dimensioned so that an evenly distributed assumed surface load of 1 t/m<sup>2</sup> can be absorbed.

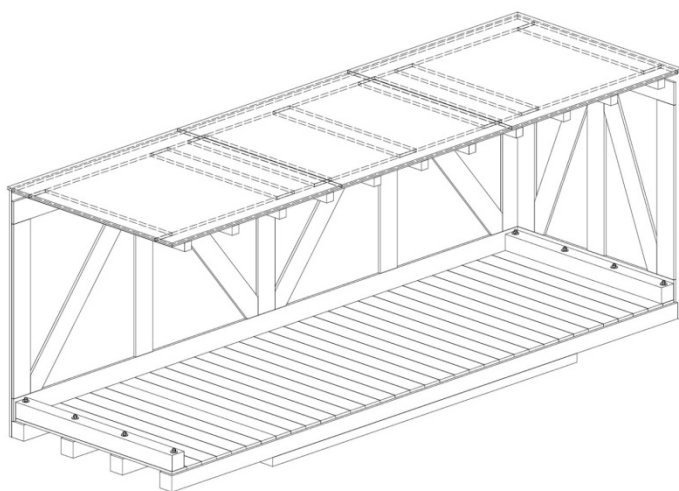

Figure 21: Lid-support members laid on the framework

Additional lid beams can be inserted for reinforcement around the slinging points.

If the box wall is equipped with a sufficiently strong framework on the inside, the lid-support timbers can be laid on the framework (Figure 21). In this case, an appropriately dimensioned framework must be ensured so that the surface pressure does not cause structural damage to the framework.

Should the loads be too high, vertical supports must be provided below the lid-support members, which support the side walls when transferring the stacking compression forces.

The cross-sections are to be dimensioned in accordance with HDST601042 against bending, compression and buckling.

### A.6.5 Rain Protection Lid

All boxes must be equipped with a rain protection lid. This lid is intended to prevent water from penetrating into the box from above. The design can be carried out with sandwich panels or a combination of PE-foil and with plywood panels.

When using sandwich panels, they must be attached under the entire box lid without any separating edges. The ends must overlap by at least 30 cm and must be sealed off with adhesive tape if it is not possible to attach one sandwich panels without separating edges due to the dimensions of the lid.

Depending on the supplier, sandwich panels (Figure 22) are offered in various dimensions and web thicknesses. The minimum thickness is 2.5 mm.

When fabricating a rain protection lid using PE foil (Figure 23), it must always be ensured that the foil is lined towards the inside with a plywood panel as otherwise formation of water pouches can occur. If this pouch filled with water bursts, the water running down can tear the corrosion protection foil, resulting in damage to the packaged product.

Dept.	Document No.	Type	Rev. Released	Lang.	Status
1350	HDST601100	DC	MK 2021-12-07	EN	Approved

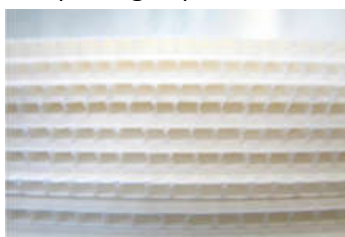

Figure 22: Sandwich panels

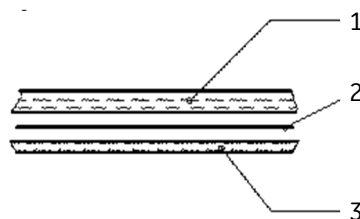

Figure 23: Composition of rain protection lid using PE foil

Item	Description
1	Box lid
2	PE-foil
3	Plywood lining



## A.6.6 Outer Boarding

The outer cladding of boxes can be produced from a broad range of materials.

However, the basic requirement is a statically correct supporting structure on the inside of the box so that all forces acting on the packaged product can be absorbed and dissipated.

### A.6.6.1 Sawn Timber

#### Vertical and Horizontal Boarding

With all boxes of sawn wood, the wood must be arranged so that its properties are optimally utilised. The vertical boarding of the side and end walls results in at least partial absorption of the vertical forces and the stacking pressure.

A horizontal arrangement is only advisable for small boxes (approx. 1 m<sup>3</sup>) or if the box length is 8 times longer than box height. With long boxes, the contribution to the absorption of the stacking pressure tends to be minimal; however, the focus shifts to a contribution of the absorption of the bending load.

### A.6.6.2 Plywood

Box cladding made of water resistant glued plywood is subject to the same loads as boxes constructed from boards. As a result of the of the usually thinner wall thickness, the load-bearing capacity must be ensured with the supporting structure.

With plywood boxes, it must be ensured that abutting edges are always covered with wooden battens to prevent the penetration of water. Also, plywood boxes must be equipped with a rain protection lid. Plywood may not be used for the bottom of the box, as the ventilation of the box is not ensured anymore. The only exception to this are so-called "folding boxes" for volumes of up to 1 m<sup>3</sup>.

Plywood panels used for outer boarding of a box must have a minimum thickness of 12 mm. Here as well, exceptions to this are folding boxes.

Dept.	Document No.	Type	Rev. Released	Lang.	Status
1350	HDST601100	DC	MK 2021-12-07	EN	Approved

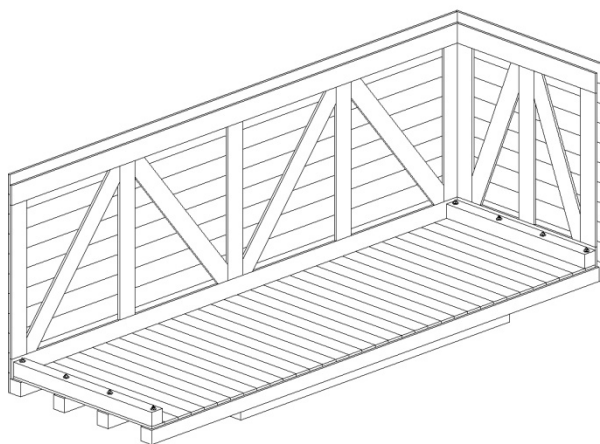

Figure 24: Box with horizontal saw wood boarding

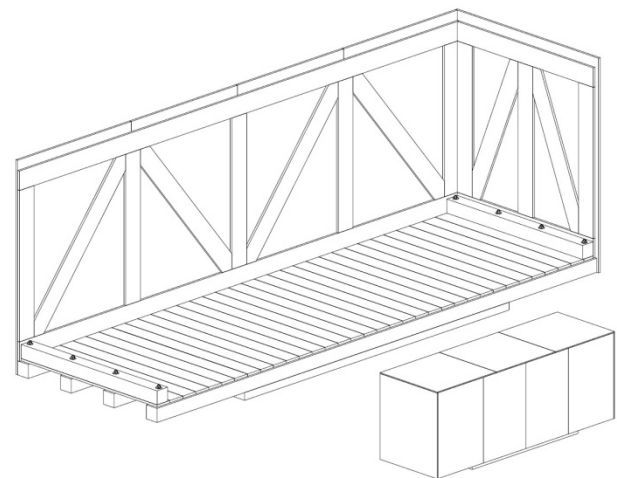

Figure 25: Box cladding made of plywood panels

### A.6.6.3 OSB Panels

With the low priced OSB panels (oriented strand board) long slim strands are pressed and glued under high pressure and at high temperature. OSB needs to be checked for potential formaldehyde evaporation (refer to 9.3 Restricted Materials) depending on used adhesive. No fibre direction can be determined as with multi-layer plywood since strands are not interconnected. Hence, OSB panels do not offer the same load-bearing capacity as plywood or solid wood due to the material structure.

OSB panels of the classes OSB/1 and OSB/2 as per EN 300 swell up when exposed to water and therefore lose any load-bearing capacity, which makes them unsuitable for use as packaging material.



### A.6.7 Crates

With crates the inside structure remains unchanged. The wall boarding however is not closed. Some boards are omitted. Depending on the nature of packaged product either a design with closed or partially open lid can be selected.

### A.6.8 Fittings

Lifting of heavy boxes or crates by means of cable slings often used in ports, may damage the package to such an extent that it loses its strength and/or capability to protect the product. Therefore, boxes and crates exceeding 5 tonnes gross weight must be equipped with sling protections and slide strips.

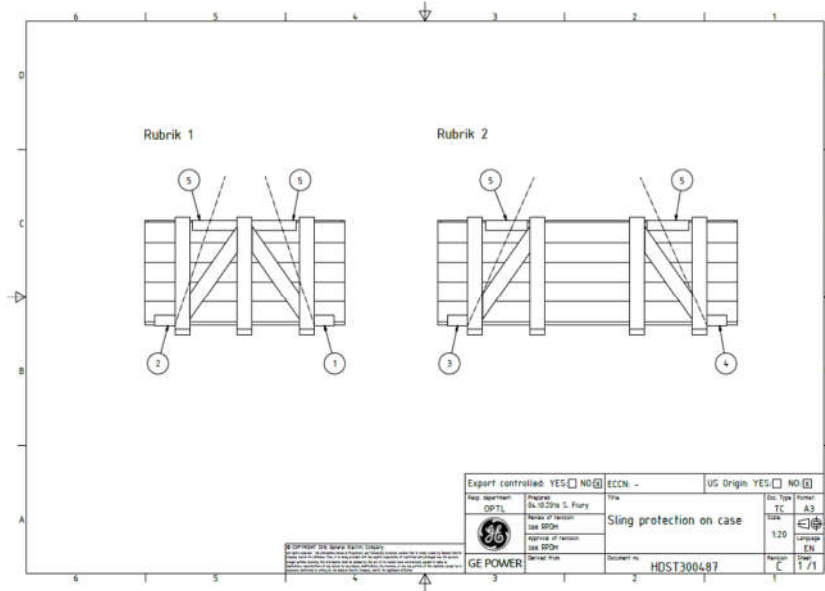

Dept.	Document No.	Type	Rev.	Released	Lang.	Status
1350	HDST601100	DC	MK	2021-12-07	EN	Approved

Figure 26: Fittings for box protection

#### A.6.8.1 Sling protections

The lifting points of boxes or crates must be equipped with sling protections suitable to the respective package gross weight.

Alternative protections, other than the following described models may be used as long as they are of satisfactory design and are approved by GE Transport Logistics.

Light design: 5 to 20 t as per HDST301284

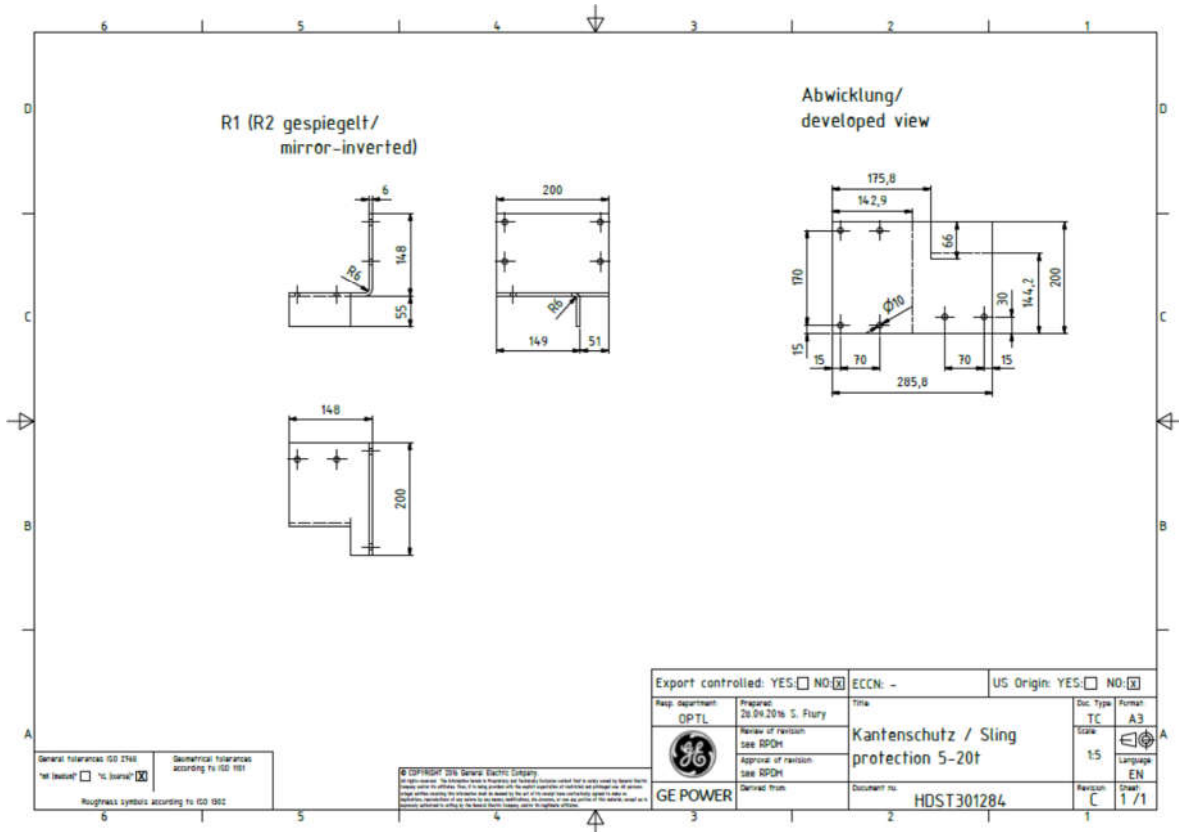

Figure 27: Sling protection 5 to 20 tonnes

Heavy design: 20 to 50 t as per HDST301283

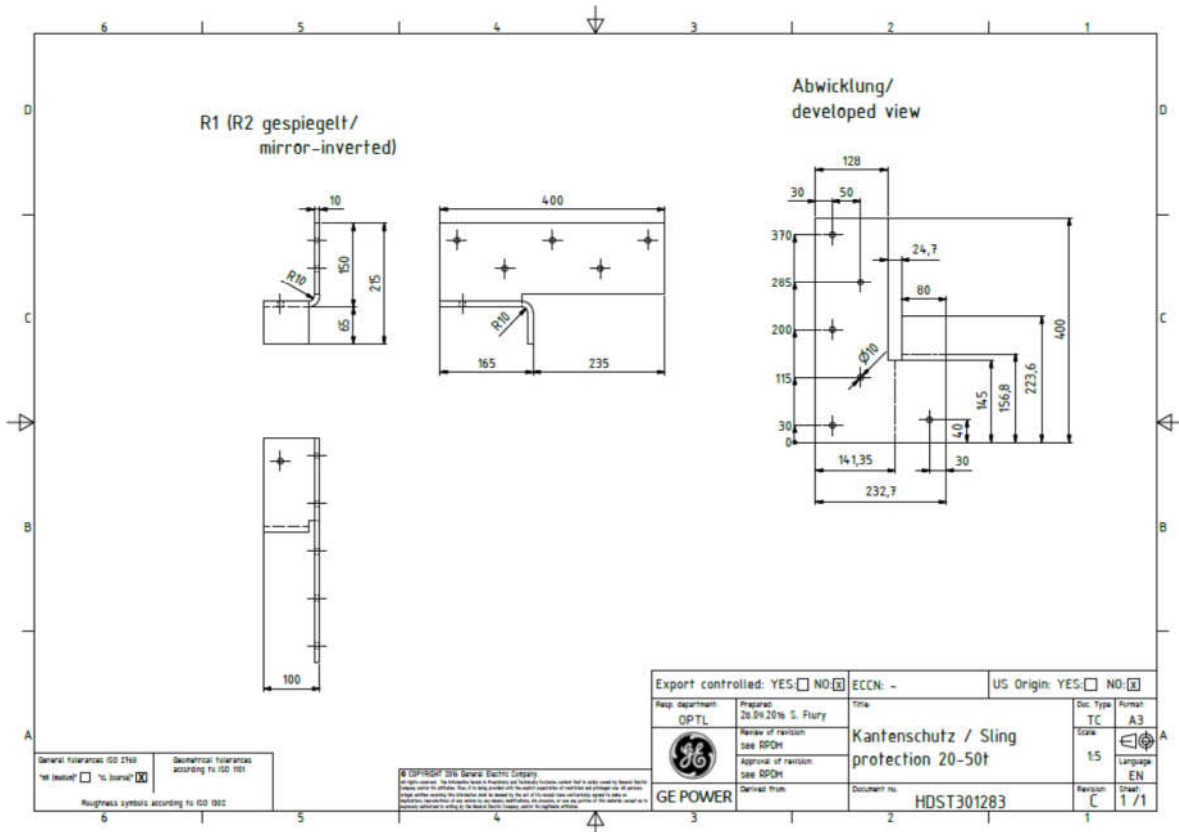

Figure 28: Sling protection 20 to 50 tonnes



Heavy duty design: More than 50 t as per HDST303538

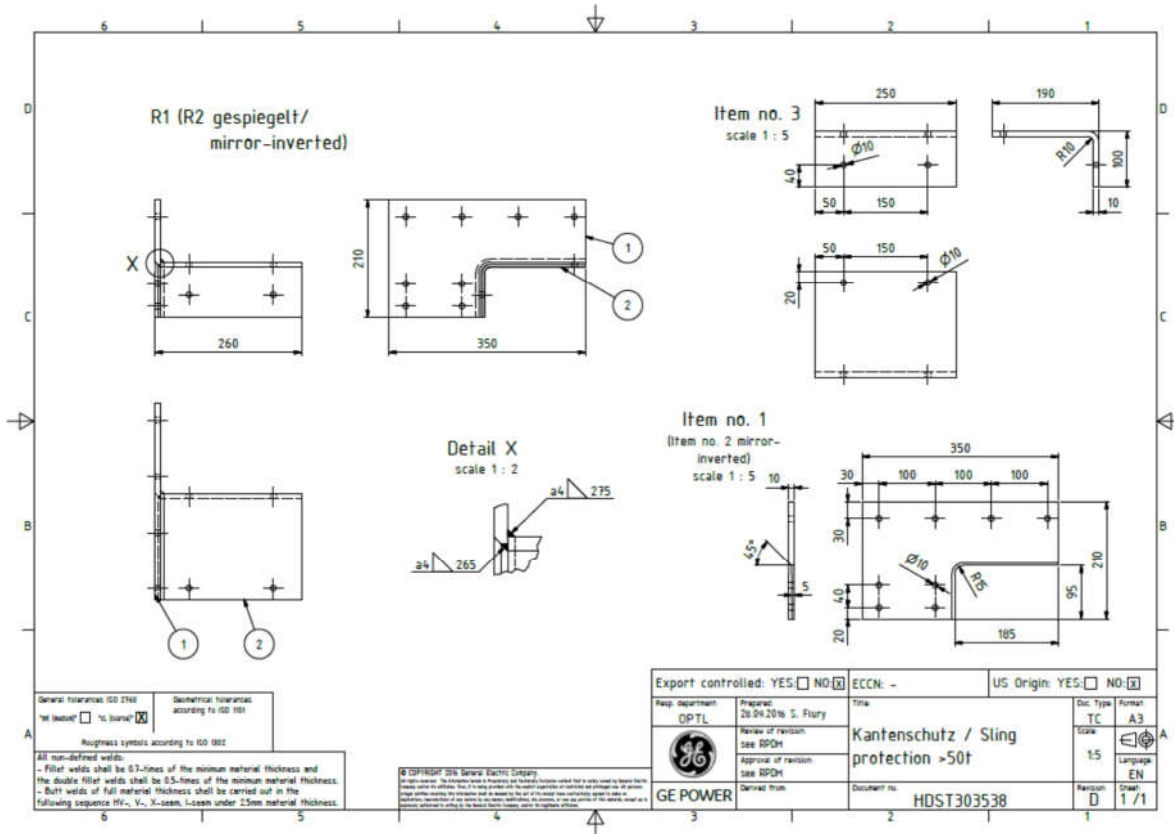

Figure 29: Sling protection for more than 50 tonnes

### A.6.8.2 Slide strips

For boxes or crates of a gross weight heavier than 5 tonnes, side wall and lid edges must have suitable metal covers to protect against sling damage and prevent the lid boards from being torn off.

Dept.	Document No.	Type	Rev. Released	Lang.	Status
1350	HDST601100	DC	MK 2021-12-07	EN	Approved



## B Appendix B - Corrosion Protection

Provisions must be taken to protect all products for a minimum duration of 12 months.

Any extension of this protection period would be specified in the Purchase Order or the Shipping, Packing and Marking Instruction.

Depending on the nature and sensitivity of the products, the following methods or a combination thereof may be applied to protect the materials against corrosion and negative effects of climatic and environmental conditions. These methods are

- Protective coating method,
- Desiccant method,
- Volatile Corrosion Inhibitors (VCI's) and
- Nitrogen filling.

In case of various corrosion protection specifications for one product, the following order of precedence (Table 9) shall be applied.

Precedence	Who	Defines what	In document
1	GE product engineering department	Protective coatings	Product specification
2	GE transport engineering department	Additional corrosion protection measures	Product specific packing instruction
3	Supplier	Comprehensive corrosion protection	Supplier specific packing instruction

Table 9: Order of precedence in case of various specifications

### B.1 Protective Coating-Method

All blank, smooth and machined surfaces must be protected by a protective coating.

All paint-protected surfaces must be pre-treated to avoid corrosion.

It must be ensured that the protective coating is correct for the product and that it has no undesired side effects like contamination, which may harm other equipment or components either by direct contact or through cross-contamination. Removal coatings or cleaning of coated surfaces for proper installation and use of the product must be clearly marked and instructed.

GE's product engineering department is responsible for recommendation and authorisation of any coating.

### B.2 Desiccant Method

Using desiccants inside hermetically sealed foil packaging reduces humidity and protects the packaged products against corrosion and moisture-related damage. Desiccants need to be used in some sort of sealed wrapping to separate the air inside the packaging from the ambient air. The air enclosed in said wrapping is dehumidified by the desiccant until the humidity is so low that no corrosion can occur.

#### B.2.1 Mode of Operation

The curve of the relative humidity against time inside the foil packaging is shown in Diagram 1.

The desiccant dries the internal air of the hermetically sealed packaging within 24 hours below 20% relative humidity. Due to water vapour diffusion through the foil, the humidity rises gradually to a value, which should not exceed 40%rH at the end of the preservation period (e.g. 12 months) if the desiccant quantity is properly calculated and applied.

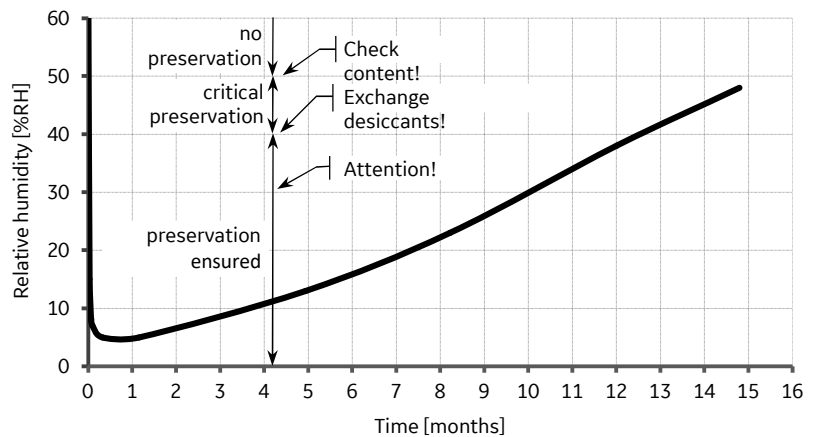

Diagram 1: Relative humidity over time within the foil packaging

Humidity indicators enable the control of the atmosphere inside the foil packaging. The long-term trend can be observed through periodic readings of the humidity indicators and data logging.

The foil packaging must not be opened prior to immediate use of the content. The corrosion protection would cease otherwise.

### B.2.2 Desiccation Material (Adsorption Material)

Desiccants or adsorbents are usually water-insoluble porous materials that, due to their large surface area, cause water molecules to adhere to them (physical adsorption). Adsorbents are bentonite, alumina, silica gel and activated carbon. The adsorbent commonly used for packaging purposes is bentonite (dry clay).

The water adsorption capacity of desiccants used in packaging is indicated in desiccant units (DU, FR: unité dessiccateur UD, DE: Trockenmitteleinheiten TME). DIN 55473, NF H 00 - 321 and military standard MIL - D - 3464 E establish a minimum adsorption capacity for desiccants. Sizes for DIN and MIL desiccants are always given in desiccant units rather than being measured in by weight. Irrespective of type, the same number of desiccant units equates to the same adsorbent capacity.

### B.2.3 Establishing the Desiccant Quantity

The following calculation formula is based on DIN 55474. Transport and storage times and the water vapour transmission rate of the foil and any hygroscopic packaging material used are all considered.

$$n = \frac{1}{a} \cdot (V \cdot b + m \cdot c + A \cdot e \cdot D \cdot t)$$

Dept.	Document No.	Type	Rev. Released	Lang.	Status
1350	HDST601100	DC	MK 2021-12-07	EN	Approved

Symbol	Unit	Description/Remark
n	DU	Number of desiccant units
a	g/DU	Adsorption capacity of one unit based on permissible final humidity level. a = 3.0 g/DU    20%rH a = 4.5 g/DU    30%rH a = 6.0 g/DU    40%rH
V	m <sup>3</sup>	Internal volume of package
b	g/m <sup>3</sup>	Absolute humidity of enclosed air. Values from Diagram 2
m	kg	Weight of hygroscopic packaging aids Moisture content of hygroscopic packaging aids c = 220 g/kg    Moist wood c = 180 g/kg    Air-dry wood c = 170 g/kg    Cardboard, paper, felt c = 130 g/kg    Rubberised hair or similar c = 100 g/kg    Dried wood c = 10 g/kg    Synthetic materials
A	m <sup>2</sup>	Surface of barrier foil packaging Correction factor based on permissible final humidity level.
e	-	e = 0.90    20%rH e = 0.80    30%rH e = 0.70    40%rH
D	g/m <sup>2</sup> · d	WVTR of barrier material see Table 11. Minimum WVTR 0.1 g/m <sup>2</sup> · d
t	d	Total transport and storage duration. 365 days by default.

Table 10: List of symbols in desiccant calculation formula

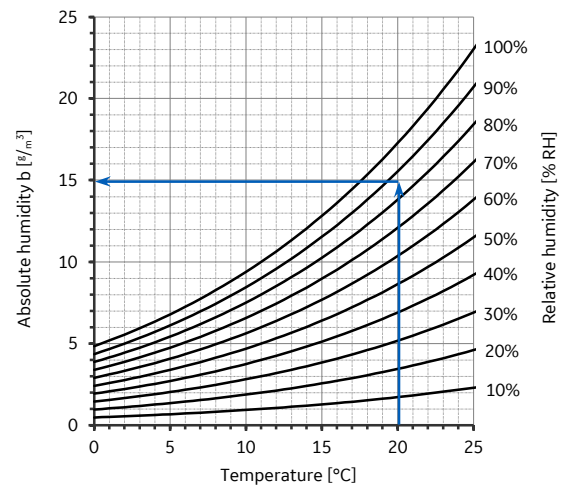

Diagram 2: Absolute humidity based on temperature and relative humidity

Material	WVTR [g/m <sup>2</sup> · d]
Polyethylene foil (PE) Transparent	< 0.3
Aluminium compound foil (polyethylene/aluminium/polyester)	< 0.1

Table 11: Water vapour transmission rate values (WVTR, coefficient D) of different barrier materials

### B.2.4 Vapour Barrier Packaging Foils

A prerequisite for the use of desiccants is hermetically sealed foil packaging. Ideally, this should be an aluminium compound foil. These compound foils have the lowest water vapour transmission rate (WVTR) and therefore offer the best protection for long-life packaging. Foil packaging is always subject to a certain level of water vapour diffusion; this value is specified by manufacturers in  $g/m^2 \cdot d$  (see exemplary values in Table 11 as per DIN 53122). This is how the amount of water vapour per  $m^2$  that diffuses through the film/foil in 24 hours is defined.

- TL - 8135 - 0003
- DIN 55532
- MIL - PRF 131
- DEF - STAN 81 - 75/1
- NF H 00 - 310

Table 12: Packaging foil standards

As some values in individual standards may vary marginally, no foil can satisfy the requirements of all standards. Foils must therefore meet the requirements of at least two of the standards listed in Table 12.

### B.2.5 Application

The package content must be clean, dry and free of fabrication residue, hand perspiration or already started corrosion.

In case of large packages, large air volumes or air freight, several small bags should be distributed within the packaging to improve the effect of the desiccant. If there is a significant temperature drop, several smaller bags can adsorb the increase in relative humidity inside packages more effectively than a large amount of centrally positioned desiccant. 8, 16 or 32 DU should be used in these packages. It is best to distribute the desiccant bags at the top of the packaging, because warmer air can hold more moisture, is lighter and therefore rises.

Sharp corners and edges of the package content must be padded well so that the foil is not torn or damaged. It should be considered that the extraction of air (see below) slightly increases the foil tension so that the foil can also be damaged by obtuse edges. The materials used to protect the foil - bubble wrap, cardboard or plastic - must be fixed at the edges, so it cannot move during transport resulting in a damaged foil.

Before the film/foil is completely sealed, some of the air must be removed from the packaging (no vacuum). This can be done using an ordinary household vacuum cleaner. This reduces the level of moisture inside the packaging.

Whenever possible the foil should have a distance to corrosive metals. The air must freely circulate to ensure the corrosion protection measures within the barrier foil to be effective.

The foil shape must not change once the air volume inside the foil has been reduced. A re-inflation of the foil shape indicates leakage, which must be corrected.

### B.2.6 Humidity Indicators

#### B.2.6.1 Application

Humidity indicators are to be applied for all packages of desiccant irrespective of their intended period of preservation.

The use of 3 step humidity indicators covering the range between 30%rH to 50%rH with instructions in English language is preferred (Table 13).



Figure 30: Inspection glass with humidity indicator



Figure 31: Plug indicator



Figure 32: Humidity indicator card

Relative humidity [%rH]	Interpretation/ Instruction if pink
30	Warning
40	Change desiccant
50	Examine item and change desiccant

Table 13: Interpretation of humidity indications



The choice of the appropriate indicator design is determined by the type of package and the choice of the barrier foil. With aluminium compound foil or other opaque foils an indicator glass (Figure 30) must be incorporated into the film, whereas plug indicators (Figure 31) are typically applied in conjunction with solid sealing covers such as blind flanges. Indicator cards (Figure 32) can be used with transparent foils provided it is ensured that the cards cannot move and thus make it impossible to read the card.

### B.2.6.2 Environmental and Health-Related Requirements

Conventional moisture indicators may contain cobalt chloride or cobalt dichloride (CoCl<sub>2</sub>), considered to be carcinogenic, teratogenic and potentially mutagenic. Their use is prohibited.

Only humidity indicators free of cobalt chloride and other contact allergens such as chromium (Cr), cadmium (Cd) and nickel (Ni) are to be used. Ideally, they are also free of heavy metals and thus produced without environmental and hazardous substances. It is essential to pay attention to the labels cobalt dichloride free and heavy metal free.

### B.2.6.3 Inspection Opening

For all contents being sealed in a barrier foil, an inspection hole of at least 90 mm in diameter must be drilled into the outer packaging, usually the wooden box, at the position of the humidity indicator. The inspection opening is to be equipped with a swivel cover (Figure 33) to prevent the ingress of small animals.



Figure 33: Swivel cover

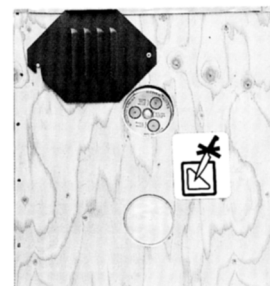

Figure 34: Open inspection opening with indicator

Wherever possible, the inspection opening (Figure 34) is to be incorporated in an easily accessible location, preferably near the marking, and at eye level or lower.

Inspection openings must never be made in the lids of transport boxes.

### B.2.7 Marking of desiccant preservation

The word „DESICCANT“ along with the roof symbol (Figure 35) must be marked in black ink above inspection openings. This graphic symbol is not in accordance with DIN standards. It has however gained general acceptance as indicator of packages containing drying agents and is sometimes requested by Client packing specifications.

The “Do not destroy barrier” label as per Figure 36 is widely used although it is not specified by ISO.

A label as per Figure 37 must be affixed to temporary covers of products, whose interiors are preserved by desiccant bags, which need to be removed during erection.



Figure 35: Desiccant symbol



Figure 36: Do not destroy barrier

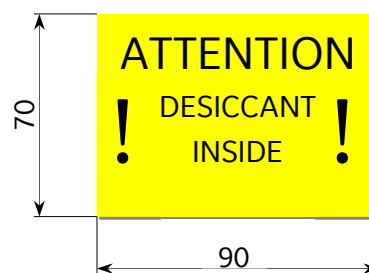

Figure 37: Desiccant label

Dept.	Document No.	Type	Rev. Released	Lang.	Status
1350	HDST601100	DC	MK 2021-12-07	EN	Approved



### B.3 VCI Method

The use of VCI agents (Volatile Corrosion Inhibitor) serve the purpose of corrosion protection within foil packaging. The VCI inhibitors sublime from the carrier material in the closed package and form a protective coating on the metal part. Thus, moisture can make no direct contact to the metal surface, which greatly slows or even stops the corrosion process.

#### B.3.1 Mode of Operation

VCIs are polar organic and inorganic compounds with a cathodic and anodic protective effect that can be applied to virtually any carrier material. The VCI carrier materials gradually emits the VCI inhibitors, which adsorb on the surfaces to form a molecular protective layer. VCI molecules are deposited as an invisible, mono-molecular protective layer on the bare metal surface. Depending on the polarity of the material to be protected, the reverse-polarised molecules are deposited on it (Figure 38). The VCIs neutralise the corrosion-triggering electrochemical processes. The permanently released substances protect against the effects of corrosion caused by atmospheric oxygen, industrial pollutants, water vapour, seawater, wood acid and sweat. Two types of VCI protection methods are generally distinguished.

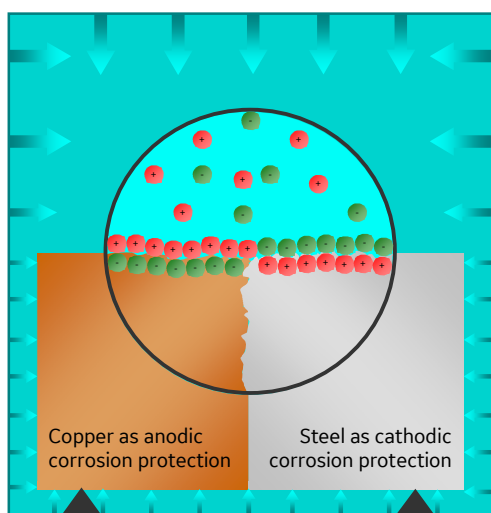

Figure 38: Functional principle

The first is the contact phase inhibitor. It unfolds its effect via direct contact with the product.

The other is the vapour phase inhibitor evaporating from its carrier material and saturate the enclosed air space completely with VCI molecules. Hence, irregularly shaped products with inaccessible areas, as well as hollow bodies, threads, bearings and pipes can also be protected. No direct contact between the carrier material and the product is required here. Distance between emitting foil and surface to be preserved typically vary between 30 and 50 cm. The vapour phase of the VCI inhibitors on package foils increasingly loses its effect with growing space. The vapour phase of the package foil must then be supported with suitable emitters or VCI foam depots.

Today, commonly available VCI agents usually have a combined effect for several product types. The recommendations of the VCI supplier must be observed.

VCI wrappings can be opened briefly and for a limited number of times for checking, however must be closed again immediately. After reclosing, the protective atmosphere is automatically regenerated inside the wrapping.

#### B.3.2 Physiological properties

During processing n-nitrosamines and n-dicyclohexyl nitrosamines may occur when using nitrite containing foils. These substances are highly carcinogenic, and in some cases, also mutagenic, and are therefore strictly prohibited. Thus, only nitrite-free VCI materials must be used for packaging.

The VCI chemicals used for the nitrite-free VCI materials are toxicologically harmless. It is nevertheless advisable to provide good ventilation at the workplace. No food or beverages should be stored or consumed at the workplace. Hands and face should be washed thoroughly before eating and drinking or contacting mucous membranes. VCI materials may only be used when the corresponding safety data sheets are available for them.

Dept.	Document No.	Type	Rev. Released	Lang.	Status
1350	HDST601100	DC	MK 2021-12-07	EN	Approved

### B.3.3 Types of delivery

Various suppliers offer a comprehensive line of system-compatible materials:

- LDPE, LLDPE and HDPE foils (low and high-pressure polyethylene foils) impregnated or coated with VCI in every imaginable version (mono, coex and stretch foils).
- Open-cell PU foam impregnated with VCI; as rolls, blanks and strips, including as self-adhesive materials.
- VCI paper and cartons
- VCI dispensers for fleece bags, plastic shells and foam cylinders filled with VCI powder
- VCI oils, high-performance foil formers with various consistencies and viscosities (oily, greasy, firm) with actively effective contact and vapour-phase inhibitors.
- VCI powder and tablets

### B.3.4 Special forms of VCI

#### B.3.4.1 VCI silver protection paper

Silver protection paper is a bleached kraft paper, provided with an abrasive free coating. This adsorbs and bonds the sulphur compounds of the air (H<sub>2</sub>S) and prevents their reaction with the metal. The quality reliably protects silver parts. Silver protection paper maintains the function of silver parts, e.g. contacts which must remain bare due to further processing or the maintenance of the function and must not be brought into contact with other protective agents. It is neutral relative to other materials. The material quantity and the duration of protection must be obtained from the VCI supplier.

#### B.3.4.2 VCI oil

VCI corrosion protection oil is a mineral oil charged with highly-active organic corrosion inhibitors. VCI corrosion protection oils must be free of solvent, nitrite, phosphate and chromate and must not contain any polychlorinated biphenyls (PCB) and polychlorinated terphenyls (PCT).

The drip-proof, oily film protects metal surfaces twice as effectively:

- Due to its oil-soluble inhibitors
- Due to the protective effect of the inhibitors evaporating from the VCI protective film, which condense on the metal surfaces, including where the liquid agent cannot form a layer.

This dual effect offers reliable protection for parts in closed systems.

VCI corrosion protection oil protects both ferrous and non-ferrous metals against corrosive effects, even under difficult conditions. The VCI corrosion protection oil must have a multi-metal protection and must not cause any negative reactions to paints and plastic surfaces.

The material quantity and the duration of protection must be obtained from the VCI supplier.

When using oils, the compatibility with the power plant chemistry must be clarified to exclude contaminants during later operation of the products (refer to B.1).

### B.3.5 Applications

Small parts or products can be packaged in VCI bags. Smaller individual parts can be preserved in foils or closed transport boxes with blanks made of VCI foam. Larger products can be packaged with foil and the protective effect inside can be supplemented with VCI foam or powder.

VCI can basically be used for all product groups. Depending on the complexity of the products, the use of additional VCI foams, powders or emitters may be necessary.

- Foil package outside: always with box hoods and bottom covers made of VCI or by wrapping the product in VCI flat foils.
- Inner packaging: VCI foam and as a supplement for highly corrosion-sensitive surfaces, VCI oils and VCI dispensers for switchgear and control cabinets.

The following can be used:

- |   |                         |
|---|-------------------------|
| • Bare surfaces                           | VCI oils                |
| • Electrical/electronic equipment         | VCI emitters, VCI foams |
| • Accessories, small parts and components | VCI foil                |

Dept.	Document No.	Type	Rev. Released	Lang.	Status
1350	HDST601100	DC	MK 2021-12-07	EN	Approved



**B.3.6 Wooden parts and hygroscopic materials**

Wooden parts and other hygroscopic materials, e.g. packaging aids or padding materials should always be packed in PE or other vapour-tight foils or separated from the metal by the foil as an intermediate layer. Wood impregnating agents can impair or even abrogate the VCI protective effect.

**B.3.7 Removing residues**

Residues, fingerprints, dirt, dust or corrosion already present is to be removed before packing with the VCI carrier material to ensure optimum corrosion protection.

The objects shall be packed immediately after cleaning and drying.

**B.3.8 Duration of protection**

The duration of protection is up to 3 years. It depends on the selection and combination of the various VCI materials, the tightness of the outer packaging, the climatic conditions and proper use (dosing, maximum distances of the vapour phase). The manufacturer's specifications must be observed.

**B.3.9 Marking**

VCI warning labels (Figure 39) must be applied to all sides and ends of the packaging unit. The labels must be at least in English language, for all shipments.

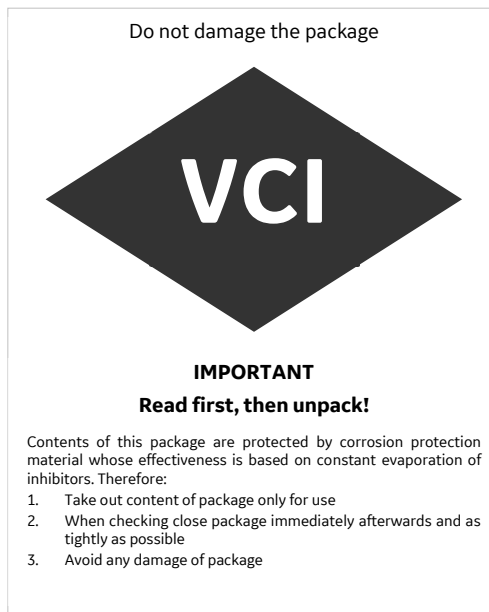

Figure 39: VCI-warning label

Dept.	Document No.	Type	Rev. Released	Lang.	Status
1350	HDST601100	DC	MK 2021-12-07	EN	Approved



### B.4 Nitrogen Filling

Nitrogen is a non-flammable, colourless, odourless and tasteless gas, and the main component of our ambient air (approximately 78 % volumetric content). Nitrogen is chemically inert and therefore does not or only insignificantly react with potential reaction partners.

The charging of closed spaces with inert gases is called inerting, where the air and the oxygen it contains is displaced by an inert gas. In this case, the nitrogen content is over 99%. The corrosion protection is established by the absence of oxygen required for oxidation.

Basically, inerting would also be possible with any other inert gas (e.g. carbon dioxide or all noble gases). Nitrogen however can easily be "disposed of" in the ambient air as it is the major component of our atmosphere

This preservation method is only effective if there is no air exchange between the inner and the outer atmosphere. Thus, gas-tight systems or products in a gas-tight packaging can be protected.

#### B.4.1 Prerequisites

To use nitrogen for corrosion protection, several conditions must be met:

- The system or container must be designed gas-tight.
- There must be openings for introducing nitrogen.
- If a permanent gauge pressure shall be applied, it must be proven that the system is designed to bear such pressure. Certification may be required depending on the pressure level and applicable regulation. Moreover, a manometer for reading the internal pressure, a safety valve as well as a fitting for refills or a gas cylinder must be mounted.
- The nitrogen content must be measurable during filling without nitrogen escaping in large quantities.

#### B.4.2 Purge and Filling Pressure

The purge pressure is dependent on the design and the maximum design pressure of the system or container. Not all systems can be purged with the same pressure. Pressure-change flushing may be carried out with both gauge pressure and vacuum. This must be observed for the purge pressure, as a design for e.g. 2 bar gauge pressure does not necessarily mean that the system is also designed for vacuum. The permissible purge pressure must be clarified with the responsible product development department in advance and whether flushing shall be carried out with gauge pressure or vacuum.

The filling pressure, like the purge pressure, is dependent on the design and the maximum design pressure of the system or container. The corrosion protection can be maintained with either gauge pressure or unpressurised.

Dept.	Document No.	Type	Rev. Released	Lang.	Status
1350	HDST601100	DC	MK 2021-12-07	EN	Approved



Figure 40: Nitrogen purged transformer furnished with gas cylinder



Figure 41: Nitrogen container for long term storage



#### B.4.2.1 Gauge Pressure (Overpressure)

An application using gauge pressure prevents the intrusion of oxygen due to leakage. A manometer must be mounted on the system or container for checking the interior pressure at any time. The long-term trend can be observed through periodic readings of the gauges and data logging. It is important to note, however, that no statement about the quality of corrosion protection can be made with a pressure gauge. It is not possible to detect how the gauge pressure is generated. All openings should be sealed after purging should tampering be eliminated.

Depending on the tightness of the pressurised system, a refill will eventually be necessary. Very tight systems are preferably equipped with a refill fitting. Alternatively, a compressed gas cylinder can be attached directly to the container (Figure 40, Figure 41), which however triggers the package to be treated as dangerous goods. Depending on the amount of the gauge pressure containers must comply with the local legal and normative requirements of pressure vessel construction. Pressurization due to the corrosion protection only is usually not effective.

All fittings (manometer, safety valve, refill fitting, etc.) and gas cylinders must be located at an accessible yet non-exposed and protected position to prevent damage during transport and storage.

#### B.4.2.2 Unpressurised (at Ambient Pressure)

The nitrogen remains under atmospheric pressure, when applying the unpressurised method. The risk of leakage is usually smaller, since there is a smaller pressure gradient between the outer and inner atmosphere, which is usually caused by meteorological differences.

The application of manometer or refill fitting can be omitted making it the more cost effective alternative.

#### B.4.3 Relevance to Dangerous Goods

Nitrogen as a gas is classified under UN number UN1066 (Nitrogen, compressed) and is categorised to non-flammable gases under class 2.2. It should be noted that the pressure is considered hazardous. In the dangerous goods regulation for air cargo<sup>1</sup>, an exception is formulated as follows:

“Gases of Division 2.2 [class 2.2], are not subject to these Regulations if they are transported at pressure less than 200 kPa at 20°C are not liquefied or refrigerated liquefied gases.”

Regulation of rail and road transportation as well as maritime cargo include corresponding exception rules. Considering that the temperature and thus the pressure may vary considerably during transportation and storage (refer to section 2), containers, systems or parts thereof (gas cylinders), which are pressurised with 200 kPa or more during transport, shall be packaged, labelled marked and declared in accordance with the relevant Dangerous Goods Regulations (refer to section 3).

Dept.	Document No.	Type	Rev. Released	Lang.	Status
1350	HDST601100	DC	MK	EN	Approved

<sup>1</sup> Section 3.2.2.4.1, p.143, Dangerous Goods Regulations, International Air Transport Association Montreal, 57<sup>th</sup> Edition, 1. January 2016, ISBN 978-92-9252-534-7