



SAFETY RECALL BULLETIN

SUBJECT: 2008–2013 LANCER EVOLUTION CLUTCH MASTER CYLINDER – SAFETY RECALL CAMPAIGN – REVISED			No: SR-13-009REV
			DATE: December, 2013
			MODEL: 2008 – 2013 Lancer Evolution
CIRCULATE TO:	<input checked="" type="checkbox"/> GENERAL MANAGER	<input checked="" type="checkbox"/> PARTS MANAGER	<input checked="" type="checkbox"/> TECHNICIAN
<input checked="" type="checkbox"/> SERVICE ADVISOR	<input checked="" type="checkbox"/> SERVICE MANAGER	<input checked="" type="checkbox"/> WARRANTY PROCESSOR	<input checked="" type="checkbox"/> SALES MANAGER

This bulletin supercedes SR-13-009, issued November, 2013 to remove the requirement that pre-repair photos be taken of each Brembo brake caliper, but it is still recommended. See Page 23 for additional details. Changes are italicized and indicated by ◀.

PURPOSE

Due to the insufficient bonding strength of clutch master cylinder components on certain 2008 – 2013 Lancer Evolution vehicles, separation may occur, resulting in fluid leakage. This condition results in the inability to engage or disengage the clutch, limits the ability to shift the transmission into or out of a gear, and can create a no start condition once the vehicle comes to a stop.

This campaign bulletin instructs dealers to replace the clutch master cylinder with a counter measure unit, and if necessary, modify the existing clutch pedal with an interference protection plate.

AFFECTED VEHICLES

Certain 2008 – 2013 Lancer Evolution vehicles with Manual Transmission built from December 12, 2007 to March 5, 2013

IMPORTANT

Affected new or used inventory vehicles must be repaired before the vehicle is delivered. Dealers must check their inventory vehicles' VINs on the Warranty Super Screen to verify whether the vehicle is involved in this recall campaign. It is a violation of Federal law for a dealer to deliver a new motor vehicle or any new or used item of motor vehicle equipment (including a tire) covered by the notification under a sale or lease until the defect or non-compliance is remedied.

CUSTOMER NOTIFICATION

A letter will be sent to all owners of affected vehicles telling them to visit their local Authorized Mitsubishi Motors dealer to have their clutch master cylinder replaced and if necessary, the clutch pedal modified. A copy of the customer notification letter appears at the end of this bulletin.

REQUIRED OPERATIONS

Before starting this campaign procedure, **CHECK THE WARRANTY SUPERSCREEN** to verify if the vehicle is an affected VIN for this campaign and this campaign procedure has not already been completed.

⚠ CAUTION	The Clutch Master Cylinder Replacement Kit Part Number 2345A059 must be handled with care. If the piston rod becomes disconnected from the clutch master cylinder, <u>DO NOT USE IT.</u>
------------------	---

⚠ CAUTION	Genuine Mitsubishi DOT 3 Brake Fluid Part Number MZ311987 must be used to bleed the clutch and brake systems. Use 1.5 L of new fluid to completely purge the old fluid.
------------------	--

⚠ CAUTION	To prevent damage to the vehicle's finish, do not spill brake fluid or touch any painted surfaces with gloves, shop rags, or tools covered in brake fluid.
------------------	---

Continued
Copyright 2013, Mitsubishi Motors North America, Inc.

(4104)

The information contained in this bulletin is subject to change. For the latest version of this document, go to the Mitsubishi Dealer Link, MEDIC, or the Mitsubishi Service Information website (www.mitsubishitechinfo.com).

REQUIRED EQUIPMENT

The following equipment is needed to bleed the clutch and brake systems:

- Venturi Vacuum Brake Bleeder
- Oil Syringe with Extension Hose
- Hose Pincher

REMOVAL PROCEDURE

1. Place the vehicle on a lift. With the vehicle parked, engage the parking brake and set the transmission to neutral. Open the trunk and remove the trunk room mat, trunk room floorboard and battery access cover. Disconnect the negative (-) terminal of the battery and insulate the disconnected negative (-) cable with electrical tape.

REMINDER: If the vehicle is not equipped with the optional OEM navigation unit, please record all radio station presets and reprogram when repair is completed.

NOTE: During connection, use hand tools only. Torque specification is 44 ± 9 in-lb (5 ± 1 N-m).

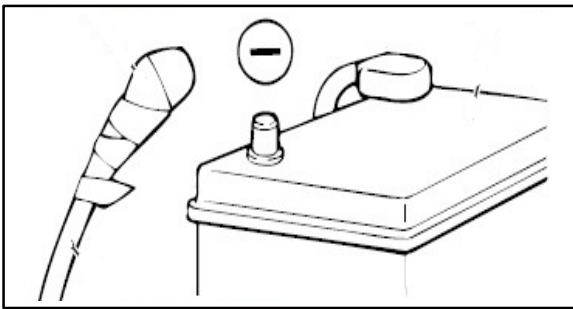

2. Remove the air intake assembly. Cover the air cleaner intake hose with duct tape to prevent intrusion of foreign material.

NOTE: During reinstallation, use hand tools only. Torque specification for the air intake assembly bolts is 62 ± 27 in-lb (7 ± 3 N-m).

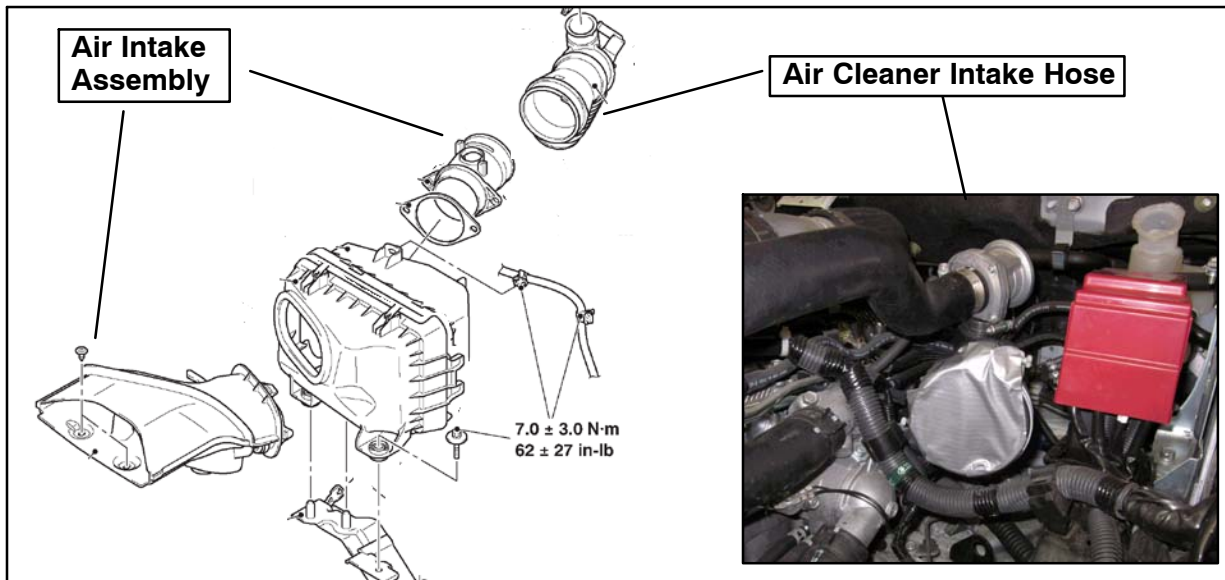

3. Remove the strut tower bar. Once removed, reinstall the six strut mounting nuts and torque to specification to maintain suspension structure.

NOTE: During reinstallation, use hand tools only. Torque specification for the two center nuts is 19 ± 3 ft-lb (26 ± 5 N-m) and the six strut mounting nuts is 35 ± 5 ft-lb (45 ± 7 N-m).



4. Remove brake fluid from the reservoir assembly using one of the following methods:

NOTE: Skip this step during vehicle reassembly.

CAUTION Cover the surrounding area of the reservoir assembly with shop rags to protect from brake fluid spillage. If spillage occurs, clean the area immediately with commercially available car wash shampoo, rinse with water, dry with shop rags and remove remaining residue with compressed air.

- a. Method #1 – Remove the filter from the reservoir assembly. Use an oil syringe with extension hose to extract as much fluid as you can from the reservoir assembly.



- b. Method #2 – Connect the brake bleeder hose to the slave cylinder bleeding nipple. Proceed to bleed as much fluid as you can from the reservoir assembly.

CAUTION Cover the surrounding area of the slave cylinder with shop rags to protect from brake fluid spillage. If spillage occurs, clean the area immediately with commercially available car wash shampoo, rinse with water, dry with shop rags and remove remaining residue with compressed air.

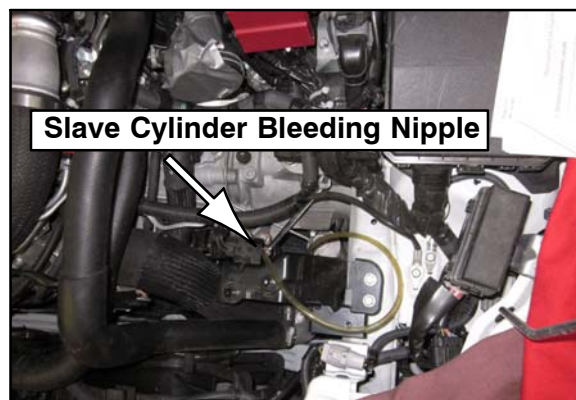

5. From the engine control harness connector bracket, remove the following components:
- a. Fusible link box cover.

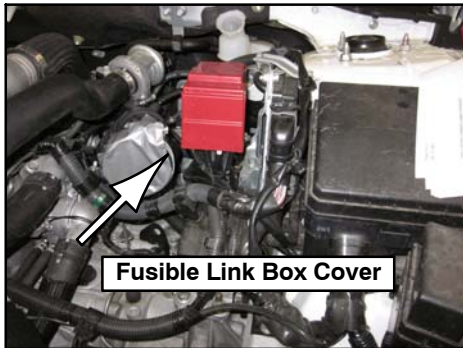

- b. Battery harness connection nut. Once the nut is removed, set the battery harness connection aside in the engine bay.

NOTE: During reinstallation, use hand tools only. Torque specification is 102 ± 22 in-lb (12 ± 2 N-m).

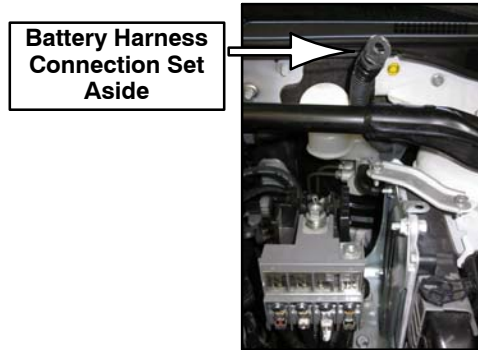

- c. Wiring joint by removing the three indicated bolts. Once the wiring joint is removed, remove the fusible link box connection off the wiring joint's mounting bolt. **Do not disconnect the fusible link box connection.**

NOTE: During reinstallation, use hand tools only. Torque specification is 35 ± 17 in-lb (4 ± 2 N-m)

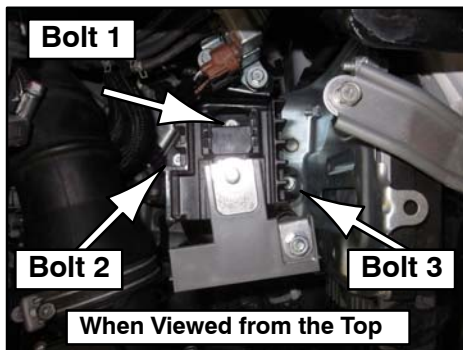

- d. Solenoid valve assembly by removing the two indicated bolts.

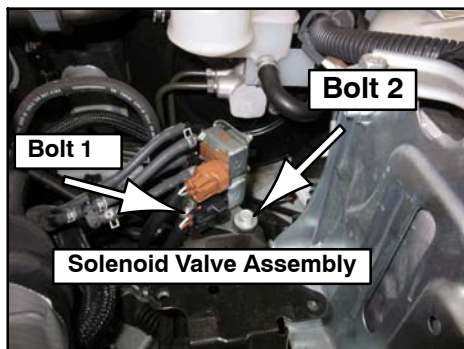

NOTE: During reinstallation, use hand tools only. Torque specification is 48 ± 12 in-lb (5.5 ± 1.5 N-m).

6. Remove the left front interior scuff plate and cowl side trim.

CAUTION During removal and installation of interior components, do not apply excessive weight to the left (exterior) side air dam. It may become disconnected.

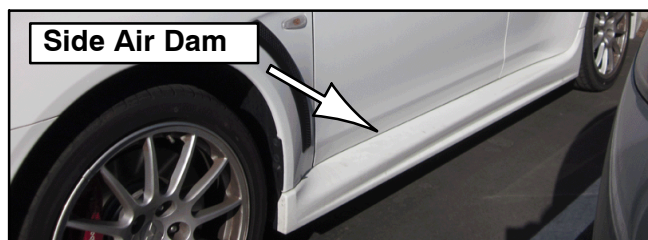

NOTE: If equipped with the accessory floor illumination package, unclip the cowl side trim and then disconnect the LED connector.

7. Remove the fuse box cover.

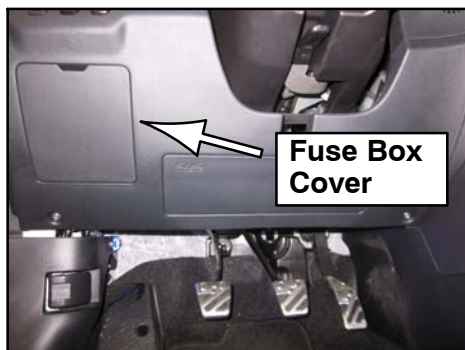

8. Remove the lower instrument panel cover by removing the four indicated tabs. Remove the two indicated screws from the instrument panel cover assembly and unclip it from the instrument panel, **but do not remove it at this time**. Disconnect the headlight leveling switch and ASC Off switch harness connection, and then remove the instrument panel cover assembly from the vehicle.

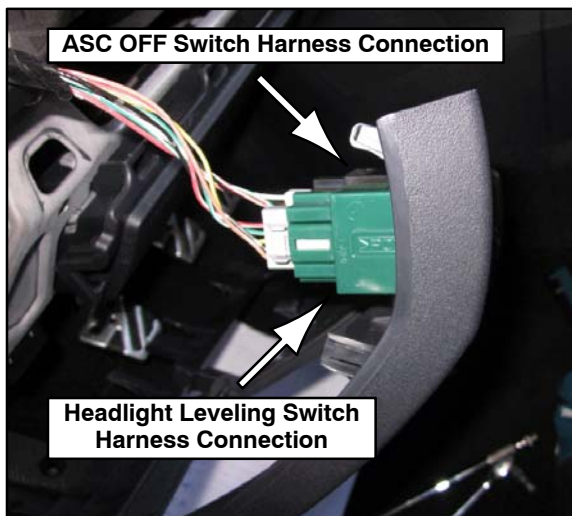
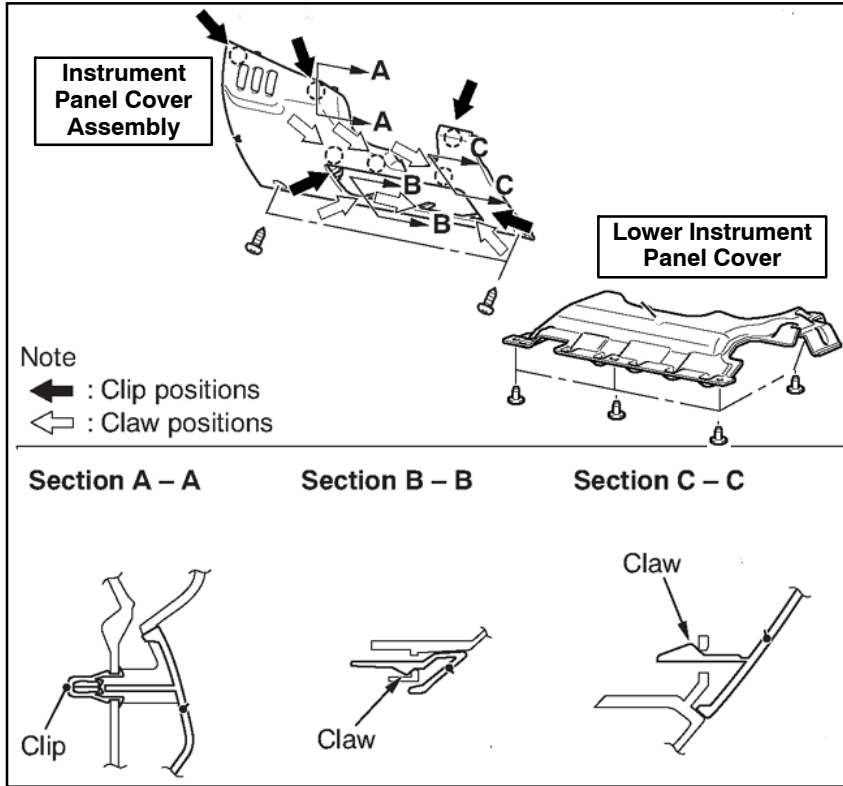

9. Disconnect the ETACS-ECU.
 - a. Remove all wire harness connectors.

NOTE: Illustration shown below is for information purposes only.

NOTE: All connectors are white unless otherwise indicated.

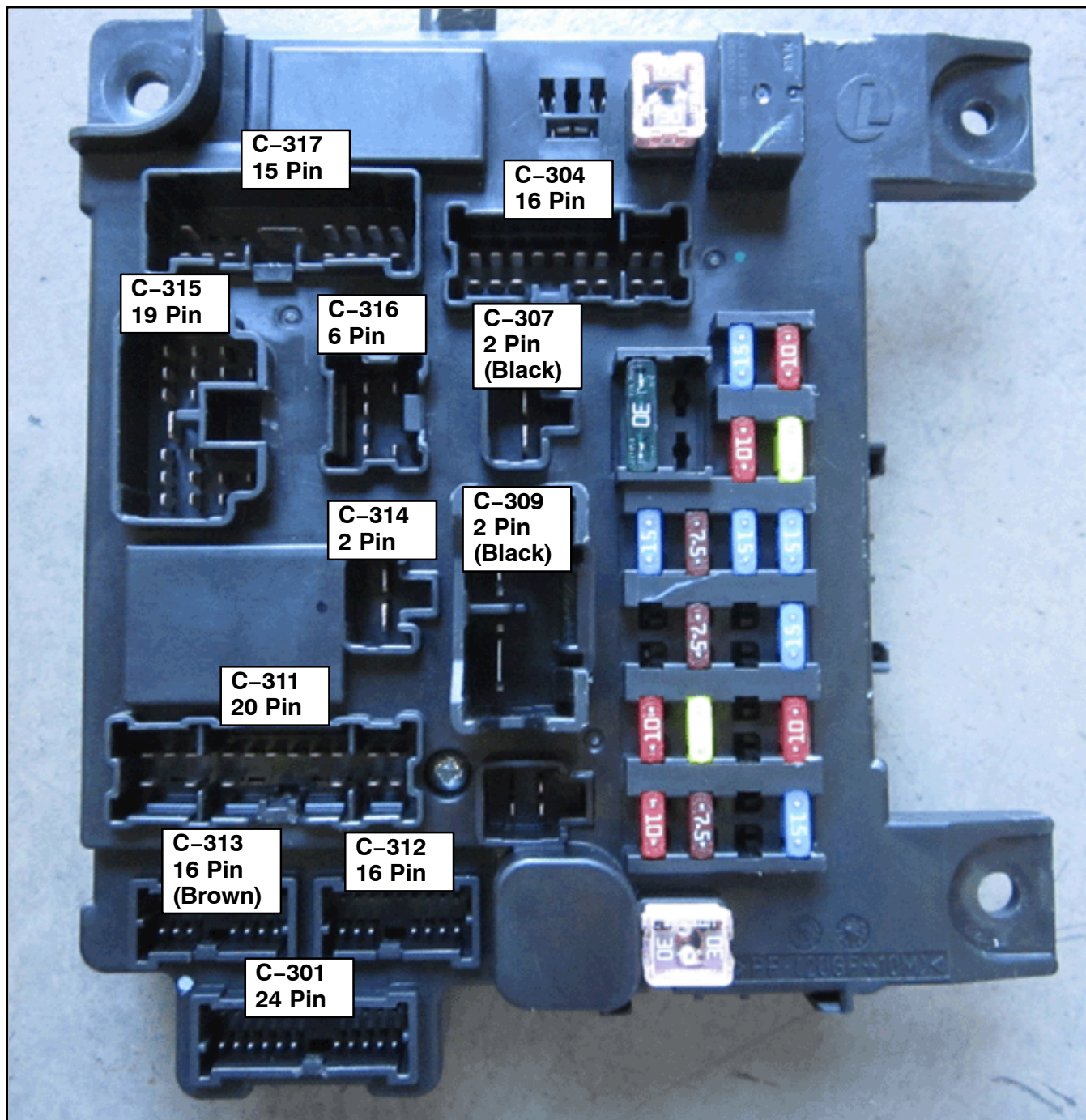

- b. Remove the three indicated bolts, **but do not remove the ETACS-ECU from the vehicle at this time.**

NOTE: During reinstallation, use hand tools only. Torque specification is 36 ± 17 in-lb (4 ± 2 N-m).

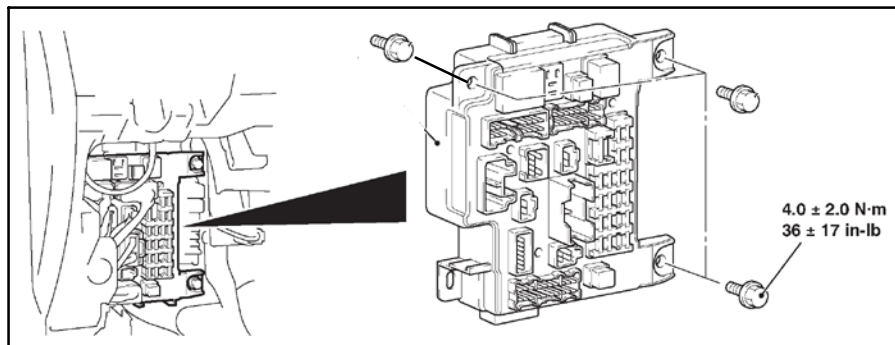

- c. Disconnect the Relay/Fuse box from the ETACS-ECU by depressing the locking tab and sliding it towards you.

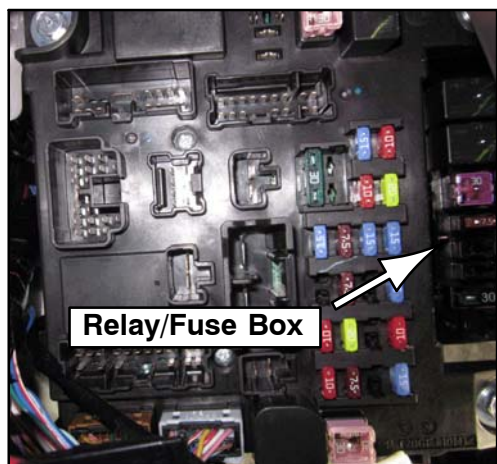

- d. Remove ETACS-ECU from the vehicle.

- 10. Disconnect the harness connector and unbolt the indicated bolt to remove the AWC-ECU.

NOTE: During reinstallation, use hand tools only. Torque specification is 76 ± 13 in-lb (8.5 ± 1.5 N-m).

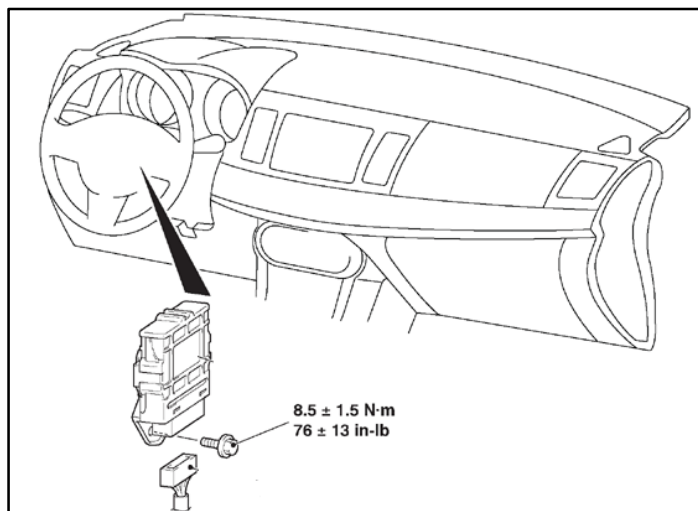

11. From the engine compartment, use a pick to unlock the clutch master cylinder clip to the maximum range allowed and disconnect clutch tube assembly A from the clutch master cylinder.

CAUTION Cover the surrounding engine compartment components with shop rags to protect from brake fluid spillage. If spillage occurs, clean the area immediately with commercially available car wash shampoo, rinse with water, dry with shop rags and remove remaining residue with compressed air.

CAUTION Do not damage the clutch tube assembly A O-ring during disconnection. If damaged, clutch tube assembly A must be replaced.

NOTE: To prevent fluid leakage, use a hose pincher on the hose between the clutch master cylinder and the reservoir assembly.

NOTE: To prevent fluid leakage, use the yellow caps from the (new) replacement clutch master cylinder unit and install them to the (old) current clutch master cylinder.

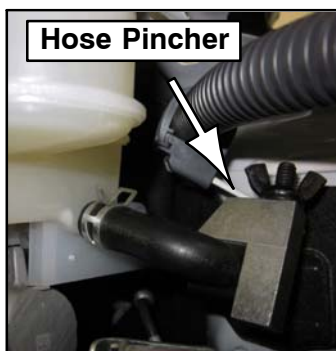
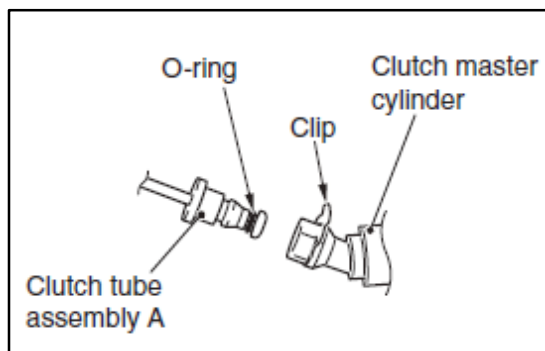

12. Unclip the clutch switch harness connector and clutch interlock switch harness connector. Unbolt the clutch pedal assembly, **but do not remove the clutch pedal assembly at this time.**

NOTE: During reinstallation, use hand tools only. Torque specification for the clutch pedal assembly is 11 ± 2 ft-lb (15 ± 3 N-m).

CAUTION To prevent damage to the switches, do not apply any grease to them, or handle with gloves covered in grease.

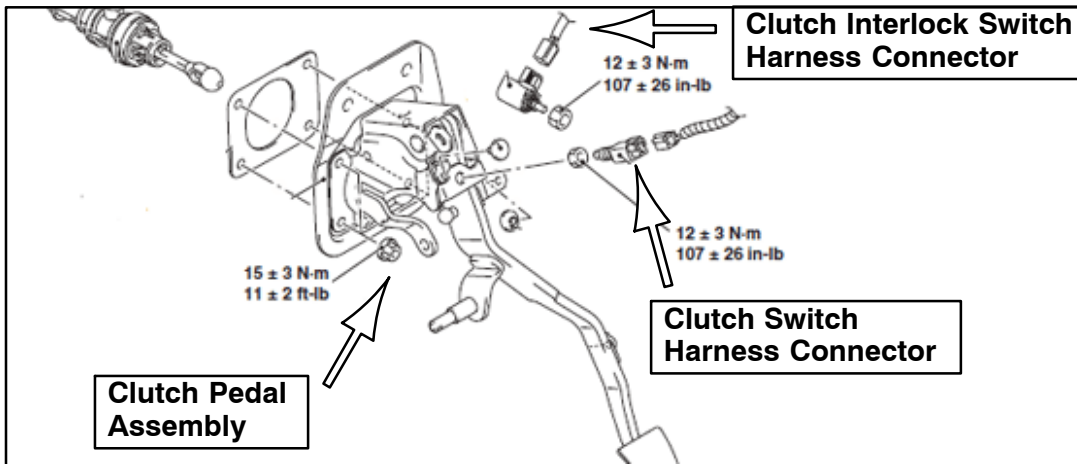

13. The front wiring harness and the instrument panel wiring harness are attached to the top of the clutch pedal assembly. To prevent damage to the wire harnesses, they must be disconnected prior to clutch pedal assembly removal.

NOTE: During vehicle reassembly, ensure the two wire harness clips are reattached prior to proceeding to the next step.

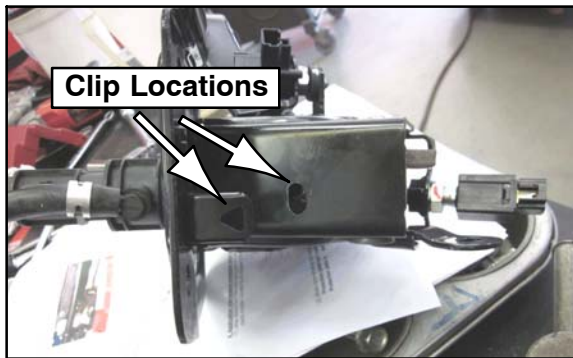

14. Remove the clutch pedal assembly and clutch master cylinder from inside the vehicle.

WARNING THE CLUTCH PEDAL IS SPRING LOADED. SERIOUS INJURY MAY OCCUR IF HANDS OR FINGERS ARE CAUGHT IN THE PEDAL WHEN DEPRESSING OR RAISING IT.

CLUTCH PEDAL MODIFICATION PROCEDURE

1. With the clutch pedal assembly and clutch master cylinder removed from the vehicle, separate the clutch master cylinder piston rod from the clutch pedal spherical pin. Then rotate the clutch master cylinder 45 degrees clockwise (when viewed from the angle shown below) and remove it from the clutch pedal assembly.

⚠ WARNING THE CLUTCH PEDAL IS SPRING LOADED. SERIOUS INJURY MAY OCCUR IF HANDS OR FINGERS ARE CAUGHT IN THE PEDAL WHEN DEPRESSING OR RAISING IT.

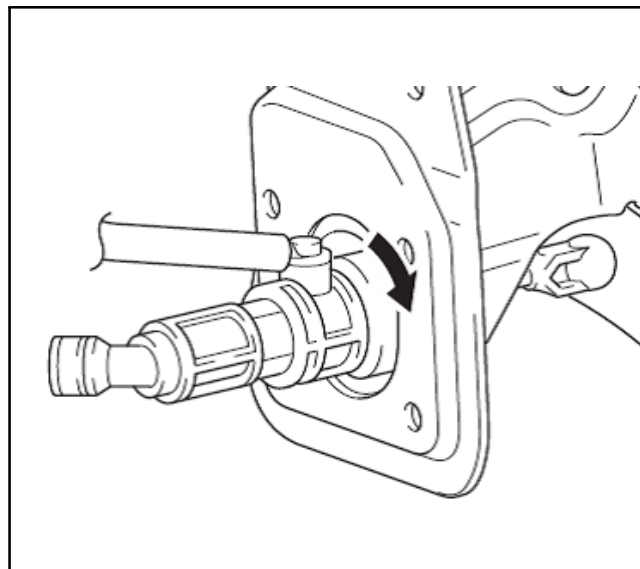

2. Inspect the clutch pedal to determine if an interference protection plate has already been attached to it.

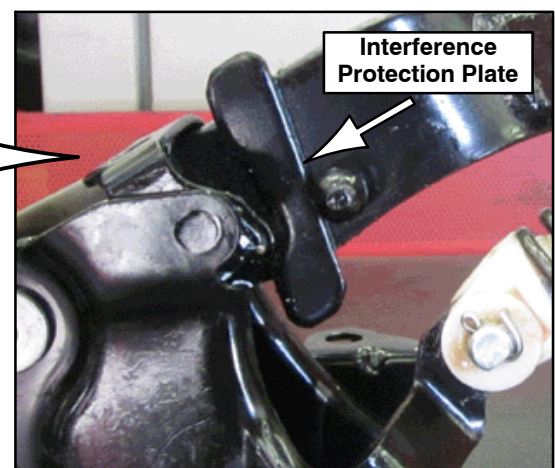
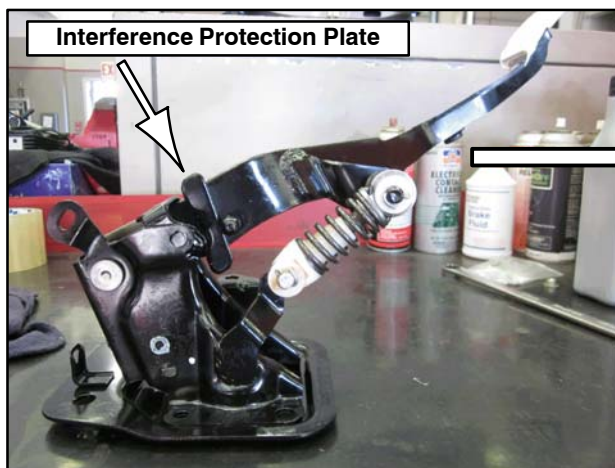

- a. If the interference protection plate is attached to it, proceed directly to the **INSTALLATION PROCEDURE** in the following section.
- b. If the interference protection plate is absent, proceed directly to Step 3 below.

3. Place the clutch pedal flat on a level surface. Visually inspect and touch the area near the spherical pin for welding spatter. If present, remove the welding spatter with a slotted screwdriver or similar tool.

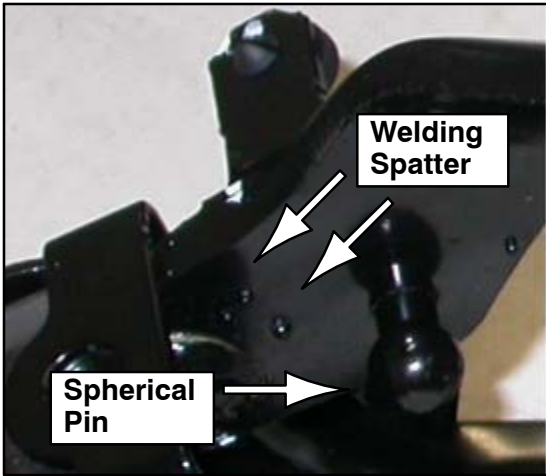

4. Once the welding spatter is removed, clean the area with a degreasing agent. Ensure the area is flat, clean, and dry before proceeding.
5. Peel the release paper from the interference protection plate (located in the Clutch Master Cylinder Replacement Kit Part Number 2345A059) and apply the plate to the clutch pedal, aligning it with the arm's edge and adjacent to the spherical pin as shown below. Use pliers or similar tool to press bond the plate to the clutch pedal.



Interference Protection Plate

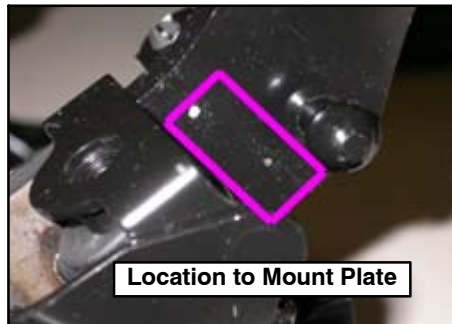

Location to Mount Plate

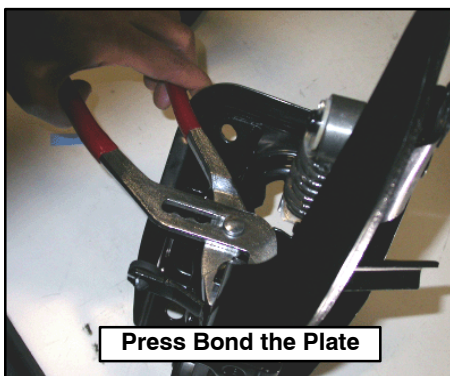

Press Bond the Plate

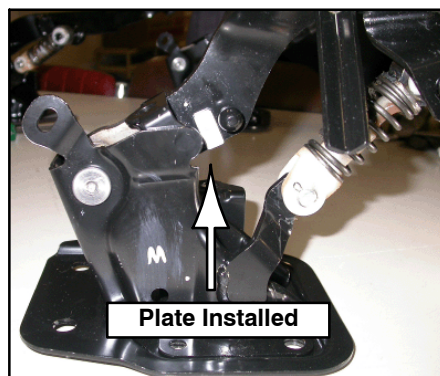
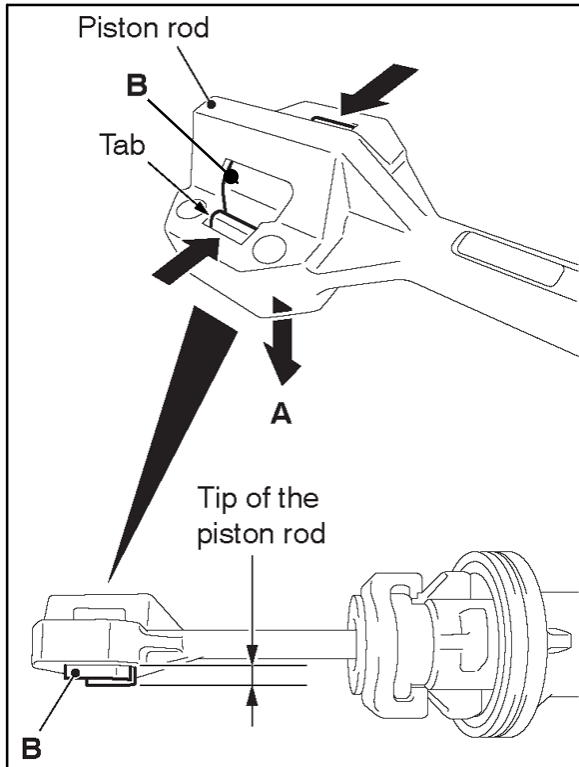

Plate Installed

INSTALLATION PROCEDURE

1. Ensure the replacement clutch master cylinder piston rod is prepared for installation.
 - a. Push out the “B” portion in the “A” direction while pressing the two tabs on the tip of the piston rod.
 - b. Check that the “B” portion protrudes from the tip of the piston rod.

NOTE: If the “B” portion does not protrude, it cannot be engaged into the clutch pedal spherical pin.



2. Ensure the white markings on the piston rod and housing are aligned with one another. If not aligned, gently rotate the rod so the white markings are in alignment.

CAUTION The clutch master cylinder must be handled with care. If the piston rod becomes disconnected from the clutch master cylinder, do not use it.

CAUTION Ensure the white markings are always aligned. If not aligned, the piston rod may become disconnected from the clutch master cylinder.



- When inserting the clutch master cylinder piston rod into the clutch pedal assembly, ensure the piston rod opening is facing between the 9 o'clock and 12 o'clock position as shown below. If the piston rod opening is facing in any other position and installed, it may become misaligned and disconnect from the clutch master cylinder.

CAUTION Do not move the piston rod during insertion. If it moves, it may become misaligned and disconnect from the clutch master cylinder.

CAUTION Ensure the piston rod is inserted into the clutch pedal as shown below the "OK" caption box. If the piston rod is inserted in any other way, it may become misaligned and disconnect from the clutch master cylinder.

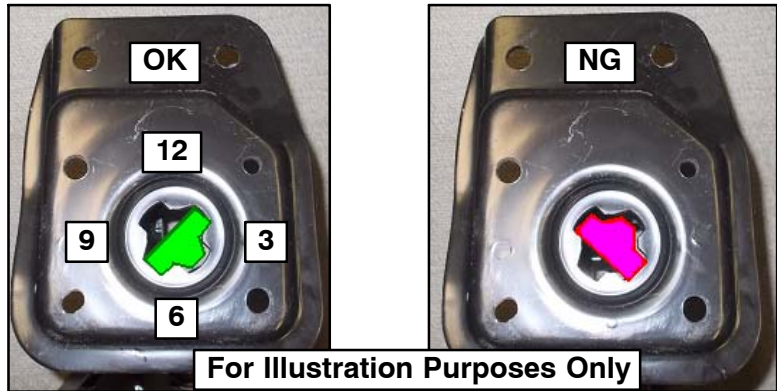

- Insert the clutch master cylinder completely into the clutch pedal assembly. Secure the clutch master cylinder to the clutch pedal assembly by rotating it counter clockwise (when viewed from the angle shown below).



5. Hold the clutch pedal plate with a vise. Depress the clutch pedal arm and connect the spherical pin to the clutch master cylinder piston rod. Ensure the spherical pin is completely inserted into the piston rod and the piston rod's interior housing clip is engaged to secure the piston rod to the spherical pin.

⚠ WARNING THE CLUTCH PEDAL IS SPRING LOADED. SERIOUS INJURY MAY OCCUR IF HANDS OR FINGERS ARE CAUGHT IN THE PEDAL WHEN DEPRESSING OR RAISING IT.

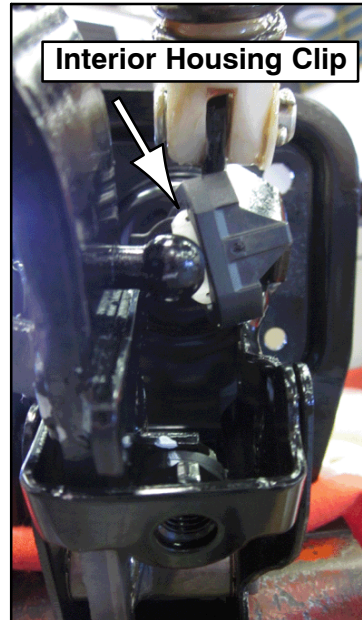

6. Ensure the white markings on the clutch master cylinder are still in alignment after installation to the clutch pedal assembly.
7. Beginning with Step 14 of the **Removal Procedure**, follow the steps in reverse order until you complete Step 11 to reinstall the clutch pedal assembly.

⚠ CAUTION When connecting clutch tube assembly A with the clutch master cylinder, ensure the O-ring and clip are not broken. If broken, the component(s) must be replaced. Prior to installation, use brake fluid and a shop rag to remove any dirt from these components.

8. Once reinstalled, measure the clutch pedal free play and clutch pedal height when the clutch is disengaged.
 - a. Clutch pedal free play, measurement "B", should be between 0.16 – 0.35 in (4 – 9 mm). If measurement "B" is not within the provided range, ensure the clutch pedal spherical pin is properly connected to the clutch master cylinder piston rod and measure again.

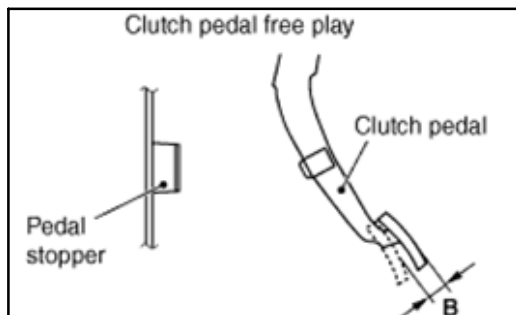

- b. Clutch pedal height, measurement “C”, should be between 4.33 – 4.56 in (110 – 116 mm). If measurement “C” is not within the provided range, you may rotate the pedal stopper adjustment screw to adjust the clutch pedal height.

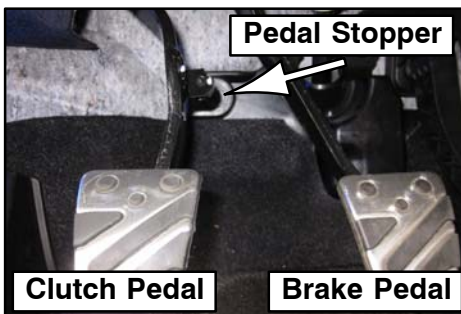
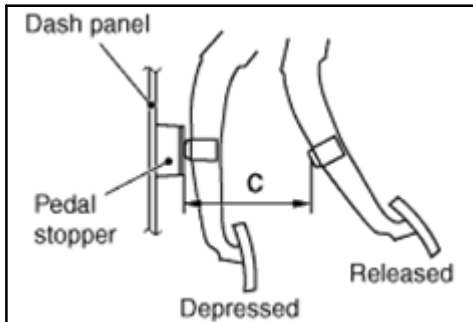

9. Check the switch components and ensure they are set to the following factory specifications:
- a. Clutch interlock switch, measured while the pedal is completely depressed. You may rotate the pedal stopper adjustment screw (as shown in Step 8b) to adjust the height of the clutch interlock switch when the pedal is completely depressed.

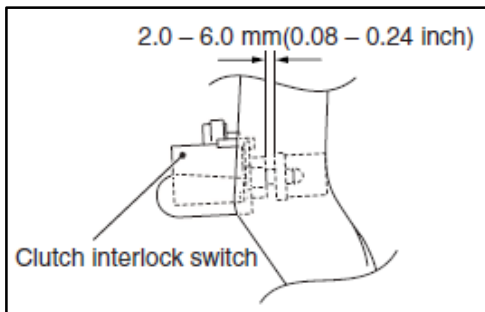

- b. Clutch switch, measured while the pedal is completely released. You may adjust the clutch switch by loosening the lock nut and rotating the body of the clutch switch.

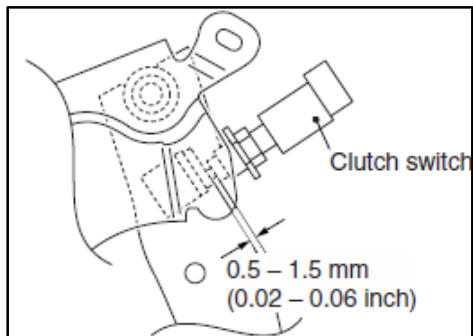

CLUTCH AND BRAKE BLEEDING PROCEDURE

CAUTION Genuine Mitsubishi DOT 3 Brake Fluid Part Number MZ311987 must be used to bleed the clutch and brake systems. Use 1.5 L of new fluid to completely purge the old fluid.

CAUTION During the clutch and brake bleeding procedure, ensure the reservoir assembly has sufficient brake fluid. Maintain the fluid level at all times to prevent air from entering the system.

1. Lift the vehicle off the ground. Remove all four wheels.



2. ***If appropriate, photograph and note the condition of each brake caliper. See Page 23 to determine photos are required.***

3. All clutch and brake fluid must be purged from the system and be exchanged with new fluid. Pour Genuine Mitsubishi DOT 3 Brake Fluid Part Number MZ311987 into the reservoir assembly until it reaches the indicated MAX. If the reservoir assembly filter was removed in Step 4a of the **Removal Procedure**, reinstall it.

CAUTION Cover the surrounding area of the reservoir assembly with shop rags to protect from brake fluid spillage. If spillage occurs, clean the area immediately with commercially available car wash shampoo, rinse with water, dry with shop rags and remove remaining residue with compressed air.

4. Attach the brake bleeder hose to the slave cylinder bleeding nipple. Loosen the nipple and start the brake bleeder. When air is completely removed from the slave cylinder, stop the brake bleeder, torque nipple to 8 ± 1 ft-lb (11 ± 1 N-m), and disconnect the brake bleeder hose.

CAUTION Cover the surrounding area of the slave cylinder with shop rags to protect from brake fluid spillage. If spillage occurs, clean the area immediately with commercially available car wash shampoo, rinse with water, dry with shop rags and remove remaining residue with compressed air.

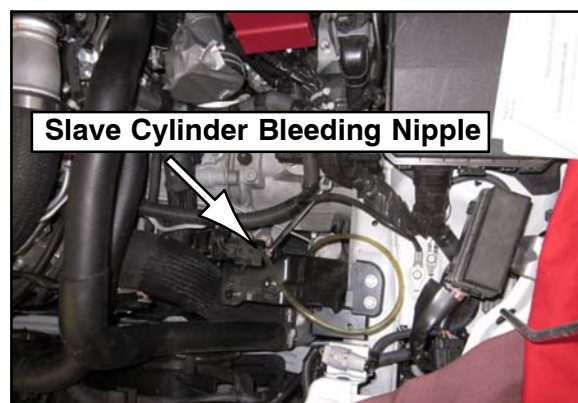

5. Use the remaining brake fluid to bleed the brakes and completely purge the old fluid. Starting with the right rear caliper, connect the brake bleeder hose to the outside-facing bleeder screw. Loosen the screw and start the brake bleeder. When air is completely removed from that brake line and caliper, stop the brake bleeder and remove the hose.

CAUTION Take care to avoid damaging the brake calipers with tools or brake fluid. Brake fluid can cause peeling of the special brake caliper coating.

CAUTION When bleeding, always use a hose connected to the bleeder screw to direct brake fluid into a proper container.

CAUTION Cover the surrounding area of the bleeder screw with shop rags to protect from brake fluid spillage. If spillage occurs, clean the area immediately with commercially available car wash shampoo, rinse with water, dry with shop rags and remove remaining residue with compressed air.

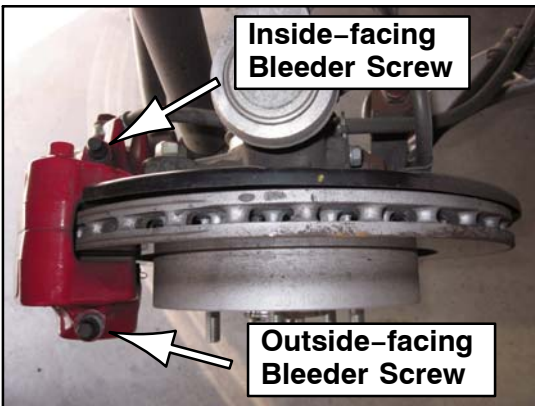

6. Blow air into the top of the bleeder screw to remove any remaining brake fluid from the bleeder screw hole. Air pressure should be regulated to a low setting to minimize splatter. Securely tighten the brake bleeder screw.

CAUTION Wear safety glasses and protective gloves when using air pressure to remove brake fluid from the bleeder valve.

CAUTION Cover the surrounding area of the bleeder screw with shop rags to protect from brake fluid splatter. If splatter occurs, clean the area immediately with commercially available car wash shampoo, rinse with water, dry with shop rags and remove remaining residue with compressed air.

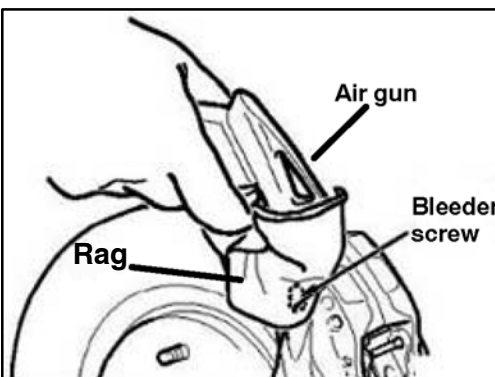

7. Repeat Steps 5 – 6 for the inside-facing bleeder screw.
8. Perform Steps 5 – 7 on the remaining calipers in the order shown below.

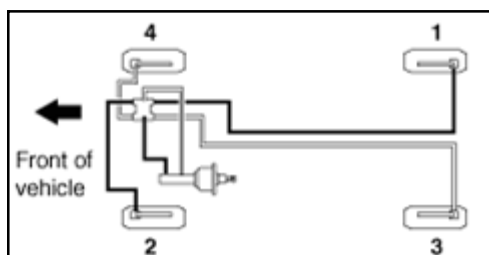

9. **If brake fluid spillage or splatter occurred on any caliper, completely clean the area with commercially available car wash shampoo, rinse with water, dry with shop rags and remove remaining residue with compressed air again.**
10. Depress the clutch pedal and brake pedal a few times. Ensure there are no fluids leaking in the clutch and brake system, including all hose and pipe connections.
11. Ensure the fluid level in the reservoir assembly is adequate. Secure the cap on the reservoir assembly.
12. Reinstall all four wheels and lower the vehicle. Torque specification for the wheel nuts is 73 ± 7 ft-lb (98 ± 10 N-m).
13. Beginning with Step 10 of the **Removal Procedure**, follow the steps in reverse order (skip Step 4) to reassemble the vehicle.
14. Turn the ignition switch to the ON position. Ensure no warning indicators illuminate in the multi-information display. If any warning indicators illuminate, check for DTCs and troubleshoot per the service manual.
15. Complete one final check to the clutch pedal. Ensure the gap between the clutch pedal and pedal stopper at the point of clutch disengagement, measurement "D", is greater than 0.53 in. (13.5mm). If not within specification, diagnose per the applicable model year Lancer Evolution Service Manual – Group 21: Clutch > On-Vehicle Service > Clutch Pedal Check.

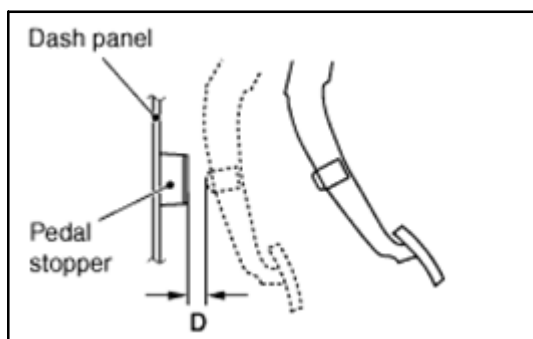

16. Test drive the vehicle and ensure there is no abnormality in clutch and brake function. If the vehicle is not equipped with the optional OEM navigation unit, please reprogram the clock and radio station presets before returning the vehicle to the customer.
17. *If appropriate, upload brake caliper photos to the PRC.*



PARTS INFORMATION

Use the genuine Mitsubishi Parts listed below:

Description	Part Number	Quantity
Kit, Clutch Master Cylinder Replacement	2345A059	1
Brake Fluid (1 Bottle = 12 oz.)	MZ311987	1.5 L (5 Bottles)

A supply of the above parts will be automatically shipped to dealers to allow for rework of **all in-stock / new unsold vehicle(s)**. Some dealers may also be **force allocated stock** using a formula based on the proximity and percentage of applicable registered VINs by ZIP code.

Parts shipment will be processed via the 'R' order type and will be shipped along with your scheduled stock order beginning Tuesday, November 5, 2013. Dealers may place additional orders via the MDL.

Please refer to Parts Bulletin 21-LE-01-13 for additional information.

WARRANTY INFORMATION

There is only one repair scenario

#	Repair Procedures	Campaign Operation	Labor Time Allowance
1	Replace Clutch Master Cylinder <i>Replace clutch master cylinder, take photos for all 4 calipers if appropriate, bleed and refill system with new MMNA brake fluid.</i>	C1309W01	3.5 hours



WARRANTY / SERVICE CAMPAIGN CLAIM INFORMATION

Enter all claims as claim type 'C' – Recall/Campaign Claims

There is only one applicable operation code that matches up with the work performed. A claim example to follow is provided below.

Certain 2008 – 2013 MY Lancer Evolution models:

Required Operation to be performed	Labor Operation	Labor Time
------------------------------------	-----------------	------------

1. Replace Clutch Master Cylinder, Take Photos if Applicable, Bleed System, & Replace Fluid	C1309W01	3.5 hrs. ◀
---	----------	------------

Claim Header Section: 2008 – 2013 MY Lancer Evolution Clutch Master Cylinder

MITSUBISHI DEALER LINK Service Warranty Warranty Claim Help

Claim Entry Vehicle Information PQR/VQR

Campaign Information

Campaign Operation No	C1309W__	Enter As	
Miles/Km	64500		
VIN	JA.....	Repair Date	
Service Technician	Emp No	Service Advisor	
Spec Value *		Duplicate Recall *	<input type="checkbox"/>
Dealer: 99320	Ref No:	VIN:	
Claim No:	Adj:	Claim Status: Incomplete	Model and Year:

Save & Continue Main Menu

Enter in the first 6 characters of this campaign labor operation: C1309W.

This campaign is for the replacement of the clutch master cylinder on certain 2008-2013MY Lancer Evolution models only. Check the Open Recall area of the MDL Superscreen each time to be certain of a vehicle's eligibility and to insure the repair has not already been performed.

After entering the required customer data, vehicle information and selecting the one campaign operation number from the menu, hitting the “Save and Continue” button will automatically fill-in several fields.

CAMPAIGN INFORMATION				C1309W01 Replace Clutch Master Cylinder	
Campaign Operation No	C1309W	2008-2013 Lancer Evolution Only	Repair Performed	Repair Order No	EX12345
Miles / KM	64,500		Repair Date In	Repair Date Out	11 / 10 / 2013
VIN	JASAW68VX8U043186				

Campaign Claim Example:

Follow these instructions for claiming for performing the required 2008 – 2013 MY Lancer Evolution Clutch Master Cylinder replacement.

PARTS:

A replacement clutch master cylinder (2345A059) and new MMNA sourced brake fluid (MZ311987) are required to be entered on the claim in the parts section.

current part prices will be entered for you							
	Delete	Part No	Part Description	Qty	Unit Price	Part Amount	Primary
1	<input type="checkbox"/>	2345A059	CYLINDER ASSY,CLUTCH MASTER	1	\$ xx.xx	\$ xx.xx	<input checked="" type="radio"/>
2	<input type="checkbox"/>	MZ311987	BRAKE FLUID,DOT-3	5	\$ xx.xx	\$ xx.xx	<input type="radio"/>

LABOR:

The full campaign labor operation number of C1309W01 and the allowed labor time of 3.5 hours will be automatically entered as a result of your 'Repair Performed' selection from the “Vehicle” page.

MITSUBISHI DEALER LINK							
Claim Entry		Vehicle Information		Corporate		e-Reports	
Vehicle		Parts		Step 3: Labor		Review	
Add Page - Labor Information							
Delete	Sublet	Labor Op	Labor Operation Description	Qty	Hours / Sublet Amt	Total Labor Hrs	Labor Amt
		C1309W01	Replace clutch master cylinder, take photos if applicable, then bleed and refill system with new MMNA brake fluid.	1	3.5	3.5	XX.XX

Photos: To protect dealers from possible future contentions from a vehicle owner that the caliper finish damage was caused by the dealer's prior recall repair procedure, it is highly recommended to document any existing brake caliper conditions prior to repair by taking photos and entering a damage description in the Photo Required Condition System (PRC) on an exception-basis only.

Pre-repair photo documentation is required whenever a dealer encounters any type of existing brake caliper finish issue, such as chipping, fading, peeling, overheating, fluid leakage from a prior brake system repair or ANY other pre-existing condition.

If, in the future there is contention that a customer's damaged calipers may have been due to a dealer's recall claim repair process, PRC archived photos showing the caliper's pre-repair condition will be a major piece of evidence to exonerate the dealer and aid in avoiding a very costly comeback.

- Customer Relations
- Photos Required Condition Center
 - Photos Required Condition Entry System

MITSUBISHI DEALER LINK
Photo Required Condition & Pre Approval Center

Add New Photos Required Condition

Enter a 9 Digit or a Full VIN to add a new Photo Submission.

Enter Dealer Code

VIN
Model
In Serv

MITSUBISHI DEALER LINK
Photo Required Condition & Pre Approval Center

Add New Photos Required Condition

Repair Type ALL

Country ALL

Directions from MMNA. P

VIN	Model	Description
U018520	2011 OUT	PAINT DELAM INSPECT
U036228	2011 LAN	RECALL PHOTO SUPPORT
U043408	2012 LAN	SPECIAL REQUESTS BY PROD SUPP

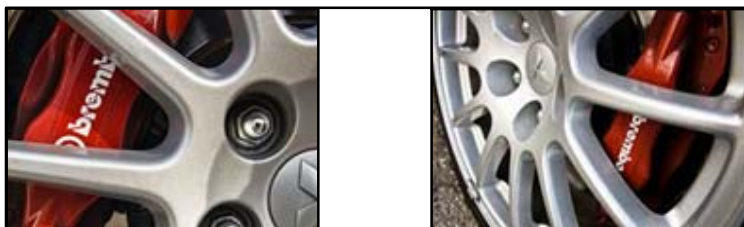



IMPORTANT SAFETY RECALL

Mitsubishi Motors North America, Inc.
6400 Katella Avenue
Cypress, CA 90630
Telephone: 714-372-6000
www.mitsubishicars.com

This notice applies to your vehicle, _____.

This notice has been sent to you in accordance with the requirements of the National Traffic and Motor Vehicle Safety Act.

Date: November, 2013

Dear Mitsubishi Owner,

Reason for notice: Mitsubishi Motors North America, Inc. (MMNA) has decided that a defect which relates to motor vehicle safety exists in certain 2008 - 2013 Lancer Evolution vehicles. Due to the insufficient bonding strength of clutch master cylinder components, separation may occur, resulting in fluid leakage.

This condition results in the inability to engage or disengage the clutch, limits the ability to shift the transmission into or out of a gear, and can create a no start condition once the vehicle comes to a stop, which could lead to a greater risk of crash.

What you should do: Please contact your local Authorized Mitsubishi Motors dealer and schedule an appointment to have the clutch master cylinder replaced. When you bring your vehicle in, please show the dealer this letter. (If you misplace this letter, the dealer will still make this inspection/repair to your vehicle, free of charge.)

What your dealer will do: The dealership will replace the clutch master cylinder, change the clutch fluid, the brake fluid, and if necessary, modify the existing clutch pedal with an interference protection plate.

How long will it take? The time needed for this repair is approximately 4 hours. The dealer may need your vehicle for a longer period of time due to service scheduling issues, but every effort will be made to minimize your inconvenience.

If you experience any problem having your vehicle repaired promptly and/or at no charge, please inform us by calling the Mitsubishi Customer Relations Department at 888-648-7820. Hours: Monday through Friday 7 a.m. to 4 p.m. (Pacific Time)

If, after contacting Mitsubishi Customer Relations, you still have a problem getting this repair made promptly and/or without charge, write to the Administrator, National Highway Traffic Safety Administration, 1200 New Jersey Avenue SE, Washington, D.C. 20590, or call the toll-free Vehicle Safety Hotline at 1-888-327-4236 (TTY: 1-800-424-9153), or go to <http://www.safercar.gov>.

If you have already encountered a problem with the clutch master cylinder and had it replaced as a result of this specific condition and have paid for the repair, you may send your original receipts and/or other adequate proof of payment to the following address for reimbursement consideration:

Mitsubishi Customer Relations Department, P.O. Box 6400, Cypress, CA 90630-0064

Notice to Lessors: If you are a lessor of five or more leased vehicles as of the date of this letter, you have an obligation under federal law, (49 CFR Part 577), to provide each lessee of the above referenced vehicle with a copy of this letter by first class mail within ten days of receipt. Further, you must maintain a record which identifies each lessee to whom you sent a copy of this letter, the date you sent it, and the vehicle identification number (VIN) of the subject vehicle.

We appreciate your prompt attention to this matter.

Sincerely,

Mitsubishi Motors North America, Inc.

C1309W