

PanelView 300 Keypad Terminals

Catalog Number 2711-K3xxxxx

Topic	Page
Important User Information	2
Hazardous Location Considerations	3
European Union Directive Compliance	3
Wiring and Safety Guidelines	4
Enclosures	5
Required Tools	5
Clearances	6
Installing Terminal in Panel	7
Installing the Memory Card Retainer	9
Connecting DC Power	10
Battery Removal and Disposal	11

For more information on the PanelView 300 Operator Terminals, refer to Publication [2711-UM014](#).

Important User Information

Solid state equipment has operational characteristics differing from those of electromechanical equipment. Safety Guidelines for the Application, Installation and Maintenance of Solid State Controls (Publication SGI-1.1 available from your local Rockwell Automation sales office or online at <http://literature.rockwellautomation.com>) describes some important differences between solid state equipment and hard-wired electromechanical devices. Because of this difference, and also because of the wide variety of uses for solid state equipment, all persons responsible for applying this equipment must satisfy themselves that each intended application of this equipment is acceptable.





In no event will Rockwell Automation, Inc. be responsible or liable for indirect or consequential damages resulting from the use or application of this equipment.

The examples and diagrams in this manual are included solely for illustrative purposes. Because of the many variables and requirements associated with any particular installation, Rockwell Automation, Inc. cannot assume responsibility or liability for actual use based on the examples and diagrams.

No patent liability is assumed by Rockwell Automation, Inc. with respect to use of information, circuits, equipment, or software described in this manual.

Reproduction of the contents of this manual, in whole or in part, without written permission of Rockwell Automation, Inc., is prohibited.

Throughout this manual, when necessary, we use notes to make you aware of safety considerations.

<p>WARNING</p> 	<p>Identifies information about practices or circumstances that can cause an explosion in a hazardous environment, which may lead to personal injury or death, property damage, or economic loss.</p>
<p>IMPORTANT</p>	<p>Identifies information that is critical for successful application and understanding of the product.</p>
<p>ATTENTION</p> 	<p>Identifies information about practices or circumstances that can lead to personal injury or death, property damage, or economic loss. Attentions help you identify a hazard, avoid a hazard and recognize the consequences.</p>
<p>SHOCK HAZARD</p> 	<p>Labels may be on or inside the equipment, for example, a drive or motor, to alert people that dangerous voltage may be present.</p>
<p>BURN HAZARD</p> 	<p>Labels may be on or inside the equipment, for example, a drive or motor, to alert people that surfaces may reach dangerous temperatures.</p>

Hazardous Location Considerations

This equipment is suitable for use in Class I, Division 2, Groups A, B, C, D; Class II, Division 2, Groups F and G; Class III Division 2; or non-hazardous locations only. The following **WARNING** statement applies to use in hazardous locations.

WARNING



EXPLOSION HAZARD

- Substitution of components may impair suitability for Class I, Class II, Class III Division 2.
- Do not replace components or disconnect equipment unless power has been switched off or the area is known to be non-hazardous.
- Do not connect or disconnect components unless power has been switched off or the area is known to be non-hazardous.
- This product must be installed in an enclosure. All cables connected to the product must remain in the enclosure or be protected by conduit or other means.
- All wiring must comply with N.E.C. article 501-4(b), 502-4(b), 503-3(b) as appropriate.

See the nameplate on terminal for hazardous locations certifications.

ATTENTION



In Class I, Class II, Class III Division 2 Hazardous locations, the PanelView 300 terminal must be wired per the National Electric Code as it applies to hazardous locations. Peripheral equipment must also be suitable for the location in which it is installed.

The PanelView 300 terminals have an operating temperature code of T4 (maximum operating temperature of 135 °C or 275 °F). Do not install the terminals in environments where atmospheric gases have ignition temperatures less than 135 °C (275 °F).

European Union Directive Compliance

If this product has the CE mark it is approved for installation within the European Union and EEA regions. It has been designed and tested to meet the following directives.

EMC Directive

This apparatus is tested to meet Council Directive 89/336/EEC Electromagnetic Compatibility (EMC) and amending directives 91/263/EEC, 92/31/EEC, 93/68/EEC using the following standards, in whole or in part:

- EN 50081-2 EMC - Generic Emission Standard, Part 2 -Industrial Environment
- EN 50082-2 EMC - Generic Immunity Standard, Part 2 - Industrial Environment⁽¹⁾
- EN 61000-6-2 EMC - Generic Immunity Standard, Part 2 - Industrial Environment⁽²⁾

This product is intended for use in an industrial environment.

Low Voltage Directive

This product is tested to meet Council Directive 73/23/EEC Low Voltage, by applying the safety requirements of EN 61131-2 Programmable Controllers, Part 2 - Equipment Requirements and Tests. For specific information required by EN 61131-2, see the appropriate sections in this publication, as well as the Allen-Bradley publication Industrial Automation Wiring and Grounding Guidelines For Noise Immunity, publication [1770-4.1](#).

This equipment is classified as open equipment and must be mounted in an enclosure during operation to provide safety protection.

Wiring and Safety Guidelines

Install the PanelView 300 keypad terminal using publication 70E, Electrical Safety Requirements for Employee Workplaces. In addition to the NFPA general guidelines, follow these recommendations:

- Route incoming power to the PanelView 300 terminal by a separate path from the communications cable.
- Where power and communication lines must cross, they should cross at right angles. Communications lines can be installed in the same conduit as low level DC I/O lines (less than 10 Volts).
- Grounding minimizes noise from Electromagnetic Interference (EMI) and is a safety measure in electrical installations. To avoid EMI, shield and ground cables appropriately.
- A source for grounding recommendations is the National Electrical Code published by the National Fire Protection Association of Boston.

⁽¹⁾ PV300 Series A, REV A only.

⁽²⁾ PV300 Series A, REV B; PV300 Series B and Later.

Enclosures

Mount the PanelView 300 keypad terminal in a panel or enclosure to protect the internal circuitry. The terminal meets NEMA Type 12/13 and 4X (indoor use) ratings only when properly mounted in a panel or enclosure with the equivalent rating.

Allow enough space within the enclosure for adequate ventilation. Consider heat produced by other devices in the enclosure. The ambient temperature around the PV300 terminal must be between 0...55 °C (32...131 °F).

Make provisions for accessing the back panel of the terminal for wiring, maintenance, installing a memory card, and troubleshooting.

Required Tools

Other than the tools required to make the panel cutout, the tools required for installation are:

- 7mm (M4) deep well socket wrench or nut driver.
- small slotted screwdriver.
- torque wrench (N•m, lb•in).

Mounting Dimensions

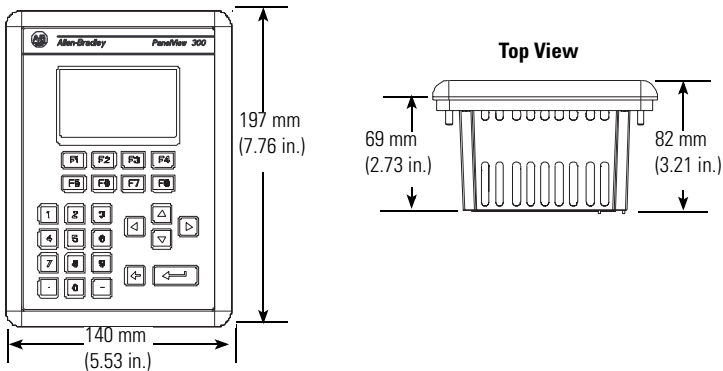

Cutout Dimensions

Use the full size template shipped with the PV300 terminal to mark the cutout dimensions. The figure below shows a reduced size cutout.

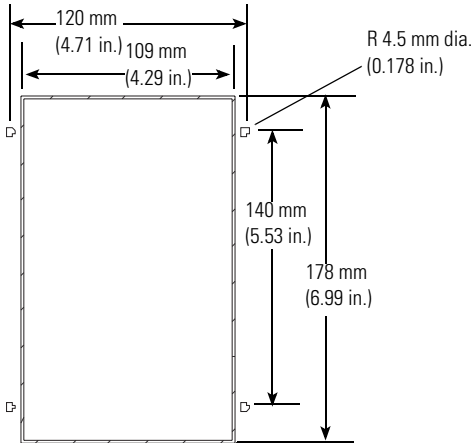

Clearances

Allow adequate clearances for mounting, air flow, maintenance, and for installing a memory card and legend insert.

Side, Top and Bottom Clearances

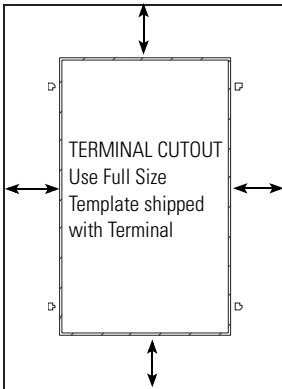

Leave 64 mm (2.5 in.)
for Mounting and Air Flow

Leave 64 mm (2.5 in.)
for Mounting and Air Flow

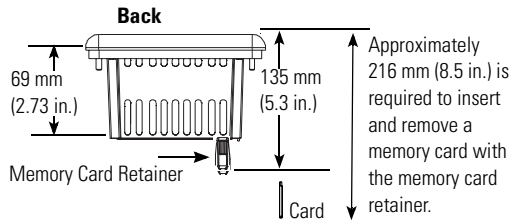

Installing Terminal in Panel

To install the PV300 keypad terminal in a panel:

ATTENTION



Disconnect all electrical power from the panel before making cutout.

Make sure the area around the panel cutout is clear.

Take precautions so that metal cuttings do not enter any components that may already be installed in panel.

Failure to follow this warning may result in personal injury or damage to the panel components.

1. Cut an opening in the panel using the panel cutout provided with the terminal. Remove sharp edges or burrs.
2. Make sure the sealing gasket is properly positioned on the terminal (as shown below). This gasket forms a compression type seal. Do not use sealing compounds.

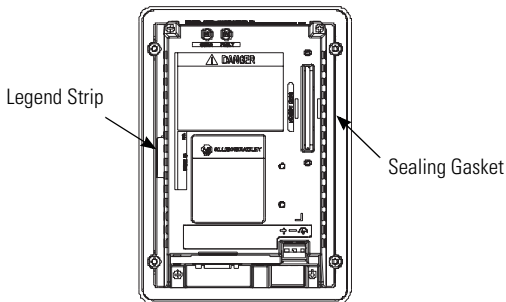

3. Verify that the end of the legend strip is fully inserted and does not interfere with the sealing gasket.
4. Place the terminal in the panel cutout.

5. Install the 4 self-locking nuts, hand tight.

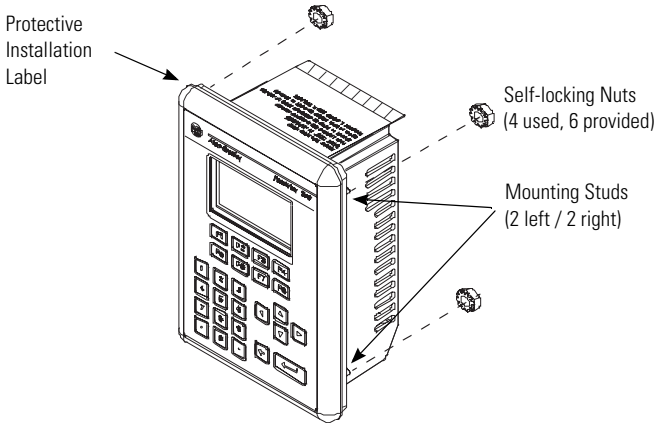

6. Alternately tighten the self-locking nuts until the terminal is held firmly against the panel. Tighten the nuts to a torque of 1.13 N•m (10 lb•in). Do not overtighten nuts.

ATTENTION



Mounting nuts must be tightened to a torque of 1.13 N•m (10 lb•in) to provide a proper seal and to prevent potential damage to the terminal. Allen-Bradley assumes no responsibility for water or chemical damage to the terminal or other equipment within the enclosure because of improper installation.

-
7. Remove the protective installation label covering the top vents of the terminal.

ATTENTION



Failure to remove the protective installation label covering the top vents could result in overheating and damage to the terminal.

Installing the Memory Card Retainer

The memory card retainer is required for UL508 installations where a memory card is inserted in the card slot. The retainer protects against Electrostatic Discharge (ESD) up to 15KV and prevents accidental removal of a memory card in high vibration environments.

To attach the memory card retainer:

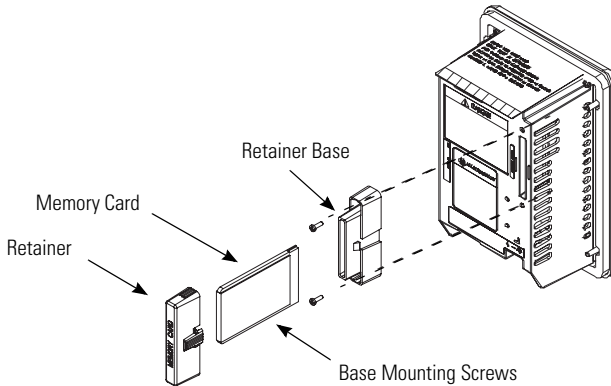

1. Secure the base of the retainer over the existing memory card slot using the two screws provided. Tighten screws to a torque of $0.7 \dots 0.9 \text{ N}\cdot\text{m}$ ($6 \dots 8 \text{ lb}\cdot\text{in}$).
2. Insert the memory card and install the retainer until it is properly seated.
3. To remove the retainer, press the tabs on each side and pull.

Connecting DC Power

All of the PV300 terminals (Catalog No. 2711-K3AxxL1) connect to a 24V DC power source.

The table below shows the electrical ratings for the DC versions of the terminals. Electronic circuitry and an internal fuse protect the terminals from reverse polarity and over-voltage conditions.

Terminal Type	Supply Voltage	Power Consumption
PV300 Keypad	18...32V DC, (24V DC nominal), Class 2 Power Supply	6 Watts (0.25 Amps at 24V DC)

The PanelView 300 terminal is designed for safe use when installed in a suitably rated NEMA Type 12, 13, 4X (indoor use only), IP54 or IP65 enclosure.

ATTENTION



Do not connect the PanelView terminal to an AC power source. Connecting to an AC power source may damage the terminal.

ATTENTION



Use only a Safety Extra Low-Voltage (SELV) power supply as a source for the PanelView 300 terminal. A SELV power supply does not exceed 42.4V DC.

To connect DC power to the PV300 keypad terminal:

1. Secure the DC power wires to the terminal block screws.

IMPORTANT

The terminals are rated for 30 - 14 AWG copper wire. Tighten to 0.57 N•m (5 lb•in).

- Secure the Earth Ground wire to the correct terminal block screw.

ATTENTION

Explosion Hazard - Do not connect or disconnect equipment while circuit is live unless area is known to be non-hazardous.

Do not apply power to the terminal until all wiring connections have been made. Failure to do so may result in electrical shock.

- Apply 24V DC power to the terminal.

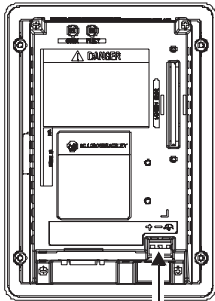

Power Terminal
Block (fixed)

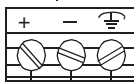

Earth Ground
DC Negative
DC Positive

Battery Removal and Disposal

The terminal contains a lithium battery, which is intended to be replaced during the life of the product.

ATTENTION

The clock module contains lithium. Do not dispose of the battery in a fire or incinerator, or the clock module may explode. Follow disposal regulations in your area for lithium battery disposal.

IMPORTANT

The 2711-K3A5L1K terminal is the conformal coated version, which has the battery sealed. It cannot be replaced.



At the end of its life, the battery contained in this product should be collected separately from any unsorted municipal waste.

Follow these steps to remove or replace the battery.

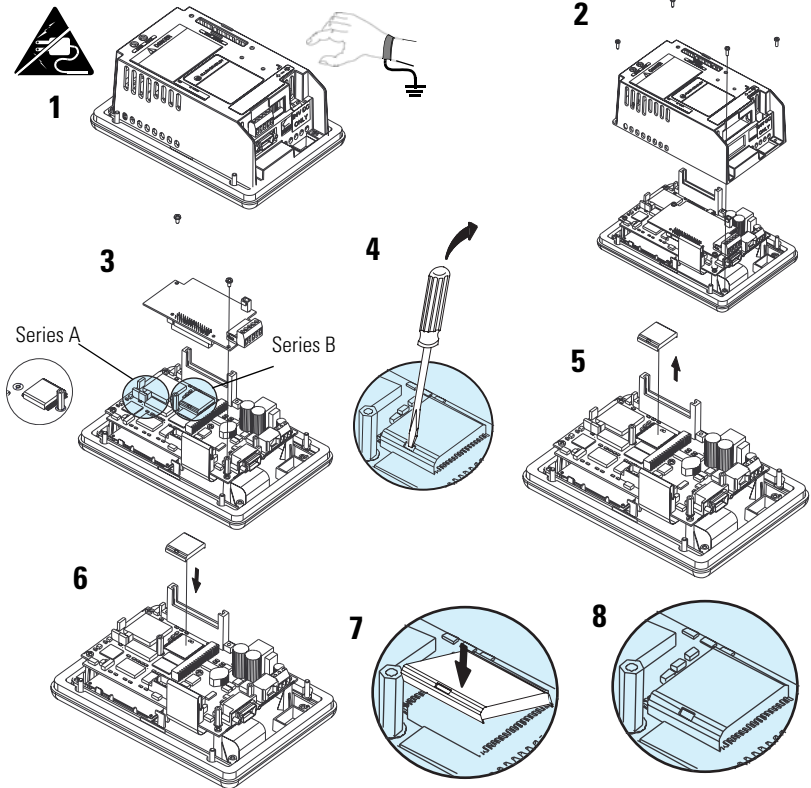

PanelView, PanelView 300, Allen-Bradley, and Rockwell Automation are trademarks of Rockwell Automation, Inc.

Trademarks not belonging to Rockwell Automation are property of their respective companies.

www.rockwellautomation.com

Power, Control and Information Solutions Headquarters

Americas: Rockwell Automation, 1201 South Second Street, Milwaukee, WI 53204-2496 USA, Tel: (1) 414.382.2000, Fax: (1) 414.382.4444

Europe/Middle East/Africa: Rockwell Automation, Vorstlaan/Boulevard du Souverain 36, 1170 Brussels, Belgium, Tel: (32) 2 663 0600, Fax: (32) 2 663 0640

Asia Pacific: Rockwell Automation, Level 14, Core F, Cyberport 3, 100 Cyberport Road, Hong Kong, Tel: (852) 2887 4788, Fax: (852) 2508 1846

Publication 2711-IN027C-EN-P - February 2009

Supersedes Publication 2711-IN027B-MU-P - August 2003

Copyright © 2009 Rockwell Automation, Inc. All rights reserved. Printed in the U.S.A.