

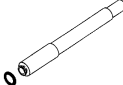









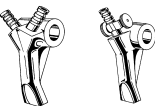
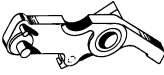

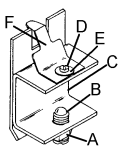







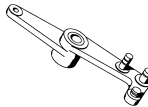
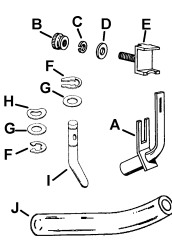

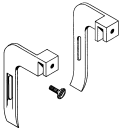
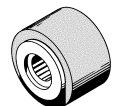

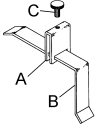

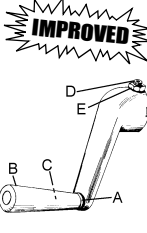



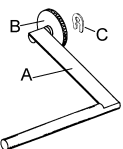

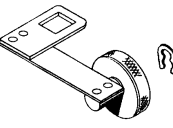

Replacement parts for : MULTI 1210, 1250OS, 1250W, 1250N, 1250DOM., 1215CD,

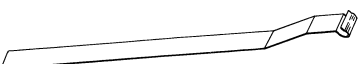
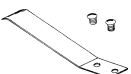
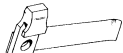
	PART #	PRICE		PART #	PRICE
	VARIABLE SPEED PULLEY 1250 O.S. - 1/2" Shaft P-1629 1250 N.S. - 5/8" Shaft P-1649			SUCKER TUBE - 1650 P-16174 O-RING For sucker tube P-5329	
	V-BELTS 35" Motor to printing head P-4904 33" Pump to motor compound pulley P-1689 32" Compound pulley to machine P-1688 30" Compound pulley to machine P-1686 26" To machine P-4903 49" Conveyor drive P-1690 34" New style pump to motor P-1695			SUCTION FEET Double stem P-12170 Single stem P-12990	
	RATCHET PAWL ARM ASSEMBLY P-12979			PILOT SCREW P-12104	
	SHEET SEPARATOR BRACKET ASSEMBLY Complete P-12112 (A) Nut P-497 (B) Ball retainer P-1105 (C) Bracket P-12113 (D) Screw P-149 (E) Washer P-557 (F) Sheet separator P-12114			COMPENSATING SUCKER TUBE ASSEMBLY <i>EXTENDS 1/4" FURTHER.</i> *** <i>Excellent for running envelopes and heavy stock.</i> 1250 (Set of 2 w / block) P-12259 1250 (Tube only) P-12966 1850 (Set of 3 tubes only) P-18990 1870 (Set of 4 tubes only) P-18170	
	SHEET SEPARATOR - 1360 P-13114			FLAT DISC SUCKER FOOT P-1552	
	SHEET SEPARATOR For TOKO 1218 P-128114			SUCKER FOOT For Multilith 1218 & for Toko 4700, 4750 P-5203	
	KNOB - Suction & blower 1250 & 1850 P-18074			PAWL LEVER For single sheet feed 1330, 1360, 1650, 1860, 1960 P-13563	
	CENTER BLOWER BRACKET P-12164			DRIVE LEVER ARM ASSEMBLY *** <i>Made of 1/4" solid cast stock for longer life and durability.</i> 1250 P-12927 1330, 1360 P-13927 1650 P-16927 1850 P-18927	
	CENTER BLOWER KIT Complete P-5065 (A) Center blower P-12128 (B) Thumb nut P-537 (C) Lockwasher P-624 (D) Washer P-566 (E) Bracket P-12164 (F) Retaining ring P-668 (G) Washer P-586 (H) Spring washer P-653 (I) Valve stem P-12069 (J) Hose - 27" P-5285			FEEDER LINKAGE DRIVE LEVER (near delivery) P-12732	
	PAPER FEED GUIDE - 1250 O.S. Operators side L.H. P-12088 Non-operators side R.H. P-12099			FEEDER PULLOUT ROLLER Roller with bearing P-12125 Bearing only P-1371 Spacer (on sides) P-12536 Spring P-12181	
	THUMB SCREW P-311			SPRING For feeder pullout roller P-12386	
	PAPER GUIDE AND CLAMP - 1250 Center Guide (A) Clamp P-12049 (B) Adjusting stop P-12048 (C) Thumb screw P-1025			UPPER FEED ROLL HOLDER 1250 N.S. P-12115 1250 O.S. P-12274	
	HOSE For sucker foot (14") P-5269			HAND CRANK ASSEMBLY *** <i>Made of solid white brass which helps prevent stripping.</i> Complete P-12955 (A) Stud P-36962 (B) Handle P-36961 (C) Spring lock P-36959 (D) Screw P-874 (E) Nut P-492 (F) Spring P-12909 (G) Steel ball P-755	
				TABLE PAWL RELEASE LEVER 1250 P-12969 1330, 1360, 1650 P-13969	

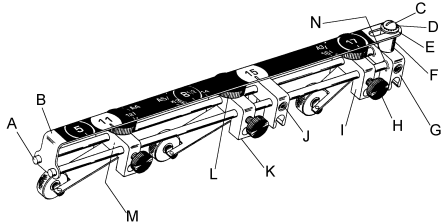

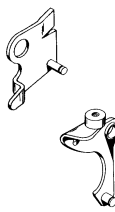

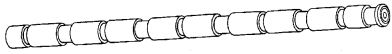
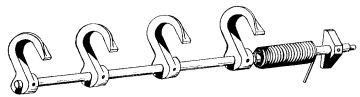
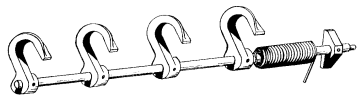
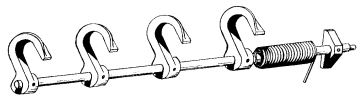
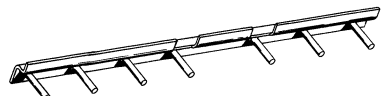

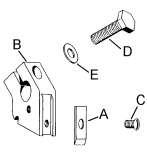
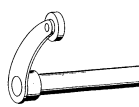

2650, 2850, 4150, 4250, 1330, 1360, 1315CD, 1650, 1820, 1860, 1870, 1960

	PART #	PRICE
	CONVEYOR DRIVE SPROCKETS - O.S. Front feed roller P-12555 Rear feed roller P-12559	
	TENSION SPROCKET	P-12522
	CONVEYOR TIMING PULLEY - N.S. -Conveyor roller P-4242 CONVEYOR TIMING PULLEY - N.S. -Front feed roller P-4257 CONVEYOR DRIVE PULLEY - N.S. -Rear feed roller P-4258	
	(P-4242)	
	TENSION ROLLER	P-12425
	SKID ROLLER ASSEMBLY Works with P-12359 shown below. Narrow wheel 1250 P-12434 (A) Arm P-12436 (B) Roller P-12454 (C) C-ring P-680 Wide wheel 1850 P-18434 (A) Arm P-12436 (B) Roller P-12532 (C) C-ring P-680 (D) Bushing (comes with Roller P-12532) P-799	
	THUMB SCREW	P-311
	SKID WHEEL HOLDER	P-12359
	SKID ROLLER ASSEMBLY For old design skid wheels that uses posts. Complete 1250 P-12501 Arm only P-14492 Wheel only P-12532 Bushing (included w/ P-12532) P-799 C-ring P-680	
	GUIDE ASSEMBLY - 1360	P-13403
	CONVEYOR TAPE - 1275 Tandem 49-3/16" X 1/2" P-3904	
	CONVEYOR FEED TAPES Regular plastic P-4957 Special cloth for easier feeding P-4955	
	CONVEYOR PAPER RETAINER	P-12433
	PAPER GUIDE SPRING 1250 P-12924 SCREW P-191	
	PAPER GUIDE SPRING - 1850 & 1860	P-18527
	TAPE BAR	P-12708

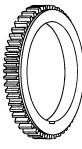
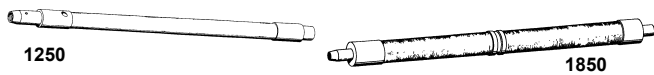
	PART #	PRICE
	REGISTER BAR ASSEMBLY (Complete)	P-13703
	(A) Support rod P-13483 (B) Register bar with scale P-13359 (C) Screw P-225 (D) Lockwasher P-635 (E) Washer (comp. assm. takes 2) P-1811 (F) Spacer P-1415 (G) Adjusting block (comp. assm. takes 2) P-13497 (H) Thumb screw (comp. assm. takes 3) P-7220 (I) Skid roller and block assm. - short P-13492 (J) Set screw P-18 (K) Skid roller and block assm. - long P-13434 (L) Thumb screw P-1807 (M) Brass plug (short) P-11795 (N) Retaining ring P-698 (O) Brass plug (long) for thumb screw "H" P-4788	
	SPECIAL MICRO ADJUSTING NUT & STOP For upper feed roll adjustment P-12135 ... NO TOOL NEEDED FOR FAST & EASY ADJUSTMENT!	
	FEELER FINGER PILOT SCREW	P-12141 P-3073
	PAPER FEED FRAME LEVERS 1250 Old design (straight, no tab) P-12165 1250 O.S. & L.W. (straight, with tab) P-12156 1250 N & DOM. (bent, with tab) P-12151 1650 (straight) P-16156 1650 (bent) P-16151	
	CAM LEVER 1250 P-12155 1650 P-16155	
	FEED FRAME ROLLER 1250 P-12157 1330, 1360, 1650 P-13157	
	FOUR FINGER SHAFT ASSEMBLY -Complete 1250 New style (pyramid cam - no notch) P-12393 -Complete 1250 Domestic (tear drop cam) P-12387 -Complete 1250 M / MG (notched pyramid cam & tear drop cam) P-12381	
	THREE FINGER SHAFT ASSEMBLY -Complete 1250 Old style P-12388	
	PAPER HOLD ATTACHMENT -Complete 1250 P-12840	
	EJECTOR PIN BAR - Universal for old & new style. 1250 (7 Pin) P-12249	

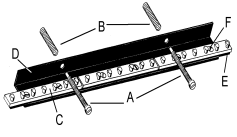

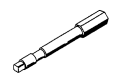

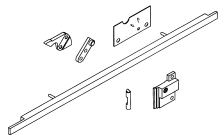

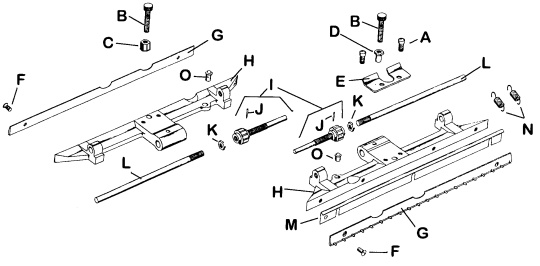
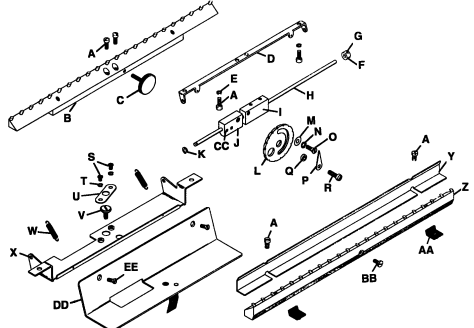

THIS IS JUST A SAMPLE OF OUR TOTAL INVENTORY

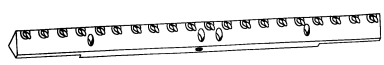
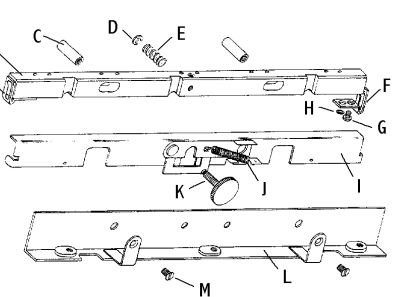
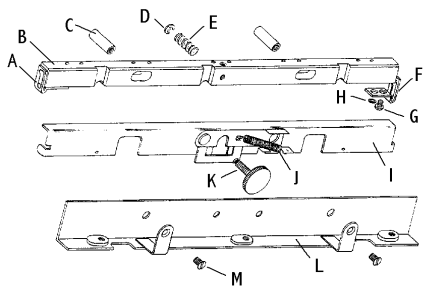
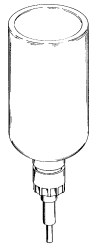



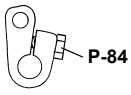
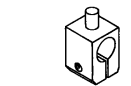





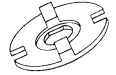

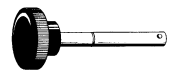
Replacement parts for : MULTI 1210, 1250OS, 1250W, 1250N, 1250DOM., 1215CD,

	PART #	PRICE
	IMPRESSION GRIPPER HOLDER ASSEMBLY	
	Complete	P-12182
	(A) Finger O.S.	P-12245
	(A) Finger N.S.	P-12237
	(B) Holder	P-12189
	(C) Screw	P-12187
(D) Screw	P-96	
(E) Washer	P-586	
	IMPRESSION GRIPPER SHAFT & ARM ASS'Y.	
	Complete	P-12203
	Arm assembly	P-12207
	Shaft only	P-12205
Arm only	P-12197	
	IMPRESSION CYLINDER ADJUSTING SEGMENT	
	P-12733	
	BUSHING For impression cylinder adjustment	
	1850 Non-op. side	P-18400
	CYLINDER GEARS	
	Master (plate)	P-12313
	Blanket	P-12214
	Impression	P-12191
... All gears are hardened for longer life.		
	1250	
	1850	
BLANKET CYLINDER SHAFTS		
1250 (.750 Dia.)	P-12290	
1250 (.010 Oversized dia.)	P-12302	
1330, 1360, 1650 (.1.125 Dia.)	P-13290	
1330, 1360, 1650 (.030 Oversized dia.)	P-13302	
1850 (1.125 Dia.)	P-18290	
1850 (.030 Oversized dia.)	P-18302	
	CAM BAND - 1250 O.S. & N.S.	
	For blanket cylinder	P-12178
	BLANKET CYLINDER CLAMP KIT	
	Complete (Trailing 11x17)P-14258	
	(A) Screw	P-12204
	(B) Spring	P-12390
	(C) Pin bar	P-12922
	(D) Bracket	P-14003
	(E) Nut bar	P-14004
(F) Screw	P-12921	
	MASTER CYLINDER ADJUSTING WRENCH	
	1250 O.S.	P-12266
	1250 N.S.	P-12236
	1360 (13" clamps)	P-13266
	1360 (16-1/2" clamps)	P-13236
	1960	P-19236
	MASTER CYLINDER CLAMP LOCK LINK	
	1330, 1360, 1650	P-13299
	MASTER CYLINDER UPGRADE KIT	
	1650	P-13385

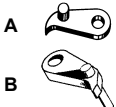

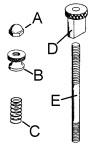
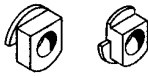
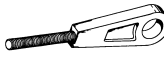

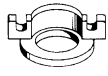



	PART #	PRICE
	1250 (10 X 15) MASTER CYLINDER ASSEMBLIES	
	Lead Edge - complete	P-12788
	(A) Screw	P-159
	(B) Thumb screw	P-1095
	(C) Nut (used on P-12788 only)	P-1898
	(D) Nut (used on P-12790 only)	P-12796
	(E) Handle (used on P-12790 only)	P-12761
	(F) Screw	P-12770
	(G) Pin bar (18 point*)	P-12760
	(H) Clamp only - not sold alone	-----
	(I) Adjusting screw	P-12812
	(J) Taper pin	P-421
	(K) Nut	P-497
	(L) Stem	P-12793
(M) Retainer (used on P-12790 only)	P-12797	
(N) Spring (used on P-12790 only)	P-12762	
	16-1/2" ANGULAR ADJUSTING CLAMP ASSEMBLY	
	Complete (1250)	P-12702
	Complete (1360, 1650)	P-13702
	Sub assy. - items (A) - (CC) (1250)	P-12717
	Sub assy. - items (A) - (CC) (1360, 1650)	P-13717
	(A) Screw	P-161
	(B) Pin bar (tail) - 22 point	P-12746
	(C) Thumb screw	P-1067
	(D) Bracket	P-12729
	(E) Lockwasher	P-624
	(F) Collar	P-927
	(G) Set screw	P-3
	(H) Shaft	P-12726
	(I) Lateral adjusting block	P-12736
	(J) Adjusting block	P-12734
	(K) Retaining ring	P-664
	(L) Adjusting wheel	P-12744
(M) Washer	P-1887	
(N) Spring washer	P-650	
(O) Shoulder screw	P-8090	
(P) Pointer	P-12745	
(Q) Spacer cam	P-1402	
(R) Screw	P-172	
(S) Screw	P-191	
(T) Lockwasher	P-623	
(U) Retainer	P-12738	
(V) Shoulder screw	P-8089	
(W) Spring	P-12724	
(X) Bracket (1250)	P-12716	
(Y) Lead retainer	P-12751	
(Z) Pin bar - (lead) 22 point	P-12739	
(AA) Clip nut	P-12749	
(BB) Screw	P-303	
(CC) Set screw	P-1089	
(DD) Shelf	P-12705	
(DD) Shelf (1360, 1650)	P-13705	
(EE) Screw	P-12375	

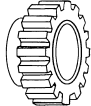

2650, 2850, 4150, 4250, 1330, 1360, 1315CD, 1650, 1820, 1860, 1870, 1960

	PART #	PRICE
	ACTUATING TOOL For plate cylinder latch 1330, 1360, 1650 P-5888	
	PIN BAR CLAMP Master cylinder (10 X 15) 18 Point - 10" long P-12760	
	CLAMP Blanket cylinder 17 Point - 9-3/4" long P-12922	
		
CLAMP - Trail End	P-13790	
(A) R.H. Bracket	P-13377	
(B) Clamp	P-13389	
(C) Special Nut	P-11991	
(D) Retaining Ring	P-666	
(E) Spring	P-13724	
(F) L.H. Bracket	P-13379	
(G) Round Head Screw	P-194	
(H) Lockwasher	P-623	
(I) Pin Bar with Lever	P-13323	
(J) Spring-Extension	P-13309	
(K) Thumb Screw	P-11783	
(L) Support	P-16357	
(M) Flat Head Screw	P-652	
	BOTTLE, CAP & ADAPTER 1250 N.S., 1360, 1850, 1962 (Bottle sits in black plastic receptacle on side of water frame)	
1 Quart assembly	P-1912	
2 Quart assembly	P-1921	
	BOTTLE, CAP & ADAPTER 1250 O.S. (Bottle sits directly in water fountain)	
1 Quart assembly	P-1911	
2 Quart assembly	P-1920	
	PLASTIC BOTTLE RECEPTACLE VALVE P-12347	
	WATER FOUNTAIN HOSE 1250, 1850 O.S. (10-1/2") P-1189 1850 N.S. (19") P-1181	
	WATER DUCTOR PIVOT ARM - 1250 N.S., LW (11X17) 3/8" Bore P-12322	
	WATER DUCTOR PIVOT ARM - 1250 O.S. (10 X 15) 7/16" Bore P-12535	
	SCREW - O.S. & N.S. P-84	
	EQUALIZER PIVOT - 1330, 1360 P-13322	
	PIVOT HOUSING ASSEMBLY - 1330, 1360 P-13535	

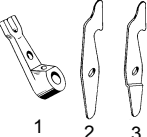
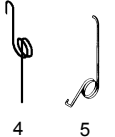
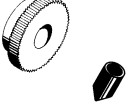

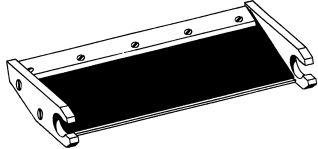

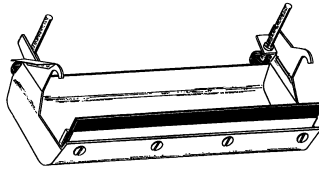

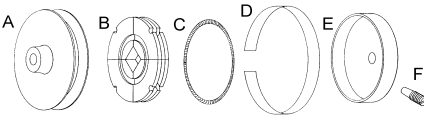
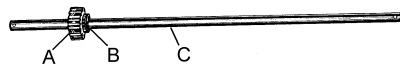
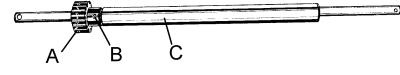
	PART #	PRICE
	DRIVE DISC For water form roller P-12419	
	NIGHT LATCH KNOB P-12493	
	SHAFT For water oscillator roller 1250 P-12378	
	PIN ASSEMBLY For water fountain roller Short 1-7/8" shaft P-12688 Medium 2-1/8" shaft P-12687 Long 3-3/16" shaft P-12691	
	COLLAR (For pin assembly listed above) 1/2" for short pin P-12371 7/8" for long/medium pin P-12370	
	SHAFT For water fountain roller P-12402	
	DRIVE COLLAR For Water fountain roller ... Made of steel for longer life. For non-operators side P-12417 SCREW P-840	
	A PAWL - Water / Ink ratchet P-12268 (A) 1250	
	B PAWL - Water / Ink ratchet (B) 1330, 1360, 1650, 1850, 1960 P-13268	
	RETAINER For water oscillating roller (A) Hex cap nut P-470 (B) Thumb nut P-538 (C) Spring P-12413 (D) Retainer P-12560 (E) Stud (stem) P-7053	
	BEARINGS For "Multi Flow" Water oscillator. Operators side P-5770 Non-operators side P-5775	
	ADJUSTING LINK ASSEMBLY 1820 Second Head P-1822808	
	ECCENTRIC ADJUSTMENT BUSHING For print head adjustment New style w/ 7/8" dia. hub P-13825	
	BEARING SHIELD (need 2) For lower ink form roller on 1820 second color head P-1820000	
	INK FORM ROLLER KNOBS Upper ink form P-12489 Lower ink form P-12491 Water form P-12405 SET SCREW (all knobs) P-8	
	SEPARATING CAM For ink form roller 1250 O.S. (10 X 15) P-12864 1250 N.S. (11 X 17) P-12451 TAPER PIN O.S. P-441 TAPER PIN N.S. P-439	



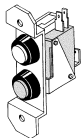
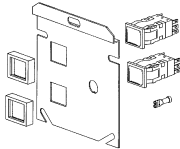

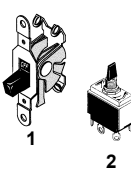
Replacement parts for : MULTI 1210, 1250OS, 1250W, 1250N, 1250DOM., 1215CD,

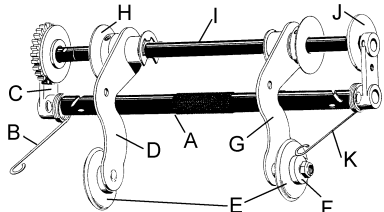
	PART #	PRICE
	IDLER GEAR - Bushing included 1250 O.S. (10 X 15) P-12455 1250 N.S. (11 X 17) P-12446	
	BUSHING	P-1236
	DOG For oscillating rollers (A) Water P-12428 (B) Ink P-12463	
	WORM For ink & water oscillating rollers P-12464	
	HOLD DOWN SCREW	P-12494
	IDLER ROLLER BUSHING - 1650 P-11411	
	ROLLER SUPPORT 1330, 1360	P-13915
	INK & WATER DUCTOR ARM 1250 N.S. (steel) P-12321 INK & WATER DUCTOR LATCH 1250 N.S. P-12338	
	1) INK & WATER DUCTOR ARM 1250 O.S. (Brass) P-12607 2) INK DUCTOR LATCH No bend 1250 O.S. (LH. & R.H.) P-12546 1850 P-18546	
	3) INK DUCTOR LATCH - With bend 1250 W (R.H.) P-14546 1250 W (L.H.) P-14338 4) RIGHT HAND SPRING - Ink & water ductor latch 1250 O.S. (10 X 15) P-12575 1250 N.S. (11 X 17) P-12336 5) LEFT HAND SPRING - Ink & water ductor latch 1250 O.S. (10 X 15) P-12551 1250 N.S. (11 X 17) P-12331	
	INK & WATER RATCHET WHEEL 1250, 1850 P-12239 1960 P-19239 SNUBBER - Ink & water ratchet lever P-7058	
	COMPOUND PULLEY	P-4259
	INK FOUNTAIN ASSEMBLY - 1250 O.S. & N.S. *** Designed with replaceable end caps & deeper well for 50% more ink capacity.	
	Complete P-12778 Fountain only P-12789 Thumb screw (14 total) P-1570 Wire P-35084 Clamp P-12082 Screw for clamp P-12907 Blade 1250 (10-1/4" X 1-3/4") P-12079 Blade 1250 (10-1/4" X 3") P-12233	
	INK FOUNTAIN BLADE 1650 P-16233 1960 P-19079 Blade 1850 only P-18079	

	PART #	PRICE
	INK WASH UP ATTACHMENT *** Universal for old & new style.	
	1250 O.S., W, LW (10 X 15 & 11 X 17)	P-12773
	WASH UP BLADE *Fits our wash up attachment only.	P-5030
	CLUTCH WEIGHT - 1360	P-13593
	CLUTCH PULLEY ASSEMBLY	
	Complete 1250 P-14001 Complete 1850 P-18001 (A) Pulley only 1250 P-12587 (A) Pulley only 1850 P-18587 (B) Clutch shoe (set of 4) P-12593 (C) Spring P-12591 (D) Liner P-5061 (E) Clutch drum 1250 P-12617 (E) Clutch drum 1850 P-18617 (F) Pilot screw P-7069	
	OLD STYLE DRIVE SHAFT ASSEMBLY	
	Complete P-12835 (A) Pinion gear - (black-stamped "O") P-12854 (B) Taper pin P-435 (C) Drive shaft P-12869	
	Complete P-12837 (A) Pinion gear - (silver) P-12865 (B) Taper pin P-435 (C) Drive shaft (only) P-12869	
	PILOT SCREW For pulley - both styles	P-8068
	NEW STYLE DRIVE SHAFT ASSEMBLY With long shank gear. For use with hardened cylinder gears.	
	Complete P-12577 (A) New style gear P-12581 (B) Taper pin P-435 (C) Drive shaft P-12583	
	PILOT SCREW For pulley	P-8067
	DRIVE SHAFT ASSEMBLY - 1360, 1650	
	Complete P-13837 (A) Pinion gear P-13581 (B) Taper pin P-435 (C) Drive shaft P-13869	

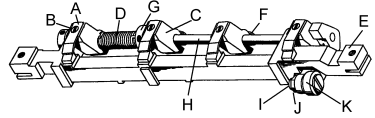
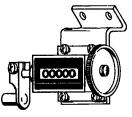
2650, 2850, 4150, 4250, 1330, 1360, 1315CD, 1650, 1820, 1860, 1870, 1960

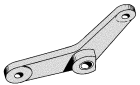
	PART #	PRICE
 <p>SWITCH ASSEMBLY Complete Start (green) 1250 N.S. Stop (red) 1250 N.S.</p>	P-12566 P-12829 P-4062	
 <p>SWITCH REPLACEMENT KIT 1330, 1360 Consists of: 1 ea. stop switch (red) & start switch (green), 1 mounting plate, 2 switch holders, 10 wire terminals. Also includes installation instructions.</p>	P-9828	
 <p>PUMP SWITCH 1330, 1360</p>	P-4470	
 <p>(1) TOGGLE SWITCH For drive motor & pump (includes screws) 1250 O.S.</p> <p>(2) MOMENTARY TOGGLE SWITCH 1250 L.W.</p>	P-12305 P-4055	
 <p>WIRE MOUNTING SCREWS For P-12305 1250 O.S.</p>	P-252	
 <p>"QUICK CHANGE" UPPER EJECTOR ROLLER ASSEMBLY ... Adjustable, gear driven with a knurled shaft for quick removal and easy access.</p>	P-12616 P-12558 P-12604 P-12584 P-12612 P-12600 P-1444 P-12611 P-12621 P-12782 P-12590 P-12618	
 <p>GRIPPER BAR CHAINS 1250 (53-3/4" long X 1/2" wide) 1850 (54-1/4" long X 1/2" wide) Carrier link - 1250, 1850</p> <p>For Press Specialties chain delivery - N.S. (51-1/4" long X 1/2" wide)</p> <p>For Press Specialties chain delivery - O.S. (50-3/4" long X 7/16" wide)</p> <p>Gripper chain - TOKO 1218 Carrier link - TOKO 1218</p>	P-121100 P-181100 P-9406 P-8944 P-8933 P-8971 P-8736	

	PART #	PRICE
 <p>GRIPPER BAR ASSEMBLY (WITH BRASS COLORED ANVIL) ... MADE OF YELLOW BRASS FOR HIGHER TENSILE STRENGTH.</p>	P-120990 P-130990 P-180990 P-190990 P-121020 P-12187 P-121061 P-121080 P-121090 P-131090 P-181090 P-191090 P-44 P-734 P-121010 P-181010 P-4600 P-522 P-1447	
<p>GRIPPER BAR REPAIR KIT Consists of the most commonly replaceable parts on your gripper bar assembly. (Less anvil & shaft) For Multilith style gripper bars only</p>	1250, 1360 P-30733	
<p>GRIPPER BAR REPAIR KITS For Press Specialties Consists of the most commonly replaceable parts on your gripper bar assembly. (Less anvil & shaft where noted)</p>	1217 (4 finger)* P-30745 1217, 1250 (5 finger)* P-30746 1250 (4 finger)** P-30747 1252* P-30748	
<p>* does not come with shaft or anvil. ** comes with shaft but no anvil.</p>		
 <p>COUNTER With bracket & arm With bracket & no arm Counter only 1250N, 1360</p>	P-12996 P-12954 P-12952	
<p>COUNTER ARM ONLY</p>	P-12942	
 <p>STRIPPER FINGER - 1650 CD (1615)</p>	P-162281	
 <p>BACK JOGGER LEVER ASSEMBLY 1850 CD (1815)</p>	P-181590	
 <p>FLEXIBLE JOGGER SHAFT</p>	P-161920	
<p>... ELIMINATE COSTLY DOWNTIME WITH YOUR OWN EMERGENCY KIT FOR YOUR MODEL PRESS.</p>		
 <p>REPAIR KITS FOR ALL MULTILITHS</p>	Master kit P-1776 - 435 pcs. Junior kit P-30328 - 217 pcs. Nut kit P-1772 - 60 pcs. Screw kit P-1773 - 62 pcs. Pin kit P-1774 - 86 pcs. Spring kit P-1775 - 85 pcs. Washer & ring kit P-1777 - 136 pcs.	