

Tenney

ENVIRONMENTAL

Battery Testing Solutions

- Environmental Chambers
- Walk In Rooms
- Industrial Ovens

PARTNERS IN SAFETY

We Help Create Your Custom Safety Solution

Tenney Environmental uses the most up-to-date technology and engineering to build equipment to test a wide variety of batteries.

- Proprietary Risk Analysis
- Customization for your Application
- NFPA Compliance





BATTERY TESTING SOLUTIONS

Tenney has the environmental testing products and capabilities for applications including automotive, mobile devices, computers, telecommunications, defense and alternative energy.

What do the telecommunications, automotive, computer, defense, and alternative energy markets have in common? They all need a safe and reliable way to test batteries. And with more

electronic devices being used and electric hybrid vehicles hitting the road every day, the ability to test lithium ion batteries has never been more in demand.

MEETS INDUSTRY TESTING STANDARDS SAFELY



- IEC 62660-2 for abuse testing of automotive batteries
- SAE J2464 for automotive rechargeable batteries (RESS systems)
- IEC 60086-4 Safety of lithium batteries
- UL 1642 for lithium ion batteries
- UN/DOT 38.3 for testing lithium ion batteries
- IEC 61960 for portable lithium cells and batteries
- IEC 62133 for portable battery cells
- UL 2054 for consumer and commercial batteries
- IEEE 1625 Laptop Rechargeable batteries
- IEEE 1725 Phone rechargeable batteries

Safely test to all major standards including IEC, SAE, UL, UN/DOT, & IEEE
(Safety options available for all Eucar Listings)

BATTERY CHAMBER

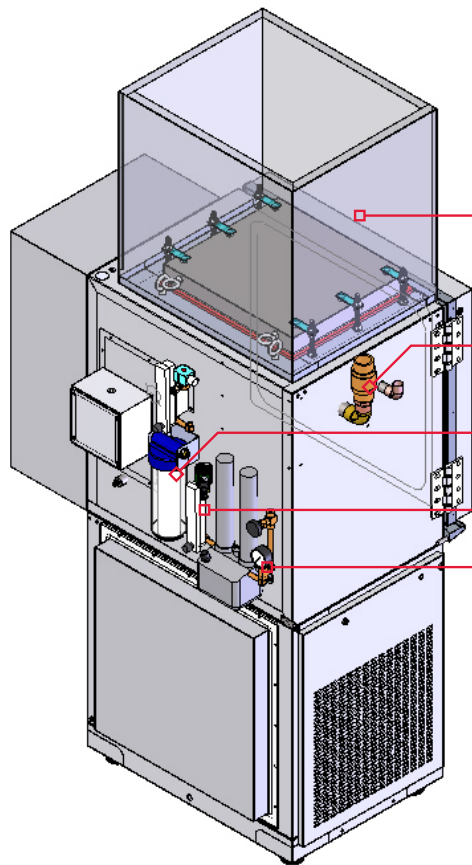

EXPLOSION VENT PANEL

PRESSURE VENT PORT

RAPID PURGE SYSTEM

INERT ATMOSPHERE

CLASS "A" SAFETY
VENTILATION SYSTEM

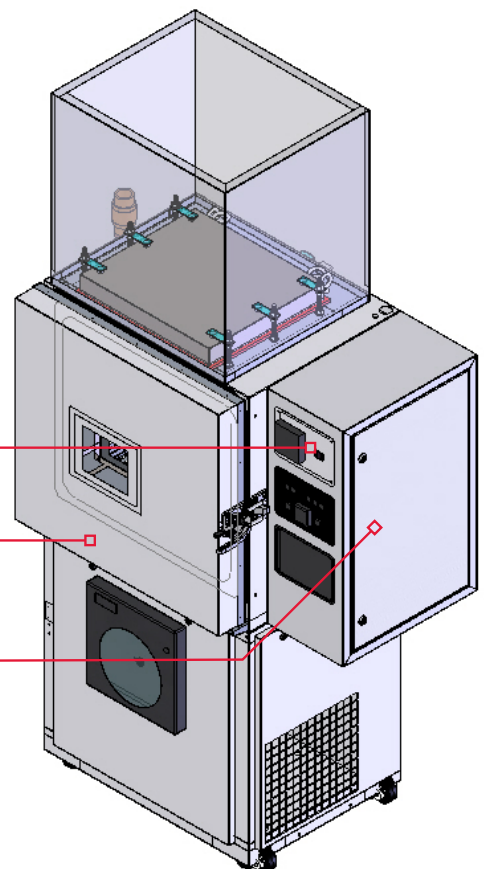

OTP TEMPGUARD IV

REINFORCED CHAMBER
AND DOOR CONSTRUCTION

TEMPERATURE LIMITED
ELECTRIC HEATER



Baseline Capabilities Chambers and Walk In Rooms

- Temperatures Range from -73°C to 200°C
(-100°F to 392°F)
- Humidity Range from 10% to 98%

**Wide Variety of
Internal Dimensions to
Accommodate your Testing
Needs**

**Easy to Use Touchscreen
Control System**

**NFPA Compliant Systems
Tailored to your Specific
Requirements**



SAFETY OPTIONS

Tenney offers a wide range of safety features and options to allow you to meet your testing needs while complying to NFPA safety requirements.

Tenney Engineers are available to partner with you to create the chamber you need—size, features, safety, atmospheres, controllers, exhausts and more.

Put us to the test & test with the best.



Chamber Pressure Alarm (Standard)

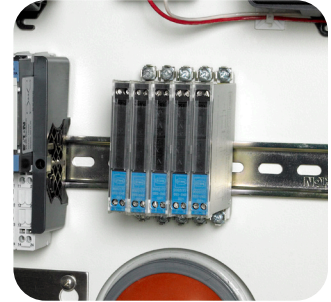

Intrinsic Safety Barriers

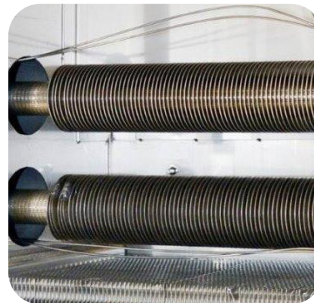

Temperature Limited Electric Heaters



Rapid Purge System



Emergency Stop Control



Heater Surface Temperature Limiters



Redundant Process Temperature High Limit (Standard)



NFPA Class A Ventilation System



Inert Atmosphere (NFPA Compliant)



Solvent Monitor



Gas Analyzers (H₂, O₂, CO₂, CO)



Pressure Relief Ports (Standard)



NFPA Compliant Explosion Venting (Standard)



Remote Shutdown

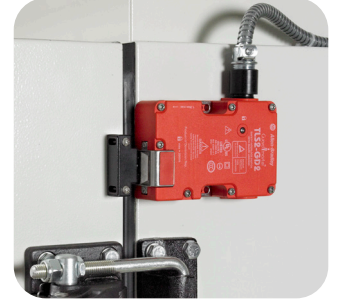

Automatic Door Locks

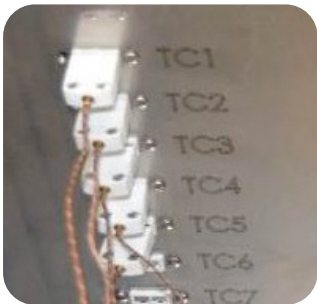

Product Monitoring Thermocouples



Rapid Cryogenic Cooling



Fire Suppression (Water, Halon, CO₂, LN₂)



Alarms (Audible, Visual, Output Contacts)

ABOUT TENNEY ENVIRONMENTAL

Tenney boasts the most comprehensive line of standard and custom environmental test chambers and rooms in the industry. Known for innovative engineering design, robust construction, and superior performance, the Tenney line of test chambers is designed to meet all your temperature, humidity, altitude, vibration, and vacuum-testing requirements. Tenney Environmental is owned by Thermal Product Solutions ("TPS").

www.thermalproductsolutions.com



TPSTM
Thermal Product Solutions

» Baker Furnace » Blue M » Gruenberg » Lindberg/MPH
» Lunaire » Tenney » Wisconsin Oven

Thermal Product Solutions

Baker Furnace, Blue M, Gruenberg, Tenney, Lindberg, Lunaire, MPH, and Wisconsin Oven

Mailing Address: P.O. Box 150 | White Deer, PA 17887-0150 | USA |

Phone: (570) 538-7200 | Fax: (570) 538-7380

Physical Address: 2821 Old Route 15 | New Columbia, PA 17856-9396

info@thermalproductsolutions.com

Specifications and Product Information are subject to change without notice.