

# INSTRUCTION MANUAL

## AZ-GTe Mount

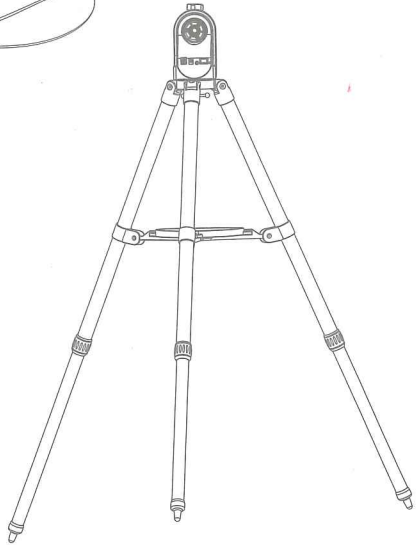
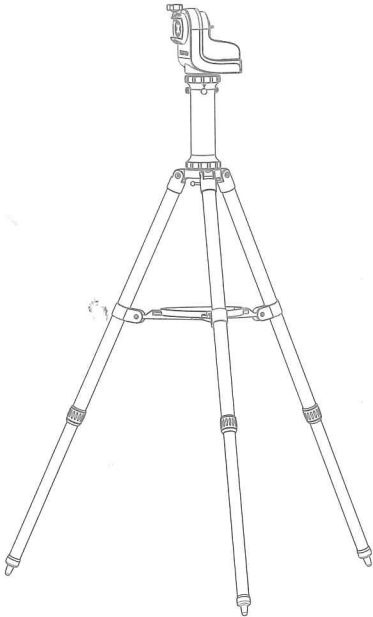
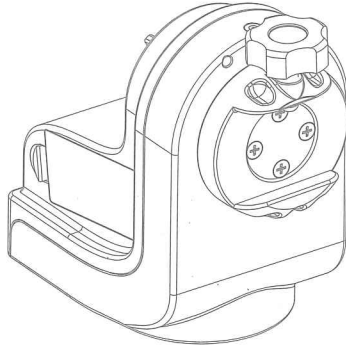

Copyright © Sky-Watcher

# CONTENT

## Parts Diagram

### PART I : SETTING UP THE AZ-GTe MOUNT

1.1 Setting up on a Skywatcher Tripod .....	5
1.2 Attaching the AZ-GTe Mount to a camera tripod .....	6
1.3 Installing the Telescope .....	7

### PART II : ELECTRONIC CONTROL INTERFACE

2.1 Control Panel .....	8
2.2 Panel Interface Components .....	8
2.3 Pinout of The Interfaces .....	9
2.4 DSLR Control Cables .....	9
2.5 Power Supply Requirements .....	9

### PART III : USING THE AZ-GTe MOUNT

3.1 Manually Rotating the Mount .....	10
3.2 Control with a SynScan Hand Control .....	10
3.3 Control with a Mobile Device .....	10
3.4 Wi-Fi Connection .....	10
3.5 Firmware Update .....	10

### PART IV: Assembling Your Telescope

4.1 Finderscope/Red dot finder assembly .....	14
4.2 Eyepiece assembly .....	15

### PART V: Operating Your Telescope

5.1 Aligning and Using the finderscope / red dot finder .....	16
5.2 Focusing the telescope .....	17
5.3 Choosing the appropriate eyepiece .....	18

### PART VI: Observing the sky

6.1 Sky Conditions .....	19
6.2 Selecting an Observing Site .....	19
6.3 Choosing the Best Time to Observe.....	19
6.4 Cooling the Telescope .....	20
6.5 Adapting Your Eyes .....	20

# CONTENT

## PART VII: Proper Care for Your Telescope

7.1 Cleaning Your Telescope .....	21
-----------------------------------	----

## APPENDIX: SPECIFICATIONS

Dimensions .....	22
Specifications .....	22

## Parts Diagram

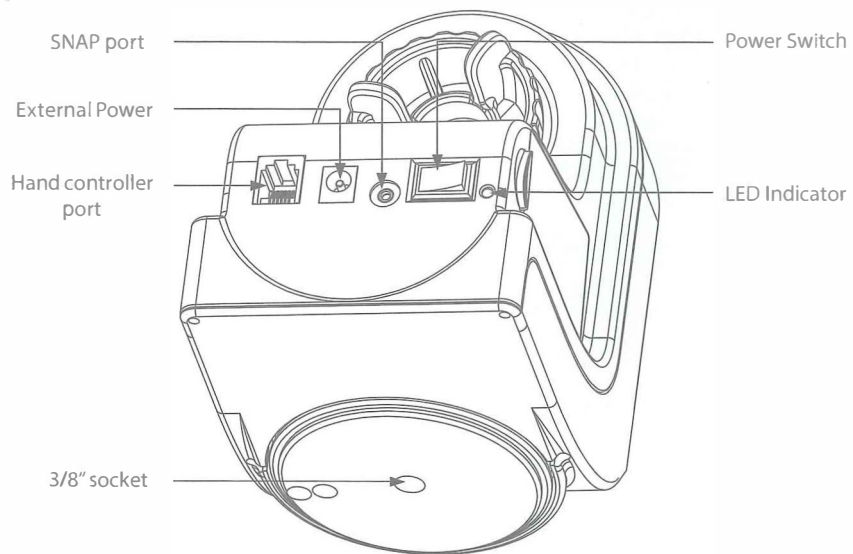
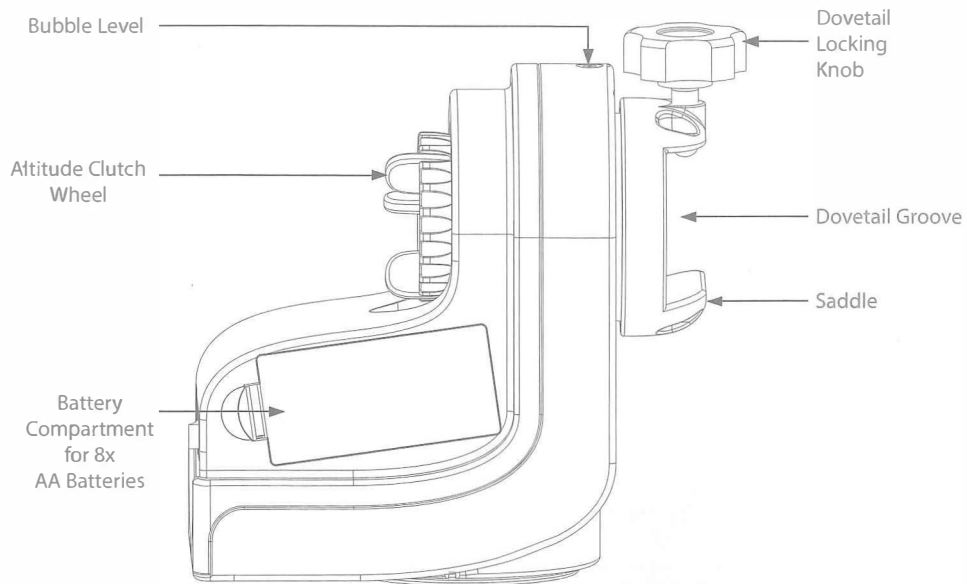

4

## PART I : SETTING UP THE AZ-GTe MOUNT

### 1.1 Setting Up on a Skywatcher Tripod

1. Fully expand the three legs of the tripod on level ground.
2. Install the accessory tray on the tripod as shown in Fig. 1.1a.
3. If using a short tube telescope, which does not hit the tripod legs when it points high up, with the AZ-GTe mount, the mount can be installed onto the tripod directly. Align the 3/8" socket at the base of the mount with the locking bolt on the tripod head. Lock the mount on the tripod by tightening the bolt (Fig. 1.1b).

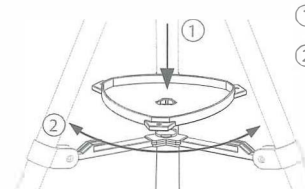

Fig. 1.1a

- ① Align the accessory tray and push down on it while holding onto the bottom supports.
- ② Rotate the tray to lock it into place.

**WARNING:** The accessory tray of a Skywatcher tripod ensures that the tripod legs are firmly expanded, which prevents the tripod from accidentally tipping over. When using the AZ-GTe mount on a Skywatcher tripod, an accessory tray should always be used to ensure stability.

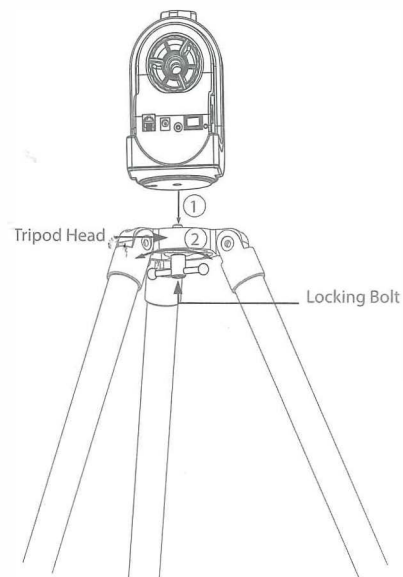
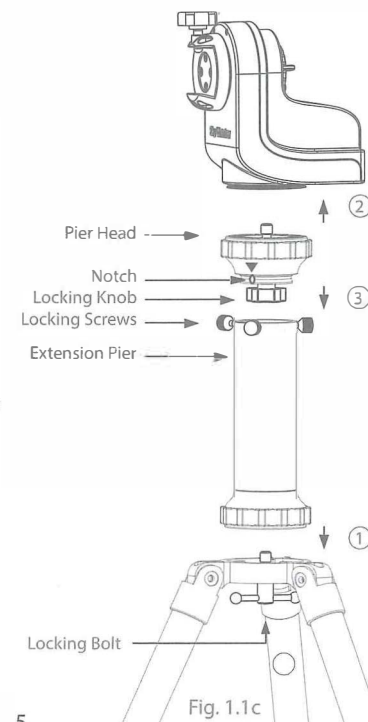

Fig. 1.1b



5

Fig. 1.1c

- If using a long tube telescope with AZ-GTe mount, an extension pier should be inserted between the tripod and the AZ-GTe mount to prevent the telescope from hitting the tripod legs when it points high up (Fig. 1.1c).

- 1) Attach the extension pier to the tripod and tighten the locking bolt.
- 2) Remove the pier head from the extension pier by loosening the three locking screws.
- 3) Attach the pier head to the AZ-GTe mount and tighten the locking knob.
- 4) Place the pier head back on the extension pier, align the notch with one of the three locking screws. Tighten the three locking screws to lock the pier head.

### 1.2 Attaching the AZ-GTe Mount to a Camera Tripod

- Fully expand the legs of the tripod on level ground. Make sure that the tripod is stable.
- Screw the AZ-GTe mount to the 3/8" bolt on the tripod head's mounting plate, tighten the bolt **MODERATELY**.

**Caution:** Over-tightening the mount may cause damage to the internal mechanical parts.

- Most camera tripods' mounting plate comes with 1 to 3 locking screws. Firmly tighten the locking screws from underneath the plate to secure the AZ-GTe mount in place.
- Raise the camera tripod's central pole to the desired height, and make sure that it also prevents the telescope from hitting the tripod legs when the telescope points high up.
- Adjust the lengths of the legs to center the bubble level on the mount.

### 1.3 Installing The Telescope

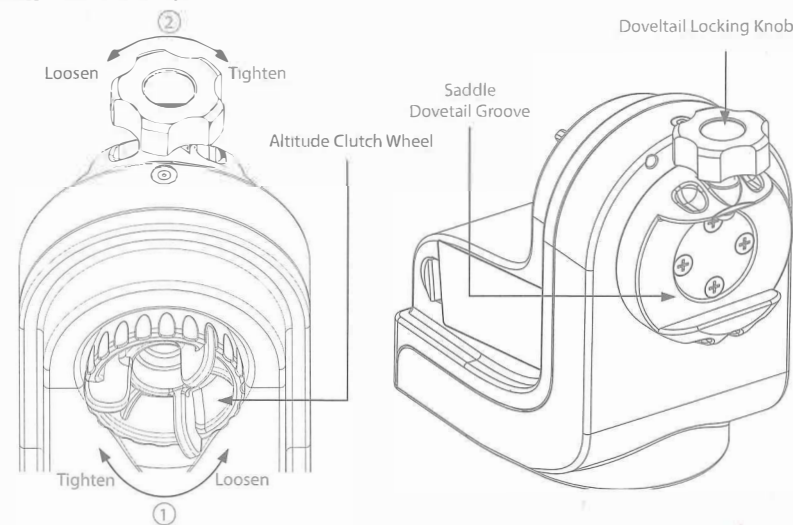

Fig. 1.3a

Fig. 1.3b

- Loosen the altitude clutch wheel and rotate the saddle until the dovetail groove is horizontal, then tighten the altitude clutch wheel again (Fig 1.3a).
- Loosen the dovetail locking knob until nothing is obstructing the dovetail groove in the saddle (Fig 1.3b).
- Hold the telescope horizontally and slide the dovetail bar of the telescope into the dovetail groove of the saddle (Fig 1.3b).
- Tighten the dovetail locking knob until the bar is securely locked in the groove. **DO NOT LET GO OF THE TELESCOPE UNTIL YOU ARE SURE IT IS FIRMLY ATTACHED TO THE SADDLE**
- While holding the telescope tube, fully loosen the altitude clutch to check the balance.
- Repeat the above steps to adjust the position of the dovetail bar back and forth to reach good balance in the altitude axis.

## 2.1 Control Panel

The control panel of the AZ-GTe mount is shown below:

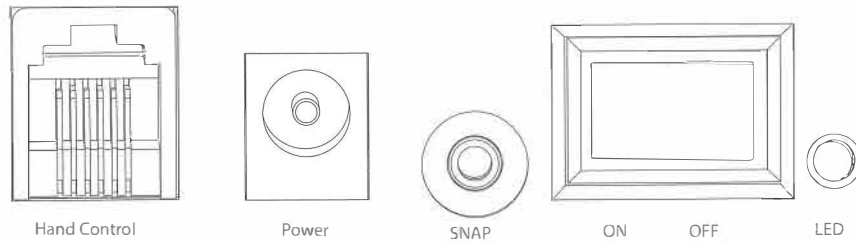
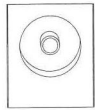
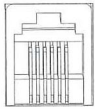

Fig. 2.1

## 2.2 Panel Interface Components:



**POWER:** This is an input for external power to avoid running on the 8 AA batteries in the AZ-GTe mount battery compartment.



**HAND CONTROL:** This RJ-12 6-pins outlet is for connecting the SynScan hand controller.



**SNAP:** This is a stereo jack outlet to connect with a camera's shutter control port. The SynScan hand control can control the camera to take pictures automatically via this interface.

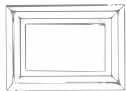

**ON/OFF Switch:** Turns the power to the mount and hand controller on and off.



**Power LED:** The power LED serves as a power-on indicator and provides other statuses.

1. **Steady on:** Internal Wi-Fi is off.
2. **Intermittent one flash:** Internal Wi-Fi is on.
3. **Intermittent two flashes:** App has connected to internal Wi-Fi.
4. **Intermittent three flashes:** Internal control board has entered firmware update mode.

## 2.3 Pinout of The Interfaces:

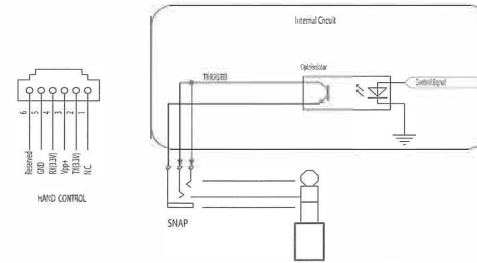

Fig. 2.3

Note:

The SNAP port provides two trigger signals to the stereo plug. For a camera which only needs a shutter-release signal, either trigger signals will work. For a camera which requires an extra "Focus" signal, both signals should be connected properly.

## 2.4 DSLR Control Cable

Available for Canon, Nikon, Olympus and Sony cameras. See the table below to select the appropriate cable for your camera model; it can be ordered from the local Skywatcher dealer.

Part Number	Camera Interface Style	Controller Interface	Compatible Camera Models
AP-R1C	Canon remote (E3 type)	Canon RS-60E3	Canon EOS 100D, 300D/350D, 400D/450D, 500D/550D, 600D/650D, 700D, 60D/60Da, 70D
AP-R3C	Canon remote (N3 type)	Canon RS-80N3, TC-80N3	Canon EOS 5D/6D/7D, 10D/20D/30D/40D/50D, 1V, 1D, 1Ds Mark III, 5D Mark III
AP-R1N	Nikon 10-pin remote terminal	Nikon MC-22, MC-30, MC-36	Nikon D1/D2/D3/D4 D200/D300/D700/D800
AP-R2N	Nikon remote cord connector	Nikon MC-DC1	Nikon D70S, D80
AP-R3N	Nikon accessory terminal	Nikon MC-DC2	Nikon D90, D600, D3000/D3100/D3200/D3300, D5000/D5100/D5200/D5300, D7000/D7100
AP-R1S	Sony remote terminal	Sony RM-S1AM, RM-L1AM	Sony a100, a200, a300, a350, a450, a550, a560, a700, a850, a900
AP-R3L	Olympus multi-connector	RM-UC1	Olympus E-P1/E-P2, E-PL2/E-PL3, E510/E520/E550/E620, E400/E410/E420, SP-570UZ/SP-590UZ

## 2.5 External Power Supply Requirements

- Input Voltage: DC 7.5V (minimum) to DC 14V (maximum). Voltage not in this range might cause permanent damage to the motor controller or the hand controller.
- Input Plug: Barrel type with 2.0mm I.D and 5.5mm O.D. Must be central positive.
- Input Current: At least 750mA.
- Do not use an unregulated AC-to-DC adapter. When choosing an AC adapter, a switching power supply with 12V output voltage and minimum 750mA output current is recommended.
- If the power voltage is too high, the motor controller will stop the motors automatically.

## PART III : USING THE AZ-GTe MOUNT

### 3.1 Manually Rotating The Mount

NEVER try to manually rotate the azimuth axis, it might damage the mount. Always use a SynScan hand control or the SynScan App to rotate the azimuth axis with motor. You can loosen the altitude clutch and manually rotate the altitude axis.

### 3.2 Control with a SynScan Hand Control

Plug in the SynScan hand control into the hand control port in order to control the telescope and mount for astronomical observation. Please refer to the SynScan hand control manual for operation instructions.

### 3.3 Control with an Mobile Device

Users can download the free "SynScan" App from the App Store (for iOS devices) or Google Play (for Android Devices) for astronomical observation. Skywatcher will also provide apps for photography. Please check the stores for availability.

### 3.4 Wi-Fi Connection

- User must connect to the mount's Wi-Fi within 15 minutes after turning on power. The Wi-Fi will be turned off automatically if no connection is established within 15 minutes.
- By default, the SSID of the built-in Wi-Fi is "SynScan\_xxxx" and there is no password. User can download Skywatcher's "SynScan" app from App Store or Google Play to configure the mount's built-in Wi-Fi.
- Reset Wi-Fi configuration to factory default by turning on the power without the SynScan hand control connected and no App operations via the Wi-Fi connection for 4 hours.

### 3.5 Firmware Update

When a new firmware for the control board inside the mount is available, Skywatcher will release it on [www.skywatcher.com](http://www.skywatcher.com). Users can visit this website to download the firmware and the necessary application to update the firmware.

## PART IV: Assembling Your Telescope

### REFRACTOR

- A. Dew Cap/Sun Shade
- B. Telescope Main Tube
- C. Dovetail
- D. Finderscope
- E. Finderscope Bracket
- F. Finderscope Alignment Screws
- G. Focus Locking Screw
- H. Eyepiece
- I. Diagonal
- J. Focus knob

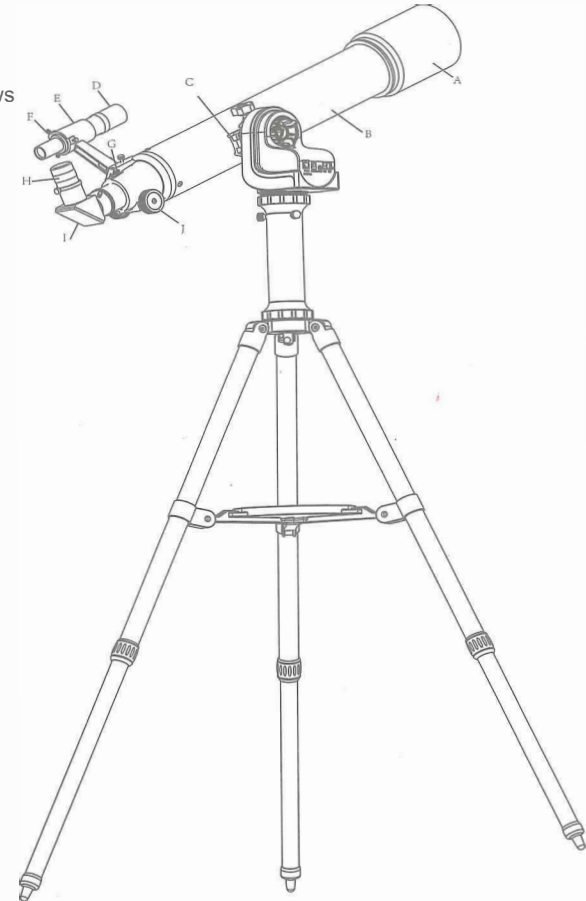

## REFLECTOR

- A. Red Dot Finder
- B. Red Dot Finder Bracket
- C. Telescope Main Tube
- D. Dovetail
- E. Main mirror
- F. Focus knob
- G. Eyepiece

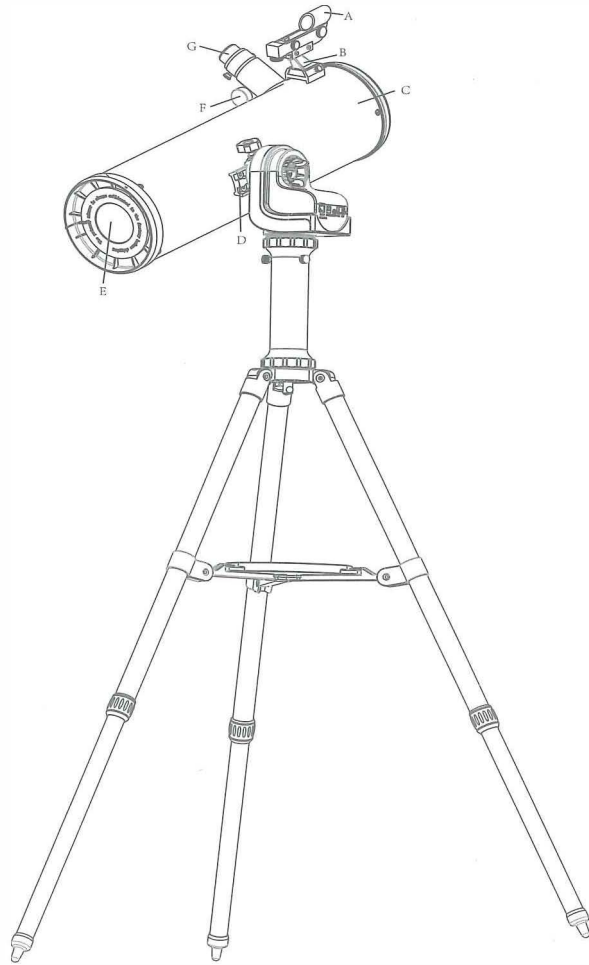

## MAKSUTOV

- A. Dust Cap( not shown, remove before viewing)
- B. Telescope Main Tube
- C. Dovetail
- D. Focus knob
- E. Diagonal
- F. Eyepiece
- G. Red Dot Finder
- H. Red Dot Finder Bracket

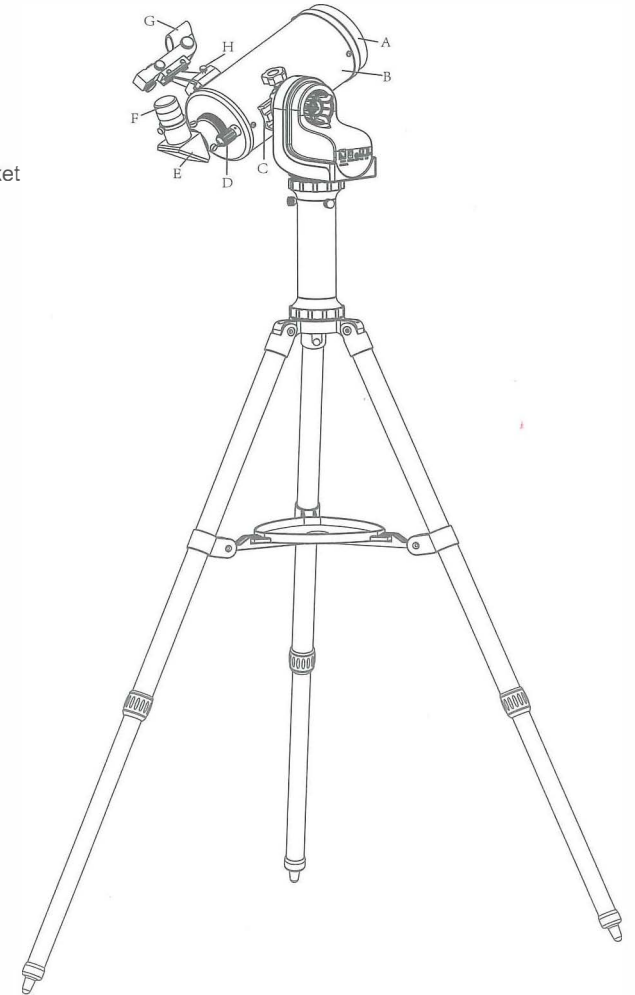

**Before you begin**

This instruction manual is applicable to 3 models. Take a moment to find the model of your telescope. Follow the instructions for your specific model in the manual. Read the entire instructions carefully before beginning. Your telescope should be assembled during daylight hours. Choose a large, open area to work to allow room for all parts to be unpacked.

**4.1 Finderscope/Red dot finder assembly**

## 1. Attaching the finderscope bracket(Fig.4.1.1a)

- Locate the finderscope optical assembly.
- Slide the finderscope bracket into the rectangular slot and tighten the screw to hold the mount in place.

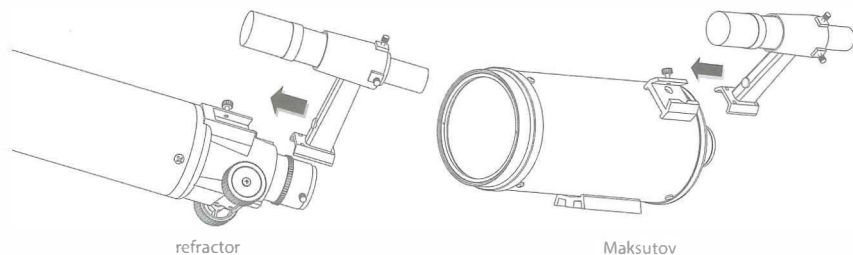

Fig.4.1.1a

## 2. Attaching the red dot finder(Fig.4.1.2a)

- Slide the red dot finder bracket into the rectangular and tighten the screw to hold the red dot finder in place.

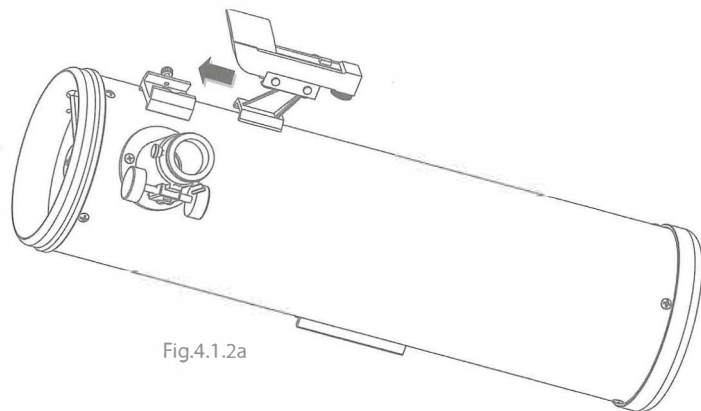

Fig.4.1.2a

**4.2 Eyepiece assembly**

## 1. Inserting eyepiece for refractor and Maksutov(Fig.4.2.1a)

- loosen the thumbscrew on the end of the focus tube.
- Insert the diagonal into the focus tube and re-tighten the thumbscrew to hold the diagonal in place.
- Loose the thumbscrews on the diagonal.
- Insert the desired eyepiece into diagonal and secure by re-tightening thumbscrews.

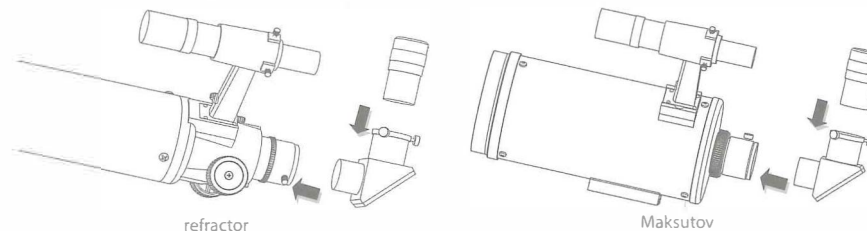

Fig.4.2.1a

## 2. Inserting eyepiece for reflector(Fig.4.2.2a)

- Unscrew the thumbscrews on the end of the focus tube to remove the black plastic end-cap.
- Insert the desired eyepiece then re-tighten thumbscrews to hold the eyepiece in place.

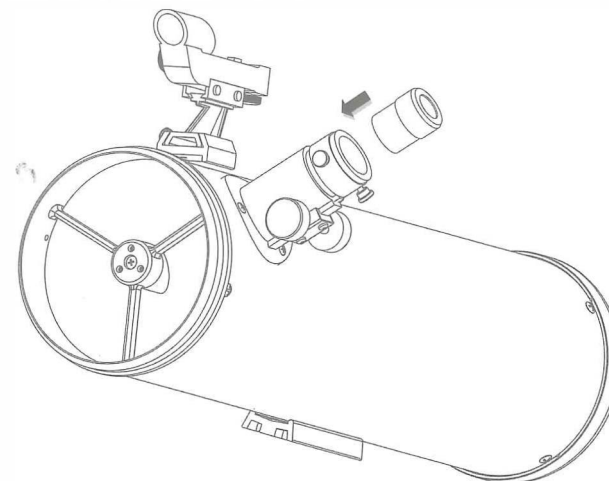

Fig.4.2.2a



## 5.1 Aligning and using the finderscope/red dot finder

### 1. Aligning and using the finderscope

These fixed magnification scopes mounted on the optical tube are very useful accessories. When they are correctly aligned with the telescope, objects can be quickly located and brought to the center of the field. Alignment is best done outdoors in day light when it's easier to locate objects. If it is necessary to refocus your finderscope, sight on an object that is at least 500 meters (or yards) away. For 6x30 finderscope: loosen the locking ring by unscrewing it back towards the bracket. The front lens holder can now be turned in and out to focus. When focus is reached, lock it in position with the locking ring (Fig.5.1.1a).

- Choose a distant object that is at least 500 yards away and point the main telescope at the object. Adjust the telescope so that the object is in the center of the view in your eyepiece.
- Check the finderscope to see if the object centered in the main telescope view is centered on the crosshairs.
- For the 6x30 finderscope with spring loading, adjust only the two small screws (Fig.5.1.1b).

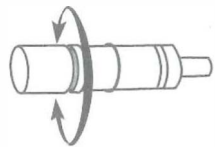

Fig.5.1.1a

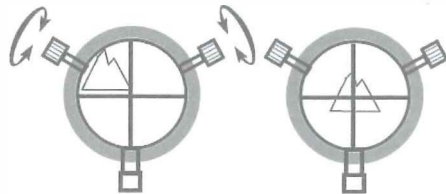

Fig.5.1.1b

### 2. Aligning and using the red dot finder

- The Red Dot Finder is a zero magnification pointing tool that uses a coated glass window to superimpose the image of a small red dot onto the night sky. The Red Dot Finder is equipped with a variable brightness control, azimuth adjustment control, and altitude adjustment control (Fig.5.1.2a). The Red Dot Finder is powered by a 3-volt lithium battery located underneath at the front. To use the Finder, simply look through the sight tube and move your telescope until the red dot merges with the object. Make sure to keep both eyes open when sighting.
- Like all finderscopes, the Red Dot Finder must be properly aligned with the main telescope before use. This is a simple process using the azimuth and altitude control knobs.

- Open the battery cover by pulling it down (you can gently pry at the 2 small slots) and remove the plastic shipping cover over the battery (Fig.5.1.2b).
- Turn on the Red Dot Finder by rotating the variable brightness control clockwise until you hear a "click". Continue rotating the control knob to increase the brightness level.
- Insert a low power eyepiece into the telescope's focuser. Locate a bright object and position the telescope so that the object is in the center of the field of view.
- With both eyes open, look through the sight tube at the object. If the red dot overlaps the object, your Red Dot Finder is perfectly aligned. If not, turn its azimuth and altitude adjustment controls until the red dot is merged with the object.

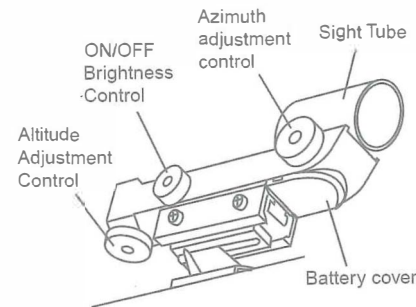

Fig.5.1.2a

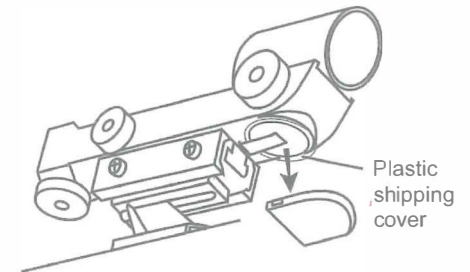

Fig.5.1.2b

## 5.2 Focusing the telescope

- Slowly turn the focus knobs under the focuser, one way or the other, until the image in the eyepiece is sharp (Fig.5.2a). The image usually has to be finely refocused over time, due to small variations caused by temperature changes, flexures, etc. This often happens with short focal ratio telescopes, particularly when they haven't yet reached outside temperature. Refocusing is almost always necessary when you change an eyepiece.

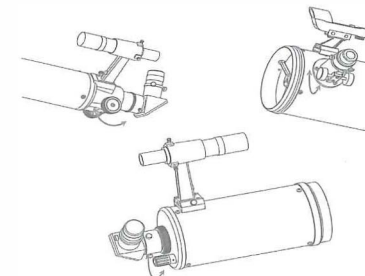

Fig.5.2a

### 5.3 Choosing the appropriate eyepiece

- The magnification produced by a telescope is determined by the focal length of the eyepiece that is used with it. To determine a magnification for your telescope, divide its focal length by the focal length of the eyepieces you are going to use. For example, a 10mm focal length eyepiece will give 80X magnification with an 800mm focal length telescope.
- When you are looking at astronomical objects, you are looking through a column of air that reaches to the edge of space and that column seldom stays still. Similarly, when viewing over land you are often looking through heat waves radiating from the ground, house, buildings, etc. Your telescope may be able to give very high magnification but what you end up magnifying is all the turbulence between the telescope and the subject. A good rule of thumb is that the usable magnification of a telescope is about 2X per mm of aperture under good conditions.
- Too much magnification and too small a field of view can make it very hard to find things. It is usually best to start at a lower magnification with its wider field of view and then increase the magnification when you have found what you are looking for. First find the moon then look at the shadows in the craters!

## PART VI: Observing the sky

### 6.1 Sky Conditions

- Sky conditions are usually defined by two atmospheric characteristics, seeing, or the steadiness of the air, and transparency, light scattering due to the amount of water vapour and particulate material in the air. When you observe the Moon and the planets, and they appear as though water is running over them, you probably have bad "seeing" because you are observing through turbulent air. In conditions of good "seeing", the stars appear steady, without twinkling, when you look at them with unassisted eyes (without a telescope). Ideal "transparency" is when the sky is inky black and the air is unpolluted.

### 6.2 Selecting an Observing Site

- Travel to the best site that is reasonably accessible. It should be away from city lights, and upwind from any source of air pollution. Always choose as high an elevation as possible; this will get you above some of the lights and pollution and will ensure that you aren't in any ground fog. Sometimes low fog banks help to block light pollution if you get above them. Try to have a dark, unobstructed view of the horizon, especially the southern horizon if you are in the Northern Hemisphere and vice versa. However, remember that the darkest sky is usually at the "Zenith", directly above your head. It is the shortest path through the atmosphere. Do not try to observe any object when the light path passes near any protrusion on the ground. Even extremely light winds can cause major air turbulence as they flow over the top of a building or wall. Observing through a window is not recommended because the window glass will distort images considerably. And an open window can be even worse, because warmer indoor air will escape out the window, causing turbulence which also affects images. Astronomy is an outdoor activity. The best conditions will have still air, and obviously, a clear view of the sky. It is not necessary that the sky be cloud-free. Often broken cloud conditions provide excellent seeing.

### 6.3 Choosing the Best Time to Observe

- Do not view immediately after sunset. After the sun goes down, the Earth is still cooling, causing air turbulence. As the night goes on, not only will seeing improve, but air pollution and ground lights will often diminish. Some of the best observing time is often in the early morning hours. Objects are best observed as they cross the meridian, which is an imaginary line that runs through the Zenith, due North-South. This is the point at which objects reach their highest points in the sky. Observing at this time reduces bad atmospheric effects. When observing near the horizon, you look through lots of atmosphere, complete with turbulence, dust particles and increased light pollution.

#### 6.4 Cooling the Telescope

- Telescopes require at least 10 to 30 minutes to cool down to outside air temperature. This may take longer if there is a big difference between the temperature of the telescope and the outside air. This minimizes heatwave distortion inside telescope tube (tube currents). Allow a longer cooling time for larger optics.

#### 6.5 Adapting Your Eyes

- Do not expose your eyes to anything except red light for 30 minutes prior to observing. This allows your pupils to expand to their maximum diameter and build up the levels of optical pigments, which are rapidly lost if exposed to bright light. It is important to observe with both eyes open. This avoids fatigue at the eyepiece. If you find this too distracting, cover the non-used eye with your hand or an eye patch. Use averted vision on faint objects: The center of your eye is the least sensitive to low light levels. When viewing a faint object, don't look directly at it. Instead, look slightly to the side, and the object will appear brighter.

## PART VII: Proper Care for Your Telescope

#### 7.1 Cleaning Your Telescope

- Replace the dust cap over end of telescope whenever not in use. This prevents dust from settling on mirror or lens surface. Do not clean mirror or lens unless you are familiar with optical surfaces. Clean eyepieces with special lens paper only. Eyepieces should be handled with care, avoid touching optical surfaces.

## APPENDIX : SPECIFICATIONS

### Dimensions:

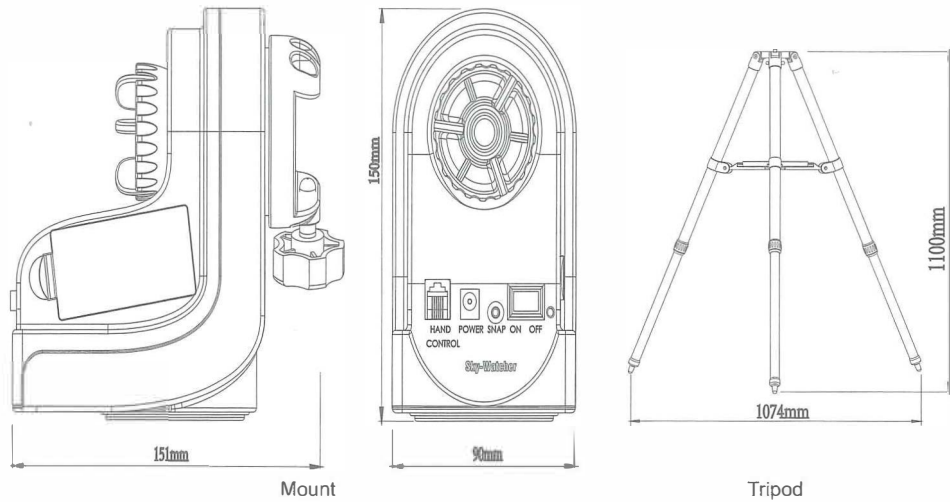

### Specifications:

Product Name	AZ-GTe Mount
Mount Type	Altitude-azimuth Mount
Payload	5 kg
Mount's Weight	1.3 kg
Tripod + Extension Pier Weight	1.9 kg + 0.5kg
Power Requirement	DC7.5~14V, 0.75A
Motor	DC Servo Motor
Gear Ratio	6480
Resolution	2073600 Counts/Rev., 0.625 arc-second
Resolution of Aux. R.A./Dec. Axis Encoders	1068 Counts/Rev., approx. 20 arc-minutes
Default Wi-Fi Access Point SSID	SynScan xxxx
Access Point IP Address	192.168.4.1
Network Protocol	UDP, Port 11880

**Note:** The above specifications may be changed without prior notice.