

# MANUFACTURERS MOTOR VEHICLE SPECIFICATIONS

METRIC( U.S. Customary)

Passenger Car

# 1986

Manufacturer FORD MOTOR COMPANY	Car Line MUSTANG SVO	
Mailing Address P. O. BOX 2053 DEARBORN, MICHIGAN 48121	Issued SEPTEMBER, 1985	Revised

Questions concerning these specifications should be directed to the manufacturer whose address is shown above.

The information contained herein is prepared, distributed by, and is solely the responsibility of the automobile manufacturing company to whose products it relates. This specification form was developed by the automobile manufacturing companies under the auspices of the Motor Vehicle Manufacturers Association of the United States, Inc.

The General Specifications herein are those in effect at date of compilation and are subject to change without notice by the manufacturer.

Blank Forms Provided by Technical Affairs Division



Motor Vehicle Manufacturers Association  
of the United States, Inc.

# MVMA Specifications Form Passenger Car

Car Line SVO  
 Model Year 1986 Issued 9/85 Revised (●) \_\_\_\_\_

METRIC (U.S. Customary)

## Car Models

Model Description & Drive (FWD/RWD)	Introduction Date	Make, Car Line, Series, Body Type (Mfg's Model Code)	No. of Designated Seating Positions (Front/Rear)	Max. Trunk/Cargo Load—Kilograms (Pounds)
% <u>SVO-MODEL</u>  2-Door Hatchback	10-03-85	61B (B8G)	2/2	45.4 (100)
% Rear Wheel Drive (RWD)				

# MVMA Specifications Form Passenger Car

Car Line SVO  
 Model Year 1986 Issued 9/85 Revised (•) \_\_\_\_\_

**METRIC (U.S. Customary)**

**Power Teams** (Indicate whether standard or optional)

SAE J1349 Net bhp (brake horsepower) and net torque corrected to 77°F/25° C and 29.61 in. Hg/100 kPa atmospheric pressure.

SERIES AVAILABILITY	ENGINE					E x h a u s t S/D	TRANSMISSION TRANSAXLE	AXLE RATIO (std. first)
	Displ. Liters (in <sup>3</sup> )	Carb. (Barrels, Fl, etc.)	Compr. Ratio	SAE Net at RPM				
				kW (bhp)	Torque N·m (lb. ft.)			
			<u>50 STATES/CANADA/ALTITUDE</u>					
2-Door Hatchback	2.3 Turbo (140)	EFI	8.0	149 (200) 5000	325 (240) 3200	D	M50D	3.73-T
M50D - 5-Speed Manual Overdrive T - Traction-Lok Axle								

# MVMA Specifications Form Passenger Car

Car Line SVO  
 Model Year 1986 Issued 9/85 Revised (e) 11/85

**METRIC (U.S. Customary)**

Engine Description/Carb.  
Engine Code

2.3L

## ENGINE - GENERAL

Type & description (inline, V, angle, flat, location, front, mid, rear, transverse, longitudinal, sohc, dohc, ohv, hemi, wedge, pre-camber, etc.)	Inline, Front, Longitudinal (SOHC) Single Overhead Camshaft Modified Wedge Combustion Chamber	
Manufacturer	Ford Motor Company	
No. of cylinders	Four	
Bore	96.04 (3.78)	
Stroke	79.40 (3.12)	
Bore spacing (C/L to C/L)	105.99 (4.17)	
Cylinder block material & mass kg (lbs.)	Cast Iron & 39.5 (87)	
Cylinder block deck height	212.55 (8.36)	
Deck clearance (minimum) (above or below block)	0.178 (0.007) Above	
Cylinder head material & mass kg (lbs.)	Cast Iron 24.5 (54.0)	
Cylinder head volume (cm <sup>3</sup> )	61.3	
Head gasket thickness (compressed)	1.09 (0.043)	
Minimum combustion chamber total volume (cm <sup>3</sup> )	74.6	
Cyl. no. system (front to rear)*	L. Bank	--
	R. Bank	--
Firing order	1, 3, 4, 2	
Intake manifold material & mass [kg (weight, lbs.)]	Aluminum 5.50 (12.1)	
Exhaust manifold material & mass [kg (weight, lbs.)]	Cast Iron 5.38 (11.85)	
Recommended fuel (leaded, unleaded, diesel)	Unleaded	
Fuel antiknock index (R + M) 2	87 Minimum Octane	
Total dressed engine mass (wt) dry**	195 (429.6)	

## Engine - Pistons

Material & mass, g (weight, oz.) - piston only	Forged Aluminum Alloy 480 (16.9)
--	-------------------------------------

## Engine - Camshaft

Location	Cylinder Head	
Material & mass kg (weight, lbs.)	ESE-M2A-117-B Hardenable Cast Iron 2.93 (6.45)	
Drive type	Chain / belt	Belt
	Width / pitch	21.8 - 22.8 (0.86 - 0.90)/9.52 (0.37)

\* Rear of engine - drive takeoff. View from drive takeoff end to determine left & right side of engine.

\*\* Dressed engine mass (weight) includes the following: Front end dress, all engine mounted components and flywheel; no oil, coolant or starter.

# MVMA Specifications Form Passenger Car

METRIC (U.S. Customary)

Car Line SVO  
 Model Year 1986 Issued 9/85 Revised (●) \_\_\_\_\_

Engine Description/Carb.  
 Engine Code

2.3L

### Engine – Valve System

Hydraulic lifters (std., opt., NA)	Standard	
Valves	Number intake / exhaust	4/4
	Head O.D. intake / exhaust	44.38

### Engine – Connecting Rods

Material & mass [kg., (weight, lbs.)]	Forged Steel (SAE-1041-H or SAE-1541-H) 0.63-0.64(1.38-1.41)
---------------------------------------	--

### Engine – Crankshaft

Material & mass [kg., (weight, lbs.)]	Nodular Cast Iron Alloy 15.48 (34.13)	
End thrust taken by bearing (no.)	#3	
Number of main bearings	5	
Seal (material, one, two piece design, etc.)	Front	Poly Acrylic, One Piece (a)
	Rear	Silicon, One Piece (a)

### Engine – Lubrication System

Normal oil pressure [kPa (psi) at engine rpm]	345 (50) @ 2000
Type oil intake (floating, stationary)	Stationary
Oil filter system (full flow, part, other)	Full Flow
Capacity of c/case, less filter-refill-L (qt.)	4.3 (4.5) 4.75 (5.0) with Filter

### Engine – Diesel Information (NOT OFFERED)

Diesel engine manufacturer		
Glow plug, current drain at 0°F		
Injector nozzle	Type	
	Opening pressure [kPa (psi)]	
Pre-chamber design		
Fuel in-jection pump	Manufacturer	
	Type	
Fuel injection pump drive (belt, chain, gear)		
Supplementary vacuum source (type)		
Fuel heater (yes/no)		
Water separator, description (std., opt.)		
Turbo manufacturer		
Oil cooler-type (oil to engine coolant; oil to ambient air)		
Oil filter		

### Engine – Intake System

Turbo charger - manufacturer	Garrett-AID
Super charger - manufacturer	N/A
Charge cooler	Yes

(a) Vitron Seal, One Piece to be available as running change after Job #1

# MVMA Specifications Form Passenger Car

Car Line SVO  
 Model Year 1986 Issued 9/85 Revised (●) \_\_\_\_\_

**METRIC (U.S. Customary)**

Engine Description/Carb.  
Engine Code

2.3L

## Engine - Cooling System

Coolant recovery system (std., opt., n.a.)	Standard	
Coolant fill location (rad., bottle)	Radiator Fill; Overflow Bottle Add	
Radiator cap relief valve pressure [kPa (psi)]	82 - 110 (12-16) Non-A/C, 96-124 (14-18) w/A/C	
Circulation thermostat	Type (choke, bypass)	By-Pass
	Starts to open at °C (°F)	87 (188-195)
Water pump	Type (centrifugal, other)	Centrifugal-Vane
	GPM @1000 pump rpm	13.1
	Number of pumps	One
	Drive (V-belt, other)	V-Belt
	Bearing type	Double Row, Sealed, Ball & Roller (3/4")
	Impeller material	Steel
	Housing material	Cast Iron
By-pass recirculation [type (inter., ext.)]	Internal	
Cooling system capacity	With heater - L(qt.)	8.4 (8.9)
	With air cond. - L(qt.)	8.4 (8.9)
	Opt. equipment [specify - L(qt.)]	None
Water jackets full length of cyl. (yes, no)	Yes	
Water all around cylinder (yes, no)	Yes	
Water jackets open at head face (yes, no)	Yes	
Radiator core	Std., A/C, HD	Standard and A/C use same radiator core
	Type (cross-flow, etc.)	Cross-Flow
	Construction (fin & tube mechanical, braze, etc.)	Tube and Slit Fin
	Material, mass [kg (wt. lbs.)]	Brass/Copper, 5.9 (12.9)
	Width	623.3 (24.5)
	Height	453.1 (17.8)
	Thickness	35.6 (1.1)
Fins per inch	11	
Radiator end tank material	Brass	
	Std., elec., opt.	Electrodrive Std.
Fan	Number of blades & type (flex, solid, material)	Four Blade, Solid Plastic
	Diameter & projected width	406 (16.0) 35 (1.4)
	Ratio (fan to crankshaft rev.)	N/A
	Fan cutout type	N/A
	Drive type (direct, remote)	Remote
	RPM at idle (elec.)	1500
	Motor rating (wattage) (elec.)	180 Watt
	Motor switch (type & location) (elec.)	Top Water Sensing - Elect.
	Switch point (temp., pressure) (elec.)	225°
Fan shroud (material)	Polypropylene Ring w/Wire Legs	

# MVMA Specifications Form Passenger Car

Car Line SVO  
 Model Year 1986 Issued 9/85 Revised (●) \_\_\_\_\_

**METRIC (U.S. Customary)**

Engine Description/Carb.  
Engine Code

2.3L

**Engine — Fuel System** (See supplemental page for details of Fuel Injection, Supercharger, Turbocharger, etc. if used)

Induction type: carburetor, fuel injection system, etc.		Electronic Fuel Injection	
Carburetor	Mfgr.	N/A	
	Choke (type)	N/A	
	Idle spd.-rpm (spec. neutral or drive and propane if used)	Manual	N/A
		Automatic	N/A
Idle A/F mix.		N/A	
Fuel injection	Point of injection (no.)	Port, Four	
	Constant, pulse, flow	Simultaneous Double Fire, Pulse Flow	
	Control (electronic, mech.)	Electronic	
	System pressure [kPa (psi)]	269 (39.0)	
Intake manifold heat control (exhaust or water thermostatic or fixed)		N/A	
Air cleaner type	Standard	Remote Replaceable Paper Element	
	Optional	N/A	
Fuel pump	Type (elec. or mech.)	Electric (1)	
	Location (eng., tank)	High Pressure In-Tank	
	Pressure range [kPa (psi)]	38-45 (5.5 - 6.5)	

**Fuel Tank**

Capacity [refill L (gallons)]		58.3 (15.4)
Location (describe)		Behind Rear Axle
Attachment		Two Straps with Pin and Loop at Rear, Bolt at Front
Material & Mass [kg (weight lbs)]		Steel (Terne Plate)
Filler pipe	Location & material	Right Rear Quarter Panel, Steel
	Connection to tank	Rubber Seal
Fuel line (material)		Steel and Nylon
Fuel hose (material)		N/A
Return line (material)		Steel and Nylon
Vapor line (material)		Steel and Nylon
Extended range tank	Opt., n.a.	N/A
	Capacity [L (gallons)]	--
	Location & material	--
	Attachment	--
Auxiliary tank	Opt., n.a.	--
	Capacity [L (gallons)]	--
	Location & material	--
	Attachment	--
	Selector switch or valve	--
Separate fill		--

# MVMA Specifications Form Passenger Car

Car Line SVO  
 Model Year 1986 Issued 9/85 Revised (●) \_\_\_\_\_

**METRIC (U.S. Customary)**

Engine Description/Carb.  
Engine Code

2.3L

## Vehicle Emission Control

Exhaust Emission Control	Type (air injection, engine modifications, other)		Electronic Fuel and Spark Control Plus Exhaust Gas Recirculation	
	Air Injection	Pump or pulse	N/A	
		Driven by	N/A	
		Air distribution (head, manifold, etc.)	N/A	
		Point of entry	N/A	
	Exhaust Gas Recirculation	Type (controlled flow, open orifice, other)	Controller Flow Tapered Stem	
		Exhaust source	Exhaust Manifold	
		Point of exhaust injection (spacer, carburetor, manifold, other)	Intake Manifold	
	Catalytic Converter	Type	TWC + TWC Dual Brick Transverse	
		Number of	One	
		Location(s)	Underbody	
		Volume [L (in <sup>3</sup> )]	1.1 (66) + 1.6 (66)	
	Crankcase Emission Control	Substrate type		Coated Ceramic Monolith
		Type (ventilates to atmosphere, induction system, other)		Closed Induction System
Energy source (manifold vacuum, carburetor, other)		Manifold Vacuum		
Discharges (to intake manifold, other)		Intake Manifold		
Evaporative Emission Control	Air inlet (breather cap, other)		Compressor Inlet Adaptor	
	Vapor vented to (crankcase, canister, other)	Fuel tank	Carbon Canister	
		Carburetor	N/A	
Vapor storage provision		Carbon Canister		
Electronic system	Closed loop (yes/no)		Yes	
	Open loop (yes/no)		Yes	

## Engine - Exhaust System

Type (single, single with cross-over, dual, other)		Dual with Reverse "Y" behind Catalyst
Muffler no. & type (reverse flow, straight thru, separate resonator) Material & Mass [kg (weight lbs)]		Two, Reverse Flow
Resonator no. & type		None
Exhaust pipe	Branch o.d., wall thickness	
	Main o.d., wall thickness	63.5 x 1.75 (2.50 x .069)
	Material & Mass [kg (weight lbs)]	409 Stainless Steel
Inter-mediate pipe	o.d. & wall thickness	63.5 x 1.75 (2.50 x .069)
	Material & Mass [kg (weight lbs)]	Aluminized Low Carbon Steel
Tail pipe	o.d. & wall thickness	63.5 x 1.75 (2.50 x .069)
	Material & Mass [kg (weight lbs)]	Aluminized Low Carbon Steel



# MVMA Specifications Form Passenger Car

Car Line SVO  
 Model Year 1986 Issued 9/85 Revised (●) \_\_\_\_\_

**METRIC (U.S. Customary)**

Engine Description/Carb.  
 Engine Code

2.3L

## Transmissions/Transaxle

Manual 3-speed (std., opt., n.a.) (mfr.)	N/A
Manual 4-speed (std., opt., n.a.) (mfr.)	N/A
Manual 5-speed (std., opt., n.a.) (mfr.)	Standard, Borg Warner
Manual overdrive (std., opt., n.a.) (mfr.)	N/A
Automatic (std., opt., n.a.) (mfr.)	N/A
Automatic overdrive (std., opt., n.a.) (mfr.)	N/A

## Manual Transmission/Transaxle

Number of forward speeds	Five		
Transmission ratios	In first	3.50:1	
	In second	2.14:1	
	In third	1.36:1	
	In fourth	1.00:1	
	In fifth	.78:1	
	In overdrive	5th Gear	
	In reverse	3.39:1	
Synchronous meshing (specify gears)	1st, 2nd, 3rd, 4th, 5th		
Shift lever location	Floor		
Lubricant	Capacity [L (pt.)]	2.6 (5.6)	
	Type recommended	Dexron II	
	SAE viscosity number	Summer	ATF
		Winter	ATF
Extreme cold		ATF	

## Clutch (Manual Transmission)

Make, type, engagement (describe) - (hydraulic, cable, rod)	Single Disc, Dry Plate, Cable with Self Adjustment	
Assist (yes, no percent)	No	
Type pressure plate springs	Belleville Spring	
Total spring load [N (lb.)]	6886 (1548)	
No. of clutch driven discs	One	
Clutch facing	Material	Non-Asbestos, Organic Valqua NK43
	Manufacturer	Daikin
	Part number	E5ZX-7550-AA
	Rivets/plate	16
	Rivet size	4.1 x 4.9 (.161 x .193)
	Outside & inside dia.	226 x 149.2 (8.90 x 5.87)
	Total eff. area [cm <sup>2</sup> (in. <sup>2</sup> )]	452.6 (70.2)
	Thickness	3.8 (.150)/3.2 (.126) Pressure Plate/Flywheel
Engagement cushion method	One Piece Riveted Hybrid	
Release bearing	Type & method of lubrication	Self Centering, Angular Contact, Constant Running, Prepacked
Torsional damping	Method, springs, friction material	Steel Coil Springs/Dry Friction

# MVMA Specifications Form Passenger Car

Car Line SVO  
 Model Year 1986 Issued 9/85 Revised (●) \_\_\_\_\_

**METRIC (U.S. Customary)**

Engine Description/Carb.  
 Engine Code

2.3L

**Automatic Transmission/Transaxle** (NOT OFFERED)

Trade name		
Type and special features (describe)		
Selector	Location	
	Ltr./No. designation	
Gear ratios	R	
	D	
	L <sub>3</sub>	
	L <sub>2</sub>	
	L <sub>1</sub>	
Max. upshift speed - drive range [km/h (mph)]		
Max. kickdown speed - drive range [km/h (mph)]		
Min. overdrive speed [km/h (mph)]		
Torque converter	Number of elements	
	Max. ratio at stall	
	Type of cooling (air, liquid)	
	Nominal diameter	
Lubricant	Capacity [refill L (pt.)]	
	Type Recommended	
Oil cooler (std., opt., NA, internal, external, air, liquid)		

**Axle or Front Wheel Drive Unit**

Type (front, rear)		Rear	
Description		Semi-floating type with cast center and overhung pinion	
Limited slip differential (type)		Friction Plate	
Drive pinion offset		25.4 (1.0)	
Drive pinion (type)		Hypoid	
No. of differential pinions		Two	
Pinion / differential adjustment (shim, other)		Shim	
Pinion / differential bearing adjustment (shim, other)		Collapsible spacer	
Driving wheel bearing (type)		Straight roller	
Lubricant	Capacity [L (pt.)]	1.5 (3.25) Conventional and Traction-Lok	
	Type recommended	ESP-M2C154-A	
	SAE viscosity number	Summer	SAE 85W90
		Winter	SAE 85W90
	Extreme cold	SAE 85W90	

**Axle or Transaxle Ratio and Tooth Combinations** (See 'Power Teams' for axle ratio usage.)

Axle ratio (or overall top gear ratio)		3.73:1
No. of teeth	Pinion	11
	Ring gear or gear	41
Ring gear o.d.		190.5 (7.5)
Transaxle	Transfer gear ratio	N/A
	Final drive ratio	N/A

# MVMA Specifications Form Passenger Car

Car Line SVO  
 Model Year 1986 Issued 9/85 Revised (●) \_\_\_\_\_

**METRIC (U.S. Customary)**

Engine Description/Carb.  
 Engine Code

2.3L

## Propeller Shaft – Rear Wheel Drive

Type (straight tube, tube-in-tube, internal-external damper, etc.)		Internal Tuned Damper
Outer diam. x length* x wall thickness	Manual 3-speed trans.	N/A
	Manual 4-speed trans.	N/A
	Manual 5-speed trans.	76.2 x 1157.7 x 1.65 (3.00 x 45.50 x .065)
	Overdrive	N/A
	Automatic transmission	N/A
Inter-mediate bearing	Type (plain, anti-friction)	N/A
	Lubrication (fitting, prepack)	N/A
Shp yoke	Type	Tuned Damper
	Number of teeth	28
	Spline o.d.	30,988 (1.22) Max.
Universal joints	Make and mfg. no.	Front Ford 1310
		Rear Ford 1310
	Number used	Two
	Type (ball and trunnion, cross)	Cross
	Rear attach (u-bolt, clamp, etc.)	12 (0.47) Bolts
	Bearing	Type (plain, anti-friction)
Lubrication (fitting, prepack)		Prepack
Drive taken through (torque tube, arms or springs)		Control Arms
Torque taken through (torque tube, arms or springs)		Control Arms

\* Centerline to centerline of universal joints, or to centerline of rear attachment.

# MVMA Specifications Form Passenger Car

Car Line SVO  
Model Year 1986 Issued 9/85 Revised (●) \_\_\_\_\_

## METRIC (U.S. Customary)

Body Type And/Or  
Engine Displacement

2-DOOR HATCHBACK

### Suspension – General

Car leveling	Std./opt./n.a.	N/A
	Type (air, hyd., etc.)	N/A
	Manual/auto. controlled	N/A
Provision for brake dip control		Front Springs Mounted on Lower Control Arm
Provision for accel. squat control		Unequal Length Upper/Lower Control Arms (Rear Suspension)
Provisions for car jacking		Side of Car - Outside Rocker Panel Flanges, Front & Rear
Shock absorber (front & rear)	Type	Direct Acting, Adjustable Nitrogen-Gas Press.Hyd.Frt.Struts & Rear Vert. Shocks, Freon Bag Hydraulic Horizontal Axle Dmprs
	Make	Koni <sup>®</sup> Adjustable
	Piston diameter	Front (34.8 (1.37)); Rear 25.4 (1.00); Damper 25.4 (1.00)
	Rod diameter	Front 22 (0.87); Rear 12.5 (0.50); Damper 9.75 (0.38)

### Suspension – Front

Type and description		Hybrid MacPherson Strut w/Springs Mounted On Lower Control Arms
Drive and torque taken through		Rear Springs
Travel	Full jounce	91.00 (3.58)
	Full rebound	86.86 (3.42)
Spring	Type (coil, leaf, other) & material	Coil, SAE 5160 Steel
	Insulators (type & material)	Upper - Ring, Lower - Sleeve & Rubber
	Size (coil design height & i.d., bar length x dia.)	Size - 254 x 89.0 (10.0 x 3.50) Coil 2974 (117.1) Bar Length; 16.1 (0.63) Bar Diameter
	Spring rate [N/mm (lb./in.)]	72.0 (410)
	Rate at wheel [N/mm (lb./in.)]	25.6 (146)
Stabilizer	Type (link, linkless, frameless)	Link, Rubber Side Rail Insulator
	Material & bar diameter	30.5 (1.20)

### Suspension – Rear

Type and description		Quadra Shock Four Bar Link Coil Spring on Lower Arm
Drive and torque taken through		Upper & Lower Control Arms
Travel	Full jounce	82.60 (3.25)
	Full rebound	117.60 (4.63)
Spring	Type (coil, leaf, other) & material	Coil, SAE 5160-H Steel
	Size (length x width, coil design height & i.d., bar length & dia.)	Size - 102 x 220.0 (8.69 x 4.02) 2678 (105.4) Bar Length; 13.2 (0.52) Bar Diameter
	Spring rate [N/mm (lb./in.)]	35 (200)
	Rate at wheel [N/mm (lb./in.)]	17.6 (100.5)
	Insulators (type & material)	Rubber
	If leaf	No. of leaves
Shackle (comp. or tens.)		N/A
Stabilizer	Type (link, linkless, frameless)	Linkless
	Material & bar diameter	SAE 1090 Steel 17.0 (0.67)
Track bar (type)		None

# MVMA Specifications Form Passenger Car

Car Line SVO  
Model Year 1986 Issued 9/85 Revised (●) \_\_\_\_\_

**METRIC (U.S. Customary)**

Body Type And/Or  
Engine Displacement

2-DOOR HATCHBACK

## Brakes - Service

Description		Four Wheel Hydraulic Actuated System			
Brake type (std., opt., n.a.)	Front (disc or drum)	Disc			
	Rear (disc or drum)	Disc			
Self-adjusting (std., opt., n.a.)		Standard			
Special valving	Type (proportion, delay, metering, other)	Pressure Differential and Proportioning			
Power brake (std., opt., n.a.)		Standard			
Booster type (remote, integral, vac., hyd., etc.)		152.4 (6.0) Tandem Diaphragm - Integral - Vacuum			
Vacuum source (inline, pump, etc.)		N/A			
Vacuum reservoir (volume in. <sup>3</sup> )		N/A			
Vacuum pump-type (elec. gear driven, belt driven, if other so state)		N/A			
Anti-skid device type (std., opt., n.a.) (F/R)		N/A			
Effective area [cm <sup>2</sup> (in. <sup>2</sup> )]* (F/R)		246.3 (38.2)/179 (27.7)			
Gross lining area [cm <sup>2</sup> (in. <sup>2</sup> )]**(F/R)		257.7 (39.9)/226.4 (35.1)			
Swept area [cm <sup>2</sup> (in. <sup>2</sup> )]**(F/R)		1429.5 (221.6)/1356.8 (210.4)			
Rotor	Outerworking diameter	F/R	277.2 (10.9)/287 (11.3)		
	Inner working diameter	F/R	179.5 (7.06)/193 (7.6)		
	Thickness	F/R	26.2 (1.03)/24 (.94)		
	Material & type (vented/solid)	F/R	Cast Iron Vented/Cast Iron & Composite Steel Vented		
Drum	Diameter & width	F/R	N/A		
	Type and material	F/R	N/A		
Wheel cylinder bore		73 (2.87) - Front; 54 (2.13) - Rear			
Master cylinder	Bore/stroke	F/R	28 (1.10)/35.8 (1.41)		
Pedal arc ratio		3.5:1			
Line pressure at 445 N(100 lb.) pedal load [kPa (psi)]		5930 (1860)			
Lining clearance		F/R	.13 (.005)/.25 (.010)		
Brake lining	Front wheel	Bonded or riveted (rivets/seg.)		Riveted 6/Seg	
		Rivet size		4.87 (.190)	
		Manufacturer		Thiokol	
		Lining code*****		TP1471-EE	
		Material		Semi-Metallic	
		****	Primary or out-board	162.1x43.39x8.1 (6.38x1.71x0.32)	
		Size	Secondary or in-board	136.9x44.9x9.3 (5.39x1.77x0.37)	
	Shoe thickness (no lining)		5.3 (.203)		
	Rear wheel	Bonded or riveted (rivets/seg.)		Riveted	
		Manufacturer		Thiokol	
		Lining Code*****		TP1471-EE	
		Material		Semi-Metallic	
		****	Primary or out-board	156.5x40.5x10 (6.16x1.59x0.39)	
		Size	Secondary or in-board	156.5x40.5x10 (6.16x1.59x0.39)	
Shoe thickness (no lining)		5.0 (.197)			

\*Excludes rivet holes, grooves, chamfers, etc.

\*\*Includes rivet holes, grooves, chamfers, etc.

\*\*\*Total swept area for four brakes. (Drum brake: Widest lining contact width for each brake x its contact circumference.)  
(Disc brake: Square of Outer Working Dia. minus Square of inner Working Dia. multiplied by Pi/2 for each brake.)

\*\*\*\*Size for drum brakes includes length x width x thickness.

\*\*\*\*\*Manufacturer I.D., catalog or formulation designation and coefficient of friction classification.

# MVMA Specifications Form Passenger Car

Car Line SVO  
 Model Year 1986 Issued 9/85 Revised (#) \_\_\_\_\_

**METRIC (U.S. Customary)**

Body Type And/Or  
Engine Displacement

2-DOOR HATCHBACK

## Tires And Wheels (Standard)

Tires	Size (load range, ply)		P225/50VR16
	Type (bias, radial, etc.)		Steel Belted Radial
	Inflation pressure (cold) for recommended max. vehicle load	Front [kPa (psi)]	193 (28)
		Rear [kPa (psi)]	193 (28)
Rev./mile—at 70 km/h (45 mph)		1385.6 (861)	
Wheels	Type & material		Cast Aluminum
	Rim (size & flange type)		16 x 7
	Wheel offset		44.5 (1.75)
	Attachment	Type (bolt or stud)	Stud
		Circle diameter	4.50
Number & size		Five - 12.7 (.50) - 20 Thd	
Spare	Tire and wheel (same, if other describe)		Mini-Spare-T125/80D16,BSW,415kPa(60 PSI)with 16 x 4 JM Steel Stamped Wheel, Temporal Spare
	Storage position & location (describe)		Flat Position, Deep Well in Trunk

## Tires And Wheels (Optional)

(NOT OFFERED)

Size (load range, ply)	
Type (bias, radial, etc.)	
Wheel (type & material)	
Rim (size, flange type and offset)	
Size (load range, ply)	
Type (bias, radial, etc.)	
Wheel (type & material)	
Rim (size, flange type and offset)	
Size (load range, ply)	
Type (bias, radial, etc.)	
Wheel (type & material)	
Rim (size, flange type and offset)	
Size (load range, ply)	
Type (bias, radial, etc.)	
Wheel (type & material)	
Rim (size, flange type and offset)	
Size (load range, ply)	
Type (bias, radial, etc.)	
Wheel (type & material)	
Rim (size, flange type and offset)	
Spare tire and wheel	
(if configuration is different than road tire or wheel, describe optional spare tire and/or wheel location & storage position)	

## Brakes - Parking

Type of control	Pull Lever - Push Button Release	
Location of control	Tunnel Mounted	
Operates on	Rear Service Brakes	
If separate from service brakes	Type (internal or external)	--
	Drum diameter	--
	Lining size (length x width x thickness)	--

# MVMA Specifications Form Passenger Car

Car Line SVO  
 Model Year 1986 Issued 9/85 Revised (●) \_\_\_\_\_

**METRIC (U.S. Customary)**

**Body Type And/Or  
Engine Displacement**

2-DOOR HATCHBACK

## Steering

Manual (std., opt., n.a.)		N/A		
Power (std., opt., n.a.)		Standard		
Adjustable steering wheel (tilt, swing, other)	Type and description	Tilt - 5 Position		
	(Std., opt., n.a.)	Standard		
Wheel diameter (W9) SAE J1100	Manual	N/A		
	Power	368 (14.5)		
Turning diameter m (ft.)	Outside front	Wall to wall (l. & r.)		
		Curb to curb (l. & r.)	12.42 (40.75)	
	Inside rear	Wall to wall (l. & r.)		
		Curb to curb (l. & r.)		
Scrub Radius*				
Manual	Gear	Type	N/A	
		Make	---	
		Ratios		
		Gear	---	
	Overall	---		
No. wheel turns (stop to stop)		---		
Power	Type (coaxial, linkage, etc.)		Integral Rack and Pinion	
	Make		Gear - (Ford), Pump - (Ford); Fluid ESP-M2C138-CJ	
	Gear	Type	Rack and Pinion Constant Ratio	
		Ratios	*	6.44 <sup>0</sup> /mm
			Overall	15.01:1
	Pump (drive)		Belt Off Crankshaft Pulley	
No. wheel turns (stop to stop)		2.46		
Linkage	Type		Rack and Pinion (Rod & Ball Joint Direct Attach. to Gear)	
	Location (front or rear of wheels, other)		Front of Wheels	
	Tie rods (one or two)		Two (Integral with Gear)	
Steering axis	Inclination at camber (deg.)		15.7	
	Bearings (type)	Upper	Strut Mount	
		Lower	Ball Joint	
		Thrust	---	
Steering spindle & joint type		Forged Spindle, with Ball Joint		
Wheel spindle	Diameter	Inner bearing	34.8 (1.37)	
		Outer bearing	21.8 (0.86)	
	Thread (size)		13/16-20 UNEF 2A R.H. Thread	
	Bearing (type)		Tapered Roller	

\*The horizontal distance in the front elevation between wheel centerline and kingpin (ball joint) axis at ground.

\* Rack Speed

# MVMA Specifications Form Passenger Car

Car Line SVO  
Model Year 1986 Issued 9/85 Revised (●) \_\_\_\_\_

**METRIC (U.S. Customary)**

Body Type And/Or  
Engine Displacement

2-DOOR HATCHBACK

## Wheel Alignment

Front wheel at curb mass (wt.)	Service checking	Caster (deg.)	+1.0 <sup>0</sup> , Min +0.25 <sup>0</sup> /Max +1.75 <sup>0</sup> (a)
		Camber (deg.)	0.0 <sup>0</sup> , Min -0.75 <sup>0</sup> /Max +0.75 <sup>0</sup> (a)
		Toe-in [outside track-mm (in.)]	+4.8, Min+1.6/Max +7.9(+0.19, Min +0.06/Max +0.31)
	Service reset*	Caster	Factory Set and Cannot Be Adjusted
		Camber	0.0 <sup>0</sup> , Min -0.75 <sup>0</sup> /Max +0.75 <sup>0</sup> (a)
		Toe-in	+4.8, Min+1.6/Max+7.9(+0.19, Min +0.06/Max +0.31)
	Periodic M.V. inspection	Caster	+1.0 <sup>0</sup> , Min +0.25 <sup>0</sup> /Max +1.75 <sup>0</sup> (a)
		Camber	0.0 <sup>0</sup> , Min -0.75 <sup>0</sup> /Max +0.75 <sup>0</sup> (a)
		Toe-in	+4.8, Min+1.6/Max+7.9(+0.19, Min+0.06/Max+0.31)
Rear wheel at curb mass (wt.)	Service checking	Camber (deg.)	N.A.
		Toe-in [outside track-mm (in.)]	N.A.
	Service reset*	Camber	N.A.
		Toe-in	N.A.
	Periodic M.V. inspection	Camber	N.A.
		Toe-in	N.A.

\* Indicates pre-set, adjustable, trend set or other.

## Electrical – Instruments and Equipment

Speed-ometer	Type	Pointer
	Trip odometer (std., opt., n.a.)	Standard
EGR maintenance indicator		None
Charge indicator	Type	Light
	Warning device	Red Light
Temperature indicator	Type	Electric Gauge, 45 <sup>0</sup> Pointer
	Warning device	None
Oil pressure indicator	Type	Electric Gauge, 45 <sup>0</sup> Pointer
	Warning device	None
Fuel indicator	Type	Electric Gauge, 45 <sup>0</sup> Pointer
	Warning device	None
Wind-shield wiper	Type (standard)	Two-Speed Electric Column Mtd. Control, Interval Wipe
	Type (optional)	N.A.
	Blade length	406.4 (16.0)
	Swept area [cm <sup>2</sup> (in. <sup>2</sup> )]	4637 (718.7)
Wind-shield washer	Type (standard)	Electric Pump (Impeller Type)
	Type (optional)	None
	Fluid level indicator	None
Horn	Type	Air Electric
	Number used	Two Std. - One Hi-Pitch, One Lo-Pitch
Other	See Page 15A	Premium/Regular Unleaded Fuel Octane Selection Switch Turbo Boost Gauge, 45 <sup>0</sup> Pointer

(a) Max. Side to Side Difference Not to Exceed + 0.75<sup>0</sup>



**MVMA Specifications Form  
Passenger Car**

Car Line SVO  
Model Year 1986 Issued 9/85 Revised (#) \_\_\_\_\_

**METRIC (U.S. Customary)  
SUPPLEMENTAL PAGE**

---

Electrical - Instruments and Equipment: (Cont'd.)

- . Brake System Warning Light
- . Emergency Flashers
- . Directional Turn Signal Lights
- . Hi-Beam Indicator Light
- . Fasten Seat Belts Warning Light
- . Headlamps "ON" Warning Buzzer
- . Premium/Regular Unleaded Fuel Octane Selection Switch

# MVMA Specifications Form Passenger Car

Car Line SVO  
 Model Year 1986 Issued 9/85 Revised (●) \_\_\_\_\_

**METRIC (U.S. Customary)**

Engine Description/Carb.  
 Engine Code

2.3L

## Electrical – Supply System

Battery	Make	Motorcraft
	Model, std., (opt.)	Standard
	Voltage	12 Volt
	Amps at 0°F cold crank	450
	Minutes-reserve capacity	90
	Amp/hrs. - 20 hr. rate	54
	Location	Left Hand Front of Engine Compartment
Generator or alternator	Type and rating	E2BF-AA (65 Amp)
	Ratio (alt. crank/rev.)	2.42:1
	Optional (type & rating)	None
Regulator	Type	Electronic E4TF-10316-AA

## Electrical – Starting System

Start, motor	Current drain at 0°F	260-285 Amps
Motor drive	Engagement type	Positive
	Pinion engages from (front, rear)	Front

## Electrical – Ignition System

Type	Electronic (std., opt., n.a.)	Standard	
	Other (specify)	N/A	
Coil	Make	Motorcraft	
	Model	E3EF-12029-AA	
	Current	Engine stopped - A	6.5
		Engine idling - A	3.2
Spark plug	Make	Motorcraft	
	Model	AWSF-32C	
	Thread (mm)	14	
	Tightening torque (N-m (lb, ft))	7-14 (5-10)	
	Gap	.086 (.034)	
	Number per cylinder	One	
Distributor	Make	Motorcraft - EED	
	Model	TFI (Thick Film Ignition)	

## Electrical – Suppression

Locations & type	Capacitor in Alternator, Resistor Spark Plugs and Resistance Core Ignition Wire. Ground Cable - Engine to Dash Ground Cable, Hood Bond, RF Shielding Material. Ground Strap - Premium Sound Amp to Radio.
------------------	---

# MVMA Specifications Form Passenger Car

Car Line SVO  
 Model Year 1986 Issued 9/85 Revised (●) \_\_\_\_\_

**METRIC (U.S. Customary)**

**Body Type**

2-DOOR HATCHBACK

**Body**

Structure	Unitized All-Steel Welded Body, with One-Piece Side Stampings and Energy-Absorbing Front and Rear Structures
Bumper system front-rear	Impact-Resistant Polyurethane Fascia and Steel - HSLA 50 Understructure. Will Withstand 5 mph Impact from 15° Pendulum on Center-Line of Car Without Damage
Anti-corrosion treatment	<ul style="list-style-type: none"> <li>. Major Exterior &amp; Underbody Sheet Metal Components and Panels Pre-Coated (Galvanized) Steel</li> <li>. Body Cathodically Electrocoat Primed.</li> <li>. Urethane Chip Resistant Primer or Plastic Cladding on Lower Body Sides</li> </ul>

**Body - Miscellaneous Information**

Type of finish (lacquer, enamel, other)	Enamel (Acrylic)	
Hood	Hinge location (front, rear)	Rear
	Type (counterbalance, prop)	Prop
	Release control (internal, external)	Primary - Internal, Secondary - External
Trunk lid	Type (counterbalance, other)	N.A.
	Internal release control (elec., mech., n.a.)	N.A.
Hatch-back lid	Type (counterbalance, other)	Gas Cylinders
	Internal release control (elec., mech., n.a.)	Electric
Vent window control (crank, friction, pivot, power)	Front	None
	Rear	None
Seat cushion type (e.g., 60/40, bucket, bench, wire, foam etc.)	Front	Stamped Frame - Coil Spring & Flexolator - Foam Pad
	Rear	Integral Frame & Foam Pad Assembly
	3rd seat	None
Seat back type (e.g., 60/40, bucket, bench, wire, foam etc.)	Front	Stamped Frame - Foam Pad
	Rear	Frame Hard Board with Foam Pad Assembly
	3rd seat	None

**MVMA Specifications Form**  
**Passenger Car**  
**METRIC (U.S. Customary)**

Car Line SVO  
 Model Year 1986 Issued 9/85 Revised (•) \_\_\_\_\_

Body Type

2-DOOR HATCHBACK

**Restraint System**

Active restraint system	Standard/optional	Rear: Color Keyed Webbing Front: Color Keyed Webbing with Tension Eliminator
	Type and description	Continuous Loop - Front                      Lap Only - Rear
	Location	2 Seat Belts - Front                      2 - Rear
Passive seat belts	Standard/optional	N/A
	Power/manual	N/A
	2 or 3 point	N/A
	Knee bar/lap belt	N/A

**Frame**

Type and description (separate frame, unitized frame, partially-unitized frame)	Unitized Construction (Bolt on #2 Crossmember)
---	--

Glass	SAE Ref. No.	
Windshield glass exposed surface area [cm <sup>2</sup> (in. <sup>2</sup> )]	S1	8114 (1258)
Side glass exposed surface area [cm <sup>2</sup> (in. <sup>2</sup> )] - total 2-sides	S2	8101 (1256)
Backlight glass exposed surface area [cm <sup>2</sup> (in. <sup>2</sup> )]	S3	8569 (1328)
Total glass exposed surface area [cm <sup>2</sup> (in. <sup>2</sup> )]	S4	24784 (3841)
Windshield glass (type)		Laminated
Side glass (type)		Tempered
Backlight glass (type)		Tempered

**MVMA Specifications Form**  
**Passenger Car**  
**METRIC (U.S. Customary)**

Car Line SVO  
 Model Year 1986 Issued 9/85 Revised (●) \_\_\_\_\_

Body Type

2-DOOR HATCHBACK

**Convenience Equipment (standard, optional, n.a.)**

Air conditioning (manual, auto. temp control)	Optional, Manual Temperature Control	
Clock (digital, analog)	Standard, Digital	
Compass / thermometer	N.A.	
Console (floor, overhead)	Standard, Floor	
Defroster, elec. backlight	Standard	
Electronic	Diagnostic warning (integrated, individual)	N.A.
	Instrument cluster (list instruments)	N.A.
	Keyless entry	N.A.
	Trip/reminder (avg. spd., fuel)	N.A.
	Voice alert (list items)	N.A.
	Other	
Fuel door lock (remote, key, electric)	Standard, Electric Remote Control	
Lamps	Auto head on / off delay, dimming	N.A.
	Cornering	N.A.
	Courtesy (map. reading)	Standard
	Door lock, ignition	N.A.
	Engine compartment	Standard
	Fog	Standard
	Glove compartment	Standard
	Trunk	Standard
	Other	Standard, High Mount Stop Lamp
Mirrors	Day/night (auto. man.)	Standard, Manual
	L.H. (remote, power, heated)	Standard, Remote Control
	R. H. (convex, remote, power, heated)	Standard, Remote Control Convex
	Visor vanity (RH / LH, illuminated)	N.A.
Parking brake-auto release (warning light)	Standard, Pull Lever - Push Button Release	
Power equipment	Door locks / deck lid - specify	Standard
	Seat (2-4-6 way) heated (driver, pass, other) lumbar, hip, thigh support (power, manual) reclining (driver, pass) memory (1-2 preset, recline)	Sport Performance Bucket Seats, Multi-Adjustable, Articulated with Manual Lumbar Adjustment - Standard
	Side windows	Standard
	Vent windows	N.A.
	Rear window	N.A.
Radio systems	Antenna (location, whip, w/shield, power)	R.H. Front Fender Mounted, Whip
	AM, FM, stereo, tape, CB	Standard, Electronic AM/FM Stereo w/Cassette
	Speaker (number, location) Premium sound	Standard Dual Front and Rear
Roof open air/fixd (flip-up, sliding, "T")	N.A.	
Speed control device	N.A.	
Speed warning device (light, buzzer, etc.)	N.A.	
Tachometer (rpm)	Standard (0-8000)	
Theft protection-type	N.A.	

# MVMA Specifications Form

Car Line SVO  
 Model Year 1986 Issued 9/85 Revised (●) \_\_\_\_\_

## Passenger Car

### METRIC (U.S. Customary)

### Car and Body Dimensions See Key Sheets for definitions

All dimensions to ground are for comparative purposes only. Dimensions are to be shown for all base body models of each car line.  
 SAE Ref. no. refers to the definition published in SAE Recommended Practice J1100 "Motor Vehicle Dimensions," unless otherwise specified.

<b>Body Type</b>	<b>SAE Ref. No.</b>	2-DOOR HATCHBACK
------------------	---------------------	------------------

<b>Width</b>		
Tread (front)	W101	1468 (57.8)
Trear (rear)	W102	1481 (58.3)
Vehicle width	W103	1755 (69.1)
Body width at Sg RP (front)	W117	1735 (68.3)
Vehicle width (front doors open)	W120	3899 (153.5)
Vehicle width (rear doors open)	W121	--
Front fender overall width	W106	1717 (67.6)
Rear fender overall width	W107	1755 (69.1)
Tumble-home (deg.)	W122	25.2 <sup>0</sup>

<b>Length</b>		
Wheelbase	L101	2552 (100.5)
Vehicle length	L103	4592 (180.8)
Overhang (front)	L104	1041 (41.0)
Overhang (rear)	L105	998 (39.3)
Upper structure length	L123	2433 (95.8)
Rear wheel C/L "X" coordinate	L127	2195 (86.4)
Cowl point "X" coordinate	L125	208 (8.2)
Front end length at centerline	L126	1405 (55.3)
Rear end length at centerline	L129	384 (15.1)

<b>Height*</b>		
Passenger distribution (front/rear)	PD1,2,3	2/1
Trunk/cargo load		-0-
Vehicle height	H101	1323 (52.1)
Cowl point to ground	H114	958 (37.7)
Deck point to ground	H138	904 (35.6)
Rocker panel-front to ground	H112	193 (7.6)
Bottom of door closed-front to grd.	H133	257 (10.1)
Rocker panel-rear to ground	H111	170 (6.7)
Bottom of door closed-rear to grd.	H135	--
Windshield slope angle	H122	58 <sup>0</sup>
Backlight slope angle	H121	62 <sup>0</sup>

<b>Ground Clearance*</b>		
Front bumper to ground	H102	525 (20.7)
Rear bumper to ground	H104	336 (13.2)
Bumper to ground (front at curb mass (wt.))	H103	532 (20.9)
Bumper to ground (rear at curb mass (wt.))	H105	396 (15.6)
Angle of approach (degrees)	H106	18.6 <sup>0</sup>
Angle of departure (degrees)	H107	18.6 <sup>0</sup>
Ramp breakover angle (degrees)	H147	12.7 <sup>0</sup>
Axle differential to ground (front / rear)	H153	164 (6.5)
Min. running ground clearance	H156	122 (4.8)
Location of min. run. grd. clear.		Traction Bars

\* All vehicle height and ground clearances are made at the Manufacturer's Design Load Weight, unless otherwise specified.  
 Manufacturer's Design Load Weight is defined with indicated passenger distribution and trunk/cargo load.

# MVMA Specifications Form

Car Line SVO  
 Model Year 1986 Issued 9/85 Revised (●) \_\_\_\_\_

## Passenger Car

METRIC (U.S. Customary)

Car and Body Dimensions See Key Sheets for definitions

Body Type

<b>SAE Ref. No.</b>	2-DOOR HATCHBACK
---------------------	------------------

### Front Compartment

Sg RP front, "X" coordinate	L31	1034 (40.7)
Effective head room	H61	932 (36.7)
Max. eff. leg room (accelerator)	L34	1036 (40.8)
Sg RP to heel point	H30	231 (9.1)
Sg RP to heel point	L53	828 (32.6)
Back angle	L40	25°
Hip angle	L42	92°
Knee angle	L44	117.5°
Foot angle	L46	87°
Design H-point front travel	L17	178 (7.0)
Normal driving & riding seat track trvl.	L23	155 (6.1)
Shoulder room	W3	1420 (55.9)
Hip room	W5	1424 (56.1)
Upper body opening to ground	H50	1204 (47.4)
Steering wheel maximum diameter	W9	368 (14.5)
Steering wheel angle	H18	23.5°
Accel. heel pt. to steer. whl. cntr	L11	480 (18.9)
Accel. heel pt. to steer. whl. cntr	H17	599 (23.6)
Steering wheel to C/L of thigh	H13	84 (3.3)
Steering wheel torso clearance	L7	338 (13.3)
Headlining to roof panel (front)	H37	23 (0.9)
Undepressed floor covering thickness	H67	20 (0.8)

### Rear Compartment

Sg RP Point couple distance	L50	701 (27.6)
Effective head room	H63	904 (35.6)
Min. effective leg room	L51	780 (30.7)
Sg RP (second to heel)	H31	257 (10.1)
Knee clearance	L48	-31 (-1.2)
Compartment room	L3	602 (23.7)
Shoulder room	W4	1379 (54.3)
Hip room	W6	1196 (47.1)
Upper body opening to ground	H51	--
Back angle	L41	24°
Hip angle	L43	74.8°
Knee angle	L45	70°
Foot angle	L47	112.8°
Headlining to roof panel (second)	H38	N.A.
Depressed floor covering thickness	H73	20 (0.8)

### Luggage Compartment

Usable luggage capacity [L (cu. ft.)]	V1	N.A.
Liftover height	H195	757 (29.8)

### Interior Volumes (EPA Classification)

Vehicle class (subcompact, compact, etc.)	Subcompact
Interior volume index (cu. ft.)	94.2
Trunk/cargo index (cu. ft.)	12.2

# MVMA Specifications Form

Car Line SV0

Model Year 1986 Issued 9/85 Revised (●) \_\_\_\_\_

## Passenger Car

METRIC (U.S. Customary)

Car and Body Dimensions See Key Sheets for definitions

Body Type

<b>SAE Ref. No.</b>	2-DOOR HATCHBACK
---------------------	------------------

### Station Wagon – Third Seat (NOT APPLICABLE)

Sg RP couple distance	L85	
Shoulder room	W85	
Hip room	W86	
Effective leg room	L86	
Effective head room	H86	
Sg RP to heel point	H87	
Knee clearance	L87	
Seat facing direction	SD1	
Back angle	L88	
Hip angle	L89	
Knee angle	L90	
Foot angle	L91	

### Station Wagon – Cargo Space (NOT APPLICABLE)

Cargo length (open front)	L200	
Cargo length (open second)	L201	
Cargo length (closed front)	L202	
Cargo length (closed second)	L203	
Cargo length at belt (front)	L204	
Cargo length at belt (second)	L205	
Cargo width (wheelhouse)	W201	
Rear opening width at floor	W203	
Opening width at belt	W204	
Max. rear opening width above belt	W205	
Cargo height	H201	
Rear opening height	H202	
Tailgate to ground height	H250	
Front seat back to load floor height	H197	
Cargo volume index [m <sup>3</sup> (ft. <sup>3</sup> )]	V2	
Hidden cargo volume [m <sup>3</sup> (ft. <sup>3</sup> )]	V4	
Cargo volume index-rear of 2-seat	V10	

### Hatchback – Cargo Space

Cargo length at front seatback height	L208	945 (37.2)
Cargo length at floor (front)	L209	1692 (66.6)
Cargo length at second seatback height	L210	457 (18.0)
Cargo length at floor (second)	L211	838 (33.0)
Front seatback to load floor height	H197	478 (18.8)
Second seatback to load floor height	H198	389 (15.3)
Cargo volume index [m <sup>3</sup> (ft. <sup>3</sup> )]	V3	0.87 (30.6)
Hidden cargo volume [m <sup>3</sup> (ft. <sup>3</sup> )]	V4	--
Cargo volume index-rear of 2-seat	V11	0.35 (12.3)

### Aerodynamics\*

Wheel lip to ground, front	665.2 (26.2)
Wheel lip to ground, rear	657.9 (25.9)
Frontal area [m <sup>2</sup> (ft. <sup>2</sup> )]	1.9 (20.6) (a)
Drag coefficient (Cd)	

\* EPA Loaded Vehicle Weight, Loading Conditions

(a) Includes Two Outside Mirrors



**MVMA Specifications Form**  
**Passenger Car**  
**METRIC (U.S. Customary)**

Car Line SVO  
 Model Year 1986 Issued 9/85 Revised (•) \_\_\_\_\_

Body Type 2-DOOR HATCHBACK

**Vehicle Fiducial Marks**

Fiducial Mark Number*	Define Coordinate Location															
1 & 2 Front	<p>The rear vertical edge of the master control notch on the under side of the front door rocker panels locates the "X" coordinate relative to body grid and is located at the 444 (17.5) line.</p> <p>(Front Location)                      (Rear Location)</p> <p>X = 444    (17.5)                      X = 1295    (51)            Y = 737    (29)                      Y = 737    (29)            Z = -27.9 (-1.1)                      Z = -35.6 (-1.4)</p>															
3 & 4 Rear	<p>The intersection of the horizontal-vertical surfaces on the rocker panel door rabbet locates the "Y" and "Z" coordinates relative to body grid at particular fore-aft inch lines. The fore-aft location can be determined by the reference dimension from - Fiducial Mark 1 and 2.</p>															
Fiducial Mark Number																
Front	<table style="width: 100%; border-collapse: collapse;"> <tr><td style="width: 10%;">W21</td><td style="width: 15%;">737</td><td style="width: 15%;">(29)</td></tr> <tr><td>L54</td><td>444</td><td>(17.5)</td></tr> <tr><td>H81</td><td>-27.9</td><td>(-1.1)</td></tr> <tr><td>H161</td><td>--</td><td></td></tr> <tr><td>H163</td><td>--</td><td></td></tr> </table>	W21	737	(29)	L54	444	(17.5)	H81	-27.9	(-1.1)	H161	--		H163	--	
W21	737	(29)														
L54	444	(17.5)														
H81	-27.9	(-1.1)														
H161	--															
H163	--															
Rear	<table style="width: 100%; border-collapse: collapse;"> <tr><td style="width: 10%;">W22</td><td style="width: 15%;">737</td><td style="width: 15%;">(29)</td></tr> <tr><td>L55</td><td>1295</td><td>(51)</td></tr> <tr><td>H82</td><td>-35.6</td><td>(-1.4)</td></tr> <tr><td>H162</td><td>--</td><td></td></tr> <tr><td>H164</td><td>--</td><td></td></tr> </table>	W22	737	(29)	L55	1295	(51)	H82	-35.6	(-1.4)	H162	--		H164	--	
W22	737	(29)														
L55	1295	(51)														
H82	-35.6	(-1.4)														
H162	--															
H164	--															

\* Reference - SAE Recommended Practice, J182, Motor Vehicle Fiducial Marks.  
 All linear dimensions are in millimeters (inches).

**MVMA Specifications Form**  
**Passenger Car**  
**METRIC (U.S. Customary)**

Car Line SVO  
 Model Year 1986 Issued 9/85 Revised (●) \_\_\_\_\_

Body Type

2-DOOR HATCHBACK

**Lamps and Headlamp Shape\***

Height above ground to center of bulb or marker	Headlamp (SAE - H127)	Highest**	657.9 (25.9)	
		Lowest	--	
	Taillamp (SAE - H128)	Highest**	668.0 (26.3)	
		Lowest	470.7 (19.3)	
	Sidemarker	Front	650.2 (25.6)	
		Rear	622.3 (24.5)	
Distance from C/L of car to center of bulb	Headlamp	Inside	435.3 (17.1)	
		Outside**	510.3 (20.1)	
	Taillamp	Inside	668.0 (26.3)	
		Outside**	682.0 (26.9)	
	Directional	Front Outboard	707.9 (27.9)	
		Rear	462.8 (18.2)	
	Directional		Front Inboard	462.0 (18.2)
	Halogen headlamp (std., opt., n.a.)	Lo beam		Standard
Hi beam		--		
Replaceable bulb		Yes		
Shape		Single Rectangular Aero Lamps		
Headlamp other than above	Lo beam		N/A	
	Hi beam		N/A	
	Replaceable		N/A	
	Shape		N/A	
	Type		N/A	

\* Measured at curb mass (weight).  
 \*\* If single lamps are used enter here.

**MVMA Specifications Form  
Passenger Car**

Car Line SVO  
Model Year 1986 Issued 9/85 Revised (\*) \_\_\_\_\_

**METRIC (U.S. Customary)**

Model	Vehicle Mass (weight)							
	CURB MASS, kg. (weight, lb.)*			% PASS. MASS DISTRIBUTION				SHIPPING MASS, kg (weight, lb.)**
	Front	Rear	Total	Pass In Front		Pass In Rear		
Front				Rear	Front	Rear		
2.3L Turbo Engine w/5-Spd. Manual								
2-Door Hatchback	790 (1756)	623 (1384)	1413 (3140)	45	55	19	81	1359 (3019)

\* Reference - SAE J1100 Motor vehicle dimensions, curb weight definition.  
\*\* Shipping mass (weight) definition - Less Fuel and Engine Coolant



**MVMA Specifications Form**  
**Passenger Car**  
**METRIC (U.S. Customary)**

**Exterior Car And Body Dimensions – Key Sheet**

**Exterior Width**

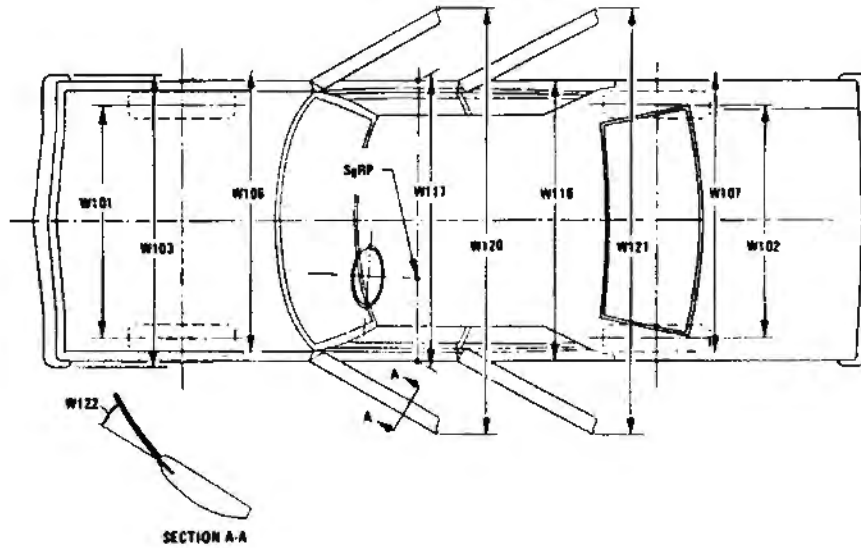

**Exterior Length & Height**

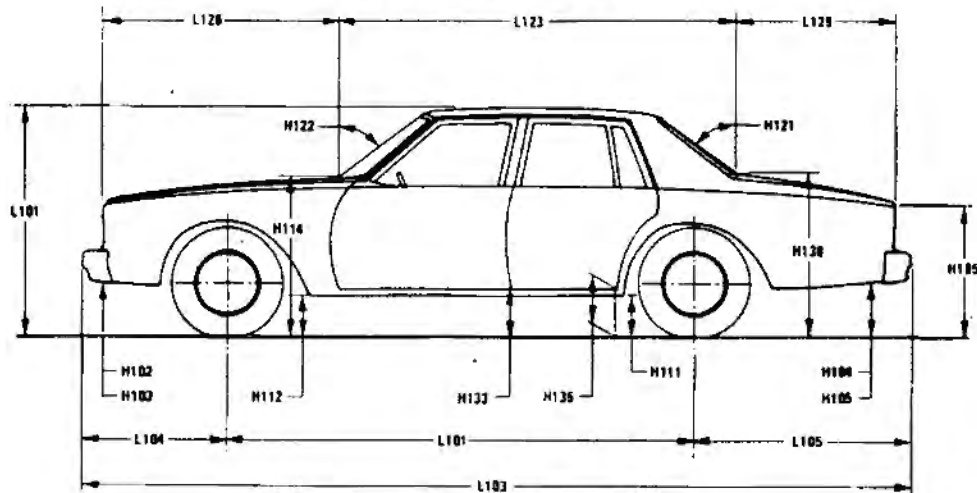

**Exterior Ground Clearance**

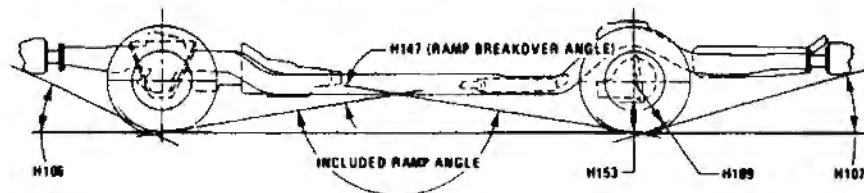

**MVMA Specifications Form**  
**Passenger Car**  
**METRIC (U.S. Customary)**

**Interior Car And Body Dimensions – Key Sheet**

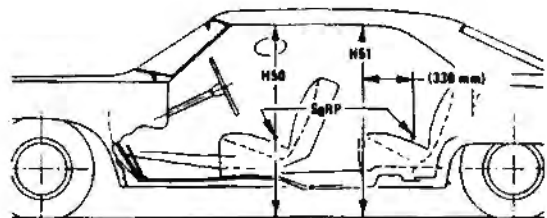
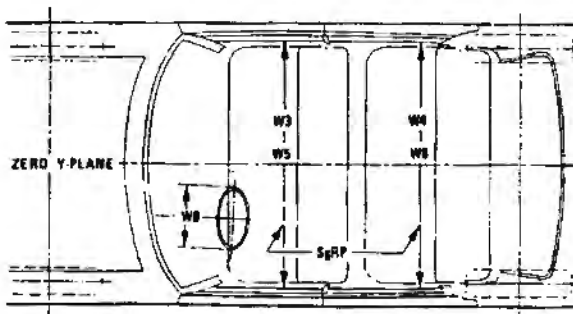
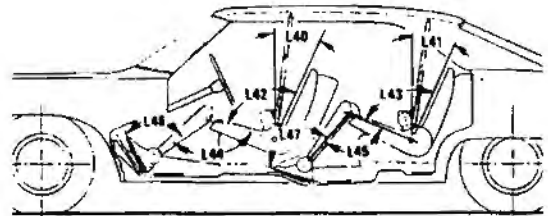
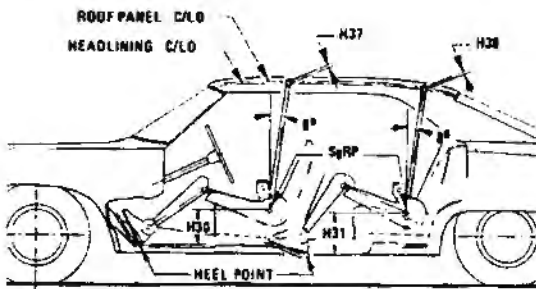
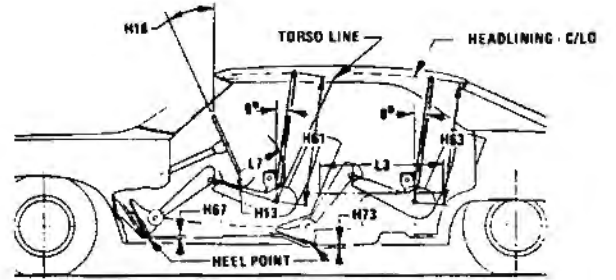
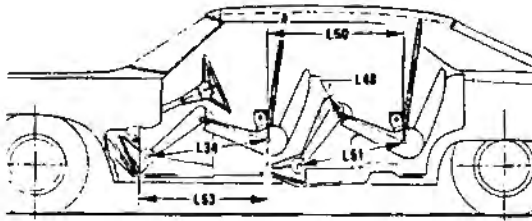

**MVMA Specifications Form**  
**Passenger Car**  
**METRIC (U.S. Customary)**

**Interior Car And Body Dimensions – Key Sheet**

**Third Seat**

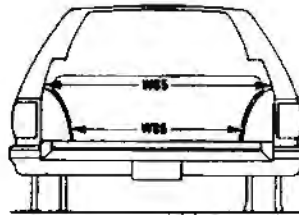
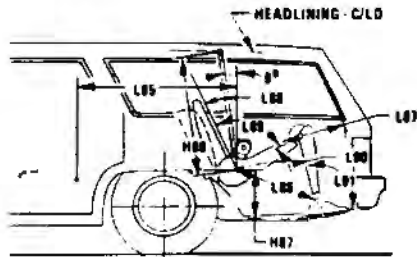

**Cargo Space**

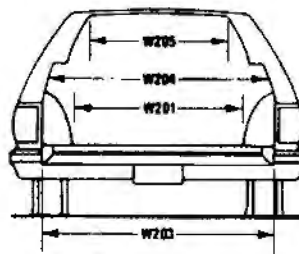
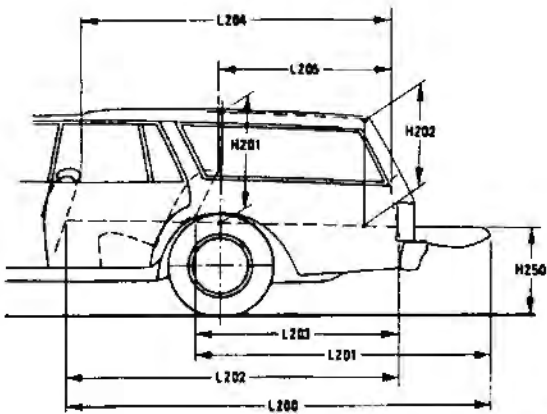

**Station Wagon**

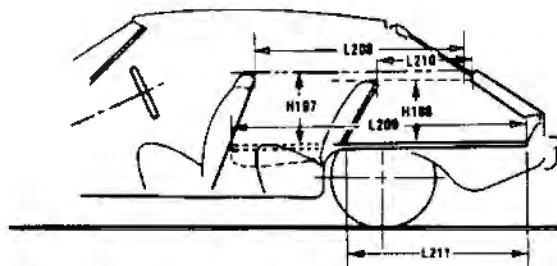

**Hatchback**

# MVMA Specifications Form

## Passenger Car

### METRIC (U.S. Customary)

#### Exterior Car And Body Dimensions – Key Sheet

##### Dimensions Definitions

#### Seating Reference Point

SEATING REFERENCE POINT means the manufacturer's design reference point which –

- (a) Establishes the rearmost normal design driving or riding position of each designated seating position in a vehicle;
- (b) Has coordinates established relative to the design vehicle structure;
- (c) Simulates the position of the pivot center of the human torso and thigh; and
- (d) Is the reference point employed to position the two dimensional templates described in SAE Recommended Practice J826, "Devices for Use in Defining and Measuring Vehicle Seating Accommodations."

#### Width Dimensions

- W101 TREAD–FRONT. The dimension measured between the tire centerlines at the ground.
- W102 TREAD–REAR. The dimension measured between the tire centerlines at the ground. In case of dual wheels, the dimension will be measured to the centerline of tire and wheel assemblies.
- W103 VEHICLE WIDTH. The maximum dimension measured between the widest point on the vehicle, excluding exterior mirrors, flexible mud flaps, marker lamps, but including bumpers, moldings, sheet metal protrusions or dual wheels, if standard equipment.
- W106 FRONT FENDER WIDTH. The dimension measured between the widest points at the front wheel centerline, excluding moldings.
- W107 REAR FENDER WIDTH. The dimension measured between the widest points at the rear wheel centerline, excluding moldings.
- W117 BODY WIDTH AT SgRP–FRONT. The dimension measured laterally between the widest points on the body at the SgRP-front, excluding door handles, applied moldings, or appliques.
- W120 VEHICLE WIDTH–FRONT DOORS OPEN. The dimension measured between the widest point on the front doors in maximum hold-open position.
- W121 VEHICLE WIDTH–REAR DOORS OPEN. The dimension measured between the widest point on the rear doors in maximum hold-open position. For vehicles with a rear door on only one side, this dimension is to the zero "Y" plane.
- W122 TUMBLE–HOME. STRAIGHT SIDE GLASS. The angle measured from a vertical to the outside surface of the front door glass at the SgRP "X" plane.  
CURVED SIDE GLASS. The angle measured from a vertical to a chord extending from the upper DLO to the lower DLO at the outside surface of the front door glass at the front SgRP "X" plane.

#### Length Dimensions

- L101 WHEELBASE (WB). The dimension measured longitudinally between front and rear wheel centerlines. In case of dual rear axles, the dimension shall be to the midpoint of the centerlines of the rear wheels.
- L103 VEHICLE LENGTH. The maximum dimension measured longitudinally between the foremost point and the rearmost point on the vehicle, including bumper, bumper guards, tow hooks and/or rub strips, if standard equipment.
- L104 OVERHANG–FRONT. The dimension measured longitudinally from the centerline of the front wheels to the foremost point on the vehicle including bumper, bumper guards, tow hooks and/or rub strips, if standard equipment.
- L105 OVERHANG–REAR. The dimension measured longitudinally from the centerline of the rear wheels; or in the case of

dual rear axles, the dimension shall be the midpoint of the centerlines of the rear wheels, to the rearmost point on the vehicle, including rear bumpers, bumper guards, tow hooks and rub strips, if standard equipment.

- L123 UPPER STRUCTURE LENGTH. The dimension measured longitudinally from the cowl point to the deck point.
- L125 COWL POINT "X" COORDINATE.
- L126 FRONT END LENGTH. The dimension measured longitudinally from the cowl point to the foremost point on the vehicle at the zero "Y" plane excluding ornamentation or bumpers. In cases where bumpers and/or grills are integrated with the profile, measurement is made at the foremost point of front end contour.
- L127 REAR WHEEL CENTERLINE "X" COORDINATE or in the case of dual rear axles, the coordinate shall be the midpoint of the distance between the rear axle centerlines.
- L129 REAR END LENGTH. The dimension measured longitudinally from the deck point to the rearmost visible point of the body sheet metal at the zero "Y" plane, excluding ornamentation or bumpers.

#### Height Dimensions

- H101 VEHICLE HEIGHT. The dimension measured vertically from the highest point on the vehicle body to ground.
- H111 ROCKER PANEL–REAR TO GROUND. The dimension measured vertically from the bottom of the rocker or side quarter panel at the front of the rear wheel opening, excluding flanges, to ground.
- H112 ROCKER PANEL–FRONT TO GROUND. The dimension measured vertically from the foremost point on the bottom of the rocker panels, excluding flanges, to ground.
- H114 COWL POINT TO GROUND. Measured at zero "Y" plane.
- H121 BACKLIGHT SLOPE ANGLE. The angle between the vertical reference line and the surface of backlight at vehicle zero "Y" plane. For curve backlight, the angle is to chord of backlight arc from lower DLO to upper DLO.
- H122 WINDSHIELD SLOPE ANGLE. The angle between the vertical reference line and a chord of the windshield arc running from the lower DLO to the upper DLO at the vehicle zero "Y" plane. In the case of wrap over glass, the angle to be measured will be formed by a chord 457 mm (18.0 in) long drawn from the lower DLO to the intersecting point on the windshield.
- H127 HEADLAMP TO GROUND–CURB MASS (WT.). The dimension measured vertically from the centerline of the lowest headlamp lens to ground.
- H128 TAILLAMP TO GROUND–CURB MASS (WT.). The dimension measured vertically from the centerline of the upper bulb to ground.
- H133 BOTTOM OF DOOR CLOSED–FRONT TO GROUND. The dimension measured vertically from the bottom outside corner of the door on the lock pillar side, in maximum closed position, to ground.
- H135 BOTTOM OF DOOR CLOSED–REAR TO GROUND. The dimension measured vertically from the bottom outside corner of the door on the lock pillar side, in maximum closed position, to ground.
- H138 DECK POINT TO GROUND. Measured at zero "Y" plane.

#### Ground Clearance Dimensions

- H102 FRONT BUMPER TO GROUND. The minimum dimension measured vertically from the lowest point on the front bumper to ground, including bumper guards, if standard equipment.
- H103 FRONT BUMPER TO GROUND–CURB MASS (WT.). Measured in the same manner as H102.



# MVMA Specifications Form

## Passenger Car

### METRIC (U.S. Customary)

#### Interior Car And Body Dimensions – Key Sheet

##### Dimensions Definitions

H104	REAR BUMPER TO GROUND. The minimum dimension measured vertically from the lowest point on the rear bumper to ground, including bumper guards, if standard equipment.	L34	MAXIMUM EFFECTIVE LEG ROOM-ACCELERATOR. The dimension measured along a line from the ankle pivot center to the SgRP-front plus 254 mm (10.0 in) measured with right foot on the undepressed accelerator pedal. For vehicles with SgRP to heel (H30) greater than 18 in., the accelerator pedal may be depressed as specified by the manufacturer. If the accelerator is depressed, the manufacturer shall place foot flat on pedal and note the depression of the pedal.
H105	REAR BUMPER TO GROUND – CURB MASS (WT.). Measured in the same manner as H104.	L40	BACK ANGLE-FRONT. The angle measured between a vertical line through the SgRP-front and the torso line. If the seatback is adjustable, use the normal driving and riding position specified by the manufacturer.
H106	ANGLE OF APPROACH. The angle measured between a line tangent to the front tire static loaded radius arc and the initial point of structural interference forward of the front tire to ground. The limiting structural component shall be designated.	L42	HIP ANGLE-FRONT. The angle measured between torso line and thigh centerline.
H107	ANGLE OF DEPARTURE. The angle measured between a line tangent to the rear tire static loaded radius arc and the initial point of structural interference rearward of the rear tire to ground. The limiting component shall be designated.	L44	KNEE ANGLE-FRONT. The angle measured between thigh centerline and lower leg centerline measured on the right leg.
H147	RAMP BREAKOVER ANGLE. The angle measured between two lines tangent to the front and rear tire static loaded radius and intersecting at a point on the underside of the vehicle which defines the largest ramp over which the vehicle can roll.	L46	FOOT ANGLE-FRONT. The angle measured between the lower leg centerline and a line tangent to the ball and heel of the bare foot flesh line measured on the right leg. Ref SAE J826.
H153	REAR AXLE DIFFERENTIAL TO GROUND. The minimum dimension measured from the rear axle differential to ground.	L53	SgRP-FRONT TO HEEL. The dimension measured horizontally from the SgRP-front to the accelerator heel point.
H156	MINIMUM RUNNING GROUND CLEARANCE. The minimum dimension measured from the sprung vehicle to ground. Specify location.	W3	SHOULDER ROOM-FRONT. The minimum dimension measured laterally between the trimmed surfaces on the "X" plane through the SgRP-front at height between the belt line and 254 mm (10.0 in.) above the SgRP-front, excluding the door assist strap and attaching parts.
<b>Glass Areas</b>			
S1	Windshield area.	W5	HIP ROOM-FRONT. The minimum dimension measured laterally between the trimmed surfaces on the "X" plane through the SgRP-front within 25 mm (1.0 in.) below and 76 mm (3.0 in.) above the SgRP-front and 76 mm (3.0 in.) fore and aft of the SgRP-front.
S2	Side windows area. Includes the front door, rear door, vents, and rear quarter windows on both sides of the vehicle.	W9	STEERING WHEEL MAXIMUM OUTSIDE DIAMETER. Define if other than round.
S3	Backlight areas.	H13	STEERING WHEEL TO CENTERLINE OF THIGH. The minimum dimension measured from the bottom of steering wheel, with front wheels in the straight position, to the thigh centerline.
S4	Total area. Total of all areas (S1 + S2 + S3).	H17	ACCELERATOR HEEL POINT TO THE STEERING WHEEL CENTER. The dimension measured vertically from the AHP-front to the intersection of the steering column centerline to a plane tangent to the upper surface of the steering wheel rim.
<b>Fiducial Mark Dimensions</b>			
<b>Fiducial Mark – Number 1</b>			
L54	"X" coordinate.	H18	STEERING WHEEL ANGLE. The angle measured from a vertical to the surface plane of the steering wheel.
W21	"Y" coordinate.	H30	SgRP-FRONT TO HEEL. The dimension measured vertically from the SgRP-front to the accelerator heel point.
H81	"Z" coordinate.	H37	HEADLINING TO ROOF PANEL-FRONT. The dimension measured from the intersection of the headlining and the extended effective head room line normal to the sheet metal.
H161	Height "Z" coordinate to ground at curb weight.	H50	UPPER BODY OPENING TO GROUND-FRONT. The dimension measured vertically from the trimmed body opening to the ground on the SgRP-front "X" plane.
H163	Height "Z" coordinate to ground.	H61	EFFECTIVE HEAD ROOM-FRONT. The dimension measured along a line 8 deg. rear of vertical from the SgRP-front to the headlining plus 102 mm (4.0 in.).
<b>Fiducial Mark – Number 2</b>			
L55	"X" coordinate.	H67	FLOOR COVERING THICKNESS-UNDEPRESSED-FRONT. The dimension measured vertically from the surface of the undepressed floor covering to the underbody sheet metal at the accelerator heel point.
W22	"Y" coordinate.	PD1	PASSENGER DISTRIBUTION-FRONT.
W82	"Z" coordinate.	<b>Rear Compartment Dimensions</b>	
H162	Height "Z" coordinate to ground at curb weight.	L3	COMPARTMENT ROOM-SECOND. The dimension measured horizontally from the back of front seat to the front of the second seatback at a height tangent to the top of the second seat cushion.
H164	Height "Z" coordinate to ground.		
<b>Front Compartment Dimensions</b>			
L7	STEERING WHEEL TORSO CLEARANCE. The minimum dimension measured in the side view from the rearmost edge of the steering wheel, with front wheels in the straight ahead position, to the torso line.		
L11	ACCELERATOR HEEL POINT TO STEERING WHEEL CENTER. The dimension measured horizontally from the AHP to the intersection of the steering column centerline and a plane tangent to the upper surface of the steering wheel rim.		
L17	DESIGN H-POINT-FRONT TRAVEL. The dimension measured horizontally between the design H-point-front in the foremost and rearmost seat track positions.		
L23	NORMAL DRIVING AND RIDING SEAT TRACK LEVEL. The dimension measured horizontally between a point on the design H-point travel line from the SgRP to the displaced point on the design H-point travel line with the seat moved to the foremost seat position, but not to include seat track travel used for purposes other than normal driving and riding positions.		
L31	SgRP-FRONT. "X" COORDINATED.		

# MVMA Specifications Form

## Passenger Car

### METRIC (U.S. Customary)

#### Interior Car And Body Dimensions – Key Sheet

##### Dimensions Definitions

- L41 BACK ANGLE-SECOND. The angle measured between a vertical line through the SgRP – second and the torso line.
- L43 HIP ANGLE-SECOND. The angle measured between torso line and thigh centerline.
- L45 KNEE ANGLE-SECOND. The angle measured between thigh centerline and lower leg centerline.
- L47 FOOT ANGLE-SECOND. The angle measured between the lower leg centerline and a line tangent to the ball and heel of the three-dimensional devices bare foot flesh line (Reference J826).
- L48 KNEE CLEARANCE-SECOND. The minimum dimension measured from the knee pivot center to the back of front seatback minus 51 mm (2.0 in.).
- L50 SgRP COUPLE DISTANCE-SECOND. The dimension measured horizontally from the driver SgRP-front to the SgRP-second.
- L51 MINIMUM EFFECTIVE LEG ROOM-SECOND. The dimension measured along a line from the ankle pivot center to the SgRP-second plus 254mm (10.0 in.).
- W4 SHOULDER ROOM-SECOND. The minimum dimension measured laterally between door or quarter trimmed surfaces on the "X" plane through the SgRP-second at height between 254-406 mm (10.0-16.0 in.) above the SgRP-second, excluding the door assist straps and attaching parts.
- W6 HIP ROOM-SECOND. Measured in the same manner as W5.
- H31 SgRP-SECOND TO HEEL. The dimension measured vertically from the SgRP-second to the two dimensional device heel point on the depressed floor covering.
- H38 HEADLINING TO ROOF PANEL-SECOND. The dimension measured from the intersection of the headlining and the extended effective head room line normally to the roof sheet metal.
- H51 UPPER BODY OPENING TO GROUND-SECOND. The dimension measured vertically from the trimmed body opening to the ground on the "X" plane 330 mm (13.0 in) forward of the SgRP-second.
- H63 EFFECTIVE HEAD ROOM-SECOND. The dimension measured along a line 8 deg rear of vertical from the SgRP to the headlining, plus 102 mm (4.0 in).
- H73 FLOOR COVERING-DEPRESSED-SECOND. The dimension measured vertically from the heel point to the underbody sheet metal.
- PD2 PASSENGER DISTRIBUTION-SECOND.

#### Luggage Compartment Dimensions

- V1 USABLE LUGGAGE CAPACITY-Total of volumes of individual pieces of standard luggage set plus H-boxes stowed in the luggage compartment in accordance with the procedure described in paragraph 8.2 of SAE-J1100.
- H195 LIFTOVER HEIGHT. The dimension measured vertically from the luggage compartment lower opening at the zero "Y" plane to ground.

#### Interior Volumes (EPA Classification)

The Interior Volume Index is listed for each body style except two seaters. The interior volume index estimates the space in a car. It is based on four measurements – head room, shoulder room, hip room, and leg room – for the front and rear seats, plus trunk capacity. The interior volume index is an estimate of the size of the passenger compartment.

The Trunk/Cargo Index is an estimate of the size of the trunk/cargo space. In station wagons and hatchbacks it is an estimate of the space behind the second seat.

#### Station Wagon – Third Seat Dimensions

- L85 SgRP COUPLE DISTANCE-THIRD. The dimension measured horizontally from the SgRP-second to the SgRP-third.
- L86 EFFECTIVE LEG ROOM-THIRD. The dimension measured along a line from the ankle pivot center to the SgRP-third plus 254 mm (10.0 in).
- L87 KNEE CLEARANCE-THIRD. The minimum dimension from the knee pivot center to the back of second seatback minus a constant of 51 mm (2.0 in). With rear-facing third seat, dimension is measured to closure.
- L88 BACK ANGLE-THIRD. Measured in the same manner as L41.
- L89 HIP ANGLE-THIRD. Measured in the same manner as L43.
- L90 KNEE ANGLE-THIRD. Measured in the same manner as L45.
- L91 FOOT ANGLE-THIRD. Measured in the same manner as L47.
- W85 SHOULDER ROOM-THIRD. Measured in the same manner as W4.
- W86 HIP ROOM-THIRD. Measured in the same manner as W5.
- H86 EFFECTIVE HEAD ROOM-THIRD. The dimension, measured along a line 8 deg. rear from the SgRP-third to the headlining rear of vertical plus a constant of 102 mm (4.0 in.).
- PD3 PASSENGER DISTRIBUTION-THIRD.
- SD1 SEAT FACING DIRECTION-THIRD.

#### Station Wagon – Cargo Space Dimensions

- L200 CARGO LENGTH-OPEN-FRONT. The minimum dimension measured longitudinally from the back of the front seatback at the height of the undepressed floor covering to the rearmost point on the undepressed floor covering on the open tailgate or cargo surface if the rear closure is a conventional door type tailgate at the zero "Y" plane.
- L201 CARGO LENGTH-OPEN-SECOND. The dimension measured longitudinally from the back of the second seatback at the height of the undepressed floor covering to the rearmost point on the undepressed floor covering on the open tailgate or cargo floor surface if the rear closure is a conventional door type tailgate, at the zero "Y" plane.
- L202 CARGO LENGTH-CLOSED-FRONT. The minimum dimension measured horizontally from the back of the front seat at the height of the undepressed floor covering to the rearmost point on the undepressed floor covering on the closed tailgate or taildoor for station wagons, trucks and mpv's at the zero "Y" plane.
- L203 CARGO LENGTH-CLOSED-SECOND. The dimension measured horizontally from the back of the second seat at the height of the undepressed floor covering to the rearmost point on the undepressed floor covering on the closed tailgate or taildoor for station wagons, trucks and mpv's at the zero "Y" plane.
- L204 CARGO LENGTH AT BELT-FRONT. The minimum dimension measured horizontally from the back of the front seatback at the seatback top to the foremost normal surface of the closed tailgate or inside surface of the cab backpanel at the height of the belt, on the zero "Y" plane.
- L205 CARGO LENGTH AT BELT-SECOND. The minimum dimension measured horizontally from the back of the second seatback at the seatback top to the foremost normal surface of the closed tailgate at the height of the belt, on the zero "Y" plane.
- W201 CARGO WIDTH-WHEELHOUSE. The minimum dimension measured laterally between the trimmed wheelhousings at floor level. For any vehicle not trimmed, measure to the sheet metal.

# MVMA Specifications Form Passenger Car

METRIC (U.S. Customary)

## Interior Car And Body Dimensions – Key Sheet Dimensions Definitions

- W203 REAR OPENING WIDTH AT FLOOR. The minimum dimension measured laterally between the limiting interferences of the rear opening at floor level.
- W204 REAR OPENING WIDTH AT BELT. The minimum dimension measured laterally between the limiting interferences of the rear opening at belt height or top of pick up box.
- W205 REAR OPENING WIDTH ABOVE BELT. The minimum dimension measured laterally between the limiting interferences of the rear opening above the belt height.
- H197 FRONT SEATBACK TO LOAD FLOOR HEIGHT. The dimension measured vertically from the horizontal tangent to the top of the seatback to the undepressed floor covering.
- H201 CARGO HEIGHT. The dimension measured vertically from the top of the undepressed floor covering to the headlining at the rear wheel "X" coordinate on the zero "Y" plane.
- H202 REAR OPENING HEIGHT. The dimension measured vertically from the top of the undepressed floor covering to the upper trimmed opening on the zero "Y" plane with rear door fully open.
- H250 TAILGATE TO GROUND CURB MASS (WT.). The dimension measured vertically from the top of the undepressed floor covering on the lowered tailgate to ground on the zero "Y" plane.
- V2 STATION WAGON  
Measured in inches:  

$$\frac{W4 \times H201 \times L204}{1728} = \text{ft}^3$$
 Measured in mm:  

$$\frac{W4 \times H201 \times L204}{10^9} = \text{m}^3 \text{ (cubic meter)}$$
- V4 HIDDEN LUGGAGE CAPACITY-REAR OF FRONT SEAT. The total volumes of individual pieces of one set of standard luggage stowed in any hidden cargo area below the load floor rear of the front seat.
- V5 TRUCKS AND MPV'S WITH OPEN AREA.  
Measured in inches:  

$$\frac{L506 \times W500 \times H503}{1728} = \text{ft}^3$$
 Measured in mm:  

$$\frac{L506 \times W500 \times H503}{10^9} = \text{m}^3 \text{ (cubic meter)}$$
- V6 TRUCKS AND MPV'S WITH CLOSED AREA.  
Measured in inches:  

$$\frac{L204 \times W500 \times H505}{1728} = \text{ft}^3$$
 Measured in mm:  

$$\frac{L204 \times W500 \times H505}{10^9} = \text{m}^3 \text{ (cubic meter)}$$
- V8 HIDDEN LUGGAGE CAPACITY-REAR OF SECOND SEAT. The total volume of individual pieces of one set of standard luggage stowed in any hidden cargo area below the load floor rear of the second seat.
- V10 STATION WAGON CARGO VOLUME INDEX. Usable luggage (one (1) stand and luggage set) below floor.  
Measured in inches:  

$$\frac{H201 \times L205 \times \frac{W4 + W201}{2}}{1728} = \text{ft}^3$$
 Measured in mm:  

$$\frac{H201 \times L205 \times \frac{W4 + W201}{2}}{10^9} = \text{m}^3 \text{ (cubic meter)}$$

## Hatchback – Cargo Space Dimensions

All hatchback cargo dimensions are to be taken with the front seat in full down and rear position, and the rear seat folded down. The hatchback door is in the closed position. (For electrically adjusted seats, see the manufacturer's specifications for Design "H" Point).

- L208 CARGO LENGTH AT FRONT SEATBACK HEIGHT. The minimum horizontal dimension from the "X" plane tangent to the rearmost surface of the driver's seatback to the inside limiting interference of the hatchback door on the vehicle zero "Y" plane.
- L209 CARGO LENGTH AT FLOOR-FRONT-HATCHBACK. The minimum horizontal dimension measured at floor level from the rear of the front seatback to the normal limiting interference of the hatchback door on the vehicle zero "Y" plane.
- L210 CARGO LENGTH AT SECOND SEATBACK HEIGHT-HATCHBACK. The minimum dimension measured from the "X" plane tangent to the rearmost surface of second seatback or the load floor which is stowed at least one half of the H198 dimension height above the rear load floor, to the rearmost inside limiting interference on the zero "Y" plane.
- L211 CARGO LENGTH AT FLOOR-SECOND HATCHBACK. The minimum horizontal dimension measured at floor level from the rear of the second seatback or load floor panel to the normal limiting interference of the hatchback door on the vehicle zero "Y" plane.
- H197 FRONT SEATBACK TO LOAD HEIGHT. The dimension measured vertically from the horizontal tangent to the top of the seatback to the undepressed floor covering.
- H198 SECOND SEATBACK TO LOAD FLOOR HEIGHT: The dimension measured vertically from the second seat back to the undepressed floor covering.
- V3 HATCHBACK.  
Measured in inches:  

$$\frac{L208 + L209}{2} \times W4 \times H197 = \text{ft}^3$$
 Measured in mm:  

$$\frac{L208 + L209}{2} \times W4 \times H197 = \text{m}^3 \text{ (cubic meter)}$$
- V4 HIDDEN LUGGAGE CAPACITY-REAR OF FRONT SEAT. The total volumes of individual pieces of one set of standard luggage stowed in any hidden cargo area below the load floor rear of the front seat.
- V11 HATCHBACK CARGO VOLUME INDEX. Usable luggage (one (1) stand and luggage set) below floor.  
Measured in inches:  

$$\frac{L210 + L211}{2} \times W4 \times H198 = \text{ft}^3$$
 Measured in mm:  

$$\frac{L210 + L211}{2} \times W4 \times H198 = \text{m}^3 \text{ (cubic meter)}$$

# MVMA Specifications Form

## Passenger Car

### METRIC (U.S. Customary)

#### Index

Subject	Page No.	Subject	Page No.
Aerodynamics	22	Interior Volumes	21
Alternator	18	Instruments	15
Automatic Transmission/Transaxle	8, 9	Lamps and Headlamp Shape	24
Axis, Steering	14	Legroom	21, 22
Axle, Drive, Front, Rear	2, 9, 10	Lengths - Car and Body	20
Axle Shafts	10	Leveling, Suspension	11
Battery	16	Lifters, Valve	4
Body and Miscellaneous Information	17	Linings - Clutch, Brake	8, 12
Brakes-Parking, Service	12, 13	Lubrication - Engine Transmission/Transaxle	4, 8, 9
Camber	15	Luggage Compartment	21
Camshaft	3	Mass	25, 26
Capacities		Models	1
Cooling System	5	Motor Starting	16
Fuel Tank	6	Muffler	7
Lubricants		Passenger Capacity	1
Engine Crankcase	4	Passenger Mass Distribution	25
Transmission/Transaxle	8, 9	Pistons	3
Rear Axle	10	Power Brakes	12
Car Models	1	Power, Engine	2
Car and Body Dimensions		Power Steering	14
Width	20	Power Teams	2
Length	20	Propeller Shaft, Universal Joints	10
Height	20	Pumps - Fuel	6
Ground Clearance	20	Water	5
Front Compartment	21	Radiator - Cap, Hoses, Core	5
Rear Compartment	21	Ratios - Axle, Transaxle	2, 9
Luggage Compartment	21	Compression	2
Station Wagon - Third Seat	22	Steering	14
Station Wagon - Cargo Space	22	Transmission/Transaxle	2, 8, 9
Hatchback - Cargo Space	22	Rear Axle	2, 9, 10
Carburetor	2, 6	Regulator - Generator	16
Caster	15	Restraint System	18
Choke, Automatic	6	Rims	13
Clutch - Pedal Operated	8	Rods - Connecting	4
Coil, Ignition	16	Scrub Radius	14
Connecting Rods	4	Seats	17
Convenience Equipment	19	Shock Absorbers, Front & Rear	11
Cooling System	5	Spark Plugs	16
Crankshaft	4	Speedometer	15
Cylinders and Cylinder Head	3	Springs - Front & Rear Suspension	11
Diesel Information	4	Stabilizer (Sway Bar) - Front & Rear	11
Dimension Definitions		Starting System	16
Key Sheet - Exterior	27, 30, 31	Steering	14
Key Sheet - Interior	28, 29, 31, 32, 33	Suppression - Ignition, Radio	16
Electrical System	15, 16	Suspension - Front & Rear	11
Emission Controls	7	Tail Pipe	7
Engine - General		Theft Protection	19
Bore, Stroke, Type	3	Thermostat, Cooling	5
Compression Ratio	2	Tires	13
Displacement	2, 3	Toe-In	15
Firing Order, Cylinder Numbering	3	Torque Converter	9
General Information, Power & Torque	2	Torque - Engine	2, 8, 9
Intake System	4	Transaxle	9
Power Teams	2	Transmission - Types	2, 8, 9
Exhaust System	7	Transmission - Automatic	2, 8, 9
Equipment Availability, Convenience	19	Transmission - Manual	2, 8, 9
Fan, Cooling	5	Transmission - Ratios	2, 9
Fiducial Marks	23	Tread	20
Filters - Engine Oil, Fuel System	4	Trunk Cargo Load	1
Frame	17	Trunk Luggage Capacity	21
Front Suspension	11	Turning Diameter	14
Front Wheel Drive Unit	10	Unitized Construction	17
Fuel System	6	Universal Joints, Propeller Shaft	10
Fuel Injection	6	Valve System	4
Fuel Tank	6	Voltage Regulator	16
Generator and Regulator	16	Water Pump	5
Glass	18	Weights	25, 26
Headroom - Body	21, 22	Wheel Alignment	15
Heights - Car and Body	20	Wheelbase	20
Horns	15	Wheels & Tires	13
Horsepower - Brake	2	Wheel Spindle	14
Ignition System	16	Widths - Car and Body	20
Inflation - Tires	13	Windshield	18
		Windshield Wiper and Washer	15