



PAST EXAM PAPERS AND MEMOS
Get All Your Engineering Past Exam Papers With Answers

Website: www.previouspapers.co.za

Email: info@previouspapers.co.za

CELL: 073 770 3028

PAST EXAM PAPER & MEMO N1

ABOUT THE QUESTION PAPERS AND ONLINE INSTANT ACCESS:

THANK YOU FOR DOWNLOADING THE PAST EXAM PAPER AND ITS MEMO, WE HOPE IT WILL BE OF HELP TO YOU. SHOULD YOU NEED MORE QUESTION PAPERS AND THEIR MEMOS PLEASE SEND US AN EMAIL TO INFO@PREVIOUSPAPERS.CO.ZA AND WE WILL SEND YOU A FULL DOWNLOAD VERSION OF THESE THOUGH A FULL DOWNLOAD COMES AT A COST.

ALTERNATIVELY YOU CAN PURCHASE THEM ONLINE FROM OUR WEBSITE WWW.PREVIOUSPAPERS.CO.ZA TO AVOID DELAYS AND YOU FOLLOW ALL THE NEEDED STEPS TO GET INSTANT DOWNLOAD. **WITH ONLINE PAYMENT YOU CAN GET INSTANT DOWNLOADS OF YOUR PURCHASE.**

WE SELL PREVIOUS PAPERS AND MEMOS FOR THE SUBJECTS MENTIONED AND THE PAPERS ARE BETWEEN 2014-2019. THE PAPERS ARE IN PDF FORM AND EACH PDF HAS A MINIMUM OF SEVEN DIFFERENT PAPERS. THE YEARS FOR THE PAPERS YOU ARE PURCHASING ARE ALSO INCLUDED ON THE WEBSITE.

PRICE OF THE PAPERS AT A BIG DISCOUNT

Previous papers are very important in ensuring you pass your final exams. The actual value of the papers we are making you access is way more than R1 000 and we are making these very cheap as we have you in mind. For a small amount you can have these papers.

THE COST PER SUBJECT IS R300.



higher education & training

Department:
Higher Education and Training
REPUBLIC OF SOUTH AFRICA

T560(E)(A6)T
APRIL EXAMINATION

NATIONAL CERTIFICATE

ENGINEERING SCIENCE N1

(15070391)

6 April 2016 (X-Paper)
9:00–12:00

This question paper consists of 10 pages and 1 formula sheet.

DEPARTMENT OF HIGHER EDUCATION AND TRAINING
REPUBLIC OF SOUTH AFRICA
NATIONAL CERTIFICATE
ENGINEERING SCIENCE N1
TIME: 3 HOURS
MARKS: 100

INSTRUCTIONS AND INFORMATION

1. Answer ALL the questions.
 2. Read ALL the questions carefully.
 3. Number the answers according to the numbering system used in this question paper.
 4. You may start with any question but sub-questions must be kept in order and not split or separated.
 5. Calculations must contain the following:
 - 5.1 Formula
 - 5.2 Substitution and conversion of values
 - 5.3 Answer
 6. Answers to calculations must at all times be given correctly to three decimal numbers.
 7. Neat, labelled line sketches must be drawn with the necessary drawing equipment.
 8. Use $g = 9,8 \text{ m}\cdot\text{s}^{-1}$.
 9. Write neatly and legibly.
-

QUESTION 1

1.1 Various options are given as possible answers to the following questions. Choose the answer and write only the letter (A–D) next to the question number (1.1.1–1.1.4) in the ANSWER BOOK.

1.1.1 A vector can be defined as ...

- A a physical quantity having no magnitude as well as no direction.
- B a physical quantity having a specific magnitude only and no specific direction.
- C a physical quantity having a specific magnitude as well as direction.
- D the attraction between the earth and a body.

1.1.2 Displacement can be defined as ...

- A actual route a body followed.
- B a physical quantity having a specific magnitude as well as direction.
- C the amount of matter a body consists of.
- D the straight line route a body followed from starting point to ending point.

1.1.3 Mass can be defined as ...

- A a physical quantity having a specific magnitude as well as direction.
- B the amount of matter a body consists of.
- C the rate of change of distance.
- D the attraction between the earth and a body.

1.1.4 Velocity can be defined as ...

- A the rate of change of displacement.
- B the attraction between the earth and a body.
- C the rate of change of distance.
- D a physical quantity having a specific magnitude only and no specific direction.

(4 x 1) (4)

1.2 In soccer practice Thato runs 74 m in a direction of $W30^{\circ}S$, he turns around and walks 22 m in a direction of 30° North of East.

Graphically determine the resultant displacement of Thato by means of addition of vectors. (2)

1.3 An aeroplane flies due east for 15 min at an average velocity of 375 km/h.

1.3.1 Calculate the displacement of the aeroplane.

1.3.2 How long will it take the pilot to do the same flight if the average velocity of the aeroplane is increased by 25%?

(2 x 2) (4)

1.4 The following readings were taken while testing a machine part:

Velocity in m/s:	0	15	20	25	30	35	40
Time taken in seconds:	0	5	10	15	20	25	30

1.4.1 Draw a velocity-time graph according to the following scale: 5 sec = 2 cm and 5 m/s = 1 cm.

(3)

1.4.2 Calculate from the graph the average acceleration of the machine part.

(2)

[15]

QUESTION 2

2.1 Indicate whether the following statements are TRUE or FALSE. Choose the answer and write only 'true' or 'false' next to the question number (2.1.1–2.1.5) in the ANSWER BOOK.

2.1.1 Force is a scalar.

2.1.2 The resultant of a system of forces is that single force which balances two or more forces.

2.1.3 The moment of a force about a point is the sum of the force and the perpendicular distance from the point of action.

2.1.4 Mechanical advantage is the ratio between the load and the effort of the machine.

2.1.5 The equilibrant is the single force that has the same effect as the combined effect of the forces.

(5 x 1) (5)

2.2 A pulley system with a velocity ratio of 3 is used to lift a weight of 550 N, 3,5 m high.

2.2.1 Calculate the effort distance.

2.2.2 If the mechanical advantage is 2,5 what is the magnitude of the effort?

(2 x 2) (4)

2.3 A lathe with a weight of 7,5 kN hangs from a crane hook by two chains. The two chains form angles of 40° and 50° respectively with the horizontal plane.

Determine the tensile forces in the chains. (3)

2.4 Determine the value of the unknown force which will keep the system in equilibrium as shown in FIGURE 1.

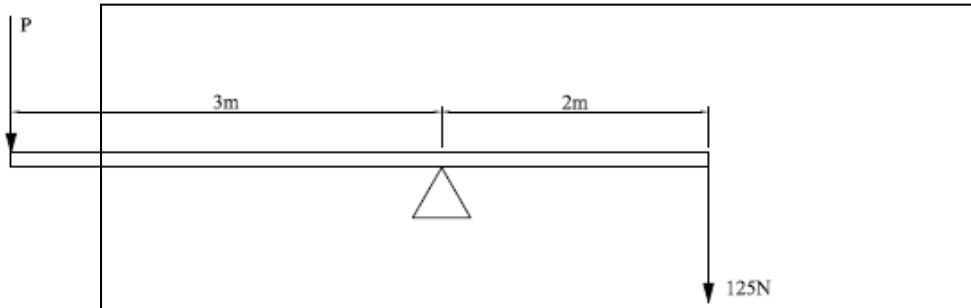

FIGURE 1

(2)

2.5 Determine the equilibrant of the two forces given in FIGURE 2 by using the parallelogram method.

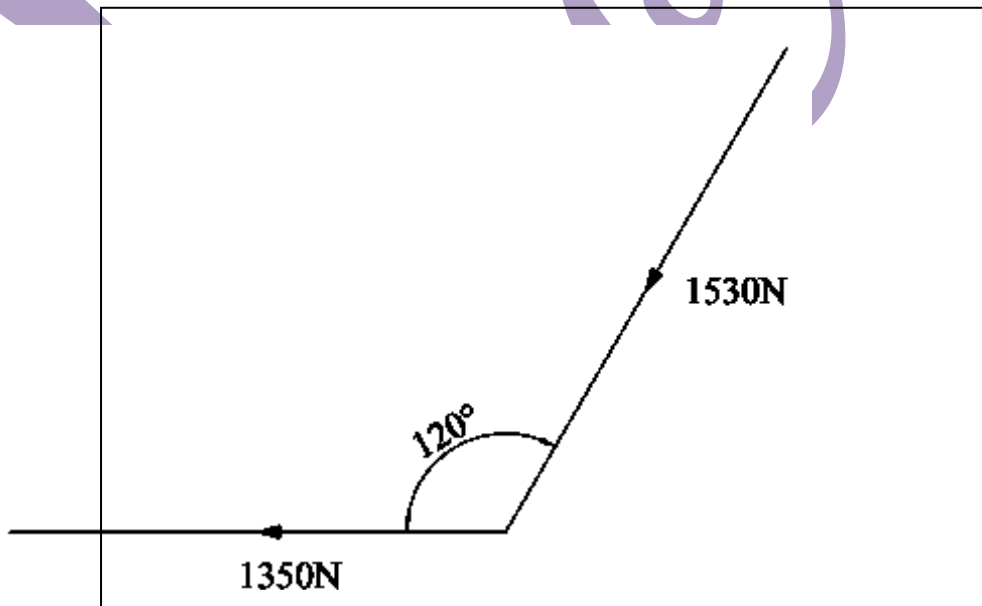

FIGURE 2

(3)
[17]

QUESTION 3

3.1 Various options are given as possible answers to the following questions. Choose the answer and write only the letter (A–D) next to the question number (3.1.1–3.1.5) in the ANSWER BOOK.

3.1.1 The definition of potential energy can be stated as ...

- A the energy that is produced by the movement of electrons in a circuit.
- B the energy a body possesses due to its position above the ground plane.
- C the energy a body possesses due to a chemical reaction taking place.
- D the energy that is created by the generation of heat.

3.1.2 Work can be defined as ...

- A when a force moves through a distance.
- B the energy a body possesses due to its position above the ground plane.
- C the rate of doing work.
- D the energy that is produced by the movement of electrons in a circuit.

3.1.3 The definition of kinetic energy can be stated as ...

- A when a force moves through a distance.
- B the energy a body possesses due to its motion.
- C the energy that is created by the generation of heat.
- D the energy that is produced by the movement of electrons in a circuit.

3.1.4 Power is defined as ...

- A the rate of doing work.
- B the energy a body possesses due to a chemical reaction taking place.
- C the energy a body possesses due to its position above the ground plane.
- D when a force moves through a distance.

3.1.5 Electrical energy can be defined as ...

- A the energy a body possess due to a chemical reaction taking place.
- B the energy that is produced by the movement of electrons in a circuit.
- C the energy that is created by the generation of heat.
- D the energy a body possess due to its motion.

(5 x 1) (5)

- 3.2 A man has to push his car for 200 m to get it to start. The force needed to push the car is 525 N.
Calculate the work done by the man. (2)
- 3.3 A crane lifts a load of 6,5 kN vertically upwards to a height of 10 m.
- 3.3.1 Draw a graph representing the work done by the crane.
Scale: 1 kN = 1 cm and 1 m = 1 cm (3)
- 3.3.2 From the graph calculate the work done. (2)
- [12]**

QUESTION 4

- 4.1 Choose the correct word(s) from those given in brackets. Write only the word(s) next to the question number (4.1.1–4.1.5) in the ANSWER BOOK.
- 4.1.1 Mercury has a (higher/lower) boiling point compared to alcohol.
- 4.1.2 Alcohol has a (higher/lower) freezing point compared to mercury.
- 4.1.3 When a substance changes from a liquid to a solid heat is (added/removed).
- 4.1.4 A (thermocouple/radiation pyrometer) can measure temperatures above 600 °C.
- 4.1.5 Heat is measured in (Joule/°C). (5 x 1) (5)
- 4.2 Draw a neat labelled sketch of a clinical thermometer. (3)
- 4.3 Heat transfer can take place differently in the different phases of matter.
Write the correct transfer method for the following phases:
- 4.3.1 Solid
- 4.3.2 Liquid
- 4.3.3 Gas (3 x 1) (3)
- 4.4 Calculate the quantity of heat energy released by 250 kg of water that is cooled down from 55 °C to 15 °C. The specific heat capacity of water is 4 187 J/kg °C. (2)





- 4.5 A copper pipe in a hot water system is 36 m long at a temperature of 85 °C. The temperature decreases to 25 °C and the length decreases to 35,105 m.
- 4.5.1 Calculate the change in length of the copper pipe.
- 4.5.2 Calculate the change in temperature. (2 x 1) (2)
- 4.6 Consider the following: a hot ball of lead is dropped into a container with cold water. Assume no heat loss.
- 4.6.1 What happened between the two substances?
- 4.6.2 What law has been satisfied?
- 4.6.3 What happened ultimately to the temperature? (3 x 1) (3)
- [18]**

QUESTION 5

- 5.1 Give ONE word/term for each of the following descriptions. Write only the word/term next to the question number (5.1.1–5.1.5) in the ANSWER BOOK.
- 5.1.1 The smallest part of an element.
- 5.1.2 Anything that occupies space and has mass.
- 5.1.3 The smallest part of a chemical compound.
- 5.1.4 The process when a solid turns into a liquid.
- 5.1.5 The process when a gas turns into a liquid. (5 x 1) (5)
- 5.2 Particles are arranged differently in the different phases of matter. Describe the arrangement of particles in the three different phases. (3)
- 5.3 Name the THREE particles of an atom and the charge of each. (3)
- 5.4 What do you understand by the term *ion*? (1)
- [12]**

QUESTION 6

- 6.1 Choose an item from COLUMN B that matches a word in COLUMN A. Write only the letter (A–D) next to the question number (6.1.1–6.1.5) in the ANSWER BOOK.

COLUMN A		COLUMN B	
6.1.1	Battery	A	
6.1.2	Resistor	B	
6.1.3	Ammeter	C	
6.1.4	Galvanometer	D	
6.1.5	Switch	E	

(5 x 1) (5)

- 6.2 Define the following terms:

- 6.2.1 Insulator
6.2.2 Resistance
6.2.3 Potential difference
6.2.4 Joule' s law

(4 x 1) (4)

- 6.3 Two resistors of 125Ω and 230Ω respectively are connected in parallel with a battery of 24 V.

- 6.3.1 Calculate the total resistance of the circuit.
6.3.2 Calculate the total current in the circuit.
6.3.3 Calculate the total power of the circuit.

(3 x 2) (6)

- 6.4 The resistance of a conductor can be influenced by certain factors.

Briefly discuss the way in which these factors will influence the resistance of a conductor under the following headings:

- 6.4.1 Resistivity
6.4.2 Length

(2 x 1) (2)

6.5 Temperature has different influences on different materials.

Under the following headings describe the effect of temperature on the different materials.

6.5.1 Alloys like brass

6.5.2 Insulators like PVC

(2 x 1) (2)

6.6 Draw a neat labelled sketch of the magnetic field lines around a bar magnet. (3)

6.7 Draw a neat labelled sketch of a single stroke electrical bell. (4)

[26]

TOTAL: 100

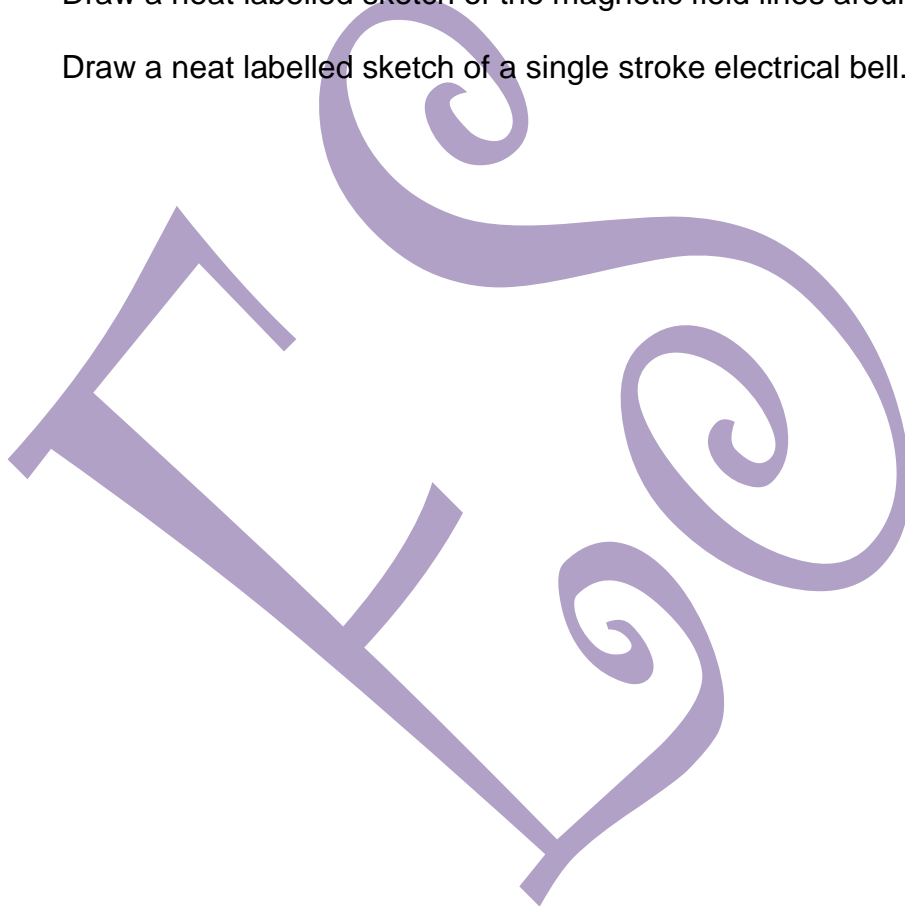

ENGINEERING SCIENCE N1**FORMULA SHEET**

Any applicable formula may also be used.

$$1. \quad v = \frac{s}{t}$$

$$2. \quad F = m.g$$

$$3. \quad DR = \frac{E_{dist.}}{L_{dist.}}$$

$$VV = \frac{M_{afst.}}{L_{afst.}}$$

$$4. \quad MA = \frac{L}{E}$$

$$HV = \frac{L}{M}$$

$$5. \quad VR = \frac{D}{d}$$

$$SV = \frac{D}{d}$$

$$6. \quad \text{MOMENT} = F.s$$

$$7. \quad T = F.R$$

$$8. \quad W = F.S$$

$$9. \quad P = \frac{W}{t}$$

$$10. \quad P = F.v$$

$$11. \quad Q = m.c. \Delta t$$

$$12. \quad L_f = L_o + \Delta L$$

$$13. \quad L_f = L_o - \Delta L$$

$$14. \quad P = V.I$$

$$15. \quad P = I^2.R$$

$$16. \quad P = \frac{V^2}{R}$$

$$17. \quad Q = P.t$$

$$18. \quad I = \frac{V}{R}$$

$$19. \quad R_t = R_1 + R_2 \dots$$

$$20. \quad \frac{1}{R_t} = \frac{1}{R_1} + \frac{1}{R_2} \dots$$



**higher education
& training**

Department:
Higher Education and Training
REPUBLIC OF SOUTH AFRICA

MARKING GUIDELINE

**NATIONAL CERTIFICATE
APRIL EXAMINATION
ENGINEERING SCIENCE N1**

6 APRIL 2016

This marking guideline consists of 12 pages.

- ✓ = 1 mark.
- ✓ = ½ mark.

Calculations:

- 1 mark for substitution and conversion of values.
- 1 mark for answer and unit.
- -½ mark for using the incorrect unit.

QUESTION 1

- | | | |
|-----|-------|---|
| 1.1 | 1.1.1 | C |
| | 1.1.2 | D |
| | 1.1.3 | B |
| | 1.1.4 | A |

(4 x 1) (4)

1.2

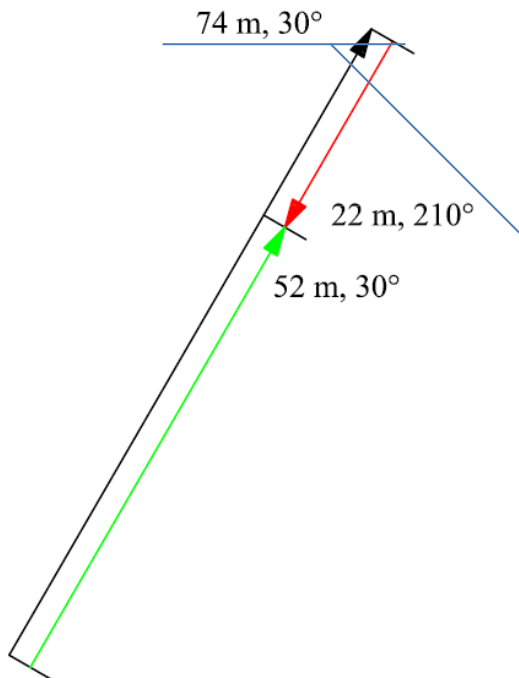

✓✓ Resultant = 52 m, 30° ✓ (2)

1.3 1.3.1

$$v = \frac{s}{t}$$

$$s = v \cdot t$$

$$s = 375 \times \left(\frac{15}{60}\right) \quad \checkmark \checkmark$$

$$s = 93,75 \text{ km}$$

1.3.2

$$v = \frac{s}{t}$$

$$t = \frac{s}{v}$$

$$t = \frac{93,75}{375 \times 25\%} \checkmark \checkmark$$

$$t = \frac{93,75}{468,75}$$

$$t = 0,2 \text{ hours}$$

$$t = 12 \text{ min}$$

(2 x 2) (4)

1.4 1.4.1

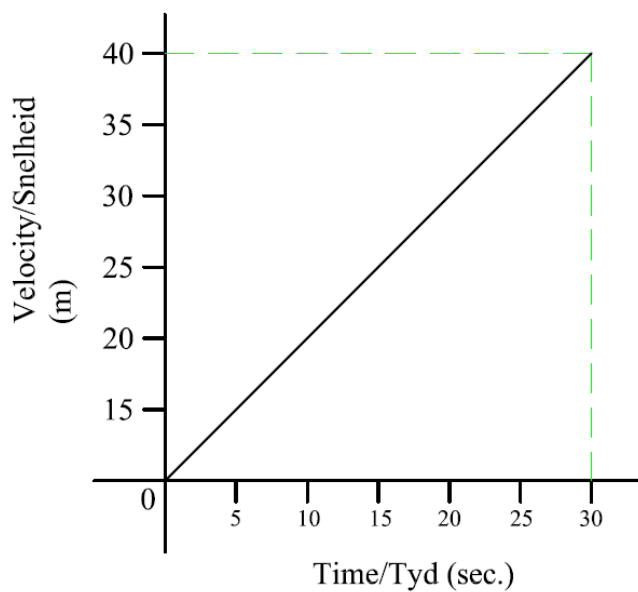

✓✓✓

(3)

1.4.2

$$a = \frac{\Delta v}{t}$$

$$a = \frac{40}{30} \checkmark \checkmark$$

$$a = 1,333 \text{ m.s}^{-2}$$

(2)
[15]

QUESTION 2

- 2.1 2.1.1 False
 2.1.2 False
 2.1.3 True
 2.1.4 True
 2.1.5 False

(5 x 1) (5)

2.2 2.2.1

$$VR = \frac{E_{Dist}}{L_{Dist}}$$
$$E_{Dist} = VR \times L_{Dist} \quad \checkmark \checkmark$$
$$E_{Dist} = 3 \times 3,5$$
$$E_{Dist} = 10,5 \text{ m}$$

2.2.2

$$MA = \frac{L}{E}$$
$$E = \frac{L}{MA} \quad \checkmark \checkmark$$
$$E = \frac{550}{2,5}$$
$$E = 220 \text{ N}$$

(2 x 2) (4)

2.3

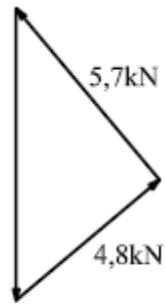
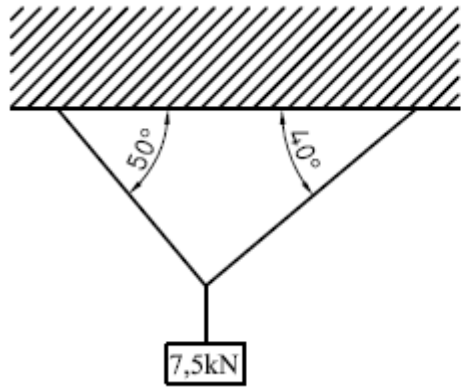

✓✓✓

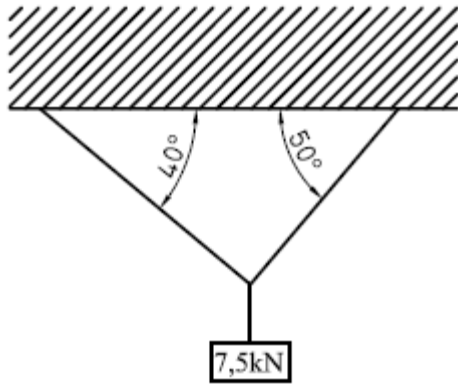

OR

By calculations

Consider both A and B up

	A	B	125N
x	$-A \cos 40^\circ = -0,766A$	$B \cos 50^\circ = 0,643B$	0
Y	$A \sin 40^\circ = 0,643$	$B \sin 50^\circ = 0,766B$	-125

$$\sum x = 0$$

$$-0,766A + 0,643B = 0$$

$$B = 1,191A$$

1

$$\sum y = 0$$

$$0,643A + 0,766B = 7,5$$

2

1 in 2

$$0,643A + 0,766 \times 1,191A = 7,5$$

$$A = 4,823N$$

Therefore

$$B = 1,191 \times 4,823 = 5,744 \text{ kN}$$

✓✓✓

(3)

2.4 $LM = RM$

$$P \times 3 = 125 \times 2$$

$$P = \frac{125 \times 2}{3} \quad \checkmark \checkmark$$

$$P = 83,333 \text{ N}$$

(2)

2.5

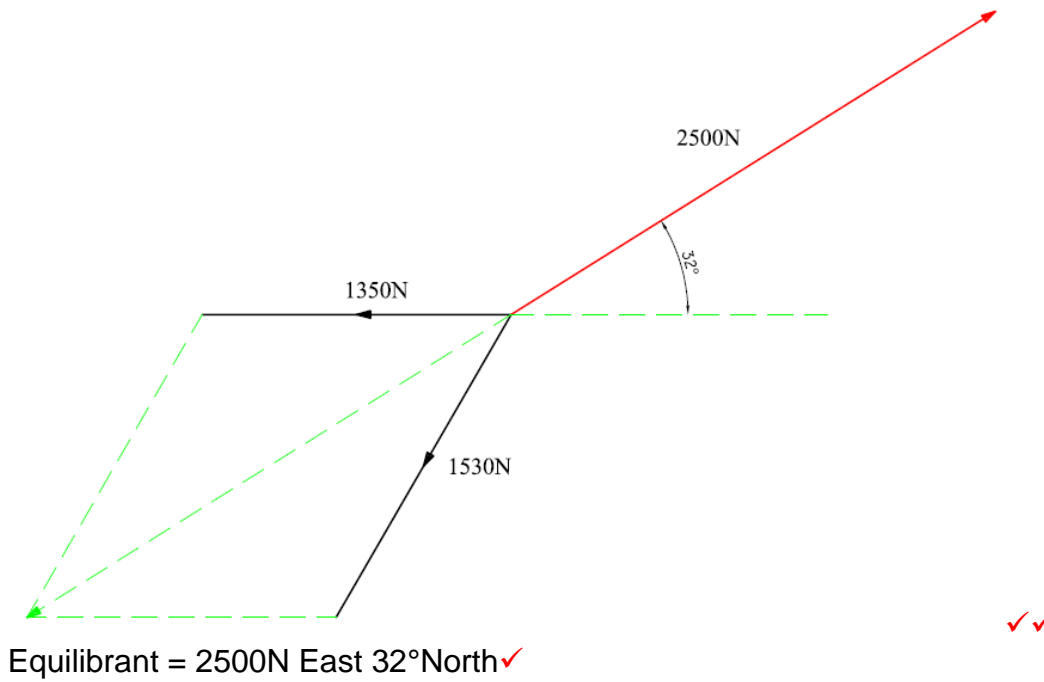

✓✓

OR

By calculations

(3)
[17]

QUESTION 3

- 3.1 3.1.1 B
- 3.1.2 A
- 3.1.3 B
- 3.1.4 A
- 3.1.5 B

(5 x 1) (5)

- 3.2 $W = F \times s$
- $W = 525 \times 200$
- $W = 105\,000$ ✓✓
- $W = 105\,kJ$

(2)

3.3 3.3.1

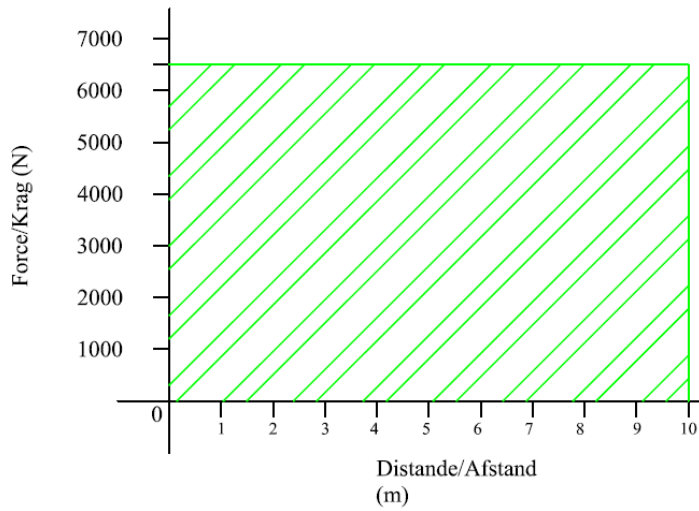

✓✓✓

(3)

3.3.2

$$W = F \times s$$

$$W = 6\,500 \times 10$$

$$W = 65\,000 \text{ J}$$

$$W = 65 \text{ kJ}$$

✓✓

(2)

[12]

QUESTION 4

- 4.1 4.1.1 Higher
- 4.1.2 Lower
- 4.1.3 Removed
- 4.1.4 Radiation pyrometer
- 4.1.5 Joule

(5 x 1)

(5)

4.2

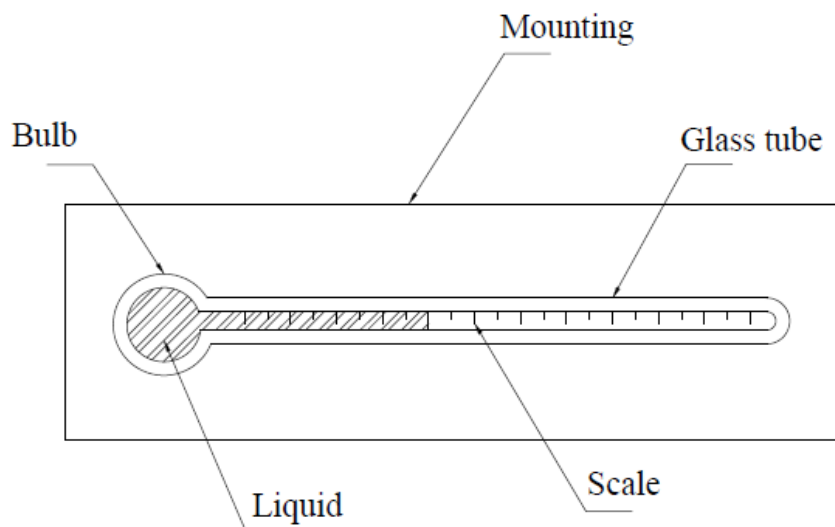

✓✓✓

(3)

- 4.3 4.3.1 Conduction
 4.3.2 Convection
 4.3.3 Convection/radiation

(3 x 1) (3)
- 4.4 $Q = m \times c \times \Delta t$
 $Q = 250 \times 4187 \times (55 - 15)$ ✓✓
 $Q = 418700 \text{ 00 J}$
 $Q = 41,87 \text{ MJ}$

(2)
- 4.5 4.5.1 $\Delta l = l_o - l_f$
 $\Delta l = 36 - 35,105$ ✓
 $\Delta l = 0,895m$
 $\Delta l = 895 \text{ mm}$

 4.5.2 $\Delta t = t_o - t_f$
 $\Delta t = 85 - 25$ ✓
 $\Delta t = 60 \text{ }^\circ\text{C}$

(2 x 1) (2)
- 4.6 4.6.1 Heat is transferred between the lead and water.
 4.6.2 The law of conservation of energy.
 4.6.3 The temperature of both materials is the same.

(3 x 1) (3)
[18]

QUESTION 5

- 5.1 5.1.1 Atom
 5.1.2 Matter
 5.1.3 Molecule
 5.1.4 Melting
 5.1.5 Condensation

(5 x 1) (5)
- 5.2 Gas: particles far from each other
 Liquid: particles not far from each other
 Solid: particles close to each other

(3)
- 5.3 Electron – negative
 Neutrons – neutral
 Proton – positive

(3)

- 5.4 When an atom has gained or lost an electron. ✓ (1)
[12]

QUESTION 6

- 6.1 6.1.1 C
6.1.2 D
6.1.3 A
6.1.4 E
6.1.5 B
(5 x 1) (5)

- 6.2 6.2.1 Insulator – is a material that prevents the flow of electrical current.
6.2.2 Resistance – is a material that resists the flow of electrical current.
6.2.3 Potential difference – is the electrical pressure required to overcome the resistance in order for a current to flow.
6.2.4 Joule's Law – the quantity of heat generated by an electrical current is directly proportional to ????. Is something not missing here?
(4 x 1) (4)

6.3 6.3.1
$$\frac{1}{R_t} = \frac{1}{R_1} + \frac{1}{R_2}$$

$$\frac{1}{R_t} = \frac{1}{125} + \frac{1}{230} \checkmark \checkmark$$

$$\underline{\underline{R_t = 80,986\Omega}}$$

6.3.2
$$I = \frac{V}{R}$$

$$I = \frac{24}{80,986} \checkmark \checkmark$$

$$I = 0,296A$$

$$\underline{\underline{I = 296mA}}$$

6.3.3
$$P = V \times I$$

$$P = I^2 R$$

$$P = \frac{V^2}{R}$$

$$P = 24 \times 0,296 \text{ OR } P = 0,296^2 \times 80,986 \text{ OR } P = \frac{24^2}{80,986} \checkmark \checkmark$$

$$\underline{\underline{P = 7,104W}}$$

$$\underline{\underline{P = 7,096W}}$$

$$\underline{\underline{P = 7,112W}}$$

(3 x 2) (6)

- 6.4 6.4.1 Resistivity – Different metals have different resistances.
- 6.4.2 Length – The longer the conductor, the higher the resistance. (2 x 1) (2)
- 6.5 6.5.1 Alloys – no change in resistance. ✓
- 6.5.2 Insulators – The resistance decreases with the rise in temperature. ✓ (2 x 1) (2)

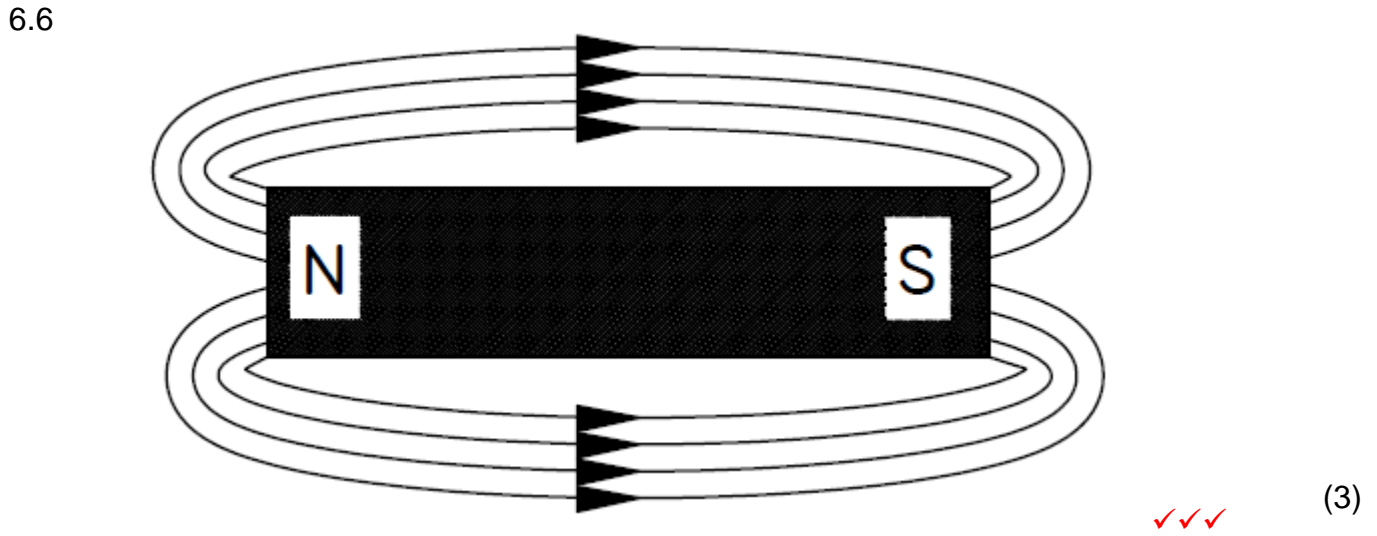

6.7

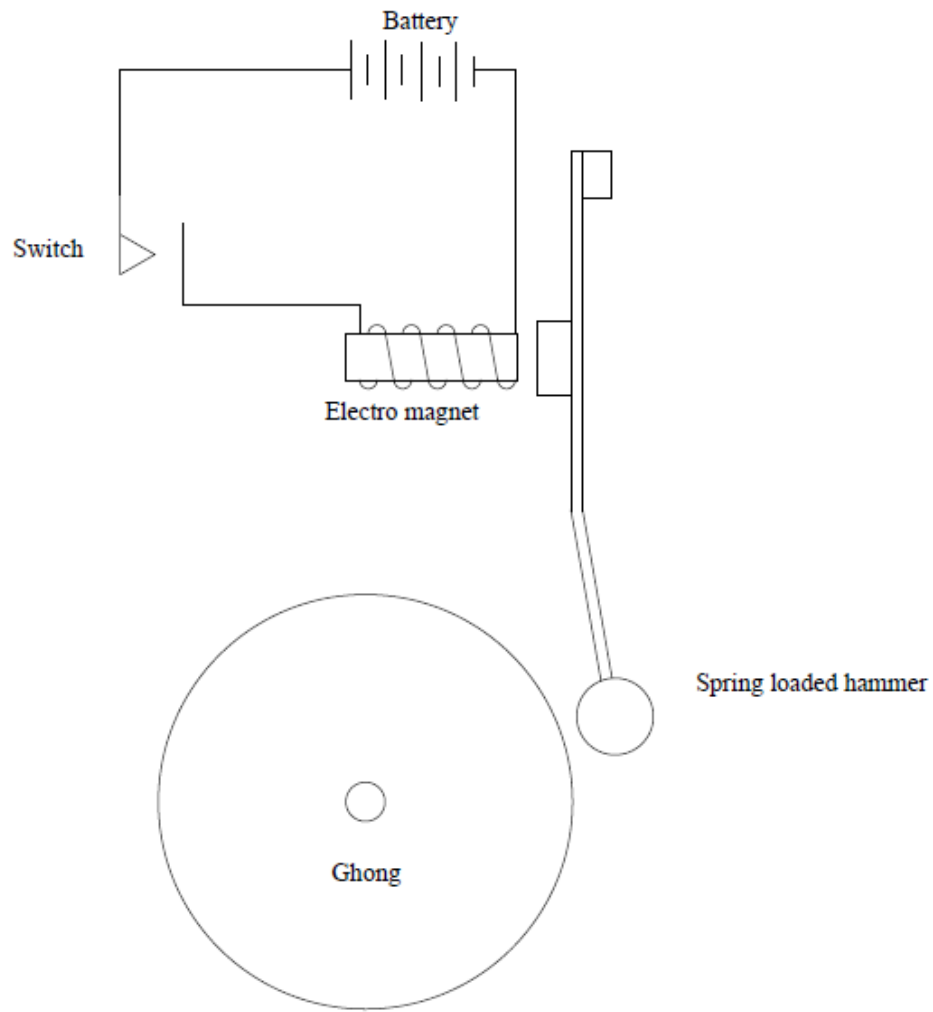

✓✓✓✓ (4)
[26]

TOTAL: 100



PAST EXAM PAPERS AND MEMOS
Get All Your Engineering Past Exam Papers With Answers

Website: www.previouspapers.co.za

Email: info@previouspapers.co.za

CELL: 073 770 3028

THANK YOU FOR
DOWNLOADING
PAST EXAM PAPER &
MEMO FOR N1

IF YOU NEED MORE PAPERS WE SELL THEM FOR R300

VISIT OUR WEBSITE AT WWW.PREVIOUSPAPERS.CO.ZA

OR SEND US AN EMAIL AT INFO@PREVIOUSPAPERS.CO.ZA AND

WE WILL GLADLY HELP YOU.