

**PATRIOT<sup>®</sup>**

***Exhaust Products***

***A PerTronix Performance Brand***



***2014-2015***

# **PATRIOT**<sup>®</sup>

**Exhaust Products**

Patriot Exhaust continues to offer the best value for the dollar of any header brand in the industry. Known for years as the primary exhaust supplier to the Street Rod, Custom Car and Muscle Car enthusiast, our 2014-15 Catalog will not disappoint you with many new products and updates.

**NEW** this year, all Patriot headers and side tubes are now available finished with an affordable Hi-Temp Black Coating. Check out catalog listings for more application information.

We are excited to be a Pertronix Performance Brand and look forward to continuing a 40 plus year tradition of supplying quality products and excellent customer service.



The Pertronix Performance Brands sponsored Hairston Motorsports and Racing Pro-Mod GTO is the Quickest quarter mile Small Block door car in history running 5.91 seconds and the Fastest Small Block in drag racing history Period 252.38 MPH!



**Introduction**  
Header facts ..... 2  
How to use this catalog..... 3

**Headers**  
Tight Tuck Headers..... 4-5  
Lakester Headers ..... 6-7  
Roadster Sprint Car Headers ..... 8-9  
Street Rod Headers ..... 10-11  
Engine Swap Headers ..... 12  
Passenger Car Headers..... 13-17  
Truck Headers..... 18-19  
Classic Import Headers ..... 20  
Racing Headers & Weld-Up Kits ..... 20-21

**Side Exhaust**  
Shielded Side Pipes & Side Tube Turnouts ..... 22  
Lake Pipes..... 23

**Mufflers** ..... 24-25

**Exhaust Tips** ..... 26

**Components and Accessories**  
Exhaust Accessories ..... 27-28  
Formed Collectors & Flanges ..... 29  
Header Flange Kits..... 30  
Gaskets ..... 31  
J Bends, U Bends & Speciality Bends..... 32-34

**Picture Gallery** ..... 35-41

**Part Number Index** ..... 42-43

**Footnote Summary**..... 44

**Warranty** ..... Inside back cover



## **HEADER FACTS**

### **What finish is applied to a Patriot headers?**

Most Patriot headers are available in raw steel for individual customizing. However, the preferred finish continues to be our Metallic Ceramic Thermal Barrier Coating (MCTBC). MCTBC protects and extends the life of headers by creating a thermal barrier which significantly lowers under hood temperatures and protects the substrate metal from thermal fatigue. After MCTBC is applied, it is polished with a vibratory finishing process that produces a high luster aluminum appearance. The polishing process compresses and activates the coating, creating a surface which is harder and 60% more corrosion resistant than an unpolished surface. This coating is easy to maintain and will last for years under normal operating conditions.

NEW for this year is our Hi-Temp Black Coating available on Patriot headers and side tubes. An affordably priced alternative to our MCTBC, our Hi-Temp Black finish provides good corrosion and heat protection when compared to many of the "cheaper" header finishes being applied by our competitors.

Check our catalog listing for complete product information.

### **What should I do if I encounter an installation problem with my header?**

Header installation for the most part can be accomplished with simple hand tools, a floor jack and jack stands. Some applications can be very time consuming due to limited space in the engine compartment. Should you encounter a fitment problem do not attempt to modify or alter the header in any way or your warranty will become void. Headers returned without prior written authorization will be refused. Read our complete warranty policy on the last page of this catalog.

### **Do all Patriot headers have the same basic design?**

No, absolutely not. Patriot headers are designed for specific applications. The type of header design will change depending on the intended vehicle usage and emissions requirements. Patriot headers for conventional V-8 applications utilize several types of header designs:

#### **Long Tube Headers**

Long Tube Headers are typically used for higher RPM horsepower, but can also increase the mid range torque in applications where there is room to fit a long tube design.



#### **Roadster Headers**

Classic or the high performance Sprint style Roadster headers are typically used in T buckets and Hi-Boy Street rods.



#### **Mid Length Headers**

Mid Length or "clippster" Headers provide improved ground clearance for popular muscle cars and street rods.



#### **Lakester Headers**

Lakester headers capture the look and performance reminiscent of the Bonneville and Dry Lakes racers. Traditional Lakesters are used without any additional exhaust system, while Classic Lakesters have provision for an under car exhaust system.



#### **Tight Tuck Headers**

Tight Tuck Headers are the best solution for narrow frame rail street rods.



#### **Fenderwell Headers**

Fenderwell headers provide the ultimate performance for street rodders with performance engines. These "up and over" headers create an awesome gasser look.



#### **Weld Up Kits**

Weld-up header kits work great when a specific fit header or style is not available. Kits include mandrel bent tubes, flanges and collectors.





**HOW TO USE THIS CATALOG**

Patriot header application information is grouped into sections by product type. The street rod, passenger car, 2WD & 4WD truck and engine swap headers are listed in their respective sections. Within each section applications are listed by vehicle make and model when applicable, then engine family and year(s). Applications may have associated footnotes containing critical product and fitment information. A footnote key can be found at the bottom of most odd numbered pages. Please make sure that you thoroughly read the footnotes prior to ordering. The following list defines some of the abbreviations and acronyms that are found in this catalog:

The following list defines some of the abbreviations and acronyms that are found in this catalog:

---

A/C..... Air conditioning	FLR..... Floor	REC ..... Rectangle Port
AUTO..... Automatic transmission	OVL ..... Oval Port	SAP ..... Same As Port
COL..... Column shift	P/B ..... Power Brakes	STD ..... Standard Transmission
COLL..... Collector	P/S ..... Power Steering	SQ ..... Square Port
DIA ..... Diameter	RD ..... Round Port	

**EMISSION CODES**

Patriot uses a voluntary product identification program whereby all emission-sensitive products can be identified by placing numbered labels in product packaging and listing corresponding numeric codes next to each part number. The corresponding numbers and explanations are as follows:



This Product has been granted a California Air Resources Board (CARB) “E.O.” (Executive Order) Exemption, or is considered a Direct Replacement or Consolidated Replacement part. It is 50 State Legal when installed on the appropriate vehicle per the Manufacturer Application guide and Installation Instructions.



This product is Legal for use on 1974 and older non catalyst equipped vehicles and is considered a “replacement part” per California Air Resources Board regulations, as long as ALL emissions sensitive components are retained, including A.I.R., EGR, Heat Risers etc. Failure to retain any of these components, or use on any 1975 or newer catalytic converter equipped car would render this product Illegal for Street or Off Highway Use in California, or in states that have adopted California Emissions regulations and may only be used for Closed Course Competition.



This product is Not legal for Street or Off Highway use in California or in states that have adopted California Emissions Regulations and is only intended for Closed Course Competition use, except 1965 and Older US manufactured California Certified vehicles, 1967 or older US manufactured Federally Certified vehicles, or 1967 and older Foreign manufactured vehicles which may have any aftermarket add-on or modified part installed as long as the vehicle can still meet the tailpipe emission standards for the year of the vehicle and retain any original or retrofit crankcase control (PCV) devices and NOx device required for the year of the vehicle.



## TIGHT TUCK HEADERS



### TIGHT TUCK HEADERS

Tight Tuck headers are the solution to many problems associated with engine swaps in modern street rods. Tight Tucks fit in the tightest of engine compartments and clear most stock motor mounts. Most headers are manufactured from durable 16-gauge tubing and comes complete with gaskets, header bolts and collector reducers.

ENGINE	RAW STEEL	HI-TEMP BLACK COATING	METALLIC CERAMIC COATING	CHROME	STAINLESS STEEL	EMISSION CODE	FOOTNOTES	TUBE SIZE	COLLECTOR SIZE	PORT SHAPE
<b>BUICK NAILHEAD</b>										
401-425	H8500	H8500-B	H8500-1	-----	-----	⬡	11	1 5/8"	2 1/2"	SAP
<b>CADILLAC</b>										
425, 472, 500	H8064	H8064-B	H8064-1	-----	-----	⬡	11	1 7/8"	3"	SAP
<b>CHEVROLET</b>										
4.3L V6	H8067	H8067-B	H8067-1	-----	-----	⬡	11	1 1/2"	2 1/2"	RD
265-400	H8019	H8019-B	H8019-1	-----	-----	⬡	11, 12, 15, 16, 17, 24, 36	1 5/8"	2 1/2"	OVL
265-400	H8027	H8027-B	H8027-1	H8028	-----	⬡	1, 11, 15, 16, 20, 24	1 5/8"	2 1/2"	RD
265-400	H8037	H8037-B	H8037-1	-----	-----	⬡	11, 15, 16, 17, 24	1 5/8"	2 1/2"	RD
265-400	H8052	H8052-B	H8052-1	-----	H8053	⬡	11, 15, 17, 24, 36, 81	1 5/8"	2 1/2"	OVL
265-400	H8065	H8065-B	H8065-1	-----	-----	⬡	11, 17, 36, 217	1 5/8"	2 1/2"	OVL
LS1-LS6	H8014	H8014-B	H8014-1	-----	-----	⬡	11, 16, 86, 107	1 5/8"	2 1/2"	RD
<b>NEW</b> LS1-LS6	H8006	H8006-B	H8006-1	-----	-----	⬡	11, 86, 107	1 3/4"	2 1/2"	RD
LS1-LS6	H8086	H8086-B	H8086-1	-----	-----	⬡	11, 34, 86	1 3/4"	2 1/2"	RD
<b>NEW</b> LS E-ROD	H8080	H8080-B	H8080-1	-----	-----	⬡	16, 121, 182	1 3/4"	2 1/2"	RD
348-409	H8066	H8066-B	H8066-1	-----	-----	⬡	11	1 3/4"	2 1/2"	SAP
396-502	H8029	H8029-B	H8029-1	-----	-----	⬡	11, 15, 16, 20, 24, 37	1 3/4"	2 1/2"	SAP
<b>FORD</b>										
FLATHEAD	-----	H8090	H8090-1	-----	-----	⬡	11, 16	1 3/4"	2 1/2"	RD
260-351W	H8427	H8427-B	H8427-1	H8428	-----	⬡	6, 7, 11, 16, 20, 55, 201	1 5/8"	2 1/2"	OVL
260-351W	H8482	H8482-B	H8482-1	-----	-----	⬡	11, 16, 47, 217, 228	1 5/8"	2 1/2"	OVL
429-460	H8437	H8437-B	H8437-1	-----	-----	⬡	11	1 3/4"	3"	SAP
5.0L COYOTE	H8483	H8483-B	H8483-1	-----	-----	⬡	11, 34, 85	1 3/4"	2 1/2"	SAP
<b>MOPAR</b>										
318-360	H8205	H8205-B	H8205-1	-----	-----	⬡	11, 15	1 5/8"	2 1/2"	SAP
331-392 HEMI	H8204	H8204-B	H8204-1	-----	-----	⬡	11	2"	3"	SAP
5.7 / 6.1L HEMI	H8201	H8201-B	H8201-1	-----	-----	⬡	11, 86	1 3/4"	2 1/2"	SAP

## HEADER DIMENSIONS

PART NO.	DIMENSION A LEFT	DIMENSION A RIGHT	DIMENSION B LEFT	DIMENSION B RIGHT
H8006	3.5	3.5	12	12
H8014, H8064	4"	4"	11"	11"
H8019, H8500	4 1/2"	4 1/2"	10"	10"
H8027, H8028	4"	4"	10"	10"
H8029	4 1/2"	4 1/2"	12 1/4"	12 1/4"
H8037	4"	4"	12 1/2"	12 1/2"
H8052, H8053	4"	4"	6"	6"
H8065	3 1/2"	3 1/2"	11"	11"
H8066	2"	2"	8 1/2"	8 1/2"
H8067	3 1/2"	4"	5 1/4"	7 1/2"
H8080	4 1/2"	4"	8"	8 1/2"
H8090	4"	4"	9"	9"
H8204	3"	3"	10"	10"
H8205	3"	3"	10 1/2"	10 1/2"
H8427, H8428	4 1/2"	4 1/2"	11"	11"
H8437	5"	5"	12"	12"
H8482	2"	2"	12"	17"

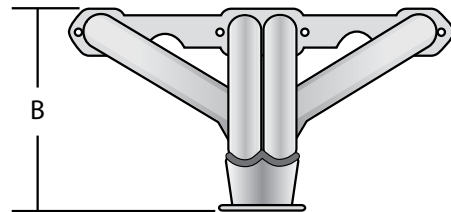



## TIGHT TUCK HEADERS



**H8014-1**



**H8019-1**



**H8027-1**



**H8029-1**



**H8037-1**



**H8052-1**



**H8064-1**



**H8065-1**



**H8066-1**



**H8067-1**



**H8090-1**



**H8204-1**



**H8205-1**



**H8427-1**



**H8437-1**



**H8482-1**



**H8483-1**



**H8500-1**

### FOOTNOTES

- |  |   |   |
|--|---|---|
| <p>1 Does not fit angle plug heads</p> <p>6 Due to variations on motor mounts, we recommend Anchor mounts (# 270-2221 left and # 270-2220 right) or equivalent. Left mount may need to be ground by 1/4" to provide clearance for collector.</p> <p>7 157 tooth flywheel use Ford Racing Mini Starter #M-11000-B51 or equivalent 167 tooth flywheel use Ford Racing Mini Starter #M-11000-MT164 or equivalent</p> <p>11 Universal block hugger design</p> <p>12 Dome type reducer kit available separately part # H7247</p> <p>15 Can be used with most oil filter system or transmission and starter combination</p> <p>16 Tucks very close to engine</p> | <p>17 Fits most angle plug heads</p> <p>20 Chrome headers are polished before and after assembly for show quality appearance</p> <p>24 Tight tuck headers do not fit 55-57 Chevys, Camaros or other modern vehicles which have a crossmember below the engine's center two exhaust ports. See catalog pages 13-17 for specific fit applications</p> <p>34 Rear Exit</p> <p>36 Fits D-Port cylinder heads including Z24 crate engines</p> <p>37 Fits standard deck big blocks only</p> <p>47 Fits with stock, Mustang and Vega steering</p> <p>55 Fits GT40 "P" head</p> | <p>81 This header is shorter than other tight tucks allowing more room for steering components.</p> <p>85 Equipped with O2 Sensor Bungs</p> <p>86 Weld on oxygen sensor bungs are provided with the collector reducer kit.</p> <p>107 LS1/LS6 engines require the use of a LS1 oil pan for proper header fit.</p> <p>121 50-State Legal C.A.R.B. E.O. #D-57-29, D-57-31</p> <p>182 Header bolts directly to E-Rod catalytic converters</p> <p>201 Designed to fit engines with forward sump oil pans</p> <p>217 Flat collector design for maximum frame clearance</p> <p>228 Will not fit GT40 "P" head</p> |
|--|---|---|



## LAKESTER HEADERS

### LAKESTER



### TRADITIONAL LAKESTER

### LAKESTER HEADERS

Give your rod a nostalgic look with a Lakester style header. Our classic lakester design allows for hookup to an under chassis exhaust system, but by removing the provided block-off plates you can easily uncork your headers.

The traditional Lakester headers capture the look and performance reminiscent of the Bonneville and Dry Lakes racers. Traditional Lakester headers are designed for use with no other exhaust system for that open header style and sound or use our muffler inserts on page 7 for a more mild sound.

ENGINE	HI-TEMP BLACK COATING	METALLIC CERAMIC COATING	CHROME	EMISSION CODE	FOOTNOTES	TUBE SIZE	COLLECTOR SIZE	PORT SHAPE
<b>BUICK NAILHEAD</b>								
<b>LAKESTER</b>								
401-425	H8503	H8503-1	-----	Ⓢ	172	1 5/8"	3 1/2"	SAP
<b>TRADITIONAL LAKESTER</b>								
401-425	H8501	H8501-1	-----	Ⓢ	10	1 5/8"	3 1/2"	SAP
<b>CHEVROLET</b>								
<b>LAKESTER</b>								
265-400	H8040	H8040-1	-----	Ⓢ	17, 20, 36, 172	1 5/8"	3 1/2"	OVL
348-409	H8074	H8074-1	-----	Ⓢ	172	1 7/8"	3 1/2"	SAP
396-502	-----	-----	H8043	Ⓢ	20, 172	1 7/8"	4"	SAP
<b>TRADITIONAL LAKESTER</b>								
265-400	H8084	H8084-1	-----	Ⓢ	10, 17, 36	1 5/8"	3 1/2"	OVL
<b>FORD</b>								
<b>LAKESTER</b>								
FLATHEAD	H8474	H8474-1	-----	Ⓢ	172	1 3/4"	3 1/2"	RD
260-351W	H8431	H8431-1	-----	Ⓢ	20, 55, 172	1 5/8"	3 1/2"	OVL
<b>TRADITIONAL LAKESTER</b>								
FLATHEAD	H8472	H8472-1	-----	Ⓢ	10	1 3/4"	3 1/2"	RD
260-351W	H8471	H8471-1	-----	Ⓢ	10, 55	1 5/8"	3 1/2"	OVL
<b>MOPAR</b>								
<b>LAKESTER</b>								
331-392 HEMI	H8208	H8208-1	-----	Ⓢ	172	1 7/8"	3 1/2"	RD
<b>TRADITIONAL LAKESTER</b>								
331-392 HEMI	H8210	H8210-1	-----	Ⓢ	10	1 7/8"	3 1/2"	RD

## LAKESTER HEADER DIMENSIONS

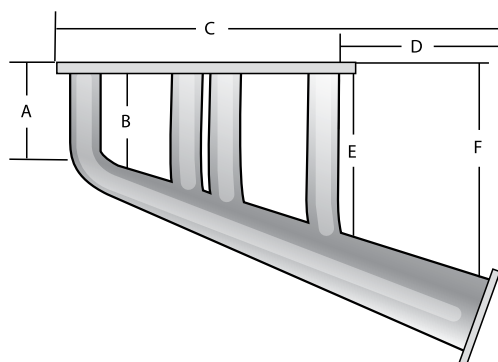

PART NO.	DIM. A	DIM. B	DIM. C	DIM. D	DIM. E	DIM. F
H8040	6 1/2"	4 1/4"	28 1/2"	11"	8 1/2"	12"
H8043	4 1/2"	2 1/2"	27"	12 1/2"	6 1/2"	9"
H8074	3"	5 3/4"	28"	8 3/4"	9 1/2"	11 1/2"
H8084	6 1/2"	4 1/4"	28 1/2"	11"	8 1/2"	12"
H8208, 10	7"	5 3/4"	34"	14"	8"	9"
H8431	7 1/2"	6"	27"	17 1/2"	10 1/4"	11 3/4"
H8471	7 1/2"	6"	27"	17 1/2"	10 1/4"	11 3/4"
H8472, 74	5"	6"	34"	16"	9 1/2"	13"
H8501, 03	7"	5 1/2"	27"	8"	9"	10"





**LAKESTER HEADERS**



**LAKESTER WELD-UP KITS**

Our weld-up header kits work great for street rodders and racers who want to build custom headers to give their rods a unique look. Lakester style header kits featuring 16 gauge mild steel tubing and specially designed tapered collector cones. Each kit includes all the necessary tubes, flanges, gaskets and hardware.

ENGINE	PART NO.	FOOTNOTES	TUBE SIZE	COLLECTOR SIZE	PORT SHAPE
<b>BUICK NAILHEAD</b>					
401-425	H8504	41, 172	1 5/8"	3 1/2"	SAP
<b>CHEVROLET</b>					
265-400	H8001	41, 172	1 5/8"	3 1/2"	OVL
265-400	H8002	41, 172	1 5/8"	4"	OVL
348-409	H8075	41, 172	1 7/8"	3 1/2"	SAP
396-502	H8003	41, 172	1 7/8"	3 1/2"	SAP
396-502	H8004	41, 172	1 7/8"	4"	SAP
<b>FORD</b>					
FLATHEAD	H8475	41, 172	1 3/4"	3 1/2"	RD
260-351W	H8414	41, 55, 172	1 5/8"	3 1/2"	OVL
<b>MOPAR</b>					
331-392 HEMI	H8209	41, 172	1 7/8"	3 1/2"	RD

**LAKESTER TURNOUTS KITS**

Add the finishing touch to lakester headers with one of our turn out kits. Lakester turnouts include gaskets and hardware for simple installation. Traditional lakester turnouts are designed with an inner centric ring for precise fit and near seamless appearance. Available black or metallic ceramic coated.

**TRADITIONAL LAKESTER MUFFLER**

Tame the bark of your traditional lakesters with this muffler insert. Made to slip perfectly into the collector of our traditional lakesters and constructed from heavy duty six-sided louvered core and wrapped with hi-temp packing for a longer life.

DESCRIPTION	HI-TEMP BLACK COATING	METALLIC CERAMIC COATING	COLL DIA.	UNIT OF MEASURE
<b>TRADITIONAL LAKESTER TURNOUTS</b>				
Seamless Turnout	H3811	H3811-1	3 1/2"	pair
<b>CLASSIC LAKESTER TURNOUTS</b>				
3 1/2" Bolt on Turnout	H1145	H1145-1	3 1/2"	pair
4" Bolt on Turnout	H1146	H1146-1	4"	pair



**FOOTNOTES**

10	Outside frame exit	36	Fits D-Port cylinder heads including ZZ4 crate engines	55	Fits GT40 "P" head
17	Fits most angle plug heads	41	Kit includes header flanges, collector flanges, block-off plates, four exhaust hookup flanges, pre-bent header tubes and two collector cones	172	Over frame design with outside exit and provision for exhaust system hookup (lakester style)
20	Chrome headers are polished before and after assembly for show quality appearance				



## ROADSTER / SPRINT CAR HEADERS

### ROADSTER AND SPRINT CAR HEADERS

Roadster "Fad T" and '32 Hi-Boy headers have set the industry standard for style, quality and performance. Choose between the Classic or the high performance Sprint style for small and big block Chevy and small block Ford engines. Match these headers with our turnouts and integral mufflers for a complete exhaust system. All chrome headers are polished before and after assembly to assure ultimate chrome quality 360° around all pipes.



ENGINES	RAW STEEL	HI-TEMP BLACK COATING	METALLIC CERAMIC COATING	CHROME	EMISSION CODES	FOOTNOTES	TUBE SIZE	COLLECTOR SIZE	PORT SHAPE
<b>'32 HI-BOY</b>									
<b>CHEVROLET ENGINES</b>									
265-400	H8071	H8071-B	H8071-1	H8072	⬡	10, 15, 17, 20	1 5/8"	3 1/2"	RD
<b>CLASSIC STYLE FOR T-BUCKETS</b>									
<b>CHEVROLET ENGINES</b>									
265-400	H8061	H8061-B	H8061-1	H8060	⬡	10, 15, 17, 20	1 5/8"	3 1/2"	RD
<b>FORD ENGINES</b>									
260-351W	H8467	H8467-B	H8467-1	H8468	⬡	10, 20, 55	1 5/8"	3 1/2"	OVL
<b>SPRINT CAR STYLE FOR T-BUCKETS</b>									
<b>CHEVROLET ENGINES</b>									
265-400	H8069	H8069-B	H8069-1	H8070	⬡	10, 15, 17, 20	1 5/8"	3 1/2"	RD
396-502	H8031	H8031-B	H8031-1	H8032	⬡	10, 15, 20	1 7/8"	3 1/2"	SAP
<b>FORD ENGINES</b>									
260-351W	H8469	H8469-B	H8469-1	H8470	⬡	10, 20, 55	1 5/8"	3 1/2"	OVL

### HEADER DIMENSIONS

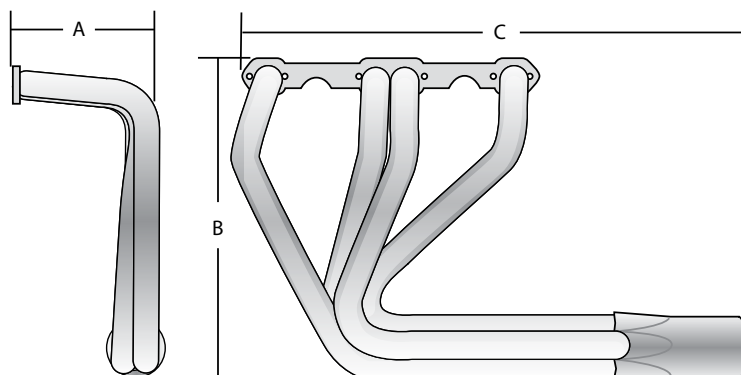

PART NO.	DIMENSION A		DIMENSION B		DIMENSION C	
	LEFT	RIGHT	LEFT	RIGHT	LEFT	RIGHT
H8031	11 1/2"	11 1/2"	14"	14"	34"	32"
H8061	15 1/2"	15 1/2"	12"	12"	37"	37"
H8069	14 1/2"	14 1/2"	13 1/2"	13 1/2"	28 1/2"	28 1/2"
H8071	14 3/4"	14 3/4"	13 3/4"	13 3/4"	30"	30"
H8467	13 1/2"	14"	12"	12"	35"	35"
H8469	15"	15"	14"	14"	28"	28"



**ROADSTER / SPRINT CAR HEADERS**



**SPRINT STYLE WELD-UP KITS**

Sprint style header kits work for outside frame street rod applications, sprint cars, and front strut type drag cars. Sprint style kits come with 8 mandrel bent one piece primaries, 2 flanges, formed collectors, gaskets and bolts.

ENGINE	PART NO.	FOOTNOTES	TUBE DIAMETER	COLLECTOR DIAMETER
<b>CHEVROLET</b>				
265-400	H8009	8, 10	1 1/2"	3"
265-400	H8007	8, 10	1 5/8"	3"
265-400	H8010	8, 10	1 5/8"	3 1/2"
265-400	H8011	8, 10	1 3/4"	3"
265-400	H8016	8, 10, 74	1 3/4"	3 1/2"
265-400	H8015	8, 10, 74	1 7/8"	3 1/2"
396-502	H8005	8, 10	2"	3 1/2"
<b>FORD</b>				
260-351W	H8410	8, 10, 55	1 5/8"	3 1/2"

**SHIELDED SIDE TUBE TURNOUT**

This shielded turnout features a classic slotted one-piece shield that will give your rod a great custom look and provide burn protection when exiting the car. Its built-in six sided louvered muffler provides excellent sound control without robbing horsepower. Large 3 1/2" diameter inlet make this turnout the perfect mate to any of our roadster headers.



PART NO.	INLET DIAMETER	CASE DIAMETER	LENGTH
<b>SHIELDED SIDE TUBE TURNOUT</b>			
H3824	3 1/2"	3 1/2"	26"

**SIDE TUBE TURNOUTS**

Side tube turnouts are designed primarily for roadster style headers. Each turnout is constructed from 3 1/2" tube and available with or without built-in six sided louvered mufflers. Turnouts provide the perfect finishing touch to many custom exhaust applications.



RAW STEEL	HI-TEMP BLACK COATING	METALLIC CERAMIC COATING	CHROME	INLET DIAMETER	LENGTH
<b>SIDE TUBE TURNOUTS WITHOUT MUFFLER</b>					
H3817	H3817-B	H3817-1	H3816	3 1/2"	20"
H3819	H3819-B	H3819-1	H3820	3 1/2"	26"
<b>SIDE TUBE TURNOUTS WITH MUFFLER</b>					
H3812	H3812-B	H3812-1	H3818	3 1/2"	20"
H3821	H3821-B	H3821-1	H3822	3 1/2"	26"

**FOOTNOTES**

- 8 Kits consist of 8 mandrel bent header tubes, flange kit and formed collectors
- 10 Outside frame exit
- 15 Can be used with most oil filter system or transmission and starter combination
- 17 Fits most angle plug heads
- 20 Chrome headers are polished before and after assembly for show quality appearance
- 55 Fits GT40 "P" head
- 74 Fits Brodix spread port cylinder heads



### STREET ROD HEADERS

#### STREET ROD HEADERS

Patriot Street Rod Headers are the solution when a universal Tight Tuck won't fit, or when you want more power. Street Rod Headers are available in Mid Length, Long Tube, and Fenderwell designs. Mid Length Headers offer greater performance over Tight Tucks yet have excellent ground clearance on lowered applications. Long Tube Headers are the ultimate performance header with longer primary tubes for maximum torque and horsepower. Fenderwell Headers offer the same performance benefits in an over the chassis exit design for more steering and engine compartment room and that gasser look. Applications for 1920's through 1950's Ford and Chevy engine and frame combinations, plus popular front frame clip swaps.



YEARS	ENGINES	RAW STEEL	HI-TEMP BLACK COATING	METALLIC CERAMIC COATING	EMISSION CODES	FOOTNOTES	TRANS AUTO	TRANS STD	TUBE SIZE	COLL SIZE	PORT SHAPE
<b>CHEVROLET / GMC ENGINES</b>											
<b>STREET RODS WITH FORD CHASSIS</b>											
<b>LONG TUBE HEADERS</b>											
28-34	265-400	H8017	H8017-B	H8017-1	⬡	15, 17, 45, 46	Y	Y	1 1/2"	3"	RD
28-48	265-400	H8018	H8018-B	H8018-1	⬡	16, 17, 19, 36, 45, 46	Y	Y	1 1/2"	3"	RD
28-48	265-400	H8039	H8039-B	H8039-1	⬡	16, 17, 19, 36, 45, 46	Y	Y	1 5/8"	3"	REC
<b>FENDERWELL HEADERS</b>											
28-48	265-400	H8089	H8089-B	H8089-1	⬡	17, 36, 172	Y	Y	1 3/4"	3"	OVL
<b>FAT FENDERED STREET RODS (MOST CHASSIS)</b>											
<b>FENDERWELL HEADERS</b>											
35-48	265-400	H8033	H8033-B	H8033-1	⬡	4, 10, 15, 17, 19	Y	Y	1 5/8"	2 1/2"	RD
<b>CAMARO FRONT CLIP</b>											
<b>MID LENGTH HEADERS</b>											
67-81	265-400	H8056	H8056-B	H8056-1	⬡	5, 17, 36, 52, 61, 93, 96, 202, 214	N	Y	1 5/8"	3"	OVL
67-81	265-400	H8021	H8021-B	H8021-1	⬡	5, 17, 52, 61, 73, 202	Y	N	1 5/8"	3"	RD
67-81	396-502	H8012	H8012-B	H8012-1	⬡	5, 52, 54, 69, 73, 202	Y	Y	1 3/4"	3"	SAP
67-81	396-502	H8013	H8013-B	H8013-1	⬡	5, 52, 54, 69, 73	Y	Y	1 7/8"	3"	SAP
67-69	LS1-LS6	-----	H8076	H8076-1	⬡	5, 180	Y	Y	1 5/8"	3"	RD
<b>LONG TUBE HEADERS</b>											
70-81	LS1-LS6	H8077	H8077-B	H8077-1	⬡	5, 85, 180	Y	Y	1 5/8"	3"	RD
<b>CHEVELLE, MALIBU, EL CAMINO FRONT CLIP</b>											
<b>MID LENGTH HEADERS</b>											
64-77	265-400	H8021	H8021-B	H8021-1	⬡	5, 17, 52, 61, 73	Y	N	1 5/8"	3"	RD
68-77	265-400	H8056	H8056-B	H8056-1	⬡	5, 17, 36, 52, 93, 96, 202, 214	N	Y	1 5/8"	3"	OVL
68-77	396-502	H8012	H8012-B	H8012-1	⬡	5, 52, 54, 69, 73	Y	Y	1 3/4"	3"	SAP
68-77	396-502	H8013	H8013-B	H8013-1	⬡	5, 52, 54, 69, 73	Y	Y	1 7/8"	3"	SAP
<b>LONG TUBE HEADERS</b>											
64-77	265-400	H8047	H8047-B	H8047-1	⬡	17, 36, 93, 96	Y	Y	1 5/8"	3"	OVL
<b>NEW</b> 78-87	265-400	H8096	H8096-B	H8096-1	⬡	17, 36, 93, 96, 214	Y	Y	1 5/8"	3"	OVL
<b>CLASSIC TRUCKS</b>											
<b>MID LENGTH HEADERS</b>											
55-65	265-400	H8021	H8021-B	H8021-1	⬡	5, 17, 52, 61, 73	Y	N	1 5/8"	3"	RD



## STREET ROD HEADER

YEARS	ENGINES	RAW STEEL	HI-TEMP BLACK COATING	METALLIC CERAMIC COATING	EMISSION CODES	FOOTNOTES	TRANS AUTO	STD	TUBE SIZE	COLL SIZE	PORT SHAPE
<b>FORD ENGINES</b>											
<b>CLASSIC TRUCKS</b>											
<b>LONG TUBE HEADERS</b>											
53-56	223 6 CYL	H8425	H8425-B	H8425-1	2	58, 59	Y	Y	1 1/2"	2"	REC
53-64	272-312Y	H8422	H8422-B	H8422-1	2		Y	Y	1 1/2"	3"	SAP
<b>FENDERWELL HEADERS</b>											
53-56	292-312Y	-----	H8440	-----	2	4	Y	N	1 1/2"	3"	SAP
<b>STREET ROD WITH FORD CHASSIS</b>											
<b>MID LENGTH HEADERS</b>											
27-48	260-351W	H8420	H8420-B	H8420-1	2	100, 228	Y	Y	1 5/8"	2 1/2"	REC
64-73	260-302W	H8433	H8433-B	H8433-1	2	5, 34, 196, 223	Y	Y	1 5/8"	3"	REC
27-48	351C-400M	H8435	H8435-B	H8435-1	2	5, 88, 171	Y	Y	1 3/4"	3"	OVL
27-48	351C	H8436	H8436-B	H8436-1	2	5, 89, 171	Y	Y	1 3/4"	3"	SAP
<b>LONG TUBE HEADERS</b>											
27-34	260-351W	H8429	H8429-B	H8429-1	2	19, 45, 47, 228	Y	Y	1 1/2"	3"	OVL
27-48	260-351W	H8473	H8473-B	H8473-1	2	47, 126, 228	Y	Y	1 5/8"- 2"	2 1/2"	OVL

## HEADER DIMENSIONS

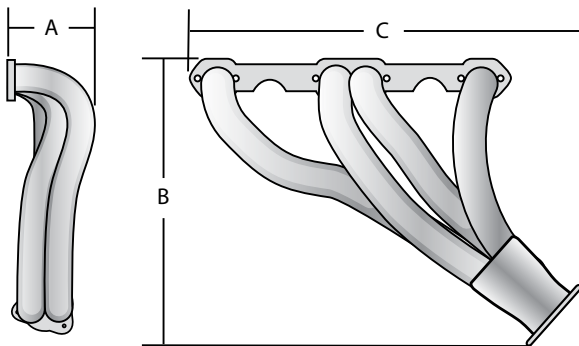

PART NO.	DIMENSION A		DIMENSION B		DIMENSION C	
	LEFT	RIGHT	LEFT	RIGHT	LEFT	RIGHT
H8012	3 1/4"	3 1/4"	16"	13"	22"	28"
H8013	3"	4"	12"	12"	19 1/2"	26"
H8017	3 1/2"	3 1/2"	16 3/4"	16 3/4"	19"	19"
H8018	3 1/2"	3 1/2"	17 1/2"	17 1/2"	23 1/4"	23 1/4"
H8021	4 1/8"	4 1/4"	15"	11"	23"	25"
H8033	7 1/2"	7 1/2"	14 1/2"	14 1/2"	27"	27"
H8035	10"	10"	17"	17"	29"	26 1/2"
H8036	7"	3 5/8"	8 1/2"	8 1/2"	21"	22"
H8039	3 3/4"	3 3/4"	17 1/2"	17 1/2"	23 1/4"	23 1/4"
H8056	3 1/2"	3 1/2"	13"	13"	17"	24"
H8073	3"	11"	17"	4"	7"	21"
H8420	4"	4"	8"	8"	22"	21"
H8429	3"	3 1/4"	18"	18 1/2"	19"	19 1/2"
H8433	3 1/2"	5"	8"	10"	24"	23"
H8435	4 1/2"	5"	9"	4"	16"	20 1/2"
H8436	3 1/2"	3 1/2"	8"	4 1/2"	15"	20"

## FOOTNOTES

4	Fenderwell exit	61	Does not fit 67-69 Camaro with A/C	180	Requires Doug's LS1 adapter plate kit P/N SK100, American Tour Specialties or equivalent
5	Mid length design for maximum ground clearance	69	Big block frame stands and motor mounts must be used to insure proper engine location and header fit.	196	Lakewood bell housings require clearancing for header tubes
10	Outside frame exit	73	See pages 13 for specific fit applications	202	Will fit Detroit Speed & Engineering front subframes with rack and pinion steering
15	Can be used with most oil filter system or transmission and starter combination	85	Equipped with O2 Sensor Bungs	214	Must use non-shell type motor mounts
16	Tucks very close to engine	88	Fits two barrel heads	223	Fits with Modern Driveline T5 cable clutches and AOD transmissions
17	Fits most angle plug heads	89	Fits four barrel heads (Boss 351)	228	Will not fit GT40 "P" head
19	Check motor mount position before ordering	93	Requires removal or modification of locking steering columns if equipped		
34	Rear Exit	96	Installation requires left side A/C bracket part number H7608.1979 and later vehicles with short compressors can use the stock bracket.		
36	Fits D-Port cylinder heads including ZZ4 crate engines				
45	Fits with side or front motor mounts				
46	Fits with stock, Mustang, Vega or Saginaw steering				
47	Fits with stock, Mustang and Vega steering				
52	Will not fit with Saginaw Close Ratio 825 Steering Box	100	Will not fit models with air injection cylinder heads		
54	Fits with manual and auto trans floor shifts only	126	Tri-Y design		
58	Header uses dual collector design for increased torque	171	Passenger side header has rear exit		
59	Fits the flathead six engine but does not provide for heat exchange to the stock cast intake manifold	172	Over frame design with outside exit and provision for exhaust system hookup (lakester style)		



### ENGINE SWAP HEADERS



### ENGINE SWAP HEADERS

Patriot offers some very popular engine swap headers that are designed to fit with most popular aftermarket engine swap kits. Patriot headers add the extra horsepower and torque that we know you are expecting.

YEARS	ENGINES	RAW STEEL	HI-TEMP BLACK COATING	METALLIC CERAMIC COATING	EMISSION CODES	FOOTNOTES	AUTO			STD		TUBE SIZE	COLL SIZE	PORT SHAPE		
							A/C	P/B	P/S	COL FLR	COL FLR					
<b>BEL AIR, WAGON &amp; NOMAD</b>																
<b>MID LENGTH HEADERS</b>																
55-57	LS1-LS6	H8046	H8046-B	H8046-1	◆	5, 85, 107, 108, 180, 212	Y	Y	Y	Y	Y	N	Y	1 3/4"	3"	RD
<b>LONG TUBE HEADERS</b>																
55-57	396-502	H8023	H8023-B	H8023-1	◆	3, 19, 23, 37, 105, 192	Y	Y	Y	Y	Y	N	N	1 7/8"	3"	SAP
55-57	396-502	H8078	H8078-B	H8078-1	◆	19, 37, 105, 211, 224	Y	Y	Y	N	Y	N	Y	1 7/8"	3"	SAP
<b>FENDERWELL HEADERS</b>																
55-57	396-502	H8035	H8035-B	H8035-1	◆	4, 13, 14, 15, 19	Y	Y	Y	Y	Y	N	Y	2"	3 1/2"	SAP
<b>CAMARO</b>																
<b>MID LENGTH HEADERS</b>																
67-69	LS1-LS6	-----	H8076	H8076-1	◆	5, 180	Y	Y	Y	N	Y	N	Y	1 5/8"	3"	RD
<b>LONG TUBE HEADERS</b>																
70-81	LS1-LS6	H8077	H8077-B	H8077-1	◆	5, 85, 180	Y	Y	Y	N	Y	N	Y	1 5/8"	3"	RD
<b>NOVA</b>																
<b>MID LENGTH HEADERS</b>																
68-74	LS1-LS6	-----	H8076	H8076-1	◆	5, 180	Y	Y	Y	N	Y	N	Y	1 5/8"	3"	RD
<b>LONG TUBE HEADERS</b>																
75-79	LS1-LS6	H8077	H8077-B	H8077-1	◆	5, 85, 180	Y	Y	Y	N	Y	N	Y	1 5/8"	3"	RD
<b>2WD 1/2 &amp; 3/4 TON PICKUP</b>																
73-87	LS1-LS6	H8087	H8087-B	H8087-1	◆	5, 87, 180	Y	Y	Y	Y	Y	N	N	1 3/4"	3"	RD
<b>2WD BLAZER, JIMMY, S10, S15</b>																
<b>MID LENGTH HEADERS</b>																
82-95	265-400	-----	H8036	H8036-1	◆	1, 5, 67, 68	Y	Y	Y	N	Y	N	N	1 1/2"	2 1/2"	RD
82-95	LS1-LS6	-----	H8073	H8073-1	◆	5, 67, 85	Y	Y	Y	Y	N	N	N	1 5/8"	2 1/2"	RD
<b>4WD BLAZER, JIMMY, S10, S15</b>																
82-95	265-400	-----	H8051	H8051-1	◆	1, 67, 78	Y	Y	Y	Y	Y	N	N	1 1/2"	2 1/2"	RD





## PASSENGER CAR HEADERS



### PASSENGER CAR HEADERS

Patriot offers headers for many applications at prices you can afford. Built with surface machined thick steel flanges for a great seal and mandrel bent mild steel tubing. Patriot headers come with installation hardware, collector reducers, gaskets and installation instructions.

YEARS	ENGINES	RAW STEEL	HI-TEMP BLACK COATING	METALLIC CERAMIC COATING	EMISSION CODES	FOOTNOTES	AUTO			STD			TUBE SIZE	COLL SIZE	PORT SHAPE	
							A/C	R/R	R/S	COL	ELF	COL				ELF
<b>AMC</b>																
<b>AMX, JAVELIN, REBEL, AMBASSADOR</b>																
<b>MID LENGTH HEADERS</b>																
NEW 68-70	290-401	H8600	H8600-B	H8600-1	◆	5, 164, 231	Y	Y	Y	Y	Y	N	Y	1 5/8"	3"	SAP
NEW 71-74	290-401	H8600	H8600-B	H8600-1	◆	155, 164, 231	Y	Y	Y	Y	Y	N	Y	1 5/8"	3"	SAP
<b>CHEVROLET</b>																
<b>BEL AIR, BISCAYNE, CAPRICE, IMPALA, NOMAD &amp; WAGON</b>																
<b>MID LENGTH HEADERS</b>																
55-57	265-400	H8025	H8025-B	H8025-1	◆	1, 3, 5, 19, 23, 60, 192	Y	Y	Y	Y	Y	N	N	1 5/8"	2 1/2"	RD
55-57	265-400	H8055	H8055-B	H8055-1	◆	3, 5, 17, 23, 36, 192	Y	Y	Y	Y	Y	N	Y	1 5/8"	2 1/2"	OVL
55-57	265-400	-----	H8063	H8063-1	◆	1, 5, 19, 23, 60, 211, 212	Y	Y	Y	Y	Y	N	Y	1 5/8"	3"	RD
55-57	LS1-LS6	H8046	H8046-B	H8046-1	◆	5, 85, 107, 108, 180, 212	Y	Y	Y	Y	Y	N	Y	1 3/4"	3"	RD
65-89	265-400	H8047	H8047-B	H8047-1	◆	17, 93, 96	Y	Y	Y	Y	Y	N	Y	1 5/8"	3"	OVL
71-94	265-400	H8056	H8056-B	H8056-1	◆	5, 17, 36, 93, 96, 202, 214	Y	Y	Y	N	N	N	Y	1 5/8"	3"	OVL
65-74	396-502	H8012	H8012-B	H8012-1	◆	5, 52, 53, 54, 69	Y	Y	Y	N	Y	N	Y	1 3/4"	3"	SAP
65-74	396-502	H8013	H8013-B	H8013-1	◆	5, 52, 53, 54, 69	Y	Y	Y	N	Y	N	Y	1 7/8"	3"	SAP
71-94	265-400	H8021	H8021-B	H8021-1	◆	5, 17, 52, 96	Y	Y	Y	Y	Y	N	N	1 5/8"	3"	RD
<b>LONG TUBE HEADERS</b>																
55-57	265-400	H8050	H8050-B	H8050-1	◆	17, 54, 76, 192	Y	Y	Y	N	Y	N	Y	1 3/4"	3"	REC
55-57	396-502	H8023	H8023-B	H8023-1	◆	3, 19, 23, 37, 105, 192	Y	Y	Y	Y	Y	N	N	1 7/8"	3"	SAP
55-57	396-502	H8078	H8078-B	H8078-1	◆	19, 37, 105, 211, 224	Y	Y	Y	N	Y	N	Y	1 7/8"	3"	SAP
65-70	396-502	H8062	H8062-B	H8062-1	◆	69	Y	Y	Y	Y	Y	Y	Y	2"	3 1/2"	SAP
71-74	396-502	H8024	H8024-B	H8024-1	◆	49, 69	Y	Y	Y	N	N	N	N	1 7/8"	3 1/2"	SAP
71-74	396-502	H8026	H8026-B	H8026-1	◆	49, 69	Y	Y	Y	N	N	N	N	2"	3 1/2"	SAP
<b>FENDERWELL HEADERS</b>																
55-57	396-502	H8035	H8035-B	H8035-1	◆	4, 13, 14, 15, 19	Y	Y	Y	Y	Y	N	Y	2"	3 1/2"	SAP

### FOOTNOTES

1	Does not fit angle plug heads	54	Fits with manual and auto trans floor shifts only	105	Original bellhousing frame mounts must be removed.
3	Fits with stock or 605 steering boxes, aftermarket side engine mounts and rear trans cross member	60	Will not fit with 168 tooth flywheels or kickout aftermarket starters	107	LS1/LS6 engines require the use of a LS1 oil pan for proper header fit.
4	Fenderwell exit	67	Fits with most engine swap kits	108	Will fit with 605 power steering box
5	Mid Length design for maximum ground clearance	68	Fits with Turbo 350 automatic transmissions with floor shifter only	155	Mid Length header that bolts directly to factory headpipes
13	May require smaller front tires to avoid contact.	69	Big block frame stands and motor mounts must be used to insure proper engine location and header fit.	164	Dog leg exhaust port
14	37-57 Chevy applications require alteration of emergency brake rod	76	Fits with either the Danchuk 3/4" forward or their stock location side mounts, rear transmission mount or equivalent and stock or 605 steering boxes. Stock mid mount and ears on the frame must be removed	180	Requires Doug's LS1 adapter plate kit P/N SK100, American Tour Specialties or equivalent
15	Can be used with most oil filter system or transmission and starter combination	78	Must replace the stock oil pan with a Canton 16-100 two piece or 16-100T one piece style rear main seal.	192	Header is designed to fit cars using original V-8 pitman arm part number 3719487 not 6 cylinder pitman arm number 3709877. Aftermarket pitman arms must be same configuration as OE for proper header fit.
17	Fits most angle plug heads	85	Equipped with O2 Sensor Bungs	202	Will fit Detroit Speed & Engineering front subframes with rack and pinion steering
19	Check motor mount position before ordering	87	Requires a Doug's LS1 /LS6 motor mount adapter plate kit P/N SK101 or equivalent.	211	Designed to fit with Maval/Unisteer rack and pinion steering systems
23	Will not fit if engine is located more than 3/4" forward for HEI firewall clearance. Fits with TCI engine mount kit PN 725-7005-80 and with the equivalent Danchuk mounts.	93	Requires removal or modification of locking steering columns if equipped	212	Will not fit manual transmission cars with factory Z bar clutch linkage
36	Fits D-Port cylinder heads including Z24 crate engines	96	Installation requires left side A/C bracket part number H7608.1979 and later vehicles with short compressors can use the stock bracket.	214	Must use non-shell type motor mounts
37	Fits standard deck big blocks only			224	Fits with Danchuk Mount kit #12184 or equivalent
49	Fits 71-74 passenger cars and wagons with auto trans column shift only			231	Modification to stock headpipe required
52	Will not fit with Saginaw Close Ratio 825 Steering Box				
53	Not recommended for generation six 502cid engines with aluminum heads				



## PASSENGER CAR HEADERS

YEARS	ENGINES	RAW STEEL	HI-TEMP BLACK COATING	METALLIC CERAMIC COATING	EMISSION CODES	FOOTNOTES	AUTO STD					TUBE SIZE	COLL SIZE	PORT SHAPE		
							AC	P/B	P/S	CO	FL				FL	FL
<b>CHEVROLET (CONTINUED)</b>																
<b>CAMARO</b>																
<b>MID LENGTH HEADERS</b>																
67-81	265-400	H8021	H8021-B	H8021-1	◆	5, 17, 52, 61, 96, 202	Y	Y	Y	Y	Y	N	N	1 5/8"	3"	RD
67-81	265-400	H8056	H8056-B	H8056-1	◆	5, 17, 36, 52, 61, 93, 96, 202, 214	Y	Y	Y	N	N	N	Y	1 5/8"	3"	OVL
82-92	265-400	H8068	H8068-B	H8068-1	◆	5, 17, 85	Y	Y	Y	N	Y	N	Y	1 5/8"	3"	RD
67-81	396-502	H8012	H8012-B	H8012-1	◆	5, 52, 53, 54, 69, 202	Y	Y	Y	N	Y	N	Y	1 3/4"	3"	SAP
67-81	396-502	H8013	H8013-B	H8013-1	◆	5, 52, 53, 54, 69	Y	Y	Y	N	Y	N	Y	1 7/8"	3"	SAP
67-69	LS1-LS6	-----	H8076	H8076-1	◆	5, 180	Y	Y	Y	N	Y	N	Y	1 5/8"	3"	RD
<b>LONG TUBE HEADERS</b>																
67-81	265-400	H8047	H8047-B	H8047-1	◆	17, 36, 61, 93, 96, 202	Y	Y	Y	Y	Y	N	Y	1 5/8"	3"	OVL
67-69	396-502	H8062	H8062-B	H8062-1	◆	69	Y	Y	Y	Y	Y	Y	Y	2"	3 1/2"	SAP
70-72	396-502	H8024	H8024-B	H8024-1	◆	54, 69	Y	Y	Y	N	Y	N	Y	1 7/8"	3 1/2"	SAP
70-72	396-502	H8026	H8026-B	H8026-1	◆	54, 69	Y	Y	Y	N	Y	N	Y	2"	3 1/2"	SAP
70-81	LS1-LS6	H8077	H8077-B	H8077-1	◆	5, 85, 180	Y	Y	Y	N	Y	N	Y	1 5/8"	3"	RD
<b>CHEVELLE, MALIBU, EL CAMINO</b>																
<b>MID LENGTH HEADERS</b>																
64-77	265-400	H8021	H8021-B	H8021-1	◆	5, 17, 52, 96	Y	Y	Y	Y	N	N	1 5/8"	3"	RD	
68-77	265-400	H8056	H8056-B	H8056-1	◆	5, 17, 36, 93, 96, 202, 214	Y	Y	Y	N	N	N	Y	1 5/8"	3"	OVL
68-77	396-502	H8012	H8012-B	H8012-1	◆	5, 52, 53, 54, 69	Y	Y	Y	N	Y	N	Y	1 3/4"	3"	SAP
68-77	396-502	H8013	H8013-B	H8013-1	◆	5, 52, 53, 54, 69	Y	Y	Y	N	Y	N	Y	1 7/8"	3"	SAP
<b>LONG TUBE HEADERS</b>																
64-77	265-400	H8047	H8047-B	H8047-1	◆	17, 36, 93, 96	Y	Y	Y	Y	Y	Y	Y	1 5/8"	3"	OVL
<b>NEW</b> 78-87	265-400	H8096	H8096-B	H8096-1	◆	17, 36, 93, 96, 214	Y	Y	Y	N	Y	N	Y	1 3/4"	3"	OVL
68-74	396-502	H8024	H8024-B	H8024-1	◆	69	Y	Y	Y	Y	Y	N	Y	1 7/8"	3 1/2"	SAP
68-74	396-502	H8026	H8026-B	H8026-1	◆	69	Y	Y	Y	Y	Y	N	Y	2"	3 1/2"	SAP
<b>CORVETTE</b>																
55-82	265-400	H8025	H8025-B	H8025-1	◆	1, 5, 60, 96	Y	Y	Y	Y	Y	N	N	1 5/8"	2 1/2"	RD
<b>MONTE CARLO</b>																
<b>MID LENGTH HEADERS</b>																
70-87	265-400	H8021	H8021-B	H8021-1	◆	5, 17, 52, 96	Y	Y	Y	Y	Y	N	N	1 5/8"	3"	RD
70-77	265-400	H8056	H8056-B	H8056-1	◆	5, 17, 36, 93, 96, 202, 214	Y	Y	Y	N	N	N	Y	1 5/8"	3"	OVL
70-77	396-502	H8012	H8012-B	H8012-1	◆	5, 52, 53, 54, 69	Y	Y	Y	N	Y	N	Y	1 3/4"	3"	SAP
70-77	396-502	H8013	H8013-B	H8013-1	◆	5, 52, 53, 54, 69	Y	Y	Y	N	Y	N	Y	1 7/8"	3"	SAP
<b>LONG TUBE HEADERS</b>																
70-77	265-400	H8047	H8047-B	H8047-1	◆	17, 36, 93, 96	Y	Y	Y	Y	Y	N	Y	1 5/8"	3"	OVL
<b>NEW</b> 78-88	265-400	H8096	H8096-B	H8096-1	◆	17, 36, 93, 96, 214	Y	Y	Y	N	Y	N	Y	1 3/4"	3"	OVL
70-74	396-502	H8024	H8024-B	H8024-1	◆	69	Y	Y	Y	Y	Y	N	Y	1 7/8"	3 1/2"	SAP
70-74	396-502	H8026	H8026-B	H8026-1	◆	69	Y	Y	Y	Y	Y	N	Y	2"	3 1/2"	SAP
<b>NOVA</b>																
<b>MID LENGTH HEADERS</b>																
68-79	265-400	H8021	H8021-B	H8021-1	◆	5, 17, 52, 96	N	Y	Y	Y	Y	N	N	1 5/8"	3"	RD
68-79	265-400	H8056	H8056-B	H8056-1	◆	5, 17, 36, 93, 96, 202, 214	Y	Y	Y	N	N	N	Y	1 5/8"	3"	OVL
68-79	396-502	H8012	H8012-B	H8012-1	◆	5, 52, 53, 54, 69	Y	Y	Y	N	Y	N	Y	1 3/4"	3"	SAP
68-79	396-502	H8013	H8013-B	H8013-1	◆	5, 52, 53, 54, 69	Y	Y	Y	N	Y	N	Y	1 7/8"	3"	SAP
68-74	LS1-LS6	-----	H8076	H8076-1	◆	5, 180	Y	Y	Y	N	Y	N	Y	1 5/8"	3"	RD
<b>LONG TUBE HEADERS</b>																
68-79	265-400	H8047	H8047-B	H8047-1	◆	17, 36, 93, 96	Y	Y	Y	Y	Y	Y	Y	1 5/8"	3"	OVL
68-74	396-502	H8062	H8062-B	H8062-1	◆	69	Y	Y	Y	Y	Y	Y	Y	2"	3 1/2"	SAP
75-79	LS1-LS6	H8077	H8077-B	H8077-1	◆	5, 85, 180	Y	Y	Y	N	Y	N	Y	1 5/8"	3"	RD





## PASSENGER CAR HEADERS

YEARS	ENGINES	RAW STEEL	HI-TEMP BLACK COATING	METALLIC CERAMIC COATING	EMISSION CODES	FOOTNOTES	AUTO STD						TUBE SIZE	COLL SIZE	PORT SHAPE	
							A/C	P/B	P/S	C/D	R/L	C/D				R/L
<b>DODGE / PLYMOUTH</b>																
<b>ALL A &amp; F BODIES</b>																
67-82	273-360	H8206	H8206-B	H8206-1	◆	203	Y	Y	Y	Y	Y	N	Y	1 5/8"	3"	SAP
<b>ALL B &amp; E BODIES</b>																
67-82	273-360	H8206	H8206-B	H8206-1	◆	203	Y	Y	Y	Y	Y	N	Y	1 5/8"	3"	SAP
67-74	383-440	H8207	H8207-B	H8207-1	◆	203	Y	Y	Y	Y	Y	Y	Y	1 7/8"	3"	SAP
<b>CHALLENGER /BARRACUDA</b>																
70-74	383-440	H8207	H8207-B	H8207-1	◆	203	Y	Y	Y	Y	Y	Y	Y	1 7/8"	3"	SAP
<b>CHRYSLER CORDOBA</b>																
1975	400	H8207	H8207-B	H8207-1	◆	203	Y	Y	Y	N	Y	N	N	1 7/8"	3"	SAP
<b>FORD</b>																
<b>MUSTANG</b>																
<b>MID LENGTH HEADERS</b>																
64-73	260-302W	H8433	H8433-B	H8433-1	◆	5, 18, 62, 64, 196, 197, 222, 223, 228	Y	Y	Y	Y	Y	N	Y	1 5/8"	3"	REC
86-93	255-302W	H8476	H8476-B	H8476-1	◆	113, 121, 228	Y	Y	Y	N	Y	N	Y	1 5/8"	3"	REC
94-95	255-302W	H8477	H8477-B	H8477-1	◆	55, 116, 121, 143	Y	Y	Y	N	Y	N	Y	1 5/8"	3"	REC
<b>LONG TUBE HEADERS</b>																
64-70	260-302W	-----	H8426	H8426-1	◆	26, 83, 84, 97, 102, 222, 228	Y	Y	Y	Y	Y	N	Y	1 1/2"-1 3/4"	2 1/2"	OVL
67-73	260-351W	H8403	H8403-B	H8403-1	◆	91, 98, 99, 221, 228, 229	Y	Y	Y	N	Y	N	Y	1 5/8"	3"	REC
67-70	351C	H8407	H8407-B	H8407-1	◆	88, 97	Y	Y	Y	N	Y	N	N	1 3/4"	2 1/2"	OVL
67-70	351C	H8408	H8408-B	H8408-1	◆	88, 97	Y	Y	Y	N	Y	N	N	1 3/4"	2 1/2"	SAP
67-70	351C	H8409	H8409-B	H8409-1	◆	88, 97	Y	Y	Y	N	N	N	Y	1 3/4"	2 1/2"	OVL
67-70	351C	H8411	H8411-B	H8411-1	◆	88, 97	Y	Y	Y	N	N	N	Y	1 3/4"	2 1/2"	SAP
71-73	351C	H8412	H8412-B	H8412-1	◆	88, 97	Y	Y	Y	N	Y	N	Y	1 3/4"	3"	OVL
71-73	351C	H8413	H8413-B	H8413-1	◆	88, 97	Y	Y	Y	N	Y	N	Y	1 3/4"	3"	SAP
<b>FAIRLANE, TORINO</b>																
<b>MID LENGTH HEADERS</b>																
68-73	260-302W	H8433	H8433-B	H8433-1	◆	5, 18, 62, 64, 196, 197, 222, 223, 228	Y	Y	Y	Y	Y	N	Y	1 5/8"	3"	REC
<b>LONG TUBE HEADERS</b>																
67-73	260-351W	H8403	H8403-B	H8403-1	◆	91, 98, 99, 221, 228, 229	Y	Y	Y	Y	Y	N	Y	1 5/8"	3"	REC
70-71	351C	H8407	H8407-B	H8407-1	◆	88, 97	Y	Y	Y	N	Y	N	N	1 3/4"	2 1/2"	OVL
70-71	351C	H8408	H8408-B	H8408-1	◆	88, 97	Y	Y	Y	N	Y	N	N	1 3/4"	2 1/2"	SAP
70-71	351C	H8409	H8409-B	H8409-1	◆	88, 97	Y	Y	Y	N	N	N	Y	1 3/4"	2 1/2"	OVL
70-71	351C	H8411	H8411-B	H8411-1	◆	88, 97	Y	Y	Y	N	N	N	Y	1 3/4"	2 1/2"	SAP
<b>FALCON</b>																
66-73	260-302W	H8403	H8403-B	H8403-1	◆	97, 98, 221, 228	Y	Y	Y	Y	Y	N	Y	1 5/8"	3"	REC

### FOOTNOTES

<p>1 Does not fit angle plug heads</p> <p>5 Mid Length design for maximum ground clearance</p> <p>17 Fits most angle plug heads</p> <p>18 Header installation requires the use of the 1965-66 Non Hi-Po V8 clutch equalizer bar</p> <p>26 67-70 models require additional driver's side header clearance around the steering box</p> <p>36 Fits D-Port cylinder heads including ZZ4 crate engines</p> <p>52 Will not fit with Saginaw Close Ratio 825 Steering Box</p> <p>53 Not recommended for generation six 502cid engines with aluminum heads</p> <p>54 Fits with manual and auto trans floor shifts only</p> <p>55 Fits GT40 "P" head</p> <p>60 Will not fit with 168 tooth flywheels or kickout aftermarket starters</p> <p>61 Does not fit 67-69 Camaro with A/C</p> <p>62 Must use 66 1/2 or later frame brackets (approx. 1" higher than 65 and early 66 style)</p> <p>64 Fits with manual transmissions using 85-95 bellhousings with cable clutch kits</p> <p>69 Big block frame stands and motor mounts must be used to insure proper engine location and header fit.</p>	<p>83 Fits with manual transmissions using 10" or 10.5" clutch only. 1968-up bellhousings require driver's side header clearance</p> <p>84 Non-HiPo cars with manual transmission may need header clearance for clutch linkage</p> <p>85 Equipped with O2 Sensor Bungs</p> <p>88 Fits two barrel heads</p> <p>89 Fits four barrel heads (Boss 351)</p> <p>91 Y Pipe available part number H1100</p> <p>93 Requires removal or modification of locking steering columns if equipped</p> <p>96 Installation requires left side A/C bracket part number H7608, 1979 and later vehicles with short compressors can use the stock bracket.</p> <p>97 Installation requires power steering bracket PN H7609.</p> <p>98 Fits with C-6 transmission.</p> <p>99 Does not fit 1971-73 Mustang/Cougar with manual transmission.</p> <p>102 Replica of early Shelby Tri-Y header.</p> <p>113 Replacement shorty style header which bolts directly to '86 and later factory headpipe</p>	<p>116 Replacement shorty style header which bolts directly to '94 and later factory headpipe</p> <p>121 50-State Legal C.A.R.B. E.O. #D-57-29, D-57-31</p> <p>143 Comes with EGR provision</p> <p>180 Requires Doug's LS1 adapter plate kit P/N SK100, American Tour Specialties or equivalent.</p> <p>196 Lakewood bell housings require clearing for header tubes</p> <p>197 Use recommended C5ZZ16A052E "export brace" if shock mount center to center dimension is less than 33 3/4"</p> <p>202 Will fit Detroit Speed &amp; Engineering front subframes with rack and pinion steering</p> <p>203 Will not fit models equipped with air injection pump without modification</p> <p>214 Must use non-shell type motor mounts</p> <p>221 Will fit with Borgeson Power Steering Box Conversion</p> <p>222 Fits TCI, Heidts, or similar Mustang II style front suspension conversion</p> <p>223 Fits with Modern Driveline T5 cable clutches and AOD transmissions</p> <p>228 Will not fit GT40 "P" head</p> <p>229 Will fit T-5 transmission with hydraulic clutch or stock Z Bar</p>
--	---	---



## PASSENGER CAR HEADERS

YEARS	ENGINES	RAW STEEL	HI-TEMP BLACK COATING	METALLIC CERAMIC COATING	EMISSION CODES	FOOTNOTES	AUTO STD					TUBE SIZE	COLL SIZE	PORT SHAPE			
							AC	P/B	P/S	CO	FL				CO	FL	
<b>FORD (CONTINUED)</b>																	
<b>MAVERICK</b>																	
70-77	260-302W	H8403	H8403-B	H8403-1	◆	97, 98, 221, 228	Y	Y	Y	N	Y	N	Y	1 5/8"	3"	REC	
<b>RANCHERO</b>																	
<b>MID LENGTH HEADERS</b>																	
68-73	260-302W	H8433	H8433-B	H8433-1	◆	5, 18, 62, 64, 196, 197, 223, 228	Y	Y	Y	Y	Y	N	Y	1 5/8"	3"	REC	
<b>LONG TUBE HEADERS</b>																	
67-73	260-351W	H8403	H8403-B	H8403-1	◆	91, 98, 99, 221, 228, 229	Y	Y	Y	N	Y	N	Y	1 5/8"	3"	REC	
70-71	351C	H8407	H8407-B	H8407-1	◆	88, 97	Y	Y	Y	N	Y	N	N	1 3/4"	2 1/2"	OVL	
70-71	351C	H8408	H8408-B	H8408-1	◆	88, 97	Y	Y	Y	N	Y	N	N	1 3/4"	2 1/2"	SAP	
70-71	351C	H8409	H8409-B	H8409-1	◆	88, 97	Y	Y	Y	N	N	N	Y	1 3/4"	2 1/2"	OVL	
70-71	351C	H8411	H8411-B	H8411-1	◆	88, 97	Y	Y	Y	N	N	N	Y	1 3/4"	2 1/2"	SAP	
<b>MERCURY</b>																	
<b>COUGAR</b>																	
<b>MID LENGTH HEADERS</b>																	
64-73	260-302W	H8433	H8433-B	H8433-1	◆	5, 18, 62, 64, 196, 197, 222, 223, 228	Y	Y	Y	Y	Y	N	Y	1 5/8"	3"	REC	
<b>LONG TUBE HEADERS</b>																	
64-70	260-302W	-----	H8426	H8426-1	◆	26, 83, 84, 97, 102, 222, 228	Y	Y	Y	Y	Y	N	Y	1 1/2"-1 3/4"	2 1/2"	OVL	
67-73	260-351W	H8403	H8403-B	H8403-1	◆	91, 98, 99, 221, 228, 229	Y	Y	Y	N	Y	N	Y	1 5/8"	3"	REC	
67-70	351C	H8407	H8407-B	H8407-1	◆	88, 97	Y	Y	Y	N	Y	N	N	1 3/4"	2 1/2"	OVL	
67-70	351C	H8408	H8408-B	H8408-1	◆	88, 97	Y	Y	Y	N	Y	N	N	1 3/4"	2 1/2"	SAP	
67-70	351C	H8409	H8409-B	H8409-1	◆	88, 97	Y	Y	Y	N	N	N	Y	1 3/4"	2 1/2"	OVL	
67-70	351C	H8411	H8411-B	H8411-1	◆	88, 97	Y	Y	Y	N	N	N	Y	1 3/4"	2 1/2"	SAP	
71-73	351C	H8412	H8412-B	H8412-1	◆	88, 97	Y	Y	Y	N	Y	N	Y	1 3/4"	3"	OVL	
71-73	351C	H8413	H8413-B	H8413-1	◆	88, 97	Y	Y	Y	N	Y	N	Y	1 3/4"	3"	SAP	
<b>CYCLONE, MONTEGO</b>																	
<b>MID LENGTH HEADERS</b>																	
68-73	260-302W	H8433	H8433-B	H8433-1	◆	5, 18, 62, 64, 196, 197, 222, 223, 228	Y	Y	Y	Y	Y	N	Y	1 5/8"	3"	REC	
<b>LONG TUBE HEADERS</b>																	
67-73	260-351W	H8403	H8403-B	H8403-1	◆	91, 98, 99, 221, 228, 229	Y	Y	Y	Y	Y	N	Y	1 5/8"	3"	REC	
70-71	351C	H8407	H8407-B	H8407-1	◆	88, 97	Y	Y	Y	N	Y	N	N	1 3/4"	2 1/2"	OVL	
70-71	351C	H8408	H8408-B	H8408-1	◆	88, 97	Y	Y	Y	N	Y	N	N	1 3/4"	2 1/2"	SAP	
70-71	351C	H8409	H8409-B	H8409-1	◆	88, 97	Y	Y	Y	N	N	N	Y	1 3/4"	2 1/2"	OVL	
70-71	351C	H8411	H8411-B	H8411-1	◆	88, 97	Y	Y	Y	N	N	N	Y	1 3/4"	2 1/2"	SAP	
<b>COMET</b>																	
66-69	260-302W	H8403	H8403-B	H8403-1	◆	97, 98, 221, 228	Y	Y	Y	N	Y	N	Y	1 5/8"	3"	REC	
<b>OLDSMOBILE</b>																	
<b>CALAIS</b>																	
<b>MID LENGTH HEADERS</b>																	
78-84	265-400	H8021	H8021-B	H8021-1	◆	5, 17, 36, 93, 96, 106, 214	Y	Y	Y	Y	Y	N	N	1 5/8"	3"	RD	
<b>LONG TUBE HEADERS</b>																	
<b>NEW</b>	78-84	265-400	H8096	H8096-B	H8096-1	◆	17, 36, 93, 96, 106, 214	Y	Y	Y	N	Y	N	Y	1 3/4"	3"	OVL
<b>CUTLASS / 442</b>																	
<b>MID LENGTH HEADERS</b>																	
78-88	265-400	H8021	H8021-B	H8021-1	◆	5, 17, 36, 93, 96, 106, 214	Y	Y	Y	Y	Y	N	N	1 5/8"	3"	RD	
<b>LONG TUBE HEADERS</b>																	
65-75	400-455	H8101	H8101-B	H8101-1	◆		Y	Y	Y	Y	Y	N	Y	1 3/4"	3"	SAP	
68-77	350-403	H8100	H8100-B	H8100-1	◆		Y	Y	Y	Y	N	N	Y	1 5/8"	2 1/2"	SAP	
<b>NEW</b>	78-88	265-400	H8096	H8096-B	H8096-1	◆	17, 36, 93, 96, 106, 214	Y	Y	Y	N	Y	N	Y	1 3/4"	3"	OVL
<b>DELTA 88</b>																	
71-75	400-455	H8101	H8101-B	H8101-1	◆		Y	Y	Y	Y	Y	N	N	1 3/4"	3"	SAP	
<b>VISTA CRUISER WAGON</b>																	
<b>MID LENGTH HEADERS</b>																	
78-83	265-400	H8021	H8021-B	H8021-1	◆	5, 17, 36, 93, 96, 106, 214	Y	Y	Y	Y	Y	N	N	1 5/8"	3"	RD	
<b>LONG TUBE HEADERS</b>																	
71-74	400-455	H8101	H8101-B	H8101-1	◆		Y	Y	Y	Y	Y	N	N	1 3/4"	3"	SAP	
<b>NEW</b>	78-83	265-400	H8096	H8096-B	H8096-1	◆	17, 36, 93, 96, 106, 214	Y	Y	Y	N	Y	N	Y	1 3/4"	3"	OVL



## PASSENGER CAR HEADERS

YEARS	ENGINES	RAW STEEL	HI-TEMP BLACK COATING	METALLIC CERAMIC COATING	EMISSION CODES	FOOTNOTES	AUTO STD						TUBE SIZE	COLL SIZE	PORT SHAPE		
							A/C	P/B	P/S	C/D	L/F	C/D				L/F	
<b>PONTIAC</b>																	
<b>BONNEVILLE</b>																	
<b>MID LENGTH HEADERS</b>																	
82-86	265-400	H8021	H8021-B	H8021-1	5	5, 17, 36, 93, 96, 106, 214	Y	Y	Y	Y	Y	N	N	1 5/8"	3"	RD	
<b>LONG TUBE HEADERS</b>																	
<b>NEW</b>	82-86	265-400	H8096	H8096-B	H8096-1	5	17, 36, 93, 96, 106, 214	Y	Y	Y	N	Y	N	Y	1 3/4"	3"	OVL
<b>FIREBIRD, TRANS AM</b>																	
<b>MID LENGTH HEADERS</b>																	
82-92	265-400	H8068	H8068-B	H8068-1	5	5, 17, 85	Y	Y	Y	N	Y	N	Y	1 5/8"	3"	RD	
<b>LONG TUBE HEADERS</b>																	
67-69	350-455	H8302	H8302-B	H8302-1	4	104	Y	Y	Y	N	Y	N	Y	1 5/8"	3"	SAP	
70-79	350-455	H8301	H8301-B	H8301-1	4	104	Y	Y	Y	N	Y	N	Y	1 5/8"	3"	SAP	
<b>NEW</b>	77-78	350-403 OLDS	H8100	H8100-B	H8100-1	5		Y	Y	Y	N	Y	N	Y	1 5/8"	2 1/2"	SAP
<b>GRAND PRIX</b>																	
<b>MID LENGTH HEADERS</b>																	
78-87	265-400	H8021	H8021-B	H8021-1	5	5, 17, 36, 93, 96, 106, 214	Y	Y	Y	Y	Y	N	N	1 5/8"	3"	RD	
<b>LONG TUBE HEADERS</b>																	
<b>NEW</b>	78-87	265-400	H8096	H8096-B	H8096-1	5	17, 36, 93, 96, 106, 214	Y	Y	Y	N	Y	N	Y	1 3/4"	3"	OVL
<b>GTO, LE MANS, GRAND AM</b>																	
64-75	326-455	H8301	H8301-B	H8301-1	4	104	Y	Y	Y	N	Y	N	Y	1 5/8"	3"	SAP	

### FOOTNOTES

5	Mid Length design for maximum ground clearance	85	Equipped with O2 Sensor Bungs	106	Fits factory installed Chevrolet 267, 305, 350 engines.
17	Fits most angle plug heads	88	Fits two barrel heads	196	Lakewood bell housings require clearancing for header tubes
18	Header installation requires the use of the 1965-66 Non Hi-Po V8 clutch equalizer bar	89	Fits four barrel heads (Boss 351)	197	Use recommended C5ZZ16A052E "export brace" if shock mount center to center dimension is less than 33 3/4"
26	67-70 models require additional driver's side header clearance around the steering box	91	Y Pipe available part number H1100	214	Must use non-shell type motor mounts
36	Fits D-Port cylinder heads including ZZ4 crate engines	93	Requires removal or modification of locking steering columns if equipped	221	Will fit with Borgeson Power Steering Box Conversion
62	Must use 66 1/2 or later frame brackets (approx. 1" higher than 65 and early 66 style)	96	Installation requires left side A/C bracket part number H7608.1979 and later vehicles with short compressors can use the stock bracket.	222	Fits TC1, Heidts, or similar Mustang II style front suspension conversion
64	Fits with manual transmissions using 85-95 bellhousings with cable clutch kits	97	Installation requires power steering bracket PN H7609.	223	Fits with Modern Driveline T5 cable clutches and AOD transmissions
83	Fits with manual transmissions using 10" or 10.5" clutch only. 1968-up bellhousings require driver's side header clearance	98	Fits with C-6 transmission.	228	Will not fit GT40 "P" head
84	Non-HiPo cars with manual transmission may need header clearance for clutch linkage	99	Does not fit 1971-73 Mustang/Cougar with manual transmission.	229	Will fit T-5 transmission with hydraulic clutch or stock Z Bar
		102	Replica of early Shelby Tri-Y header.		
		104	Some factory heads do not have end bolt holes and should be drilled and tapped to assure proper sealing.		



## TRUCK HEADERS

YEARS	ENGINES	RAW STEEL	HI-TEMP BLACK COATING	METALLIC CERAMIC COATING	EMISSION CODES	FOOTNOTES	AUTO STD					TUBE SIZE	COLL SIZE	PORT SHAPE		
							AC	P/B	P/S	CO	LF				CO	LF
<b>CHEVROLET / GMC</b>																
<b>2WD 1/2, 3/4, 1 TON / 1500, 2500, 3500 TRUCKS</b>																
<b>MID LENGTH HEADERS</b>																
55-66	265-400	H8021	H8021-B	H8021-1	◆	5, 17, 52	Y	Y	Y	Y	Y	N	N	1 5/8"	3"	RD
73-87	LS1-LS6	H8087	H8087-B	H8087-1	◆	5, 87	Y	Y	Y	Y	Y	N	N	1 3/4"	3"	RD
<b>LONG TUBE HEADERS</b>																
67-87	265-400	H8048	H8048-B	H8048-1	◆	17, 36, 94, 95, 96	Y	Y	Y	Y	Y	N	N	1 5/8"	3"	OVL
88-98	265-400	H8059	H8059-B	H8059-1	◆	85, 111	Y	Y	Y	Y	N	N	N	1 5/8"	2 1/2"	OVL
68-87	396-502	H8054	H8054-B	H8054-1	◆	69, 94, 95	Y	Y	Y	Y	Y	N	N	1 3/4"	3"	SAP
68-91	396-502	H8054	H8054-B	H8054-1	◆	CREW CAB ONLY 69, 94, 95	Y	Y	Y	Y	Y	N	N	1 3/4"	3"	SAP
88-98	396-502	H8058	H8058-B	H8058-1	◆	85	Y	Y	Y	Y	N	N	N	1 3/4"	3"	SAP
92-00	396-502	H8058	H8058-B	H8058-1	◆	CREW CAB ONLY 85	Y	Y	Y	Y	N	N	N	1 3/4"	3"	SAP
99-06	4.8/5.3/6.0	H8057	H8057-B	H8057-1	◆		Y	Y	Y	Y	Y	Y	Y	1 5/8"	3"	RD
07-13	4.8-6.2L	H8079	H8079-B	H8079-1	◆	85	Y	Y	Y	Y	N	N	N	1 5/8"	3"	RD
<b>2WD BLAZER, JIMMY, SUBURBAN, YUKON XL, TAHOE, YUKON</b>																
<b>MID LENGTH HEADERS</b>																
73-91	LS1-LS6	H8087	H8087-B	H8087-1	◆	5, 87	Y	Y	Y	Y	Y	N	N	1 3/4"	3"	RD
<b>LONG TUBE HEADERS</b>																
69-91	265-400	H8048	H8048-B	H8048-1	◆	17, 36, 94, 95, 96	Y	Y	Y	Y	Y	N	N	1 5/8"	3"	OVL
92-99	265-400	H8059	H8059-B	H8059-1	◆	85, 111	Y	Y	Y	Y	N	N	N	1 5/8"	2 1/2"	OVL
68-91	396-502	H8054	H8054-B	H8054-1	◆	69, 94, 95	Y	Y	Y	Y	Y	N	N	1 3/4"	3"	SAP
92-99	396-502	H8058	H8058-B	H8058-1	◆	85	Y	Y	Y	Y	N	N	N	1 3/4"	3"	SAP
00-06	4.8/5.3/6.0	H8057	H8057-B	H8057-1	◆		Y	Y	Y	Y	Y	Y	Y	1 5/8"	3"	RD
07-14	4.8-6.2L	H8079	H8079-B	H8079-1	◆	85	Y	Y	Y	Y	N	N	N	1 5/8"	3"	RD
<b>2WD S10, S15, BLAZER, JIMMY, (ENGINE SWAP)</b>																
<b>MID LENGTH HEADERS</b>																
82-02	265-400	-----	H8036	H8036-1	◆	1, 5, 67, 68	Y	Y	Y	N	Y	N	N	1 1/2"	2 1/2"	RD
82-02	LS1-LS6	-----	H8073	H8073-1	◆	5, 67, 85	Y	Y	Y	Y	N	N	N	1 5/8"	2 1/2"	RD
<b>4WD 1/2, 3/4, 1 TON / 1500, 2500, 3500 TRUCKS</b>																
<b>LONG TUBE HEADERS</b>																
67-87	265-400	H8049	H8049-B	H8049-1	◆	1, 95, 96	Y	Y	Y	Y	Y	N	N	1 5/8"	2 1/2"	RD
88-98	265-400	H8059	H8059-B	H8059-1	◆	85, 111	Y	Y	Y	Y	N	N	N	1 5/8"	2 1/2"	SAP
68-87	396-502	H8054	H8054-B	H8054-1	◆	69, 94, 95	Y	Y	Y	Y	Y	N	N	1 3/4"	3"	SAP
68-91	396-502	H8054	H8054-B	H8054-1	◆	CREW CAB ONLY 69, 94, 95	Y	Y	Y	Y	Y	N	N	1 3/4"	3"	SAP
88-95	396-502	H8058	H8058-B	H8058-1	◆	85, 111	Y	Y	Y	Y	N	N	N	1 3/4"	3"	SAP
92-00	396-502	H8058	H8058-B	H8058-1	◆	CREW CAB ONLY 85, 111	Y	Y	Y	Y	N	N	N	1 3/4"	3"	SAP
00-06	4.8/5.3/6.0	H8057	H8057-B	H8057-1	◆		Y	Y	Y	Y	Y	Y	Y	1 5/8"	3"	RD
07-13	4.8-6.2L	H8079	H8079-B	H8079-1	◆	85	Y	Y	Y	Y	N	N	N	1 5/8"	3"	RD
<b>4WD BLAZER, JIMMY, SUBURBAN, YUKON XL, TAHOE, YUKON</b>																
<b>LONG TUBE HEADERS</b>																
69-91	265-400	H8049	H8049-B	H8049-1	◆	1, 95, 96	Y	Y	Y	Y	Y	N	N	1 5/8"	2 1/2"	RD
92-99	265-400	H8059	H8059-B	H8059-1	◆	85	Y	Y	Y	Y	N	N	N	1 5/8"	2 1/2"	SAP
92-99	396-502	H8058	H8058-B	H8058-1	◆	85, 111	Y	Y	Y	Y	N	N	N	1 3/4"	3"	SAP
00-06	4.8/5.3/6.0	H8057	H8057-B	H8057-1	◆		Y	Y	Y	Y	Y	Y	Y	1 5/8"	3"	RD
07-14	4.8-6.2L	H8079	H8079-B	H8079-1	◆	85	Y	Y	Y	Y	N	N	N	1 5/8"	3"	RD
<b>4WD , S10, S15, BLAZER, JIMMY (ENGINE SWAP)</b>																
<b>MID LENGTH HEADERS</b>																
82-02	265-400	H8051	H8051-B	H8051-1	◆	1, 5, 67, 78	Y	Y	Y	N	Y	N	N	1 1/2"	2 1/2"	RD



## TRUCK HEADERS

YEARS	ENGINES	RAW STEEL	HI-TEMP BLACK COATING	METALLIC CERAMIC COATING	EMISSION CODES	FOOTNOTES	AUTO STD						TUBE SIZE	COLL SIZE	PORT SHAPE		
							A/C	P/B	P/S	C/D	P/F	C/D				P/F	
<b>FORD TRUCKS</b>																	
<b>PICKUP</b>																	
53-56	223 6 CYL	H8425	H8425-B	H8425-1	1	59, 85	Y	Y	Y	Y	Y	Y	1 1/2"	2"	REC		
53-56	272-312Y	-----	H8440	-----	1	4	Y	Y	Y	Y	N	Y	1 1/2"	3"	SAP		
54-64	272-292Y	H8422	H8422-B	H8422-1	1	110	Y	Y	Y	Y	N	Y	1 1/2"	3"	SAP		
<b>2WD F150, F250</b>																	
65-74	260-302W	H8405	H8405-B	H8405-1	2	90, 100, 228	Y	Y	Y	Y	N	N	1 5/8"	2 1/2"	REC		
65-76	352-390	H8406	H8406-B	H8406-1	2		Y	Y	Y	Y	Y	Y	1 3/4"	2 1/2"	SAP		
<b>4WD F250, F350</b>																	
65-74	260-302W	H8405	H8405-B	H8405-1	2	90, 100, 228	Y	Y	Y	Y	N	N	1 5/8"	2 1/2"	REC		
<b>JEEP</b>																	
<b>CJ5, CJ7, CJ8</b>																	
<b>NEW</b>	72-79	290-401	H8600	H8600-B	H8600-1	2	155, 164	Y	Y	Y	N	Y	N	Y	1 5/8"	3"	SAP
<b>CHEROKEE, WAGONEER</b>																	
<b>NEW</b>	72-79	290-401	H8600	H8600-B	H8600-1	2	155, 164	Y	Y	Y	Y	Y	Y	1 5/8"	3"	SAP	
<b>NEW</b>	81-91	290-401	H8600	H8600-B	H8600-1	2	155, 164	Y	Y	Y	Y	Y	Y	1 5/8"	3"	SAP	
<b>J10 AND J20 PICKUPS</b>																	
<b>NEW</b>	72-79	290-401	H8600	H8600-B	H8600-1	2	155, 164	Y	Y	Y	Y	Y	Y	1 5/8"	3"	SAP	
<b>NEW</b>	81-91	290-401	H8600	H8600-B	H8600-1	2	155, 164	Y	Y	Y	Y	Y	Y	1 5/8"	3"	SAP	

### FOOTNOTES

- |  |   |   |
|--|---|---|
| <p>1 Does not fit angle plug heads</p> <p>4 Fenderwell exit</p> <p>5 Mid Length design for maximum ground clearance</p> <p>17 Fits most angle plug heads</p> <p>36 Fits D-Port cylinder heads including ZZ4 crate engines</p> <p>52 Will not fit with Saginaw Close Ratio 825 Steering Box</p> <p>59 Fits the flathead six engine but does not provide for heat exchange to the stock cast intake manifold</p> <p>67 Fits with most engine swap kits</p> <p>68 Fits with Turbo 350 automatic transmissions with floor shifter only</p> <p>69 Big block frame stands and motor mounts must be used to insure proper engine location and header fit.</p> | <p>78 Must replace the stock oil pan with a Canton 16-100 two piece or 16-100T one piece style rear main seal.</p> <p>85 Equipped with O2 Sensor Bungs</p> <p>87 Requires a Doug's LS1 /LS6 motor mount adapter plate kit P/N SK101 or equivalent.</p> <p>90 Does not fit with C-6 transmission</p> <p>94 Non catalytic converter equipped.</p> <p>95 Reducers available with O2 sensor fitting see catalog page 27.</p> <p>96 Installation requires left side A/C bracket part number H7608.1979 and later vehicles with short compressors can use the stock bracket.</p> <p>100 Will not fit models with air injection cylinder heads</p> | <p>110 Fits 1953 models with transplanted Y block engines when 1954-64 Y block motor mounts are used.</p> <p>111 Long tube headers for closed course competition only</p> <p>155 Shorty header that bolts directly to factory headpipes</p> <p>164 Dog leg exhaust port</p> <p>228 Will not fit GT40 "P" head</p> |
|--|---|---|



## CLASSIC IMPORT HEADERS

YEARS	ENGINES	HI-TEMP BLACK COATING	METALLIC CERAMIC COATING	EMISSION CODES	FOOTNOTES	AUTO STD					TUBE SIZE	COLL SIZE	PORT SHAPE		
						AC	P/B	P/S	CO	FL				CO	FL
<b>JAGUAR</b>															
<b>XKE E-TYPE SERIES 1&amp;2</b>															
61-71	3.8-4.2L	H4830	H4830-1	◆	103	Y	Y	Y	Y	Y	N	Y	1 5/8"	2 1/2"	REC.
<b>MG</b>															
<b>MGB, MGB-GT</b>															
PRE 75	1.8L	H4800	H4800-1	◆		Y	Y	Y	N	N	N	Y	1 3/8"	2"	RD.
<b>MIDGET</b>															
75-80	1.5L	H4803	-----	◆		Y	Y	Y	N	N	N	Y	1 1/4"	2"	OVL.
<b>VOLVO</b>															
<b>544, 120, 140, P1800, P1800S, P1800ES</b>															
62-69	B18, B20	H4850	H4850-1	◆	32	Y	Y	Y	N	N	N	Y	1 1/2"	2"	REC.
62-69	B18, B20	H4851	H4851-1	◆	75	Y	Y	Y	N	N	N	Y	1 1/2"	2"	REC.

## JAGUAR EXHAUST SYSTEMS

Jaguar XKE owners don't have to pay ridiculously high prices for mufflers anymore! Patriot offers ready to install performance muffler systems for E-Type cars from 1961 thru 1971. The show quality chrome finish looks great and provides improved corrosion resistance. Our unique muffler core design effectively reduces restriction and absorbs more noise than the designs used by other manufacturers.

DESCRIPTION	PART NO.	TUBE DIAMETER	CASE DIAMETER
<b>XKE E-TYPE SERIES 1</b>			
61-64 3.8L	H3832	1 3/4"	3"
64 1/2-67 4.2L	H3834	1 3/4"	3"
<b>XKE E-TYPE SERIES 2</b>			
69-71 4.2L	H3833	1 3/4"	3"



H3832



H3833



H3834

## RACECAR HEADERS



## WELD-UP RACE KITS

Patriot Weld-up kits work great for racers who need to build custom headers when a specific fit header is not available. Kits come with mandrel bent one piece primaries, two 3/8" precision machined flanges and your choice on most applications of either formed weld-on or slip-on collectors incorporating unique long transition to provide better flow. Mounting bolts, gaskets and collector locking tabs (slip-on style only) are also included.

ENGINE	PART NO.	TUBE SIZE	COLLECTOR TYPE	COLLECTOR SIZE	PORT SHAPE
CHEVROLET BB	H8005	2"	WELD-ON	3 1/2"	SAP
CHEVROLET BB	H8091	2 1/4"	WELD-ON	4"	RD
CHEVROLET BB	H8092	2 3/8"	WELD-ON	4 1/2"	RD
CHEVROLET BB	H8093	2 3/8"	SLIP-ON	4 1/2"	RD
CHEVROLET BB	H8094	2 1/2"	WELD-ON	5"	RD
CHEVROLET BB	H8095	2 1/2"	SLIP-ON	5"	RD



### RACECAR HEADERS

## RACECAR HEADERS

Patriot offers affordable racing headers and do-it-yourself weld up kits for many applications in the popular IMCA Modified, Sprint Car, Late Model Sportsman, Street Stock, Mini-Stock and Pony Car classes. Our headers use precision machined flanges and lightweight but strong 18 gauge tubing. Mandrel bent primaries and long transition collectors reduce backpressure for increased exhaust velocity. Some applications are available with our stepped pipe design to help broaden the torque curve for better corner acceleration.



YEARS	ENGINES	RAW STEEL	HI-TEMP BLACK COATING	METALLIC CERAMIC COATING	EMISSION CODES	FOOTNOTES	TRANS AUTO	STD	TUBE SIZE	COLL SIZE	PORT SHAPE
<b>MINI STOCK / PONY CAR HEADERS</b>											
<b>PINTO</b>											
71-80	2.3L	H8401	H8401-B	H8401-1	Ⓢ	56, 70, 71	Y	Y	1 5/8"-1 3/4"	3"	OVL
71-80	2.3L	H8402	H8402-B	H8402-1	Ⓢ	56, 72, 188	Y	Y	1 5/8"-1 3/4"	3"	OVL
<b>MUSTANG II 2.3L</b>											
74-80	2.3L	H8401	H8401-B	H8401-1	Ⓢ	56, 70, 71	Y	Y	1 5/8"-1 3/4"	3"	OVL
74-80	2.3L	H8402	H8402-B	H8402-1	Ⓢ	56, 72, 188	Y	Y	1 5/8"-1 3/4"	3"	OVL
<b>STREET STOCK HEADERS</b>											
<b>CHEVELLE, MONTE CARLO, GRAND PRIX, CUTLASS, REGAL</b>											
78-86	265-400	H8044	H8044-B	H8044-1	Ⓢ	17, 65, 66	Y	N	1 5/8"	3"	RD
78-86	265-400	H8038	H8038-B	H8038-1	Ⓢ	17, 65, 66	Y	N	1 3/4"	3 1/2"	REC
<b>LATE MODEL CONVENTIONAL CROSSOVER HEADERS</b>											
<b>BEMCO, HAMKE, HOWE, LEFTHANDER AND PORT CITY CHASSIS</b>											
CHEVY	265-400	H8045	H8045-B	H8045-1	Ⓢ	17	Y	Y	1 3/4"	3 1/2"	REC
<b>IMCA HEADERS</b>											
<b>CHEVROLET ENGINES</b>											
ALL	265-400	H8020	H8020-B	H8020-1	Ⓢ	17, 43, 44	Y	Y	1 3/4"	3 1/2"	REC
ALL	265-400	H8022	H8022-B	H8022-1	Ⓢ	17, 56, 57	Y	Y	1 5/8"-1 3/4"	3"	RD
<b>FORD ENGINES</b>											
ALL	289-351W	H8423	H8423-B	H8423-1	Ⓢ	43, 44, 55	Y	Y	1 5/8"	3"	OVL

## REPLACEMENT COLLECTORS

Often times exposed collectors become damaged as a result of relentless competition. These replacement raw steel collectors for our popular H8022 header simplify repairs.

Driver side 60° turnout

H7640

Passenger side 90° turnout

H7641



## FOOTNOTES

<p>17 Fits most angle plug heads</p> <p>32 Fits only when a 62-67 type intake manifold is used</p> <p>43 Exits toward front tire</p> <p>44 Can be run upside down to gain clearance but will require relocating water temperature sending unit</p> <p>55 Fits GT40 "P" head</p>	<p>56 Stepped pipe design increases low end torque without sacrificing higher RPM performance</p> <p>57 Slip on style 90 and 45 degree collectors are adjustable for tuning and footbox location</p> <p>65 Fits with solid side and rear mounts</p> <p>66 Does not clear stock manual clutch linkage ball located behind the #7 cylinder</p>	<p>70 Fits production chassis exiting under the car</p> <p>71 Does not clear 2.0L stock motor mount</p> <p>72 Goes through firewall if used on a production Pinto/Mustang II chassis.</p> <p>75 Fuel injected engines only</p> <p>103 Jaguar exhaust systems available separately.</p> <p>188 Fits "Pro Four" tube chassis style</p>
---	--	--



## SIDE EXHAUST

### SHIELDED SIDE PIPE

Give your vehicle that custom look with our classic shielded side exhaust system. Large inlet and outlet pipes with low back pressure six-sided louvered core mufflers guarantee performance and create that distinctive power tone. Complete installation flexibility is built in with the full 360° rotation feature on both inlet and outlet pipes. Includes mounting hardware.



PART NO.	INLET DIAMETER	OUTLET DIAMETER	LENGTH	REPLACEMENT PARTS			
				MUFFLER	INLET PIPE	OUTLET PIPE	SHIELD
<b>SHIELDED SIDE PIPES</b>							
H1050	2"-2 1/2"	3"	50"	H3950	H7434	H7432	H7452
H1060	2"-2 1/2"	3"	60"	H3952	H7434	H7432	H7453
H1070	2"-2 1/2"	3"	70"	H3954	H7434	H7432	H7454
H1080	2"-2 1/2"	3"	80"	H3954	H7435	H7433	H7454

### SIDE PIPE HOOK-UP KIT

Now there is an easy way for you to hook-up your side pipe exhaust system. Our kit works with 2" up to 2 1/2" inlet sizes and comes with two 90° and two 180° bends with required saddle clamps. Some minor fabrication and welding is required.

**H7402**

See Page 28

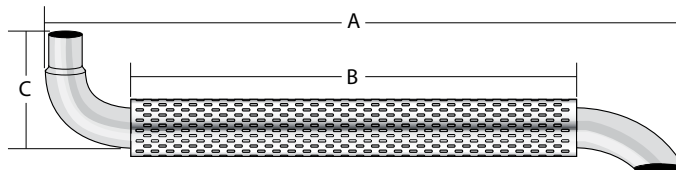

PART NO.	DIM. A	DIM. B	DIM. C	INLET	OUTLET
H1050	50"	36"	6 1/2"	2"-2 1/2"	3"
H1060	60"	46"	6 1/2"	2"-2 1/2"	3"
H1070	70"	56"	6 1/2"	2"-2 1/2"	3"
H1080	80"	56"	6 1/2"	2"-2 1/2"	3"

### SHIELDED SIDE TUBE TURNOUT

This shielded turnout features a classic slotted one-piece shield that will give your rod a great custom look and provide burn protection when exiting the car. Its built-in six sided louvered muffler provides excellent sound control without robbing horsepower. Large 3 1/2" diameter inlet make this turnout the perfect mate to any of our roadster headers.



PART NO.	INLET DIAMETER	CASE DIAMETER	LENGTH
<b>SHIELDED SIDE TUBE TURNOUT</b>			
H3824	3 1/2"	3 1/2"	26"

### SIDE TUBE TURNOUTS

Side tube turnouts are designed primarily for roadster style headers. Each turnout is constructed from 3 1/2" tube and available with or without built-in six sided louvered mufflers. Turnouts provide the perfect finishing touch to many custom exhaust applications.



RAW STEEL PART NO.	HI-TEMP BLACK COATING	COATED PART NO.	CHROME PART NO.	INLET DIAMETER	LENGTH
--------------------	-----------------------	-----------------	-----------------	----------------	--------

#### SIDE TUBE TURNOUTS WITHOUT MUFFLER

H3817	H3817-B	H3817-1	H3816	3 1/2"	20"
H3819	H3819-B	H3819-1	H3820	3 1/2"	26"

#### SIDE TUBE TURNOUTS WITH MUFFLER

H3812	H3812-B	H3812-1	H3818	3 1/2"	20"
H3821	H3821-B	H3821-1	H3822	3 1/2"	26"





**LAKE PIPE '4'**

Get the look of an expensive tuned header side pipe at a fraction of the cost. Chrome Lake Pipe '4' kits connect to headers or a stock exhaust system with one functioning inlet tube and 3 dress-up tubes. Side pipes have built in "HI-FLO" six sided louvered cored mufflers which absorb sound not horsepower. Fully welded brackets allow for easy installation. The length is measured from the first inlet tube to the tip of the side pipe.

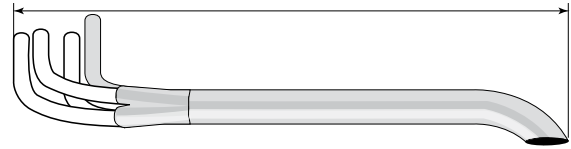

PART NO.	INLET DIAMETER	OUTLET DIAMETER	LENGTH	REPLACEMENT INLET PIPE
<b>LAKE PIPE '4'</b>				
H1165	2"	3 1/2"	63"	
H1170	1 3/4"	3"	73"	H7400
H1175	2"	3 1/2"	73"	
H1180	1 3/4"	3"	83"	H7400
H1185	2"	3 1/2"	83"	

**LOW-LINE LAKE PIPES**

The look is back and you can have it with our triple, single and slant style lake pipes. These pipes do not incorporate any silencing materials and are recommended for non-functional use only. Available in three different lengths. The pipe kits come with chromed pipe plugs (except the slant style).

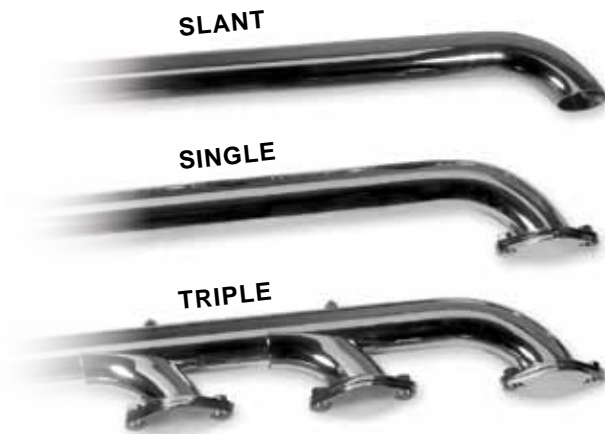

PART NO.	INLET DIAMETER	OUTLET DIAMETER	LENGTH
<b>SLANT STYLE LOW-LINE LAKE PIPES</b>			
H1260	2"	2"	60"
H1270	2"	2"	70"
H1280	2"	2"	80"
H1381	1 3/4"	1 3/4"	81"
H1384	1 3/4"	1 3/4"	84"
<b>SINGLE STYLE LOW-LINE LAKE PIPES</b>			
H1263	2"	2"	60"
H1273	2"	2"	70"
H1283	2"	2"	80"
<b>TRIPLE STYLE LOW-LINE LAKE PIPES</b>			
H1264	2"	2"	60"
H1274	2"	2"	70"
H1284	2"	2"	80"

**LAKE PIPE PLUG KIT**

Create the custom look with a Lake Plug kit. Comes complete with caps and hardware. Caps are also available separately. Sold in pairs.



Lake pipe plug kit	H1285
Lake pipe cap kit	H1286

**CHROME CLAMPS**

Why bolt up your new side pipe exhaust system with those rusty old clamps you've got laying around. Finish off your exhaust system with these stylish chrome clamps. Available in two sizes. Sold individually.



1 3/4" clamps	HPC175
2" clamps	HPC200



## MUFFLERS

### VARAFLOW® TUNABLE MUFFLER

This new muffler features SFI Technology and utilizes an electric motor and valve assembly which allows the user to adjust the sound of their exhaust, while they drive. SFI stands for Sound Flow Inversion, Patriot's proprietary valve and baffle design which allows the user to redirect the flow of the exhaust to instantly change the volume and tone. The primary purpose for this design is not only to allow the driver to get the exact sound they are looking for but to also tune out annoying drones when driving down the highway and then have the option to make more noise on "Cruise Night." At idle the difference between open and closed positions is approximately 5 dB. At 5000 RPM the difference is closer to 15 dB. For reference, an increase of 10 dB. in sound is two times louder and an increase of 20 dB. is four times louder.

The VaraFlow Muffler is made from corrosion resistant Stainless Steel and polished to a high luster. VaraFlow mufflers come complete with a simple two wire hookup in a shielded harness, illuminated control switch and wiring instructions for single or dual switch installations. Sold individually.

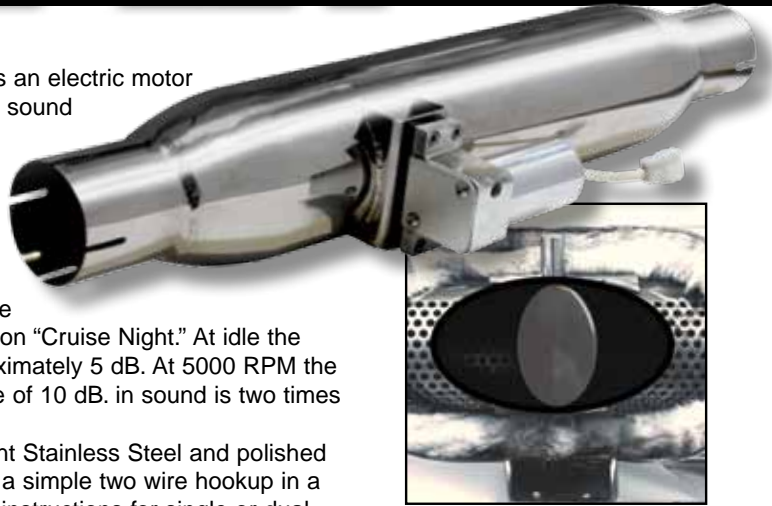

The world's oldest performance muffler is now available for that "resto-rod" or your 1950's custom. Get the muffler your dad used to impress his friends, and yes, it's still guaranteed not to blow out or leak. Double end cap construction and 3 1/2" hammertone finished cases assure the original Smithy look.



### STAINLESS MUFFLERS

Perfect for the ultimate street rod, our 304 polished stainless steel glasspack muffler features our six sided louvered core for improved noise absorption. Only long strand sound absorption material is used for increased service life.



### HI-FLO GLASSPACKS

Heavy steel core design has six rows of louvers for reduced restriction and better sound absorption. Long strand sound absorption material is used for increased muffler life.



PART NO.	INLET/OUTLET DIAMETER	CASE DIAMETER	LENGTH	UNIT OF MEASURE
<b>VARAFLOW TUNABLE MUFFLER</b>				
H3200	2 1/2"	4"	24"	each

PART NO.	INLET/OUTLET DIAMETER	CORE DIAMETER	CASE LENGTH	CASE DIAMETER
<b>SMITHY'S MUFFLERS</b>				
H3010	2"	1 3/4"	22"	3 1/2"
H3011	2"	1 3/4"	26"	3 1/2"
H3012	2"	1 3/4"	30"	3 1/2"
H3013	2 1/4"	2 1/4"	22"	3 1/2"
H3014	2 1/4"	2 1/4"	26"	3 1/2"
H3015	2 1/4"	2 1/4"	30"	3 1/2"
H3016	2 1/2"	2 1/2"	22"	3 1/2"
H3017	2 1/2"	2 1/2"	26"	3 1/2"
H3018	2 1/2"	2 1/2"	30"	3 1/2"

PART NO.	INLET/OUTLET DIAMETER	CORE DIAMETER	CASE LENGTH	CASE DIAMETER
<b>STAINLESS MUFFLERS</b>				
H3348	2"	1 3/4"	22"	3"
H3349	2"	1 3/4"	26"	3"

PART NO.	INLET/OUTLET DIAMETER	CORE DIAMETER	CASE LENGTH	CASE DIAMETER
<b>HI-FLO GLASSPACK MUFFLERS</b>				
H3543	1 3/4"	1 3/4"	18"	3 1/2"
H3344	1 3/4"	1 3/4"	22"	3"
H3544	1 3/4"	1 3/4"	22"	3 1/2"
H3345	1 3/4"	1 3/4"	24"	3"
H3453	2"	2"	18"	4"
H3554	2"	2"	22"	3 1/2"
H3456	2"	2"	26"	4"
H3558	2"	2"	36"	3 1/2"



**HI-FLO HEADER MOUNT GLASSPACKS**

Heavy steel core design has six rows of louvers for reduced restriction and better sound absorption. Long strand sound absorption material is used for increased muffler life. Accommodates common 3-bolt header flanges.



PART NO.	COLLECTOR DIAMETER	CORE DIAMETER	CASE LENGTH	CASE DIAMETER
<b>HI-FLO HEADER STYLE</b>				
H3800	2 1/2"	2"	32 1/2"	3 1/2"
H3801	3"	2"	34"	3 1/2"
H3805	3 1/2"	2"	35"	3 1/2"

**UNIVERSAL MINI MUFFLER**

Reduce exhaust noise without a bulky exhaust system. Simple "screw in place" installation makes this muffler incredibly versatile.



PART NO.	CORE DIAMETER	LENGTH	CASE DIAMETER
<b>MINI MUFFLER</b>			
H3133	1"	12"	1 1/2"
H3121	1 1/4"	12"	1 5/8"
H3132	1"	8"	1 1/2"
H3110	1"	8"	1 3/8"
H3120	1 1/4"	8"	1 5/8"

**TWO STROKE SILENCER**

Tone down the exhaust note of your 2-cycle engine. Simple "slip in" design allows this silencer to fit most expansion chambers.



<b>TWO STROKE SILENCERS</b>			
H2970	1"	8"	1 1/2"
H2971	1 1/4"	8"	2"

**STANDARD MUFFLER INSERT**

Our heavy duty six-sided louvered core is wrapped with hi-temp fiberglass packing for long life. Designed to slip inside turnouts, side pipes or extensions.



PART NO.	TUBE DIAMETER	LENGTH
<b>STANDARD INSERT</b>		
H3842	3 1/2"	7"
H3840	3 1/2"	12 1/2"

**AUGER INSERT**

Our auger style provides excellent sound control without the fiberglass packing.



<b>AUGER INSERT</b>		
H3844	3"	11"
H3843	3 1/2"	11"



## EXHAUST TIPS

### BELLFLOWER TIP

The Bellflower design permits custom fabrication of the exhaust pipe. These tips are very popular on customized 50's and 60's rods.



### DRIVE SHAFT TIP

The Drive Shaft tip has a rolled edge just like our bellflower tip but is a straight tip with no bend.



### DUMP TUBE

Our chrome "Dump" tube has a straight through design without any silencing material and is recommended for non-functional use only. Dump tube measures 16" in length and has a 2" inlet and outlet. Includes cap.



### STREET ROD MEGAPHONE

Megaphones can be used to give any street rod that custom look. Available in raw steel or chrome finishes and a wide assortment of inlet and outlet diameters.



### TURN DOWN TIP

Specifically designed for motorcycle applications with each tip featuring an integral clamp fitting and a fine polished chrome finish.



### STREET ROD TIPS

PART NO.	INLET DIAMETER	OUTLET DIAMETER	LENGTH
<b>BELLFLOWER TIP</b>			
H1530	1 7/8"	2 1/2"	28"
H1531	1 7/8"	2 1/2"	32"
H1532	1 7/8"	2 1/2"	39"
<b>DRIVESHAFT TIP</b>			
H1570	2 1/2"	2 1/2"	18"
H1571	2 1/2"	2 1/2"	24"
H1572	2 1/2"	2 1/2"	30"
<b>DUMP TUBE</b>			
H1620	2"	2"	16"
<b>MEGAPHONE</b>			
H7328 (chrome)	2"	4"	12"
H7324 (chrome)	2"	4"	24"
H7321 (chrome)	2 1/4"	3 3/4"	17 3/4"
H7329 (raw steel)	1 5/8"	3 1/2"	30"
H7331 (raw steel)	1 5/8"	4"	30"
H7327 (raw steel)	2"	4"	12"
H7323 (raw steel)	2"	4"	24"
H7320 (raw steel)	2 1/4"	3 3/4"	17 3/4"
<b>TURN DOWN TIP</b>			
H2963	1 1/2"	1 1/2"	13"
H2964	1 5/8"	1 5/8"	13"
H2965	1 3/4"	1 3/4"	13"

### UNIVERSAL TIPS

PART NO.	INLET DIAMETER	OUTLET DIAMETER	LENGTH	STYLE
<b>CURVE DOWN FLARE TIP</b>				
H1542	1 7/8"		12"	
H1543	2"		12"	
H1546	2 1/2"		12"	
<b>ECHO CAN</b>				
H1533	2"	3"	12"	
H1534	2"	3 1/2"	12"	
H1535	2"	3 1/2"	18"	
<b>FISHTAIL STYLE</b>				
H2950	1 7/8"		8"	
<b>PENCIL TIP</b>				
H1607	2 1/8"	2 1/8"	9"	
<b>SLASH CUT TIP</b>				
H1505	2 1/2"		9"	
<b>STRAIGHT FLARE TIP</b>				
H1593	2 1/4"		9"	



## EXHAUST ACCESSORIES

### COLLECTOR REDUCERS

Our collector reducers are zinc plated to minimize corrosion while providing a weldable finish. Kits include two reducers, gaskets and flange bolts.



PART NO.	COLLECTOR DIA. (A)	OUTLET DIA. (C)	LENGTH (D)	THICKNESS (B)
<b>COLLECTOR REDUCERS</b>				
H7248	2 1/2"	2"	1 3/4"	4 Gauge
H7250	2 1/2"	2"	5"	4 Gauge
H7229	2 1/2"	2 1/4"	1 1/2"	4 Gauge
H7242	2 1/2"	2 1/2"	5"	4 Gauge
H7239	2 1/2"	2 1/2"	5"	5/16
H7251	3"	2 1/4"	5"	4 Gauge
H7243	3"	2 1/2"	5"	4 Gauge
H7238	3"	2 1/2"	5"	5/16
H7244	3"	3"	5"	4 Gauge
H7237	3"	3"	5"	5/16
H7252	3 1/2"	2 1/2"	5"	4 Gauge
H7236	3 1/2"	2 1/2"	5"	3/8
H7245	3 1/2"	3"	5"	4 Gauge
H7235	3 1/2"	3"	5"	3/8
H7246	3 1/2"	3 1/2"	5"	4 Gauge

#### DOMESTYLE REDUCER FOR H8019

H7247	2 1/2"	2 1/4"	1 3/4"	4 Gauge
-------	--------	--------	--------	---------

#### REPLACEMENT REDUCER FOR H8014

H7249	2 1/2"	2 1/2"	4"	4 Gauge
-------	--------	--------	----	---------

#### OXYGEN SENSOR REDUCERS

H7232	2 1/2"	2 1/4"	5"	5/16
H7233	3"	2 1/2"	5"	5/16

#### OXYGEN SENSOR FITTING

H7231	Universal weld-on 18mm thread sold individually			
-------	---	--	--	--



### HEADER BRACKETS

Simplify your header installation with our quality brackets. These brackets are made from rigid steel and plated to resist corrosion.

PART NO.	DESCRIPTION
----------	-------------

#### GM ALTERNATOR BRACKETS

H7606	Mounting bracket left side only (use with H7607)
H7607	Adapter bracket (use with H7606)

#### GM A/C BRACKETS

H7608	Chevy Small Block left side
-------	-----------------------------

#### FORD POWER STEERING BRACKET

H7609	Cars with external slave cylinder
-------	-----------------------------------



### TURNOUTS AND SLIP CONNECTORS

PART NO.	INLET DIAMETER	OUTLET DIAMETER	LENGTH	UNIT OF MEASURE
<b>UNIVERSAL TURNOUTS</b>				
H3813	3"	3"	9"	pair
H3814	3"	3"	24"	pair
H3815	3 1/2"	3 1/2"	9"	pair
H3817	3 1/2"	3 1/2"	20"	pair

#### SLIP CONNECTORS

H7621	1 5/8"	1 5/8"	3"	each
H7624	1 3/4"	1 3/4"	3"	each
H7628	2"	2"	3 1/2"	each
H7631	2 1/4"	2 1/4"	4"	each
H7633	3"	3"	3"	each
H7635	4"	4"	4 1/2"	each





## EXHAUST ACCESSORIES

### EXHAUST HARDWARE

Our complete line of exhaust hardware will help complete any exhaust installation. From rubber grommets to custom chrome circle clamps for Lake pipes, we have it.

PART NO. DESCRIPTION

#### UNIVERSAL FLAT HANGER BRACKETS

H7602	6" long flat hanger bracket
H7603	7" long flat hanger bracket
H7604	9" long flat hanger bracket
H7613	7" long "L" hanger bracket



#### CIRCLE CLAMPS

HPC175	Chrome circle clamp 1 3/4" diameter
HPC200	Chrome circle clamp 2" diameter



#### U-CLAMPS

H7172	U-clamp 1 1/2" diameter
H7173	U-clamp 1 5/8" diameter
H7174	U-clamp 1 3/4" diameter
H7175	U-clamp 1 7/8" diameter
H7176	U-clamp 2" diameter
H7177	U-clamp 2 1/8" diameter
H7179	U-clamp 2 1/4" diameter
H7180	U-clamp 2 1/2" diameter
H7181	U-clamp 3" diameter



#### GROMMETS

H7240	Universal male style
H7241	Universal female style



### SIDE PIPE HOOK-UP KIT

Now there is an easy way for you to hook-up your side pipe exhaust system. Our kit works with 2" up to 2 1/2" inlet sizes and comes with two 90° and two 180° 400 series stainless steel bends with required saddle clamps. Some minor fabrication and welding may be required.

H7402



### EXHAUST CUT-OUT KITS

Easy to install cut-outs permit quick bypassing of your exhaust system for maximum power in racing conditions. Cut-outs have bright zinc plated to minimize corrosion. Kits come with all necessary mounting hardware. Some fabrication may be required but no welding is needed.

PART NO. DESCRIPTION TUBE DIAMETER UNIT OF MEASURE

#### EXHAUST CUT-OUT KITS

<b>NEW</b>	H1128	Cut-out kit	2 1/4"	Pair
<b>NEW</b>	H1129	Cut-out kit	2 1/4"	Single
	H1130	Cut-out kit	2 1/2"	Pair
	H1131	Cut-out kit	2 1/2"	Single
	H1132	Cut-out kit	3"	Pair
	H1133	Cut-out kit	3"	Single
	H1134	Cut-out kit	3 1/2"	Pair
	H1135	Cut-out kit	3 1/2"	Single



### HEADER BOLTS

Our header bolts feature a reduced head for easier installation and are bright zinc plated to minimize corrosion.

DESCRIPTION 12 QTY. 16 QTY. 500 QTY.

	5/16-18 x 3/4	H7976		
	5/16-18 x 1	H7977		
<b>NEW</b>	8MM x 1.25 x 26MM	H7978		
<b>NEW</b>	8MM x 1.25 x 30MM	H7979		
<b>NEW</b>	10MM x 1.25 x 22MM	H7980		
	3/8-16 x 3/4	H7970	H7971	H7972
	3/8-16 x 1	H7973	H7974	H7975



3/8-16 X 3/4"



3/8-16 X 1"



## FORMED COLLECTORS & FLANGES

### FORMED COLLECTORS

Doug's mild steel (1010) formed collectors provide a smooth transition point for superior exhaust scavenging. Choose from a variety of primary tube and collector sizes.

PART NO.	PRI. TUBE DIAMETER	COLLECTOR DIAMETER	LENGTH	TUBING GAUGE	UNIT OF MEASURE
<b>4 INTO 1 COLLECTORS</b>					
H7678	1 1/2"	2 1/2"	6"	16	pair
H7668	1 1/2"	2 1/2"	9"	16	pair
H7669	1 1/2"	3"	9"	16	pair
H7679	1 1/2"	3 1/2"	10"	16	pair
H7671	1 5/8"	2 1/2"	10"	16	pair
H7670	1 5/8"	3"	10"	16	pair
H7680	1 5/8"	3 1/2"	10"	16	pair
H7672	1 3/4"	3"	10"	16	pair
H7682	1 3/4"	3 1/2"	10"	16	pair
H7674	1 7/8"	3"	10"	16	pair
H7684	1 7/8"	3 1/2"	10"	16	pair
H7686	2"	3 1/2"	10"	16	pair
H7681	2"	4"	10"	16	pair
H7688	2 1/8"	3 1/2"	10"	16	pair
H7689	2 1/8"	4"	12"	16	pair
H7685	2 1/4"	3 1/2"	10"	16	pair
H7690	2 1/4"	4"	10"	16	pair
H7693	2 1/4"	4 1/2"	10"	16	pair
H7696	2 1/2"	5"	10"	16	pair
<b>SLIP-ON 4 INTO 1 COLLECTORS</b>					
H7691	2 1/4"	4"	12"	16	pair
H7695	2 3/8"	4 1/2"	12"	16	pair
H7697	2 1/2"	5"	12"	16	pair
<b>2 INTO 1 COLLECTORS</b>					
H7659	1 5/8"	2"	6 1/2"	16	each
H7660	1 5/8"	2 1/2"	6 1/2"	16	each
H7661	1 3/4"	2"	6 1/2"	16	each
H7662	1 3/4"	2 1/8"	6 1/2"	16	each
H7663	1 3/4"	2 1/4"	6 1/2"	16	each
H7664	2"	2 1/2"	6 1/2"	16	each
H7665	2 1/2"	3"	6 1/2"	16	each
H7666	2 1/2"	3 1/2"	6 1/2"	16	each
H7667	2 1/2"	4"	6 1/2"	16	each

### COLLECTOR FLANGE KITS

Flange kits include two flanges, gaskets and flange bolts. Round collector flanges kits include two block off plates and two flanges.

PART NO.	DESCRIPTION	COLLECTOR DIAMETER (A)	FLANGE THICKNESS (B)
H7257	2 bolt	2"	4 Gauge
H7265	2 bolt	2 1/2"	4 Gauge
H7258	3 bolt	2"	4 Gauge
H7259	3 bolt	2 1/2"	4 Gauge
H7230	3 bolt Stainless	2 1/2"	5/16"
H7253	3 bolt	2 1/2"	5/16"
H7254	3 bolt	2 1/2"	3/8"
H7260	3 bolt	3"	4 Gauge
H7268	3 bolt	3"	3/8"
H7261	3 bolt	3 1/2"	4 Gauge
H7269	3 bolt	3 1/2"	3/8"
H7266	4 bolt round	3 1/2"	5/16"
H7267	4 bolt round	4"	5/16"



H7664



H7697



## HEADER FLANGE KITS

### HEADER FLANGE KITS

Patriot precision machined header flange kits are available for many popular engine families. Header flange kits come complete with gaskets and header bolts on most applications. Choose from our heavy duty 3/8" supplied with our premium 1100° F gaskets or less expensive lighter weight 5/16" flanges.

PART NO.	ENGINE / DESCRIPTION	TUBE DIAMETER	PORT SHAPE
<b>3/8" FLANGE KITS</b>			
<b>CADILLAC</b>			
H7830	425, 500	1 7/8	SQ
<b>CHEVROLET</b>			
H7831	265-400	1 5/8"	RD
H7863	265-400	1 5/8"	OVL
H7832	265-400	1 3/4"	REC
H7834	348, 409	2"	REC
H7899	396-502	1 3/4" - 2"	SAP
H7886	396-502	2 1/8"	RD
H7887	396-502	2 1/4"	RD
H7888	396-502	2 3/8"	RD
H7889	396-502	2 1/2"	RD
H7898	572	2" - 2 1/8"	D-port
H7893	LS1-LS6	1 5/8" - 1 3/4"	RD
<b>NEW</b> H7813	LS1-LS6	1 7/8"	RD
<b>NEW</b> H7807	LS7	1 7/8"	D-port
<b>CHRYSLER</b>			
H7835	273-360	1 5/8" - 1 3/4"	SAP
<b>NEW</b> H7812	5.7/6.1/6.4L Hemi	1 3/4"	SAP
H7838	383-440 excluding Hemi	1 3/4"	REC
H7828	383-440 excluding Hemi	2"	REC
H7837	331-392 Hemi	2"	RD
H7840	426 Hemi	2" - 2 1/4"	SQ
<b>FORD</b>			
H7841	260-351W	1 5/8" - 3/4"	REC
H7846	351W (World Product head)	1 3/4"	REC
<b>NEW</b> H7808	4.6L 2V	1 5/8"	SAP
<b>NEW</b> H7809	4.6L 3V	1 5/8"	SAP
<b>NEW</b> H7810	4.6L 4V	1 5/8"	SAP
H7801	5.0L Coyote	1 7/8"	SAP
<b>NEW</b> H7811	5.4/5.8L 4V	1 3/4"	SAP
H7844	351C (2BBL Heads), 351-400M	1 3/4"	OVL
H7845	Boss 302, 351C (4BBL Heads)	2"	SAP
H7847	390-428 (8-bolt truck)	1 3/4"	REC
H7848	390-428 (8-bolt car)	2" - 2 1/8"	REC
H7829	390-428 (16-bolt car)	2" - 2 1/8"	REC
H7849	429-460	1 3/4"	OVL
H7850	429-460	2"	OVL
H7851	460 (fuel injection)	1 3/4"	OVL / D
<b>OLDSMOBILE</b>			
H7852	403-455	1 3/4"	REC
<b>PONTIAC</b>			
H7853	326-455 (see note below)	1 7/8"	RD
H7859	326-455 (see note below)	2"	RD
H7854	326-455	1 5/8" - 1 3/4"	D-port
<b>VOLVO</b>			
H7802	B18-B20 1/2" thick flange	1 1/2"	REC

PART NO.	ENGINE / DESCRIPTION	TUBE DIAMETER	PORT SHAPE
<b>5/16" FLANGE KITS</b>			
<b>BUICK</b>			
H7860	401-425 (Nailhead)	1 5/8"	SAP
<b>CADILLAC</b>			
H7884	425, 500	1 7/8	SQ
<b>CHEVROLET</b>			
H7883	4.3L V6	1 1/2"	RD
H7864	265-400	1 5/8"	RD
H7825	265-400	1 5/8"	OVL
H7861	265-400 (304 Stainless)	1 5/8"	OVL
H7894	265-400	1 3/4"	REC
H7896	265-400 Brodix	1 3/4"	RD
H7895	265-400 Brodix	1 7/8" - 2"	RD
H7833	265-400 (outer flange)	1 7/8" - 2"	RD
H7800	265-400 (inner flange)	N/A	SAP
H7872	348, 409	1 3/4"	REC
H7892	LS1-LS6	1 5/8" - 1 3/4"	RD
<b>CHRYSLER</b>			
H7880	273-360	1 5/8" - 1 3/4"	SAP
H7890	383-440 excluding Hemi	1 3/4"	REC
H7897	383-440 excluding Hemi	2"	REC
<b>FORD</b>			
H7804	2.3L 4 cylinder	1 5/8"	RD
H7805	223 6 cylinder	1 1/2"	REC
H7842	260-351W	1 1/2"	REC
H7870	260-351W	1 5/8" - 1 3/4"	OVL
H7869	272-312 Y	1 1/2"	SQ
H7873	Flathead	1 3/4"	RD
H7806	351C (2BBL Heads), 351-400M	1 3/4"	OVL
H7881	Boss 302, 351C (4BBL Heads)	2"	SAP
H7855	390-428 (8-bolt truck)	1 3/4"	REC
H7871	429-460	2"	OVL
<b>JAGUAR</b>			
H7803	3.8-4.2L	1 5/8"	REC
<b>PONTIAC</b>			
H7882	326-455	1 5/8" - 1 3/4"	D-port



H7853 and H7859 flange kits fit Edelbrock Performer, RAM-Air, Super Duty and H.O. heads only





## GASKETS

### HEADER FLANGE GASKETS

Our gaskets are made from thick, tear resistant material and are specifically cut to match Patriot header flanges. Make sure you get the perfect match by ordering our replacement gaskets.

PART NO.	ENGINE	PORT SHAPE	UNIT OF MEASURE	GASKET STYLE	
<b>BUICK</b>					
H7584	401-425	REC	pair		
<b>CADILLAC</b>					
H7573	425, 500	SQ	pair		
<b>CHEVROLET</b>					
H7594	4.3L V6	OVL	pair		
H7585	283-400	OVL	pair		
H7586	283-400	RD	pair		
H7553	283-400 (BRODIX)	Spread Port	pair		
H7588	LS1-LS6	RD	pair		
H7582	348-409	SAP	pair		
H7587	396-502	REC	pair		
HG9303LG	396-502 2 1/8" - 2 1/2"	RD	pair		
<b>FORD</b>					
H7506	2.3L 4 cylinder	RD	each		
H7597	223 6 cylinder	SQ	each		
H7557	Flathead (individual gaskets)	RD	set		
H7559	Flathead	RD	pair		
H7589	272-312 Y block	SQ	pair		
H7518	260-351W	REC	pair		
H7590	260-351W 1 5/8" - 1 3/4"	OVL	pair		
H7592	Boss 302, 351C (4BBL Heads)	SAP	pair		
H7596	351C (2BBL Heads), 351-400M	OVL	pair		
H7554	352-428 FE (8-bolt truck)	REC	pair		
H7591	429-460	OVL	pair		
<b>JAGUAR</b>					
H7555	3.8-4.2L	REC	pair		
<b>MOPAR</b>					
H7593	318-360	SAP	pair		
H7574	331-392 HEMI	RD	pair		
H7595	383-440 Excluding Hemi	REC	pair		
<b>OLDSMOBILE</b>					
H7572	350-455	REC	pair		
<b>PONTIAC</b>					
H7581	326-455	SAP	pair		
<b>VOLVO</b>					
H7583	1800cc	REC	each		

PART NO.	DESCRIPTION	COLLECTOR DIAMETER	UNIT OF MEASURE
<b>COLLECTOR GASKETS</b>			
H7953	two bolt collector gasket	2"	pair
H7952	two bolt collector gasket	2 1/2"	pair
H7938	three bolt collector gasket	2 1/2"	pair
H7947	three bolt collector gasket	3"	pair
H7951	three bolt collector gasket	3 1/2"	pair
H7546	sq four bolt collector gasket	2 1/2"	pair
H7957	rd four bolt collector gasket	3 1/2"	pair
H7998	rd four bolt collector gasket	4"	pair

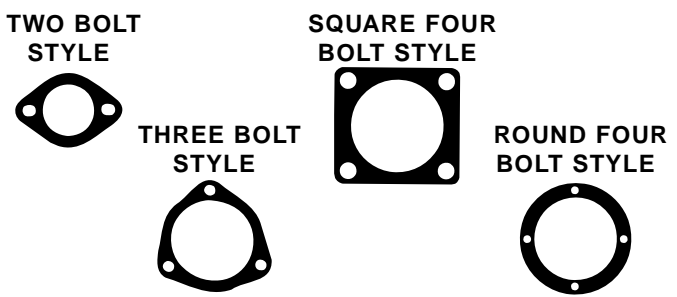



## J BENDS

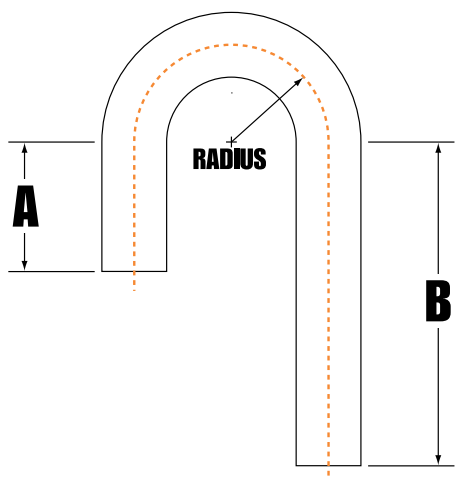

### MILD STEEL MANDREL BENDS (1010)

Our mild steel mandrel bends are available in many combinations of radius, tube diameter and length to suit professional header builders, custom muffler shops and do-it-yourselfers alike. All our bends are made on the industry's most up to date mandrel bending machines to ensure smooth wrinkle-free bends with no crimping.

### ALUMINIZED MANDREL BENDS (A787)

Aluminized tubing has become increasingly popular in exhaust system fabrication as a lower cost alternative to stainless steel. We offer a complete assortment of bends in all the popular exhaust system sizes.

### 304 STAINLESS STEEL MANDREL BENDS (A269)

Our 304 stainless steel mandrel bends combine excellent physical properties with a remarkable resistance to corrosive agents found in automotive exhaust emissions. 304 material is the most cost-effective grade of nonmagnetic stainless steel for high strength racing applications or custom street machine exhaust systems.



#### LEG LENGTHS

PART NO.	GAUGE	TUBE DIAMETER	RADIUS	A	B
----------	-------	---------------	--------	---	---

### J BENDS

#### 18 GAUGE MILD STEEL (1010)

H7013	18	1 1/2"	2"	6"	15"
H7018	18	1 5/8"	2"	6"	15"
H7002	18	1 5/8"	4"	6"	15"
H7020	18	1 3/4"	2"	6"	15"
H7022	18	1 3/4"	2 1/2"	6"	15"
H7028	18	1 7/8"	2 1/2"	6"	15"
H7029	18	1 7/8"	3"	6"	15"
H7036	18	2"	3"	6"	15"
H7041	18	2"	4"	6"	15"
H7043	18	2 1/8"	3"	6"	15"
H7001	18	2 1/8"	3 1/2"	6"	15"
H7049	18	2 1/4"	3 1/2"	6"	15"
H7075	18	2 1/4"	4"	6"	15"
H7078	18	2 3/8"	3"	6"	15"
H7054	18	2 1/2"	3"	6"	15"
H7076	18	2 1/2"	4"	6"	15"

#### 16 GAUGE MILD STEEL (1010)

H7008	16	1 1/2"	2"	6"	15"
H7019	16	1 5/8"	2"	6"	15"
H7003	16	1 5/8"	4"	6"	15"
H7021	16	1 3/4"	2"	6"	15"
H7032	16	1 7/8"	2 1/2"	6"	15"
H7042	16	2"	3"	6"	15"
H7044	16	2 1/8"	3"	6"	15"
H7048	16	2 1/8"	4"	6"	15"
H7053	16	2 1/4"	3 1/2"	6"	15"
H7059	16	2 1/2"	3"	6"	15"
H7058	16	2 1/2"	4"	6"	15"

#### ALUMINIZED (A787)

H7080	16	2 1/4"	3 1/2"	6"	15"
H7083	16	2 1/2"	4"	6"	15"

#### 304 STAINLESS STEEL (A269)

H6900	18	1 1/4"	2 1/4"	6"	12"
H6901	18	1 3/8"	2 1/2"	6"	12"
H6902	18	1 1/2"	2"	6"	12"
H6903	18	1 1/2"	2 1/2"	6"	12"
H6904	18	1 1/2"	3"	6"	12"
H6905	18	1 5/8"	2"	6"	12"
H6906	18	1 5/8"	2 1/2"	6"	12"
H6907	18	1 5/8"	3"	6"	12"
H6908	18	1 3/4"	2"	6"	12"
H6909	18	1 3/4"	2 1/2"	6"	12"
H6910	18	1 3/4"	3"	6"	12"
H6911	18	1 3/4"	4"	6"	12"
H6912	18	1 7/8"	2 1/2"	6"	12"
H6913	18	1 7/8"	3"	6"	12"
H6914	18	1 7/8"	4"	6"	12"
H6915	18	2"	3"	6"	12"
H6956	16	2"	3"	6"	12"
H6916	18	2"	4"	6"	12"
H6917	18	2 1/8"	3"	6"	12"
H6957	16	2 1/8"	3"	6"	12"
H6918	18	2 1/8"	3 1/2"	6"	12"
H6919	18	2 1/8"	4"	6"	12"
H6920	18	2 1/4"	3 1/2"	6"	12"
H6958	16	2 1/4"	3 1/2"	6"	12"
H6921	18	2 1/4"	4"	6"	12"
H6924	18	2 1/2"	4"	6"	12"



**U BENDS**

PART NO.	GAUGE	TUBE DIAMETER	RADIUS	LEG LENGTHS	
				A	B
<b>18 GAUGE MILD STEEL (1010)</b>					
H7000	18	1 1/4"	2 1/4"	6"	6"
H7006	18	1 3/8"	2 1/2"	6"	6"
H7010	18	1 1/2"	2"	6"	6"
H7011	18	1 1/2"	2 1/2"	6"	6"
H7012	18	1 1/2"	3"	6"	6"
H7016	18	1 5/8"	2 1/2"	6"	6"
H7017	18	1 5/8"	3"	6"	6"
H7014	18	1 5/8"	6"	12"	12"
H7023	18	1 3/4"	2 1/2"	6"	6"
H7024	18	1 3/4"	3"	6"	6"
H7025	18	1 3/4"	4"	6"	6"
H7026	18	1 3/4"	6"	6"	6"
H7027	18	1 3/4"	6"	12"	12"
H7030	18	1 7/8"	3"	6"	6"
H7031	18	1 7/8"	4"	6"	6"
H7033	18	1 7/8"	6"	12"	12"
H7037	18	2"	3"	6"	6"
H7038	18	2"	4"	6"	6"
H7039	18	2"	6"	6"	6"
H7040	18	2"	6"	12"	12"
H7045	18	2 1/8"	6"	12"	12"
H7073	18	2 1/4"	6"	12"	12"
H7074	18	2 1/2"	5"	12"	12"
<b>16 GAUGE MILD STEEL (1010)</b>					
H7007	16	1 1/2"	2"	6"	6"
H7015	16	1 5/8"	2 1/2"	6"	6"
H7009	16	1 5/8"	6"	12"	12"
H7068	16	1 3/4"	6"	12"	12"
H7034	16	1 7/8"	6"	12"	12"
H7064	16	2"	6"	12"	12"
H7077	16	2 1/8"	3"	6"	6"
H7046	16	2 1/8"	3 1/2"	6"	6"
H7047	16	2 1/8"	6"	12"	12"
H7050	16	2 1/4"	4"	6"	6"
H7051	16	2 1/4"	6"	6"	6"
H7052	16	2 1/4"	6"	12"	12"
H7055	16	2 1/2"	4"	6"	6"
H7057	16	2 1/2"	5"	12"	12"
H7056	16	2 1/2"	6"	6"	6"
H7060	16	3"	6"	6"	6"
H7065	16	3 1/2"	7"	6"	6"
H7066	16	4"	7"	6"	6"
<b>ALUMINIZED (A787)</b>					
H7081	16	2 1/4"	6"	12"	12"
H7084	16	2 1/2"	6"	12"	12"
H7090	16	3 1/2"	7"	12"	12"
H7093	16	4"	7"	12"	12"

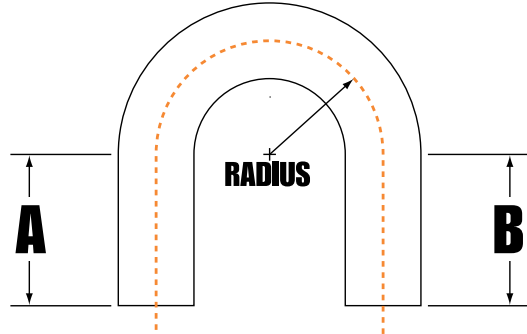

PART NO.	GAUGE	TUBE DIAMETER	RADIUS	LEG LENGTHS	
				A	B
<b>18 GAUGE 304 STAINLESS STEEL (A269)</b>					
H6925	18	1 1/4"	2 1/4"	6"	6"
H6926	18	1 3/8"	2 1/2"	6"	6"
H6927	18	1 1/2"	3"	6"	6"
H6928	18	1 5/8"	3"	6"	6"
H6929	18	1 5/8"	6"	6"	6"
H6930	18	1 3/4"	3"	6"	6"
H6931	18	1 3/4"	6"	6"	6"
H6932	18	1 7/8"	6"	6"	6"
H6933	18	2"	6"	6"	6"
H6934	18	2 1/8"	6"	6"	6"
H6935	18	2 1/4"	3 1/2"	6"	6"
H6937	18	2 1/2"	4"	6"	6"
H6939	18	2 1/2"	6"	6"	6"
H6941	18	3"	6"	6"	6"
<b>16 GAUGE 304 STAINLESS STEEL (A269)</b>					
H6936	16	2 1/4"	3 1/2"	6"	6"
H6938	16	2 1/2"	4"	6"	6"
H6940	16	2 1/2"	6"	6"	6"
H6942	16	3"	6"	6"	6"





## SPECIALITY BENDS & TUBING

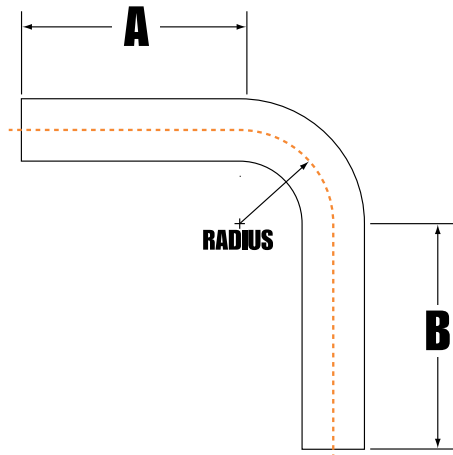

PART NO.	GAUGE	TUBE DIAMETER	RADIUS	LEG LENGTHS	
				A	B
<b>SPECIALITY BENDS</b>					
<b>45° BENDS 304 STAINLESS STEEL (A269)</b>					
H6950	16	2 1/4"	3 1/2"	6"	6"
H6951	16	2 1/2"	4"	6"	6"
H6952	16	3"	6"	6"	6"
<b>90° BENDS MILD STEEL (1010)</b>					
H7062	16	3"	3 1/2"	6"	12"
H7061	18	3"	3 1/2"	6"	12"
H7063	16	3 1/2"	4"	6"	12"
H7067	16	4"	4 1/2"	6"	12"
<b>90° BENDS 304 STAINLESS STEEL (A269)</b>					
H6954	16	2 1/2"	4"	6"	6"
H6955	16	3"	6"	6"	6"
<b>120° BENDS MILD STEEL (1010)</b>					
H7070	16	3"	3 1/2"	6"	12"
H7069	18	3"	3 1/2"	6"	12"
H7071	16	3 1/2"	4"	6"	12"
H7072	16	4"	4 1/2"	6"	12"
<b>120° BENDS ALUMINIZED (A787)</b>					
H7089	16	3 1/2"	4"	6"	12"
H7092	16	4"	4 1/2"	6"	12"

PART NO.	GAUGE	TUBE DIAMETER	LENGTHS
<b>TUBING</b>			
<b>MILD STEEL (1010)</b>			
H7748	18	1 1/2"	5'
H7751	16	1 5/8"	5'
H7750	18	1 5/8"	5'
H7752	18	1 3/4"	5'
H7755	16	1 7/8"	5'
H7754	18	1 7/8"	5'
H7757	16	2"	5'
H7756	18	2"	5'
H7759	16	2 1/8"	5'
H7758	18	2 1/8"	5'
H7761	16	2 1/4"	5'
H7760	18	2 1/4"	5'
H7763	16	2 1/2"	5'
H7762	18	2 1/2"	5'
H7765	16	3"	5'
H7764	18	3"	5'
H7767	16	3 1/2"	5'
H7768	16	4"	5'
<b>ALUMINIZED (A787)</b>			
H7782	16	2 1/2"	5'
H7786	16	3 1/2"	5'
H7788	16	4"	5'
<b>304 STAINLESS STEEL (A269)</b>			
H7700	18	1 1/4"	5'
H7701	18	1 3/8"	5'
H7702	18	1 1/2"	5'
H7703	18	1 5/8"	5'
H7704	18	1 3/4"	5'
H7705	18	1 7/8"	5'
H7706	18	2"	5'
H7707	16	2"	5'
H7708	18	2 1/8"	5'
H7709	16	2 1/8"	5'
H7710	18	2 1/4"	5'
H7711	16	2 1/4"	5'
H7712	18	2 3/8"	5'
H7713	16	2 3/8"	5'
H7714	18	2 1/2"	5'
H7715	16	2 1/2"	5'
H7716	18	3"	5'
H7717	16	3"	5'
H7718	16	3 1/2"	5'





**PICTURE GALLERY**



**H4800-1**



**H4803**



**H4830**



**H4830-1**



**H4850-1**



**H4851-1**



**H8005**



**H8007**



**H8011**



**H8012-1**



**H8013-1**



**H8015**



**H8017-1**



**H8018-1**



**H8020-1**



**H8021-1**



**PICTURE GALLERY**



**H8022-1**



**H8023-1**



**H8024-1**



**H8025**



**H8025-1**



**H8026-1**



**H8031-1**



**H8032**



**H8033-1**



**H8035-1**



**H8036**



**H8036-1**



**H8038-1**



**H8039-1**



**H8040-1**



**H8043**



**PICTURE GALLERY**



**H8044-1**



**H8045-1**



**H8046-1**



**H8047-1**



**H8048-1**



**H8049-1**



**H8050-1**



**H8051-1**



**H8054-1**



**H8055-1**



**H8056-1**



**H8057-1**



**H8058-1**



**H8059-1**



**H8061-1**



**H8062-1**



## **PICTURE GALLERY**



**H8063-1**



**H8068-1**



**H8069-1**



**H8071-1**



**H8073**



**H8073-1**



**H8074-1**



**H8075**



**H8076-1**



**H8077-1**



**H8078-1**



**H8079-1**



**H8084-1**



**H8087-1**



**H8089-1**



**H8091**





**PICTURE GALLERY**



**H8093**



**H8096-1**



**H8100-1**



**H8101-1**



**H8206-1**



**H8207-1**



**H8208-1**



**H8209-1**



**H8210-1**



**H8301-1**



**H8302-1**



**H8401-1**



**H8402-1**



**H8403-1**



**H8405-1**



**H8406-1**



## **PICTURE GALLERY**



**H8407-1**



**H8408-1**



**H8409-1**



**H8410**



**H8411-1**



**H8412-1**



**H8413-1**



**H8414**



**H8420-1**



**H8422-1**



**H8423-1**



**H8425-1**



**H8426**



**H8426-1**



**H8429-1**



**H8431-1**



**PICTURE GALLERY**



**H8433-1**



**H8435-1**



**H8436-1**



**H8440**



**H8467-1**



**H8469-1**



**H8471-1**



**H8472-1**



**H8473-1**



**H8474-1**



**H8475-1**



**H8476-1**



**H8477-1**



**H8501-1**



**H8503-1**



**H8504**



## PART NUMBER INDEX

PART NO.	PAGE NO.	PART NO.	PAGE NO.	PART NO.	PAGE NO.	PART NO.	PAGE NO.	PART NO.	PAGE NO.
H1050.....	22	H3344.....	24	H6929.....	33	H7050.....	33	H7253.....	29
H1060.....	22	H3345.....	24	H6930.....	33	H7051.....	33	H7254.....	29
H1070.....	22	H3348.....	24	H6931.....	33	H7052.....	33	H7257.....	29
H1080.....	22	H3349.....	24	H6932.....	33	H7053.....	32	H7258.....	29
H1128.....	28	H3453.....	24	H6933.....	33	H7054.....	32	H7259.....	29
H1129.....	28	H3456.....	24	H6934.....	33	H7055.....	33	H7260.....	29
H1130.....	28	H3543.....	24	H6935.....	33	H7056.....	33	H7261.....	29
H1131.....	28	H3544.....	24	H6936.....	33	H7057.....	33	H7265.....	29
H1132.....	28	H3554.....	24	H6937.....	33	H7058.....	32	H7266.....	29
H1133.....	28	H3558.....	24	H6938.....	33	H7059.....	32	H7267.....	29
H1134.....	28	H3800.....	25	H6939.....	33	H7060.....	33	H7268.....	29
H1135.....	28	H3801.....	25	H6940.....	33	H7061.....	34	H7269.....	29
H1145.....	7	H3805.....	25	H6941.....	33	H7062.....	34	H7320.....	26
H1146.....	7	H3811.....	7	H6942.....	33	H7063.....	34	H7321.....	26
H1165.....	23	H3812.....	9, 22	H6950.....	34	H7064.....	33	H7323.....	26
H1170.....	23	H3813.....	27	H6951.....	34	H7065.....	33	H7324.....	26
H1175.....	23	H3814.....	27	H6952.....	34	H7066.....	33	H7327.....	26
H1180.....	23	H3815.....	27	H6954.....	34	H7067.....	34	H7328.....	26
H1185.....	23	H3816.....	9, 22	H6955.....	34	H7068.....	33	H7329.....	26
H1260.....	23	H3817.....	9, 22, 27	H6956.....	32	H7069.....	34	H7331.....	26
H1263.....	23	H3818.....	9, 22	H6957.....	32	H7070.....	34	h7402.....	22
H1264.....	23	H3819.....	9, 22	H6958.....	32	H7071.....	34	H7402.....	28
H1270.....	23	H3820.....	9, 22	H7000.....	33	H7072.....	34	H7432.....	22
H1273.....	23	H3821.....	9, 22	H7001.....	32	H7073.....	33	H7433.....	22
H1274.....	23	H3822.....	9, 22	H7002.....	32	H7074.....	33	H7434.....	22
H1280.....	23	H3824.....	9, 22	H7003.....	32	H7075.....	32	H7435.....	22
H1283.....	23	H3832.....	20	H7006.....	33	H7076.....	32	H7452.....	22
H1284.....	23	H3833.....	20	H7007.....	33	H7077.....	33	H7453.....	22
H1285.....	23	H3834.....	20	H7008.....	32	H7078.....	32	H7454.....	22
H1286.....	23	H3840.....	25	H7009.....	33	H7080.....	32	H7506.....	31
H1381.....	23	H3842.....	25	H7010.....	33	H7081.....	33	H7518.....	31
H1384.....	23	H3843.....	25	H7011.....	33	H7083.....	32	H7546.....	31
H1505.....	26	H3844.....	25	H7012.....	33	H7084.....	33	H7553.....	31
H1530.....	26	h3845.....	7	H7013.....	32	H7089.....	34	H7554.....	31
H1531.....	26	H3950.....	22	H7014.....	33	H7090.....	33	H7555.....	31
H1532.....	26	H3952.....	22	H7015.....	33	H7092.....	34	H7557.....	31
H1533.....	26	H3954.....	22	H7016.....	33	H7093.....	33	H7559.....	31
H1534.....	26	H4800.....	20, 35	H7017.....	33	H7172.....	28	H7572.....	31
H1535.....	26	H4803.....	20, 35	H7018.....	32	H7173.....	28	H7573.....	31
H1542.....	26	H4830.....	20, 35	H7019.....	32	H7174.....	28	H7574.....	31
H1543.....	26	H4850.....	20, 35	H7020.....	32	H7175.....	28	H7581.....	31
H1546.....	26	H4851.....	20, 35	H7021.....	32	H7176.....	28	H7582.....	31
H1570.....	26	H6900.....	32	H7022.....	32	H7177.....	28	H7583.....	31
H1571.....	26	H6901.....	32	H7023.....	33	H7179.....	28	H7584.....	31
H1572.....	26	H6902.....	32	H7024.....	33	H7180.....	28	H7585.....	31
H1593.....	26	H6903.....	32	H7025.....	33	H7181.....	28	H7586.....	31
H1607.....	26	H6904.....	32	H7026.....	33	H7229.....	27	H7587.....	31
H1620.....	26	H6905.....	32	H7027.....	33	H7230.....	29	H7588.....	31
H2950.....	26	H6906.....	32	H7028.....	32	H7231.....	27	H7589.....	31
H2963.....	26	H6907.....	32	H7029.....	32	H7232.....	27	H7590.....	31
H2964.....	26	H6908.....	32	H7030.....	33	H7233.....	27	H7591.....	31
H2965.....	26	H6909.....	32	H7031.....	33	H7235.....	27	H7592.....	31
H2970.....	25	H6910.....	32	H7032.....	32	H7236.....	27	H7593.....	31
H2971.....	25	H6911.....	32	H7033.....	33	H7237.....	27	H7594.....	31
H3010.....	24	H6912.....	32	H7034.....	33	H7238.....	27	H7595.....	31
H3011.....	24	H6913.....	32	H7036.....	32	H7239.....	27	H7596.....	31
H3012.....	24	H6914.....	32	H7037.....	33	H7240.....	28	H7597.....	31
H3013.....	24	H6915.....	32	H7038.....	33	H7241.....	28	H7602.....	28
H3014.....	24	H6916.....	32	H7039.....	33	H7242.....	27	H7603.....	28
H3015.....	24	H6917.....	32	H7040.....	33	H7243.....	27	H7604.....	28
H3016.....	24	H6918.....	32	H7041.....	32	H7244.....	27	H7606.....	27
H3017.....	24	H6919.....	32	H7042.....	32	H7245.....	27	H7607.....	27
H3018.....	24	H6920.....	32	H7043.....	32	H7246.....	27	H7608.....	27
H3110.....	25	H6921.....	32	H7044.....	32	H7247.....	27	H7609.....	27
H3120.....	25	H6924.....	32	H7045.....	33	H7248.....	27	H7613.....	28
H3121.....	25	H6925.....	33	H7046.....	33	H7249.....	27	H7621.....	27
H3132.....	25	H6926.....	33	H7047.....	33	H7250.....	27	H7624.....	27
H3133.....	25	H6927.....	33	H7048.....	32	H7251.....	27	H7628.....	27
H3200.....	24	H6928.....	33	H7049.....	32	H7252.....	27	H7631.....	27





## FOOTNOTES

- 1 Does not fit angle plug heads
- 3 Fits with stock or 605 steering boxes, aftermarket side engine mounts and rear trans cross member
- 4 Fenderwell exit
- 5 Mid Length design for maximum ground clearance
- 8 Kits consist of 8 mandrel bent header tubes, flange kit and formed collectors
- 10 Outside frame exit
- 13 May require smaller front tires to avoid contact.
- 14 37-57 Chevy applications require alteration of emergency brake rod
- 15 Can be used with most oil filter system or transmission and starter combination
- 16 Tucks very close to engine
- 17 Fits most angle plug heads
- 18 Header installation requires the use of the 1965-66 Non Hi-Po V8 clutch equalizer bar
- 19 Check motor mount position before ordering
- 20 Chrome headers are polished before and after assembly for show quality appearance
- 23 Will not fit if engine is located more than 3/4" forward for HEI firewall clearance. Fits with TCI engine mount kit PN 725-7005-80 and with the equivalent Danchuk mounts.
- 26 67-70 models require additional driver's side header clearance around the steering box
- 32 Fits only when a 62-67 type intake manifold is used
- 36 Fits D-Port cylinder heads including ZZ4 crate engines
- 37 Fits standard deck big blocks only
- 41 Kit includes header flanges, collector flanges, block-off plates, four exhaust hookup flanges, pre-bent header tubes and two collector cones
- 43 Exits toward front tire
- 44 Can be run upside down to gain clearance but will require relocating water temperature sending unit
- 45 Fits with side or front motor mounts
- 46 Fits with stock, Mustang, Vega or Saginaw steering
- 47 Fits with stock, Mustang and Vega steering
- 49 Fits 71-74 passenger cars and wagons with auto trans column shift only
- 52 Will not fit with Saginaw Close Ratio 825 Steering Box
- 53 Not recommended for generation six 502cid engines with aluminum heads
- 54 Fits with manual and auto trans floor shifts only
- 55 Fits GT40 "P" head
- 56 Stepped pipe design increases low end torque without sacrificing higher RPM performance
- 57 Slip on style 90 and 45 degree collectors are adjustable for tuning and footbox location
- 58 Header uses dual collector design for increased torque
- 59 Fits the flathead six engine but does not provide for heat exchange to the stock cast intake manifold
- 60 Will not fit with 168 tooth flywheels or kickout aftermarket starters
- 61 Does not fit 67-69 Camaro with A/C
- 62 Must use 66 1/2 or later frame brackets (approx. 1" higher than 65 and early 66 style)
- 63 Does not fit manual transmissions using factory mechanical clutch linkage
- 64 Fits with manual transmissions using 85-95 bellhousings with cable clutch kits
- 65 Fits with solid side and rear mounts
- 66 Does not clear stock manual clutch linkage ball located behind the #7 cylinder
- 67 Fits with most engine swap kits
- 68 Fits with Turbo 350 automatic transmissions with floor shifter only
- 69 Big block frame stands and motor mounts must be used to insure proper engine location and header fit.
- 70 Fits production chassis exiting under the car
- 71 Does not clear 2.0L stock motor mount
- 72 Goes through firewall if used on a production Pinto/Mustang II chassis.
- 73 See pages 13 for specific fit applications
- 74 Fits Brodix spread port cylinder heads
- 75 Fuel injected engines only
- 76 Fits with either the Danchuk 3/4" forward or their stock location side mounts, rear transmission mount or equivalent and stock or 605 steering boxes. Stock mid mount and ears on the frame must be removed
- 78 Must replace the stock oil pan with a Canton 16-100 two piece or 16-100T one piece style rear main seal
- 83 Fits with manual transmissions using 10" or 10.5" clutch only. 1968-up bellhousings require driver's side header clearance
- 84 Non-HiPo cars with manual transmission may need header clearance for clutch linkage
- 85 Equipped with 02 Sensor Bungs
- 87 Requires a Doug's LS1 /LS6 motor mount adapter plate kit P/N SK101 or equivalent.
- 88 Fits two barrel heads
- 89 Fits four barrel heads (Boss 351)
- 90 Does not fit with C-6 transmission
- 91 Y Pipe available part number H1100
- 92 Requires removal or modification of locking steering columns if equipped
- 94 Non catalytic converter equipped.
- 95 Reducers available with 02 sensor fitting see catalog page 27
- 96 Installation requires left side A/C bracket part number H7608.1979 and later vehicles with short compressors can use the stock bracket.
- 97 Installation requires power steering bracket PN H7609
- 98 Fits with C-6 transmission.
- 99 Does not fit 1971-73 Mustang/Cougar with manual transmission.
- 100 Will not fit models with air injection cylinder heads
- 102 Replica of early Shelby Tri-Y header.
- 103 Jaguar exhaust systems available separately.
- 104 Some factory heads do not have end bolt holes and should be drilled and tapped to assure proper sealing.
- 105 Original bellhousing frame mounts must be removed.
- 106 Fits factory installed Chevrolet 267, 305, 350 engines.
- 107 LS1/LS6 engines require the use of a LS1 oil pan for proper header fit.
- 108 Will fit with 605 power steering box
- 110 Fits 1953 models with transplanted Y block engines when 1954-64 Y block motor mounts are used.
- 111 Long tube headers for closed course competition only
- 113 Replacement shorty style header which bolts directly to '86 and later factory headpipe
- 116 Replacement shorty style header which bolts directly to '94 and later factory headpipe
- 121 50-State Legal C.A.R.B. E.O. #D-57-29, D-57-31
- 126 Tri-Y design
- 143 Comes with EGR provision
- 155 Shorty header that bolts directly to factory headpipes
- 164 Dog leg exhaust port
- 171 Passenger side header has rear exit
- 172 Over frame design with outside exit and provision for exhaust system hookup (lakester style)
- 180 Requires Doug's LS1 adapter plate kit P/N SK100, American Tour Specialties or equivalent
- 188 Fits "Pro Four" tube chassis style
- 192 Header is designed to fit cars using original V-8 pitman arm part number 3719487 not 6 cylinder pitman arm number 3709877. Aftermarket pitman arms must be same configuration as OE for proper header fit.
- 196 Lakewood bell housings require clearancing for header tubes
- 197 Use recommended C5ZZ16A052E "export brace" if shock mount center to center dimension is less than 33 3/4"
- 202 Will fit Detroit Speed & Engineering front subframes with rack and pinion steering
- 203 Will not fit models equipped with air injection pump without modification
- 211 Designed to fit with Maval/Unisteer rack and pinion steering systems
- 212 Will not fit manual transmission cars with factory Z bar clutch linkage
- 214 Must use non-shell type motor mounts
- 223 Fits with Modern Driveline T5 cable clutches and AOD transmissions
- 224 Fits with Danchuk Mount kit #12184 or equivalent
- 228 Will not fit GT40 "P" head
- 229 Will fit T-5 transmission with hydraulic clutch or stock Z Bar
- 231 Modification to stock headpipe required

## PerTronix Ignition Brands

### Flame-Thrower®

Ignition Coils - Spark Plug Wires  
HEI and Billet Distributors  
Ignition Modules

### Second Strike® Digital Rev Limiter

Multi-Spark CD Box

Digital Rev Control Box

### Ignitor® III

Ignition box performance... without the "box"!

### Ignitor® II

Micro-controlled Electronic Ignition  
for point type distributors

### IGNITOR®

Solid-State Electronic Ignition  
for point type distributors

## PerTronix Exhaust Brands

### The original DOUG'S HEADERS

Muscle Car and Street Rod Headers

### JBA performance exhaust®

Late Model Truck, SUV and Passenger Car  
Headers & Exhaust Systems

### PATRIOT®

Street Rod and Muscle Car Headers  
Side Exhaust - Do-It-Yourself Products



## Limited One Year Warranty

All Patriot headers and exhaust products are guaranteed, to the original purchaser, to be free of defects in materials and workmanship for one year. This warranty covers the replacement or repair of the product only and does not cover the cost of removal and installation, customer applied aftermarket coatings or any discoloration or corrosion of finished surfaces.

Damage or product failure resulting from collision, improper installation, off-road use, road hazards, the use of exhaust insulating wrap or like products or rust occurring after installation, is not covered by the warranty. The warranty extends only to the original purchaser.

Should a part become defective it should be returned to the original selling retailer and must be accompanied with the sales receipt. If there is no retailer in your area, call the factory for a return authorization and return your part prepaid to the factory for inspection. PerTronix reserves the rights to replace or repair the alleged defective part and return the part freight collect.

**PATRIOT**<sup>®</sup>  
Exhaust Products

***FIT***

***APPEARANCE***

***PERFORMANCE***

***YOU CAN***

***COUNT ON!***

