



PAUL SELLERS' WORKBENCH MEASUREMENTS AND CUTTING LIST

Paul Sellers

NOTE

When putting together the cutting list for my workbench, I worked in imperial, the system with which I am most comfortable. I was not happy, however, to then provide direct conversions to metric because to be accurate and ensure an exact fit this would involve providing measurements in fractions of millimetres. When I do work in metric I find it more comfortable to work with rounded numbers, therefore I have created two slightly different sets of measurements. This means that in places the imperial measurement given is not a direct conversion of the metric measurement given. Therefore, I suggest you choose one or other of the systems and follow it throughout.

WOOD

QTY	DESCRIPTION	SIZE (IMPERIAL) (THICK X WIDE X LONG)	SIZE (METRIC) (THICK X WIDE X LONG)
4	Leg	2 ¾" x 3 ¾" x 34 ¾"	70 x 95 x 875mm
1	Benchtop	2 ¾" x 12" x 66"	65 x 300 x 1680mm
2	Apron	1 ⅝" x 11 ½" x 66"	40 x 290 x 1680mm
1	Wellboard	1" x 12 ½" x 66"	25 x 320 x 1680mm
4	Rail	1 ½" x 6" x 26"	40 x 150 x 654mm
2	Bearer	1 ¼" x 3 ¾" x 25"	30 x 95 x 630mm
4	Wedge	⅝" x 1 ½" x 9"	16 x 40 x 228mm
4	Wedge retainer	⅝" x 1 ½" x 4"	16 x 40 x 100mm

HARDWARE

QTY	DESCRIPTION	SIZE (IMPERIAL)	SIZE (METRIC)
1	Vise	9"	225mm
4	Dome head bolts (including nuts and washers) for bolting legs to aprons	⅜" x 5"	10 x 130mm
2	Lag screws (with washers) for underside of vise	½" x 2 ½"	12 x 65mm
2	Lag screws for face of the vise	5/16" x 2 ¾"	8 x 70mm
2	Lag screws for back apron	5/16" x 2 ¾"	8 x 70mm
	Various screws of various sizes	1 ¼" x 3 ¾" x 25"	

TOOL LIST

- Square
- Knife
- Pencil
- Tape measure
- Combination gauge (or marking gauge plus mortise gauge)
- Tenon saw
- Handsaw
- Chisel set $\frac{1}{2}$ " , $\frac{3}{4}$ " and 1" (12mm, 18mm and 25mm)
- Chisel hammer or mallet
- Smoothing plane
- Brace and bits (or screw gun and bits to suit)
- Router plane**
- Plough plane**
- Rabbet/filletster plane**
- Hammer (steel)*
- 10" steel rule*
- Jack plane*
- 10" rasp*
- 10" flat file*
- Winding sticks

*Optional

**Optional but highly recommended

EQUIPMENT LIST

- A workbench or improvised support of some kind such as:
 - Two saw trestles or...
 - a portable, folding workbench or...
 - a picnic table.
- Seven or so 36" (91cm) sash clamps (for frame clamping and clamping the laminated top)
- Some shorter sash clamps, bar clamps or G-clamps

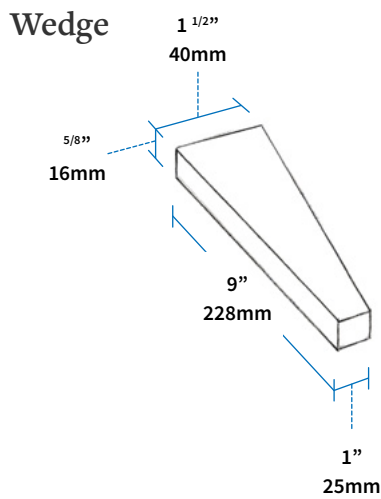
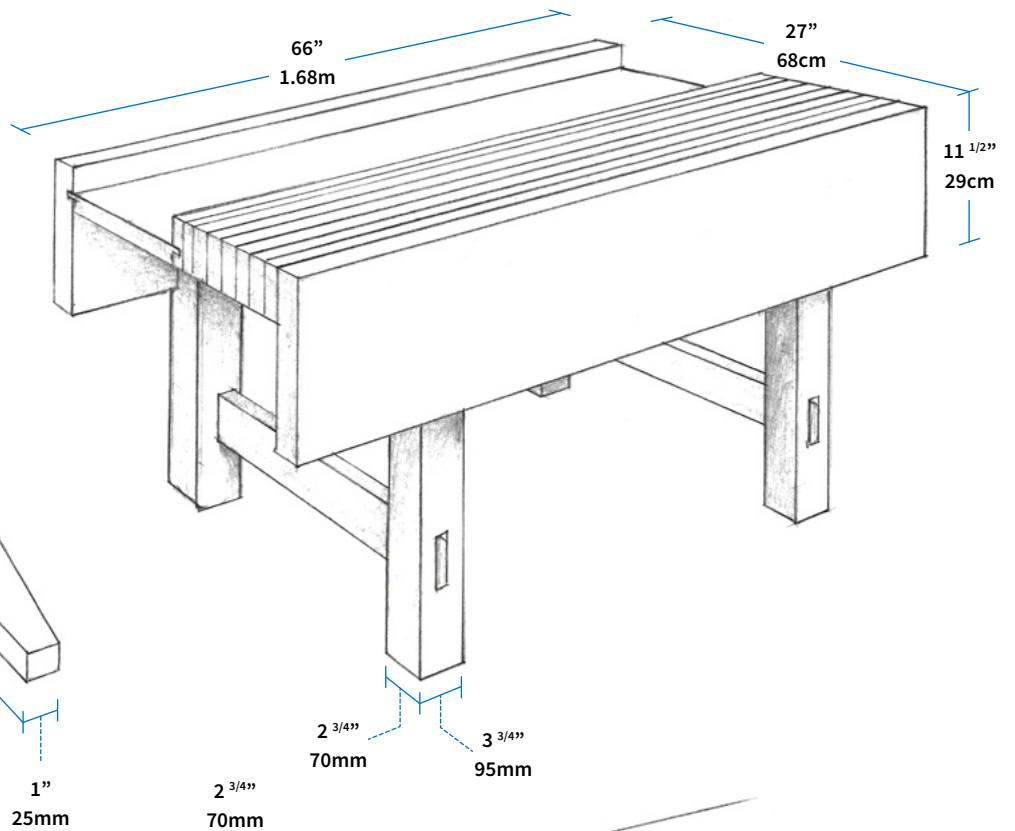
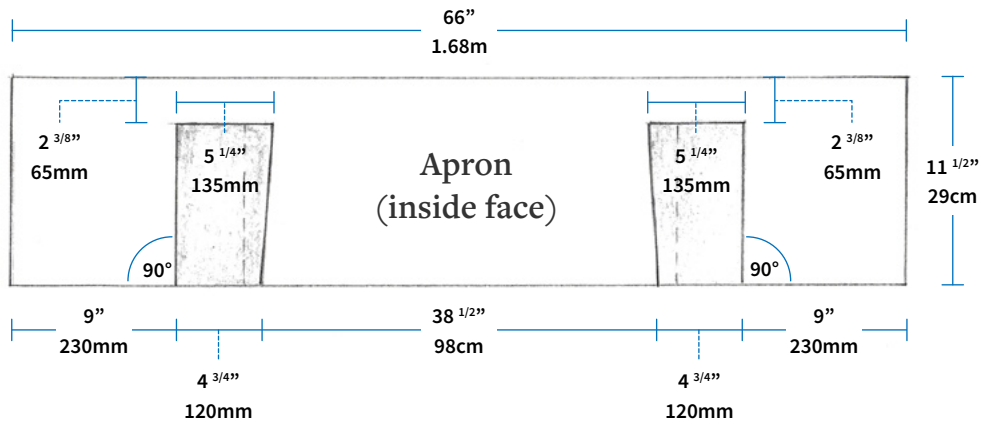

Rail joinery

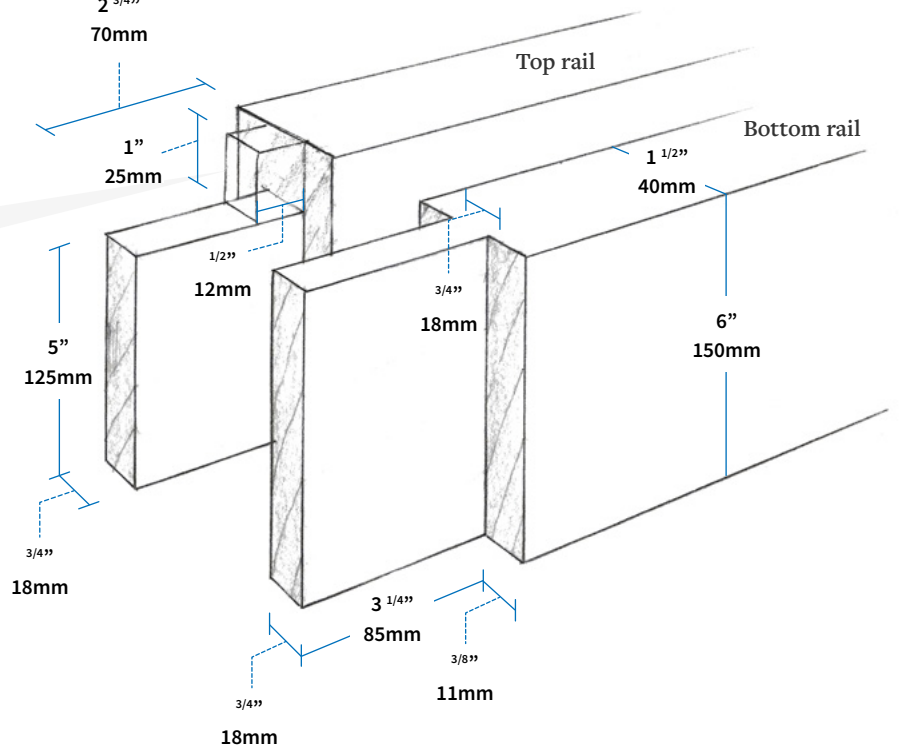

Note:
 Haunches on the top rail tenons are optional.

Note:
 The bottom rail is longer than the top rail to allow for protruding tenons.

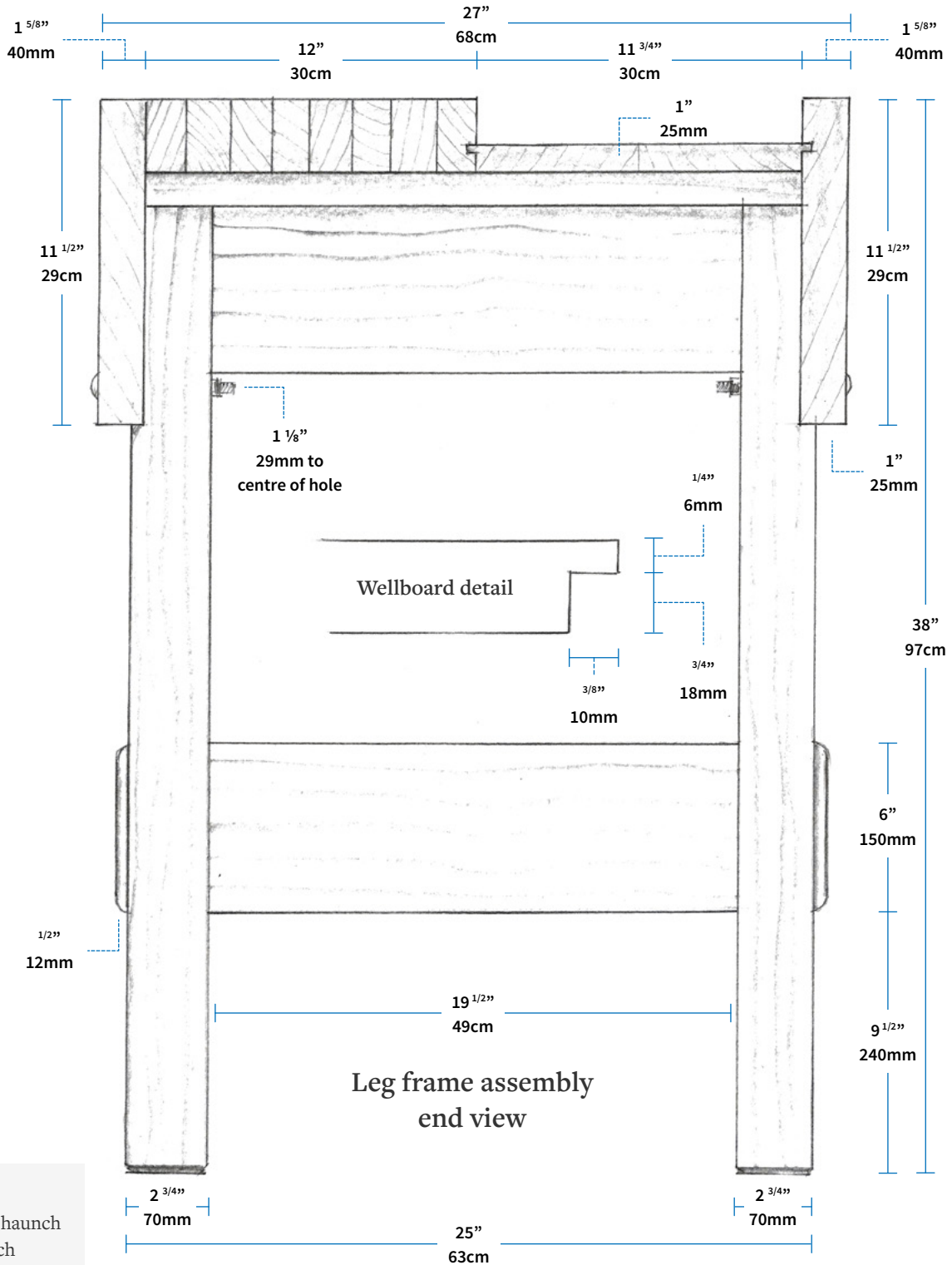

Note:
This is the haunch recess which you only need if you are using haunched tenons.

Leg mortise hole layout (inside face)

