

SUBMITTAL DATA: PKA-A12HA7 & PUY-A12NKA7

12,000 BTU/H WALL-MOUNTED AIR-CONDITIONING SYSTEM

Job Name: _____ The review by JRP Engineering is for the sole purpose of ascertaining conformance with the general design concept. This review shall not mean the detail design inherent in the shop drawings are approved, responsibility of which shall remain with the Contractor submitting same and review shall not relieve the Contractor of this responsibility for errors or omissions in the shop drawings or his responsibility for meeting all requirements of the Contract Documents. The Contractor is responsible for dimensions to be confirmed and correlated at the job site, for information that pertains solely to fabrication processes or to techniques of construction and installation and for co-ordination of the work of all sub-trades.
 Purchaser: _____
 Submitted To: _____
 Submitted By: _____
 System Designation: _____



Indoor Unit: PKA-A12HA7



Outdoor Unit: PUY-A12NKA7 (BS)

UNIT OPTION:

Standard Model.....PUY-A12NKA7
 Seacoast (BS) Model.....PUY-A12NKA7-BS

ACCESSORIES:

Controls

- Wireless Controller (MHK1)
- Advanced Wired Controller (PAR-32MAA)
- Simple Wired Controller (PAC-YT53CRA)
- Wireless Remote Controller (PAR-FL32MA)
- M-NET Adapter (PAC-SF83MA-E)

Project Name	TOMLINSON
APPROVED	<input type="checkbox"/> REJECTED
REVISE	<input type="checkbox"/> REVIEWED
BY	CARL MUIR
DATE	3/28/2017
SUBMITTAL#	SPEC 1 TON AC

Outdoor Unit

- Front Wind Gaurd (PFR-12-18)
- Rear Wind Gaurd (PRE-12-18)
- Side Wind Guard (PSD-12-18)

CONDENSER WALL MOUNT

SPECIFICATIONS:

Rated Conditions (Capacity / Input)*		
Cooling	Btu/h / W	12,000 / 1,000

* Rating Conditions per AHRI Standard:
 Cooling | Indoor: 80°F (27°C) DB / 67°F (19°C) WB
 Cooling | Outdoor: 95°F (35°C) DB / 75°F (24°C) WB

Capacity Range		
Cooling	Btu/h	5,800 - 12,000

Operating Range		
Cooling		-20F** (-28.9°C) to 115°F (46°C) DB
Ultra-Low Ambient Cooling		-40F** (-40.0°C) to 115°F (46°C) DB

** The minimum temperature will be 23°F (-5°C) DB if optional wind baffle accessory is not installed

AHRI Efficiency Rating	
EER	12.0
SEER	20.8

Specifications are subject to change without notice.

Electrical Power Requirements	200 / 230V, 1-Phase, 60 Hz
Minimum Circuit Ampacity (MCA)	
Indoor / Outdoor (RBS)	A 1 / 11 (15A - Recommended Breaker Size)
Indoor Unit	
Fan Motor (ECM)	F.L.A. 0.33
Fan Motor Output	W 30
SHF / Moisture Removal	0.81 / 2.0 pt./h
Field Drainpipe Size O.D.	In.(mm) 5/8 (16)

Compressor	DATE: March 31st, 2017	iry
Fan Motor (ECM)	F.L.A.	0.5
Fan Motor Power	W	46

Airflow Rate (Low-Mid-Hi)			
Indoor (Cooling)	DRY	CFM	320-370-425
	WET		290-335-380
Outdoor	DRY		1,590

Sound Pressure Level			
Indoor (Low-Mid-Hi)	dB(A)	36-40-43	
		Outdoor	Cooling

External Dimensions			
Indoor (H x W x D)	In.(mm)	11-5/8 x 35-3/8 x 9-13/16 (295 x 898 x 249)	
		24-13/16 x 31-13/16 + 7/16 x 11-3/16 (630 x 809 + 62 x 300)	
Outdoor (H x W x D)			

Net Weight		
Indoor	Lbs.(kg)	29 (13)
Outdoor		92 (41)

External Finish	
Indoor	White Munsell No. 1.0Y 9.2/0.2
Outdoor	Ivory Munsell No. 3Y 7.8 / 1.1

Refrigerant	R410A ; 4lbs.,7oz. (2.0kg)
-------------	----------------------------

Refrigerant Piping (Flared)			
Liquid (High Pressure)	In.(mm)	1/4 (6.35)	
Gas (Low Pressure)		1/2 (12.7)	
Maximum Total Refrigerant Pipe Length	Ft. (m)	165 (50)	
Maximum Vertical Separation	Ft. (m)	100 (30)	

DIMENSIONS: PKA-A12HA7

Unit: in. (mm)

- REVIEWED
- REVIEWED AND MODIFIED
- REVISE AND RESUBMIT
- NOT REVIEWED

The review by JRP Engineering is for the sole purpose of ascertaining conformance with the general design concept. This review shall not mean the detail design inherent in the shop drawings are approved, responsibility of which shall remain with the Contractor submitting same and review shall not relieve the Contractor of this responsibility for errors or omissions in the shop drawings or his responsibility for meeting all requirements of the Contract Documents. The Contractor is responsible for dimensions to be confirmed and correlated at the job site, for information that pertains solely to fabrication processes or to techniques of construction and installation and for re-ordination of the work of all sub-trades.

JRP Engineering

M. Karakolis

DATE: March 31st, 2017

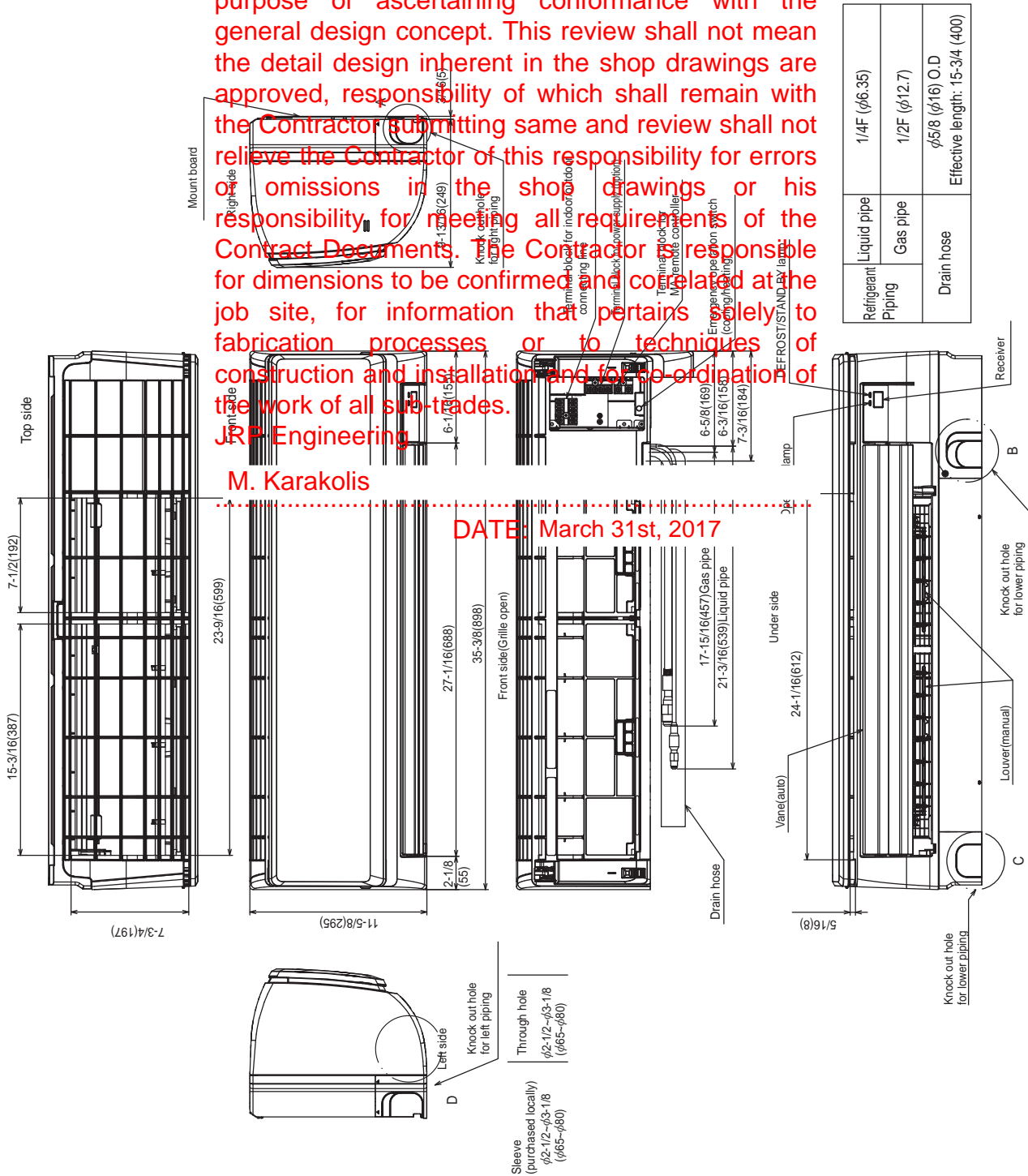

Specifications are subject to change without notice.

DIMENSIONS: PUY-A12NKA7

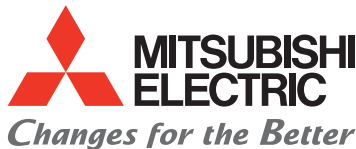
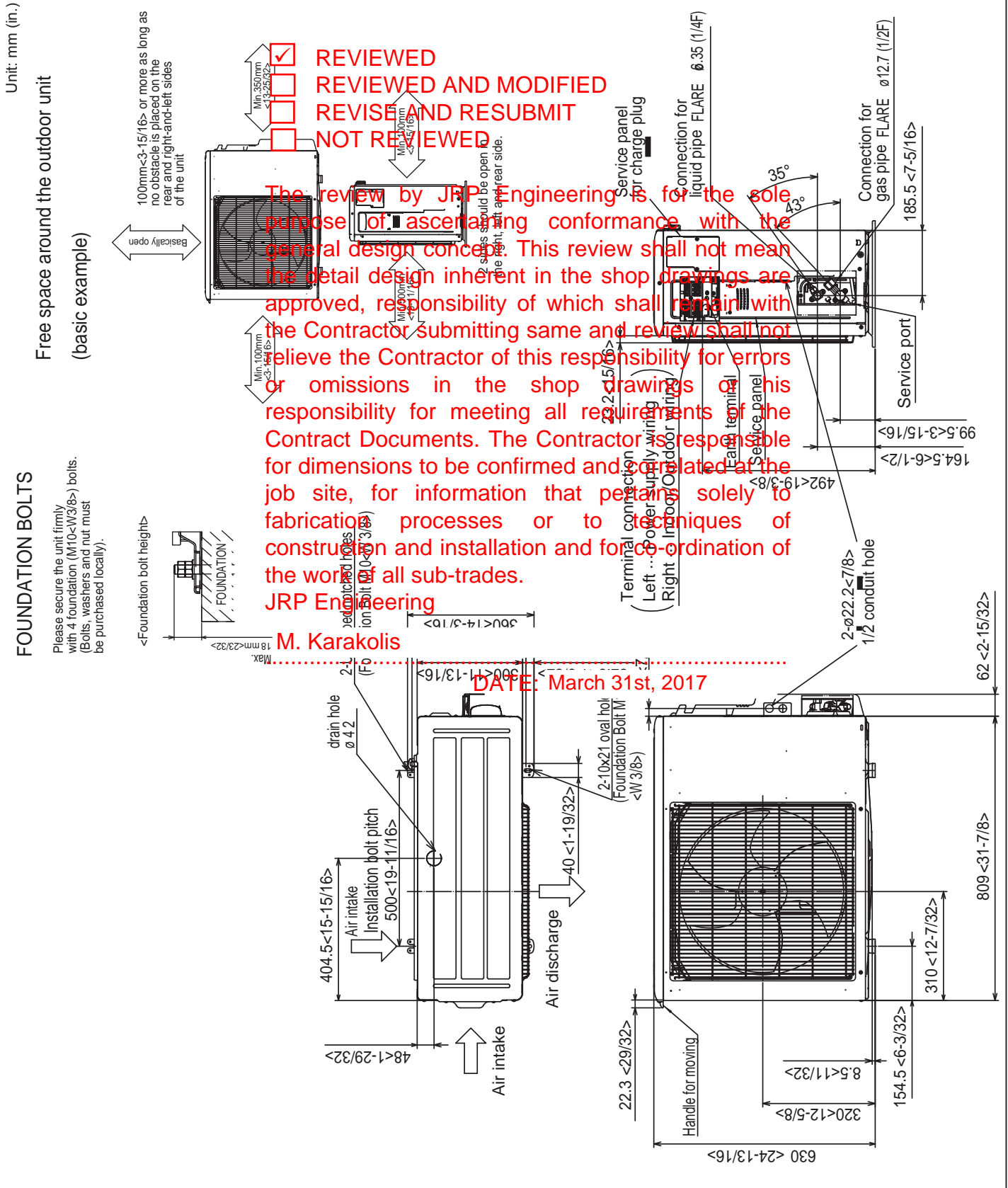

for a greener tomorrow



Job Name:

Schedule Reference:

Date:

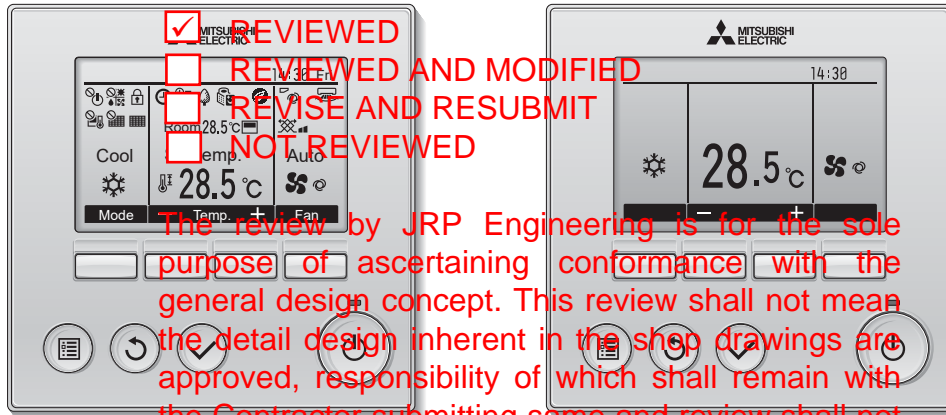

The review by JRP Engineering is for the sole purpose of ascertaining conformance with the general design concept. This review shall not mean the detail design inherent in the shop drawings are approved, responsibility of which shall remain with the Contractor submitting same and review shall not relieve the Contractor of this responsibility for errors or omissions in the shop drawings or his responsibility for meeting all requirements of the Contract Documents. The Contractor is responsible for dimensions to be confirmed and operated at the job site for information that pertains solely to fabrication processes and techniques of construction and installation and for co-ordination of the work of all sub-trades.

JRP Engineering
M. Karakolis

DATE: March 31st, 2017

CAPABILITIES:

- Basic Operations
 - On/Off
 - Operation Mode: Cool, Dry, Fan, Heat, Auto (Dual or Single set point)
 - Set Temperature
 - Fan Speed
- Vane setting: Auto, Step 1-5, Swing
- Louver: Off, Swing On
- Vent. (Lossnay): Off, Low, High
 - Manual vane angle: No Setting, Step 1-5, Draft reduction, All outlet
 - Draft reduction mode keeps the vane angle most horizontal that the angle of Step 1
- Restriction
 - Set Temperature range limit
 - Operation lock: On/Off, Mode, Set Temp, Vane
- High power
 - Operate at higher-than-normal capacity to bring room to set temperature quickly for up to 30 minutes
- No Occupancy Auto-OFF
 - 3D i-See sensor required
- On/Off timer
 - Set On Time in 5-minute increments
 - Set Off Time in 5-minute increments
 - Repeat daily
 - Home screen display icon
- Auto-Off timer
 - Automatically turns unit off after preset time
 - Time range of 30 to 240 minutes in 10-minute increments
 - Home screen display icon
- Weekly timer
 - Set each day Monday through Sunday
 - 1 to 4 time periods per day in 5-minute increments
 - Set Mode: On/Off/Auto (Dual set point)
 - On/Off/Auto
 - Set Temperature

- Outdoor temperature mode
 - Schedulable: Mon, Tue, Wed, Thu, Fri, Sat, Sun
 - Start/Stop times in 5-minute increments
 - Silent Levels: Normal, Middle, Quiet
 - Energy saving features.
 - Automatic return to preset temperature set point if set point is changed from the remote controller after a preset time range.
 - Filterless operation (Cool, Dry, Fan)
 - Heat preset temp: Heat, Auto-Heat
 - Range of 30 to 240 minutes in 10-minute increments
 - Energy-saving Operation Schedule
 - Operation Schedule
 - Four daily patterns with time periods in 5-minute increments and energy-saving rate 0% to 99%
 - 7 day programming
 - Night setback
 - Starts Heat/Cool operation when room temperature exceeds preset temperature range.
 - Adjustable time range in 5-minute increments
- Full shows all icons and values
- Basic Backlit
- Adjustable Contrast Level
- Language: English, French, Spanish, Italian, Portuguese, Greek, Turkish, Swedish
- CITY-MULTI® Function setting
- Filter maintenance notification
- Error code notification

*(All Capabilities are dependent on the model connected)

SPECIFICATIONS:

Product size (W x H x D)	In. (mm)	4 3/4 x 4 3/4 x 3/4 (120 x 120 x 19)
Net weight	Lbs. (kg)	9/16 (0.25)
Rated power supply voltage		12 VDC (supplied from indoor units)
Power consumption	W	0.3
Usage environment		Temperature: 0 ~ 40° C (32 ~ 104° F) Humidity: 30 ~ 90%RH (with no condensation)
Material	Panel	PMMA
	Main body	PC + ABS
Sound Pressure Level	dB(A)	>70 [A-weighted sound pressure level]

DIMENSIONS:

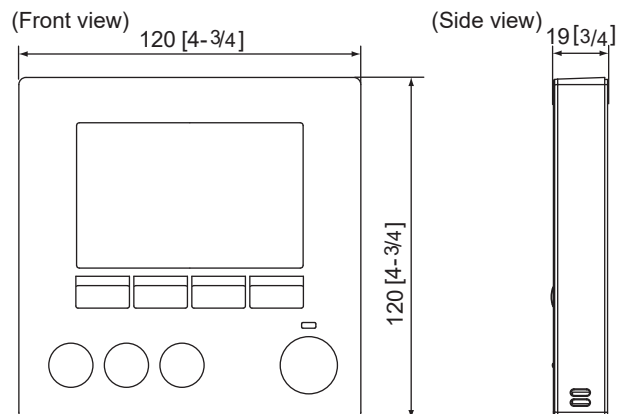

Notes:

Specifications are subject to change without notice.

Changes for the Better

TECHNOLOGY The review by JRP Engineering is for the sole

Outdoor unit model		A36	AA2
Outdoor unit power supply	~N (single), 60Hz, 208/230 V	~N (single), 60Hz, 208/230 V	~N (single), 60Hz, 208/230 V
Outdoor unit input capacity (Main switch (Breaker) **1)	30 A	30 A	30 A
Outdoor unit power supply	2 x Min. AWG 12	2 x Min. AWG 10	2 x Min. AWG 10
Outdoor unit-Outdoor unit	3 x AWG 14 (polar)	3 x AWG 14 (polar)	3 x AWG 14 (polar)
Indoor unit-Outdoor unit ground	1 x Min. AWG 14 (polar)	1 x Min. AWG 14 (polar)	1 x Min. AWG 14 (polar)
Remote controller-Indoor unit	2 x AWG 22 (Non-polar)	2 x AWG 22 (Non-polar)	2 x AWG 22 (Non-polar)

Please contact us for information regarding wiring responsibility for meeting all requirements of the options for connecting to BAS, Fire-shutdown, and other devices.

**STANDARD
1-PH DISCONNECT**

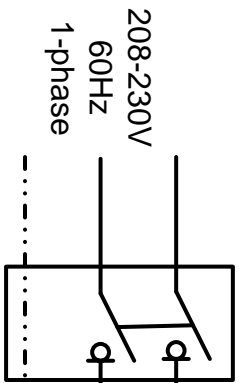

purpose of ascertaining conformance with the
design (electrical) shall not be the
detail design inherent in the shop drawings are
approved, responsibility of which shall remain with
Contractor submitting same and review shall not
Contractor (details responsibility for errors
shall be the shop drawings) 2 x AWG 22 (Non-polar)

responsibility for meeting all requirements of the
- Be sure to ground unit correctly
- Maximum separation is 248 feet, A24-42 (262 feet) between indoor/outdoor.
- Wiring shall be in accordance with applicable local and national codes. Use copper supply
wires only. Use wires rated 600V or more for the power supply and interconnecting cables.
construction and installation and for co-ordination of
the work of all sub-trades.

JRP Engineering [3-Pole INDOOR DISCONNECT]
M. Karakolis
DATE: March 31st, 2017

CONDENSATE PUMP WIRING:
If you are going to power a 208-230V condensate pump from the indoor unit, connect it to the S1-S2 terminals only.

DO NOT connect any external devices to the S3 communication line.

Use Breaker size as listed for Outdoor Unit above. Note *1

Correct polarity must be maintained for S1,S2,S3 wiring.

**OUTDOOR UNIT
TERMINALS**

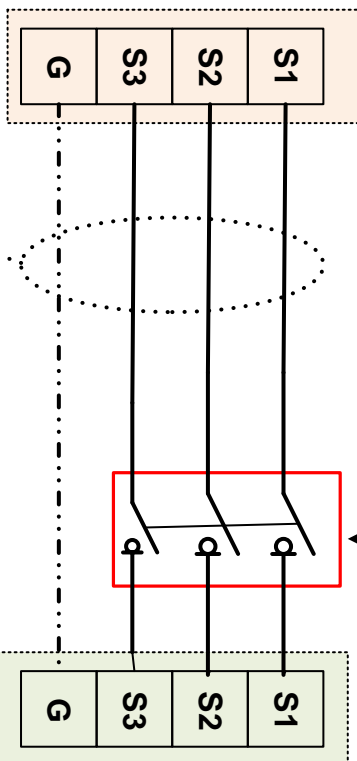

**INDOOR UNIT
TERMINALS**

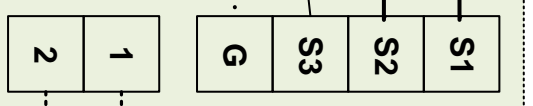

2-WIRE LVT (NON-POLAR)
Terminals 1-2 = 12 VDC
(See Note *4)



PAR-32MA
WIRED
REMOTE

Cable containing; 3 insulated conductors and a bare ground wire. (See Note *1,2)
S1-S2 = 208-230 VAC, S2-S3 = 24 VDC

Technical Specifications Manual Controller Switches

Pass & Seymour



30A, 600VAC, 1ø & 3ø

- REVIEWED
- REVIEWED AND MODIFIED
- REVISE AND RESUBMIT
- NOT REVIEWED

Typical Specifications	
Manufacturer's Identification: Pass & Seymour, Legrand 7802	
Description: Manual Controller, Double Pole, Single Phase	
Rating: 30A, 600VAC max.	
3rd Party Compliance: UL Listed, File Number E3199, Standard UL 508, Industrial Control Equipment, CSA Certified, File Number LR17949, Standard CSA-C22.23, No. 14, Industrial Control Equipment. Conforms to NEMA WDJ and WD-6.	

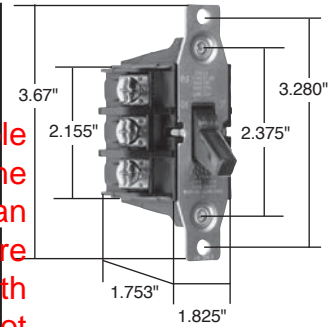

7802
7803



7812P
7813P

Catalog Number	Rating	Description
<input type="checkbox"/> 7802	General Use 30 600Max.	Double Pole, Single Phase AC Manual Motor Starting Switch (No overload protection)
<input type="checkbox"/> 7802MD	Same as 7802	7802, See Footnote 1
<input type="checkbox"/> 7812P	Same as 7802	7802 in a NEMA 1 Enclosure
<input type="checkbox"/> 7812PMD	Same as 7802	7802 in a NEMA 1 Enclosure
<input type="checkbox"/> 7812EX	Same as 7802	7802 in a NEMA 7 & 9 Enclosure for Hazardous Locations Class I - Groups C, D; Class II - Groups E, F, G
<input type="checkbox"/> 7832	Same as 7802	7802 in a NEMA 3R Enclosure
<input type="checkbox"/> 7832MD	Same as 7802	7832, See Footnote 1
<input type="checkbox"/> 7803	General Use 30 600Max.	Three Phase, Three Pole AC Manual Motor Starting Switch (No overload protection)
<input type="checkbox"/> 7803MD	Same as 7803	7803, See Footnote 1
<input type="checkbox"/> 7813P	Same as 7803	7803 in a NEMA 1 Enclosure
<input type="checkbox"/> 7813EX	Same as 7803	7803 in a NEMA 7 & 9 Enclosure for Hazardous Locations Class II - Groups E, F, G
<input type="checkbox"/> 7833	Same as 7803	7803 in a NEMA 3R Enclosure
<input type="checkbox"/> 7833MD	Same as 7803	7803, See Footnote 1

The review by JRP Engineering is for the sole purpose of ascertaining conformance with the general design concept. This review shall not mean the detail design information in the shop drawings are approved, responsibility of which shall remain with the Contractor submitting same and review shall not relieve the Contractor of this responsibility for errors or omissions in the shop drawings or his responsibility for meeting all requirements of the Contract Documents. The Contractor is responsible for dimensions to be confirmed and correlated at the job site, for information that pertains solely to fabrication processes or to techniques of construction and installation and for co-ordination of the work of all sub-trades.

JRP Engineering
M. Karakolis

DATE: March 31st, 2017

All Industrial Control Equipment is suitable for use in a circuit capable of deliverable not more than 5,000 rms amperes at 600VAC maximum or equivalent.

Footnote 1. Suitable as Motor Disconnect - 10KA @ 600VAC, 30A max. Class J Fuse

Performance			
Electrical			
Dielectric Withstand Voltage	2000V Minimum		
Maximum Working Voltage	600VAC		
Overload	50 cycles, 132 Amps/600VAC .5 PF		
Temperature Rise	50°C maximum		
Maximum Continuous Current	30A		
Endurance	1000 Cycles, 44Amp/600VAC 0.5 PF 5000 Cycles, 30Amp/600VAC 0.75 PF		
Mechanical			
Terminal Accommodations	#14 AWG - #10 AWG copper or copper-clad wire		
Environmental			
Flammability	UL94 V2		
Operating Temperature	Maximum continuous +75°C, minimum -40°C		
Materials			
Back Body	Nylon	Terminal Screws	Brass
Front Body	Nylon	Leaf Springs	Stainless Steel
Carrier	Nylon	Coil Springs	Zinc-Plated Steel
Toggle	Nylon	Strap	Zinc-Plated Steel
Contact Arm	Brass	Rivets	Brass
Terminals	Brass	Contacts	Silver Cadmium Oxide

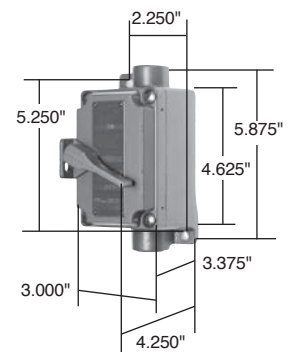

7812EX
7813EX

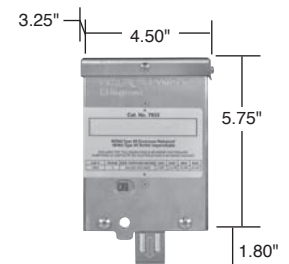

7832
7833

Project
Location/Type

Wind Guard Accessories

Designed for P-Series PUY/Z-A12_18NKA7 Model Units



Job Name:

Schedule Reference:

Date:

GENERAL FEATURES:

- Protects outdoor coil from wind for systems doing year round cooling and low ambient cooling operations only.
- 20-gauge satin coat steel (Galvanized), powder coated beige matching unit.

NOTES:

- Outdoor unit must be mounted at least 18" off the ground or 12" above the regional average snow fall, whichever is greater.
- Clearances for the sides and back of the outdoor unit must be at least 10" more than standard installation guidelines.
- On-site assembly required see installation manuals provided within each box.

SPECIFICATIONS:

Model Number	Description	Shipping Weight	Shipping Dimensions (H x W x D) (Unit: in.)
PFR-12-18	Front Wind Guard (Per box)	5.9 kg (13 lbs.)	21.2 x 21.5
PRE-12-18	Rear Wind Guard (Per box)	4.9 kg (11 lbs.)	21.2 x 17
PSD-12-18	Side Wind Guard (Per box)	3.2 kg (7 lbs.)	13 x 17
PBK-12-18	Blocker (Per box)	0.9 kg (2 lbs.)	0.5 x 8 x 25

Note: Mitsubishi Electric (MESCA) is not responsible for meeting all requirements of the Contract Documents. The Contractor is responsible for dimensions to be confirmed and correlated at the job site, for information that pertains solely to fabrication processes or to techniques of construction and installation and for co-ordination of the work of all sub-trades.

REVIEWED
 REVIEWED AND MODIFIED
 REVISE AND RESUBMIT
 NOT REVIEWED

The review by JRP Engineering is for the sole purpose of ascertaining conformance with the general design concept. This review shall not mean the detail design inherent in the shop drawings are approved responsibility of which shall remain with the Contractor submitting same and review shall not relieve the Contractor of this responsibility for errors or omissions in the shop drawings or his responsibility for meeting all requirements of the Contract Documents. The Contractor is responsible for dimensions to be confirmed and correlated at the job site, for information that pertains solely to fabrication processes or to techniques of construction and installation and for co-ordination of the work of all sub-trades.

JRP Engineering
 M. Karakolis

DATE: March 31st, 2017

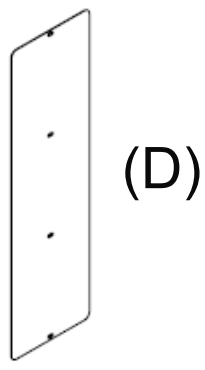
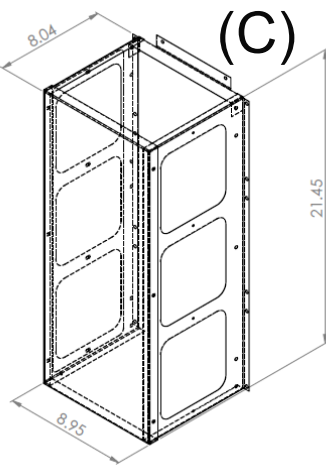
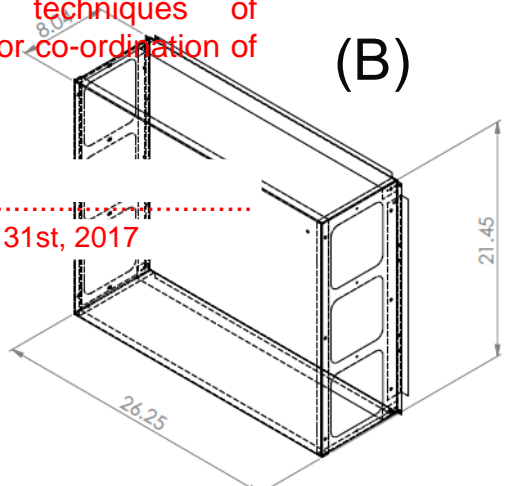
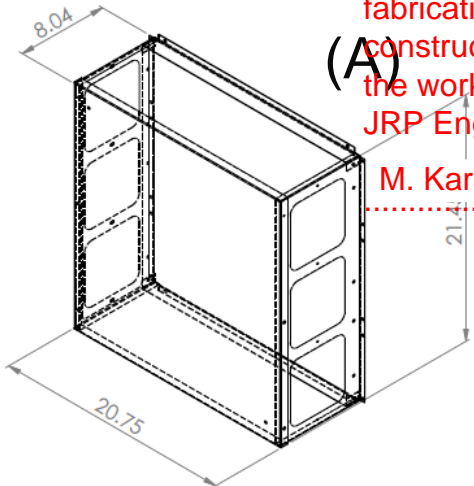

Notes:

Specifications are subject to change without notice.

"Should this document be altered or changed without MESCA's permission, it becomes null and void. MESCA assumes no responsibility for any consequences in such cases"