



Research Paper

PERFORMANCE ANALYSIS OF VAPOUR COMPRESSION REFRIGERATION SYSTEM WITH R404A, R407C AND R410A

Jyoti Soni^{1*} and R C Gupta¹

*Corresponding Author: **Jyoti Soni**, ✉ Jyoti.soni45@gmail.com

This paper provides a detailed exergy analysis for theoretical vapour compression refrigeration cycle using R404A, R407C and R410A. The equations of exergetic efficiency and exergy destruction for the main system components such as compressor, condenser expansion device, liquid-vapour heat exchanger and evaporator are developed. The relations for total exergy destruction in the system, the overall exergetic efficiency of the system and Exergy Destruction Ratio (EDR) related to exergetic efficiency are obtained. Also, an expression for Coefficient of Performance (COP) of refrigeration cycle is developed. The investigations shows that various results are obtained for the effect of evaporating temperatures, condensing temperatures, degree of subcooling and effectiveness of liquid-vapour heat exchanger on COP, exergetic efficiency and EDR of theoretical vapour compression refrigeration cycle.

Keywords: Exergetic analysis, Refrigeration system, Modelling, R404A, R407C, R410A

INTRODUCTION

In the past decades, the Ozone Depletion Potential (ODP) and Global Warming Potential (GWP) have become the dominant environmental issues, caused by the leakages of the CFC and HCFC refrigerants. The Montreal protocol (UNEP, 1997) declared the phasing out of CFC's and HCFC's as refrigerants that deplete the ozone layer (ODP) (UNEP, 1997). The Kyoto protocol (UNFCCC, 2011) encouraged promotion of

rules for sustainable development and reduction of Global Warming Potential (GWP) including the regulations of HCFC's (United Nations, 2011). Both of CFC and HCFC have high ODP and GWP. Because of their high GWP, alternatives to refrigerants CFC and HCFC such as azeotropic mixtures refrigerants with their zero ODP have been preferred for use in many industrial and domestic applications intensively for a decade.

¹ Jabalpur Engineering College, Gokulpur, Ranjhi, Jabalpur 482011, Madhya Pradesh, India.

Various researches have suggested different HC, HFC and HCFC blends as potential substitutes for CFCs and compared the performance of these substitutes either theoretically or experimentally. Douglas *et al.* (1999) describes the development and application of a cost-based method for comparing alternative refrigerants applied to R22 systems. A computational model based on this method was used to analyze the performance of several leading R22 replacements candidates for window air conditioners. From the investigations it was revealed that for the optimized systems, all the alternatives had system costs that were within about 4% of those for R22. Also, differences between most of the alternative refrigerants were smaller than the uncertainties in the analysis. Havelsky (2000) conducted an experimental analysis for R12 replacements with the influence on energy efficiency and global warming expressed by the values of Coefficient of Performance (COP) and Total Equivalent Warming Impact (TEWI). Presented Experimental analysis, relate the use of refrigerants R134a, R401A, R409A, R22 and the mixture of R134a with R12 to the values of COP and TEWI of refrigerating system in comparison with R12 application. Their results showed that the use of R134a, R401A and R409A refrigerants enables the values of TEWI in comparison with R12 application. Aprea and Greco (2002) presents an experimental investigation for R22 replacements in vapour compression plant with most widely used drop-in substitute i.e. the zeotropic mixture R407C. The experimental analysis was carried out with the help of exergetic approach. The exergetic performance of the individual components of the plant has been analyzed,

in order to pinpoint those contributing most to the decrease in the exergetic performance of R407C. Aprea *et al.* (2004) conducted an experimental analysis to study the performances of a vapour compression plant working both as a water chiller and as a heat pump, using as refrigerant fluids R22 and its substitute R417A. The results revealed that R22 gives best performances in comparison with R417A in terms of COP, exergetic efficiency and exergy destroyed in the components. Akhilesh and Kaushik (2008) present a detailed exergy analysis of an actual vapour compression refrigeration cycle. A computational model has been developed for calculating the COP, exergetic efficiency, exergy destruction and efficiency defects for R502, R404A and R507A. The results of this investigations revealed that R507A is a better substitutes to R502 than R404A. Comakli *et al.* (2009) experimentally investigated the effects of gas mixture rate, evaporator air inlet temperature (from 24 to 32), evaporator air mass flow rate (from 0.58 to 0.74), condenser air inlet temperature (from 22 to 34) and condenser air mass flow rate (from 0.57 to 0.73) on the COP and the exergetic efficiency values of vapour compression heat pump systems. The investigation has been done for refrigerants R22 and R404A five of their binary mixtures which contain about 0%, 25%, 50%, 75% and 100% mass fractions of R404A were tested. It was observed that the most effective parameters are found to be condenser air inlet temperature on COP and exergetic efficiency. Miguel *et al.* (2010) presents an exergy analysis of the impact of direct replacements (retrofit) of R12 with the zeotropic mixture R413a on the performance of a domestic vapour compression refrigeration system,

originally designed to work with R12. The results of this experimental investigation showed that overall energy and exergy performance of the system working with R413A is consistently better than that of R12. Venkataramanmurthy and Senthil (2010) conducted an experimental test for the analysis the comparisons of energy, exergy flow and second law efficiency of R22 and its substitutes R-436b in vapour compression refrigeration system. The investigations present the effects of the evaporating temperatures on the exergy flow losses and second law efficiency and coefficient of performance of a vapour compression refrigeration cycle. Bilal and Syed (2011) investigated performance degradation due to fouling in a vapour compression cycle for various applications. For the analysis consider the two sets of refrigerants depending upon the assumption and their some properties. Considering the first set of refrigerants R134a, R410A and R407C while second set include the refrigerants of R717, R404A and R290. From a first law standpoint, the COP of R134a always performs better than R410A and R407C unless only the evaporator is being fouled. From a second law standpoint, the second law efficiency of R134a performs the best in all cases. From a first law standpoint, the COP of R717 always performs better than R404A and R290 unless only the evaporator is being fouled. From a second law standpoint, the second law efficiency of R717 performs the best in all cases. Volumetric efficiency of R410A and R717 remained highest under all the respective conditions. Furthermore, performance degradation of evaporator has larger effect on compressor power

consumption while the performance degradation of condenser has larger effect on COP of the vapour compression cycle.

In this paper exergetic approach is used to analysis the performance of theoretical vapour compression refrigeration cycle using R404A, R407C and R410A. The equations of exergetic efficiency and exergy destruction for the main system components such as compressor, condenser expansion device, liquid-vapour heat exchanger and evaporator are developed. The relations for total exergy destruction in the system, the overall exergetic efficiency of the system and EDR related to exergetic efficiency are obtained. Also, an expression for COP of refrigeration cycle is developed. This investigations shows that results are obtained for the effects of evaporating temperatures, condensing temperature, degree of subcooling and effectiveness of liquid-vapour heat exchanger on COP, exergetic efficiency and EDR of theoretical refrigeration cycle. Commonly, simple vapour compression refrigeration systems are used for comfort cooling and cold storage application. Depending upon the applications evaporating temperature varies from $-50\text{ }^{\circ}\text{C}$ to $7\text{ }^{\circ}\text{C}$ (Bilal and Syed, 2011). The scientists investigate more environmentally friendly refrigerants to resolve the problems of ODP and GWP. Currently, the following three refrigerants are being used as alternatives to CFC in various applications: R404A, R407C and R410A. Though, these three refrigerants are completely harmless to ozone layer, but sometimes they can add to global warming due to their leaks. The main characteristics of the tested refrigerants as shown in Table 1.

Table 1: The Main Characteristics of the Tested Refrigerants

| Refrigerant | R404A | R407C | R410A |
|---------------------------------------|---------|---------|---------|
| Molar Mass | 97.60 | 86.20 | 72.58 |
| Boiling Point (°C) | -46.45 | -43.56 | -51.6 |
| Critical Temperature (°C) | 72.07 | 86.74 | 72.5 |
| Critical Pressure (bar) | 3.7315 | 4.6191 | 4.95 |
| Critical Density (kg/m ³) | 484.5 | 527.30 | 500 |
| Critical Volume (m ³ /kg) | 0.00206 | 0.00190 | 0.00205 |
| Ozone Depletion Potential | 0 | 0 | 0 |
| Global Warming Potential | 3859 | 1526 | 1725 |
| Certainty Class | A1 | A1 | A1 |

Source: Mohanraj et al. (2009)

EXERGY ANALYSIS

A modified vapour compression refrigeration system consists of five components such as evaporator, liquid-vapour heat exchanger, compressor, condenser and expansion device. All the components connected in a closed loop through piping that has heat transfer with the surrounding can be shown in Figure 1. At point 11, refrigerant leaves the evaporator at a low pressure, low temperature, saturated vapour and enter the liquid vapour heat exchanger where it absorbs the heat from high pressure-temperature refrigerant flows from the condenser. At state 1, the refrigerant from the liquid-vapour heat exchanger enter into compressor through the suction line where both temperature and pressure increases. This process can be shown in Figure 2. At state 2, it leaves the compressor at a high pressure, high temperature, superheated vapour conditions and enter the condenser where it reject heat to surrounding medium at constant pressure after undergoing heat transfer in the discharge line. Refrigerant leaves the condenser at state 3, as a high pressure, medium temperature, saturated liquid and

enter the liquid-vapour heat exchanger at state 33, where it rejects the heat to low pressure-temperature refrigerant. The expansion device allows to flowing the liquid refrigerant at constant enthalpy from high pressure to low pressure. At state 4, it leaves the expansion valve as a low temperature, low pressure, and liquid-vapour mixture and enters the

Figure 1: Schematic of Typical Vapour Compression Refrigeration System with a Liquid-Vapour Heat Exchanger

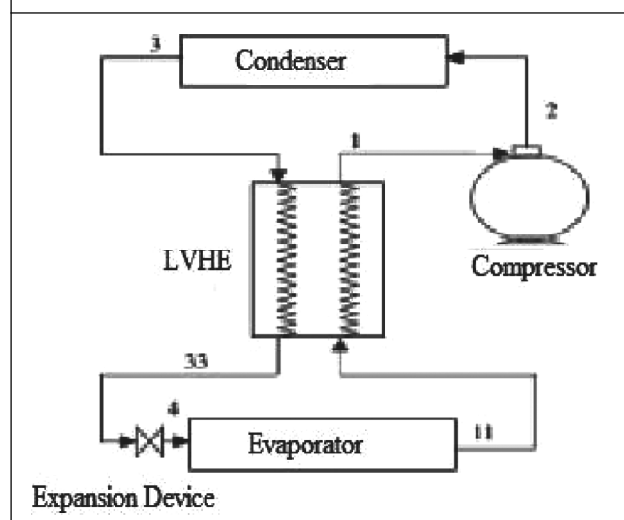
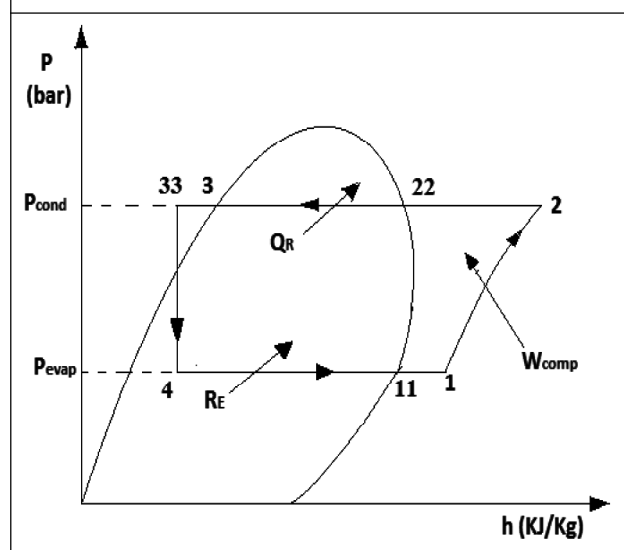

Figure 2: Pressure-Enthalpy Diagram Showing Effect of an Idealized Liquid-Vapour Heat Exchanger



evaporator where it absorbs the heat at constant pressure from the space to be cooled and changed into saturated vapour and cycle is completed.

For analysis the performance of vapour compression refrigeration system, following assumption are made:

- Degree of subcooling of liquid refrigerant in liquid-vapour heat exchanger (ΔT_{sub}) = 5 °C.
- Mechanical efficiency of compressor (η_{mech}) = 75%.
- Electrical efficiency of compressor (η_{el}) = 75%.
- Difference between evaporator and space temperature ($T_r - T_e$) = 20 °C.
- Effectiveness of liquid vapour heat exchanger (ε) = 0.8.
- Evaporator temperature T_{evap} (in °C) ranging from -50 °C to 0 °C.
- Condenser temperature T_{cond} (in °C) = 40 °C, 55 °C.
- Mass flow rate of refrigerant (m_r) = 1 kg/s
- Dead state temperature (T_0) = 30 °C.
- There is no pressure loss in pipelines.
- In all components steady state operations are considered.

The energy analysis based on first law of thermodynamic, the performance of vapour compression refrigeration system can be predicted in terms of Coefficient of Performance (COP), which is defined as the ratio of net refrigerating effect produced by the refrigerator to the work done by the compressor. It is expressed as:

$$COP = \frac{Q_e}{W}$$

$$COP = \frac{h_1 - h_4}{h_2 - h_1} \quad \dots(1)$$

The modern approach based on second law of thermodynamic, i.e., exergy analysis can be used to measure the performance of the vapour compression refrigeration system. This analysis derives the concept of exergy, which is always decreasing due to thermodynamic irreversibilities. Exergy is the maximum useful work that could be obtained from the system at a given state in a specified environment. Exergy balance for a control volume undergoing steady state process is expressed as:

$$E_{d_i} = \sum (me_x)_{in} - \sum (me_x)_{out} + [\sum (Q(1 - T_0/T))_{in} - \sum (Q(1 - T_0/T))_{out}] \pm \sum W \quad \dots(2)$$

Exergy Destruction (ED) in the System Components

Exergy destruction in each component of the cycle is calculated as:

Exergy destruction in Evaporator

$$E_{d_e} = E_{x_4} + Q_e \left(1 - \frac{T_0}{T_r} \right) - E_{x_{11}} = m_r (h_4 - T_0 S_4) + Q_e \left(1 - \frac{T_0}{T_r} \right) - m_r (h_{11} - T_0 S_{11}) \quad \dots(3)$$

Exergy destruction in Compressor

$$E_{d_{comp}} = E_{x_1} + W - E_{x_2}$$

$$= m_r(T_0 S_2) + \frac{W}{\eta_{mech} + \eta_{el}} - m_r(h_2 - T_0 S_2) \quad \dots(4)$$

Exergy destruction in Condenser

$$E_{d_c} = E_{x_2} - E_{x_3} = m_r(h_2 - T_0 S_2) - m_r(h_3 - T_0 S_3) - Q_c \left(1 - \frac{T_0}{T_c}\right) \quad \dots(5)$$

Exergy destruction in Throttle valve

$$E_{d_t} = E_{x_{33}} - E_{x_4} = m_r(h_{33} - T_0 S_{33}) - m_r(h_4 - T_0 S_4) \quad \dots(6)$$

Exergy destruction in liquid vapour heat exchanger

$$E_{d_{ivhe}} = E_{x_1} - E_{x_{33}} + E_{x_{11}} - E_{x_1} = m_r(h_3 - h_{33} + h_{11} - h_1) - T_0(S_3 - S_{33} + S_{11} - S_1) \quad \dots(7)$$

Total Exergy Destruction

Total exergy destruction in the system is the sum of the exergy destruction in different components of the system and is given by

$$\Sigma E_{d_i} = E_{d_e} + E_{d_{comp}} + E_{d_c} + E_{d_t} + E_{d_{ivhe}} \quad \dots(8)$$

Now, total exergy supplied is given by:

$$EF = EP + \Sigma E_{d_i} \quad \dots(9)$$

For refrigeration system, product is the exergy of the heat abstracted into the evaporator from the space to be cooled at temperature T_r i.e.

$$EP = Q_e \left| 1 - \frac{T_0}{T_r} \right| \quad \dots(10)$$

Exergetic Efficiency (η_{ex})

$$\eta_{ex} = \frac{\text{Exergy in product}}{\text{Exergy of fuel}} = \frac{EP}{EF} \quad \dots(11)$$

and exergy of fuel is actual compressor work input, W . Hence exergetic efficiency is given by:

$$\eta_{ex} = \frac{Q_e \left| 1 - \frac{T_0}{T_r} \right|}{W} \quad \dots(12)$$

Exergy Destruction Ratio (EDR)

Exergy destruction ratio is the ratio of the total exergy destruction in the system to the exergy in the product and it is given by

$$EDR = \frac{ED_{total}}{EP}$$

EDR related to the exergetic efficiency given by:

$$EDR = \frac{1}{\eta_{ex}} - 1 \quad \dots(13)$$

RESULTS AND DISCUSSION

Figures 3-4 shows the effects of evaporating temperatures on coefficient of performance. With increase in evaporator temperature, the pressure ratio across the compressor decreases, causing work done by the compressor decrease and cooling capacity increases due to increase in refrigerating effect. Hence, the combined effect of these two factors increases the COP of the vapour compression refrigeration system. R407C presents the maximum COP among all the

refrigerants corresponding to evaporator and condenser temperatures considered. R404A shows better COP than R410A at both condenser temperatures, i.e., at 40 °C and 55 °C. The maximum difference observed between COPs of R404A and R410A is 4.03% at 55 °C at higher end of evaporator temperatures. The COP of R407C is 7-14% higher than the COP for R404A and R410A at 40 °C condenser temperature. This difference is increases to 8-18% at 55 °C condenser temperature.

i.e. , $Q_e \left| 1 - \frac{T_0}{T_r} \right|$. With increase in evaporator temperature Q_e increases whereas the term $\left| 1 - \frac{T_0}{T_r} \right|$ reduces. Second parameter is the compressor work required by compressor W which decreases with increase in evaporator temperature. Both terms Q_e and W have positive effect on increase of exergetic

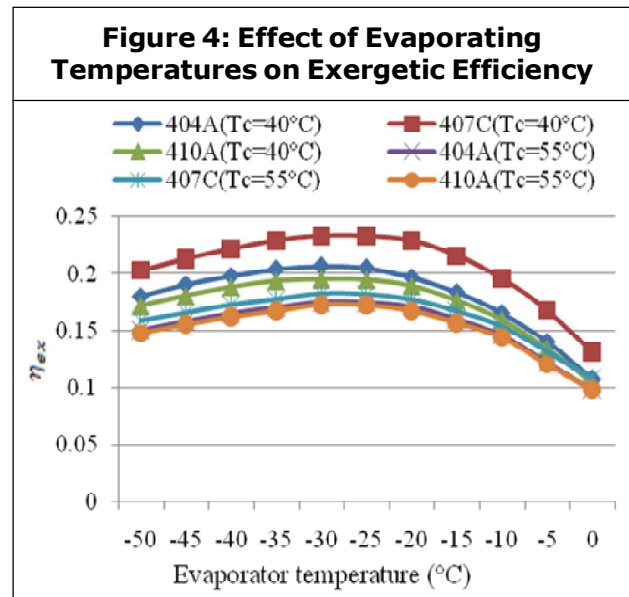
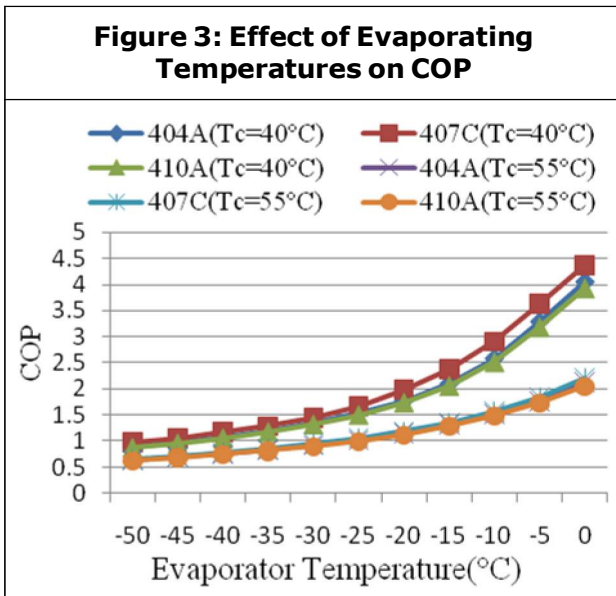

Figures 4-5 shows the effect of evaporator temperatures on exergetic efficiency (η_{ex}) and EDR. With increase in evaporator temperatures exergetic efficiency increases till the optimum evaporator temperature and beyond this optimum temperature it decreases. The optimum evaporator is the temperature at which maximum exergetic efficiency is obtained. The curves trend for EDR almost reverses to curves of exergetic efficiency. The rise and fall of the exergetic efficiency, depends upon the two parameters. First parameter is the exergy of cooling effects,

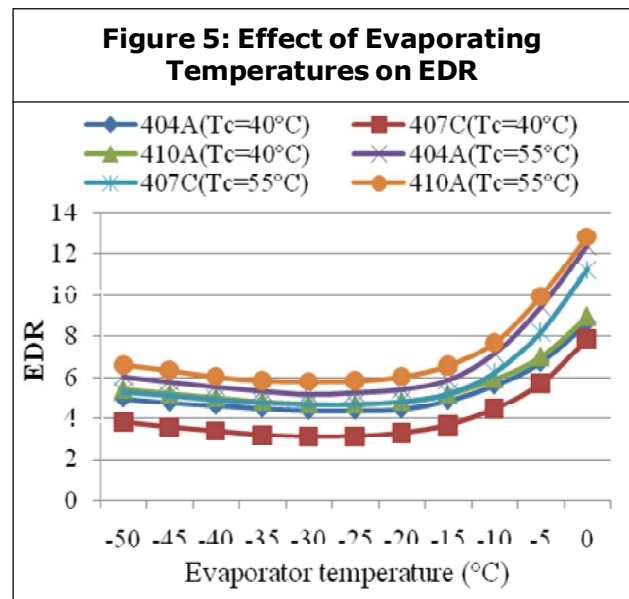

efficiency whereas the term $\left|1 - \frac{T_0}{T_r}\right|$ has negative effect on increase of exergetic efficiency. The combined effects of these two parameters, increases exergetic efficiency till the optimum evaporator temperature and beyond the optimum temperature decrease. Because of exergetic efficiency is inversely proportional to EDR; the curves trend for EDR almost reverses to curves of exergetic efficiency. With increases in evaporating temperatures, EDR decreases till the optimum evaporator temperature and beyond this optimum temperature it increase. The optimum evaporator is the temperature at which minimum EDR is obtained. The exergetic efficiency of R407C is 10-18% higher than R404A and 14-20% higher than R410A at 40 °C condenser temperature. The corresponding values at 55 °C condenser temperature are 13-20% and 15-21% higher, respectively, for R407C. At both 40 °C and 55 °C condensers temperatures, R407C is better than R404A and R410A. It also confirms that with increase in condenser temperature the difference among the exergetic efficiency of R407C, R404A and R410A increases.

Figures 6-8 presents the effect of degree of subcooling on COP, exergetic efficiency and EDR. It is evident that increase in degree of subcooling increases the cooling capacity because of increase in refrigerating effect and there is no change in compressor work, hence COP increases. From the study, it is evident that increase in COP increases the exergetic efficiency and reduces the EDR. The rate of increase in COP is approximately 0.99%/°C, 0.7%/°C, and 0.85%/°C of subcooling in case of R404A, R407C and R410A.

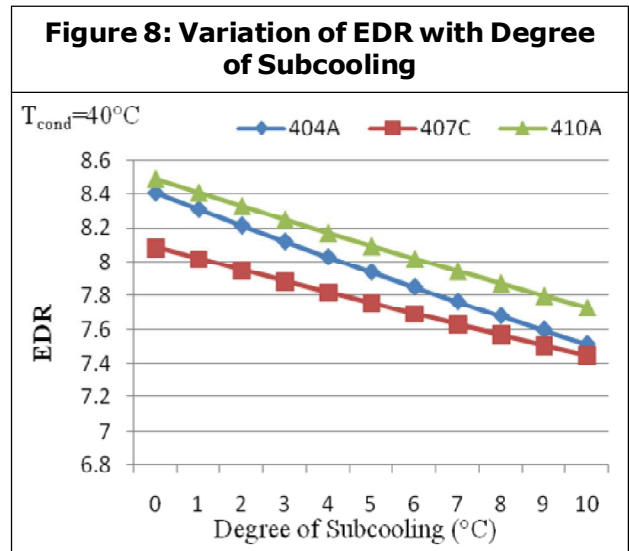
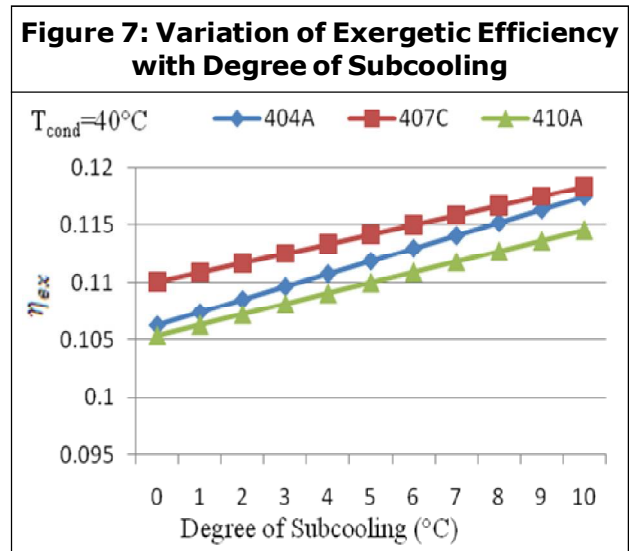
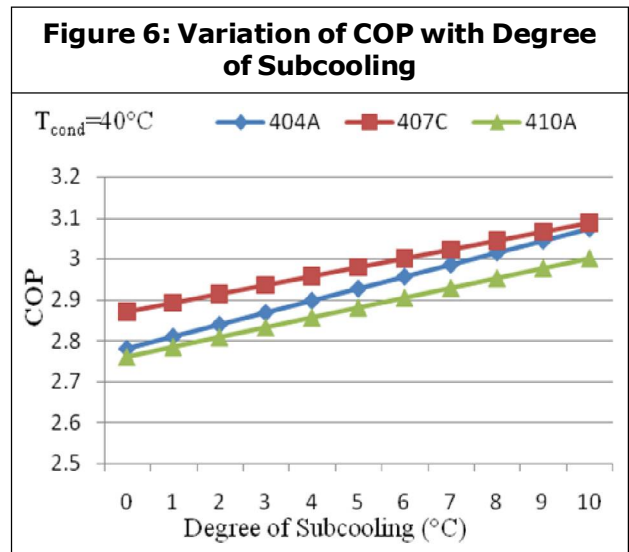

The rate of increase in exergetic efficiency is approximately 1%/ , 0.73%/ and 0.84%/ for R404A, R407C and R410A. The total increase in exergetic efficiency for R404A, R407C and R410A is 10.52%, 7.55% and 8.71% for 10 subcooling

Figures 9-11 shows the effect of effectiveness of liquid-vapour heat exchanger on COP, exergetic efficiency and EDR. With increase in effectiveness of liquid-vapour heat exchanger COP and exergetic efficiency

Figure 9: Effect of Effectiveness of Liquid-Vapour Heat Exchanger on COP

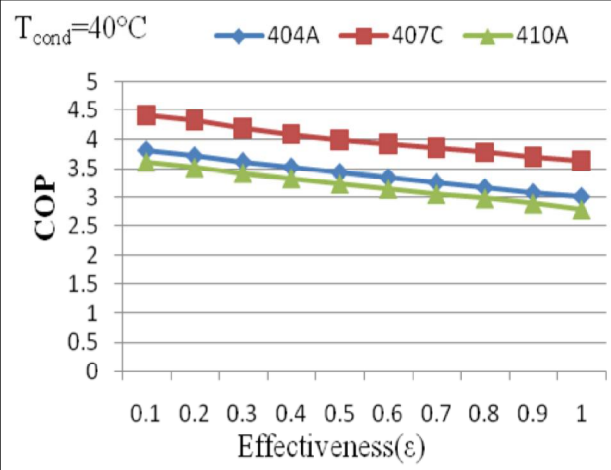

Figure 10: Effect of Effectiveness of Liquid-Vapour Heat Exchanger on Exergetic Efficiency

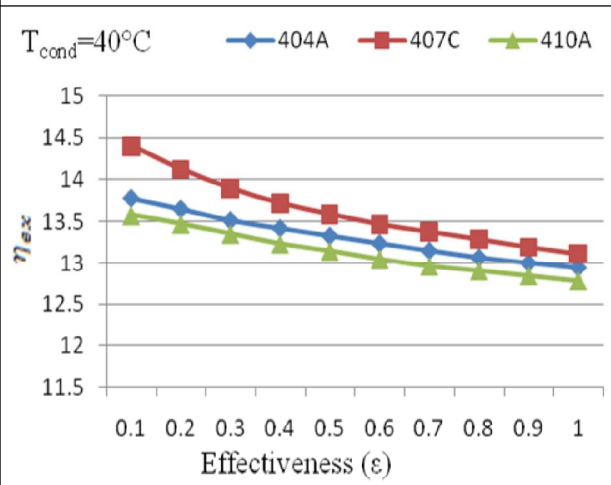
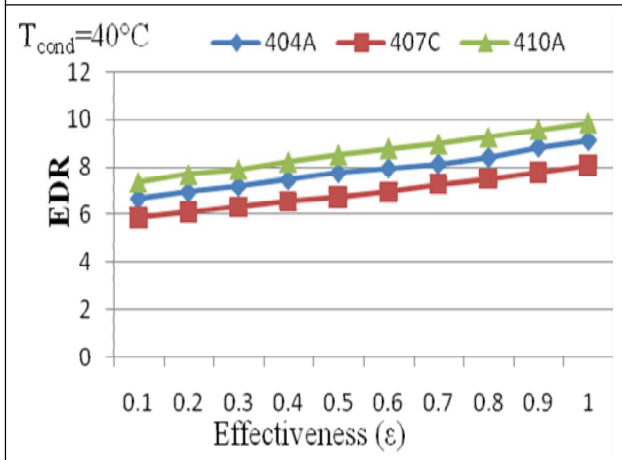

Figure 11: Effect of Effectiveness of Liquid-Vapour Heat Exchanger on EDR



reduces whereas EDR increase. The total COP decreases by 17.39% and exergetic efficiency decreases by 9.05% for R407C. The total COP decreases by 22.82% and exergetic efficiency decreases by 5.85% for R410A. The total COP decreases by 20.91% and exergetic efficiency decreases by 6.05% for R404A.

CONCLUSION

A computational model based exergy analysis is presented for the investigation of the effects of evaporating temperatures, condenser temperature, degree of subcooling, and effectiveness of the liquid vapour heat exchanger on the COP, exergetic efficiency and EDR of the vapour compression refrigeration cycle for R404A, R407C and R410A. The conclusions present in this analysis are given as follows:

- The COP and exergetic efficiency of R407C are better than that of R404A and R410A. The EDR of R410A is higher than that of R407C and R404A. This analysis performed at condenser temperatures 40 °C and 50 °C and evaporator temperature ranging from 50 °C to 0 °C.

- For all refrigerants, i.e., R404A, R407C and R410A, COP and exergy efficiency improve by subcooling of high pressure condensed liquid refrigerant. The rate of increase in COP is approximately 0.99%/°C, 0.7%/°C, and 0.85%/°C of subcooling in case of R404A, R407C and R410A. The rate of increase in exergetic efficiency is approximately 1%/°C, 0.73%/°C and 0.84%/°C for R404A, R407C and R410A. The total increase in exergetic efficiency for R404A, R407C and R410A is 10.52%, 7.55% and 8.71% for 10 °C subcooling.
- With increase in dead state temperatures exergetic efficiency increases and EDR reduces while coefficient of performance remains constant. The curves trends of all refrigerants are identical and their curves for both exergetic efficiency and EDR are nearly overlapping. The exergetic efficiency of R-407C is 0.3-0.85% higher than R404A and 1.8-2.6% higher than R410A for considered range of dead state temperatures.
- With increase in effectiveness of liquid-vapour heat exchanger COP and exergetic efficiency decreases while EDR increases. The total COP decreases by 17.39% and exergetic efficiency decreases by 9.05% for R407C. The total COP decreases by 22.82% and exergetic efficiency decreases by 5.85% for R410A. The total COP decreases by 20.91% and exergetic efficiency decreases by 6.05% for R404A. ●

REFERENCES

1. Akhilesh Arora and Kaushik S C (2008), "Theoretical Analysis of a Vapour Compression Refrigeration System with R502, R404A and R507A", *International Journal of Refrigeration*, Vol. 31, pp. 998-1005.
2. Aprea C and Greco A (2002), "An Exergetic Analysis of R22 Substitution", *Applied Thermal Engineering*, Vol. 22, pp. 1455-1469.
3. Aprea C, Mastrullo R and Renno C (2004), "An Analysis of the Performance of a Vapour Compression Refrigeration Plant Working Both as a Water Chiller and a Heat Pump Using R-22 and 417A", *Applied Thermal Engineering*, Vol. 24, pp. 487-499.
4. Bilal Ahmed Qureshi and Syed M Zubair (2011), "Performance Degradation of a Vapour Compression Refrigeration System Under Fouled Conditions", *International Journal of Refrigeration*, Vol. 34, pp. 1016-1027.
5. Comakli K, Simsek F, Comakli O and Sahin B (2009), "Determination of Optimum Conditions R-22 and R404a Refrigerant Mixtures in Heat Pumps Using Taguchi Method", *Applied Energy*, Vol. 86, pp. 2451-2458.
6. Douglas J D, Braun J E, Groll E A and Tree D R (1999), "A Cost Method Comparing Alternative Refrigerant Applied to R-22 System", *International Journal of Refrigeration*, Vol. 22, pp. 107-125.
7. Havelky V (2000), "Investigation of Refrigeration System with R12 Refrigerant Replacements", *Applied Thermal Engineering*, Vol. 20, pp. 133-140.
8. Miguel Padilla, Remi Revellin and Jocelyn Bonjour (2010), "Exergy Analysis of

- R413A as Replacement of R12 in a Domestic Refrigeration System”, *Energy Conversion and Management*, Vol. 51, pp. 2195-2201.
9. Mohanraj M, Jayaraj S and Muraleedharan C (2009), “Environment Friendly Alternatives to Halogenated Refrigerants—A Review”, *International Journal of Greenhouse Gas Control*, Vol. 3, pp. 108-119.
 10. United Nations (2011), Kyoto Protocol to the United Nations Framework Convention on Climate Change, available at <http://untccc.int//resource/docs/convkp/kpeng.pdf>
 11. United Nation Environment Programme (UNEPs) (1997), The Montreal Protocol on Substances that Deplete the Ozone Layer.
 12. Venkataramanamurthy V P and Senthil Kumar P (2010), “Experimental Comparative Energy, Exergy Flow and Second Law Efficiency Analysis of R22, R436b Vapour Compression Refrigeration Cycles”, *International Journal of science and Technology*, Vol. 2, No. 5, pp. 1399-1412.
-

APPENDIX

Nomenclature

| | |
|------------|----------------------------------------------|
| COP | Coefficient of performance (non-dimensional) |
| EF | Exergy rate of fuel (kW) |
| E_L | Thermal exergy loss rate (kW) |
| W | Work rate (kW) |
| EDR | Exergy destruction ratio (non-dimensional) |
| s | Entropy (kJ/kg K) |
| ΔP | Pressure drop (bar) |
| E_d | Exergy destruction rate (kW) |
| EP | Exergy rate of product (kW) |
| E_x | Exergy rate of refrigerant (kW) |
| h | Enthalpy (kJ/kg) |
| T | Temperature (K) |

Greek Notations

| | |
|------------------|----------------------------------------------------------|
| η_{ex} | Exergetic Efficiency |
| ε | Effectiveness of the liquid vapour heat exchanger |
| ΔT_{sub} | Degree of subcooling of liquid refrigerant in lvhe (K) |
| ΔT_{sup} | Degree of superheating of vapour refrigerant in lvhe (K) |

Subscripts

| | |
|-----|------------------------|
| C | Condenser |
| R | Space temperature |
| E | Evaporator temperature |

Compressor

| | |
|-----|----------------------------|
| T | Refrigerant throttle valve |
| O | Dead state |