

Questions to Ask When Labeling a Carton Using A Label Printer Applicator

A White Paper by Bruce Richards



Introduction

When deciding to label a carton on a new or existing conveyor line there are several things to take into consideration. Where the label is to be applied on the product, line speed, product handling and environment are just a few.

For this paper we will be discussing using a Label Printer Applicator to label a carton on a production line. The basic label printer applicator (LPA) consists of a print engine, a label application module, label unwind and label rewind.

Label formats and data are sent to the print engine from a host PC or other input device to print on the label. There are many off the shelf label creation packages to choose from to create these label formats. Using a PC the label generation software allows for the design of a label, saving the label and sending it to the print engine.

When triggered the printer prints on the label material using either direct thermal technology or using thermal transfer ribbon. SATO, Zebra and Data Max are a few of the top selling print engines to consider. All the print engines mount on the base plate of the applicator the exact same way, using only five bolts.

The first question to ask is where the label is to be applied on the product. Will it be on the side, top, leading panel, trailing panel, around the corner or on two adjacent panels?

Side Apply or Top Apply Labeling

For a side apply type of application, the label is applied on the same side of the product as the applicator is mounted.

For a top apply type of application, the applicator is suspended over the conveyor and applies the label to the top of the product.

The application cycle is described as follows:

1. The product enters the labeling station from a customer supplied source.

2. A label is dispensed onto a Delrin tampjet pad.
3. The product is detected with a photo cell.
4. At a specified time, determined by the photo cell: the tamp cylinder extends towards the product's presented panel.
5. As the tamp pad comes into contact with the product, the label is pressed onto the panel.
6. A blast of air is expelled through the tamp pad to ensure the label adheres to the carton.
7. The tamp pad returns to the home position, ready to receive another label.

The label is delivered to the side panel/top panel by means of a vacuum tamp pad mounted on the end of an air cylinder. The distance from the LPA to the conveyor and the placement of the product on the conveyor determine the required stroke length of the air cylinder. The preferred method is to have the product justified to the labeling side of the conveyor. This keeps the labeling surface in the same location, every time.

Label placement is affected by the line speed and distance to the carton from the applicator. It is best to have the applicator as close to the labeling surface as possible for optimum throughput. The product detector sees the product, sends a signal to the printer applicator to fire. Delays can be introduced to affect the amount of time after triggering before the cylinder is extended, thus fine tuning label placement.

If the distance between the product and applicator varies, a sensor can be mounted to the tamp pad. The sensor can be a close proximity detector or a mechanical switch that is activated by compression. This "smart tamp" then allows the air cylinder to stroke out and stop at the surface of a product that is not a consistent distance from the applicator. It is set to apply the label at the moment it finds the surface and then stop the forward momentum and retract.

The main concern when using the smart tamp is "label drift". If there is a difference in the distance of the carton from the applicator each time, then the label placement will be affected. For example: If a carton is 6 inches away from the applicator and the next carton is 10 inches away, the label on the carton 10 inches away will be placed toward the trailing edge. This is because the carton is traveling forward and the cylinder has 4 more inches to travel before contacting the product. The faster the line speed the more the label drift. This also applies to a top panel application where the applicator is over the conveyor tamping down on different height cartons.

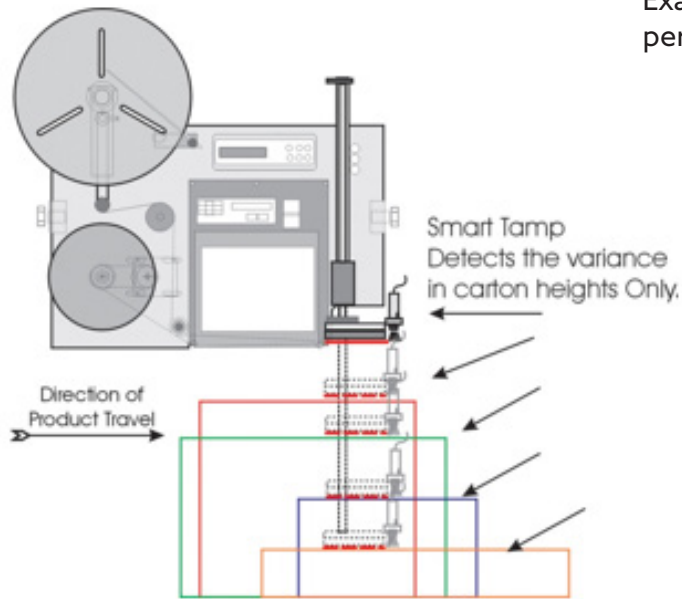

Example of the label drift expected at 65 FPM (feet per minute) can be seen in the table below.

Stroke Variance	Stroke Time (ms)	Label Drift (in)
0	0	0
1	0.05	0.65
2	0.1	1.3
3	0.15	1.95
4	0.2	2.6
5	0.25	3.25
6	0.3	3.9
7	0.35	4.55
8	0.4	5.2
9	0.45	5.85
10	0.5	6.5
11	0.55	7.15
12	0.6	7.8
13	0.65	8.45

The best way to ensure consistent label placement is to index the cartons, stopping them at a specific point on the conveyor system and then triggering the applicator. The smart tamp is still used to control the stroke of the air cylinder

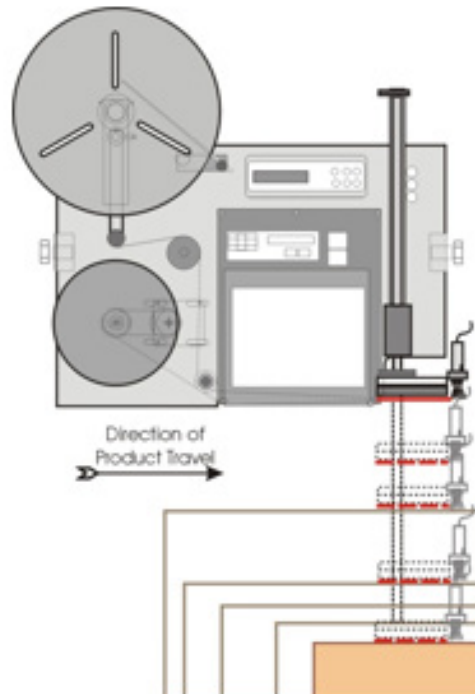

Leading or Trailing Panel Labels

If the requirement is to place a label on the leading or trailing panel of a carton, it can be done either from the side of the conveyor or from over the conveyor. How the carton travels on the conveyor would dictate which method is better suited.

The application cycle is described as follows:

1. The product enters the labeling station from a customer supplied source.
2. A label is printed and dispensed on to a vacuum tampjet pad.
3. A product is detected with a photo cell.
4. At a specified time, determined by the photo cell: the tamp cylinder extends and swings out and around towards the product's leading or trailing panel.
5. As the product comes in contact with the tamp pad, the label is pressed onto the panel of the presented product.
6. A blast of air is expelled through the tamp pad to ensure the label adheres to the carton.
7. The tamp pad returns to the home position and receives another label.

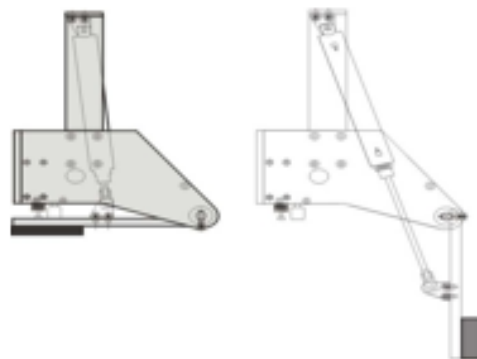

***Swing-Arm Tamp
Application Module***

When the applicator receives a product detect signal, the tamp pad swings out away from the printer applicator and into the path of the carton. The tamp pad is mounted to an arm that is hinged at a specified distance away from the tamp pad. The distance from the hinge to the outer end of the label indicates the length of the swing arm (See Figure 3). Timing is set so that the carton meets the label at the apex of the swing. The label is pressed onto the carton's surface then the arm retracts to the home position to receive the next label.

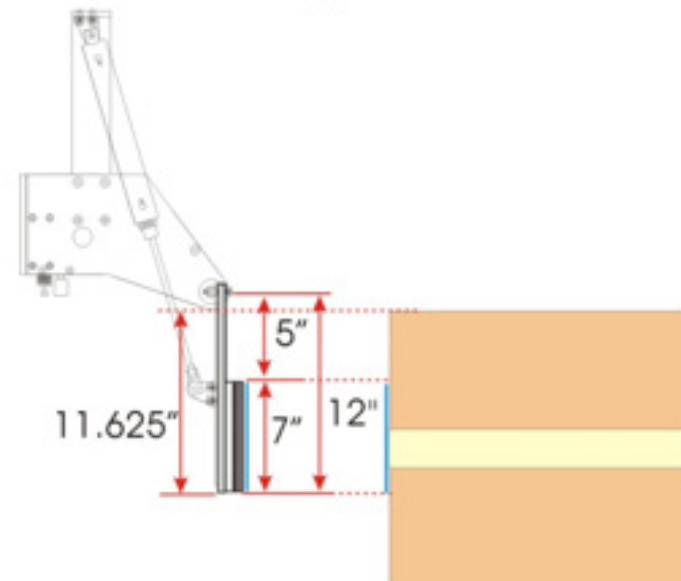

When the application calls for the LPA to be mounted to the side of the conveyor, the product needs to be justified as close to the applicator side of the conveyor as possible.

If product runs centerline then mounting the applicator over the conveyor line should be considered. This will allow the label to be applied centerline, relative to the conveyor. The swing arm reach would be determined by the height of the tallest carton and the placement of the label in relation to the top of the conveyor bed.

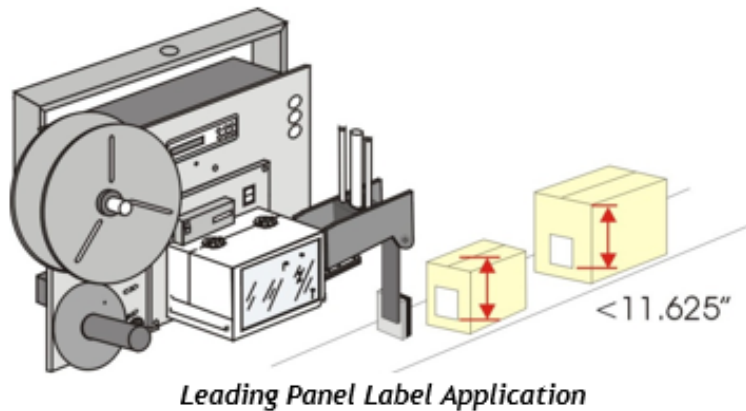

Leading Edge Corner Wrap Labeling

“Corner Wrap” labeling is the process of applying one label across two adjacent panels of a box. Leading Edge Corner Wrap labeling involves applying a label to the leading edge panel and the side or top panel of a carton.

The application cycle is described as follows:

1. The product enters the labeling station from a customer supplied source.
2. A corner wrap module with a vacuum grid is suspended from the applicator into the path of the carton traveling along a conveyor.
3. A label is printed and dispensed onto the vacuum grid such that half (or the leading panel portion of the label) is in front of the carton.

4. The carton travels down the conveyor and meets the corner wrap module.
5. The carton makes contact with the label. The end of the label is positioned at the apex of a spring loaded roller. The rest of the label is set back from the cartons surface by a small lip mounted at the bottom of the cornerwrap module. The forward momentum of the carton applies the end of the label (pinched between the roller and carton’s surface) to the leading panel.
6. The vacuum grid module is pushed back and out of the way as the roller lays the label down and around the corner to the adjacent panel.
7. The spring loaded module returns to home position after the carton passes.

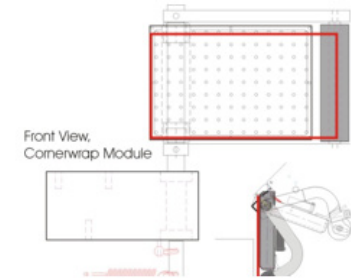

This type of corner wrap system works well for lines up to approximately 85 FPM. To achieve consistent label placement, all cartons must be oriented to the applicator side of the conveyor. This same machine can also be used to apply a label to the leading and top panel by mounting the applicator over the production line.

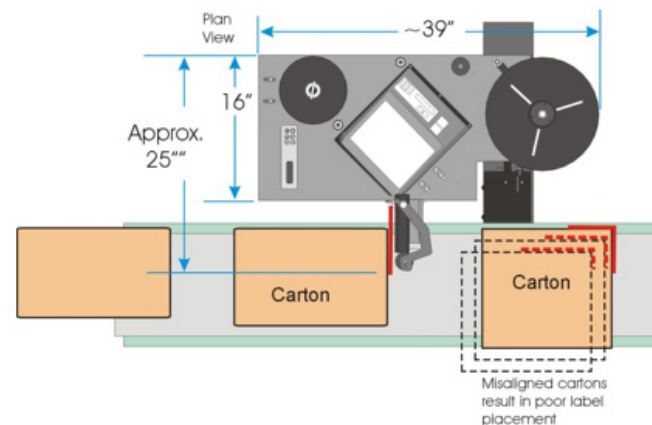

Trailing Edge Corner Wrap Labeling

Side and trailing edge or top and trailing edge corner wrap labeling involves tamping the label onto the side/top panel and using a mounted secondary brush to complete the label application.

As the label is tamped onto the carton, a portion of the label is flagged off the trailing edge. A second product detector triggers the wipe down brush to extend and wipe the label down and onto the trailing panel of the box.

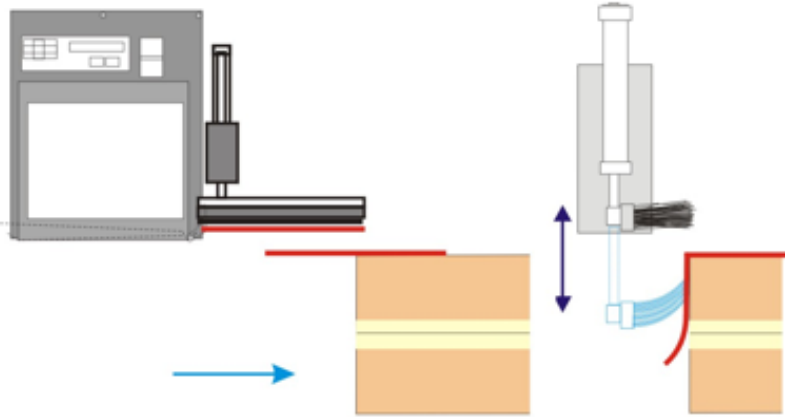

Trailing Edge Corner Wrap Label Application

Dual Panel Labeling

When applying two separate labels on adjacent panels of a carton, it is called "Dual Panel" labeling. The majority of applications will call for leading and side panel or side and trailing panel labeling. However, this method can also be used to perform a leading and top or top and trailing panel label application.

The application cycle is described as follows:

1. The product enters the labeling station from a customer supplied source.
2. A label is dispensed onto a Delrin tampjet pad.
3. A product is detected with a photo cell.

4. At a specified time, determined by the photo cell, the tamp cylinder extends and swings out and around towards the product's leading panel.
5. As the product comes in contact with the tamp pad, the label is pressed onto the leading panel of the presented product.
6. A blast of air is expelled through the tamp pad to ensure the label adheres to the carton panel.
7. The tamp pad returns to the home position and receives another label.
8. The product is detected by a second photo cell.
9. At a specified time, determined by the photo cell, the tamp cylinder extends straight out towards the product
10. The label is pressed onto the side panel of the carton
11. as the tamp pad starts to compress onto the side panel, a smart tamp sensor triggers the module to retract
12. a blast of air is expelled through the tamp pad to ensure the label adheres to the carton panel
13. tamp module returns to the home position

The same scenario would be used for a side and trailing panel application with the side panel being applied first.

In the case of contract packing lines, some cartons require a leading panel label while others only require a side panel label. The dual panel offers the ability for an either/or function.

Configuration is controlled through a photocell selector switch that energizes the desired product detector. The operator can configure the labeling sequence by selecting the appropriate switch. The options are:

- leading panel only
- side panel only apply
- leading and side panel
- no label

The dual panel labeling module is a combination of a swing arm tamp module and a straight tamp module. Two cylinders are used, one completes the swing tamp application while another extends the tamp straight out to the product.

Successful label application requires justifying the product toward or under the labeling station. For top label application, the applicator must be mounted over the conveyor and positioned directly above the flow of product. Height is adjustable to a distance set to accept the label and the applicator swing arm stroke. The application is fixed to accommodate label application on a product that is positioned in the same spot on the conveyance system each time.

For any of the above applications there are choices for the orientation of the applicator. The applicator can be in reels up, reels out, nose up or nose down configuration to accommodate a label being applied in either a portrait or landscape orientation.

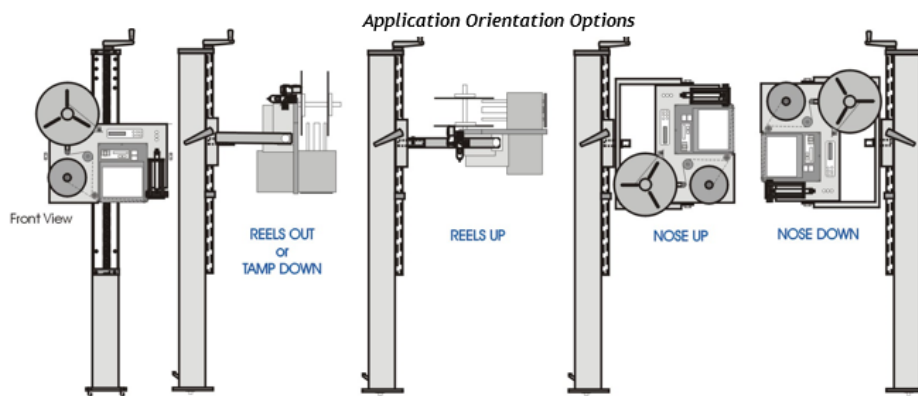

The next consideration is the speed the carton will be traveling and how fast the label needs to be applied. The throughput of a label printer applicator is dependent on the label size, the amount of information that is being printed on the label, line speed and the distance of the product from the applicator.

For example a 2" stroke printer applicator, printing on a 6" long label at 10ips (inches per second) can apply approximately 60 labels per minute. That is the maximum number of labels that can be dispensed and then stroked out 2". But can that many products be presented to the applicator in that time frame?

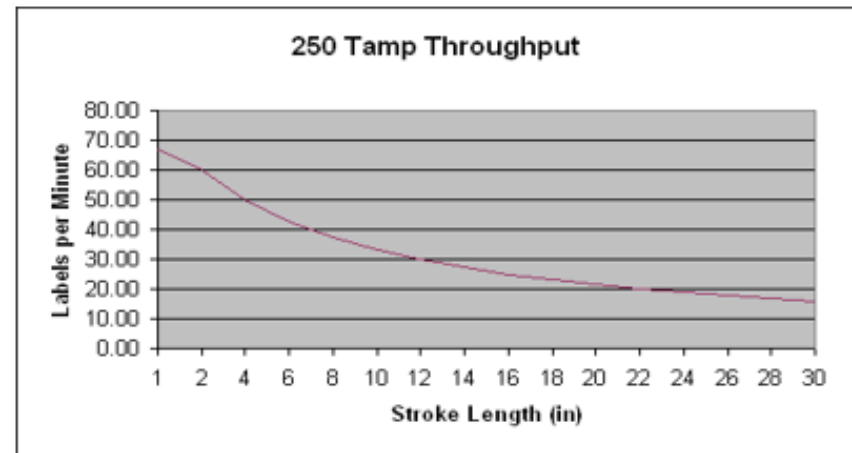

Line speed and product handling are a major factor in determining the ultimate throughput of labeled products. To obtain 60 PPM (products per minute) a 12" long carton would travel at 60 FPM. However, there must be a gap between products so that the product detector can sense the product and trigger the printer applicator to apply the label.

Line speed and product handling are a major factor in determining the ultimate throughput of labeled products. To obtain 60 PPM (products per minute) a 12" long carton would travel at 60 FPM. However, there must be a gap between products so that the product detector can sense the product and trigger the printer applicator to apply the label.

Other considerations include; air and electrical requirements. Most LPAs require plant air. The machines operate on 4 CFM clean dry air. Three stage filters are often used to supplement plant air dryers and filters. Tamp cylinders operate in the 40 to 70 psi range.

110VAC is the typical power requirement. The power supply of the printer applicator should be auto sensing so that 220VAC will not damage the unit. The print engine generally takes its power from the applicator so that one 110V outlet should be enough. Peripherals that are powered or have air driven cylinders will require their own electrical/air connections.

Can Product Detectors be mounted to the conveyor? Product detectors sense the product and send a signal to the applicator to commence the labeling cycle. The detector is generally mounted on the conveyor.

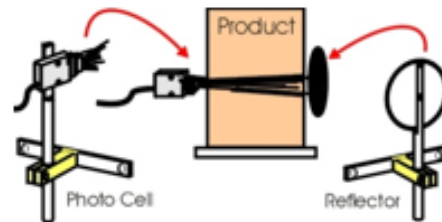

Can the base of the T-base stand holding the applicator fit under the current conveyor? A typical portable stand base, with the weldment, casters and leveling pads, is about 8.5" tall.

Is there adequate line space for the label printer applicator? The typical printer applicator is less than 30" in length alongside a conveyor. The portable stand is 3" X 5" tubing, approximately 48" wide by 40" deep.

As an option, there are permanent mounting plates that take up less room but require bolting to the floor.

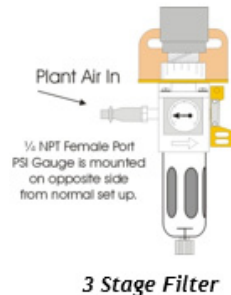

What is the Top of Bed (TOB) height? This is the distance from the conveyor bed to the floor. Conveyors running at a TOB of under 20" may require custom mounting in order to place the applicator that close to the floor.

The vertical mounting column comes in various heights and has adapters for when the conveyor bed is above 60" TOB. If the applicator is mounted high above the floor, accommodations must be made to load media or access the applicator controls. Portable ladders or a platform should be considered.

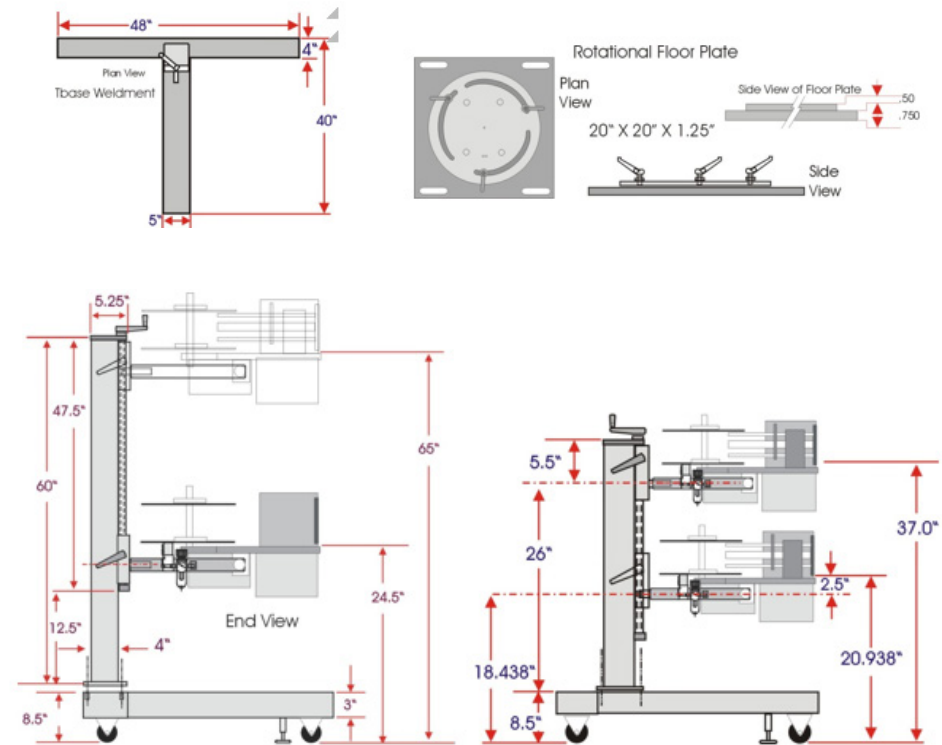

Applicator Mounting Options

These are just some of the questions to ask when planning to use a label printer applicator to print and apply a label to a carton. An ID Technology Labeling, Coding and Marking Specialist can perform a site survey and recommend the best solution for a specific application.

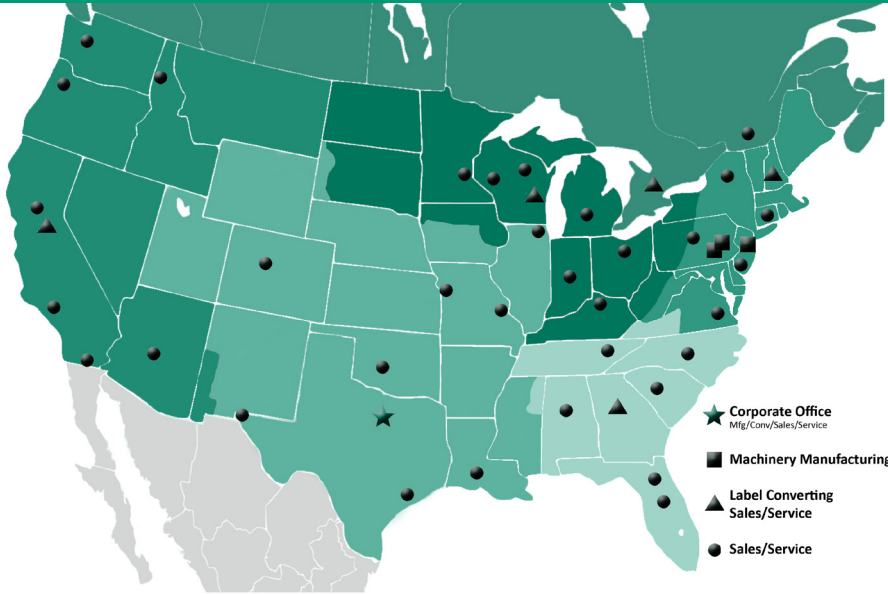

Shaded regions represent areas served by our Label Converting Facilities

Nationwide Service & Support

We pride ourselves in providing responsive nationwide customer service and support from any of our 17 regional sales, service and stocking facilities.

ID Technology technicians are PMMI Certified Trainers to ensure the highest standards of quality training are being met and unparalleled value is being given to the customer.

Our field service personnel are factory trained to service and support our full range of labeling, coding and marking equipment.

In addition to the field service team, ID Technology employs factory trained bench service technicians to accommodate timely depot service.

ID Technology boasts six label converting plants across the US and Canada that produce top quality labels and tags with local support.



*Complimentary Limited
Lifetime Equipment Warranty*

For customers using ID Technology labels with our labeling systems, we provide a lifetime limited equipment warranty free of charge. Just ask us for details!

ID TECHNOLOGY®

5051 North Sylvania Avenue, Suite 405
Fort Worth, TX 76137
P: 888-438-3242