

# BUSH HOG®



*Performance  
You Can  
Count  
On™*

## BOOM MOWERS

PT5 & RMB SERIES | SM60



**Built**  
**BUSH**  
**HOG**  
**TOUGH**  
in Selma Alabama



PT5 & RMB SERIES

## **REAR MOUNTED BOOM MOWERS**



### **Extend your reach and productivity!**

The ultimate in versatility, Bush Hog®'s rugged tractor-mounted boom mowers are designed to trim trees, brush, or hedges and mow behind guardrails, over fences, down embankments, and around ponds. With four models reaching 11 to 18 feet from the tractor centerline, there's almost no limit to what you can accomplish. They're easy to operate and built to provide years of dependable service.

## **Bush Hog®'s Boom Mowers Take Cutting to New Heights.**

Our dependable, rugged boom mowers are a valuable management tool for towns, cities, farmers, and landowners with acreage.

Four models cover a wide range of applications and tractor sizes.

**(RMB models to be used on tractors equipped with cabs only, and for rotary mower heads, protective screen material must be installed.)**



## REAR MOUNTED BOOM MOWERS



PT5-2

The unique PT5 is powered by the tractor's hydraulic system, requiring only 3.7 gal/min. flow to operate the unit. A Flow Control Valve Kit comes standard on current models to divert excess hydraulic flow back to the tractor. The PT5 fits tractors as small as 15 HP. Its unique "swing over" design enables the unit to work on either side of the tractor. The PT5 is equipped with a swing arm, sickle bar head to meet the pruning needs of horticulturists and landscapers alike.

## Bush Hog® Features

- 🐾 **Multiple cutting head offerings** allow you to fit the RMB Mowers to your particular application. A rotary cutter head capable of cutting brush up to 4 inches in diameter is available for use on the larger RMB1660 and RMB1865(E) models. Flail heads capable of mowing either grass or brush up to 2 inches in diameter, or sickle bar cutters that specialize in trimming hedges and mowing round out the cutting head options.
- 🐾 **RMB models fit tractors as small as 45 engine HP** and weighing a minimum 4,410 lbs.
- 🐾 **Hydraulic breakaway mechanisms** on all RMB models break up and away to allow you to clear most obstacles encountered while mowing.
- 🐾 **RMB1660 and RMB1865 units offer a Power Slew feature** that allows the operator to rotate the cutter 100° to the rear, thereby permitting the cutting out of corners and mowing within the tractor's width.
- 🐾 **Easy-to-use cable control valve bank** for in-cab operation with an optional electronic proportional valve, joystick, controlled system available on the RMB 1865E model. Models offer quick-detach control cables which permit the operator to leave the controls in the cab when the unit is removed for the tractor.
- 🐾 **All flail heads on the RMB models come standard with an adjustable front guard and front flap kit** to protect from thrown objects, along with a built-in "wire trap" feature to keep loose wires from becoming entangled in the rotor.
- 🐾 **RMB models offer optional accessories** such as a lift float kit and skid kit on certain models.

RMB1445-1  
RMB1660-1  
RMB1865-1

*(RMB models to be used on tractors equipped with cabs only.)*

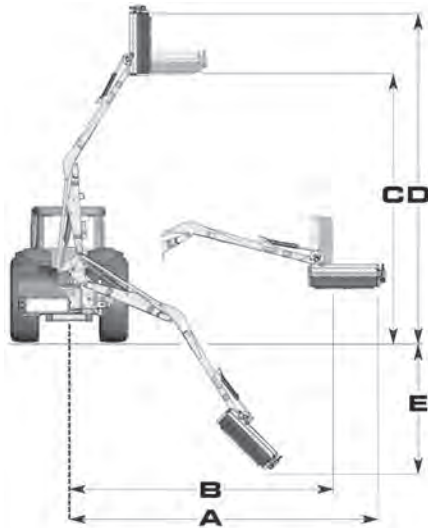

PT5-2  
POWERTRIM  
3/4-inch Cutting Capacity  
59-inches Cutting Width

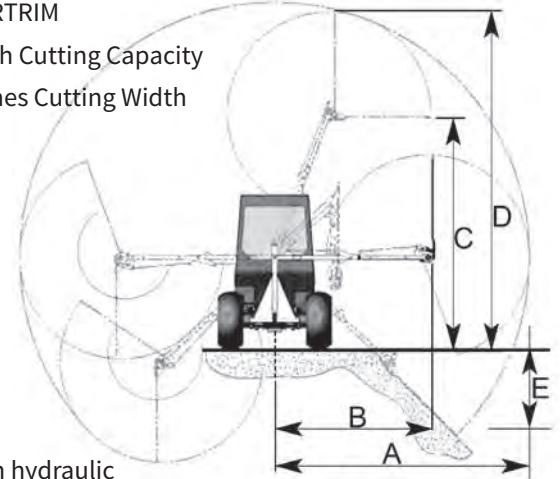

All booms equipped with hydraulic or mechanical breakaway.

## SPECIFICATIONS

Specifications	RMB1445-1	RMB1660-1	RMB1865-1	PT5 Powertrim-2
<b>Tractor Engine HP/Weight(Min.)</b>	See Head Selection Chart; Varies Based on Head Choice			
<b>Tractor PTO</b>	540	540	540	N/A
<b>Machine Weight</b> (Base Unit Only)*	1,348 lbs.	2,322 lbs.	2,392 bs.	430 lbs.
<b>Hydraulic System</b>	Totally Independent	Totally Independent	Totally Independent	Open Center Hydraulics System Only. Tractor Remote Outlet. 3.7 - 5.6 GPM Flow Range Flow Control Valve Kit Comes Standard on Current Models
<b>Attachment Method</b>	Cat. I/II, 3 Pt. Mount	Cat. II, 3 Pt. Mount	Cat. II, 3 Pt. Mount	Cat. I, 3 Pt. Mount
<b>Controls</b>	Cable Controlled Quick Detach (QD)	Cable Controlled Quick Detach (QD)	Cable Controlled (QD) / XTC Electronic Controls	Cable Controlled
<b>Max Reach, Horizontal (A)</b>	14 feet, 1 inch	16 feet, 5 inches	18 feet, 1 inch	12 feet, 4 inches
<b>Max Reach, Vertical (B)</b>	13 feet, 2 inches	14 feet, 6 inches	16 feet, 1 inch	7 feet, 2 inches
<b>Max Height, Horizontal (C)</b>	13 feet, 5 inches	15 feet, 9 inches	17 feet, 5 inches	10 feet, 6 inches
<b>Max Height, Vertical (D)</b>	13 feet, 9 inches	20 feet, 8 inches	22 feet, 4 inches	16 feet, 3 inches
<b>Max Depth, 45° (E)</b>	5 feet, 4 inches	7 feet, 3 inches	8 feet, 2 inches	4 feet, 6 inches

\* RMB1445-1, RMB1660-1 and RMB1865-1 include weight of oil.



All RMB models offer self-contained, fully independent hydraulic systems with twin pumps for optimum cutting performance.

### Head Selection Tables

	<b>RMB1445-1</b>	<b>RMB1660-1</b>	<b>RMB1865-1</b>	
<b>FLAIL HEAD</b>	<b>Tractor Engine HP/Weight (Min.)</b>	45 HP/4410 lbs.	60 HP/6614 lbs.	65 HP/7716 lbs.
	<b>Rotor / Knife Type</b>	Super Cut/Universal	Super Cut /F91 Competition	or Multi-Cut/ Competition
	<b>Typical Application</b>	Grass, Light Brush	Hedge Cutting, Grass	Hedge Cutting, Grass
	<b>Cutting Capacity</b>	1 inch Diameter	1-1/2 inch Diameter	2 inches Diameter
	<b>Cutting Width</b>	39 inches	47 inches	47 inches
	<b>Weight</b>	309 lbs.	Supercut 520 lbs.	Multi-Cut 712 lbs.
<b>CUTTER BAR</b>	<b>Tractor Engine HP/Weight (Min.)</b>	45 HP/4410 lbs.	60 HP/6614-lbs.	65 HP/7716-lbs.
	<b>Cutter Type</b>	Sickle Bar	Sickle Bar	Sickle Bar
	<b>Cutting Capacity</b>	1-1/4 inch Diameter	1-1/4 inch Diameter	1-1/4 inch
	<b>Cutting Width</b>	59 inches	59 inches	59 inches
	<b>Weight</b>	119 lbs.	143 lbs.	143 lbs.
<b>ROTARY HEAD</b>	<b>Tractor Engine HP/Weight (Min.)</b>	Not Available for use on RMB1445	85 HP/7614-lbs.	85 HP/8716 lbs.
	<b>Typical Application</b>	N/A	Grass/Brush	Grass/Brush
	<b>Cutting Capacity</b>	N/A	4 inches Diameter	4 inches Diameter
	<b>Cutting Width</b>	N/A	60 inches	60 inches
	<b>Weight</b>	N/A	915 lbs.	915 lbs.



\* For rotary head, protective screen material must be installed.  
 \*\* Tractor lift capacity must exceed weight of base unit plus head selection.

SM60

## **SIDE-MOUNTED ROTARY CUTTER**

**Built To Last.**



### **The rotary cutter for those hard to reach places.**

Bush Hog®'s SM60 is your ideal choice for mowing and maintaining rights of way, drainage ditches, lake dams, embankments, and sloping terrain. Available in either 540 or 1,000 RPM models, the SM60 features a 5-foot cutting width, and it attaches to your tractor with a Category II standard or Category II & III quick hitch. Expand your mowing potential with the Bush Hog® SM60 Rotary Cutter.

SM60

## **SIDE-MOUNTED ROTARY CUTTER**

# **The Best Rotary Cutter for Hard-to-Reach Areas**

The SM60 operates on any angle from 85° down to 90° up. Its operation is all hydraulic for higher efficiency, with an anti-cavitation device to protect the cutter's hydraulic system. Maximum reach of the cutter head is over 12 feet from the tractor's center line.

The SM60 is ruggedly built. Deck thickness is 10-gauge, with 10-gauge x 8 inches side bands. The deck's strongback bracing offers extra strength when encountering the shock loads of heavy mowing. The cast iron pump is located to avoid damage during operation.

Round bladeholders allow the cutter to "float" over field obstructions and the blades are 1/2 x 4 inches double-edge design. Blade rotation is clockwise, but may be reversed if needed. The gear-type hydraulic pump is PTO driven, with an oil capacity of 35-gal. (shipped factory filled). For increased stability when operating on extremely sloping terrain, a tailwheel and gauge wheel are available as options.

The Bush Hog SM60 Rotary Cutter is an efficient unit that eliminates the need for costly, specialized mowing equipment and provides outstanding cutting performance, year after year.

Automatic adjusting counter weight is standard equipment. Some competitors offer non-adjusting, optional counter weights.



### **WARNING**

For non-agricultural use, OSHA, ASAE, SAE and ANSI require the use of chain guards or other protective guards at all times. Bush Hog strongly recommends the use of such guards for agricultural use as well, to reduce the risk of property damage, serious bodily injury, or even death from objects thrown out by or from contact with the cutting blades.





Fast attachment to your tractor is achieved with the Cat. II Standard and Cat. II & III Quick Hitch.



Standard equipment includes a convenient parking stand to assist in attaching the SM60 to your tractor. The stand easily pins out of the way during operation.



The optional, adjustable tailwheel provides extra support for the main beam — a real plus when working on rugged terrain.









Standard equipment includes a round blade pan that provides driveline protection by allowing the blades to glide over field obstructions.

SM60

## **SIDE-MOUNTED ROTARY CUTTER**

### **Bush Hog® Features**

-  **All hydraulic** operation
-  **Operates from** 85° down to 90° up
-  **Direct drive** to hydraulic pump
-  **Strongback braced** to help withstand shock loads
-  **Streamlined deck design** to avoid debris and water entrapment
-  **Anti-cavitation device** to protect your cutter's hydraulic system
-  **High blade tip speed** for a cleaner cut in all conditions





## SPECIFICATIONS

Specification	SM60	Specification	SM60
<b>Cutting Width</b>	60 inches	<b>Cutter Head Movement</b>	90° Up to 85° Down
<b>Transport Width</b>	126 inches	<b>Driveline</b>	ASAE Cat. 4, 540 or 1,000 RPM
<b>Type Hitch</b>	Cat. II Standard, Cat. II & III Quick Hitch	<b>Hydraulic Pump Mounting</b>	Machine only, pto drive
<b>Cutting Capacity</b>	1 inch	<b>Hydraulic Oil Capacity</b>	3-gal., factory filled
<b>Minimum Tractor Weight</b>	6,000 lbs.	<b>Hydraulic Capacity</b>	24 GPM /540 RPM; 19.1 GPM /1,000 RPM
<b>Minimum Tractor Lift Capacity</b>	3200 lbs. 24 inches behind lift pins	<b>Overload Protection</b>	Hydraulic relief valve
<b>Deck Thickness</b>	10 gauge	<b>Counterweight</b>	275 lbs., standard
<b>Blade Holder</b>	Round	<b>Weight</b>	1,675 lbs.
<b>Blade Tip Speed</b>	17,300 FPM / 540 RPM; 18,570 FPM / 1,000 RPM	<b>Maximum Extension of Cutter Head</b>	145 inches from tractor center line
<b>Blade RPM</b>	1101	<b>Extension Arm Travel</b>	31-1/4 inches
<b>Blade Rotation</b>	Shipped clockwise, but reversible	<b>Front and Rear Deflectors</b>	Standard equipment
<b>Type Blades</b>	1/2 x 4 inches, double edge	<b>Options</b>	Side gauge wheel, tailwheel for main frame



2501 Griffin Ave.  
Selma, Alabama 36703  
Tel: 800-363-6096  
Fax: 334-874-2701  
[www.bushhog.com](http://www.bushhog.com)

Bush Hog and  (hog icon) are registered trademarks of Alamo Group Inc. Copyright © 2017