Perkins 1300 Series EDi

Models WK to WN

USER'S HANDBOOK

**Six cylinder, turbocharged, diesel engines with an
electronic management system
for industrial and agricultural applications**

Publication TPD. 1352E, Issue 2.

© Proprietary information of Perkins Engines Company Limited, all rights reserved.

The information is correct at the time of print.

Published in May 1998 by Technical Publications,

Perkins Engines Company Limited, Peterborough PE1 5NA, England

This publication is written in
Perkins Approved Clear English

PACE

Contents

1 General information

Introduction	5
How to care for your engine	6
Safety precautions	7
Engine identification	8
Perkins companies	9

2 Engine views

Introduction	11
Location of engine parts	11

3 Operation Instructions

How to start the engine	13
How to start an engine with an ether start system	14
How to stop the engine	14
Adjustment of engine speed range	15
Engine operation at idle speed	15
Running-in	15
Altitude	15

4 Preventive maintenance

Preventive maintenance periods	17
Schedules	18
How to drain the cooling system	19
How to fill the cooling system	20
How to renew the canister of the coolant filter / inhibitor	21
How to check the drive belt	22
How to renew the drive belt	22
Fuel pre-filter	23
How to renew the fuel strainer and the canister of the fuel filter	23
How to eliminate air from the fuel system	24
How to renew the lubricating oil	25

How to renew the canister of the lubricating oil filter	26
Air filter	27
Restriction indicator	27
How to set the valve tip clearances	28

5 Engine fluids

Fuel specification	29
Lubricating oil specification	30
Coolant specification	31

6 Fault diagnosis

Problems and possible causes	33
List of possible causes	34

7 Engine preservation

Introduction	35
Procedure	35

8 Parts and service

POWERPART recommended consumable products	37
---	----

9 General data

Engine	39
--------------	----

1

General information

Introduction

The 1300 Series EDi is a family of engines which have an electronic management system. The engines are designed for industrial and agricultural applications from Perkins Engines Limited, a world leader in the design and manufacture of high-performance diesel engines.

Perkins approved assembly and quality standards, together with the latest technology, have been applied to the manufacture of your engine to give you reliable and economic power.

Note: To ensure that you use the relevant information for your specific engine type, refer to "Engine identification" [on page 8](#).

Danger is indicated in the text by two methods:

Warning! This indicates that there is a possible danger to the person.

Caution: This indicates that there is a possible danger to the engine.

Note: Is used where the information is important, but there is not a danger.

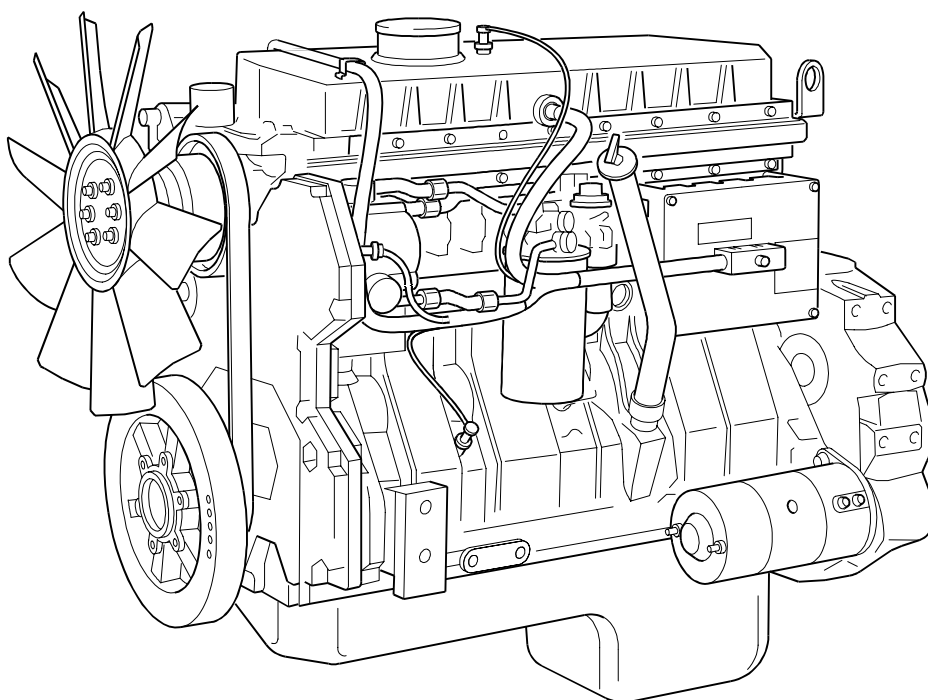

How to care for your engine

This handbook has been written to assist you to maintain and operate your engine correctly.

To obtain the best performance and the longest life from your engine, you must ensure that the maintenance operations are done at the intervals indicated in "Preventive maintenance". If the engine works in a very dusty environment or other adverse conditions, certain maintenance intervals will have to be reduced. Renew the filter canisters and lubricating oil regularly in order to ensure that the inside of your engine remains clean.

Ensure that all adjustments and repairs are done by personnel who have had the correct training. Perkins distributors have this type of personnel available. You can also obtain parts and service from your Perkins distributor. If you do not know the address of your nearest distributor, enquire at one of the Perkins companies listed [on page 9](#).

The terms "left side" and "right side" apply when the engine is seen from the flywheel end.

Warning! *Read the "Safety precautions" and remember them. They are given for your protection and must be applied at all times.*

Safety precautions

These safety precautions are important. You must refer also to the local regulations in the country of use. Some items only apply to specific applications.

- Only use these engines in the type of application for which they have been designed.
- Do not change the specification of the engine.
- Do not smoke when you put fuel in the tank.
- Clean away fuel which has been spilt. Material which has been contaminated by fuel must be moved to a safe place.
- Do not put fuel in the tank while the engine runs (unless it is absolutely necessary).
- Do not clean, add lubricating oil, or adjust the engine while it runs (unless you have had the correct training; even then extreme caution must be used to prevent injury).
- Do not make adjustments that you do not understand.
- Ensure that the engine does not run in a location where it can cause a concentration of toxic emissions.
- Other persons must be kept at a safe distance while the engine or auxiliary equipment is in operation.
- Do not permit loose clothing or long hair near moving parts.
- Keep away from moving parts during engine operation. **Warning!** *Some moving parts cannot be seen clearly while the engine runs.*
- Do not operate the engine if a safety guard has been removed.
- Do not remove the filler cap or any component of the cooling system while the engine is hot and while the coolant is under pressure, because dangerous hot coolant can be discharged.
- Do not use salt water or any other coolant which can cause corrosion in the closed coolant circuit.
- Do not allow sparks or fire near the batteries (especially when the batteries are on charge) because the gases from the electrolyte are highly flammable. The battery fluid is dangerous to the skin and especially to the eyes.
- Disconnect the battery terminals before a repair is made to the electrical system.
- Only one person must control the engine.
- Ensure that the engine is operated only from the control panel or from the operator's position. Discard used lubricating oil in a safe place to prevent contamination.
- Ensure that the control lever of the transmission drive is in the "out-of-drive" position before the engine is started.
- The combustible material of some components of the engine (for example certain seals) can become extremely dangerous if it is burned. Never allow this burnt material to come into contact with the skin or with the eyes.
- Diesel fuel and lubricating oil (especially used lubricating oil) can damage the skin of certain persons. Protect your hands with gloves or a special solution to protect the skin.
- Do not wear clothing which is contaminated by lubricating oil. Do not put material which is contaminated with oil into the pockets of clothing.
- Discard used lubricating oil in accordance with local regulations to prevent contamination.
- Use extreme care if emergency repairs must be made in adverse conditions.
- Always use a safety cage to protect the operator when a component is to be pressure tested in a container of water. Fit safety wires to secure the plugs which seal the hose connections of a component which is to be pressure tested.
- Do not allow compressed air to contact your skin. If compressed air enters your skin, obtain medical help immediately.
- Turbochargers operate at high speed and at high temperatures. Keep fingers, tools and debris away from the inlet and outlet ports of the turbocharger and prevent contact with hot surfaces.
- The fuel injector units of this engine are controlled electronically by a pulse of 110 volts.
- The fuel injector units are actuated by high-pressure engine lubricating oil. Do not remove any component of the high-pressure system while the engine oil is under pressure, because dangerous oil can be discharged.
- Fit only genuine Perkins parts.

Engine identification

The 1300 Series EDi engines consist of a range of six cylinder in-line engines which are turbocharged or turbocharged/intercooled. The engines have an electronic management system.

In this handbook, the different engine types are indicated by their code letters, which are the first two letters of the engine number as indicated below:

Code letters	Capacity		Aspiration system
	Litre	in ³	
WK	7,6	466	Turbocharged
WL	7,6	466	Turbocharged / intercooled
WM	8,6	531	Turbocharged
WN	8,6	531	Turbocharged / intercooled

The engine number is stamped on the left side of the cylinder block (A1), behind the high pressure pump.

An example of an engine number is WL1296N123456.

The components of the engine number are as follows:

WL1296N123456

WL	Type code letters
1296	Build list number
N	Built in the USA
123456	Engine serial number

If you need parts, service or information for your engine, you must give the complete engine number to your Perkins distributor.

Perkins companies

Australia

Perkins Engines Australia Pty. Ltd,
Suite 2, 364 Main Street,
Mornington 3931, Victoria, Australia.
Telephone: 0061 (0) 597 51877
Telex: Perkoil AA30816
Fax: 0061 (0) 597 1305

China

Perkins Engines (Tianjin) Ltd,
Jinwei Road,
Beichen District,
Tianjin,
300402
China
Telephone: (86) (22) 2699 2288
Fax: (86) (22) 2699 3784

France

Moteurs Perkins S.A.,
"Parc des reflets",
165 Avenue du Bois de la Pie,
95700 Roissy Charles de Gaulle, France.
Telephone: 0033 (01) 49-90-7171
Fax: 0033 (01) 49-90-7190

Germany

Perkins Motoren GmbH,
Saalaeckerstrasse 4,
63801 Kleinostheim,
Germany.
Telephone: 0049 6027 5010
Fax: 0049 6027 501124

Italy

Motori Perkins S.p.A.,
Via Socrate 8,
22070 Casnate con Bernate (Como), Italy.
Telephone: 0039 (0) 31 564633/564625
Fax: 0039 (0) 31 565480/564145/396001

Japan

Perkins Engines (Japan) K.K.,
Reinanzaka Building, 5th Floor,
14-2 Akasaka, 1-chome, Minato-ku,
Tokyo 107, Japan.
Telephone: 0081 (0) 3 586 7377
Telex: Perkoil J2424823
Fax: 0081 (0) 3 582 1596

Korea

Perkins Engines (Korea)
Textile Center 12F
Daechi 3 dong 944-31
Kangnam-Ku
Seoul, 135-283
Korea
Telephone: (822) 528 3377
Fax: (822) 528 3378

United Kingdom

Perkins Engines Company Ltd,
Eastfield, Peterborough PE1 5NA,
England.
Telephone: 0044 (0) 1733 583000
Telex: 32501 Perken G
Fax: 0044 (0) 1733 582240

United States of America

Perkins Engines - North America
12025 Tech Center Drive
Livonia
Michigan 48150
USA
Telephone: 001 313 266 5427
Fax: 001 313 266 2700

Perkins Engines Latin America Inc,
Suite 620,
999, Ponce de Leon Boulevard,
Coral Gables,
Florida 33134, U.S.A.
Telephone: 001 305 442 7413
Telex: 32501 Perken G
Fax: 001 305 442 7419

Singapore

Perkins Engines (Far East) Pte Ltd,
39 Tuas Avenue 13
Singapore 638999
Telephone: (65) 861 1318
Fax: (65) 861 6252

In addition to the above companies, there are Perkins distributors in most countries. Perkins Engines Company Limited., Peterborough or one of the above companies can provide details.

2

Engine views

Introduction

Perkins engines are built for specific applications and the views which follow do not necessarily match your engine specification.

Location of engine parts

Front and left side view (A)

- | | |
|---|---|
| 1 Fan | 8 Sensor for the inlet manifold air temperature |
| 2 Wiring harness to the sensor for injection control pressure | 9 electrical connector for the injector units |
| 3 Sensor for engine oil temperature | 10 Supply manifold |
| 4 Camshaft position sensor | 11 Lubricating oil filler and dipstick |
| 5 Sensor for engine oil pressure | 12 Engine control module |
| 6 Crankshaft damper | 13 Fuel strainer |
| 7 Sump for the engine lubricating oil | 14 Canister for the fuel filter |
| | 15 Starter motor |

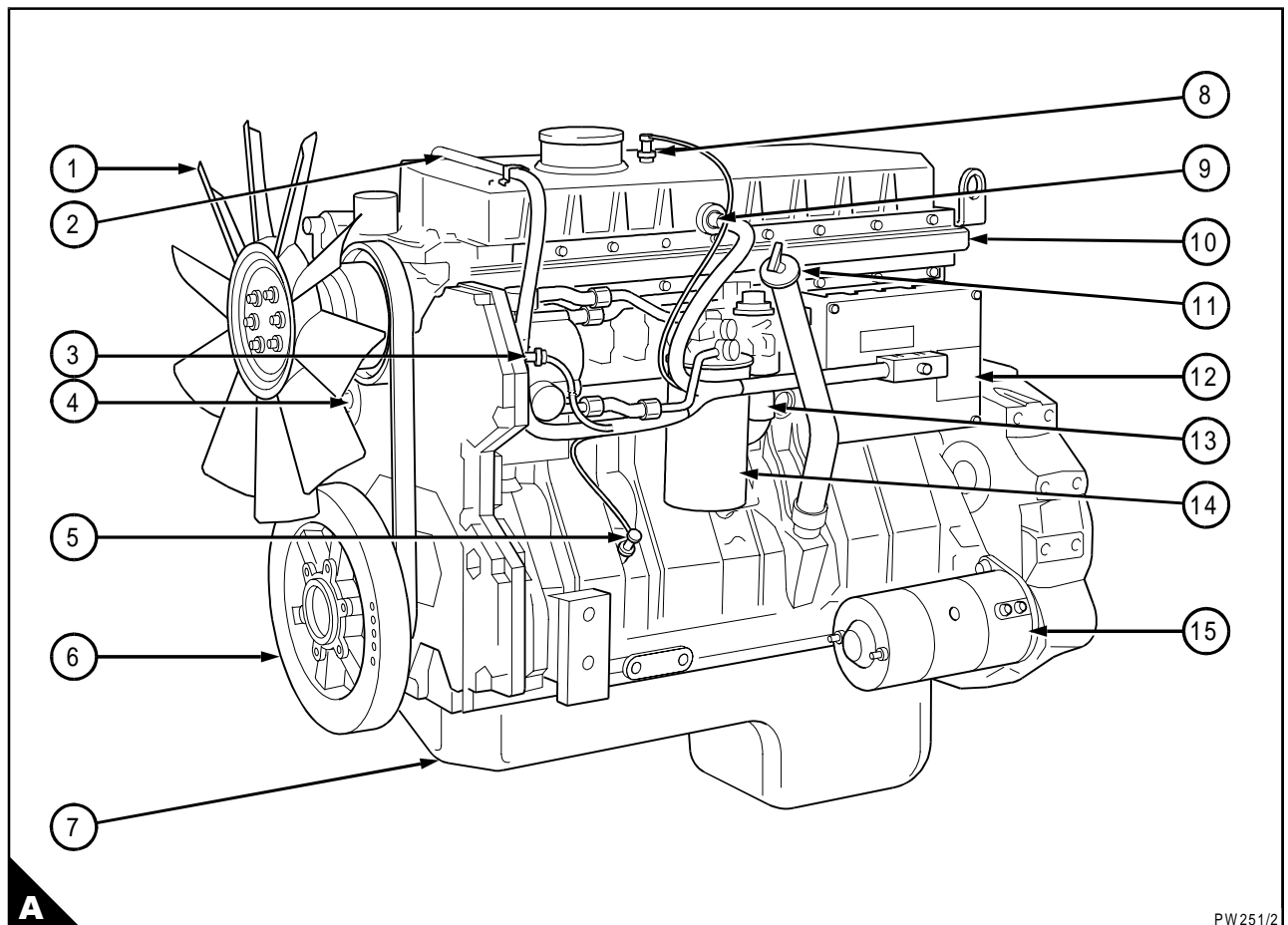

Rear and right side view (A)

- | | |
|--|--|
| 16 Rear lift bracket | 24 Front lift bracket |
| 17 Engine breather pipe | 25 Coolant temperature sensor |
| 18 Turbocharger | 26 Alternator |
| 19 Wastegate | 27 Tensioner for the drive belt |
| 20 Flywheel | 28 Canister for the coolant filter / inhibitor |
| 21 Flywheel housing | 29 Coolant pump |
| 22 Canister for the lubricating oil filter | 30 Coolant inlet connection |
| 23 Air inlet connection | 31 Lubricating oil cooler |

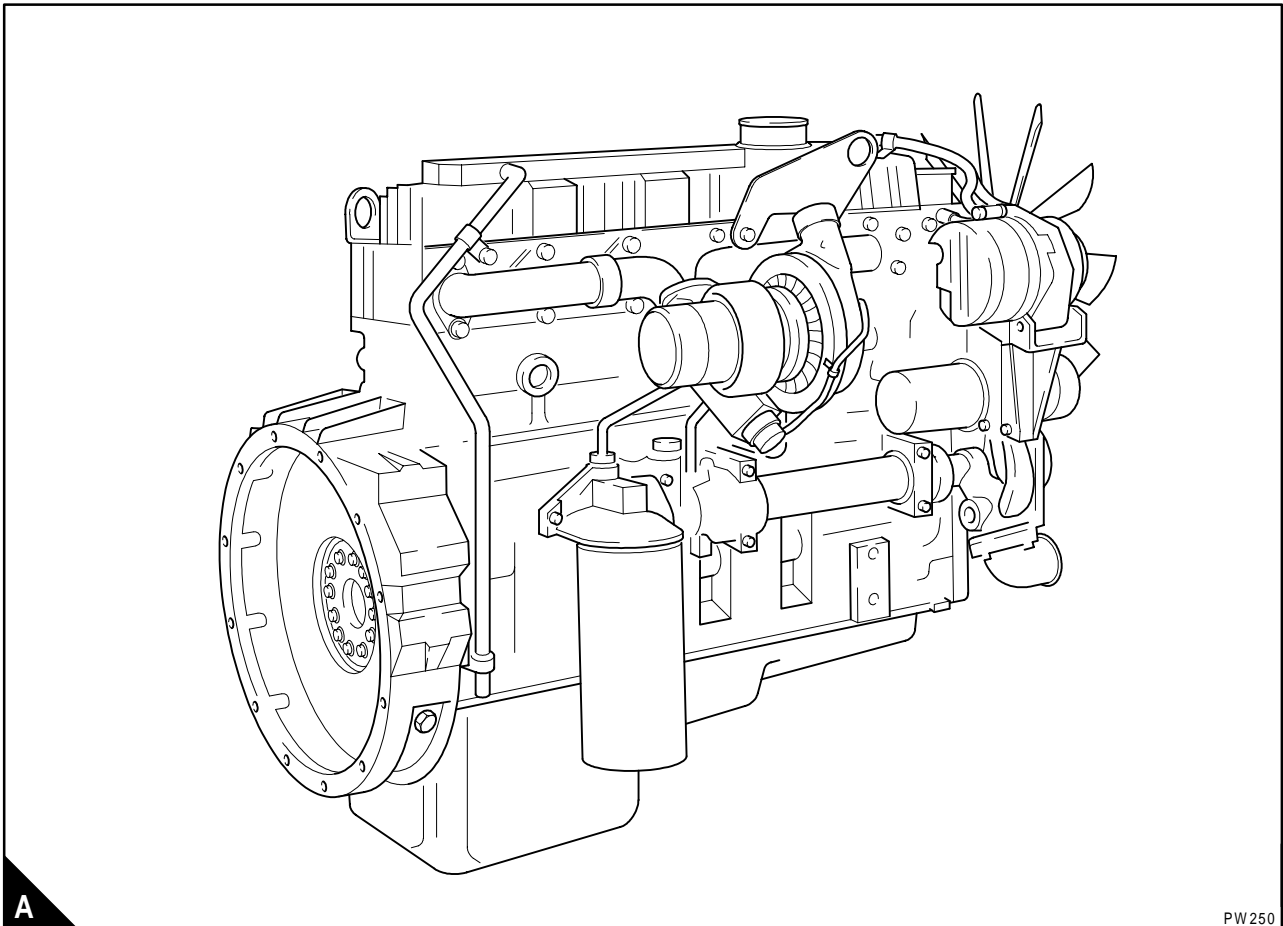

3

Operation Instructions

How to start the engine

Temperature of 15°C (60°F) to -20°C (-4°F)

Several factors affect engine start, for example:

- The power of the batteries
- The performance of the starter motor
- The viscosity of the lubricating oil
- The installation of a cold start system.

The engine will start without a cold starting aid at temperatures as low as -20°C (-4°F). In conditions where the temperature is lower than this, an ether start system may be necessary.

Before the engine is started the operator should understand fully the reason for the controls and their use.

Before the engine is started:

- Check that there is sufficient coolant and, if necessary, add the correct coolant, see section 4.
- Check that there is sufficient lubricating oil in the sump and, if necessary, add lubricating oil. See section 4 of this handbook. Ensure that the lubricating oil is of the correct grade for the ambient conditions.
- Fill the fuel tank with fuel of the correct specification, see section 5.
- Check the air filter and its connections.
- Ensure that all of the electrical connections are tight.

Note:

- See section 5 of this handbook for the correct engine fluids.
- The procedures to start the engine may vary according to the application. If possible, consult the User's Handbook for the application.

1 Apply the hand brake, if the application is fitted with one. Ensure that the transmission is in the out-of-drive position. Ensure that the engine speed control is in the minimum speed position.

2 Turn the start key to the "ON" position.

Note: Do not operate the engine speed control during engine start, the management system controls the supply of fuel, and it will ignore signals from the speed control until the engine starts.

3 Turn the start key further to engage the starter motor. If the application has a start button, press and hold the button.

4 Release the start key (or the button) as soon as the engine starts. The start key will return to the "ON" position.

Caution: *If the engine does not start within 30 seconds, release the start key and wait two to three minutes to allow the starter motor to cool. If after three tries the engine does not start, turn the key to the "OFF" position.*

5 Locate and correct the problem. Always ensure that the engine and starter motor are stationary before the starter motor is engaged again.

When the engine starts, check that the lubricating oil pressure exceeds 138 kPa (20 lbs/in²) 1,4 kgf/cm² within the first 10 seconds, see section 9 for the correct lubricating oil pressure. If a gauge is not fitted, check that the warning light for low oil pressure is extinguished. If this does not occur, stop the engine and find and correct the fault. Allow the engine to warm at approximately 1000 rev/min for three to five minutes before load is applied.

How to start an engine with an ether start system

Ambient temperature below -20°C (-4°F)

Caution: Ether is very flammable and is toxic. Apply the safety precautions on the container for the use and storage of ether and for the disposal of empty containers.

1 Apply the hand brake. Ensure that the transmission is in the out-of-drive position. Check the ether container to ensure that a supply of ether is available under pressure.

2 Ensure that the engine speed control is still in the idle position.

Note: Do not operate the engine speed control during engine start, the management system controls fuel supply and it will ignore signals from the speed control until the engine starts.

3 Turn the start key to the "ON" position.

4 Turn the start key further to engage the starter motor. If the application has a start button, press and hold the button to engage the starter motor, and at the same time press the ether injection button. Allow one to two seconds for the ether injection system to fill then release the injection button to release a measured amount of ether into the engine.

Caution: Release of ether into the cylinders before the starter motor is engaged may cause damage to the pistons and piston rings.

5 Release the start key (or the start button, if one is fitted) as soon as the engine starts. The start key will return to the "ON" position.

Caution: If the engine does not start within 30 seconds, release the start key and wait two to three minutes to allow the starter motor to cool. If after three tries the engine does not start, turn the key to the "OFF" position and locate and correct the problem. Always ensure that the engine and starter motor are stationary before the starter motor is engaged again.

Note: In extremely cold conditions, it is permissible to inject further ether into the engine if the engine runs roughly after the initial start.

Caution: Do not inject ether into a warm engine.

6 When the engine starts check that the lubricating oil pressure exceeds 138 kPa (20 lbs/in²) 1,4 kgf/cm² within the first 25 seconds, see section 9 for the correct lubricating oil pressure. If a gauge is not fitted, check that the warning light for low oil pressure is extinguished. If this does not occur, stop the engine.

Find and correct the fault. Allow the engine to warm at approximately 1000 rev/min for three to five minutes before load is applied.

How to stop the engine

Turn the engine start key to the "OFF" position.

It is recommended that the engine is operated at idle speed for three to five minutes before the engine is stopped. This will allow the lubricating oil and the coolant to carry the heat away from large ferrous components.

Adjustment of engine speed range

The idle or maximum speed settings cannot be changed by the engine operator.

Engine operation at idle speed

Do not operate the engine for long periods at idle speed as this could have an adverse affect on the engine performance or damage the engine.

Running-in

A gradual running-in of a new engine is not necessary. Prolonged operation at light loads during the early life of the engine is not recommended.

Maximum load can be applied to a new engine as soon as the engine is put into service and the coolant temperature has reached a minimum of 76°C (170° F).

- Do not operate the engine at high speeds without a load.
- Do not overload the engine.

Altitude

The engine management system will automatically compensate for altitude.

4

Preventive maintenance

Preventive maintenance periods

These preventive maintenance periods apply to average conditions of operation. Check the periods given by the manufacturer of the equipment in which the engine is installed. Use the periods which are shortest . When the operation of the engine must conform to the local regulations these periods and procedures may need to be adapted to ensure correct operation of the engine.

It is good preventive maintenance to check for leakage and loose fasteners at each service.

These maintenance periods apply only to engines that are operated with fuel and lubricating oil which conform to the specifications given in this handbook.

4

Schedules

The schedules which follow must be applied at the interval (hours or months) which occur first..

- A** Every day or every 8 hours **D** Every 3600 hours or 24 months **G** Annually
B Every 450 hours or 6 months **E** Every 5000 hours
C Every 900 hours or 12 months **F** Every 6700 to 7500 hours

A	B	C	D	E	F	G	Operation
●							Ensure that the coolant is at the correct level
●							Check the intercooler and the coolant radiator for debris
	●						Check, and adjust if necessary, the antifreeze mixture (2)
	●						Test the level of coolant conditioner, and adjust if necessary (2)
	●						Check the condition of the drive belt
			●				Renew the coolant (4)
						●	Renew the canister of the coolant filter (3)
						●	Inspect the thermostat (2)
●							Drain water from the fuel pre-filter (1)
		●					Renew the canister of the fuel filter and renew the fuel strainer
●							Check the amount of lubricating oil in the sump
●							Check the lubricating oil pressure at the gauge (1)
	●						Renew the engine lubricating oil (5)
	●						Renew the canister of the lubricating oil filter
	●						Clean or renew the air filter element (or earlier if in extremely dusty conditions)
				●			Ensure that the valve tip clearances of the engine are checked and, if necessary, adjusted (2)
					●		Ensure that the turbocharger impeller and the turbocharger compressor casing are cleaned (2)
					●		Ensure that the alternator, the starter motor, and the turbocharger are checked
						●	Inspect the electrical system (2)

- (1) If one is fitted.
(2) By a person who has had the correct training.
(3) Also if the coolant system has been drained.
(4) The system should be flushed and a new canister fitted.
(5) The oil change interval will change with the sulphur content of the fuel (see the table below and the Fuel Specification in section 5). The interval to change the canister of the lubricating oil filter is not affected.
(6) Use the **POWERPART test-kit**, part number 26550004.

Fuel sulphur content (%)	Oil change interval
<0.5	Normal
0.5 to 1.0	75% of normal
>1.0	50% of normal

How to drain the cooling system

Warning! Do not drain the coolant while the engine is still hot and the system is under pressure because dangerous hot coolant can be discharged.

- 1 Ensure that the machine is on level ground.
- 2 Remove the filler cap of the cooling system.
- 3 Remove the drain plug (A1) from the side of the cylinder block (below the rear of the high-pressure pump) and the drain plug (B1) from the lubricating oil cooler in order to drain the engine. Ensure that the drain holes are not restricted.
- 4 Open the tap or remove the drain plug at the bottom of the radiator in order to drain the radiator. If the radiator does not have a tap or drain plug, disconnect the hose at the bottom of the radiator.
- 5 Flush the system with POWERPART Easy Flush.
- 6 Fit the drain plugs and the filler cap. Close the radiator tap or connect the radiator hose.
- 7 Renew the canister, part number 26550001, of the coolant filter.

Caution: The canister contains a corrosion inhibitor which is circulated around the cooling system as the coolant passes through the canister. It is important that only the genuine correct Perkins canister is used.

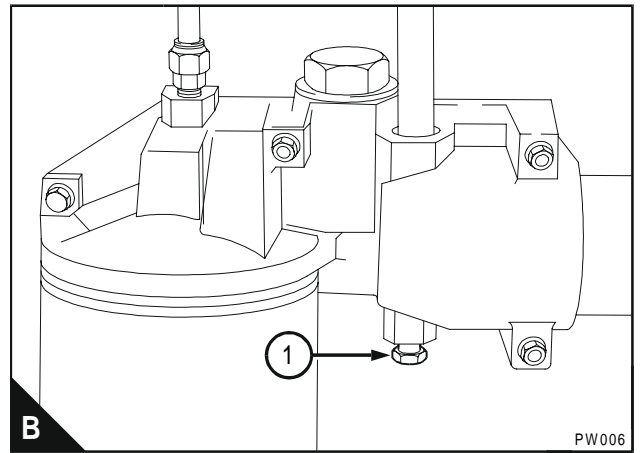
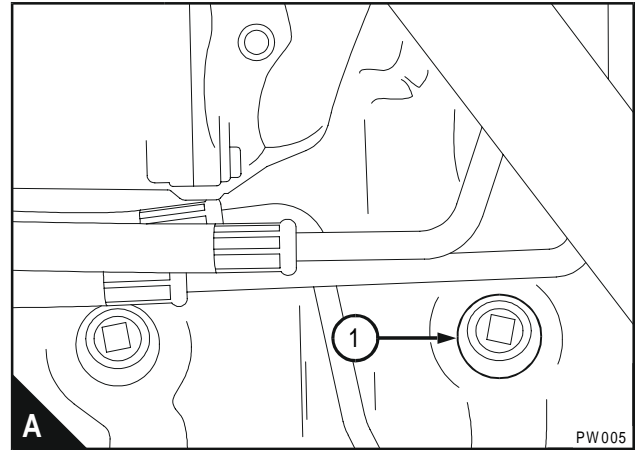

How to fill the cooling system

Caution: See "Coolant specification" in section 5 for details of the correct coolant to be used in the cooling system. If coolant is added to the system during service, it must consist of the same original mixture as used to fill the system. The engine must be allowed to cool before coolant is added.

Warning! Do not remove the filler cap while the engine is still hot and the system is under pressure because dangerous hot coolant can be discharged.

- 1 Remove the filler cap of the cooling system.
- 2 The cooling system must be filled very slowly in order to eliminate air. Fill the cooling system until coolant reaches the bottom of the filler tube. Fit the filler cap.
- 3 Start the engine. Allow the engine to operate at a fast idle until the engine reaches its normal temperature of operation. Stop the engine and allow it to cool.

Remove carefully the filler cap and add coolant until the level of the coolant reaches the filler tube. Fit the filler cap.

How to renew the canister of the coolant filter / inhibitor

Warning! Do not remove the canister while the engine is still hot and under pressure because dangerous hot fluid can be discharged.

Caution: The canister contains a corrosion inhibitor which is circulated around the cooling system as the coolant passes through the canister. It is important that only the genuine correct Perkins canister is used.

1 When the engine has cooled, remove the radiator filler cap to release the system pressure.

Note: When the system pressure is released, valves will close in the filter canister and in the housing for the canister. This will prevent the loss of coolant when the filter is removed.

2 Thoroughly clean the outside surfaces of the coolant filter assembly.

3 Use a strap wrench or similar tool to loosen the filter canister and remove the canister. Valves in the filter head will prevent the loss of coolant when the canister is removed.

4 Ensure that the threaded adaptor (A2) is secure in the filter head and that the inside of the head is clean.

5 Lubricate lightly the seal (A1) on top of the new canister with clean engine coolant. Fit the new canister to the filter head and tighten, by hand only. Do not overtighten the canister.

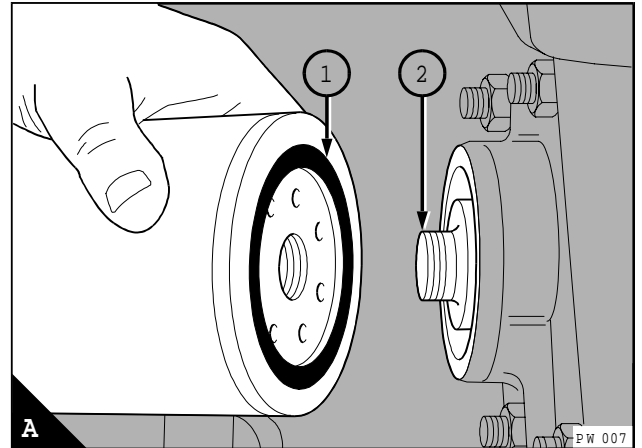

How to check the drive belt

There is no need to check the tension of the belt as the tension is set automatically. The condition of the belt should be checked. The belt should be renewed if there are cracks in the belt or if the belt is contaminated by oil or grease.

How to renew the drive belt

1 Fit a square headed lever (A3) into the 12,7 mm (0.5 in) hole (A2) in the tensioner assembly (A1). Operate the lever to release the tension from the belt (A4) and remove the belt. The tensioner will return to its original position by spring pressure. Remove the lever.

2 With the lever in the tensioner, pull the tensioner outwards. Put the new belt in position around all of the pulleys. Ensure that the tensioner pulley is on the outside of the belt. Allow the tensioner to return and tension the belt. Remove the lever.

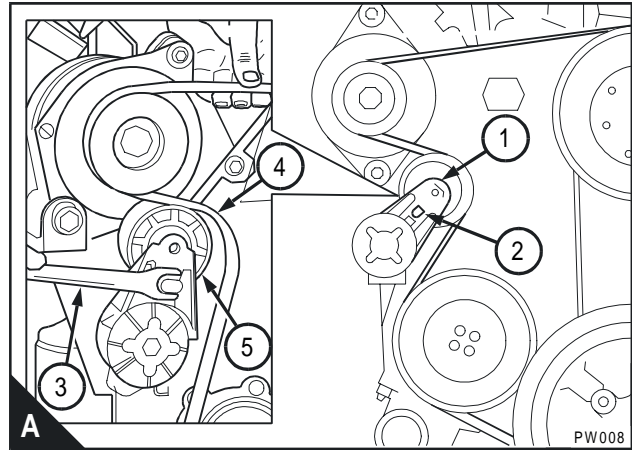

Fuel pre-filter

This will normally be fitted between the fuel tank and the engine. Check the filter bowl for water at regular intervals and drain as necessary.

How to renew the fuel strainer and the canister of the fuel filter

The fuel filter assembly has a fuel strainer to remove larger particles from the fuel and a filter canister to remove the smaller particles. The fuel strainer can be cleaned, but the fuel filter must be renewed.

- 1 Thoroughly clean the outside surfaces of the fuel filter assembly.
 - 2 Use a strap wrench or similar tool to loosen the filter canister, and remove the canister.
 - 3 Use a 29 mm (1.1/8 in) socket spanner to remove the plastic cover (A5) from the fuel strainer. Remove the strainer (A3) and the 'O' ring (A4) from the the cover.
 - 4 Fit a new strainer and a new 'O' ring to the cover and fit the cover to the filter head.
- Caution:** Ensure that the open end of the new strainer is toward the filter head.
- 5 Ensure that the threaded adaptor (A1) is secure in the filter head and that the inside of the head is clean. Lubricate lightly the seal (A2) of the new canister with clean diesel fuel. Fit the new canister to the filter head and tighten the canister by hand until the seal contacts the filter head. Tighten the canister a further 1/2 turn by hand only. Do not use a strap wrench.
 - 6 Eliminate the air from the fuel filter, [see page 24](#).

Caution: It is important that only the genuine Perkins parts are used. The use of wrong parts could damage the fuel injector units.

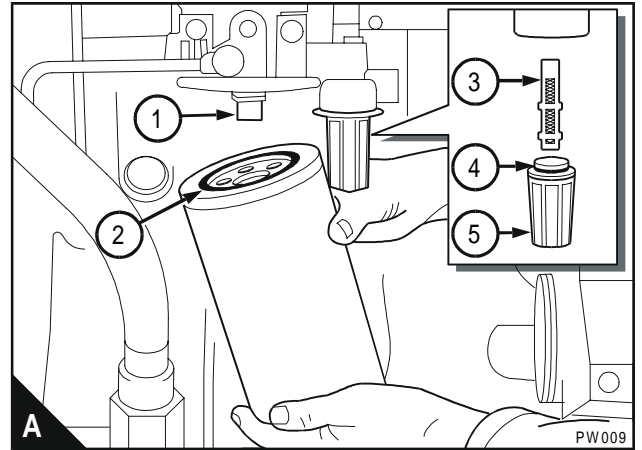

How to eliminate air from the fuel system

If air enters the fuel system, it must be eliminated before the engine can be started.

Air can enter the system if:

- The fuel tank is drained during normal operation.
- The low-pressure fuel pipes are disconnected.
- A part of the low-pressure fuel system leaks during engine operation.

In order to eliminate air from the fuel system, proceed as follows:

- 1** Loosen the vent plug (A1) on the top of the fuel filter head.
- 2** Operate the plunger of the fuel priming pump (A2) until fuel, free from air, comes from the filter vent point. Tighten the vent plug.
- 3** Turn the start key to the "ON" position.
- 4** Operate the starter motor for intervals of 15 seconds until the engine starts. If the engine runs correctly for a short time and then stops or runs roughly, check for air in the fuel system. If there is air in the fuel system, there is probably a leakage in the low pressure system. Turn the start key to the "OFF" position to stop the engine. Rectify the leakage and repeat the procedure.

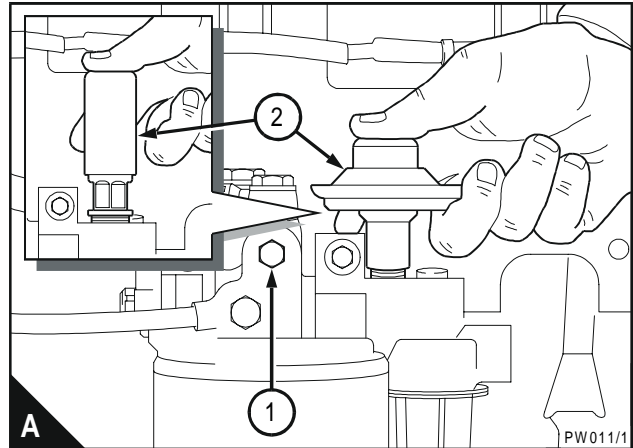

How to renew the lubricating oil

- 1 Operate the engine until it is warm.
- 2 Stop the engine.
- 3 Put a container with a capacity of approximately 30 litres (6.5 UK gallons) 32 US quarts beneath the sump. Remove the sump drain plug (A1) and its washer and drain the lubricating oil from the sump. Ensure that the 'O' ring is not damaged. Fit the drain plug and its washer and tighten the plug to 68 Nm (50 lbf ft) 6,9 kgf m.
- 4 Turn the handle on top of the filler cap (B2) counter-clockwise to release the filler cap and dipstick assembly from the filler tube.
- 5 Fill the sump to the "FULL" mark on the dipstick (B1) with new and clean lubricating oil of an approved grade, [see page 30](#).
- 6 Fit the dipstick and filler cap assembly and turn the handle on the cap clockwise to tighten the filler cap in the filler tube.
- 7 Remove the container of used lubricating oil from beneath the engine.

Warning! Discard the used lubricating oil in a safe place and in accordance with local regulations.

- 8 Start the engine and check for lubricating oil leakage. Stop the engine. After 15 minutes check the oil level on the dipstick and, if necessary, put more lubricating oil into the sump.

Caution: Do not fill the sump past the "FULL" mark on the dipstick.

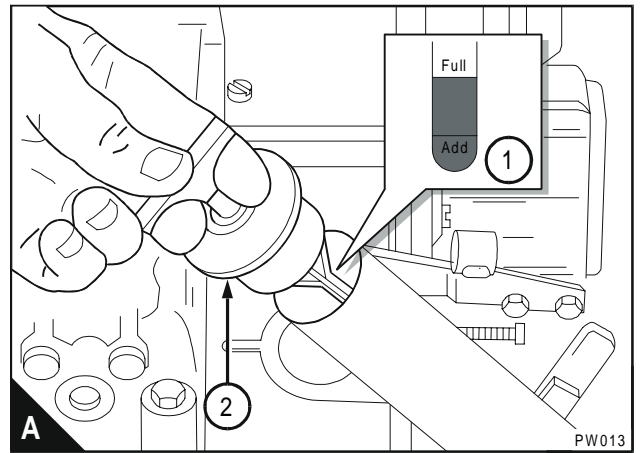
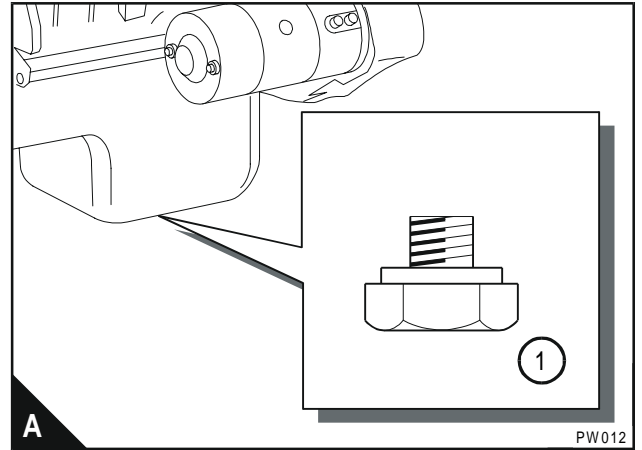

How to renew the canister of the lubricating oil filter

- 1 Put a tray under the filter to retain spilt lubricating oil.
- 2 Clean thoroughly the outside surfaces of the filter assembly.
- 3 Use a strap wrench or similar tool to loosen the filter canister. Remove and discard the canister. Ensure that the adaptor (A1) is secure in the filter head.

Warning! Discard the used canister and lubricating oil in a safe place and in accordance with local regulations.

- 4 Clean inside the filter head
- 5 Lubricate the seal (A2) on top of the canister with clean engine lubricating oil.
- 6 Fill the new filter canister with clean engine lubricating oil. Fit the new canister and tighten by hand until the seal contacts the filter head. Tighten the canister a further 1/2 to 3/4 of a turn by hand only. Do not use a strap wrench.
- 7 Ensure that there is lubricating oil in the sump.
- 8 Turn the start key to the "ON" position and start the engine.

Note: The engine will not start and operate until oil pressure is obtained. Oil pressure is indicated when the warning light is extinguished or by a reading on the gauge.

When the engine starts check for leakage from the filter. Stop the engine. After 15 minutes check the oil level on the dipstick and, if necessary, put more lubricating oil of an approved grade into the sump.

Caution: Do not fill the sump past the "FULL" mark on the dipstick.

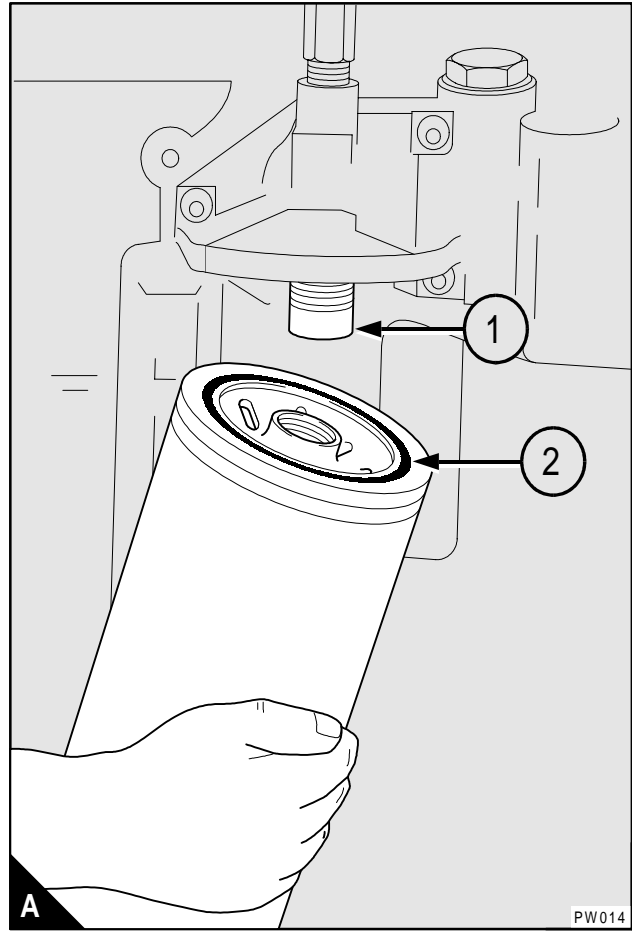

Air filter

Environmental conditions have an important effect on the frequency at which the air filter needs service.

The filter element must be cleaned or renewed according to the manufacturer's recommendations.

Restriction indicator

The restriction indicator for these engines must work at a pressure difference of 635 mm (25 in) of water gauge. It is fitted on the air filter outlet or between the air filter and the induction manifold.

The restriction indicator should be tested according to the manufacturer's recommendations.

How to set the valve tip clearances

The valve tip clearance is checked with feeler gauges between the top of the valve stem and the rocker lever (B), with the engine cold. The correct clearance for the inlet valves and the exhaust valves is 0,64 mm (0.025 in). The valve positions are shown at (A).

The arrangement of the valves for each cylinder in sequence is inlet valve then exhaust valve.

Note: Number 1 cylinder is at the front of the engine.

- 1 Disconnect the air inlet pipe at the rocker cover/induction manifold.
- 2 Release the 13 cap screws which retain the rocker cover and remove the cover.
- 3 Turn the crankshaft in the normal direction of rotation until valve 11 (A) has just opened and valve 12 has not closed fully. Check/adjust the clearances of valves 1 and 2.
- 4 Set valves 3 and 4 as indicated above then check/adjust the clearances of valves 9 and 10.
- 5 Set valves 7 and 8 then check/adjust the clearances of valves 5 and 6.
- 6 Set valves 1 and 2 then check/adjust the clearances of valves 11 and 12.
- 7 Set valves 9 and 10 then check/adjust the clearances of valves 3 and 4.
- 8 Set valves 5 and 6 then check/adjust the clearances of valves 7 and 8.
- 9 If necessary, put a new rocker cover/induction manifold gasket in position on the cylinder head. Align carefully the cover and the gasket. Fit the cap screws which retain the rocker cover and tighten them to 17 Nm (13 lbf ft) 1,7 kgf m.
- 10 Connect the air inlet pipe to the rocker cover.

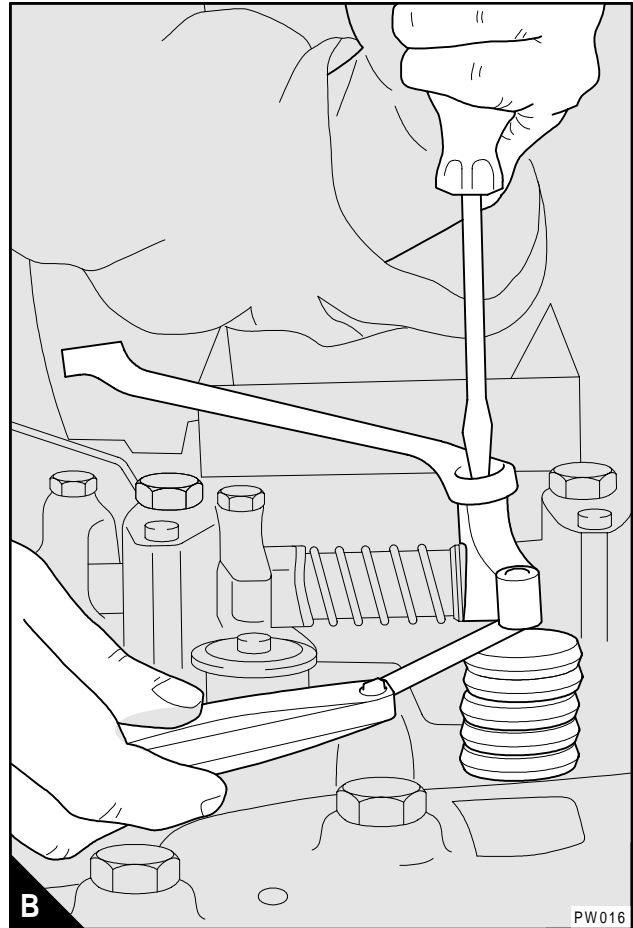

B

PW016

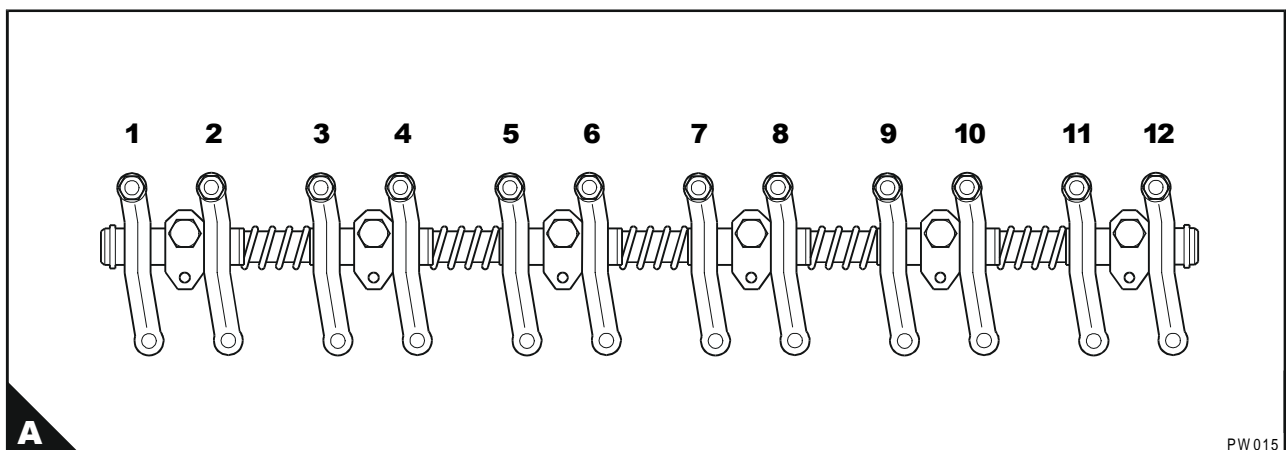

A

PW015

5

Engine fluids

Fuel specification

To get the correct power and performance from your engine, use good quality fuel. The recommended fuel specification for Perkins engines is indicated below:

Cetane number	. 50 minimum
Viscosity 2.0/4.5 centistokes at 40°C
Density 0,835/0,855 kg/litre
Sulphur 0.2% of mass, maximum
Distillation 85% at 350°C

JP5 and JP8 can be used, but they can affect engine performance and wear in the fuel injector units could increase. It is recommended that you consult the Technical Service Department of Perkins International Limited at Peterborough if aviation kerosene fuel is to be used.

Aviation kerosene fuels are more flammable than diesel fuel and need careful storage and careful management.

Cetane number indicates ignition performance. A fuel with a low cetane number can cause cold start problems and affect combustion.

Viscosity is the resistance to flow and engine performance can be affected if it is outside the limits.

Density: A lower density reduces engine power, a higher density increases engine power and exhaust smoke.

Sulphur: A high sulphur content (not normally found in Europe, North America or Australasia) can cause engine wear. Where only high sulphur fuels are available, it is necessary to use a highly alkaline lubricating oil in the engine or to renew the lubricating oil more frequently, [see page 18](#).

Distillation: This is an indication of the mixture of different hydrocarbons in the fuel. A high ratio of light-weight hydrocarbons can affect the combustion characteristics.

Low temperature fuels

Special winter fuels may be available for engine operation at temperatures below 0°C. These fuels have a lower viscosity and also limit the wax formation in the fuel at low temperatures. If wax formation occurs, this could stop the fuel flow through the filter.

If you need advice on adjustments to an engine setting or to the lubricating oil change periods which may be necessary because of the standard of the available fuel, consult the Technical Service Department of Perkins International Limited at Peterborough or your nearest Perkins Distributor.

Aviation kerosene fuels

Caution: Do not use aviation kerosene fuel JP4.

Lubricating oil specification

Lubricating oil to the recommended specification API CG-4 or ACEA E3 must always be used in countries where it is available for purchase. In countries where it is not available, API CF4 or ACEA E2 must be used.

Caution: *The type of lubricating oil to be used may be affected by the quality of the fuel which is available. For further details see "Fuel specification" on page 29.*

Always ensure that the correct viscosity grade of lubricating oil is used for the ambient temperature range in which the engine will run as shown in the chart (A).

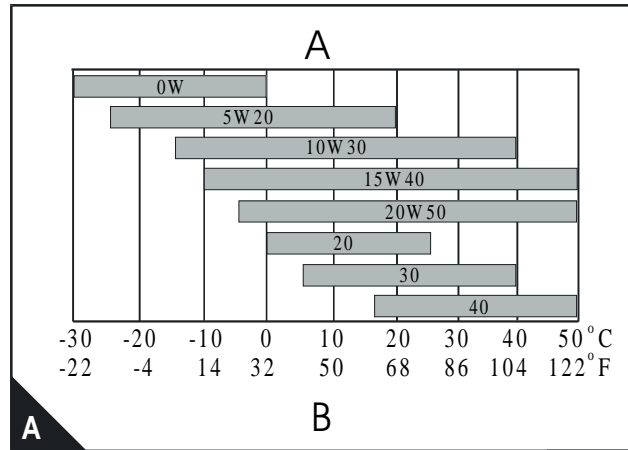

Viscosity chart

A = Recommended viscosity

B = Ambient temperature

Coolant specification

The quality of the coolant which is used can have a great effect on the efficiency and life of the cooling system. The recommendations indicated below can help to maintain a good cooling system and to protect it against frost and/or corrosion.

If the correct procedures are not used, Perkins cannot be held responsible for frost or corrosion damage.

- 1 If it is possible, use clean soft water in the coolant.
- 2 If an antifreeze mixture, other than Perkins POWERPART, is used to prevent frost damage, it must have an ethanediol base (ethylene glycol) with a corrosion inhibitor. It is recommended that the corrosion inhibitor is of the sodium nitrite/sodium molybdate type. The antifreeze mixture must be an efficient coolant at all ambient temperatures and it must provide protection against corrosion. It must also have a specification at least as good as the requirements of either BS6580 or MOD AL39.

Perkins POWERPART antifreeze exceeds the requirements of the above standard.

The quality of the antifreeze coolant must be checked at least once a year, for example, at the beginning of the cold period. The coolant must be renewed every two years.

The antifreeze mixture must consist of equal quantities of antifreeze and water. Concentrations of more than 50% of antifreeze must not be used because these can affect adversely the performance of the coolant.

- 3 When frost protection is not necessary, it is still an advantage to use an approved antifreeze mixture because this gives a protection against corrosion and also raises the boiling point of the coolant. If an approved antifreeze mixture is not available, add a correct mixture of corrosion inhibitor to the water.

All 1300 Series EDi engines are supplied with a coolant filter / conditioner canister. Renew the coolant and the filter / conditioner canister in accordance with the maintenance schedules [on page 18](#). Test the level of coolant conditioner, and adjust if necessary in accordance with the maintenance schedules [on page 18](#).

6

Fault diagnosis

Problems and possible causes

Problem	Possible causes	
	Checks by the user	Checks by the workshop personnel
The starter motor turns the engine too slowly	1, 2, 3, 4	
The engine does not start	5, 6, 7, 8, 9, 10, 12, 13, 14, 15, 17	37, 38, 42, 43, 44, 66, 67, 68, 69
The engine is difficult to start	5, 7, 8, 9, 10, 11, 12, 13, 14, 15, 16, 17, 19	37, 38, 40, 42, 43, 44, 66
Not enough power	8, 9, 10, 11, 12, 13, 16, 8, 9, 20, 21	37, 38, 39, 42, 43, 44, 61, 63, 64, 66, 68, 69
Misfire	8, 9, 10, 12, 13, 15, 20, 22	37, 38, 39, 40, 43, 66, 69
High fuel consumption	11, 13, 15, 17, 18, 19, 23, 22	37, 38, 39, 40, 42, 43, 44, 63, 66
Black exhaust smoke	11, 13, 15, 17, 19, 21, 22	37, 38, 39, 40, 42, 43, 44, 61, 63, 66
Blue or white exhaust smoke	4, 15, 21, 23	37, 38, 39, 42, 43, 44, 45, 52, 58, 62, 66, 68
The pressure of the low pressure lubricating oil system is too low	4, 24, 25, 26	46, 47, 48, 50, 51, 59,
The engine knocks	9, 13, 15, 17, 20, 22, 23	37, 40, 42, 44, 46, 52, 53, 60, 66, 68
The engine runs erratically	8, 9, 10, 11, 12, 13, 15, 16, 18, 20, 22, 23	38, 40, 44, 52, 60, 66, 68, 69
Vibration	13, 18, 20, 27, 28	38, 39, 40, 44, 52, 54, 66, 68, 69
The pressure of the low pressure lubricating oil system is too high	4, 25	49
The engine oil temperature is too high	11, 13, 15, 19, 27, 29, 30, 32, 65	37, 39, 52, 55, 56, 57, 64, 69
Crankcase pressure	31, 33	39, 42, 44, 45, 52
Bad compression	11, 22	37, 39, 40, 42, 43, 44, 45, 53, 60
The engine starts and stops	10, 11, 12	66, 68, 69
The pressure of the high pressure lubricating oil system is too low	4, 24, 25, 26	66, 68, 69

List of possible causes

- 1 Battery capacity low.
- 2 Bad electrical connections.
- 3 Fault in starter motor.
- 4 Wrong grade of lubricating oil.
- 5 Starter motor turns engine too slowly.
- 6 Fuel tank empty.
- 7 Spare.
- 8 Restriction in a fuel pipe.
- 9 Fault in fuel lift pump.
- 10 Dirty fuel filter element.
- 11 Restriction in air induction system.
- 12 Air in fuel system.
- 13 Fault in the fuel injector units.
- 14 Cold start system used incorrectly.
- 15 Fault in cold start system.
- 16 Restriction in fuel tank vent.
- 17 Wrong type or grade of fuel used.
- 18 Restricted movement of engine speed control.
- 19 Restriction in exhaust pipe.
- 20 Engine temperature is too high.
- 21 Engine temperature is too low.
- 22 Incorrect valve tip clearances.
- 23 Too much oil or oil of the wrong type is used in wet type air cleaner, if one is fitted.
- 24 Not enough lubricating oil in sump.
- 25 Defective gauge.
- 26 Dirty lubricating oil filter element.
- 27 Fan damaged.
- 28 Fault in engine mounting or flywheel housing.
- 29 Too much lubricating oil in sump.
- 30 Restriction in air or water passages of radiator.
- 31 Restriction in breather pipe.
- 32 Insufficient coolant in system.
- 33 Fault in exhauster.
- 34 Spare.
- 35 Spare.
- 36 Spare.
- 37 Valve timing is incorrect.
- 38 Bad compression.
- 39 Cylinder head gasket leaks.
- 40 Valves are not free.
- 41 Spare.
- 42 Worn cylinder bores.
- 43 Leakage between valves and seats.
- 44 Piston rings are not free or they are worn or broken.
- 45 Valve stems and/or guides are worn.
- 46 Crankshaft bearings are worn or damaged.
- 47 Lubricating oil pump is worn.
- 48 Relief valve does not close.
- 49 Relief valve does not open.
- 50 Relief valve spring is broken.
- 51 Fault in suction pipe of lubricating oil pump.
- 52 Piston is damaged.
- 53 Piston height is incorrect.
- 54 Flywheel housing or flywheel is not aligned correctly.
- 55 Fault in thermostat or thermostat is of an incorrect type.
- 56 Restriction in coolant passages.
- 57 Fault in water pump.
- 58 Valve stem seal is damaged.
- 59 Restriction in sump strainer.
- 60 Valve spring is broken.
- 61 Turbocharger impeller is damaged or dirty.
- 62 Lubricating oil seal of turbocharger leaks.
- 63 Induction system leaks.
- 64 Turbocharger waste-gate does not work correctly, if one is fitted.
- 65 Drive belt for water pump is loose.
- 66 Faulty engine management system.
- 67 Broken drive on the high pressure pump.
- 68 Faulty injection control system
- 69 Faulty sensor

7

Engine preservation

Introduction

The recommendations indicated below are designed to prevent damage to the engine when it is withdrawn from service for a prolonged period. Use these procedures after the engine is withdrawn from service. The instructions for the use of POWERPART products are given on the outside of each container.

Procedure

Caution: *The procedure for this engine is different to the procedure for other Perkins engines, because of the design of the fuel injection units.*

- 1 Completely clean the outside of the engine.
- 2 Operate the engine until it is warm. Stop the engine and drain the lubricating oil from the sump. Ensure that the oil gallery of the high-pressure lubrication system is drained.

Caution: *If the gallery is not drained, the engine cylinders will be filled with engine lubricating oil when the fuel injector units are removed.*

- 3 Disconnect the battery.
- 4 Disconnect the air inlet pipe at the rocker cover. Release the setscrews and remove the rocker cover. Spray POWERPART Lay-Up 2 around the rocker shaft assembly and into the induction ports in the cylinder head, as indicated on the container label.
- 5 Drain the fuel supply gallery, fitted to the cylinder head.

Caution: *If the gallery is not drained, the engine cylinders will be filled with fuel when the fuel injector units are removed.*

- 6 Remove the fuel injector units, see section 20A of the Workshop Manual, and spray POWERPART Lay-Up 2 for one to two seconds into each cylinder bore with the piston at bottom dead centre.
- 7 Slowly turn the crankshaft one revolution and then fit the fuel injector units, complete with new seat washers.
- 8 Fit the rocker cover and connect the air inlet pipe.
- 9 Renew the canister of the lubricating oil filter, see page 4.12.
- 10 Fill the sump to the full mark on the dipstick with new and clean lubricating oil and add POWERPART Lay-up 2 to the oil to protect the engine against corrosion. If POWERPART Lay-Up 2 is not available, use a correct preservative fluid instead of the

lubricating oil. If a preservative fluid is used, this must be drained and the lubricating oil sump must be filled to the correct level with normal lubricating oil at the end of the storage period.

- 11 Drain the coolant circuit, [see page 19](#). In order to protect the cooling system against corrosion, fill it with an approved antifreeze mixture because this gives protection against corrosion.

Caution: *If protection against frost is not necessary and a corrosion inhibitor is to be used, it is recommended that you consult the Technical Service Department, Perkins Engines Company Limited, Peterborough.*

- 12 Connect the battery, eliminate air from the fuel system. Operate the engine for a short period in order to circulate the lubricating oil and the coolant in the engine. Then correct leakages of fuel, lubricating oil or air.

- 13 Disconnect the battery. Then put the battery into safe storage in a fully charged condition. Before the battery is put into storage, protect its terminals against corrosion. POWERPART Lay-Up 3 can be used on the terminals.

- 14 Remove the air filter. Then, if necessary, remove the pipe(s) installed between the air filter and the turbocharger. Seal the air inlet to the turbocharger with waterproof tape.

- 15 Remove the exhaust pipe. Spray POWERPART Lay-Up 2 into the exhaust manifold or the turbocharger. It is recommended that the spray time for the turbocharger is 50% longer than the spray time for the manifold, which is indicated on the container label. Seal the manifold or the turbocharger with waterproof tape.

- 16 Clean the engine breather pipe and seal the end of the pipe.

- 17 When a preservative fuel is to be used, drain the fuel system and fill it with the preservative fuel. POWERPART Lay-Up 1 can be added to the normal fuel to change it to a preservative fuel. If preservative fuel is not used, the system can be completely filled with normal fuel but the fuel must be drained and discarded at the end of the storage period together with the fuel filter canister.

Continued

18 Remove the drive belts and put them into storage.

19 Seal the vent pipe of the fuel tank or the fuel filler cap with waterproof tape.

20 In order to prevent corrosion, spray the engine with POWERPART Lay-Up 3. Do not spray the area inside the alternator cooling fan.

If the engine protection is done correctly according to the above recommendations, no corrosion damage will normally occur. Perkins are not responsible for damage which may occur when an engine is in storage after a period in service.

8

Parts and service

Introduction

If problems occur with your engine or with the components fitted onto it, your Perkins distributor can make the necessary repairs and will ensure that only the correct parts are fitted and that the work is done correctly.

Service literature

Workshop manuals, installation drawings and other service publications are available from your Perkins distributor at a nominal cost.

Training

Local training for the correct operation, service and overhaul of engines is available at certain Perkins distributors. If special training is necessary, your Perkins distributor can advise you how to obtain it at the Perkins Customer Training Department, Peterborough, or other main centres.

POWERPART recommended consumable products

Perkins have made available the products recommended below in order to assist in the correct operation, service and maintenance of your engine and your machine. The instructions for the use of each product are given on the outside of each container. These products are available from your Perkins distributor.

POWERPART Antifreeze

Protects the cooling system against frost and corrosion. Part number 1 litre 21825166 or 5 litres 21825167.

POWERPART Atomiser thread sealant

To seal the threads of the atomiser into the cylinder head. Currently Hylomar Advance Formulation.

POWERPART Chisel

Allows easy removal of old gaskets and joints. Currently Loctite chisel. Part number 21825163.

POWERPART Compound

To seal the outer diameter of seals. Currently Loctite Forma Gasket No 2. Part number 1861147.

POWERPART Easy Flush

Cleans the cooling system. Part number 2182501.

POWERPART Gasket eliminator

Improves flange sealing when a gasket is not used. It provides a seal with temperature resistance that is flexible in positions where vibration and pressure occur.

Currently Loctite 515. Part number 21826040.

POWERPART Jointing compound

Universal jointing compound which seals joints. Currently Hylomar. Part number 1861155 or 1861117.

POWERPART Lay-Up 1

A diesel fuel additive for protection against corrosion. Part number 1772204.

POWERPART Lay-Up 2

Protects the inside of the engine and of other closed systems. Part number 1762811.

POWERPART Lay-Up 3

Protects outside metal parts. Part number 1734115.

POWERPART Liquid gasket

To seal flat faces of components where no joint is used. Especially suitable for aluminium components. Currently Loctite 518. Part number 21820518

POWERPART Nutlock

To retain and seal threaded fasteners and cup plugs where easy removal is necessary.

Currently Loctite 242e. Part number 21820242

Continued

POWERPART recommended consumable products
Continued

POWERPART Platelock

Medium strength anaerobic threadlock for tight fitted metal surfaces. Suitable for metal plated surfaces and stainless steel.

Currently Loctite 243. Part number 21826039.

POWERPART Repel

Dries damp equipment and gives protection against corrosion. Passes through dirt and corrosion to lubricate and to assist removal of components.

Currently Loctite repel. Part number 21825164.

POWERPART Retainer (high strength)

To retain components which have an interference fit.

Currently Loctite 638. Part number 21820638.

POWERPART Retainer (oil tolerant)

To retain components which have a transition fit.

Currently Loctite 603. Part number 21820603.

POWERPART Silicone adhesive

An RTV silicone adhesive for application where low pressure tests occur before the adhesive sets. Used for sealing flange where oil resistance is needed and movement of the joint occurs.

Currently Loctite 5900. Part number 21826038.

POWERPART Silicone rubber sealant

Silicone rubber sealant which prevents leakage through gaps.

Currently Hylosil. Part number 1861108.

POWERPART Studlock

To permanently retain large fasteners and studs.

Currently Loctite 270. Part number 21820270.

POWERPART Threadlock

To retain small fasteners where easy removal is necessary.

Currently Loctite 222e. Part number 21820222.

POWERPART Threadlock (heavy duty)

To provide a heavy duty seal to components that have a light interference fit.

Currently Loctite 262. Part number 21820262.

POWERPART Threadlock (hydraulic/pneumatic)

To retain and seal pipe connections with fine threads. Especially suitable for hydraulic and pneumatic systems.

Currently Loctite 542. Part number 21820542

POWERPART Threadlock (pipe)

To retain and seal pipe connections with coarse threads. Pressure systems can be used immediately.

Currently Loctite 575. Part number 21820575.

9

General data

Engine

Number of cylinders.....	6
Cylinder arrangement.....	In line
Cycle.....	Four stroke
Induction system.....	Turbocharged or Turbocharged/intercooled
Combustion system.....	Direct injection
Nominal bore:	
- WK and WL	109,2 mm (4.301 in)
- WM and WN	116,6 mm (4.590 in)
Stroke:	
- WK and WL	118,9 mm (4.681 in)
- WM and WN	135,9 mm (5.350 in)
Compression ratio	16.5:1
Cubic capacity:	
- WK and WL	7,64 litres (466.4 in ³)
- WM and WN	8,71 litres (531.0 in ³)
Firing order	1, 5, 3, 6, 2, 4
Valve tip clearances (cold):	
- Inlet and exhaust.....	0,64 mm (0.025 in)
Lubricating oil pressure (minimum):	
- Idle.....	137 kPa (20 lbf/in ²) 1,4 kgf/cm ²
- maximum engine speed and normal engine temperature	276 kPa (40 lbf/in ²) 2,8 kgf/cm ²
Capacity of a typical lubricating oil sump (1):	
- Without filter canister.....	22,7 litres (40.0 UK pints) 24 US quarts
- With filter canister.....	28,3 litres (49.9 UK pints) 28 US quarts
Typical coolant capacity (engine only).....	12,8 litres (22.5 UK pints) 13,5 US quarts
Direction of rotation	Clockwise from the front

(1) The capacity of the sump may vary according to the application. Fill to the "Full" mark on the dipstick. Do not exceed the "Full" mark.

