

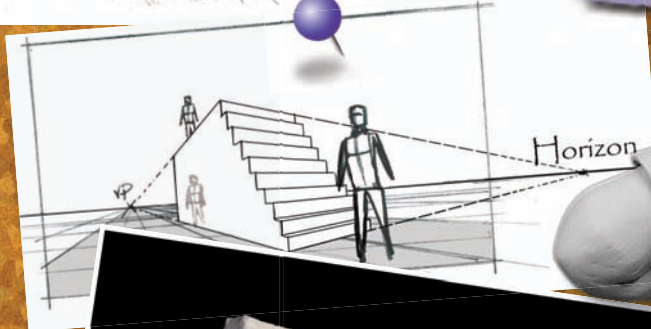

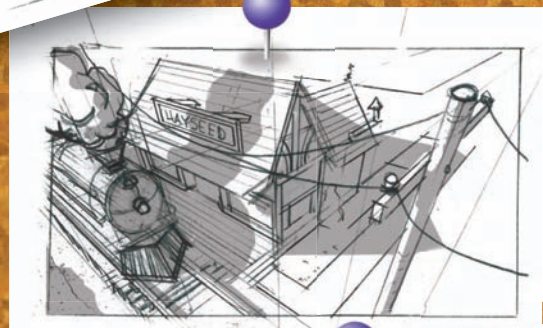

# 2 Perspectives

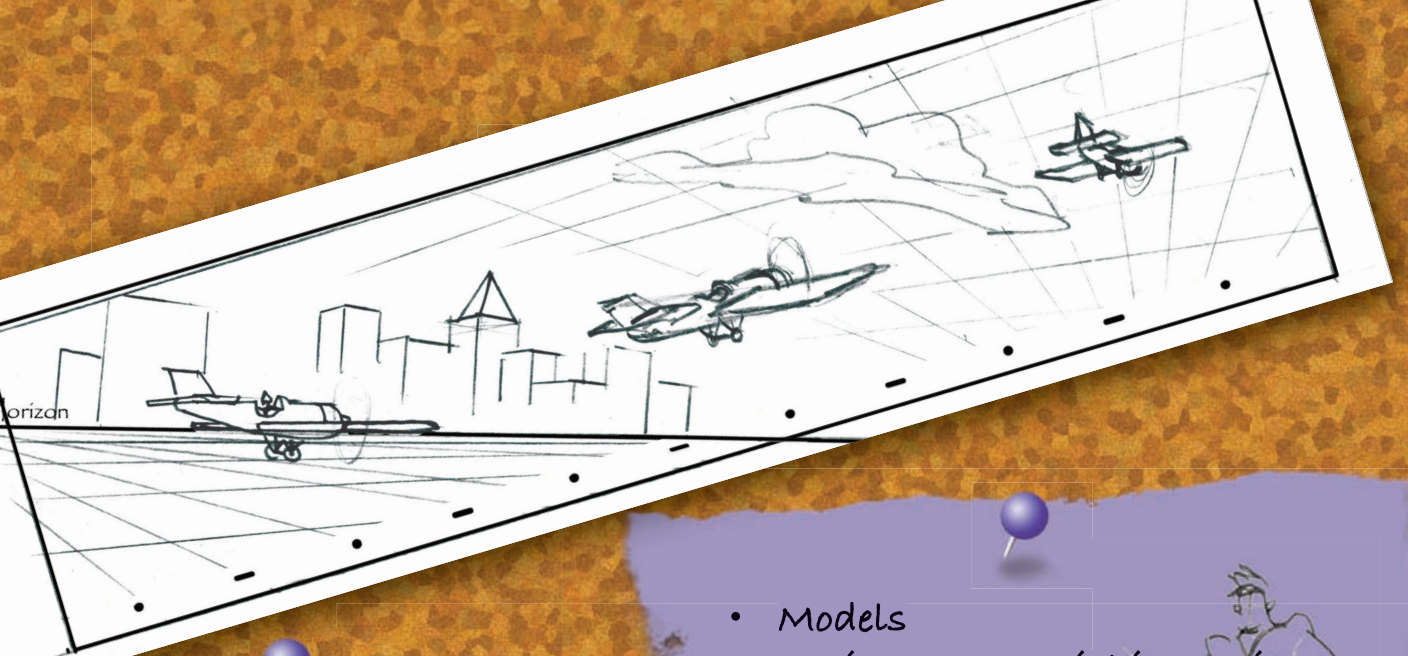

- Models
  - Horizons & Vanishing Points
  - Multiple Horizons & Vanishing Points
  - Values & Vanishing Points
  - Tricks
- 



© Disney Enterprises, Inc.

© Disney Enterprises, Inc.

## This chapter...

covers the first steps in the drawing process.

Horizons and vanishing points are the basics of all drawings. Knowing how to put things in proper perspective can keep a drawing from looking off-balance and out of skew.

Characters must move, emote, and be dynamic to appear authentic to an audience. However, this illusion of authenticity can be lessened if the world these characters live in does not seem equally dynamic and if the characters do not seem properly anchored within it.

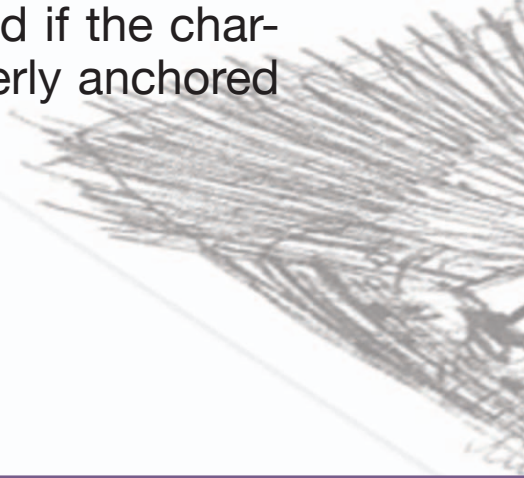

This chapter also discusses how to use multiple horizons and vanishing points to create a more dynamic composition and a more interesting story.

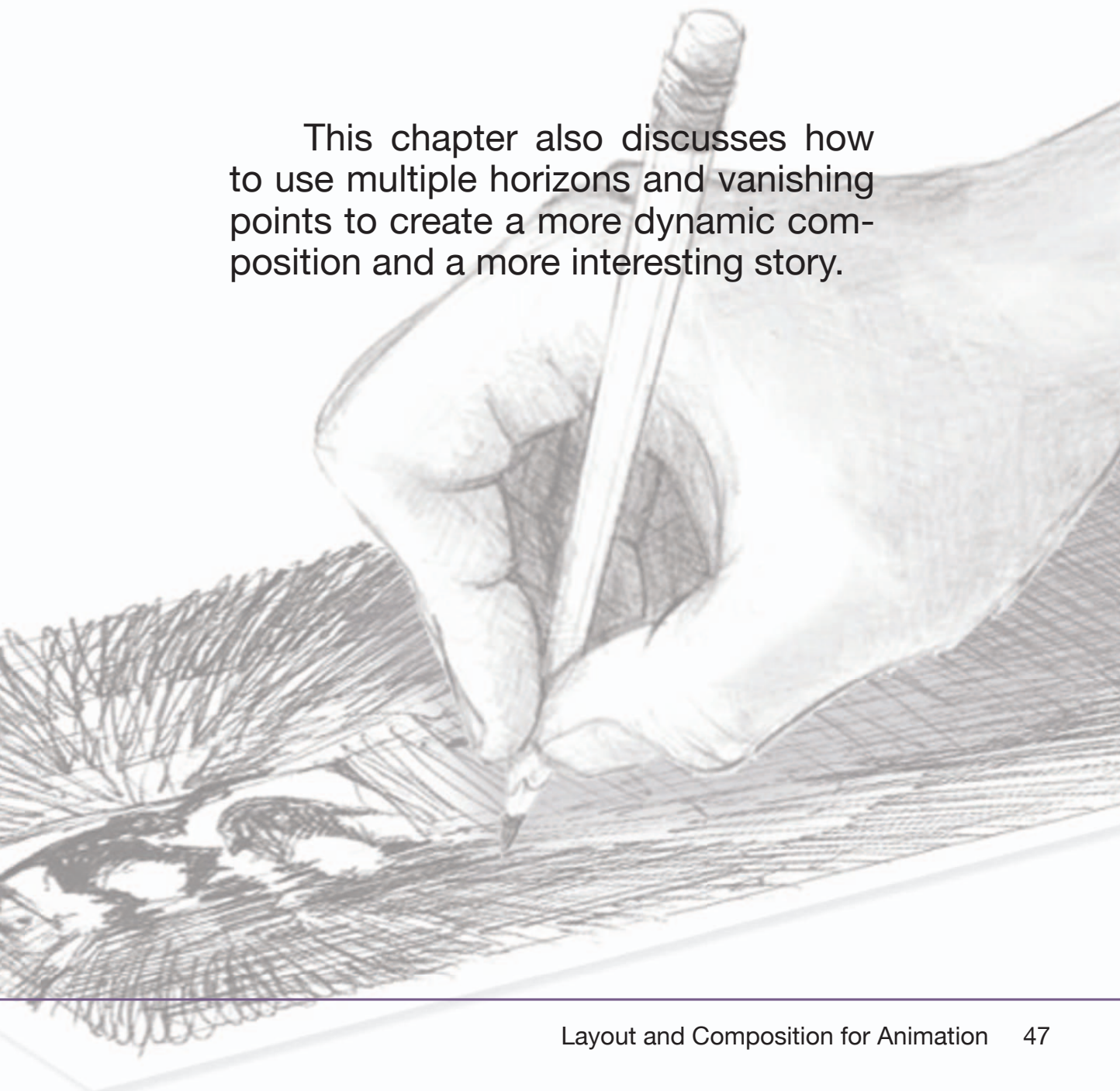

# M odels

## Models

After finding the horizons and vanishing points in a composition, one can place characters and objects into the drawing in a way that “seats” them properly in that space.

### Character Maquettes for Disney's ATLANTIS



Placement of objects within the composition can affect scale. The common approach is to place the characters in the composition so that they match a realistic size to the other objects within, but you might like to caricature the scale of the characters larger or smaller to give a cartoon or comic feel.

Three-dimensional models can help an artist to better understand the shapes of

things since this model can be seen from all angles. Similarly, character artists are provided with character sculptures, or “maquettes”.

Computer animation allows for simple models of background and objects to be built in virtual space, and artists can now use these as a guide for perspective shots.



# Models

## Traditional Layout Models

Here are photographs of three-dimensional layout models for some of the 2-D projects I've worked on.



© Disney Enterprises, Inc.



© Disney Enterprises, Inc. Based on the "Winnie the Pooh" works, by A.A. Milne and E.H. Shepard.



© Disney Enterprises, Inc.

- 1 Disney's "Atlantis" (Feature)
- 2 Tigger's House  
(from Disney's "The Many Adventures of Winnie the Pooh" TV Series)
- 3 Disney's "Black Cauldron" (Feature)
- 4 Halloween Project (personal)



# Models

## CGI Layout Models

The modeling process is similar in computer graphics. A concept design is created, and elevations are drawn — top, sides, front and back — of any objects to be built in the computer. Here is an example of the computer model design process.

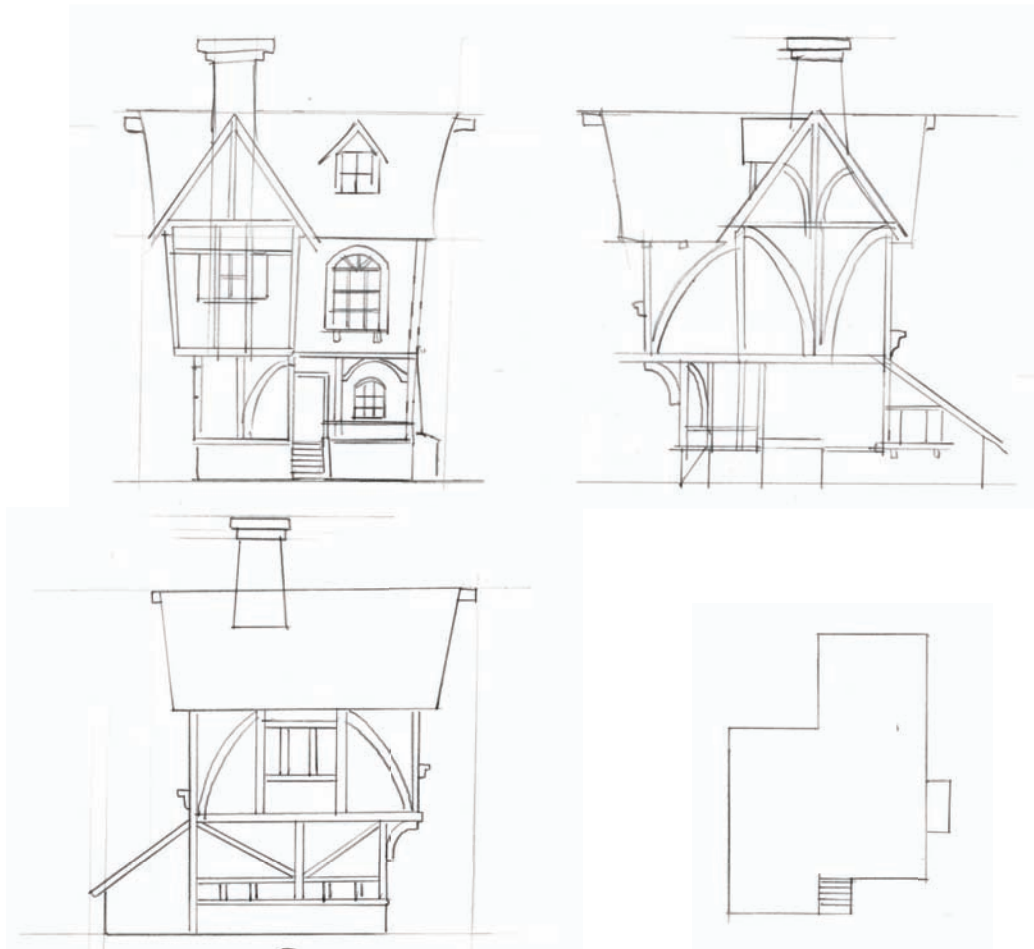

Linear elevation drawings

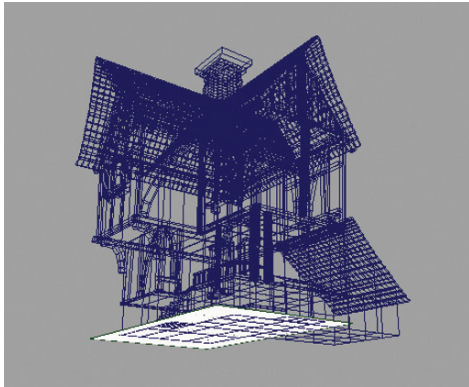

Wireframe based on linear drawings



Smooth-shaded over wireframe



Final color comp

# Horizons & Vanishing Points

## Using a Perspective Grid

The first thing to create is the position of the horizon line. All vanishing points will be positioned on this horizon. (There are exceptions to this rule, and we'll cover multiple horizons and vanishing points in another chapter.)

A perspective grid is necessary for this. Grids can be purchased at an art supply store to be used underneath your drawing on a light board, or if you're working on the computer, you can scan one in and place it over your drawing as a layer. While working in Photoshop, I always start my compositions this way, turning the grid layer on and off as I work through the design.

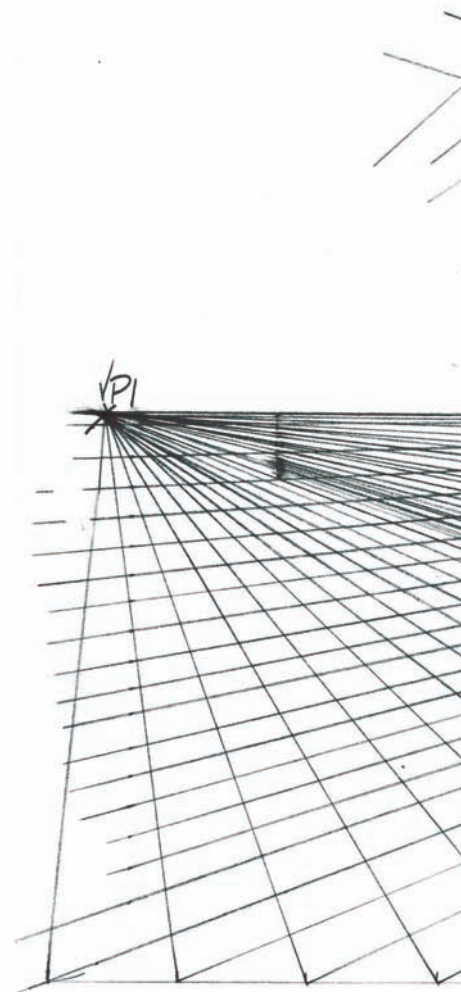

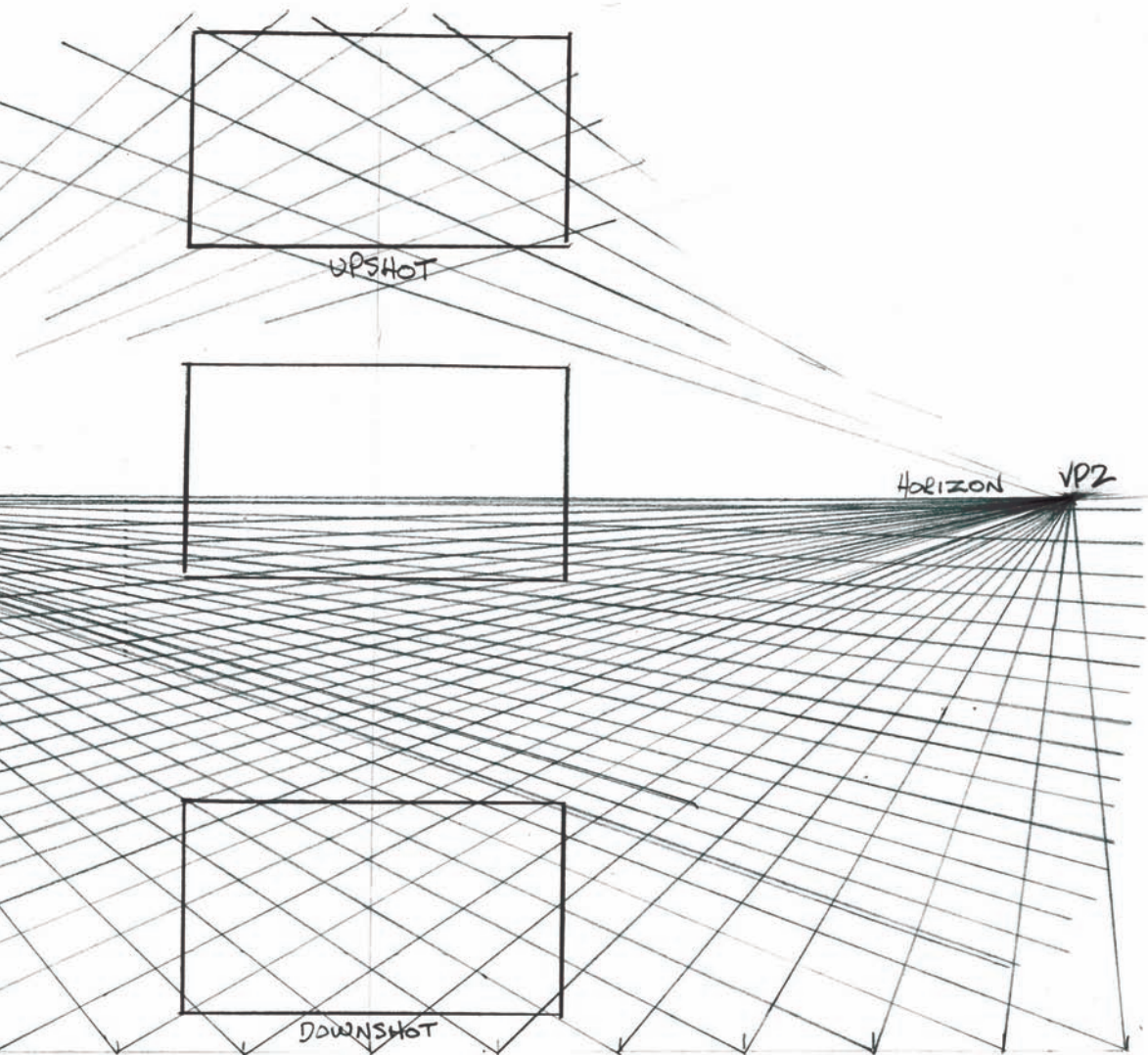

# Horizons & Vanishing Points

## Perspective Grid Related to Horizon & Vanishing Points

Here are three examples of the position of the horizon and vanishing points most often used.

The vanishing points create the grid that represents the ground plane (which I'll speak to later in this chapter).

In the common eye level, the horizon is in the middle of the screen. The center of the picture plane (or field) floats just above the horizon line.

In a down shot, the horizon is either at the top, or as shown here, actually off the picture plane.

In an up shot, the center of the picture plane is above the horizon.

- 1 Picture plane with a rough position of the horizon.
- 2 Rough horizon with vanishing points that create perspective grid.

### Common Eye Level

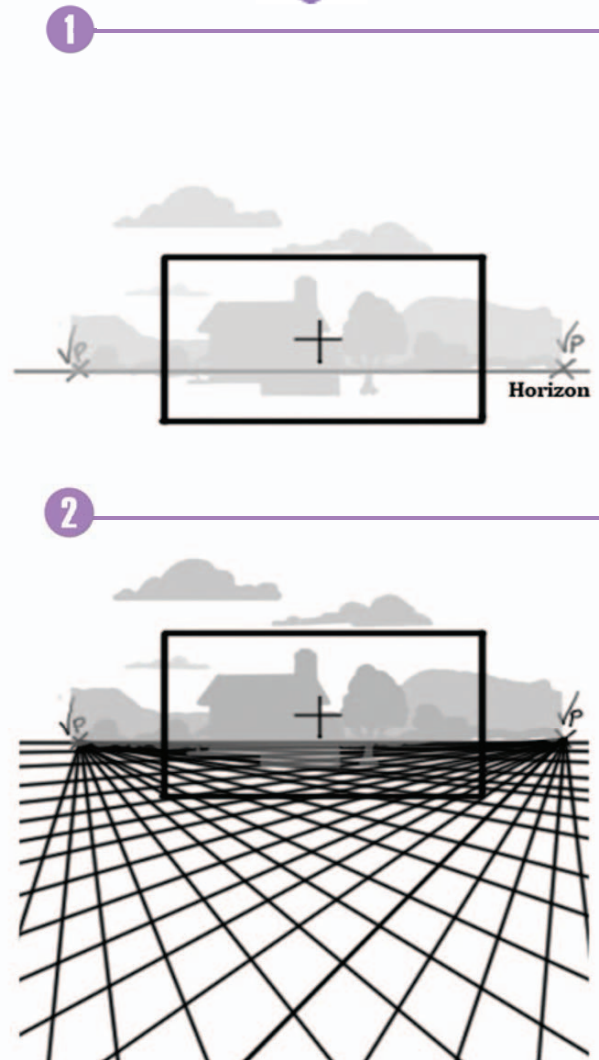

## Down Shot

## Up Shot

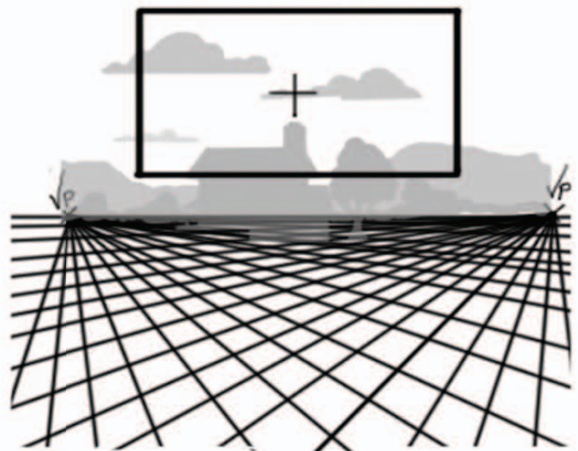
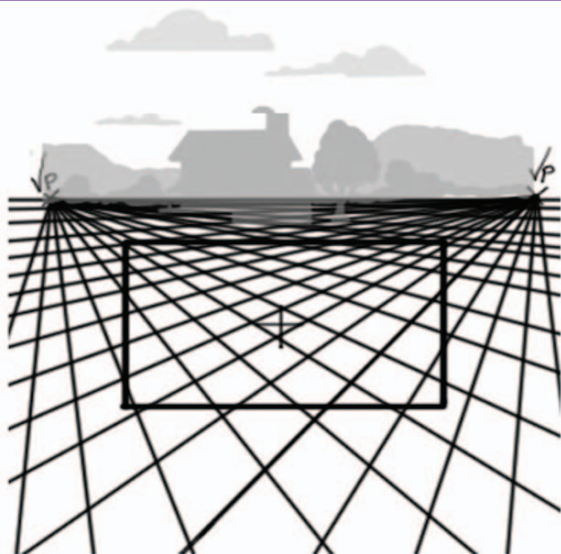

# Horizons & Vanishing Points

## Interior Limitations

Within an interior, a common mistake is to place objects on the horizon rather than at the correct placement within the perspective grid. The examples to the right will show you what could happen should this incorrect placement occur.

In example 1, the characters are placed on the perspective grid. However, if the room they will be placed in has been conceived with the back wall placed directly on the horizon, the room looks huge, making the character at the back look tiny and out of proportion (example 2). The back wall should instead be placed forward of the horizon line to the size proportion of the characters as shown in example 3.

Knowing the placement or action of the characters in the shot is important to creating proper perspective within the layout.

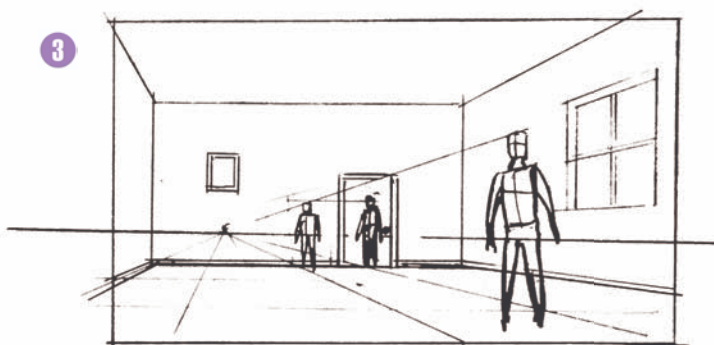
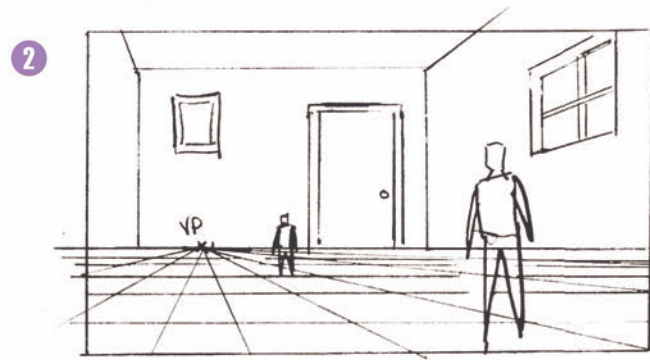
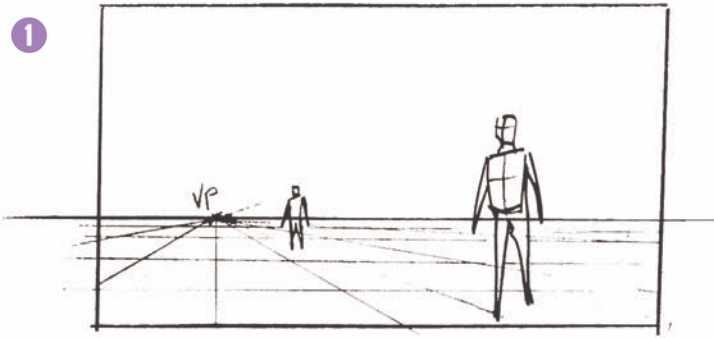



# Horizons & Vanishing Points

## Object and Character Placement on Uneven Ground Planes

As shown in example 1, if the horizon is waist high on a character in the foreground, it will be waist high wherever the character is placed or moves within the picture plane. The exception is if the ground plane raises or lowers, or the character walks up or down stairs (example 3), hills, or, as hap-

pens often in animated film, they fly.

Example 2 shows that a character might have to walk or be placed on a curved ground plane. As before, find the height of the character vertically placing him or her on the curved plane.

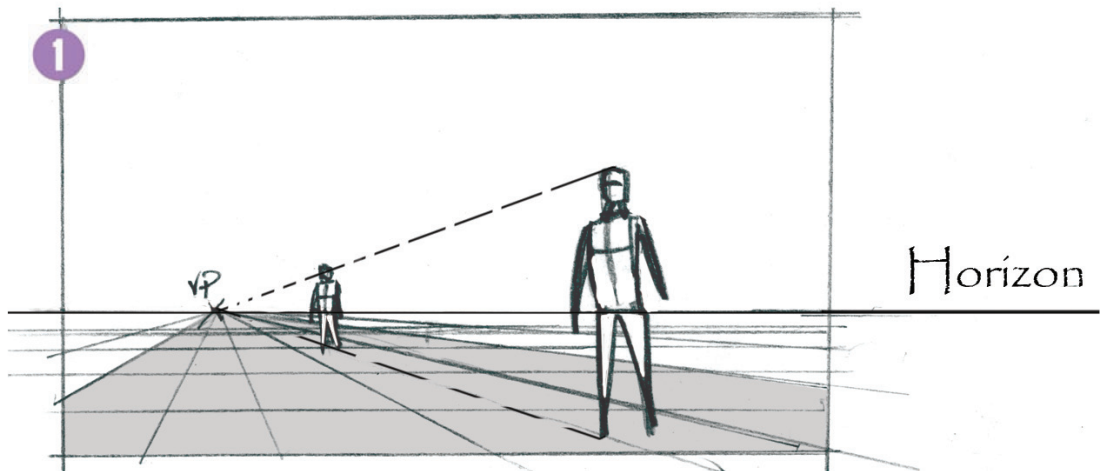

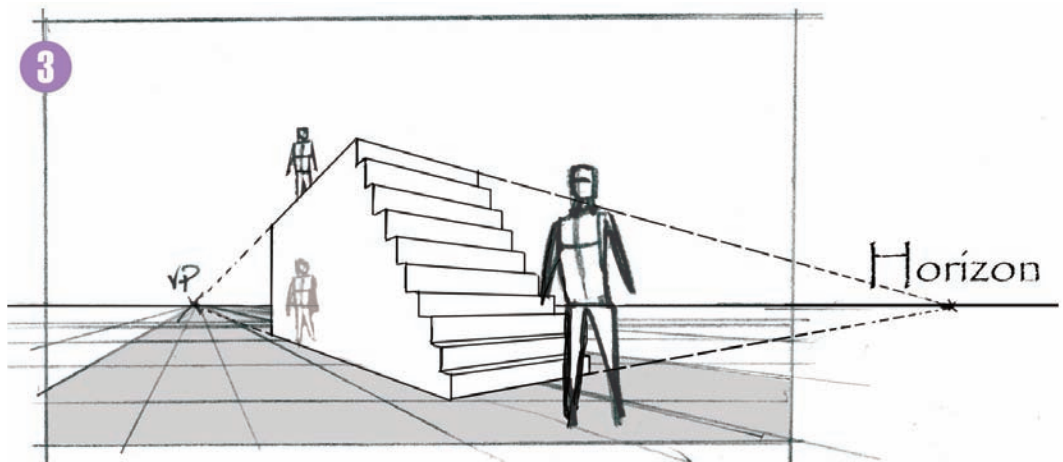
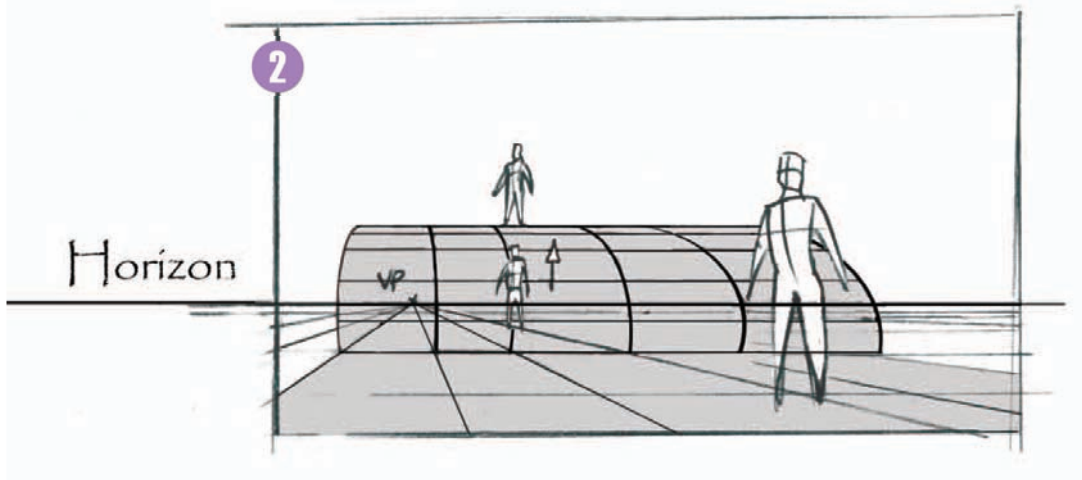

# Horizons & Vanishing Points

## Creating Objects with Exacting Measurements in Perspective

Occasionally, a layout artist will be called upon to place objects at specific physical measurements within the picture plane. Each inch can represent any particular unit of measurement. In this case, each inch represents one inch. But it could also represent a foot, or a mile.

Drawing a line from point A to VP1 and a line from point B to VP2 will give you a point in space that defines the point where C will be on the ground plane perspective. With this knowledge, the plane can be placed anywhere in space by using the vanishing points.

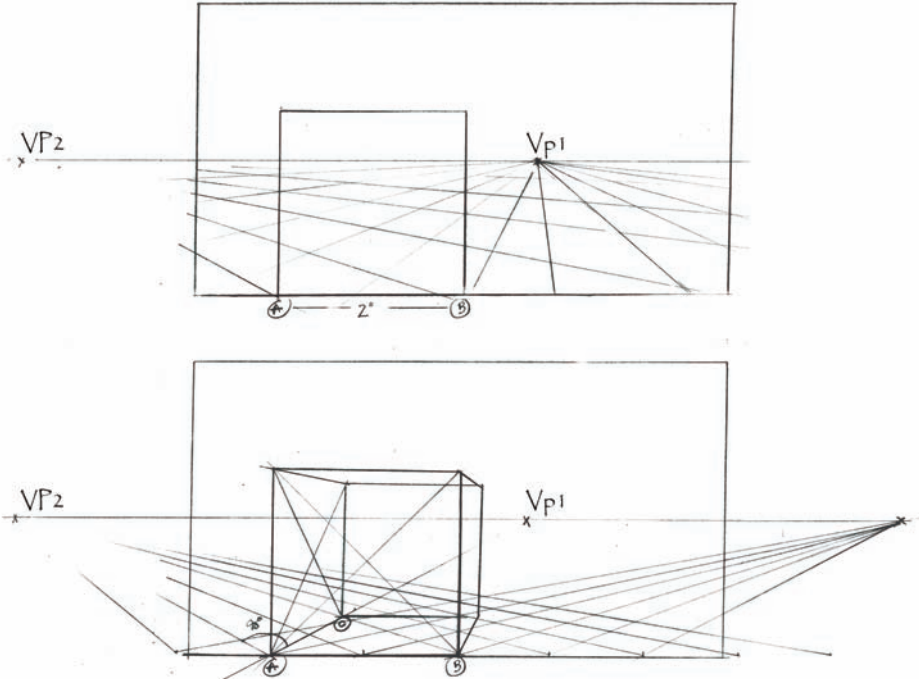

For example, if it is known that the two lines drawn 8-inches left and right of center are connected to VP2 and VP3, they will intersect 8-inches into the picture from the picture plane.

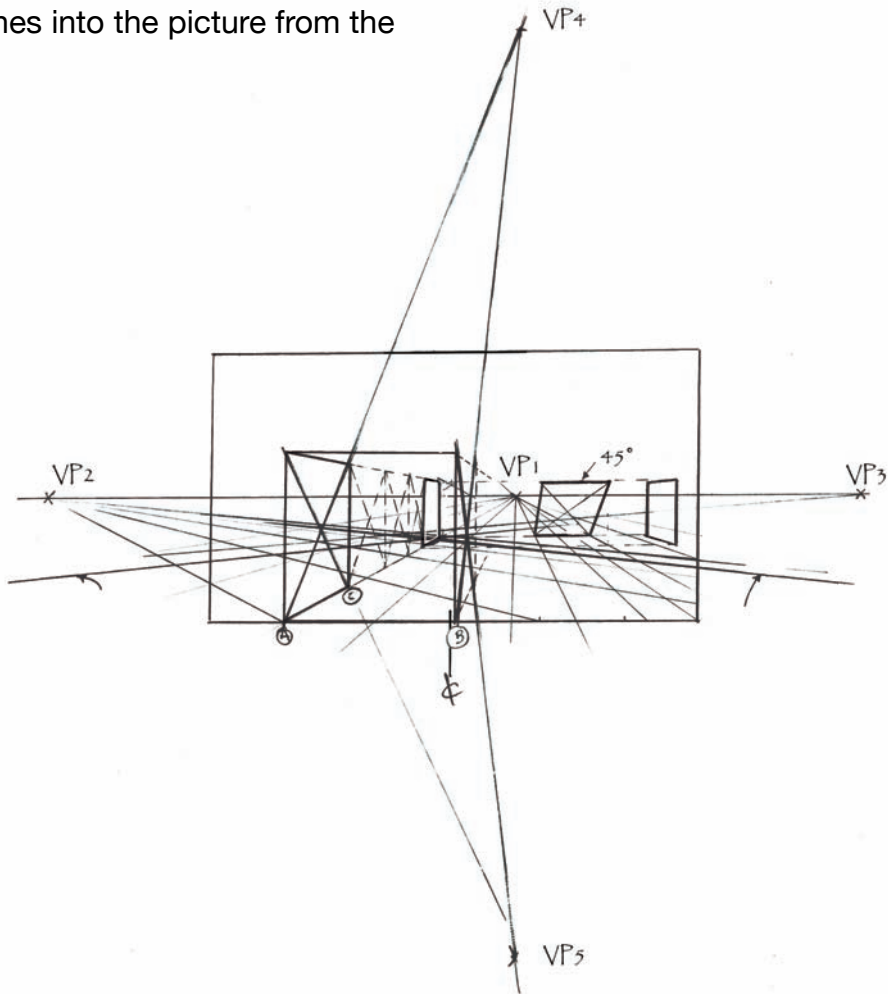

# Multiple Horizons & Vanishing Points

## A Horizon on the Horizon

There are situations when composing for film, where a character's position in the composition works at one position, but not in another within the same field. The easy way out would be to add a camera move, but there are times when you don't want to move the camera, or you can't.

The solution is to find where your character fits in the fielding, then work from that position out. In this example of a narrow hallway that leads to a doorway (frame 1), the character will travel from the foreground down the hallway, and through the door. To get the perspective right, I start by positioning the character in the doorway (frame 2) since I know how tall he is in comparison. This composition is a one-point perspective shot, so I've chosen a vanishing point on the horizon line shown in blue.

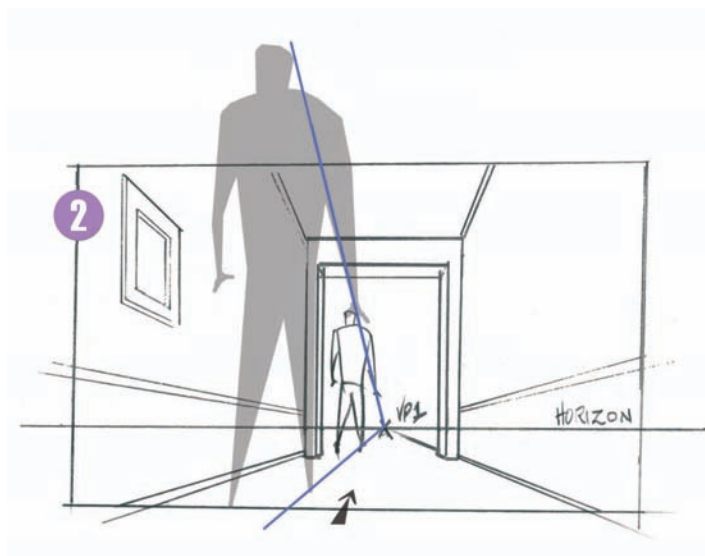
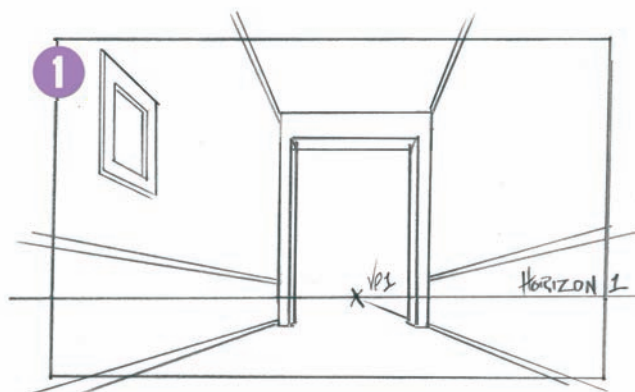

drew a line from the vanishing point on the horizon, through the top of the character's head and out past the picture plane.

Next, draw a line from the same vanishing point on the horizon out through the feet of the character and out past the picture plane. Now you have the perspective plane your character will travel on, into the field, or out.

As you can see, the character starts off screen (frame 3). In computer graph-

ics and live-action, you can change this by changing the lens ratio, but in a drawing you'll have to "cheat" the perspective to simulate a lens change.

The solution is to add another horizon and vanishing point. To start, let's use the character in the doorway with the horizon and vanishing point from frame 2. Once again, draw a line from the vanishing point through the feet of the character in the doorway and out past the picture plane.

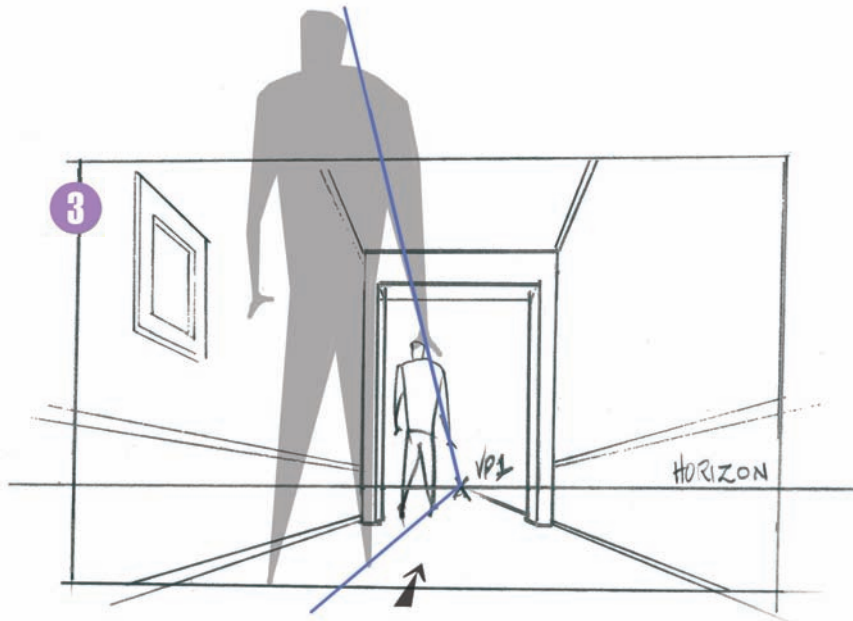

# Multiple Horizons & Vanishing Points

Now draw the character in the foreground so that he fits in the picture plane with his feet on the line just drawn (frame 4). With both characters in their most extreme positions within the frame, draw a line from VP 1 through the head of the character in the doorway. Continue that line through the head of the character in the place it will stand in the foreground, and then out through the picture plane (the lines drawn here in blue). You will notice that it doesn't cross the horizon line. That's okay. Draw a

vertical line from the vanishing point on the horizon until it crosses the line just drawn through the heads of the character. The point where the lines meet will give you the position for the second horizon line and vanishing point. The "cheat" is that any vanishing lines on the background will be in between, or split between the two horizons and vanishing points. The chair rails and picture on the wall are examples of "the cheat" (depicted by the red lines).

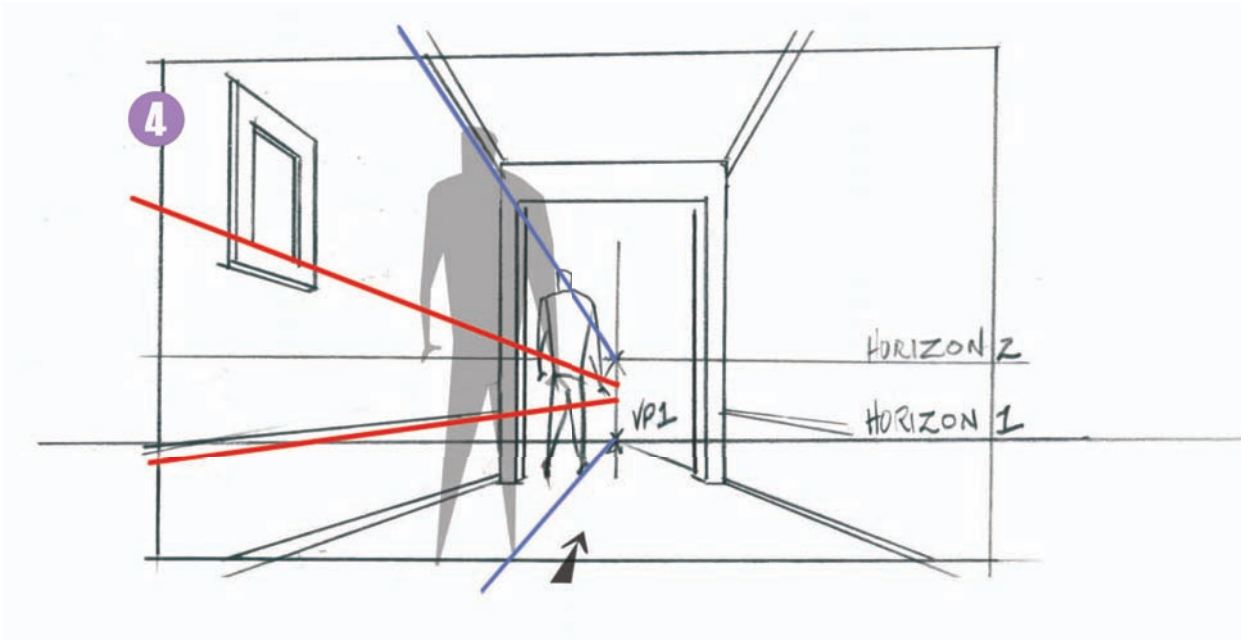



# Multiple Horizons & Vanishing Points

When designing a layout, always check to make sure the characters can be clear and visible to the audience. A object in the background should not have a similar shape and size to the character. If it's necessary to a similar shape, lighting can help by splitting that shape by placing a shadow

across it. A situation that might come up is having a background with a strong one-point perspective in the set-up. It can be very difficult for some animators to act as well as animate in perspective. To help this, accentuate the perspective in an establishing shot and minimize the perspective

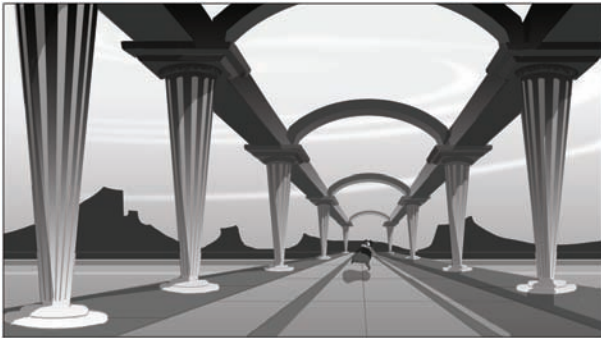

tive in the acting closer shot. If it's necessary to have a strong perspective in the scene with the animation moving on the perspective angle, an overlay intelligently placed over the animation can help hide a miscue in the perspective of the animation.

If a strong perspective is needed, have

the animation cross the perspective line; you'll have the depth of the background but the animation can be almost parallel to the picture plane allowing the animator to focus more on the acting.

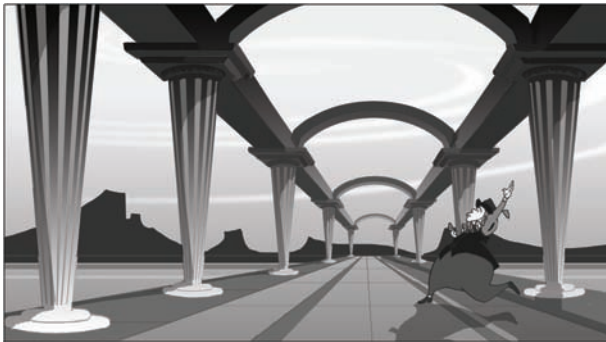

# Multiple Horizons & Vanishing Points

## Feet on the Ground

You can get away with almost any perspective on a character as long as the contact points (usually the feet) work with the same horizon as the background.

Close-ups have other clues to solidify the characters and background. Since we use the same horizon for both, in a close-up, the eyes and shoulder planes describe where the horizon sits.

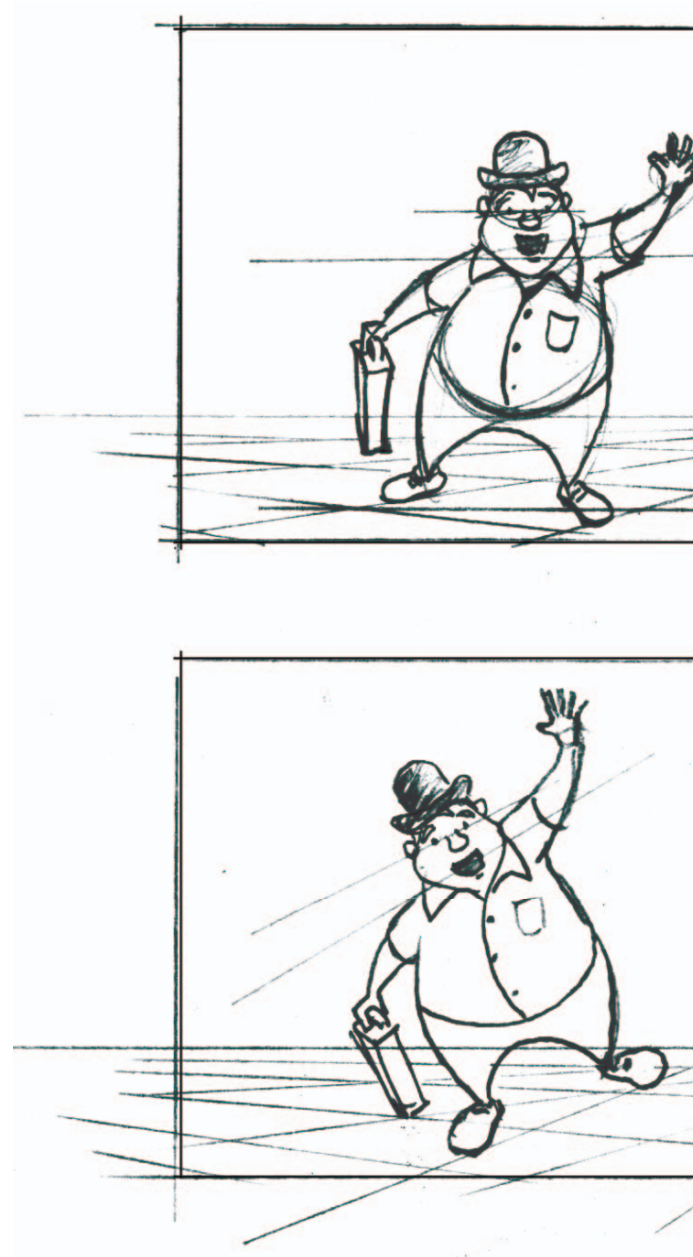

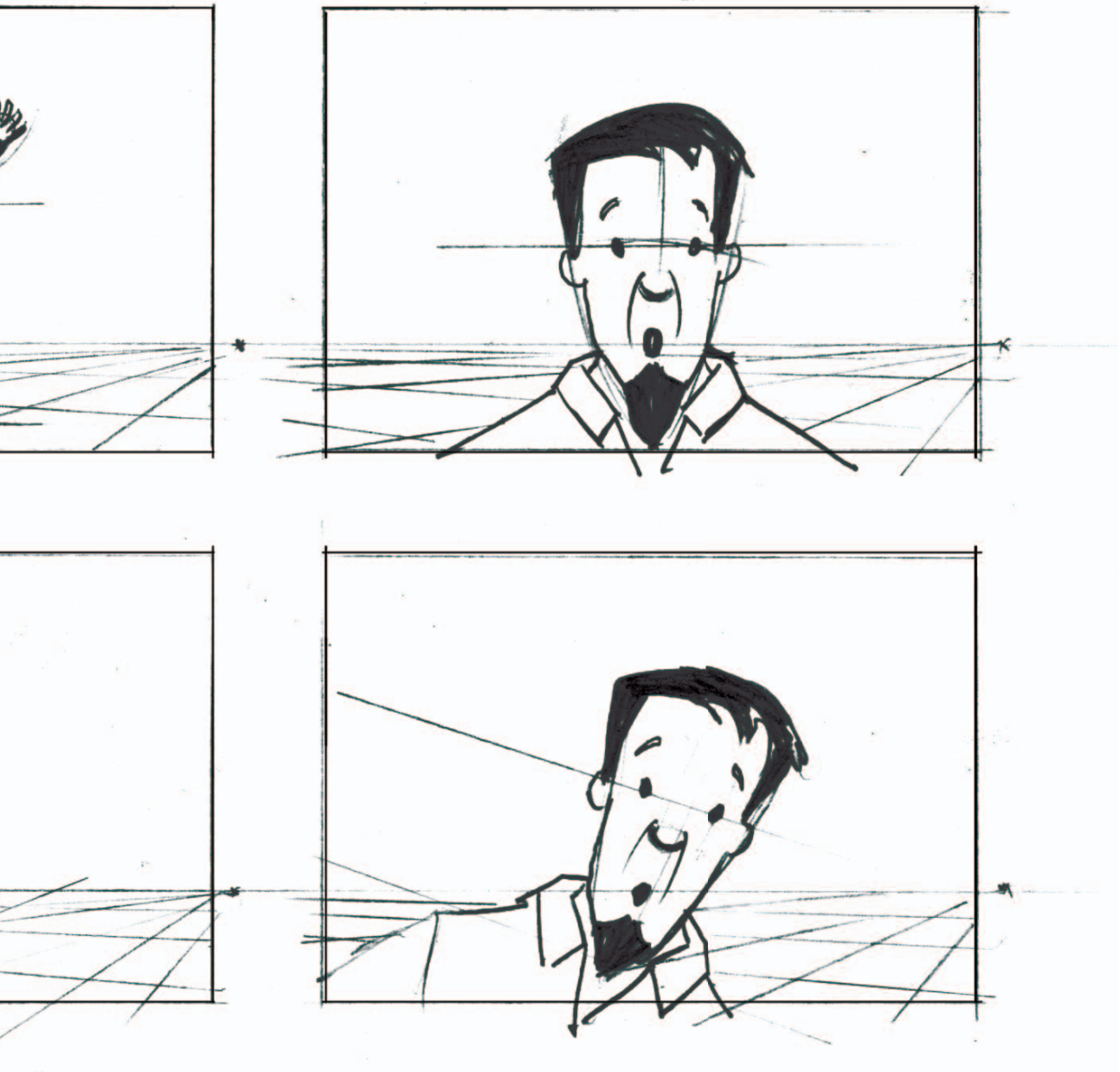

# Multiple Horizons & Vanishing Points

## What's Your Point?

Here are several examples of various perspectives as compared to a typical one-point perspective. Notice how the shot angle affects the perspective in each.

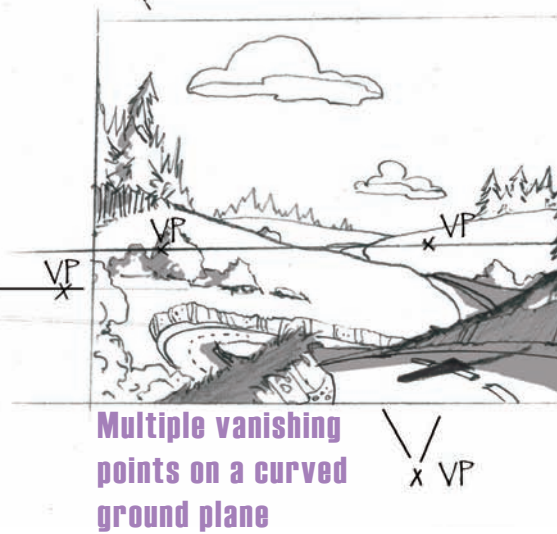
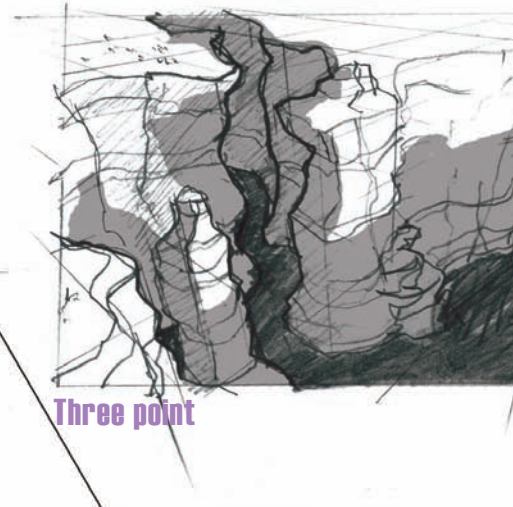
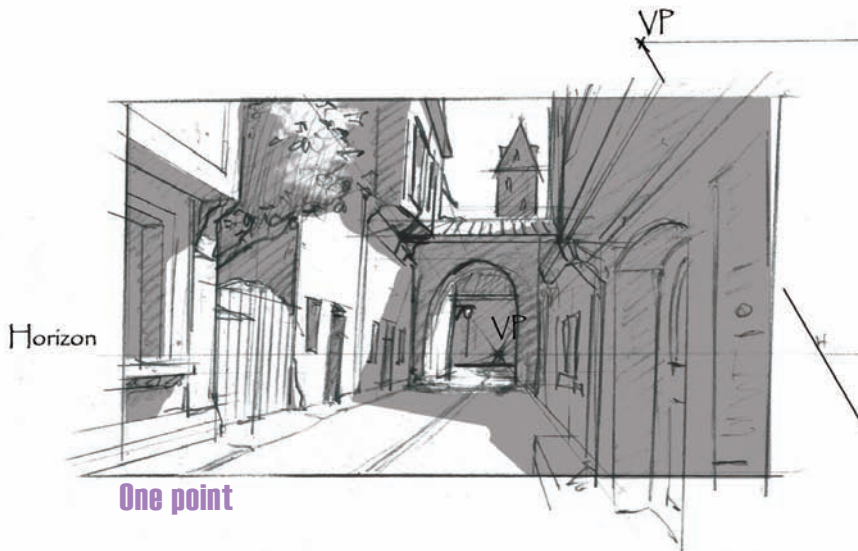

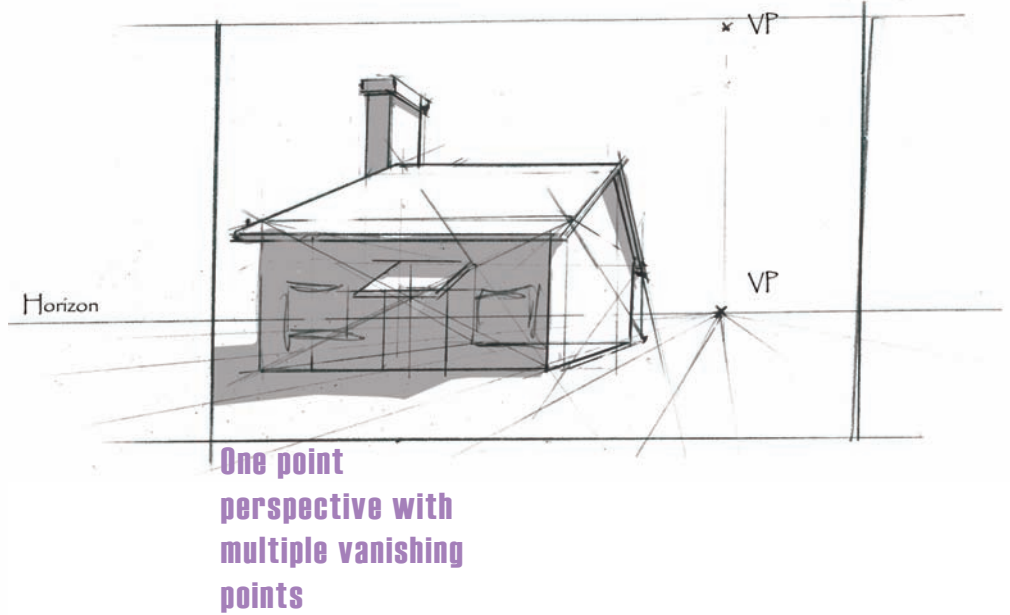
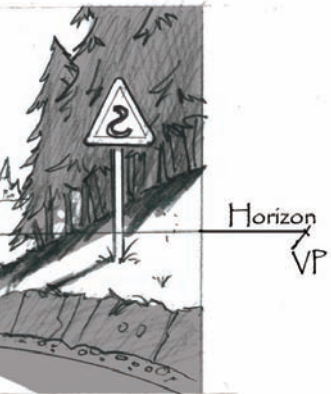
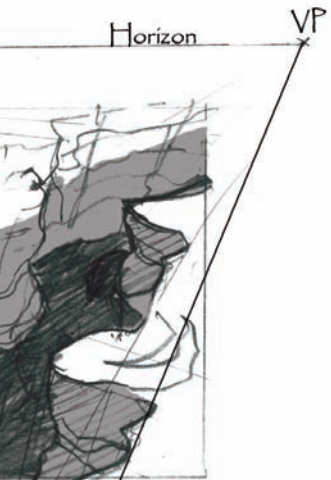
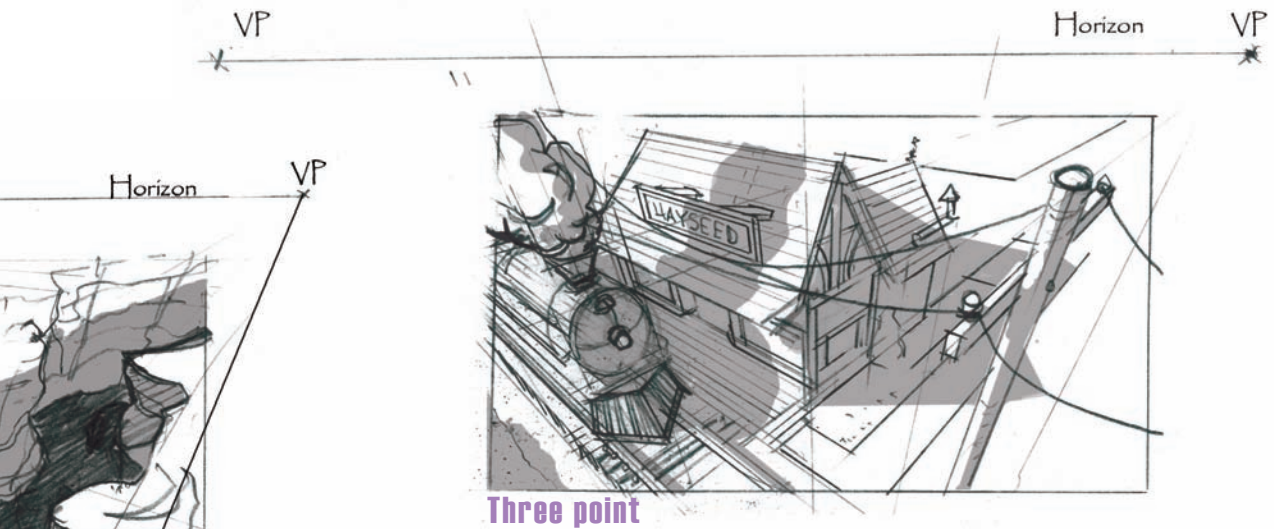

# Multiple Horizons & Vanishing Points

## Inclining/Reclining Planes

Use multiple vanishing points to find the correct perspective for inclining and reclining planes such as stairs, hills, ramps, leaning, boards, etc.

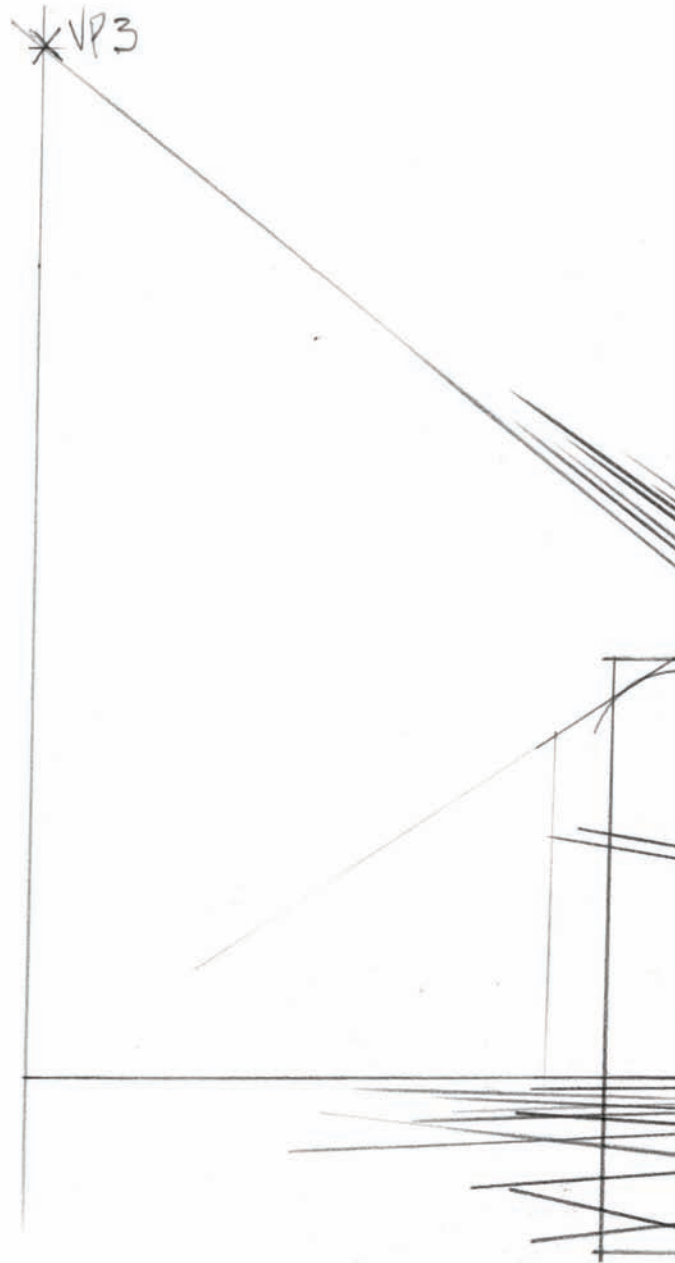

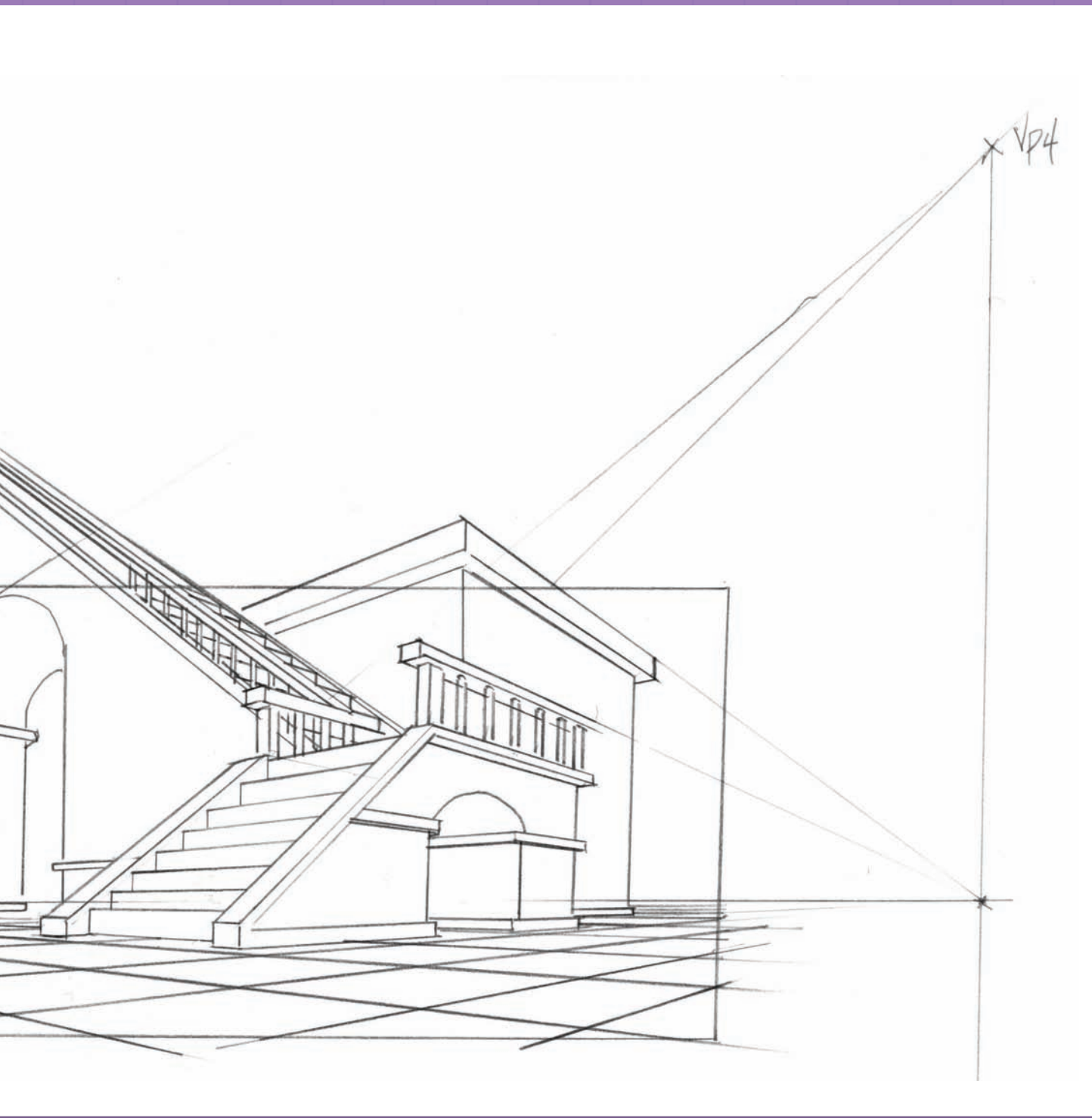



# Values & Vanishing Points

## Value Added

The style of the composition will be a factor in how difficult your project will be. A line drawing will give a different look than a rendered drawing will. At times it might be necessary to drop some of the line work and add value shapes to the design to support the composition.

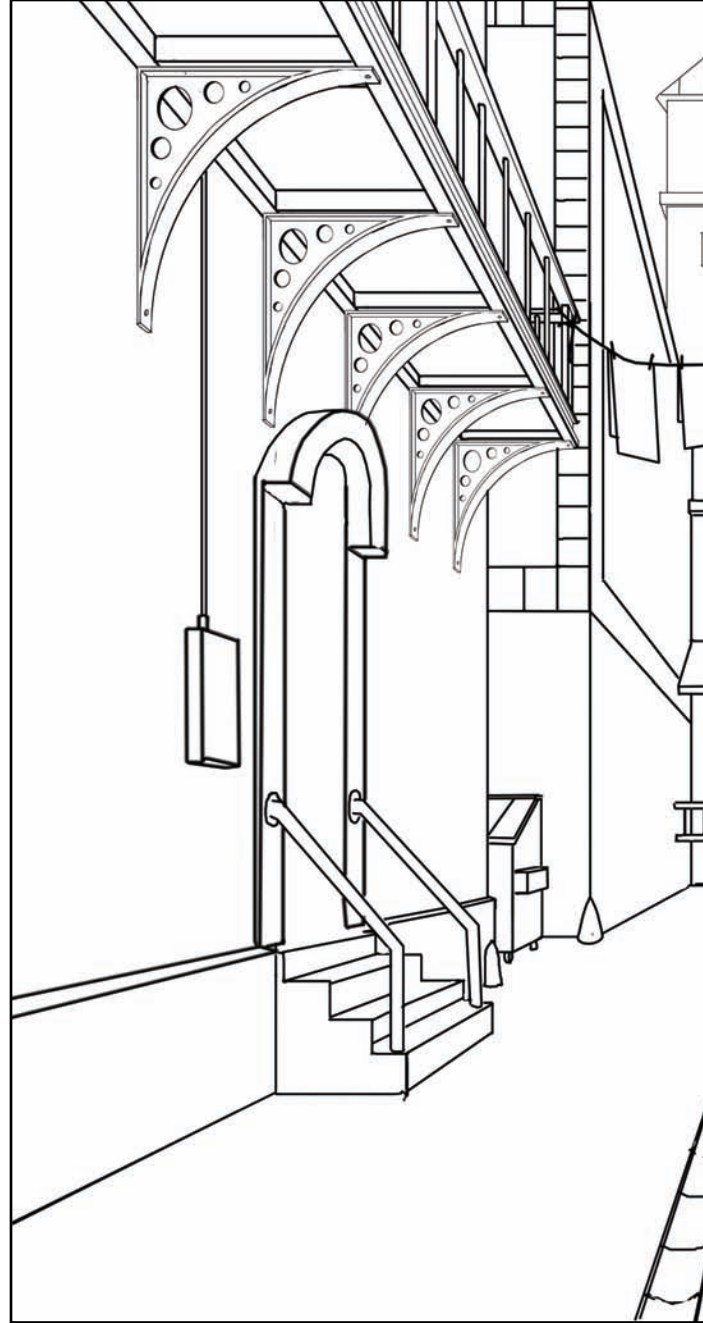



# Values & Vanishing Points

This drawing shows a one-point perspective composition with the cat characters just offset from the vanishing point. The line drawing forces your eye to look at the vanishing point because of the convergence of the wall, bakery, and lines, which unfortunately, causes the cats to become a secondary area of interest in the scene.

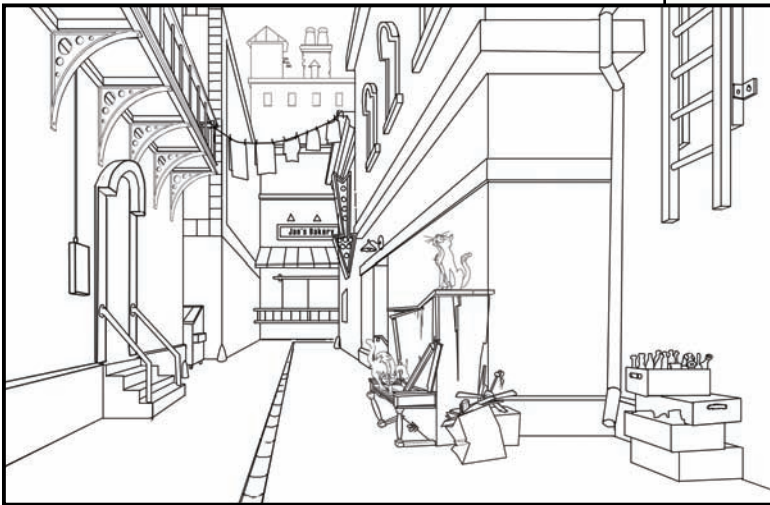
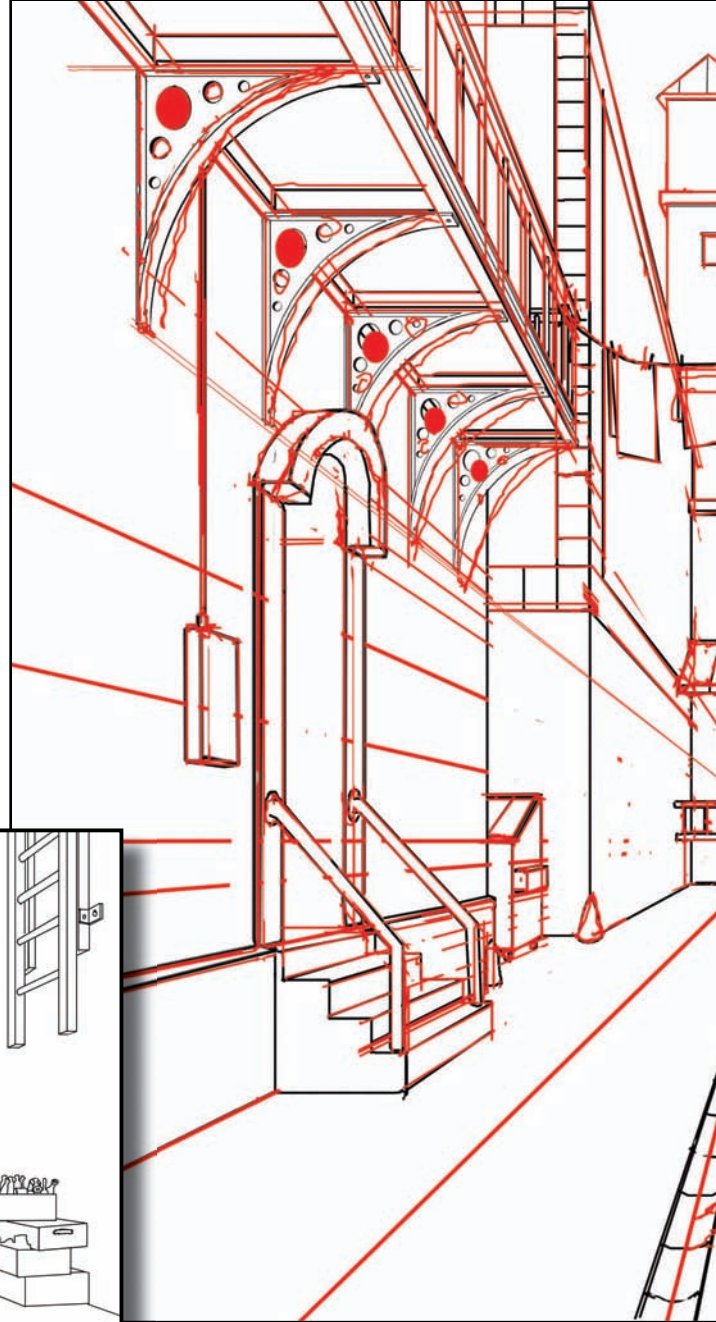

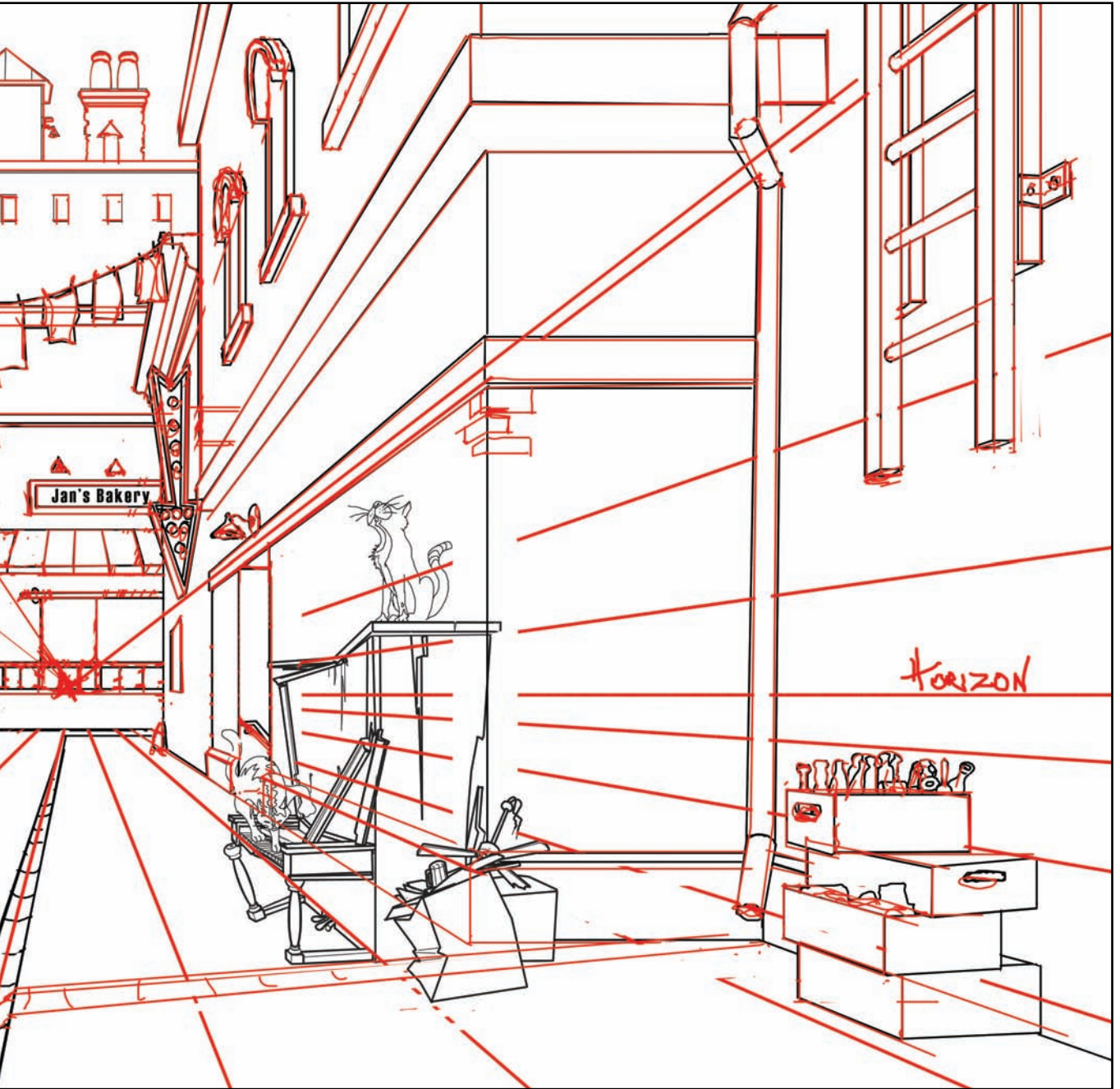

# Values & Vanishing Points

Here I've added values to the design (which shows what the lighting scheme will be). The addition of these values solves the problem of the vanishing point upstaging the cat characters. With the portion of the drawing containing the vanishing point darkened, the cats are now shown in the lightest area and become the dominant focal point on the stage.

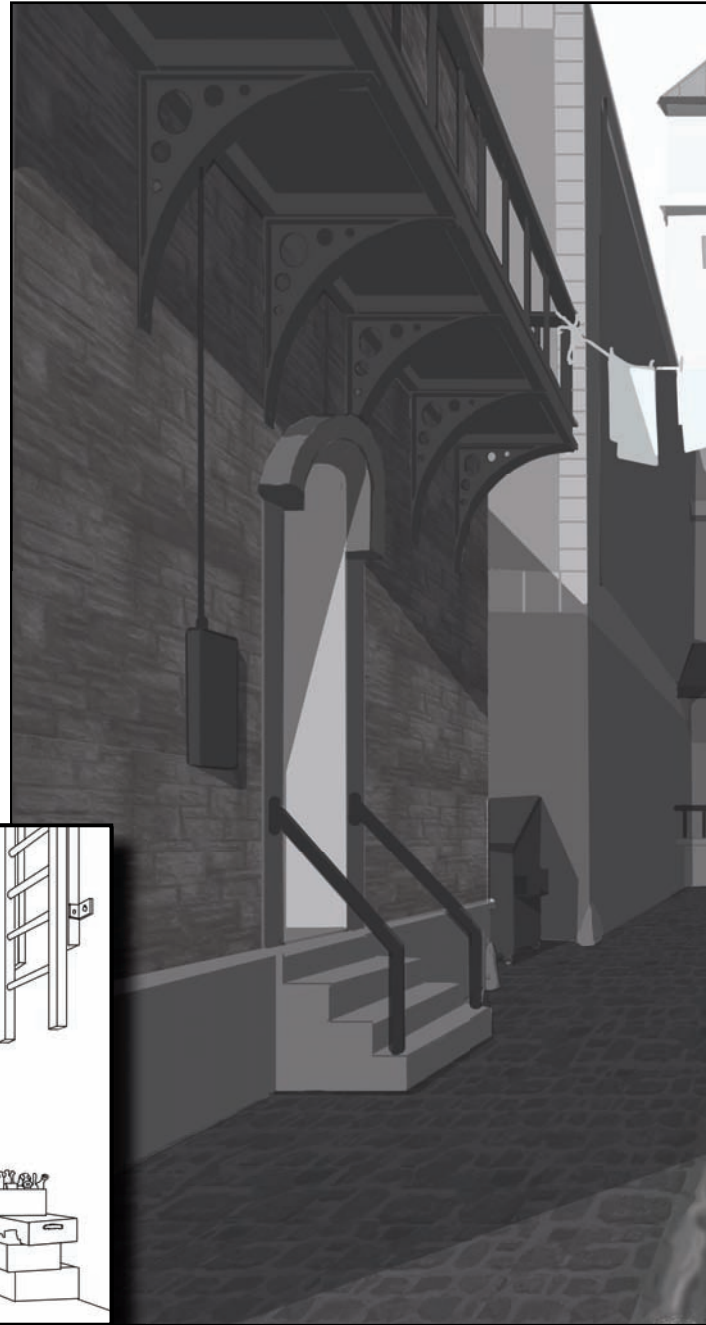
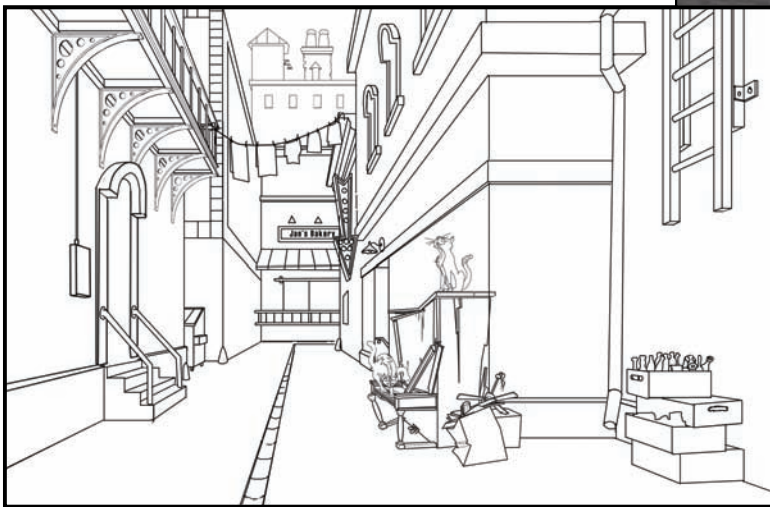



**W**hat would you do if your story described a camera move that followed a character around a room running in circles or looking up at a tree as a leaf falls from the top as the camera follows it to the ground? How would you set up your perspective?

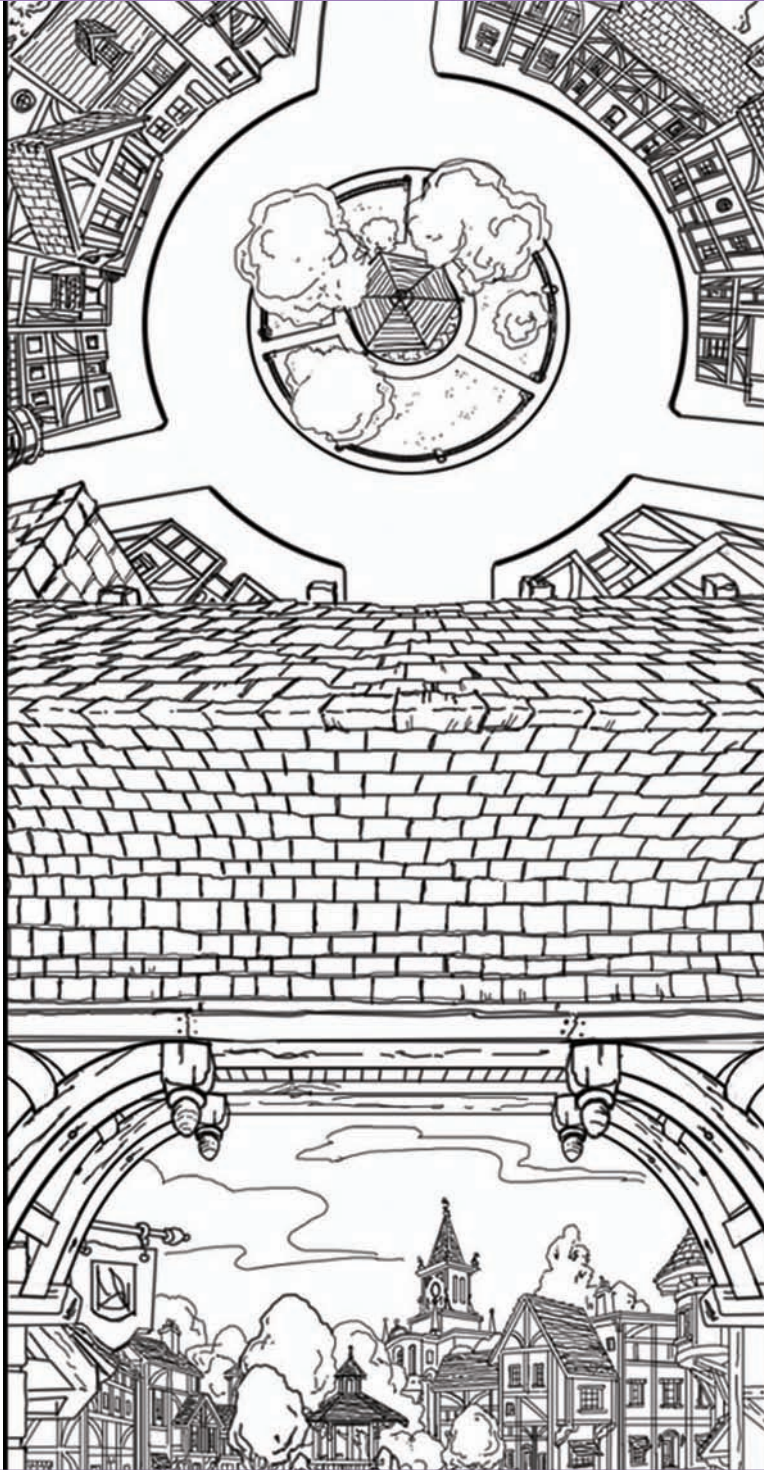



# T ricks

## Curved Pans

There will be times when it's necessary to have a curved pan background moving from a one-point perspective to another one-point. The trick of this shot is to separate the vanishing points so it's a gradual curve of the perspective, and that you don't have the two perspectives in one field of view at the same time.

If you follow a character or object in the scene, the animation can be used as a distraction to hide the perspective change if it moves toward the camera filling the field or close to it, and then moves away from camera into the background.



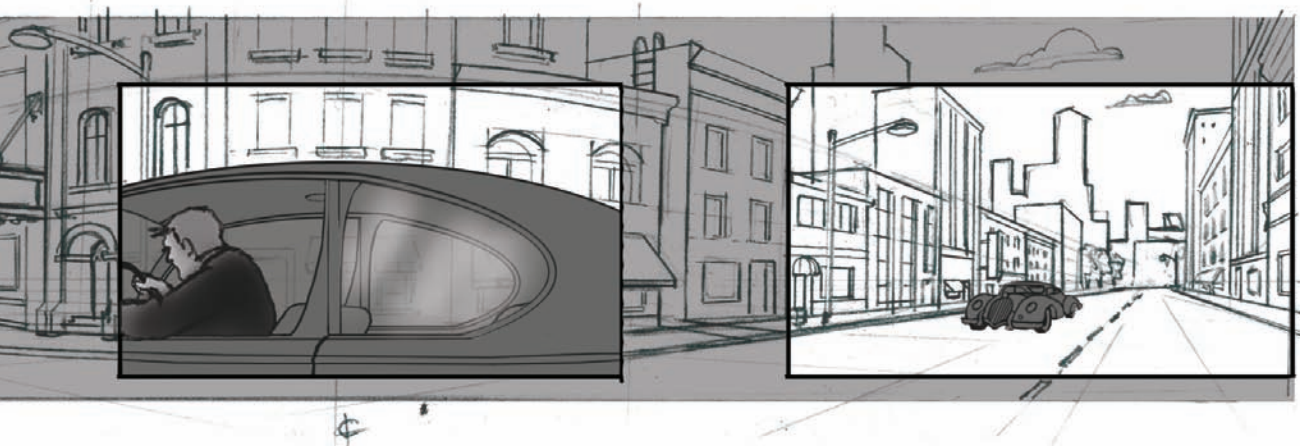

# Tricks

## A New Angle

A trick to pan from a down shot to an up shot is to plan the perspective on a horizontal level plane (example 1). Then take the rough, and put it on an angle (tilt horizon). This will make for a simple camera move and the animation will be animated in the normal configuration on bottom pegs. When camera crosses the horizon you get a natural perspective change (example 2).

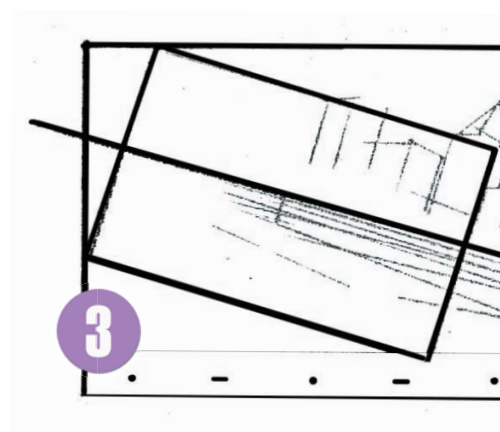
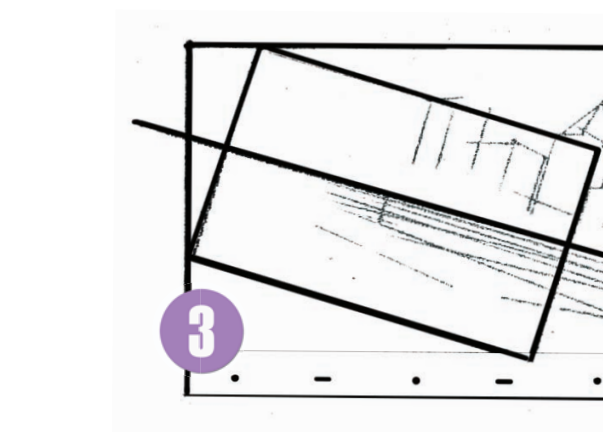
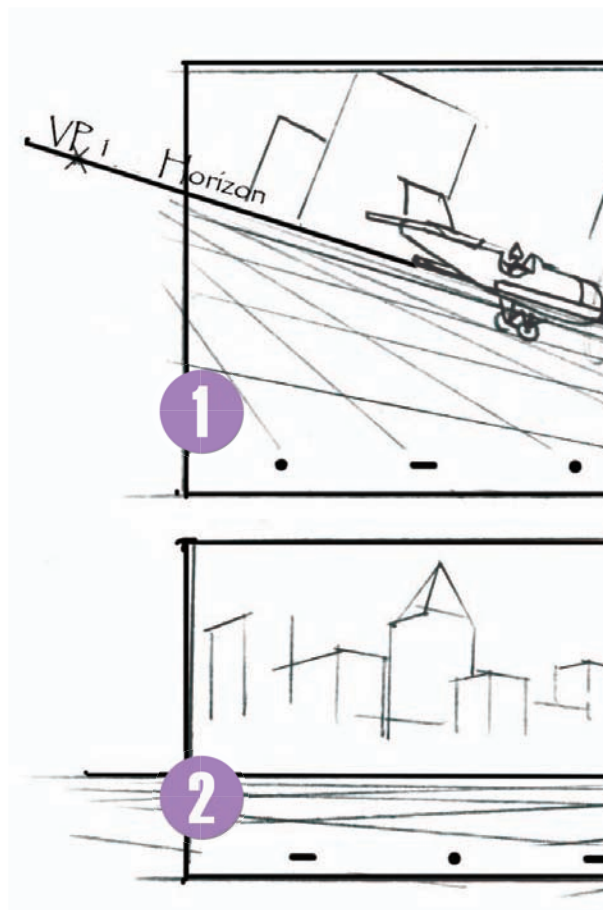

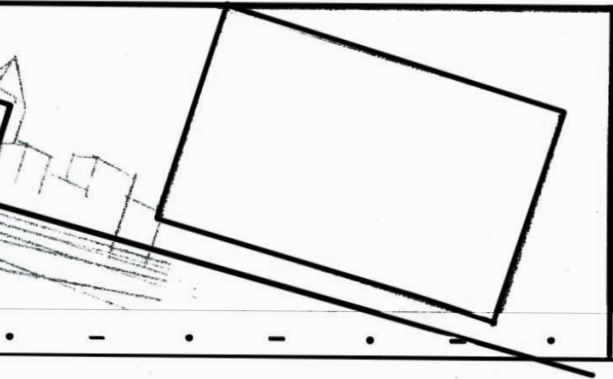
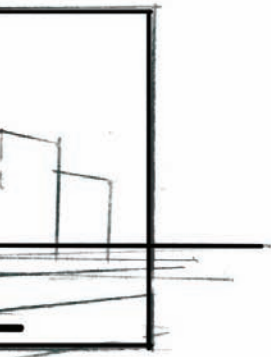
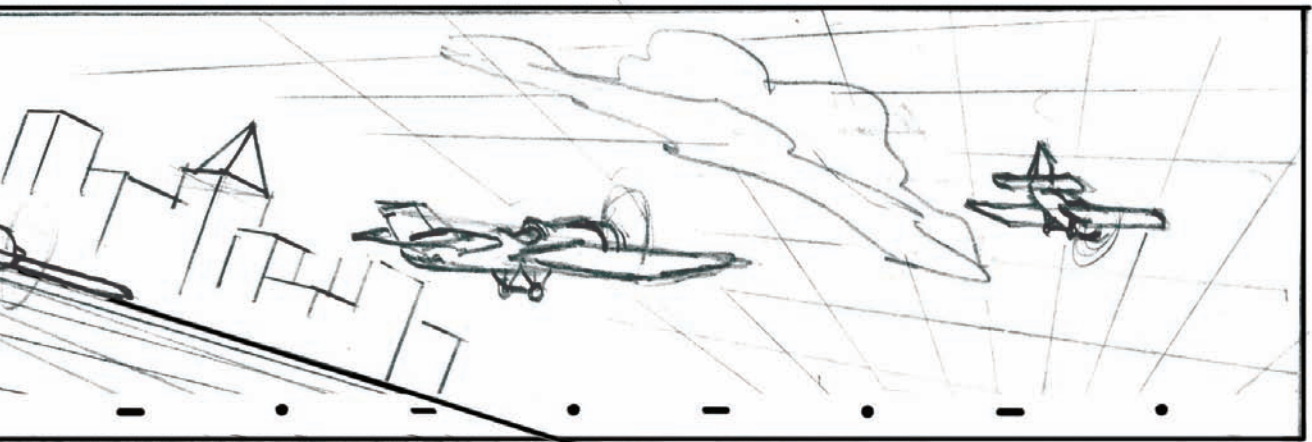

Place field on tilt so that the horizon is parallel to the picture plane, field (example 3).

# Tricks

## If at First You Don't Succeed...Cheat

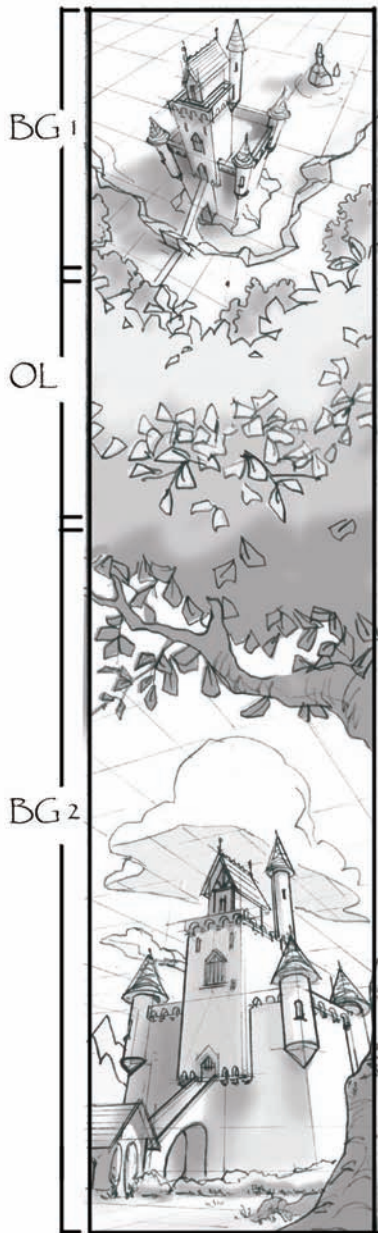

This layout represents a way of changing perspective by hiding the change with an overlay.

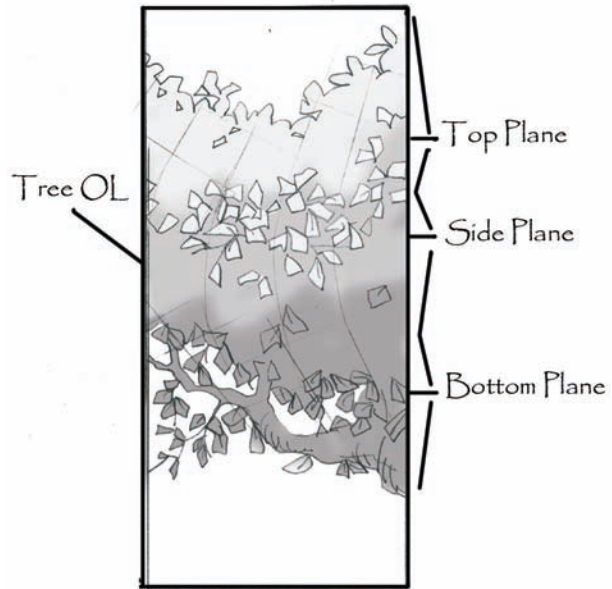

This method of “cheating” the perspective change is very similar to a magician’s sleight-of-hand trick, where you distract the audience by moving

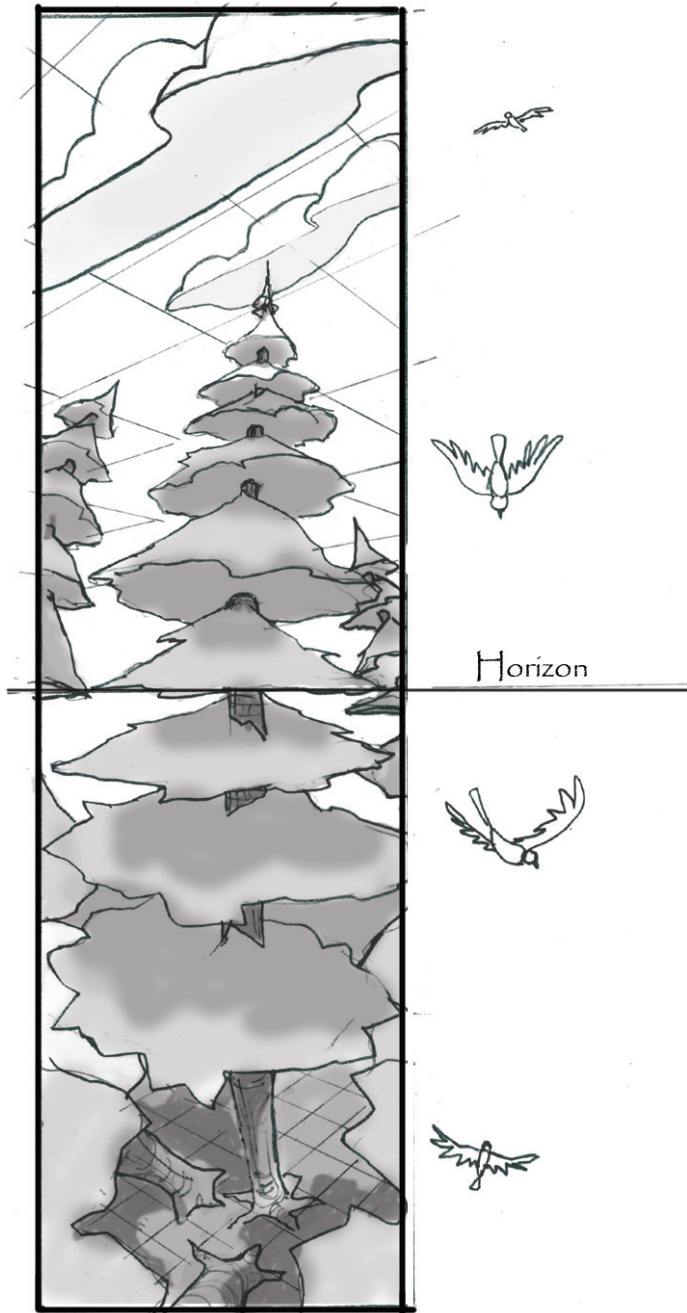

something in front of them to get their attention while you're hiding the card or coin in your pocket. In animation by changing the background you accomplish the same thing. Using two separate backgrounds that are changed one for the other while the overlay fills the screen will give you the illusion of a perspective change.

With these tricks it's very important to know the timing of the scene. You'll have to adjust the artwork to match the speed of the scene.

There's always been controversy with the term "cheat." Some use the term to discount their lack of knowledge, and others use the term to correct perspective elements that are drawn in correct perspective but might not look right or pleasing to the eye.

# T ricks

When working in animation it's easy to change perspective on objects that move, but it's much more likely that a perspective mistake or oddity will be seen on backgrounds and still objects, simply because they are on the screen throughout the entire scene.

A "cheat" doesn't mean you disregard all basics and put whatever you

want in a scene in any position. The horizon will always be an anchor point, but there can be multiple vanishing points and horizons depending on how complicated you make the composition. A "cheat" gone wrong is when two vanishing points are too close to one another on the horizon, which will warp the lines closest to the picture plane or, as said

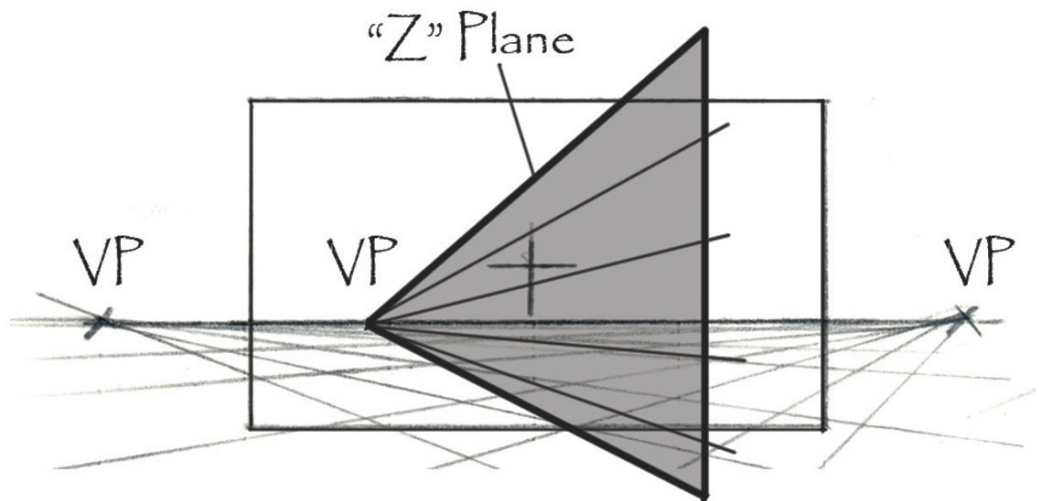

before, placing objects on the horizon. These usually appear in the “Z” plane as it is known in 3-D terms. The “Z” plane starts at the picture plane and vanishes at the horizon. Lines on the “Z” plane are perpendicular to the horizon.

In the 2-D world you can “cheat” the size of objects to create a sense of foreshortening or making objects appear

larger than they really should be to accentuate scale. In live-action and 3-D animation you can use different lenses or focal lengths to accomplish the same thing. When pushing the scale in 2-D animation you will have to give the animator an accurate grid combining the two scale changes.

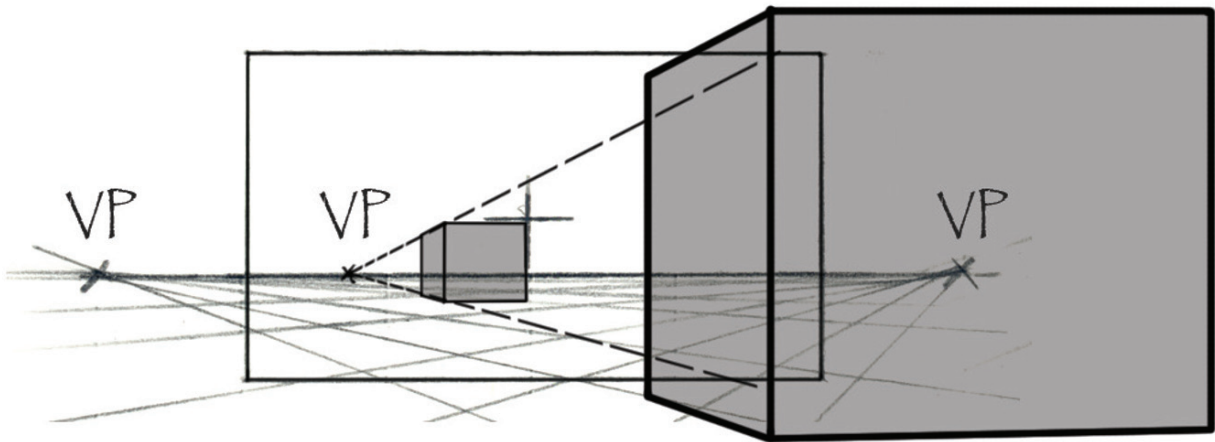



# Chertner's Gallery



Washington D.C. Street  
Disney's  
"Atlantis: The Lost Empire"

© Disney Enterprises, Inc.

