



# Modern Methods in Heterogeneous Catalysis Research



## Photoelectron Spectroscopy



Axel Knop (knop@fhi-berlin.mpg.de)

# Outline

Photoelectron Spectroscopy: General Principle

Surface sensitivity

Instrumentation

Background subtraction

PES peaks, loss features

Peak fitting

Chemical state

Binding energy calibration

High pressure XPS

XPS at the liquid-solid interface

examples

# Problem: What is the (chemical) composition of a surface

## Goal:

### Elemental composition

- Species of atoms on surface
- Concentration of surface atoms
- Vertical distribution
  - on surface (adsorbate)
  - near surface

### Molecular state of adsorbates

### Oxidation state of surface species

- $\text{Me}^0 \rightleftharpoons \text{Me}^{n+}$

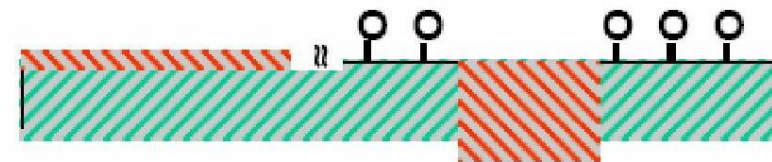
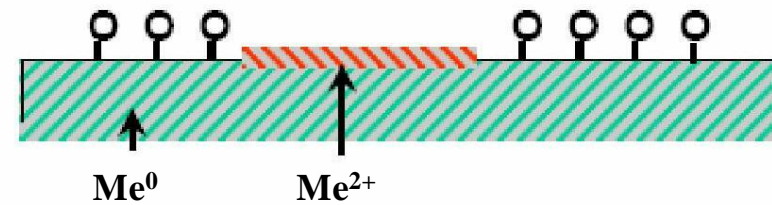
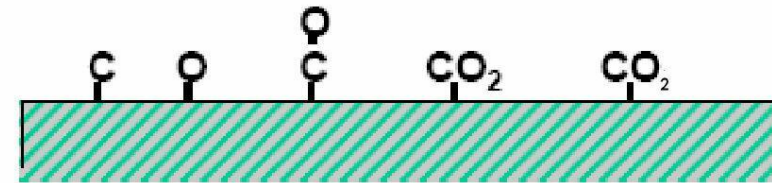

# Photoelectron Spectroscopy: General Principle

principle

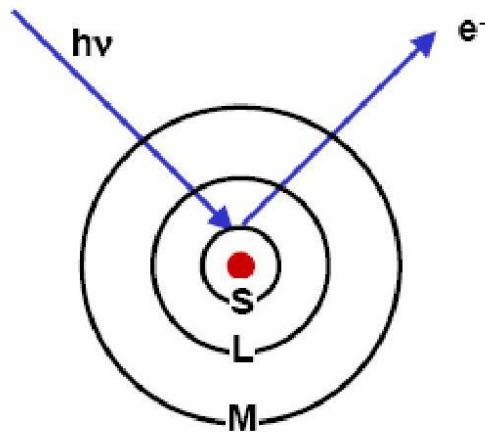

Excitation of Photoelectron

experiment

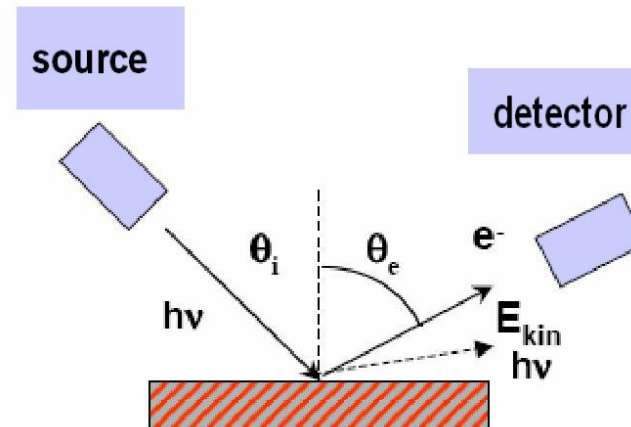

## Excitation

- Mg- $K\alpha$  (1253.4eV)
- Al- $K\alpha$  (1586.6eV)
- Synchrotron radiation (0.1-5keV)

## Detection

- Hemispherical analyzer

# General Principle

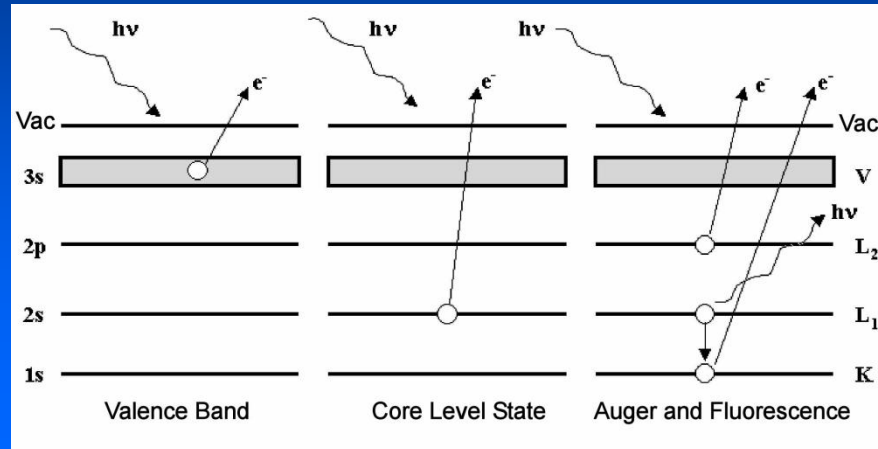

- Detection of photoelectrons from the valence band region and core levels

- Detection of Auger electrons and X-Ray Fluorescence

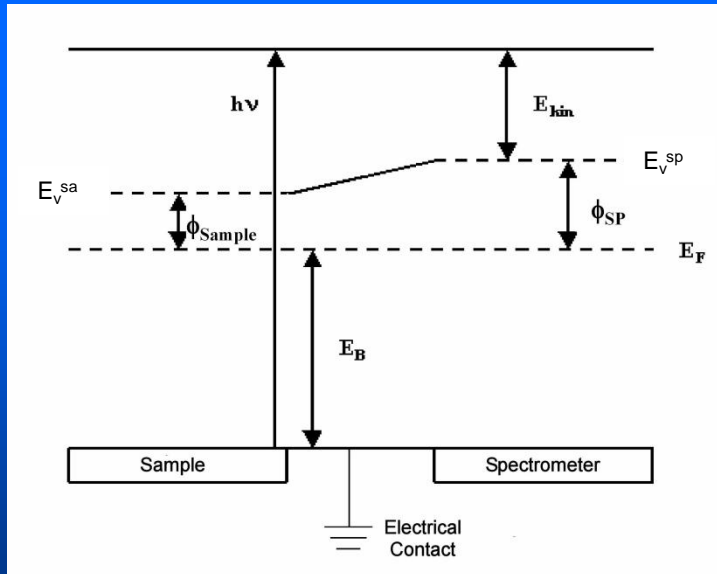

Binding Energy out of:

$$h\nu = E_v^{sp} + E_{kin}$$

$$h\nu = E_{kin} + E_v^{sa} + \Phi_{sp} - \Phi_{sa}$$

$$h\nu = E_{kin} + E_F + \Phi_{sp}$$

# X-ray twin anode

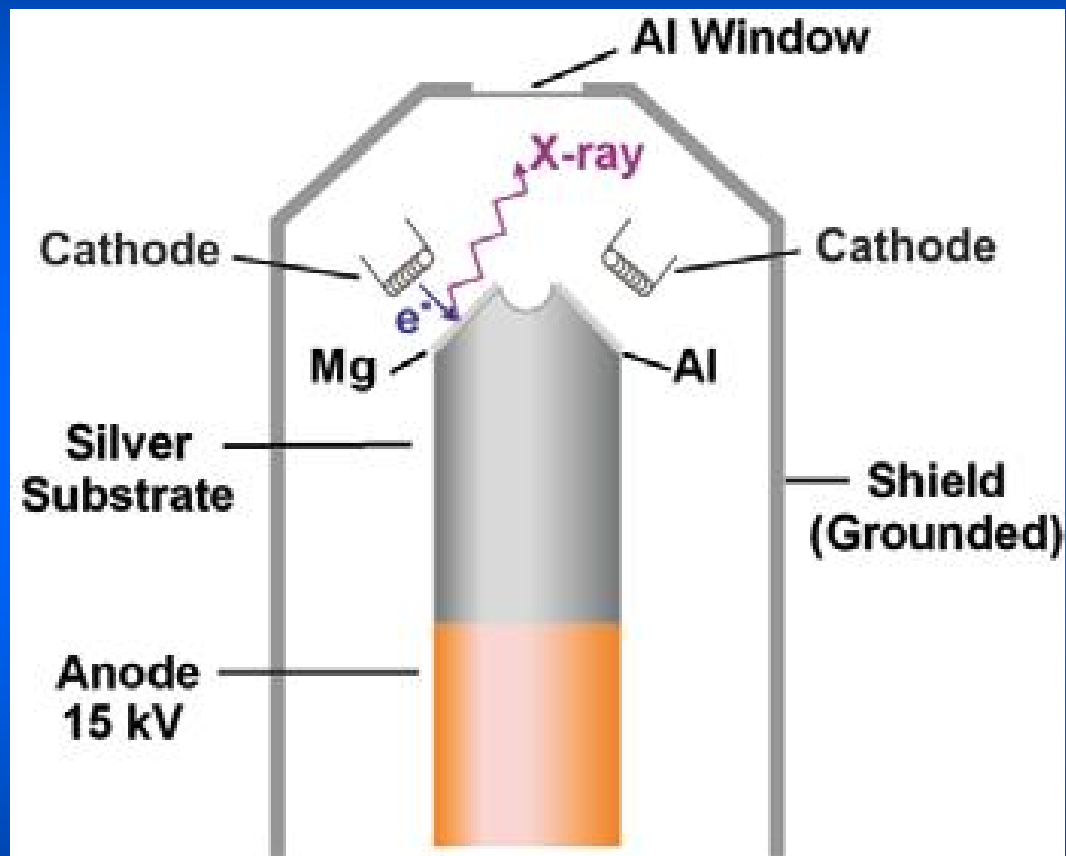

# Parallel plate mirror analyser

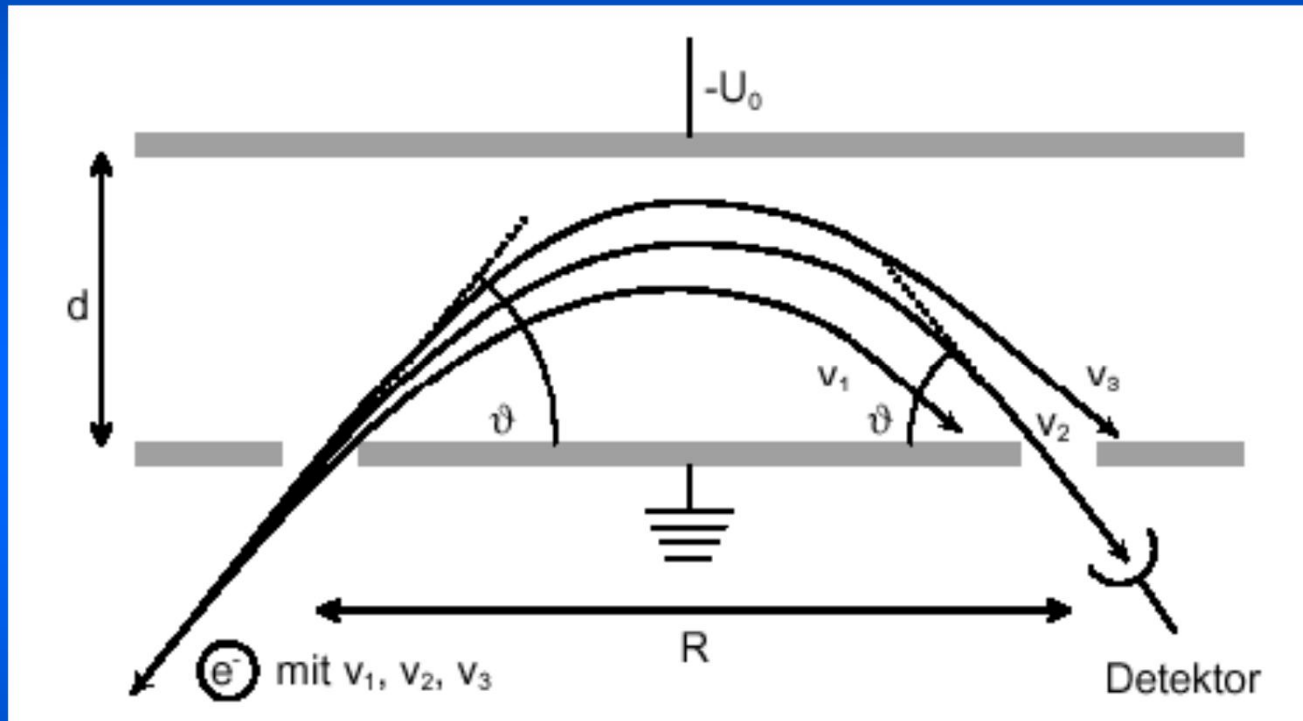

## Halbkugelanalysator

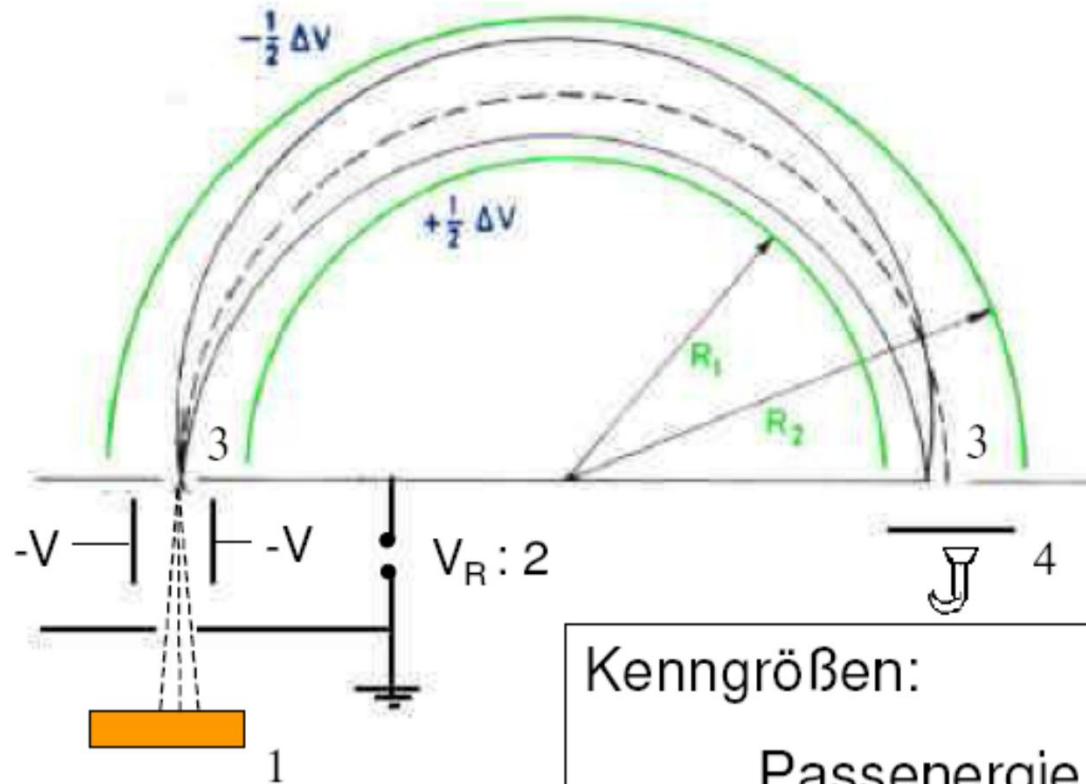

- 1: Probe
- 2: Verzögerungs-  
potential
- 3: Lochblende
- 4: Detektor :  
Channeltron

Kenngrößen:

Passenergie : 5 eV

Winkelakzeptanz : 1°

max. Rate : 30.000 /s



## Halbkugelanalysator

Elektronen werden zunächst auf einen bestimmten Energiebetrag **abgebremst**

Nur Elektronen mit bestimmter "**Passenergie**" können den Detektor erreichen

Je kleiner die "Passenergie" desto besser die Energieauflösung

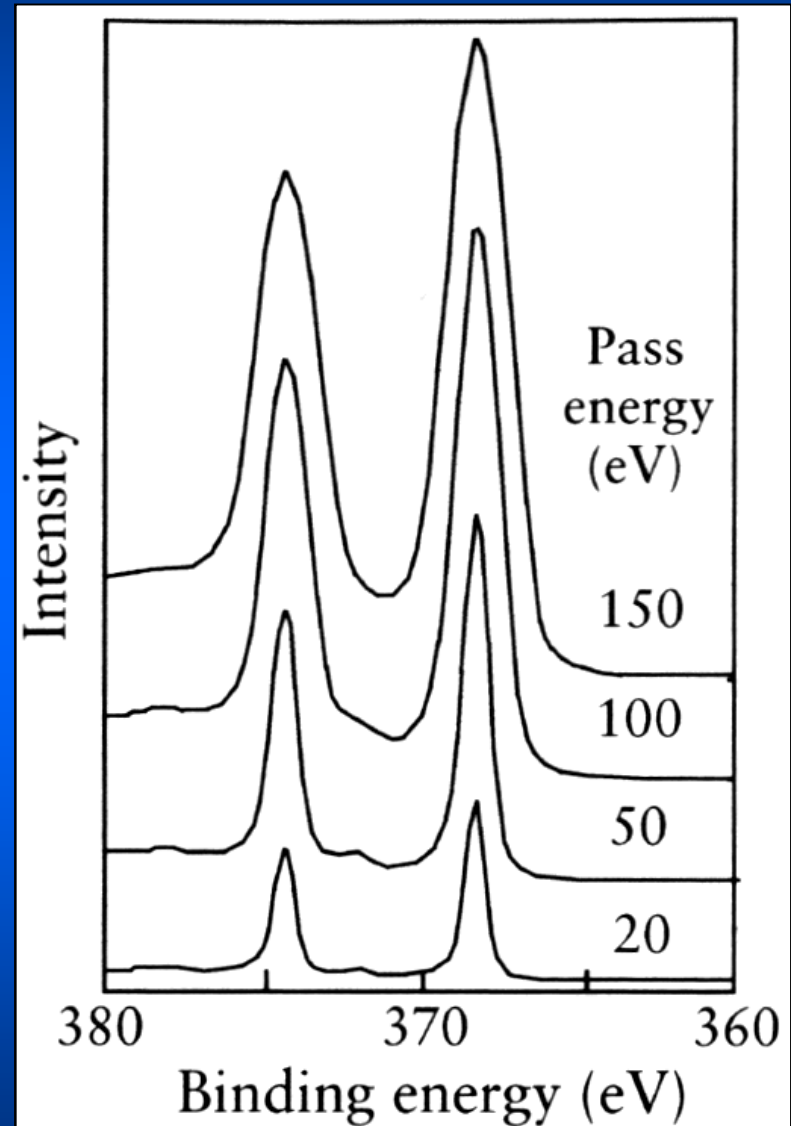

# Detector: Channeltron

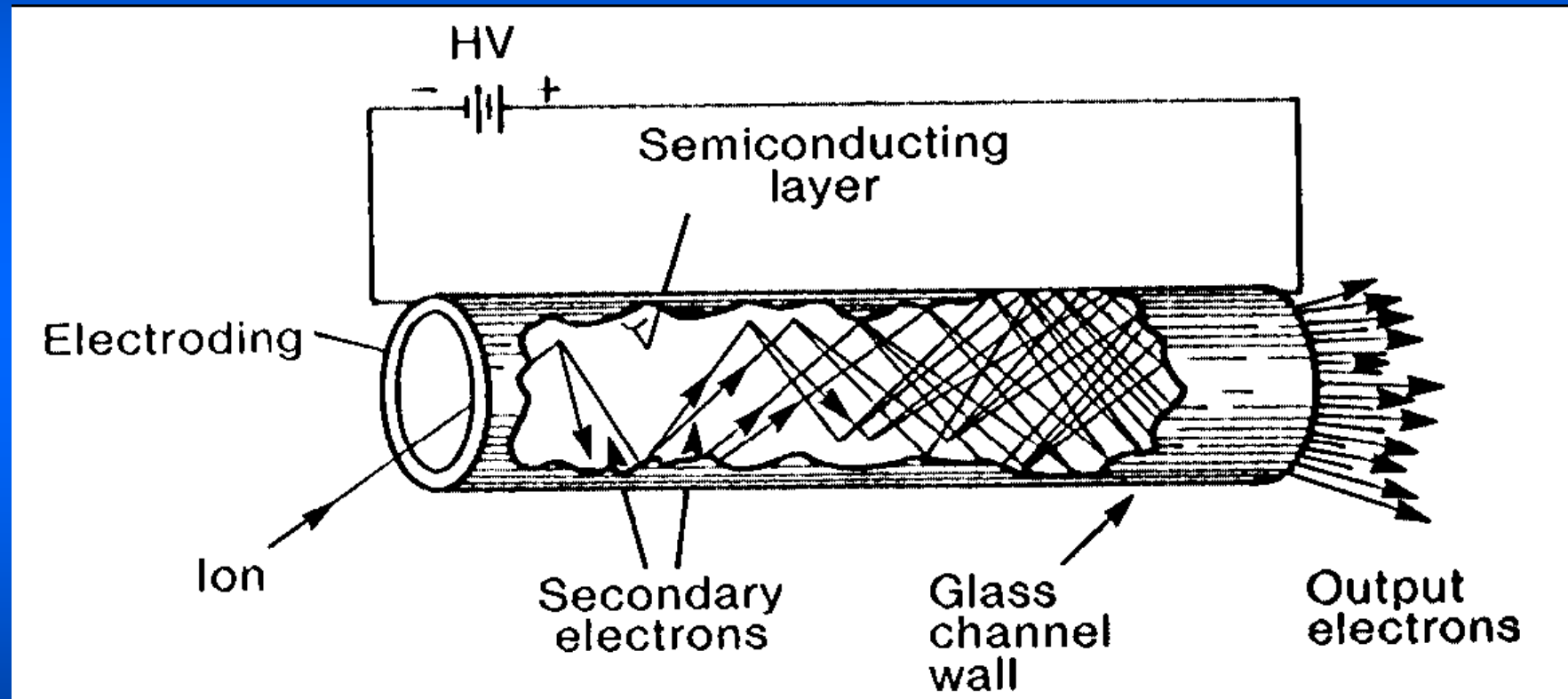

# XP spectra: two different anode materials

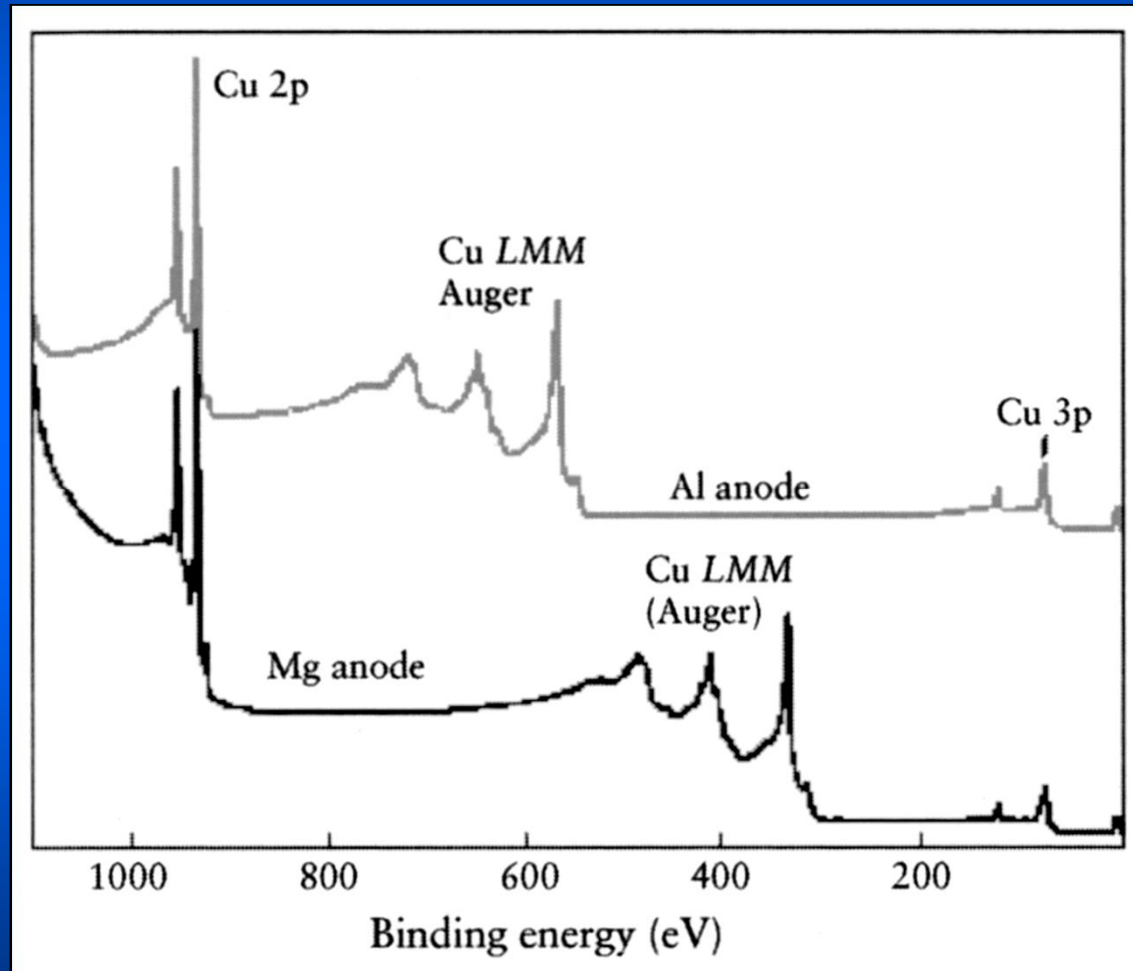

# Where do the electrons come from?

**Distance electron can travel in solids depends on:**

- Material
- Electron kinetic energy

à Measure attenuation of electrons by covering surface with known thickness of element

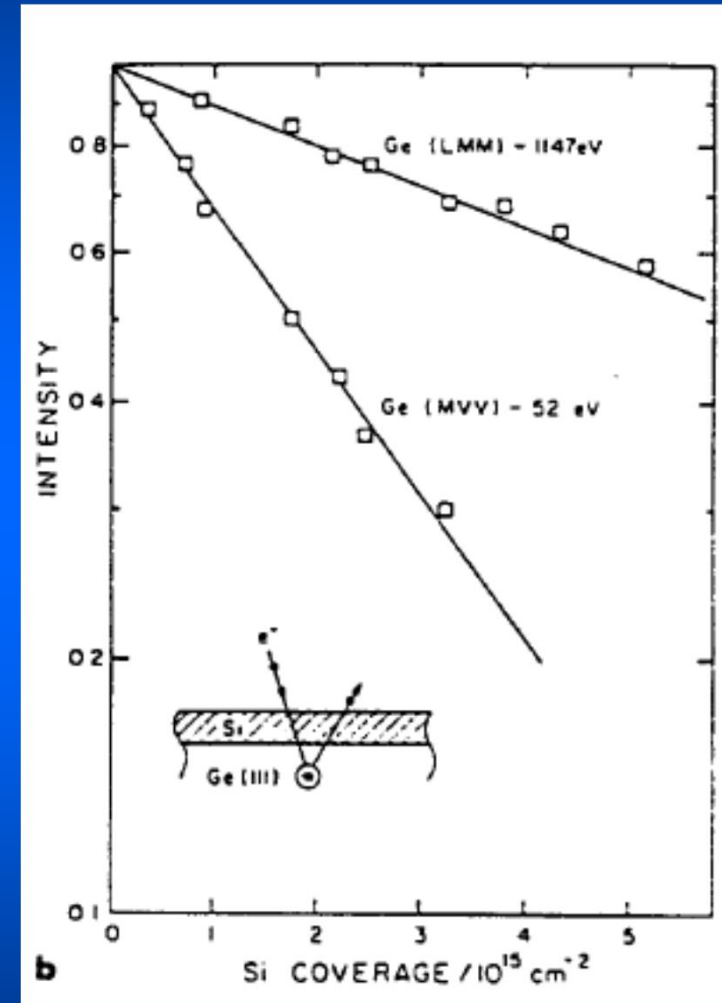

# Sampling Depth

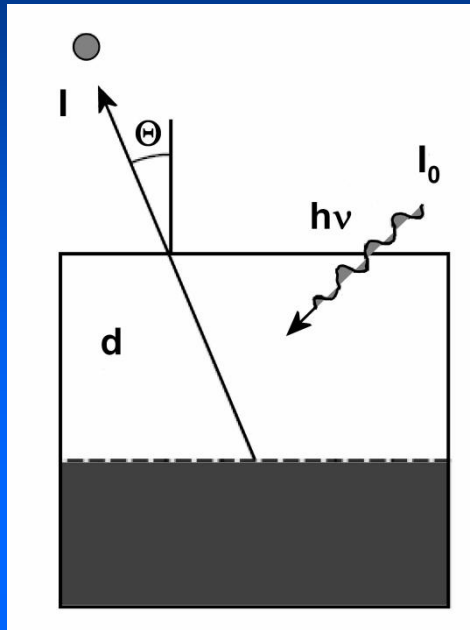

Disregarding elastic scattering:

$$I = I_0 \exp\left(\frac{-d}{\lambda \cos \theta}\right)$$

$$\ln\left(\frac{I}{I_0}\right) = \frac{-d}{\lambda \cos \theta}$$

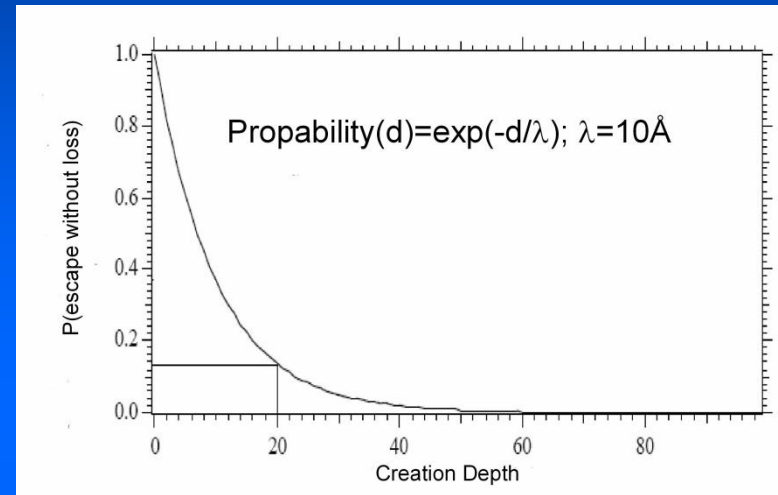

## Sampling depth:

For normal takeoff angle,  $\cos Q=1$ :

- When  $d=l$  :  $-\ln(I/I_0)=0.367$ , i.e. 63.3% from within  $l$
- When  $d=2l$  :  $-\ln(I/I_0)=0.136$ , i.e. 86.4% from within  $2l$
- When  $d=3l$  :  $-\ln(I/I_0)=0.050$ , i.e. 95.0% from within  $3l$

# Mean Free Path of Electrons in Solids

- IMFP is average distance between inelastic collisions
- Minimum  $l$  of 5-10Å for KE  $\sim$  50-100 eV
- à Maximum surface sensitivity

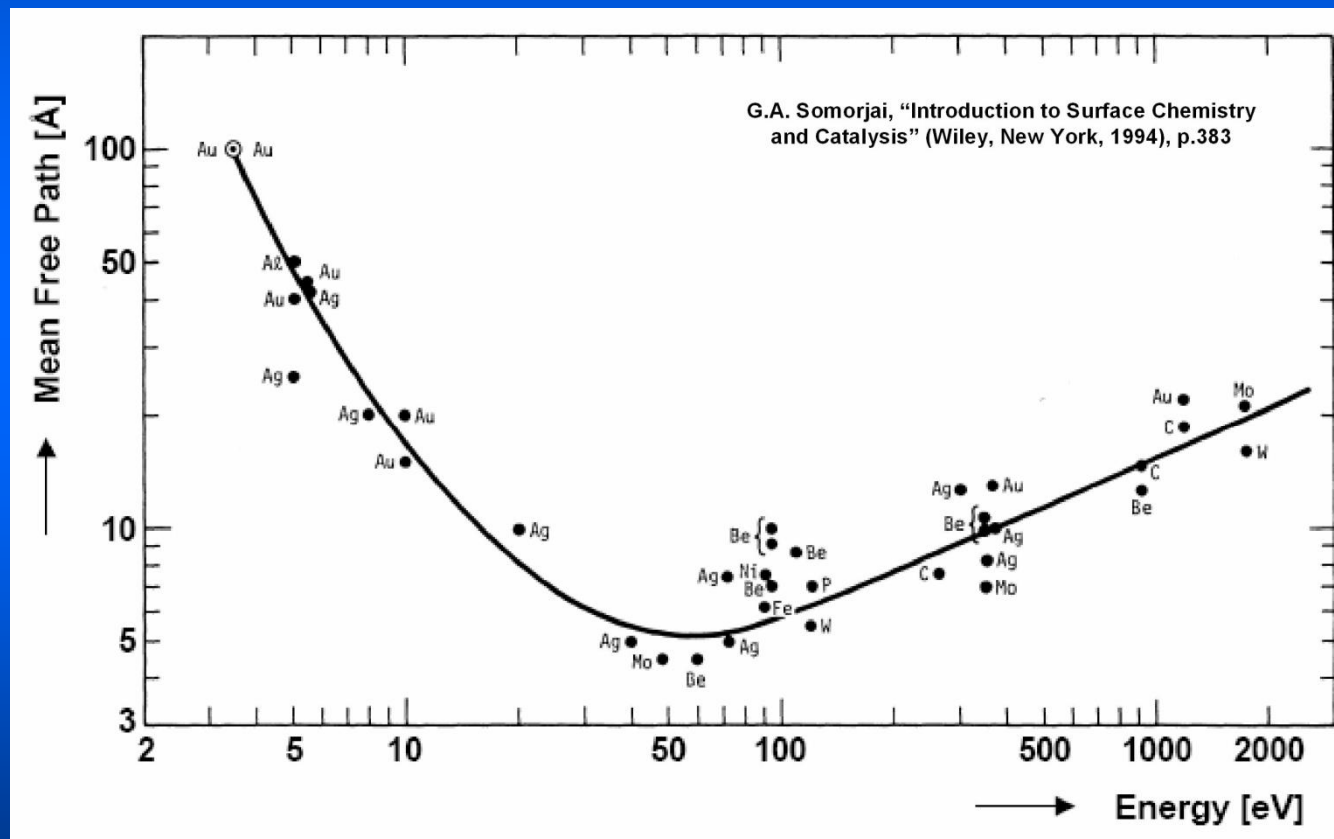

# Origin of background

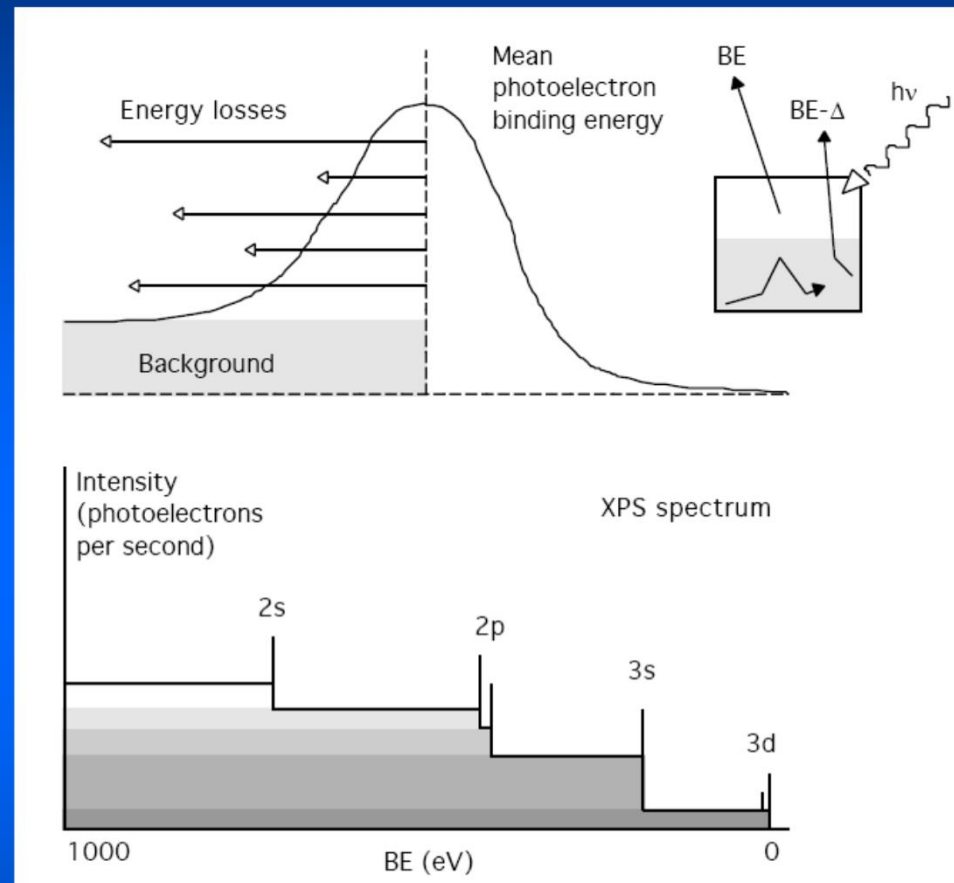

Background of scattered electrons due to limited IMFP  
à Higher for low KE

# Background Correction

## Background subtraction

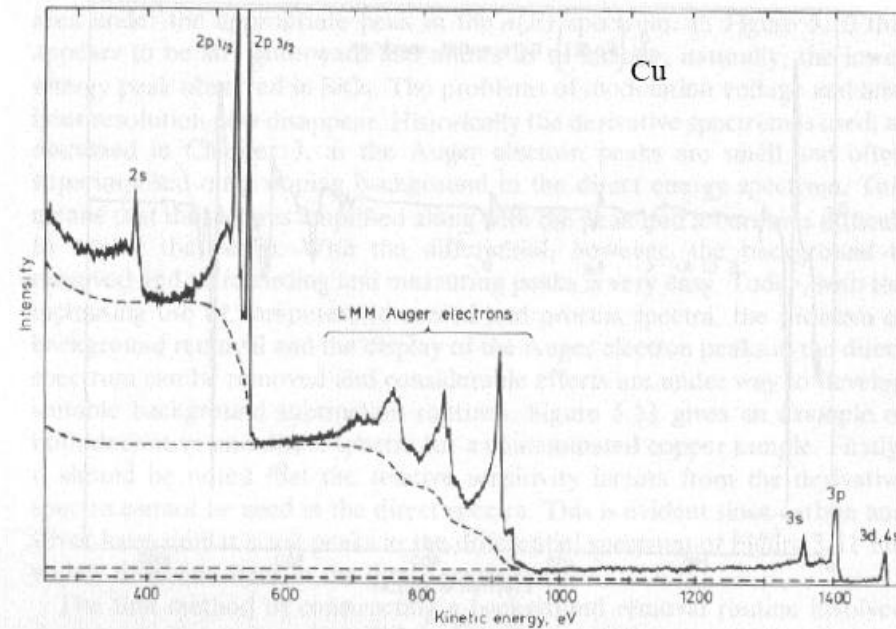

- à Choose suitable energy range for subtraction
- à Baseline on high KE side



# Background Correction

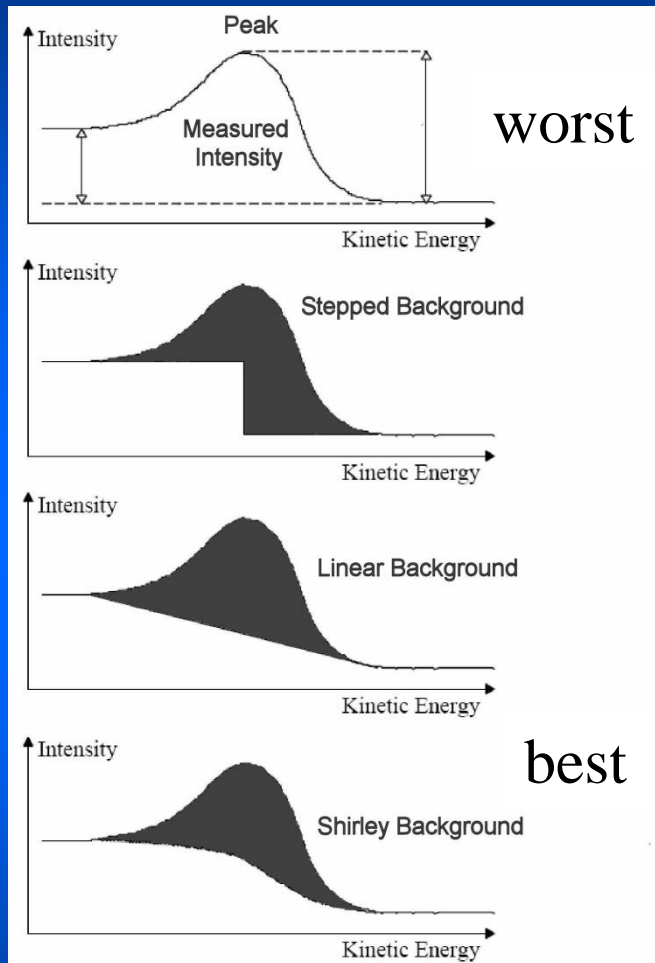

Several ways to subtract background:

- Stepwise
- Linear
- Method of Tougaard

à Most common:

Method of Shirley et al.:

$$b_i = k \sum_{j=i+1}^N p_j$$

**Always use same background subtraction method for all peaks!**

# Spectral features: PE Peaks

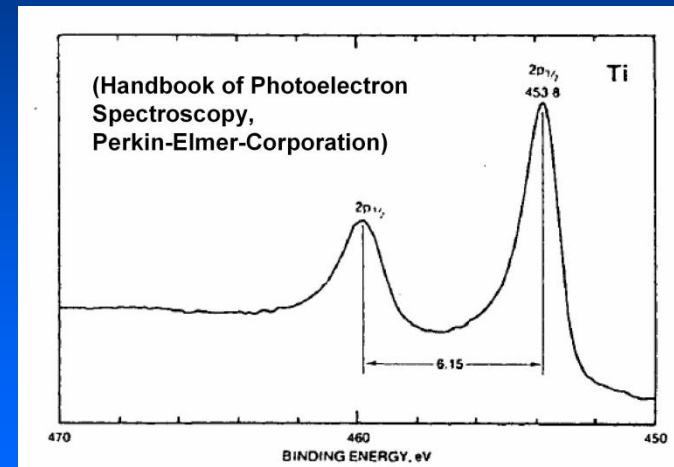
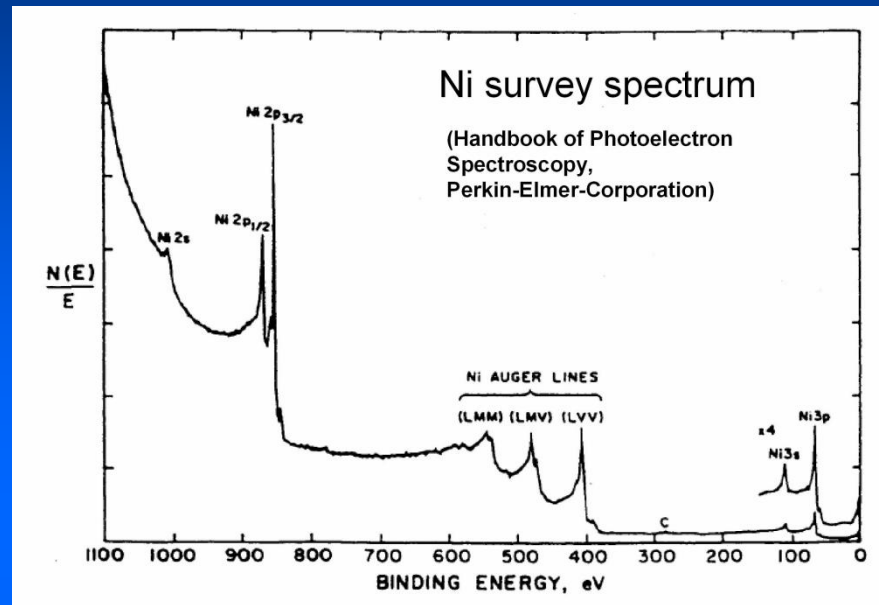

Orbital peaks used to identify different elements in sample

## Observation:

- s orbitals are not spin-orbit splitted à singlet in XPS
- p, d, f.. Orbitals are spin-orbit splitted à doublets in XPS

# Spectral features: PE Peaks

Source: Michigan State University, CEM 924

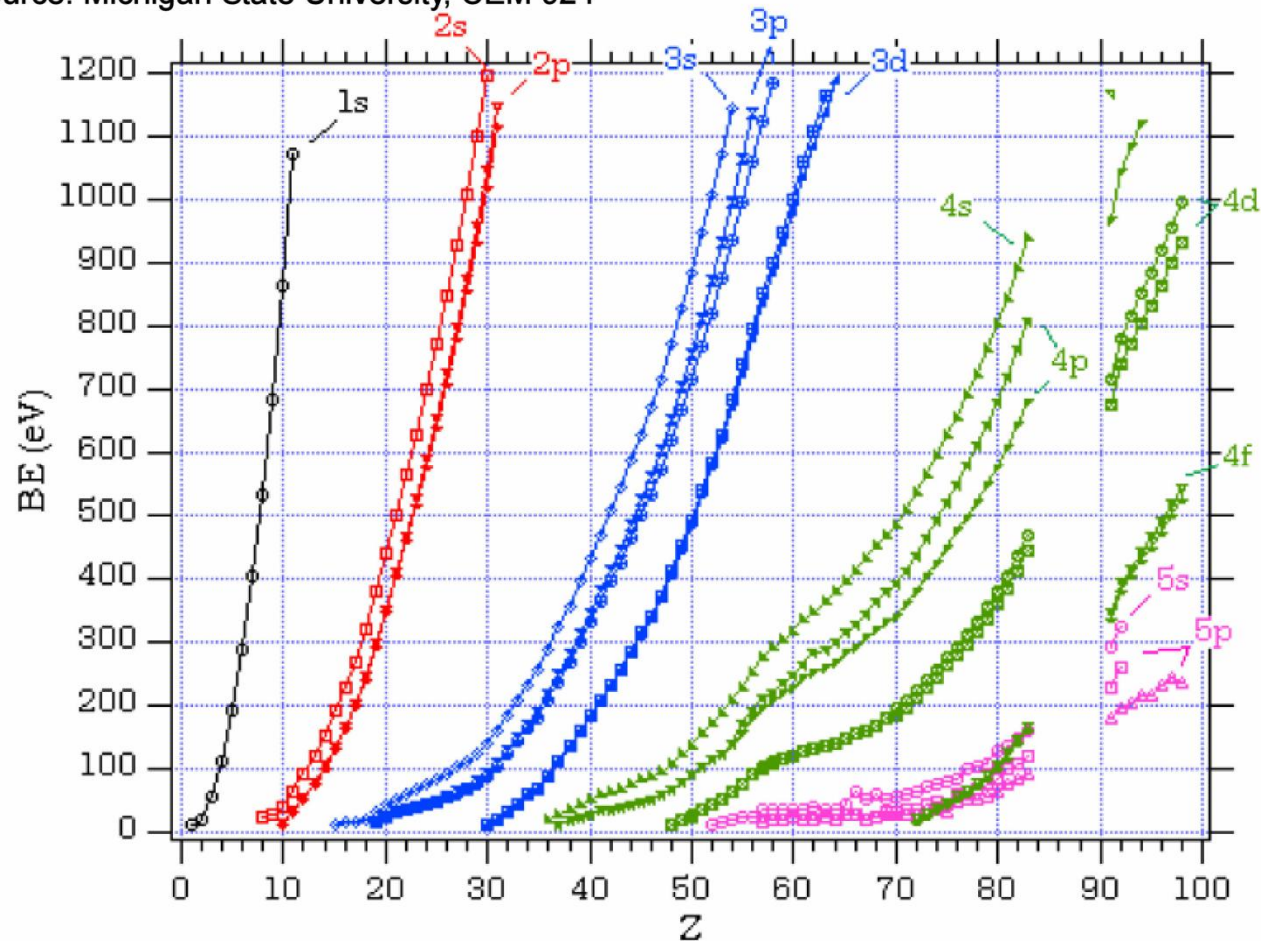

# Spectral features: Auger Peaks

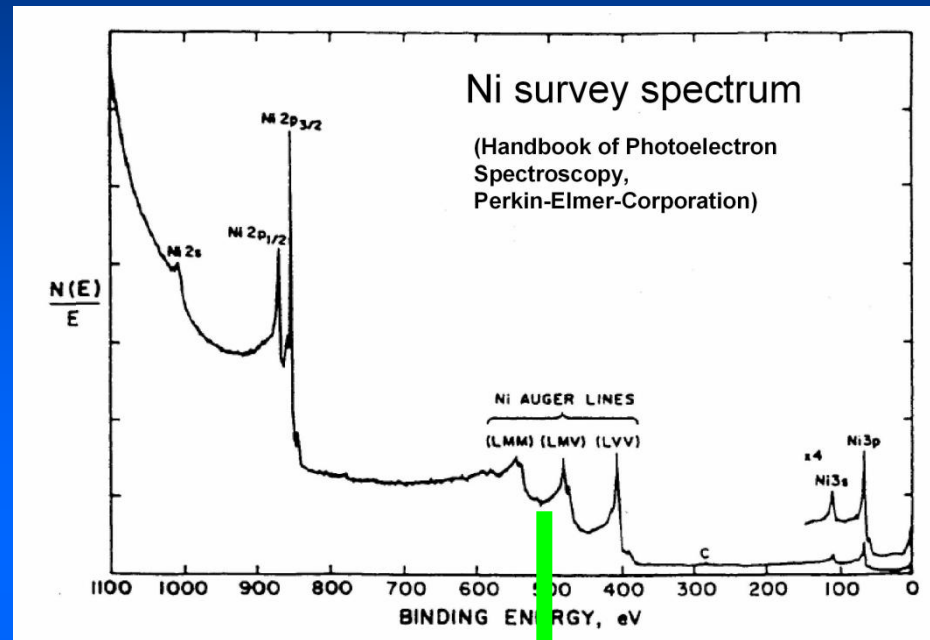

## **Auger peaks:**

Result from excess energy of atom during relaxation (after core hole creation)

- always accompany XPS
- broader and more complex structure than PES peaks

KE energy independent of incident  $h\nu$

# Spectral features: Loss Peaks

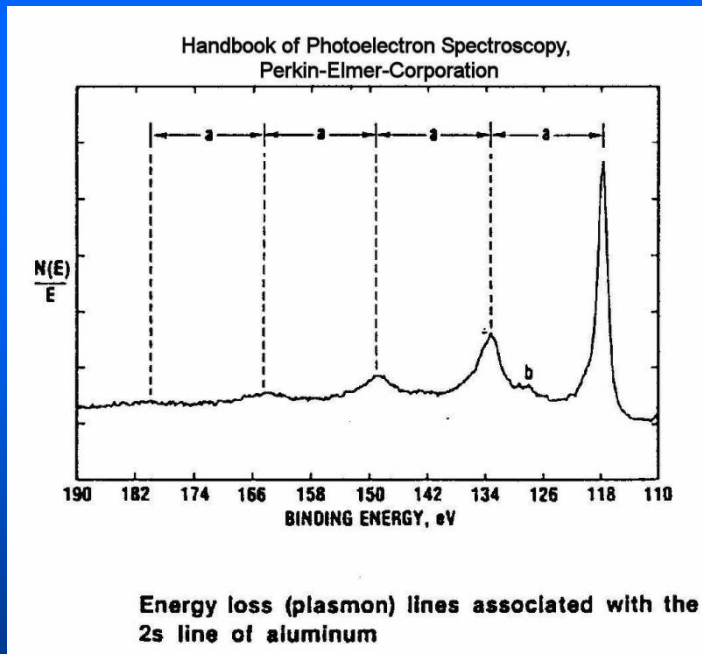
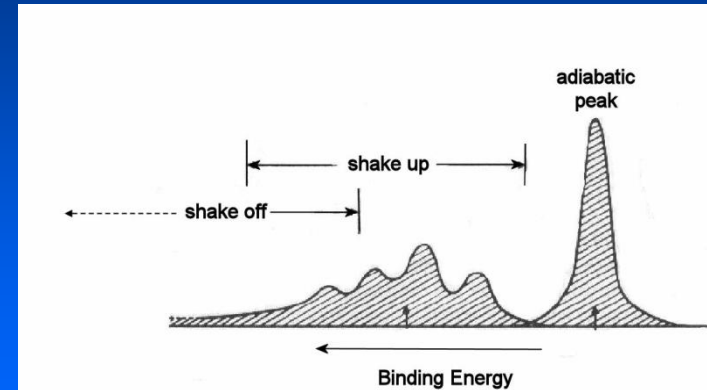
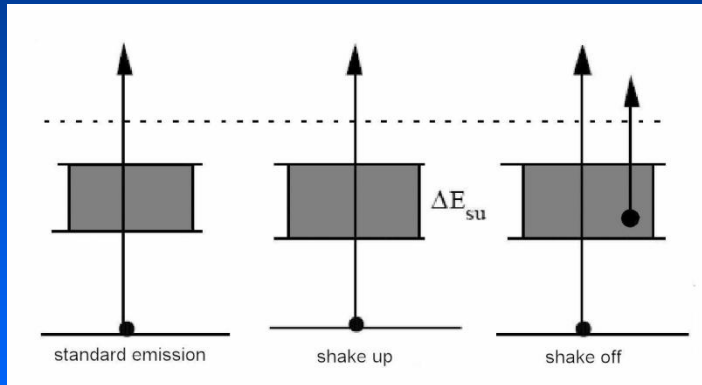

After Emission of PE the remaining electrons rearrange (**Secondary peaks**):

- Relaxation by excitation of valence electron to higher state (**shake up**)
  - à loss of kinetic energy of PE leads to new peaks shifted in BE with respect to main peak
- Relaxation by ionisation of valence electron (**shake off**)
  - à broad shoulder to main peak
- **Plasmon** losses

# Spectral features: Loss Peaks

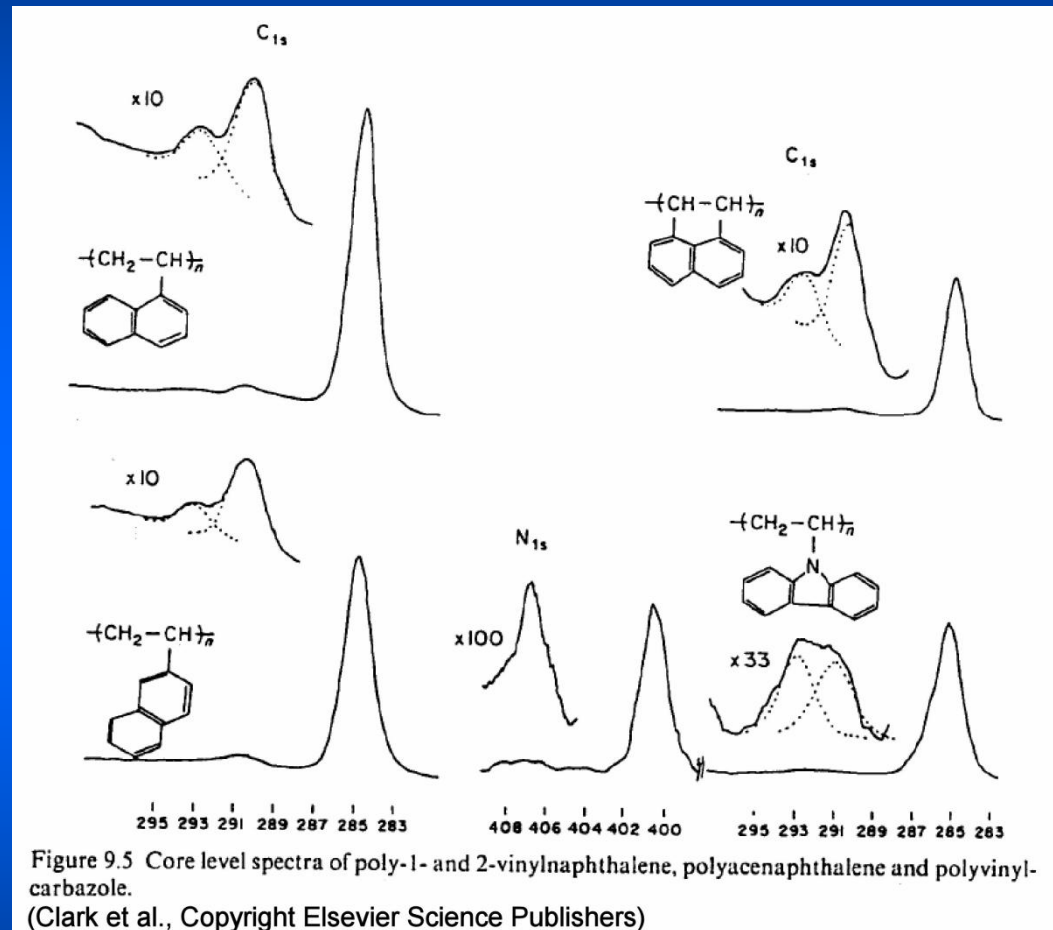

**Loss peaks** can be used to identify chemical composition

**Problem:**  
References needed  
(theoretical or experimental)

# Relationship between the degree of core level asymmetry and the density of states at the Fermi level (BE=0)

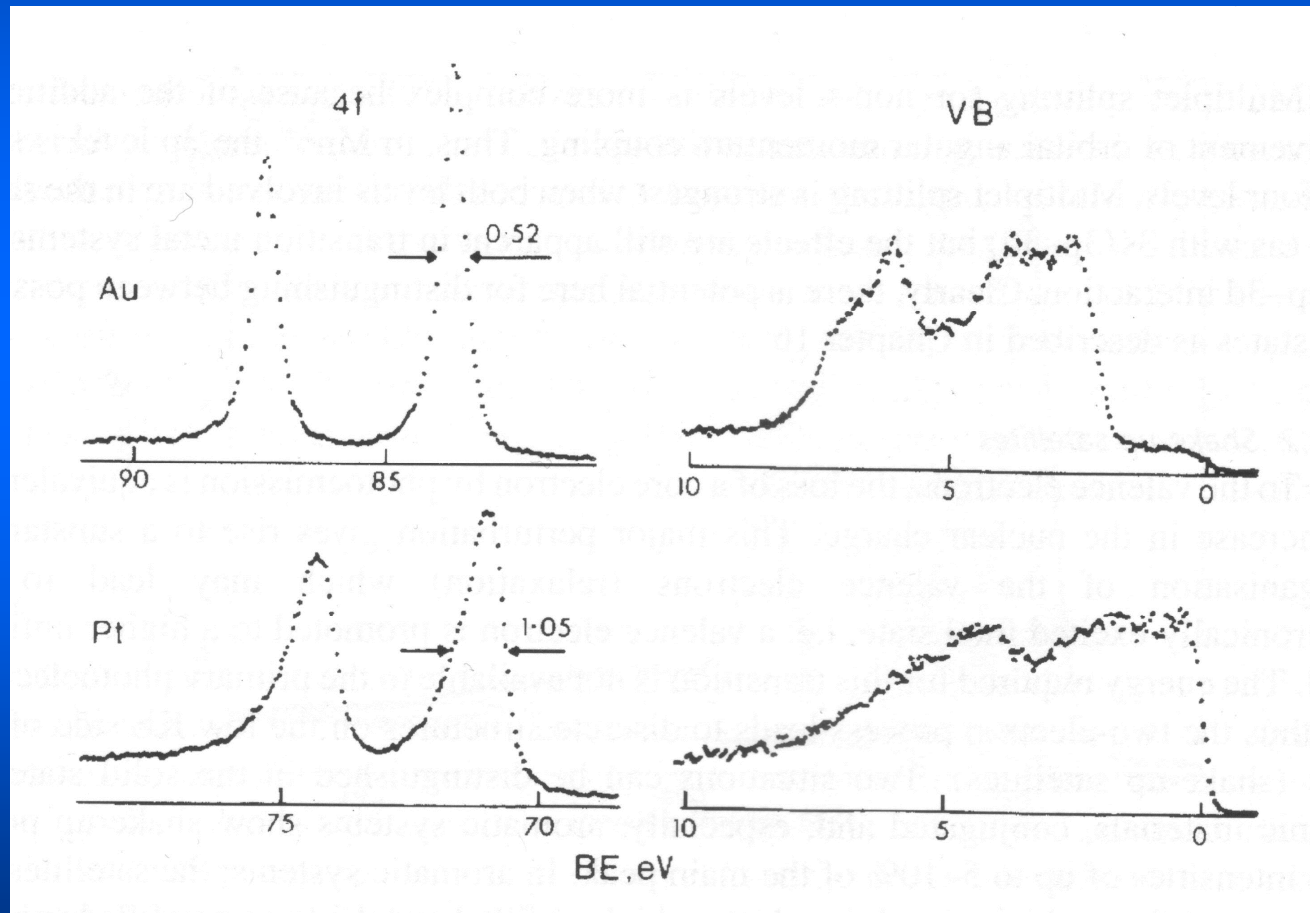



# Analyzing the data: Calibration of Binding Energies

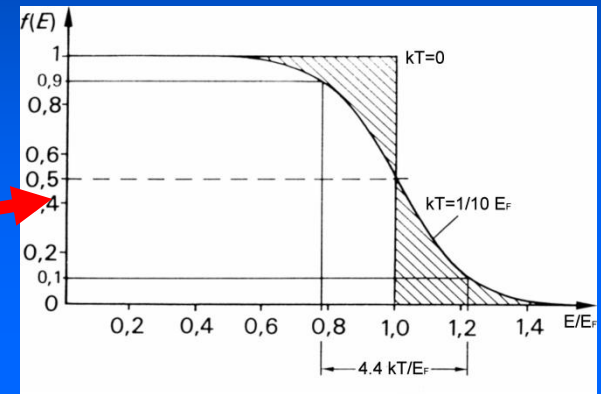
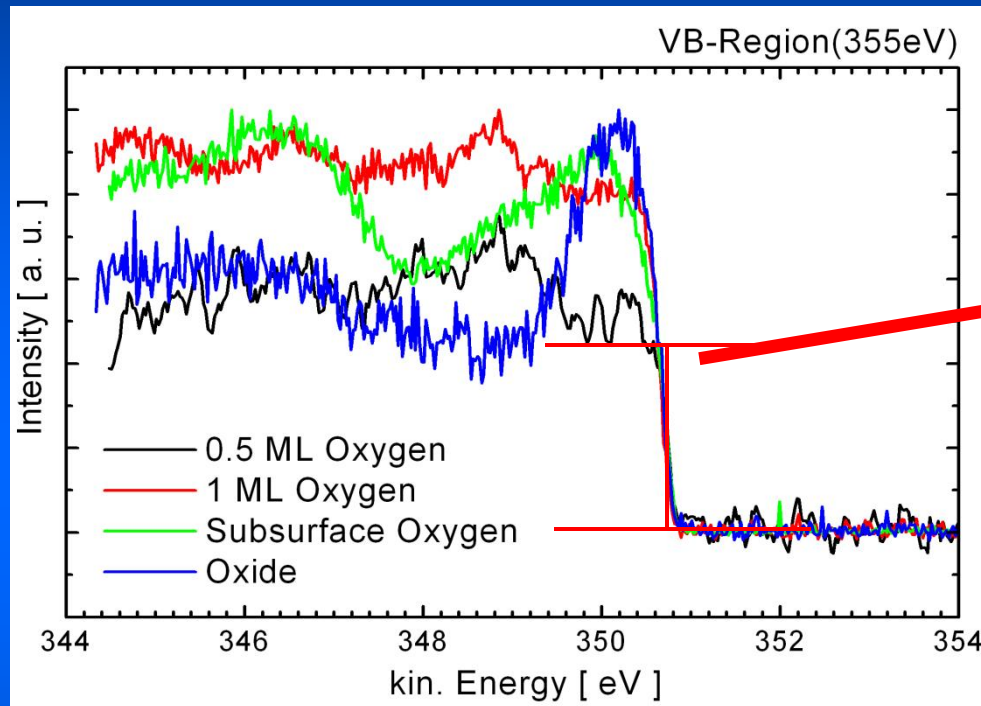

## Identification of FE:

Easy for high density of states near  $E_F$ , but may be ambiguous for samples with low DOS near  $E_F$ , band gap or charged samples



# Line profile modification by charging

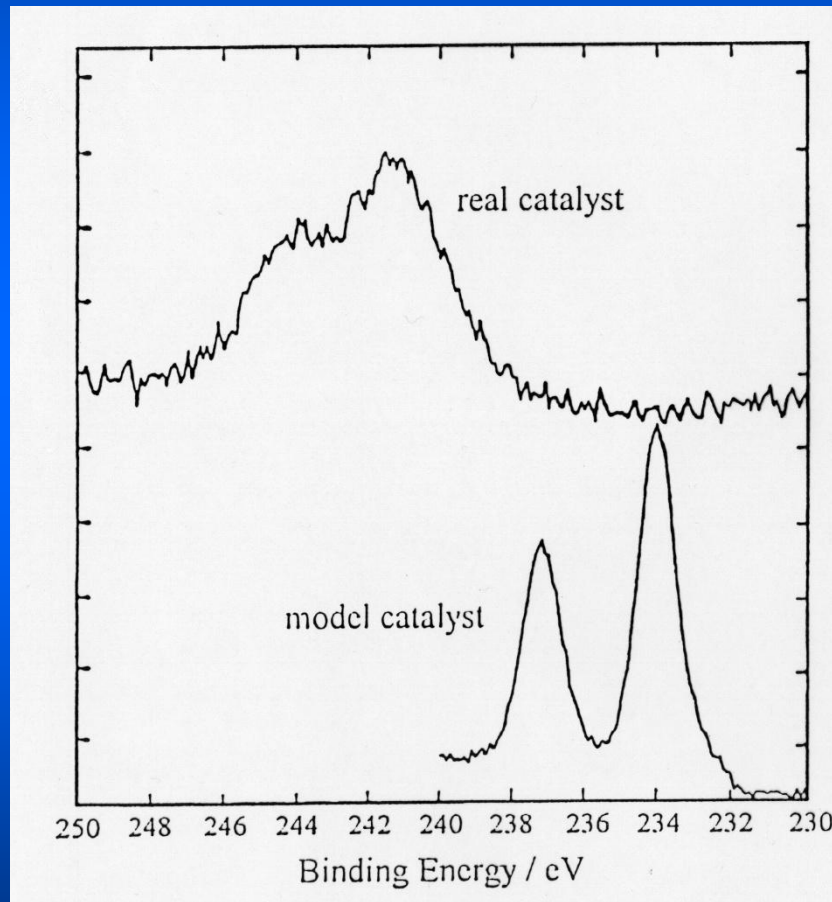

Mo oxide on silica

real catalyst is powder  
sample after impregnation  
and calcination.

# Analyzing the data: Calibration of Binding Energies

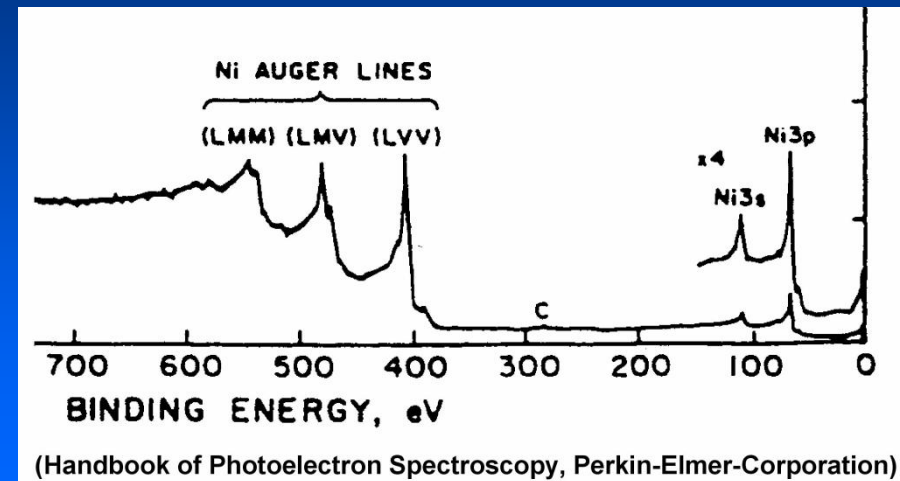
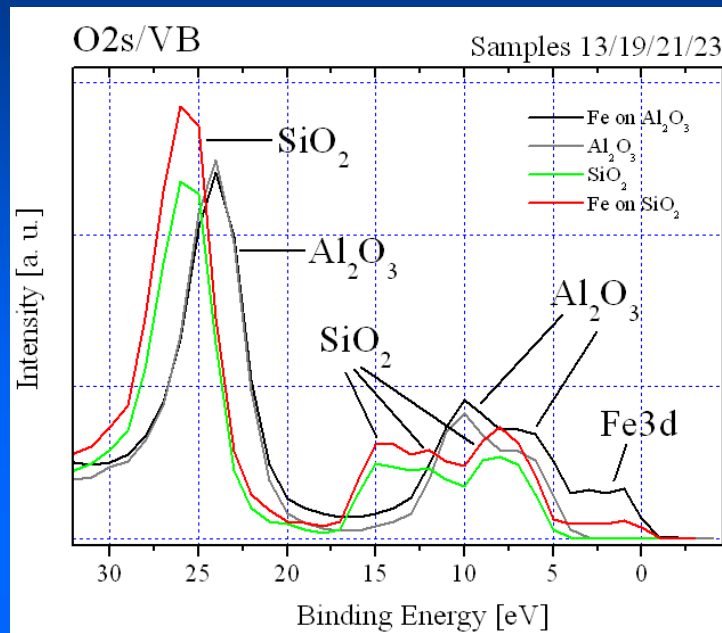

## Identification of FE:

In case of low DOS near  $E_F$ , band gap or charged samples (spectrum will move in this case!)

à Look for reference peaks with known BE (be sure about that!!!)

à Works for any PE or Auger peak, e.g. peaks originating from substrate

# Chemical Shift

BE of core electrons depends on the electron density of the atom (screening of the core electrons), affected by the electronegativity of neighboring atoms

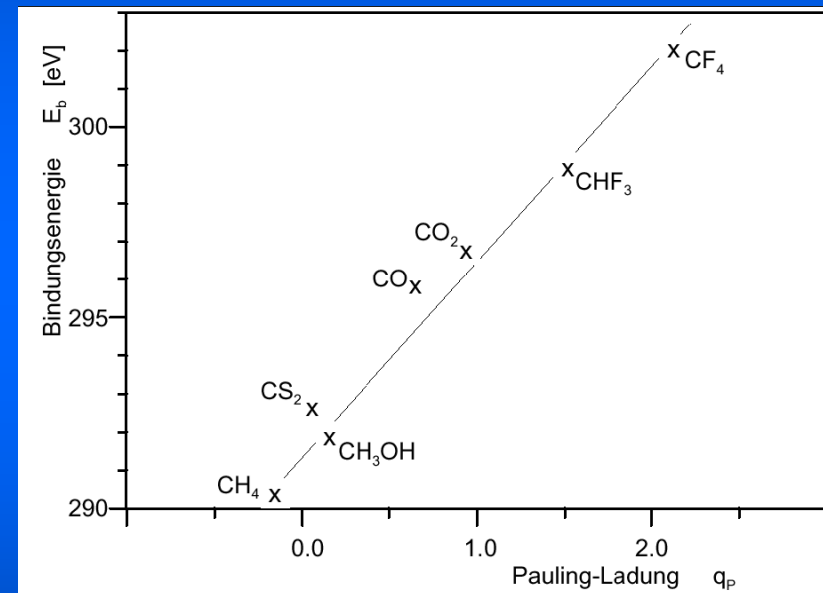
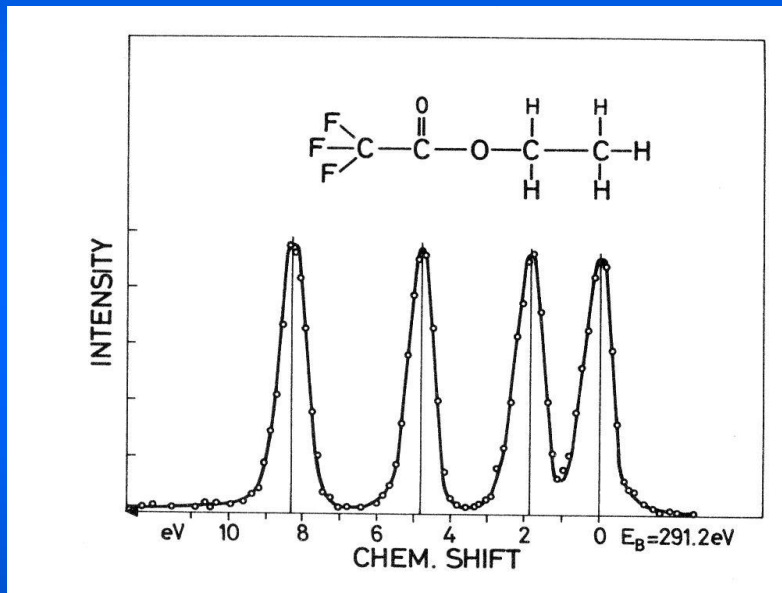

For unknown BE:

- Calculation of Pauling's Charge (easy, but not always true)
- More elaborate calculations (theorists, also not always true)

# Analyzing the data: Chemical States

Table 3.6 N 1s binding energies. (Reproduced from Wagner *et al.*<sup>27</sup> by permission of Perkin-Elmer Corporation)

COMPOUND	1s BINDING ENERGY, eV				
	394	398	402	406	410
BuNH <sub>2</sub>					
PhNH <sub>2</sub>					
pyridine					
H <sub>2</sub> NCH <sub>2</sub> NO <sub>2</sub>					
H <sub>2</sub> NSO <sub>2</sub> C <sub>6</sub> H <sub>4</sub> NO <sub>2</sub>					
tetracyanoquinodimethane					
PhCN					
PhNHCSNHPh					
guanidine HCl					
phthalocyanine					
PhNNPh					
H <sub>3</sub> N <sup>+</sup> CHRCOO <sup>-</sup>					
EtNH <sub>3</sub> Cl					
Me <sub>3</sub> NBr					
Me <sub>3</sub> NCl					
p-NH <sub>3</sub> <sup>+</sup> C <sub>6</sub> H <sub>4</sub> SO <sub>3</sub> <sup>-</sup>					
chloranil-pyridine					
Me <sub>3</sub> NO					
AmONO					
MeNO <sub>2</sub>					
PhNO <sub>2</sub>					
WN					
BN					
NaSCN					
K <sub>4</sub> Fe(CN) <sub>6</sub>					
KCN					
S <sub>2</sub> N <sub>2</sub>					
Co(NH <sub>3</sub> ) <sub>6</sub> Cl <sub>2</sub>					
N <sub>2</sub> H <sub>6</sub> SO <sub>4</sub>					
(NH <sub>3</sub> OH) <sup>+</sup> Cl <sup>-</sup>					
NH <sub>4</sub> NO <sub>3</sub>					
Na <sub>2</sub> N <sub>2</sub> O <sub>2</sub>					
NaN <sub>3</sub>					
NaNO <sub>2</sub>					
NaNO <sub>3</sub>					

## References:

- Use of data bases (NIST, Handbook of Photoelectron Spectroscopy etc.)\*)
- Clean materials (pure metals, well defined substrates, „untreated“ samples etc.)
- Literature about similar topics

\*„Handbook of Photoelectron Spectroscopy“, Perkin-Elmer, 1992  
 G. Ertl, J. Küppers;  
 “Low Energy Electrons and Surface Chemistry”; VCH Verlag, 1985  
 S. Hüfner; “Photoelectronspectroscopy”; Springer, 1995.  
 D. Briggs, M.P. Seah;  
 “Practical Surface Analysis”, Vol. 1; Wiley + Sons, 1990.

# Analyzing the data: Peak Fitting

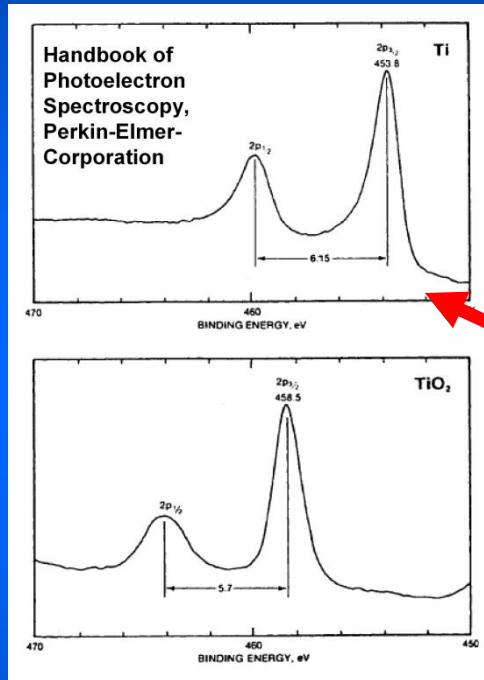

## Several influences on peak shape:

- Broadening mainly due to exciting light (natural), structural and thermal effects
- Asymmetry due to final state effects
- Species with similar BE

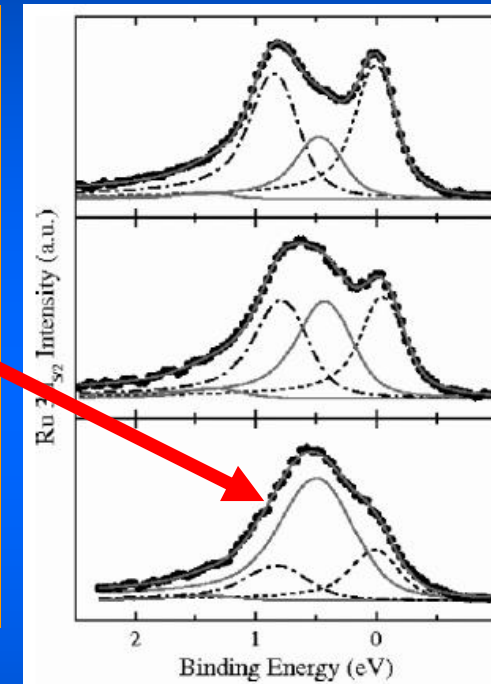

These effects have to be considered when fitting by reasonable chemical/physical model of the sample!!!

# Analyzing the data: Peak Fitting

Most fitting programs provide useful tools:

Levenberg-Marquardt algorithm to minimize the  $\chi^2$

$$\chi^2(p) = \frac{1}{N-P} \sum_i \left[ \frac{M(i) - S(i; p)}{\sqrt{M(i)}} \right]^2$$

M: measured spectrum  
N: energy values  
S: synthesized spectrum  
P: parameter values

Asymmetric Peak shapes modeled by Doniach-Sunjic functions (convoluted with Gaussian profiles)

$$DS(E) = \beta \cdot \frac{\cos \left\{ \pi \frac{\alpha}{2} + (1 - \alpha) \arctan \left[ \frac{E - E_0}{\beta} \right] \right\}}{[(E - E_0)^2 + \beta^2]^{\frac{1-\alpha}{2}}}$$

b: peak parameter  
M: mixing ratio  
a: asymmetry parameter  
h: peak height  
a  $\rightarrow$  0: Lorentzian profile

Convolution of Lorentz (or D.S.) Gaussian profiles suited best!!

$$f(E) = f(L * G) = \int_{-\infty}^{\infty} L(E') G(E - E') dE'$$

$\rightarrow$  Voigt function



# Analyzing the data: Peak Fitting

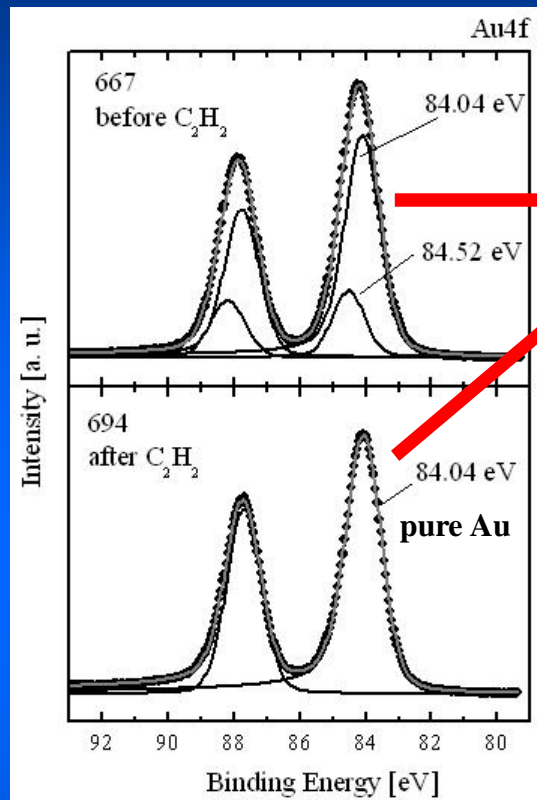

## Strategy:

- Use of references for asymmetry and broadening
- Reasoning of most likely chemical composition

Peak broadening and asymmetry *should* be the same for same component in different spectra

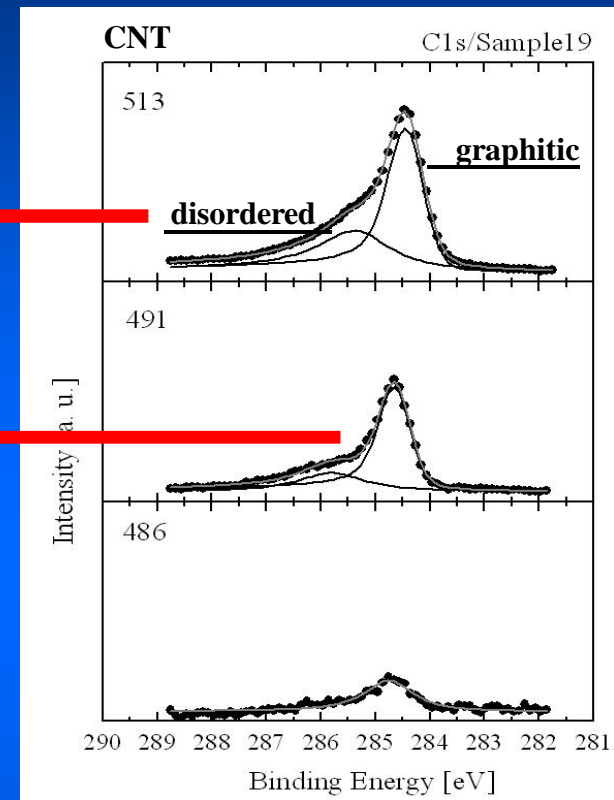

But: both may differ for different components

à discrepancy for different peaks should always be based on physical reasons

# Quantitative Analysis

## Goal:

### Elemental composition

- Species of atoms on surface
- Concentration of surface atoms
- Vertical distribution
  - on surface (adsorbate)
  - near surface

### Molecular state of adsorbates

### Oxidation state of surface species

- $\text{Me}^0 \rightleftharpoons \text{Me}^{n+}$

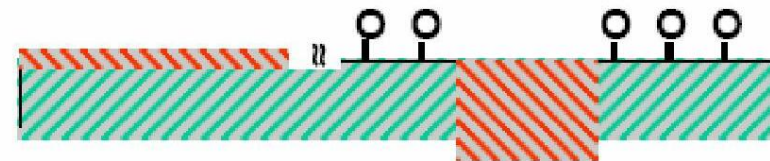
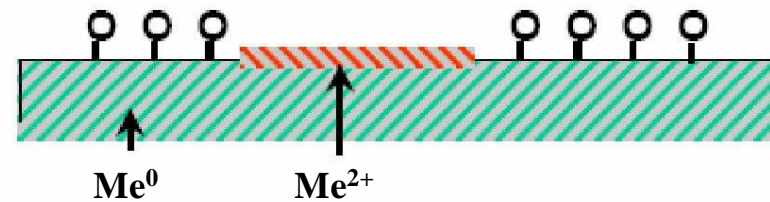
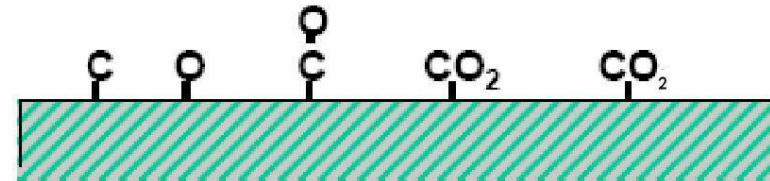



# Quantitative Analysis: First Steps

In general:

$$I_X = B \cdot s \cdot I_{\text{tot}} \cdot T \cdot n_X$$

B: all instrumental contributions

s: ionisation cross section for given photon energy

$I_{\text{tot}}$ : total escape depth

T: transmission through surface

$n_X$ : atomic density of analyzed species in sample

$$s = s_{\text{tot}} \cdot f(X, a)$$

$$\text{with } f(X, a) = 1 + \frac{b(X)}{4} (1 - 3\cos^2 a)^*$$

$s_{\text{tot}}$ : total ionisation cross section

f: form function accounting for asymmetry of peak

b: asymmetry parameter

a: angle between photon beam and emitted electron  
(different for standard x-ray source and synchrotron)

\*Yeh and Lindau, Atomic data nucl. data tables 32(1985)1

$$I_{\text{tot}} = E(X) \cdot 1/a [\ln(E(X) - b)]^*$$

E: KE of electron

a, b: parameters dependent on dielectric function and concentration of host

\*Penn, J. of Electr. Spectr. And Rel. Phen. 9(1976)29

Cross section changes with energy of incident beam!!!

# Quantitative Analysis: Cross Section

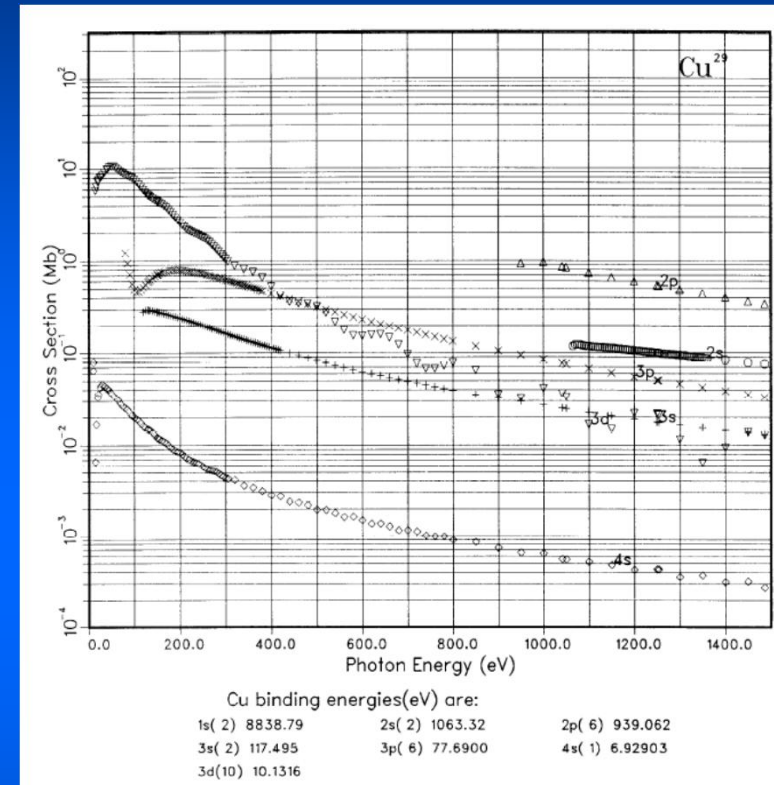
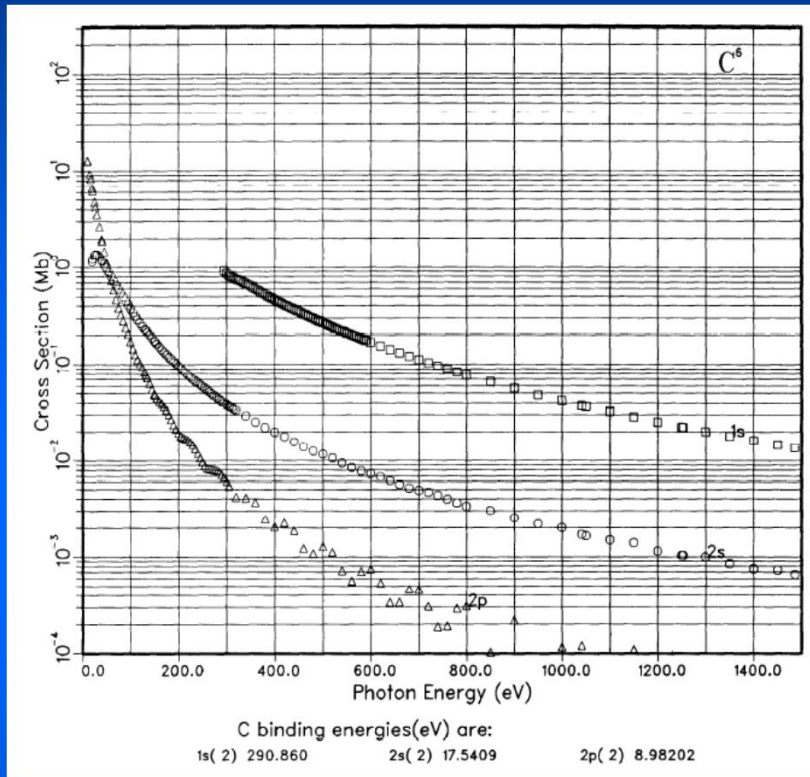

Calculated changes of Cross section beam energy

(Yeh, Lindau; Atomic data and nuclear data tables 32 (1985) 1)

## Quantitative Analysis

In most cases the sample surface is quite heterogeneous

à Need of *models* to extract an accurate approximation of composition out of spectral intensities

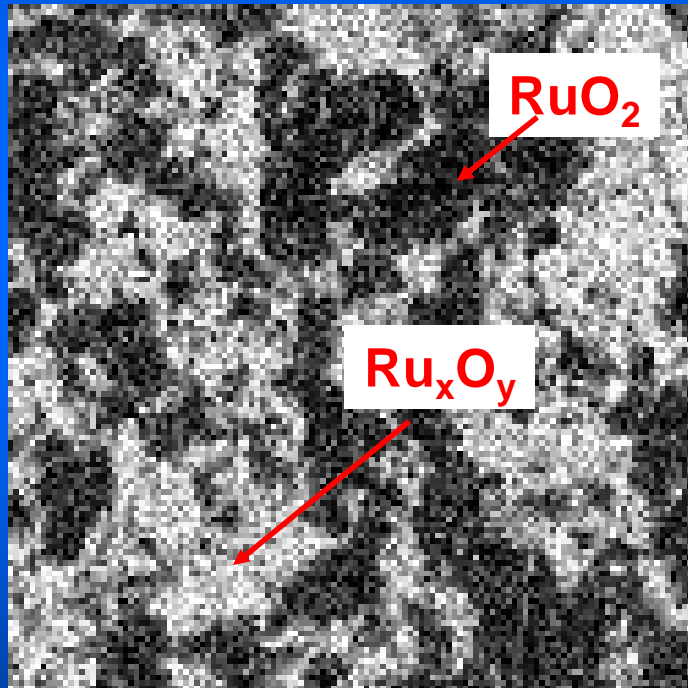

Ru 3d5/2-map of the chemical states on Ru(0001) after pre-treatment with O performed with Scanning Photoelectron Microscopy (ELETTRA):

# Quantitative Analysis: Useful Examples

A. Heterogeneous mixture (e.g. alloy):

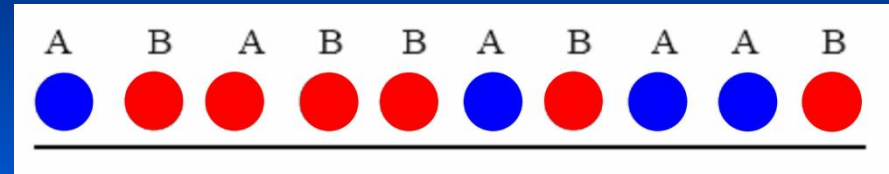

with the formulas  
above follows

$$\frac{I_A}{I_B} \cdot \frac{I_B^0}{I_A^0} = \frac{N_A}{N_B} \cdot \frac{N_B^0}{N_A^0} \cdot \frac{\lambda_{AB}(E_A)}{\lambda_{AB}(E_B)} \cdot \frac{\lambda_B(E_B)}{\lambda_A(E_A)}$$

and

$$\lambda_A = 0.41 \cdot a_A^{1.5} \cdot E_A^{0.5}$$

$$\frac{N_A}{N_B} \cdot \frac{N_B^0}{N_A^0} = \frac{X_A}{X_B} \cdot \left( \frac{a_A}{a_B} \right)^3$$

$a_A$ : „radius of A“

à Mol fraction

follows

$$\frac{X_A}{X_B} = \left( \frac{a_B}{a_A} \right)^{1.5} \cdot \frac{I_A / I_A^0}{I_B / I_B^0}$$

$I_{A,B}^0$ : reference of  
clean material

# Quantitative Analysis: Useful Examples

## B. Partial Coverage (e.g. adsorbat):

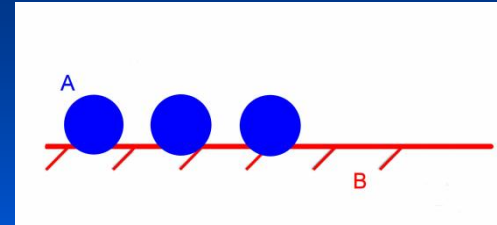

Contribution of B:

$$I_B = I_B \text{ (direct)} + I_B \text{ (attenuated by A)}$$

$$= (1 - \Theta_A) I_B^0 + I_B^0 \Theta_A \exp\left(-\frac{a_A}{\lambda_A \cos \Theta}\right)$$

Q: angle between surface normal and emitted electron

For signals of A and B follows

$$I_B = I_B^0 \left[ 1 - \Theta_A + \Theta_A \cdot \exp\left(-\frac{a_A}{\lambda_A \cos \Theta}\right) \right]$$

$\Theta_A$ : coverage of A on B

$$I_A = I_A^0 \cdot \Theta_A$$

Which gives

$$\frac{I_A}{I_B} = \frac{I_A^0}{I_B^0} \cdot \frac{\Theta_A}{1 - \Theta_A \left[ 1 - \exp\left(-\frac{a_A}{\lambda_A \cos \Theta}\right) \right]}$$

$I_{A,B}^0$ : reference of clean material

# Quantitative Analysis: Useful Examples

## C. Thin layer of A on B (e.g. oxide):

### Contribution of B:

$$I_B = I_B^0 \exp\left(-\frac{d_A}{\lambda_A(E_B)} \cdot \cos\Theta\right)$$

### Contribution of A:

$$I_A = I_A^0 \exp\left[1 - \exp\left(-\frac{d_A}{\lambda_A(E_A)} \cos\Theta\right)\right]$$

### Which gives

$$\frac{I_A}{I_B} = \frac{I_A^0}{I_B^0} \cdot \frac{1 - \exp\left(-\frac{d_A}{\lambda_A(E_A)} \cos\Theta\right)}{\exp\left(-\frac{d_A}{\lambda_A(E_B)} \cos\Theta\right)}$$

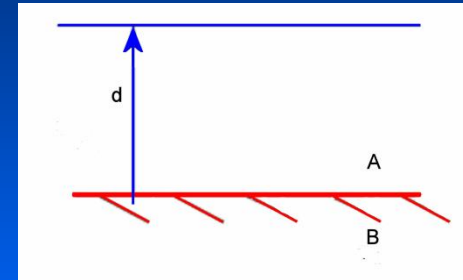

### è Special case:

$$\lambda_A(E_A) \sim \lambda_A(E_B) \quad \text{i.e.} \quad E_A \sim E_B$$

### follows

$$d_A \approx \frac{\lambda_A}{\cos\Theta} \cdot \ln\left[1 + \frac{I_A}{I_B} \cdot \frac{I_B^0}{I_A^0}\right]$$

General problem here:  
proper background subtraction

# In situ XPS: obstacles

## Fundamental limit:

elastic and inelastic scattering of electrons in the gas phase

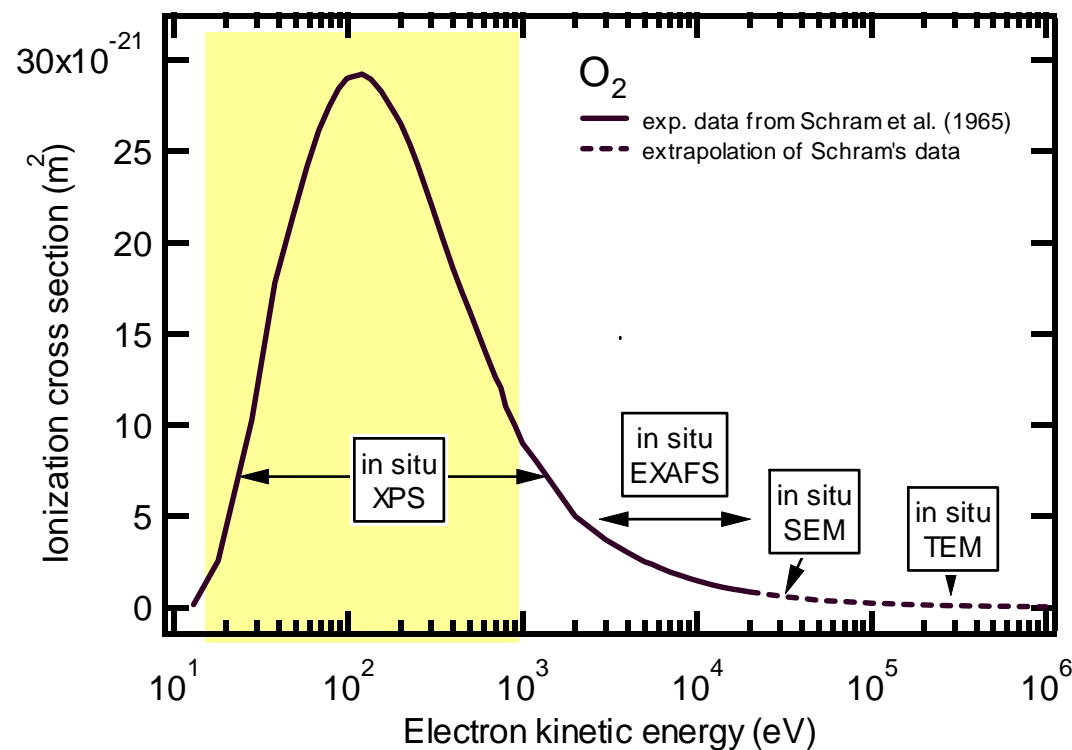

## Technical issues:

- Differential pumping to keep analyzer in high vacuum
- Sample preparation and control in a flow reactor

## In situ XPS: basic concept

---

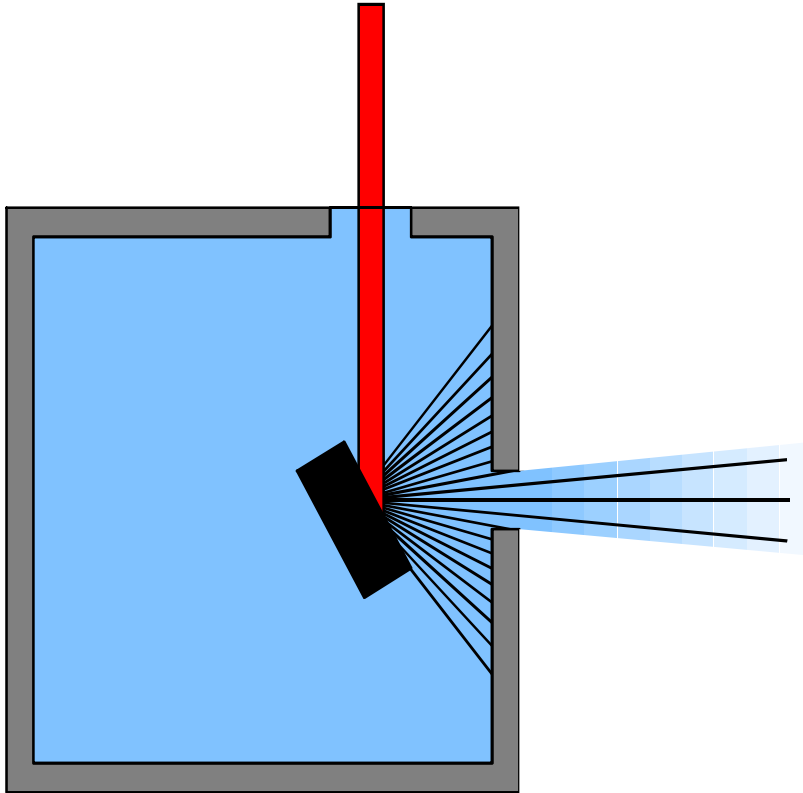

- Photons enter through a window
- Electrons and a gas jet escape through an aperture to vacuum



# In situ XPS instruments: previous designs

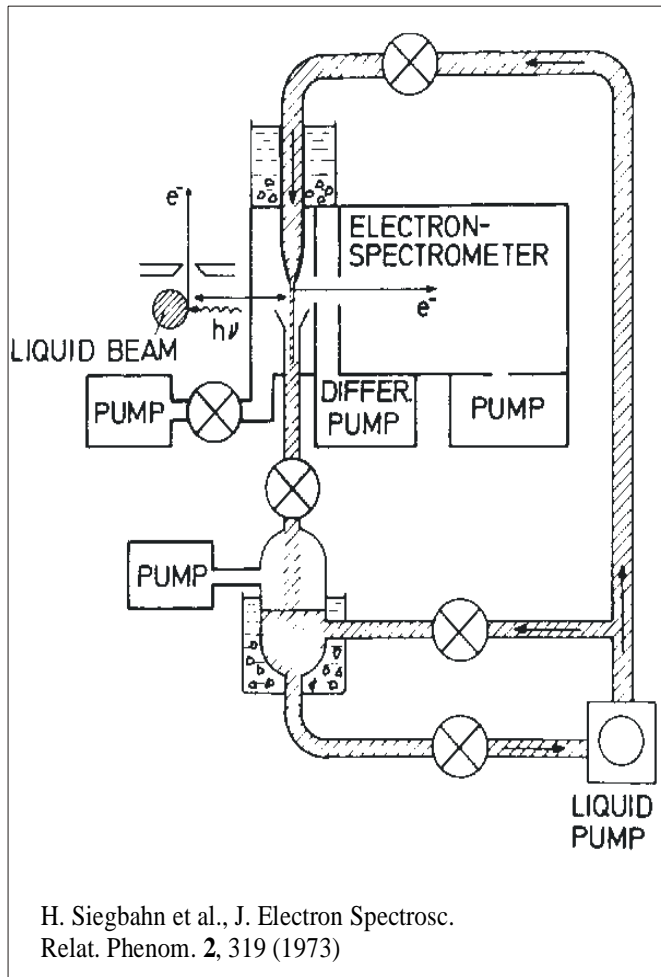

- H. Siegbahn et al. (1973- )
- M.W. Roberts et al. (1979)
- M. Faubel et al. (1987)
- M. Grunze et al. (1988)
- P. Oelhafen (1995)

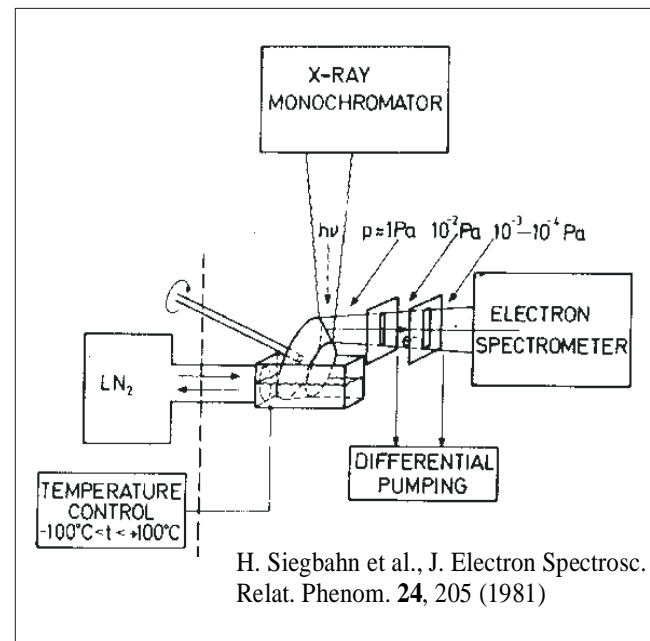

# In situ XPS using differentially pumped electrostatic lenses

---

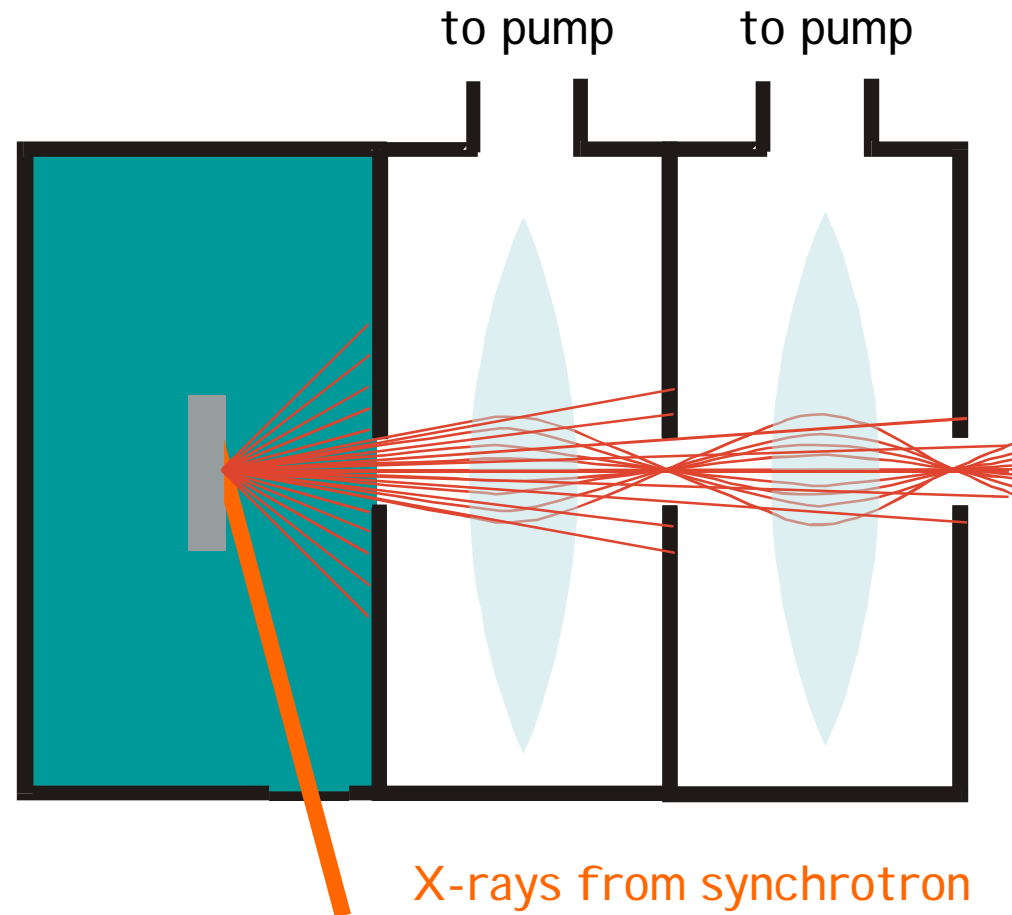

## Close-up of sample-first aperture region

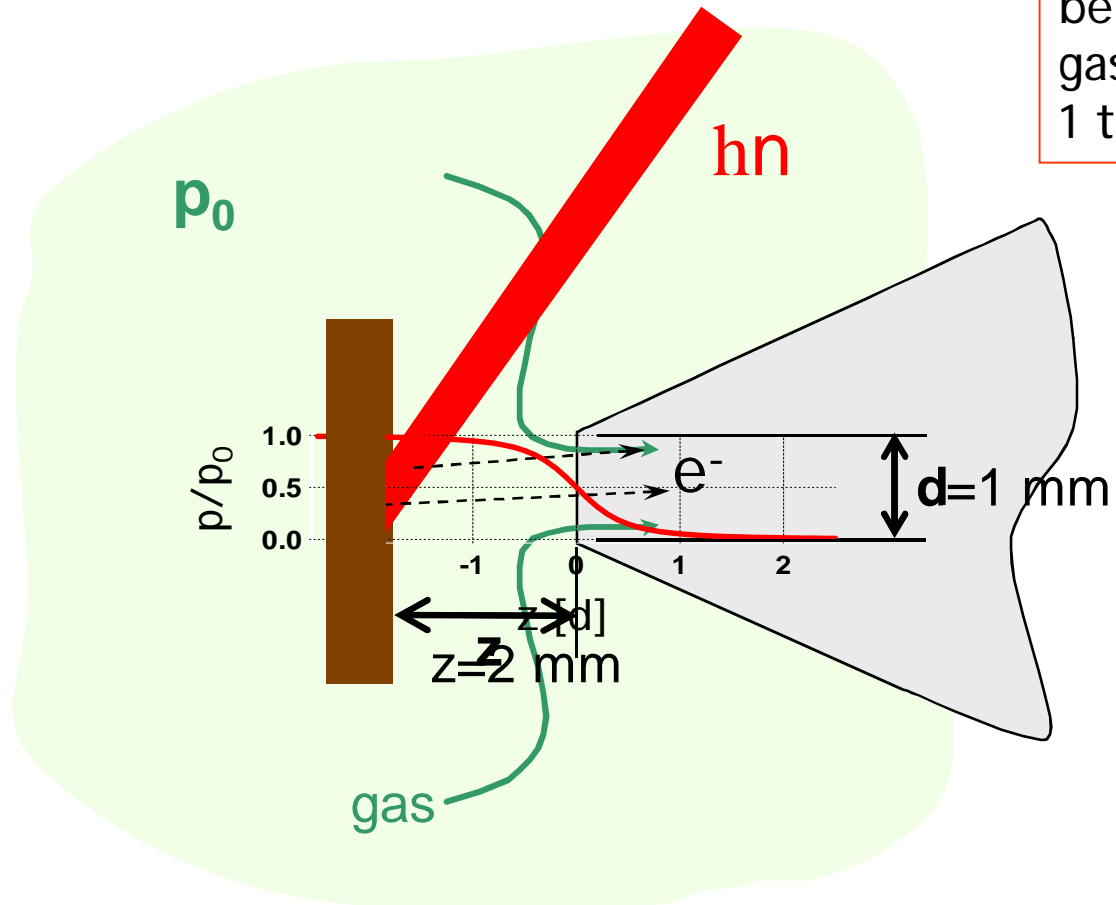

Gas phase composition can be measured by XPS.  
gas phase signal:  
1 torr·mm ~ a few monolayers

# In situ XPS system

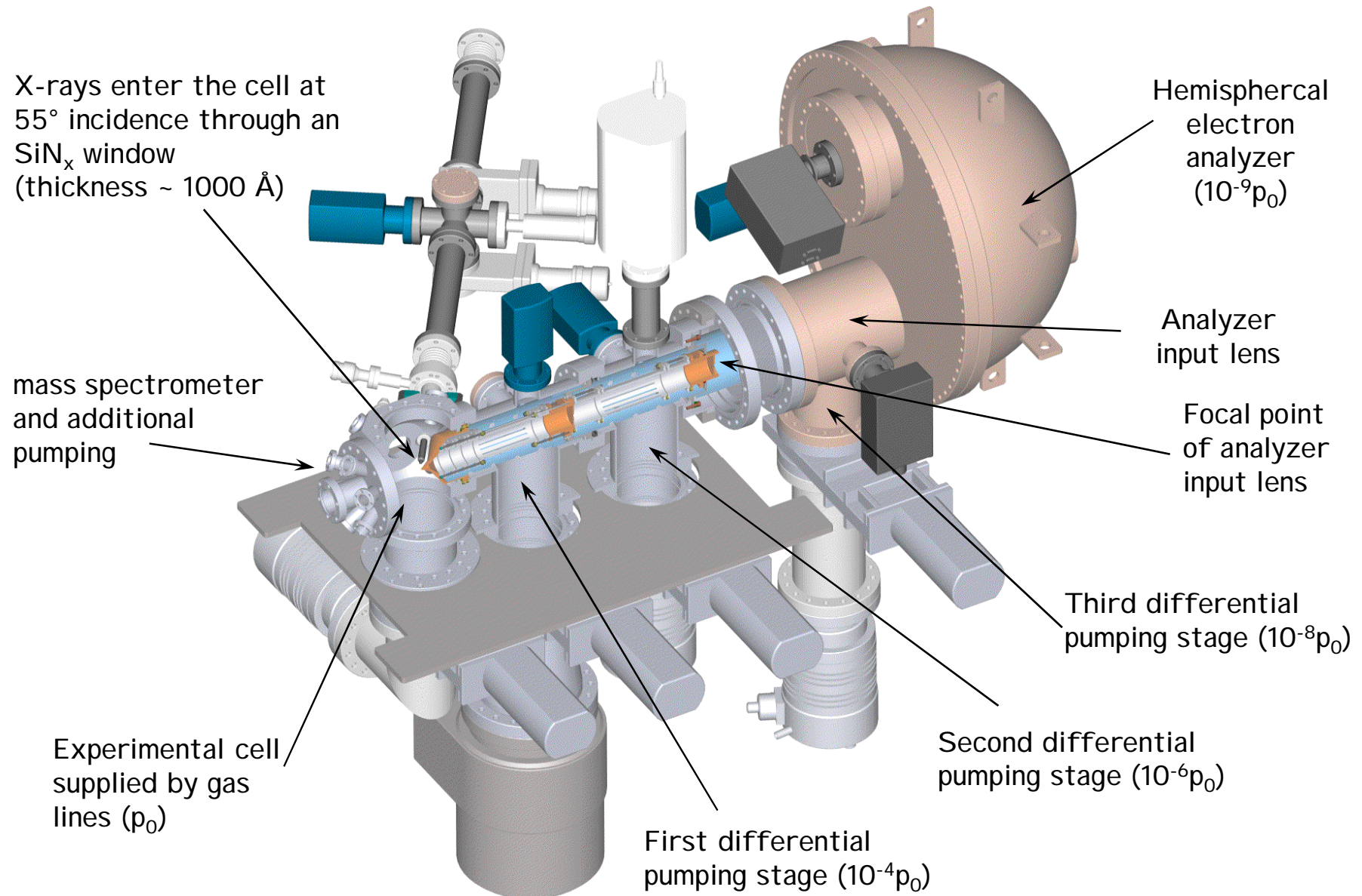

## Application of in situ XPS to catalysis: methanol oxidation on Cu

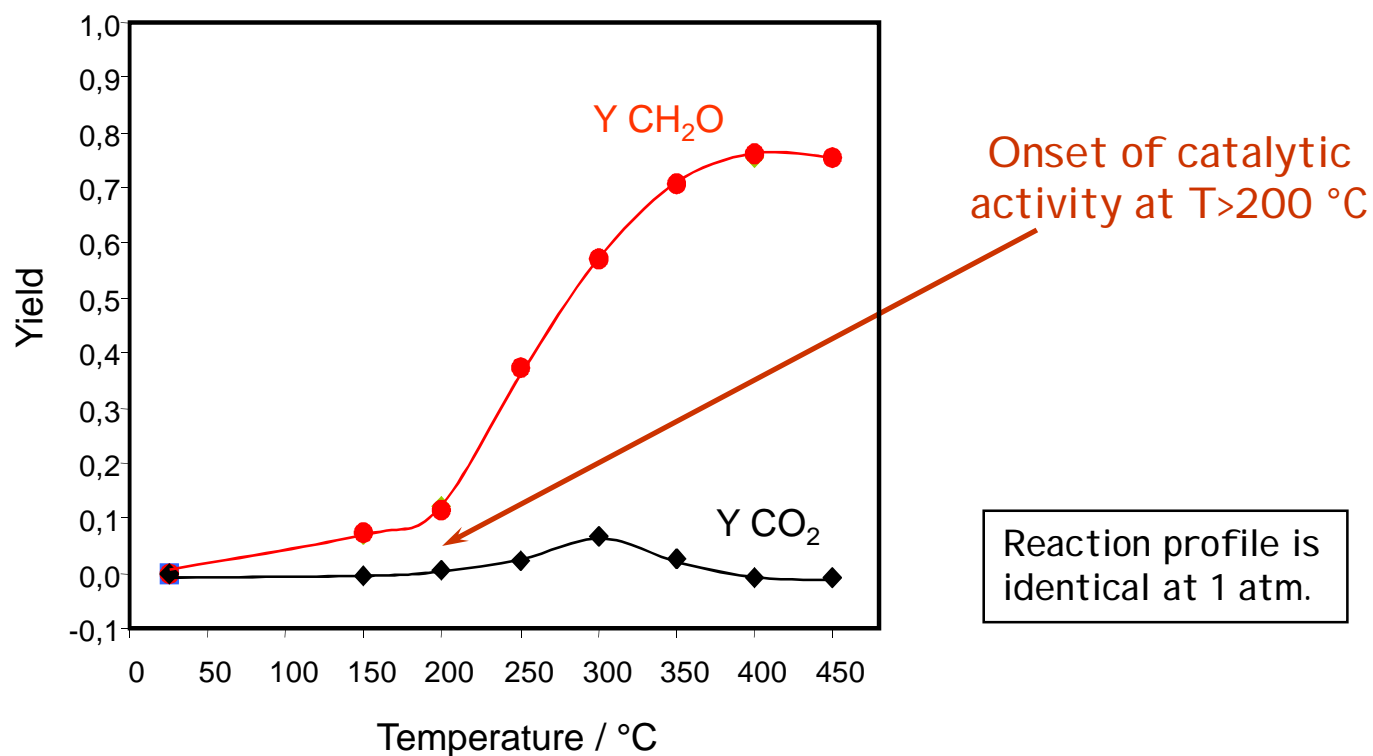
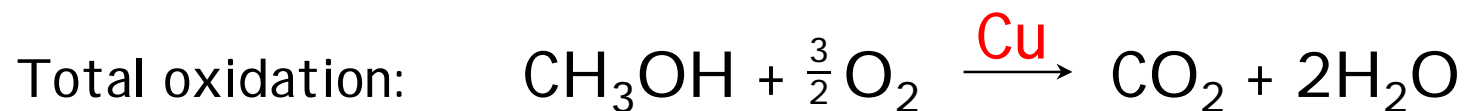
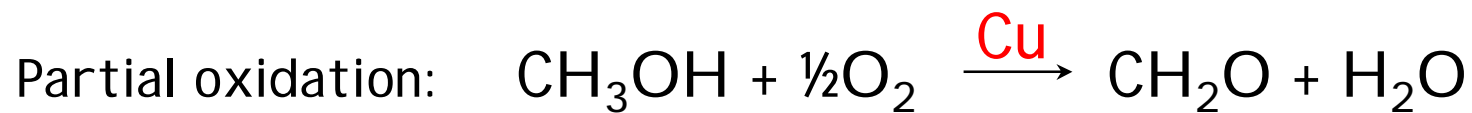

What is the state of the surface under reaction conditions?

## UHV XPS

I.E. Wachs & R.J. Madix, *Surf. Sci.* 76, 531 (1978); A. F. Carley et al., *Catal. Lett.* 37, 79 (1996).

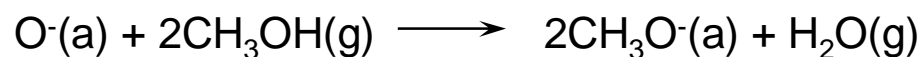

## In situ NEXAFS

A. Knop-Gericke et al., *Topics Catal.* 15, 27 (2001).

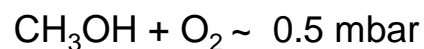

suboxide phase:

- only present in situ

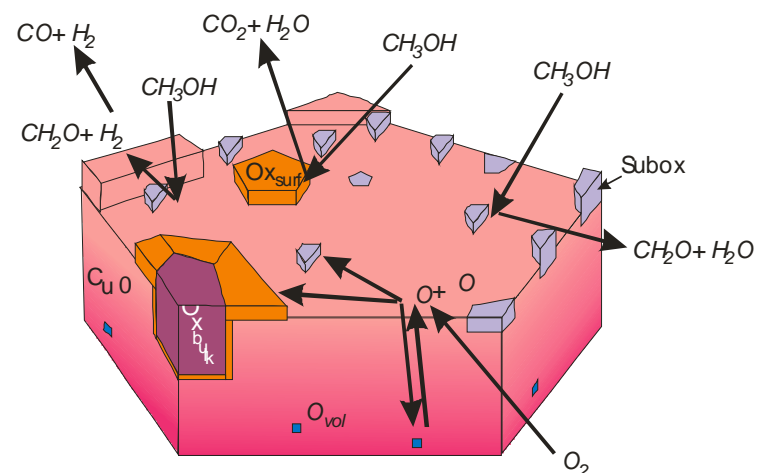

- Questions for in situ XPS:
- Quantitative analysis of surface species
  - Carbon species on the surface
  - Depth-dependent analysis

# Experimental conditions

---

sample: polycrystalline Cu foil

Variations of mixing ratios:  $\text{CH}_3\text{OH} : \text{O}_2 = 1:2, 3:1, 6:1$ ;  $T = 400\text{ }^\circ\text{C}$ ;  $p = 0.6\text{ mbar}$

Temperature series: gas mixture at room temperature:  $\text{CH}_3\text{OH} : \text{O}_2 = 3:1$ ;  
 $p = 0.6\text{ mbar}$ ; temperature:  $25\text{ }^\circ\text{C} @ 450\text{ }^\circ\text{C}$

flow rates: 10 ... 20 sccm

## XPS measurements

Beam line U49/2-PGM1 at Bessy

Energy range 100...1500 eV

total spectral resolution 0.1 eV @ 500 eV

O 1s, C 1s, Cu 3p, Cu 2p: KE ~ 180 eV

Valence Band: KE ~ 260 eV

Depth profiling with KEs 180 eV, 350 eV,  
500 eV, 750 eV

# Methanol oxidation on Cu: O1s spectra

400 °C, 0.5 torr

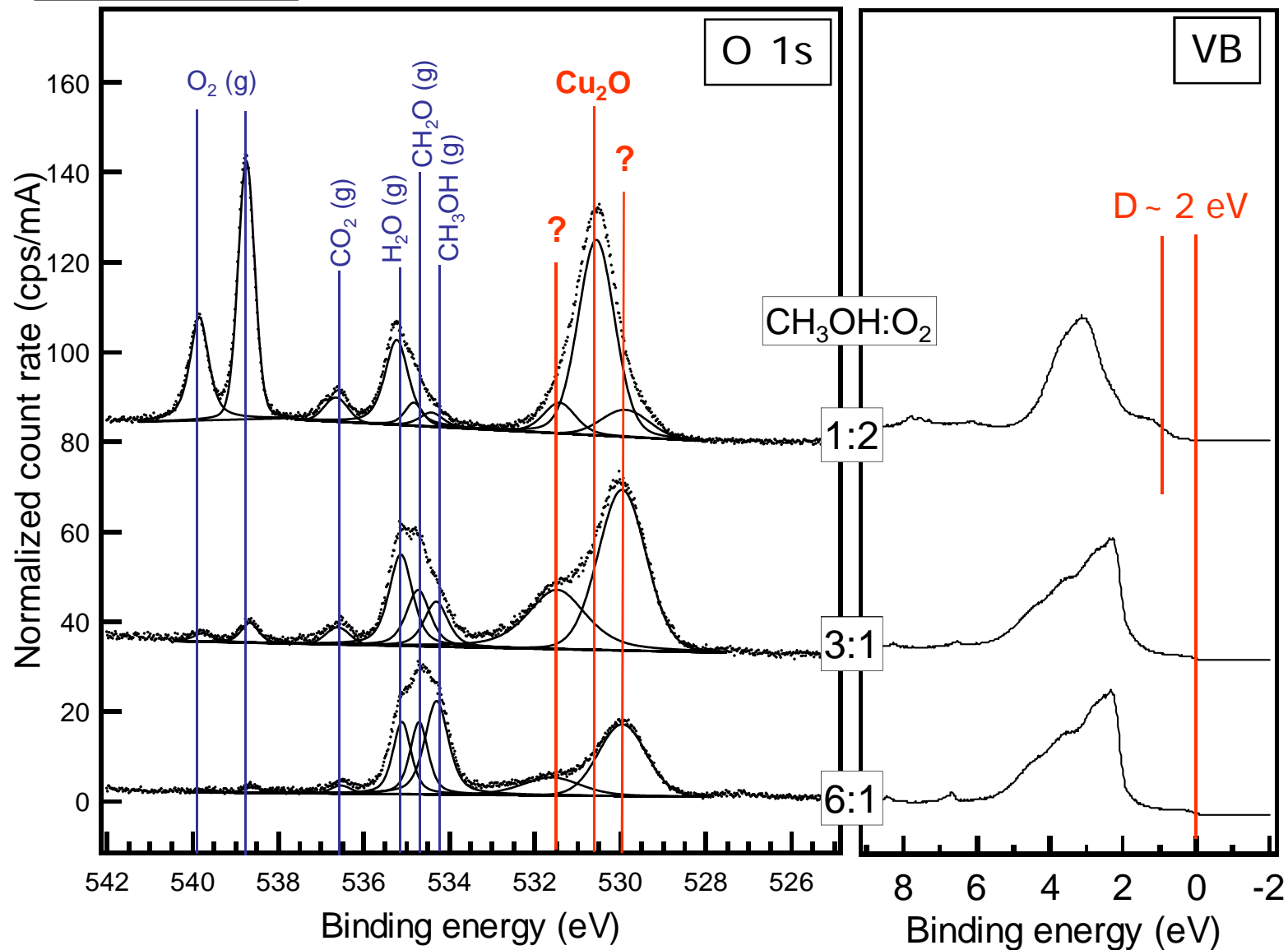



# O1s depth profiling

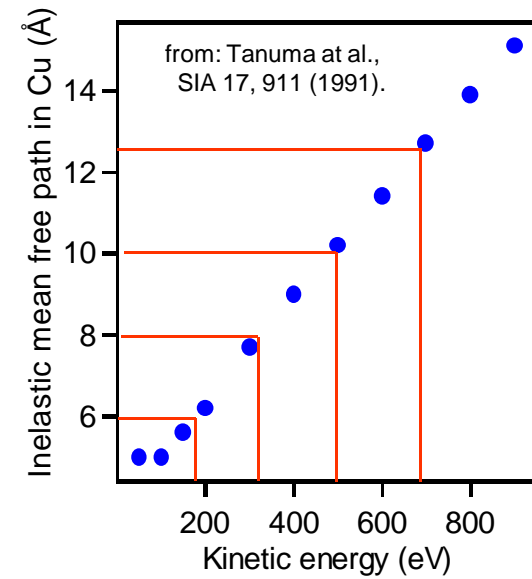
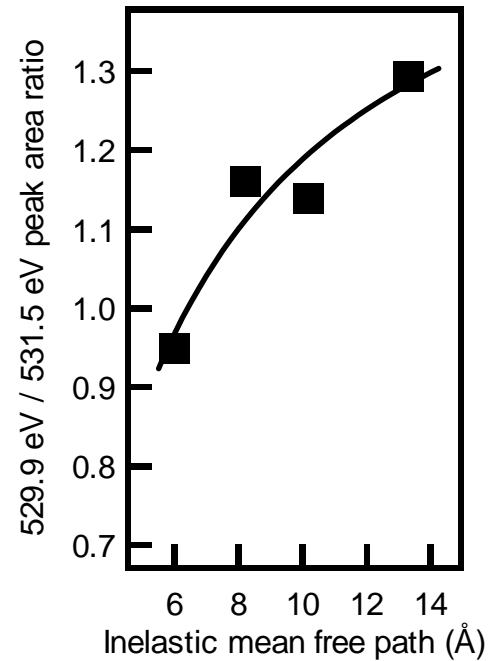
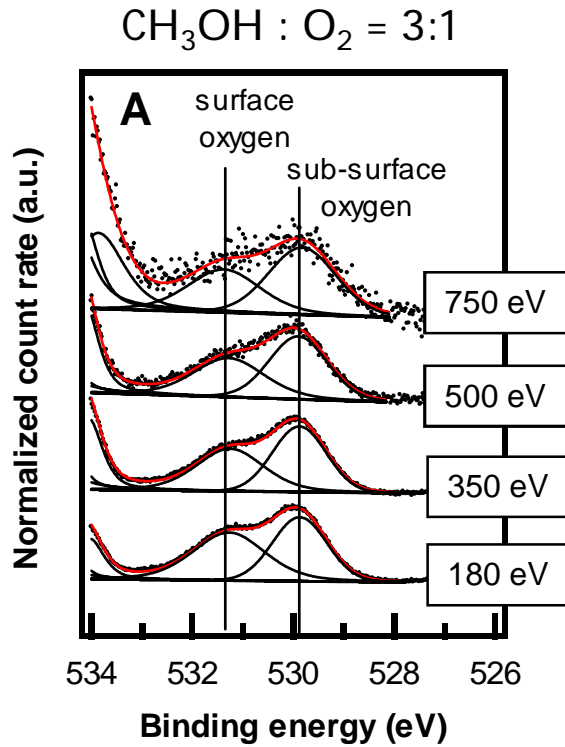

$$I_{529.9} / I_{531.5} = n_{529.9} / n_{531.5} \cdot \exp[-(z_{531.5} - z_{529.9}) / \lambda]$$

$$Dz = 3 \text{ \AA}, n_{529.9} / n_{531.5} = 1.6$$

# Methanol oxidation on Cu: C1s spectra

400 °C

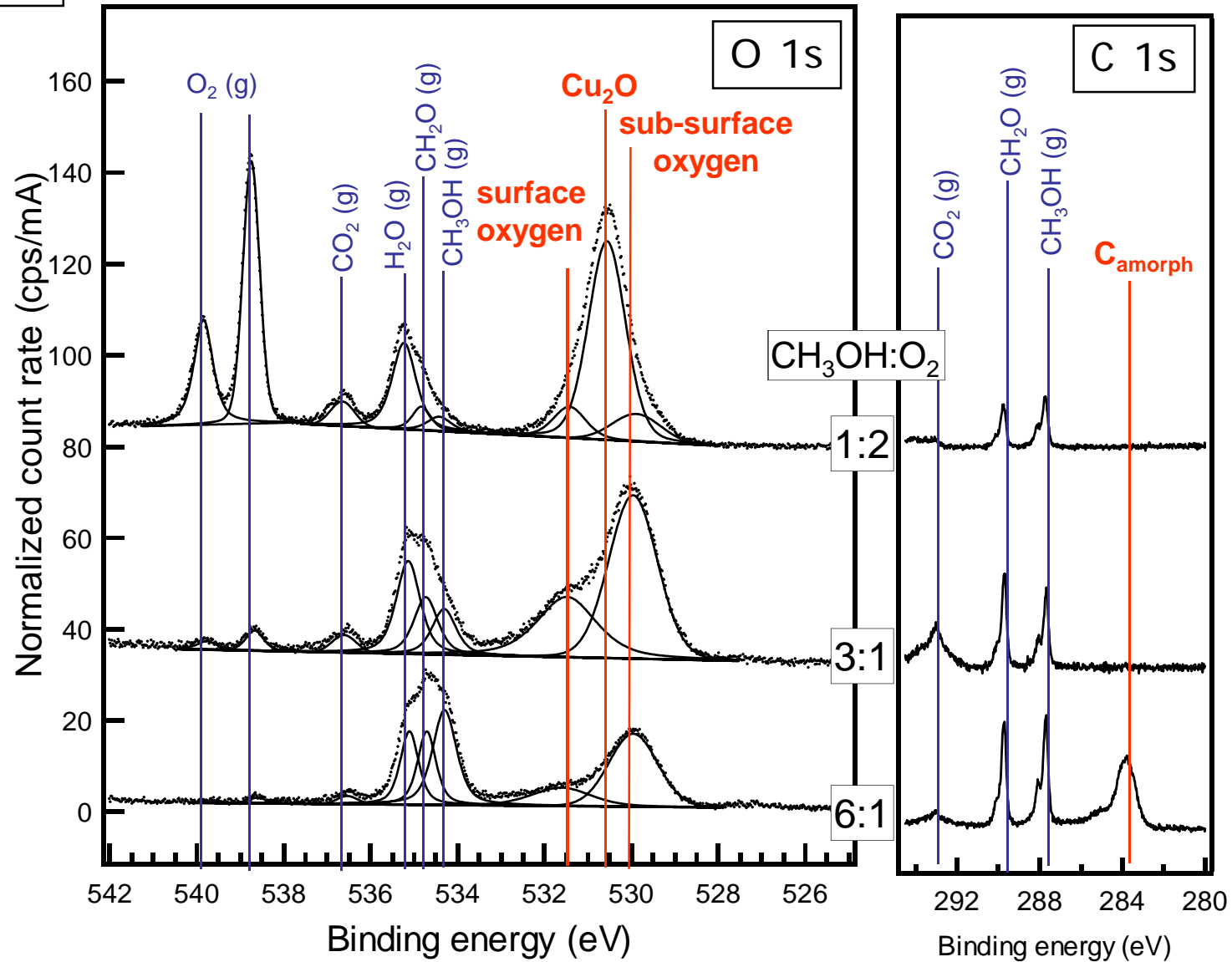

# Metastability of the Sub-Surface Oxygen

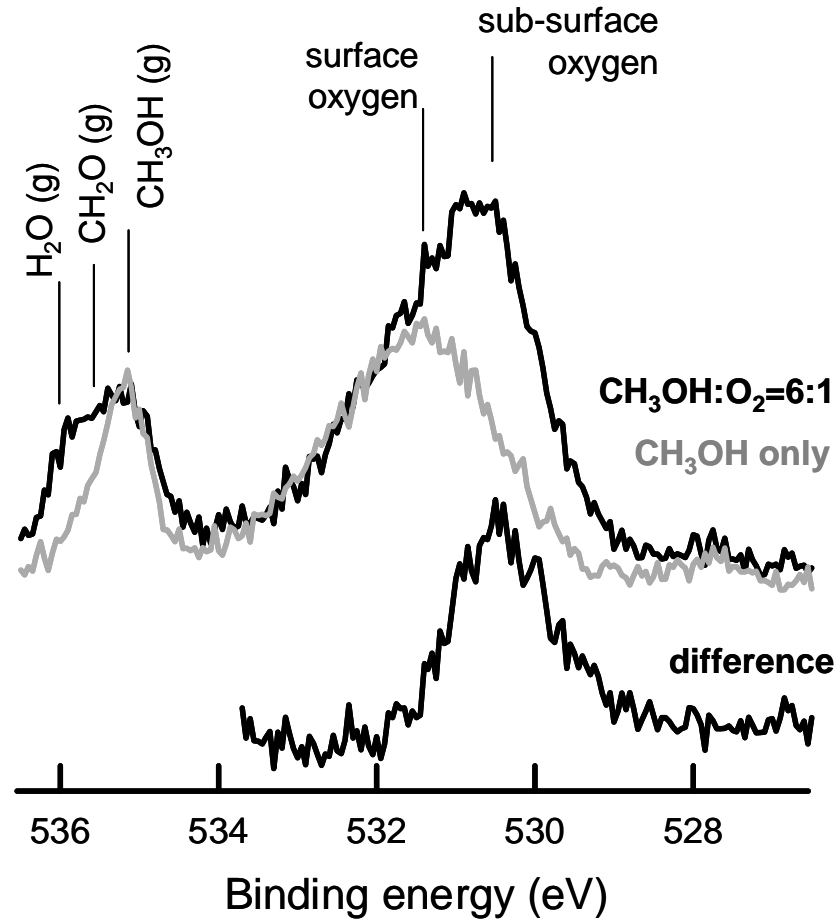

# Correlation of catalytic activity and surface species

## CH<sub>2</sub>O yield vs sub-surface oxygen peak area

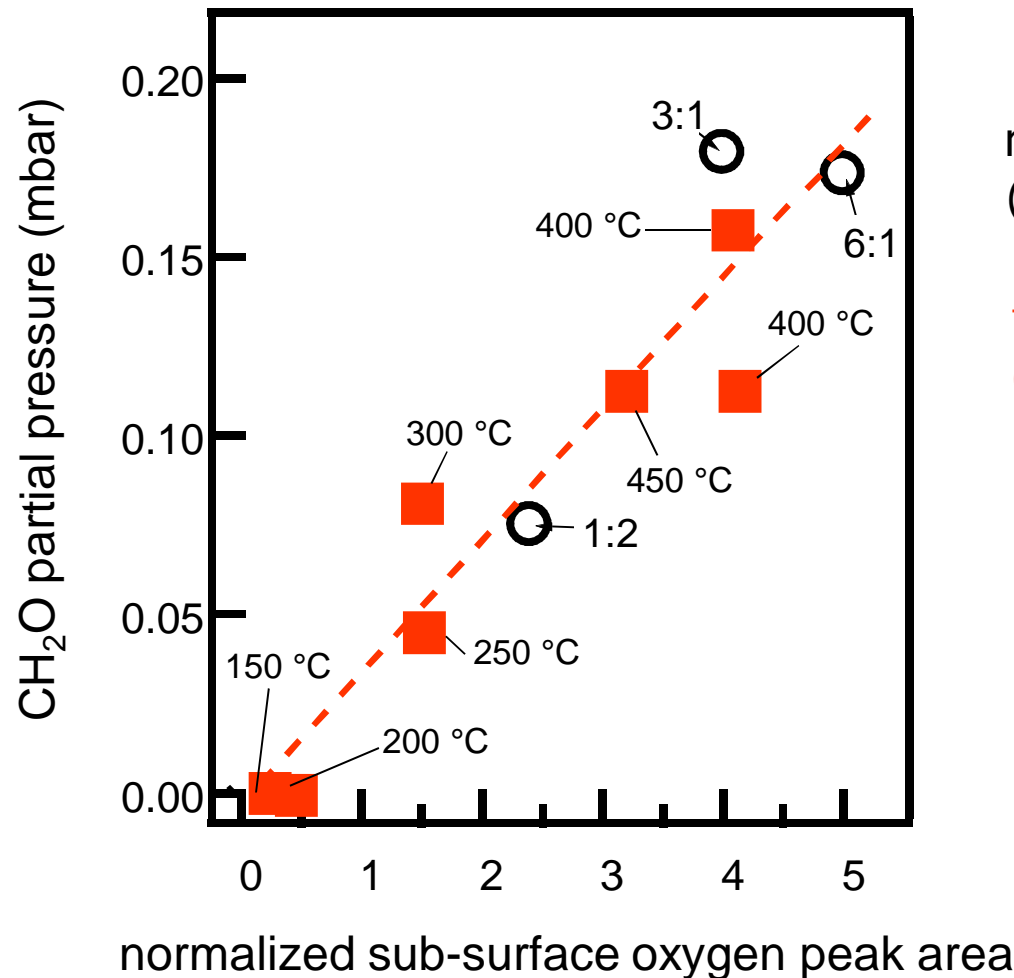

mixing ratio series  
(T = 400 °C)

temperature series  
(CH<sub>3</sub>OH:O<sub>2</sub>=3:1)

Open questions:  
What is the nature of the sub-surface oxygen species?  
What is its role in the catalytic reaction?

# Depth profiling

(calculated from Cu 3*p* and sub-surface O 1*s*)

## Reducing conditions

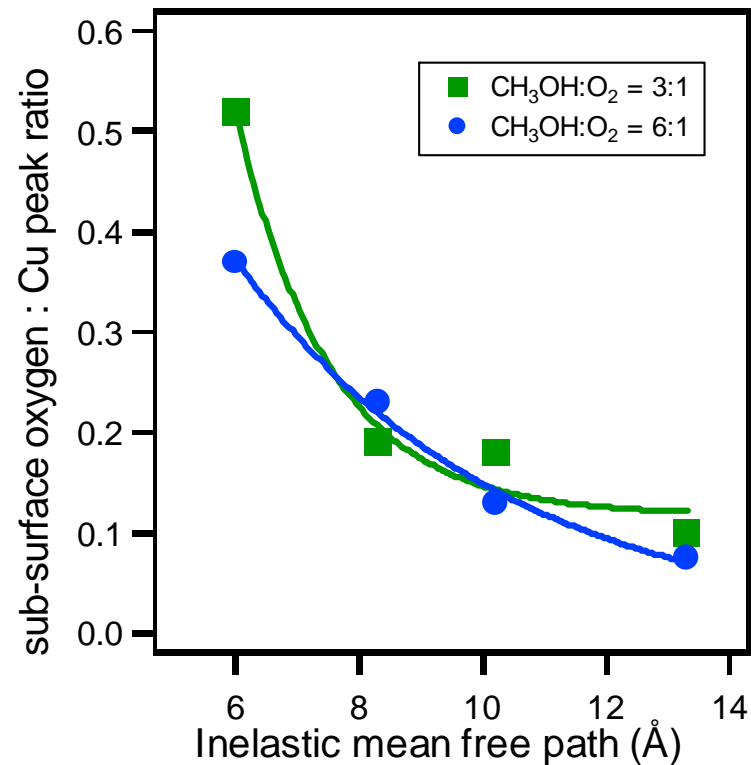

Open questions: What is the nature of the sub-surface oxygen species?  
What is its role in the catalytic reaction?

## Energy Conversion

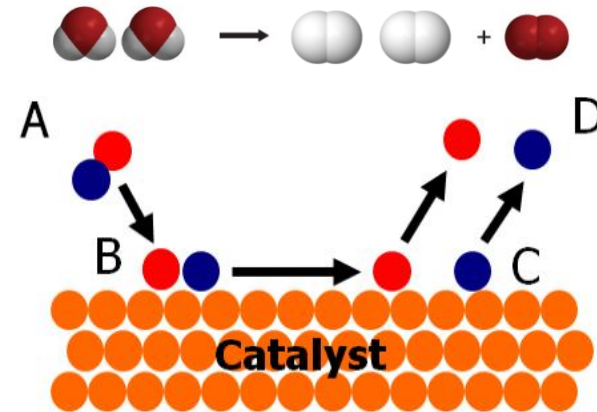
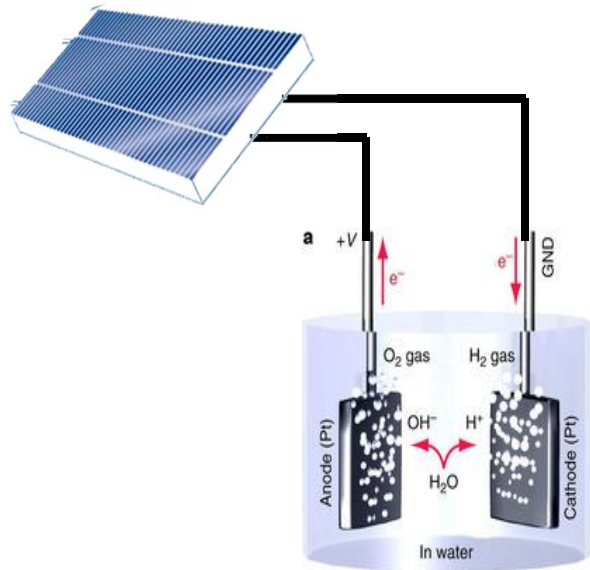
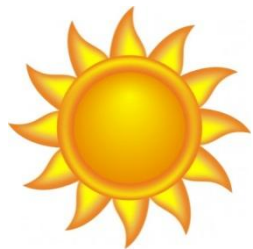

### ■ Wasserspaltung

- Ø Pt
- Ø IrO<sub>x</sub>
- Ø Co/C
- Ø Mg/C
- Ø Etc...

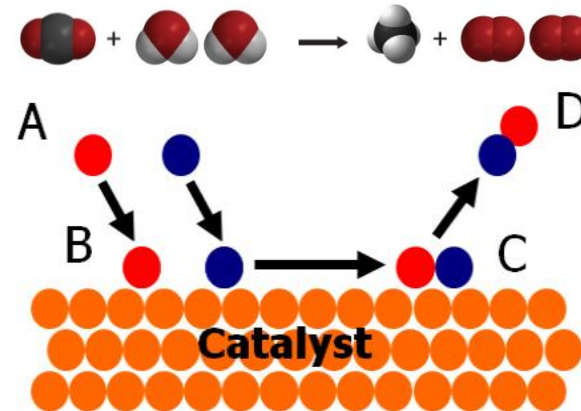

### ■ Kathodische CO<sub>2</sub>-Reduktion

- Ø CuOx

# Spectroscopy in liquid

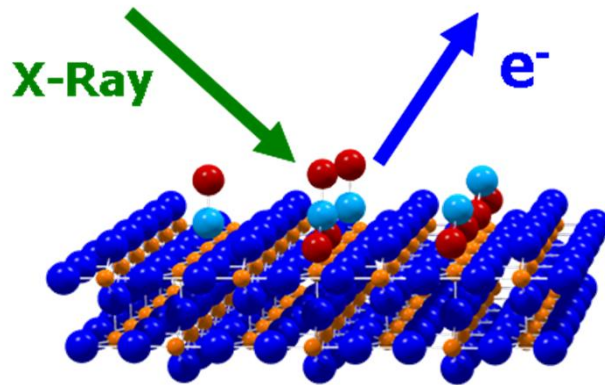
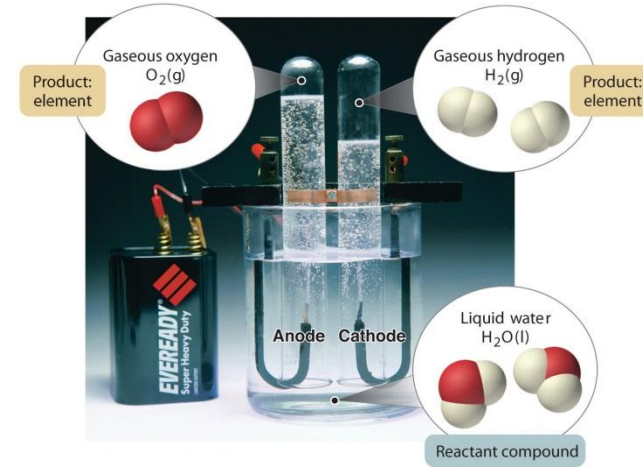
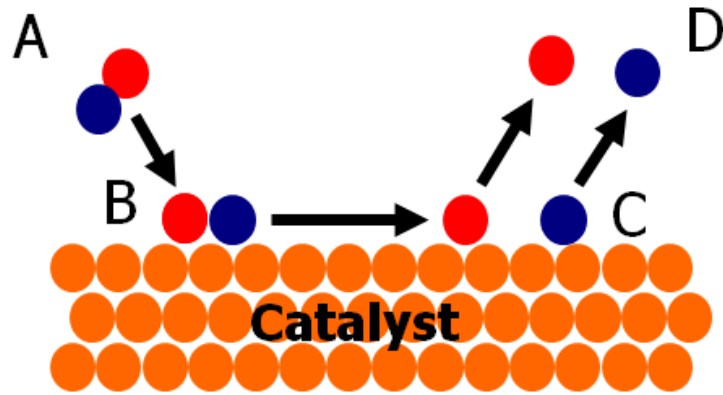

The "universal electron scattering curve"

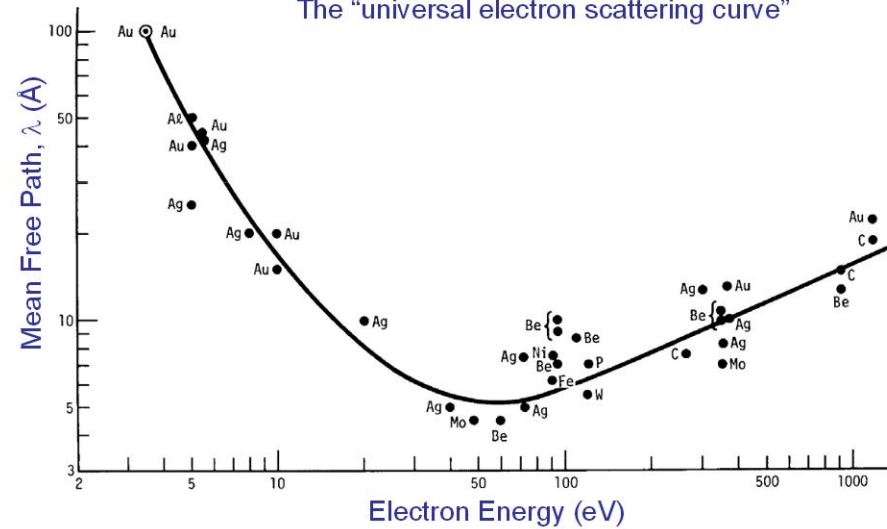



MAX-PLANCK-GESELLSCHAFT

# Dip & Pull

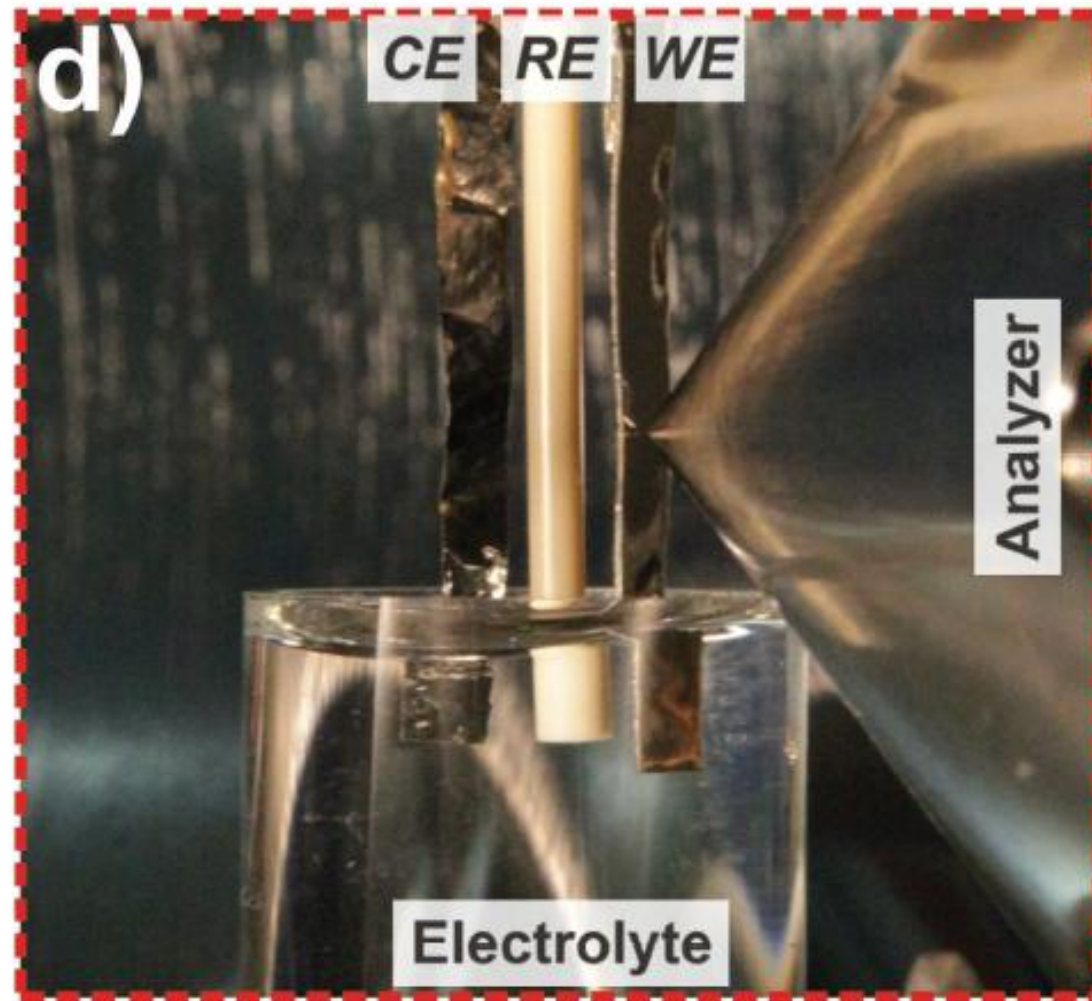



# New design: HPXPS cell

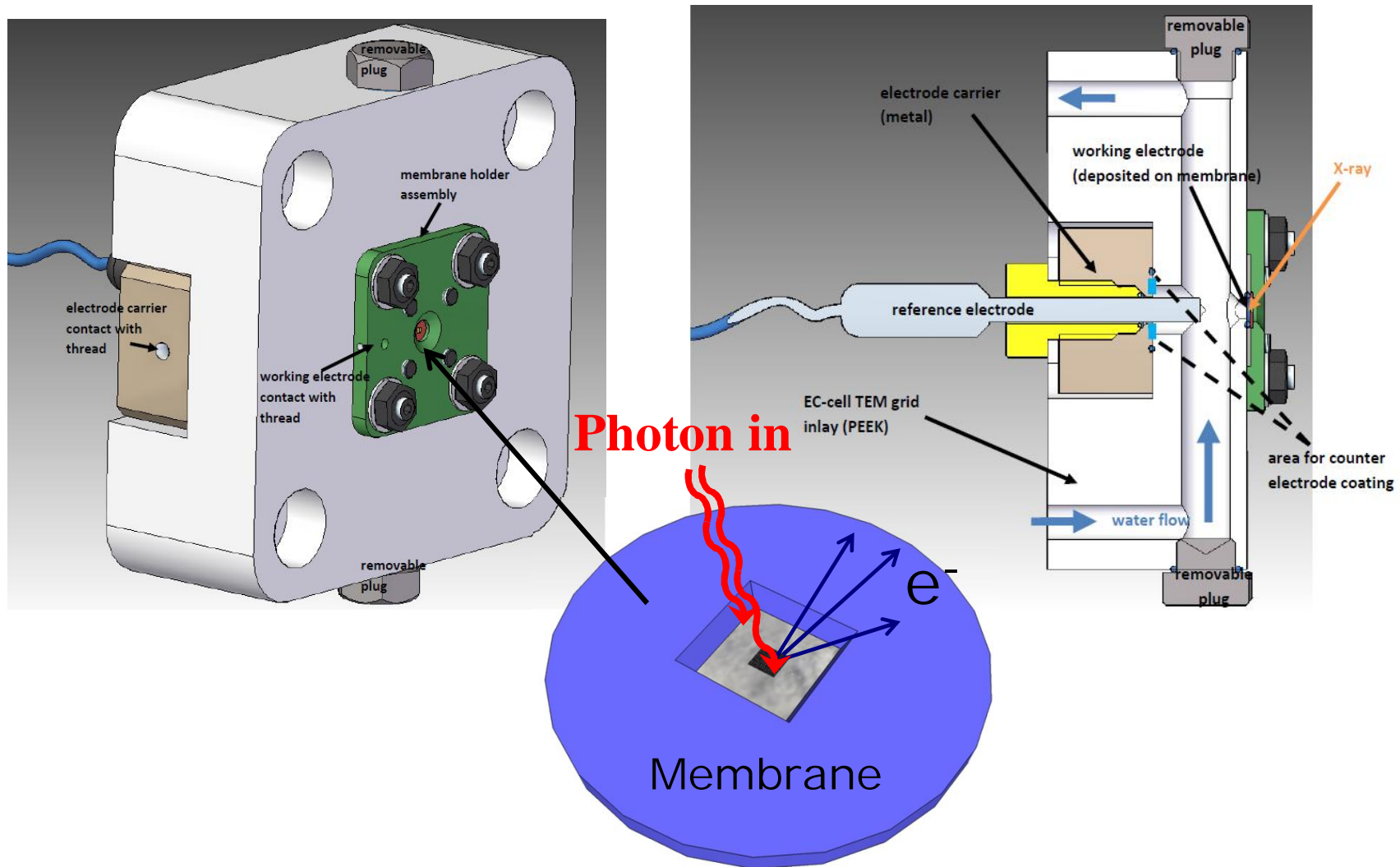



MAX-PLANCK-GESELLSCHAFT

# Membrane grid

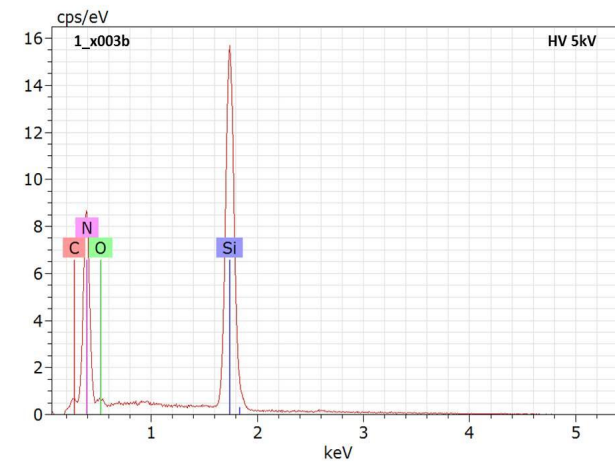
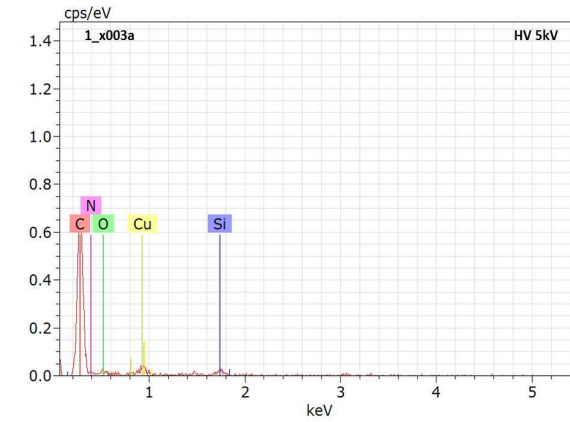
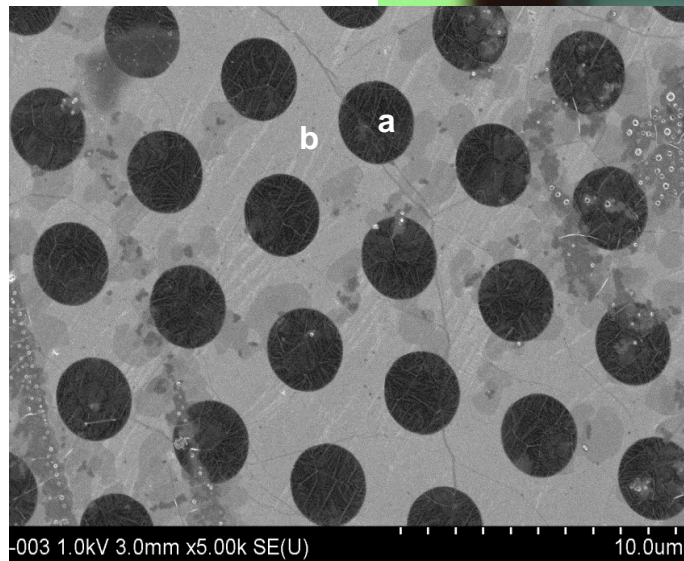
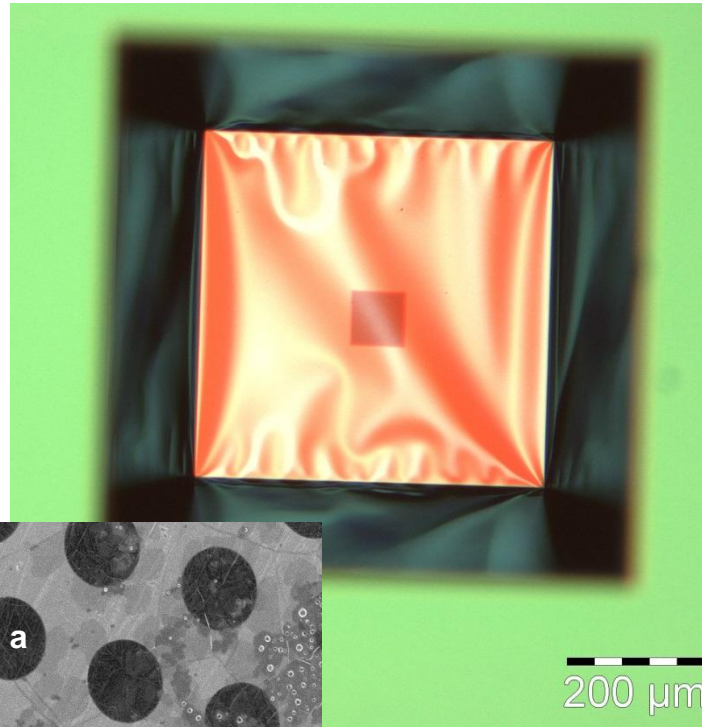



MAX-PLANCK-GESELLSCHAFT

# Stability

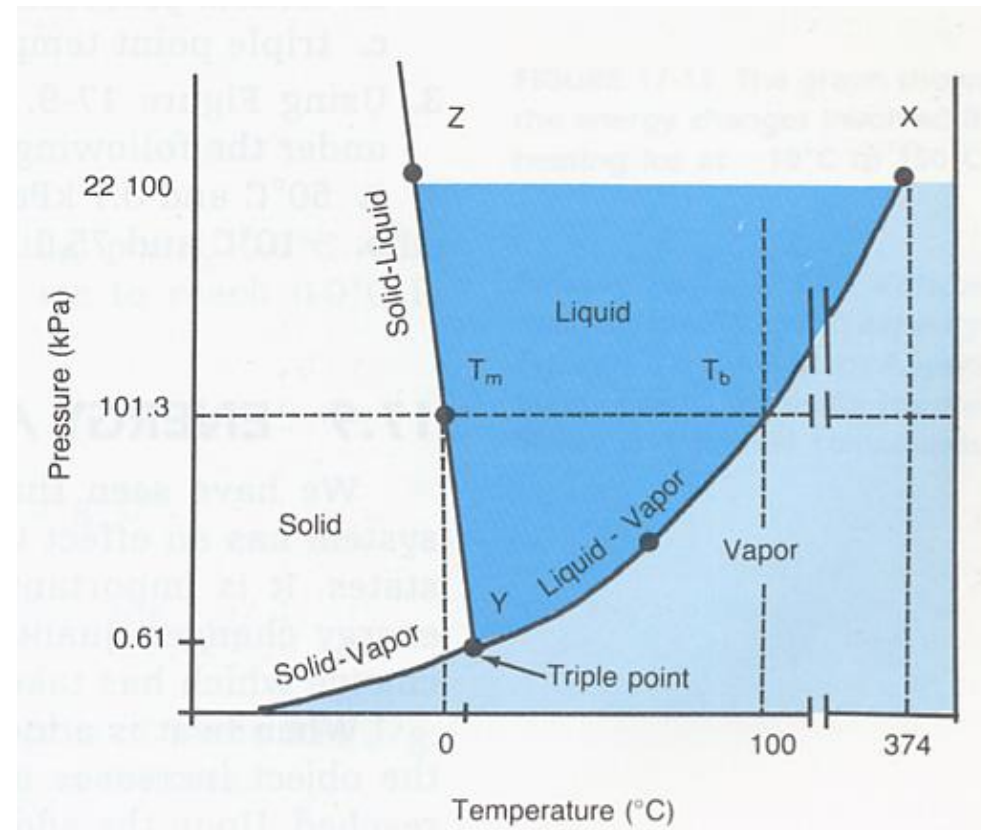
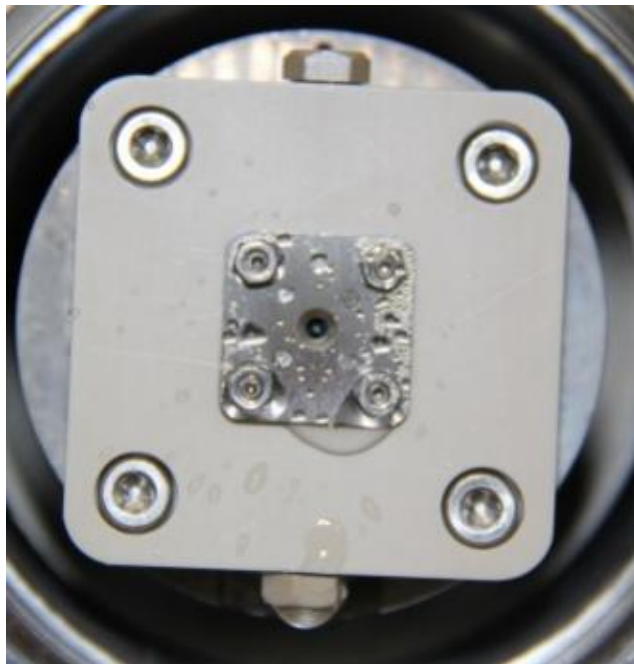



MAX-PLANCK-GESELLSCHAFT

# BLG coverage rate > 99%



Successful 08/2014: BLG covered >99%,  $10^{-7}$  mbar in H<sub>2</sub>O

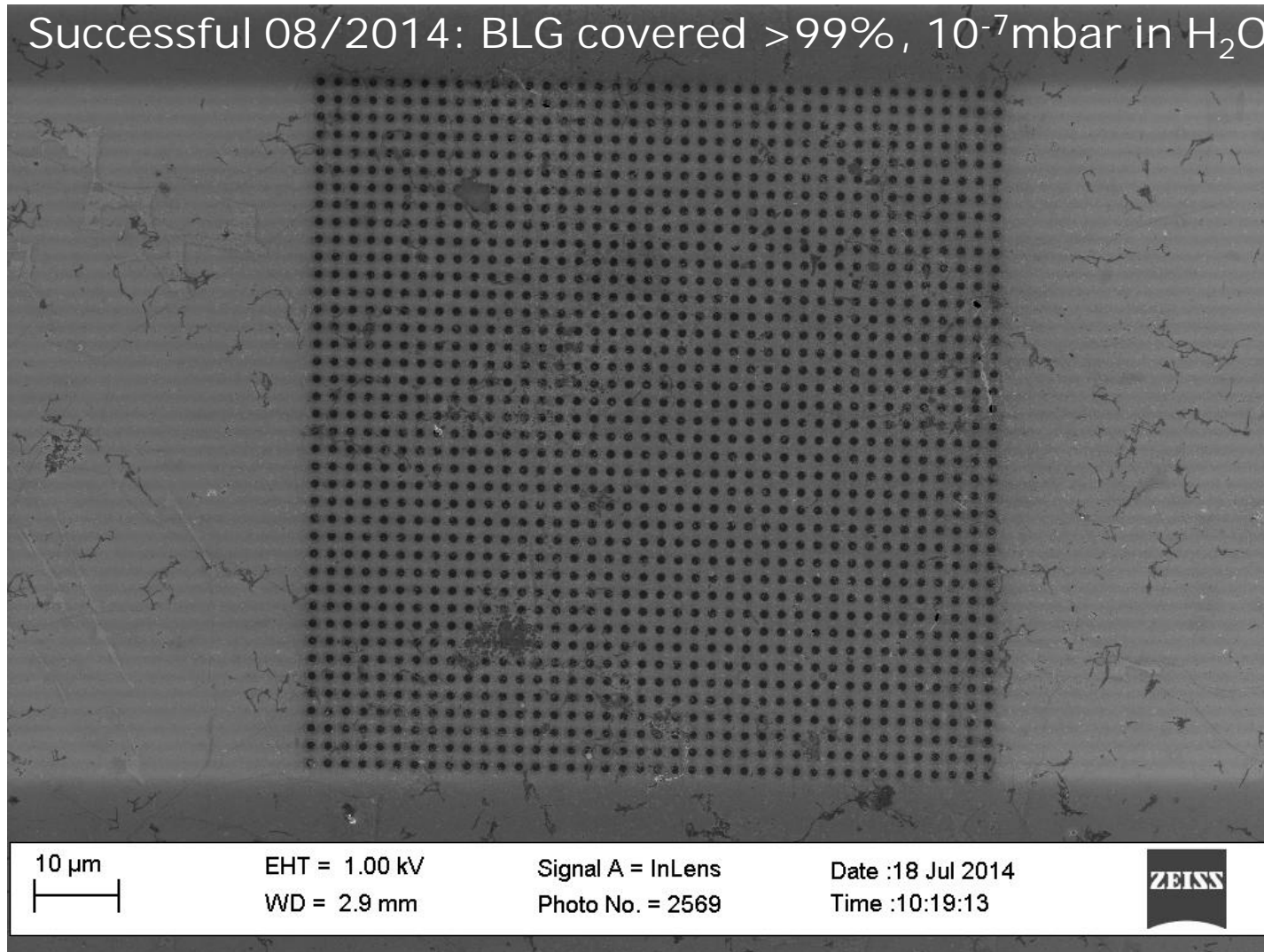



# Graphene membrane

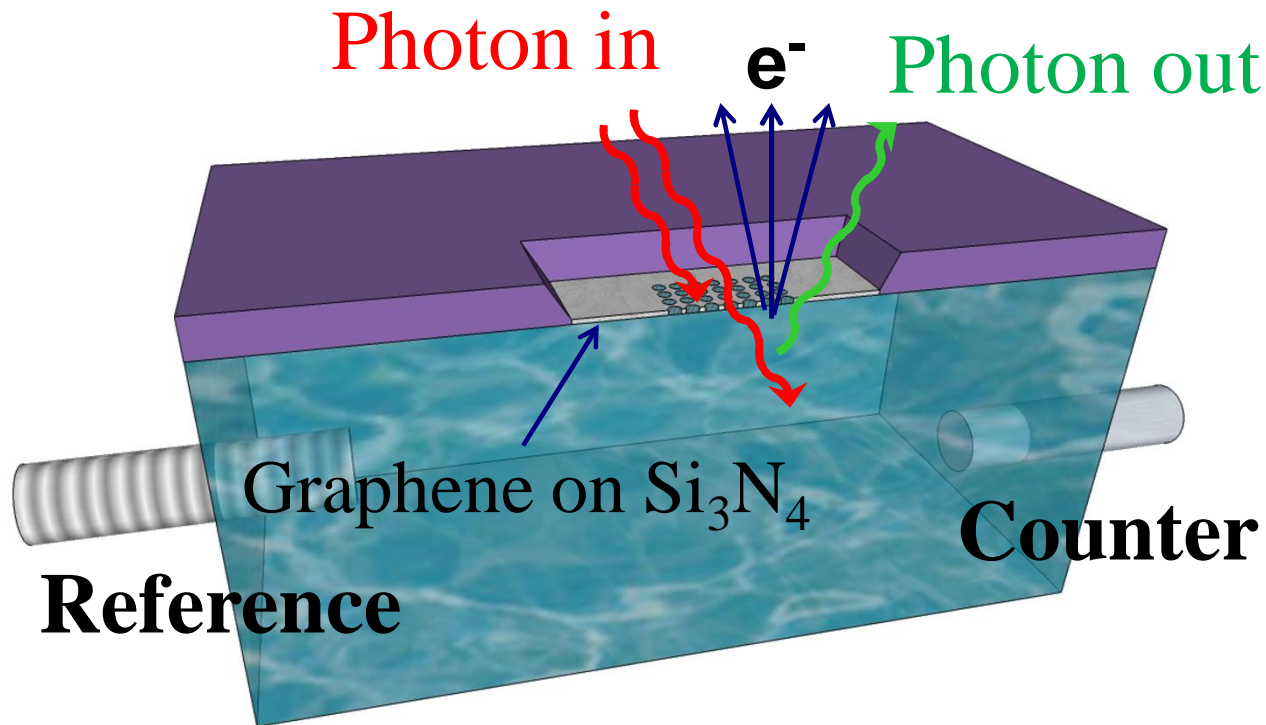
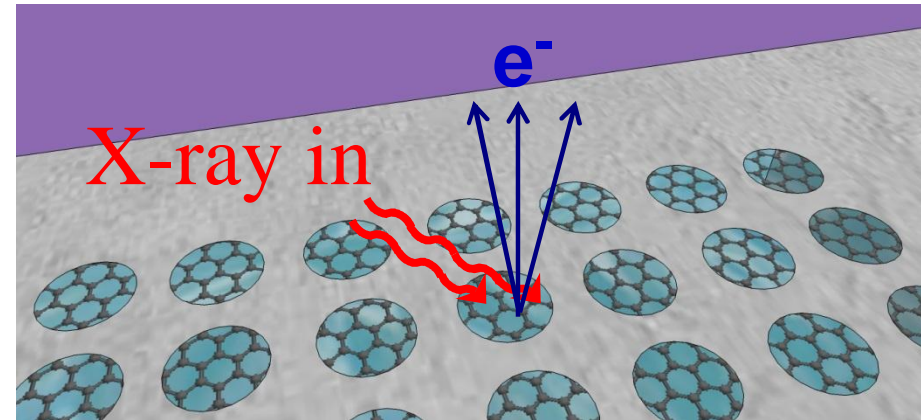



# EC module with the HPXPS cell

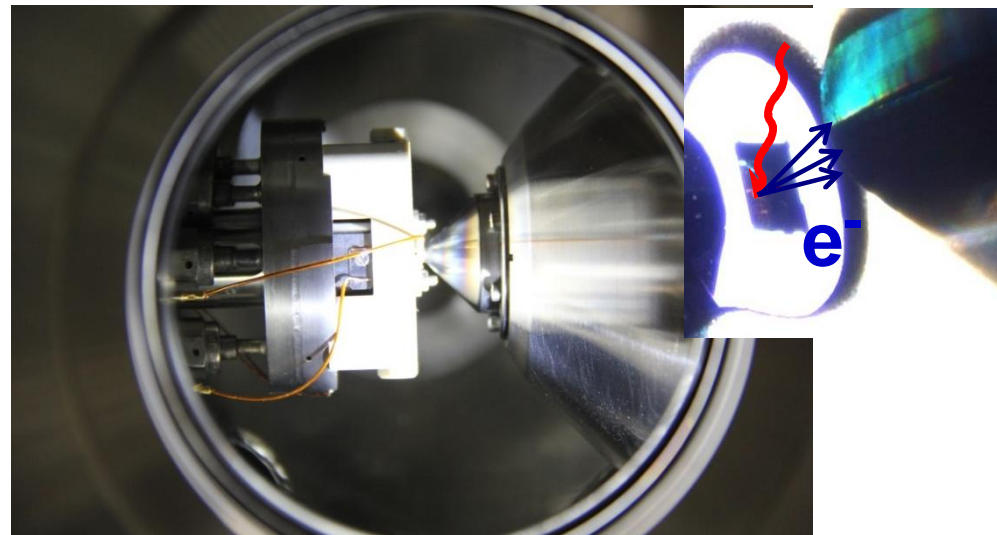
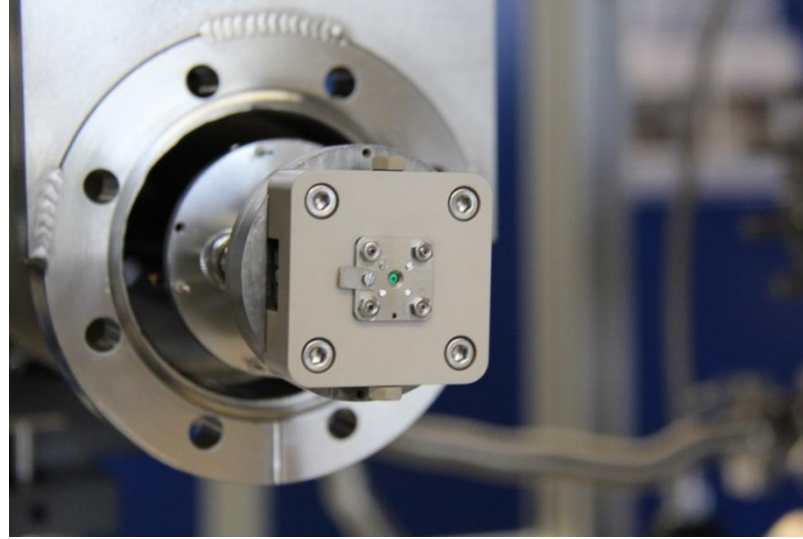
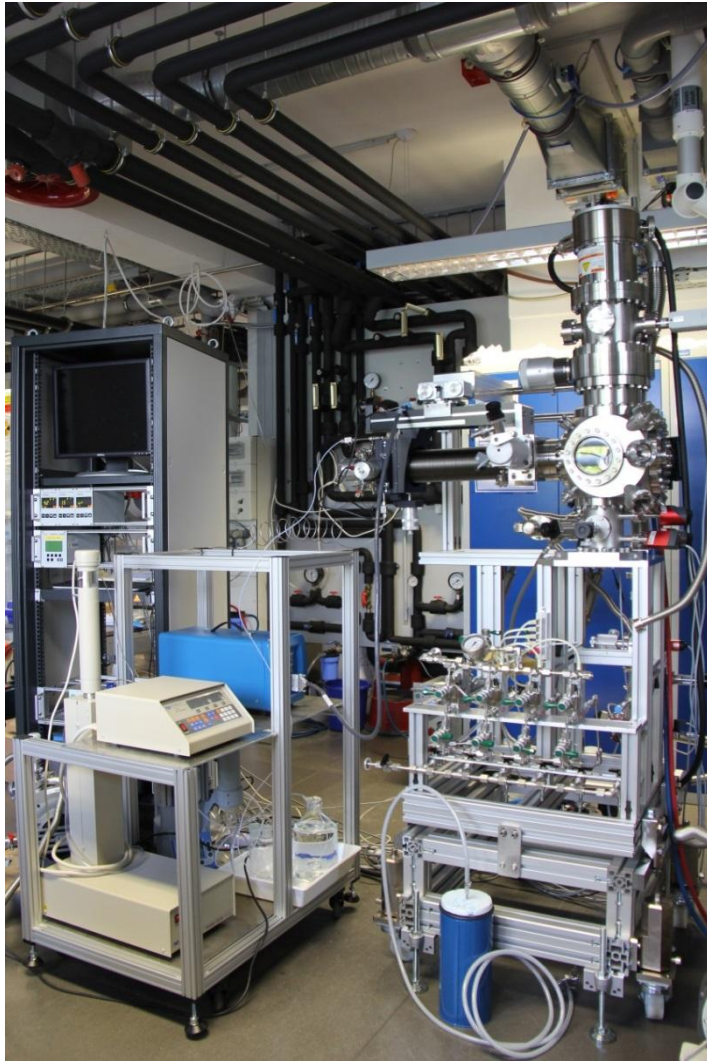



MAX-PLANCK-GESELLSCHAFT

# Pd UHV: Transmission test

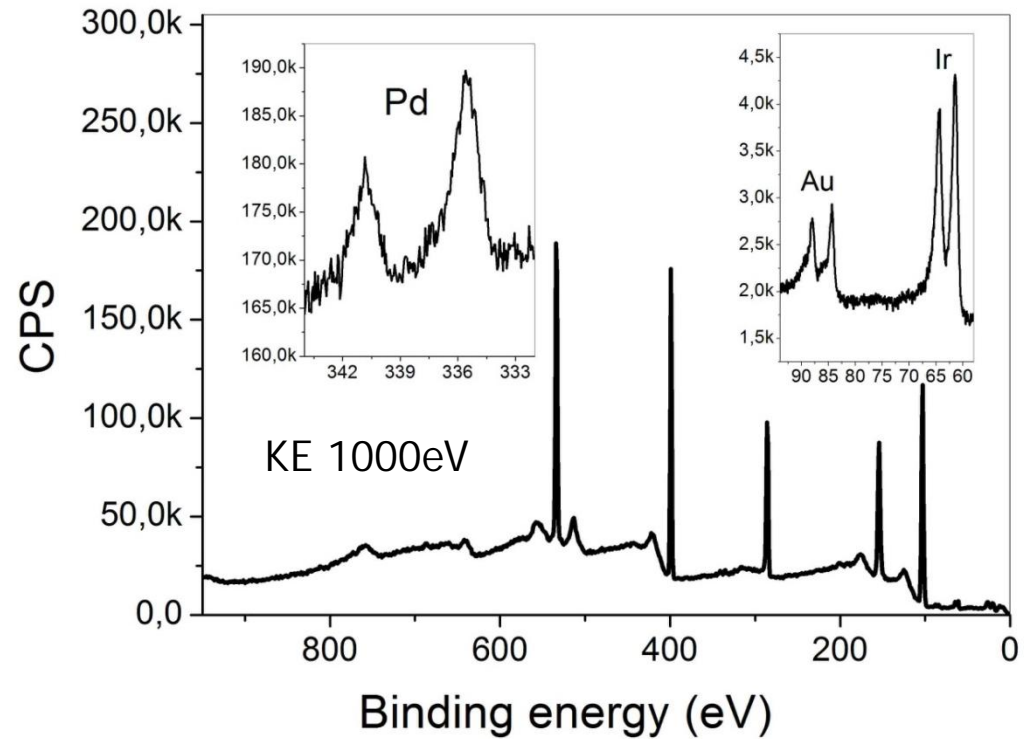
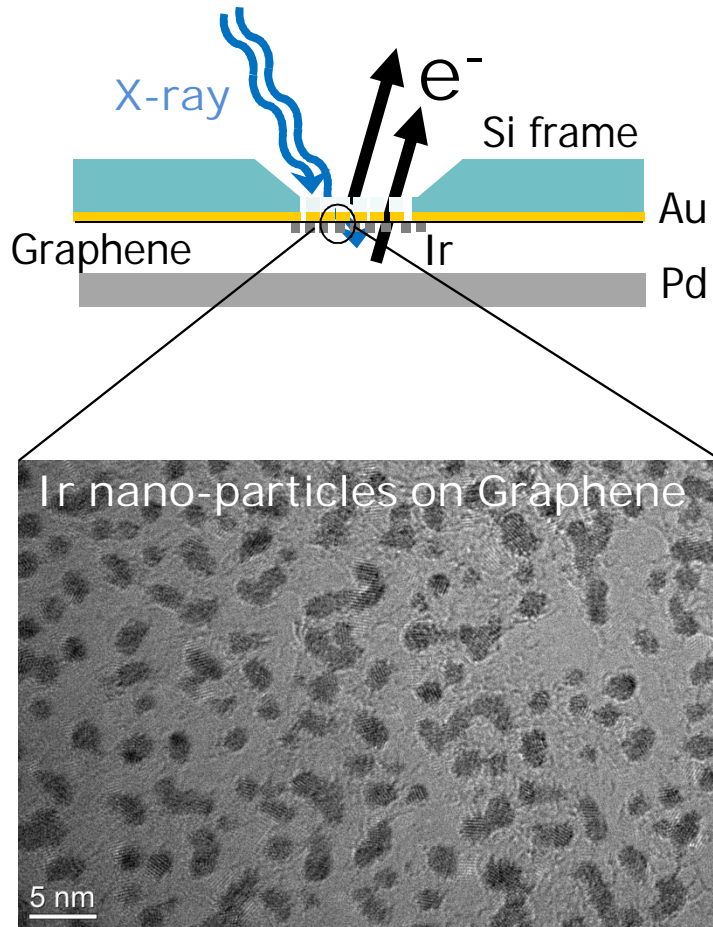

Verena Pfeifer, Juan  
Vélasco



# Cell filled with DI-water

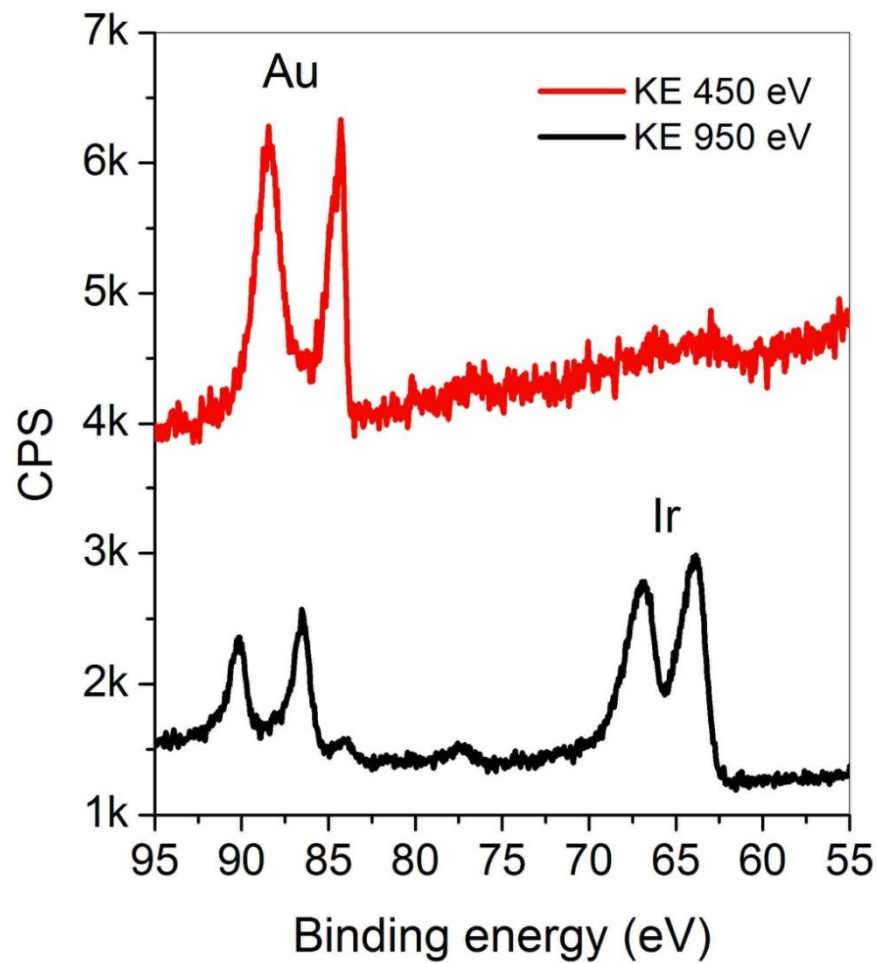
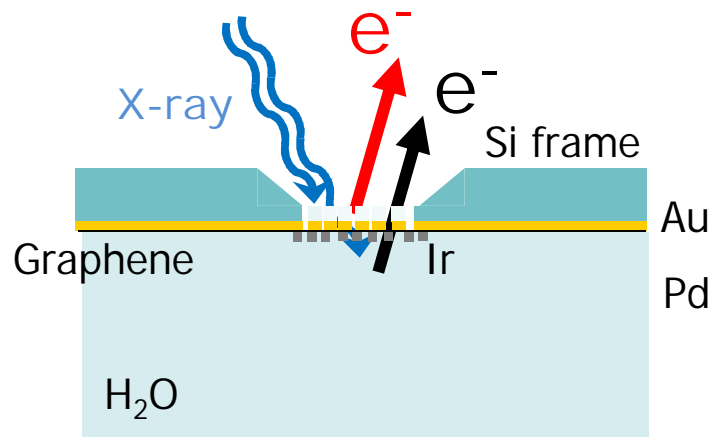

Verena Pfeifer, Juan Vélasco



# Cell filled with 10mM KOH

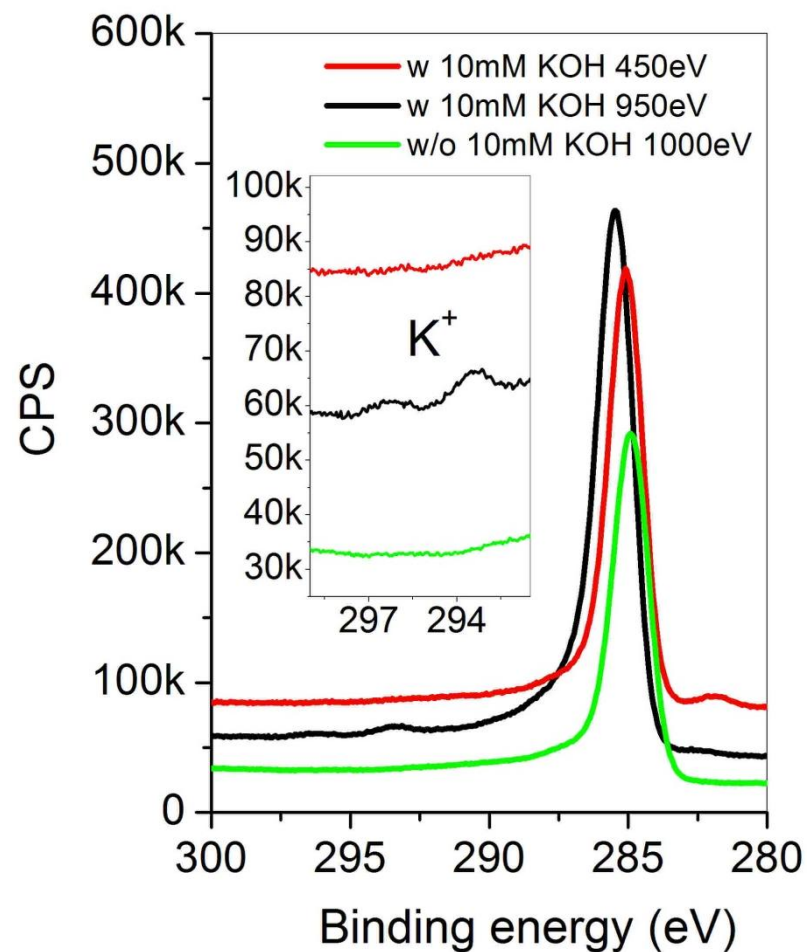
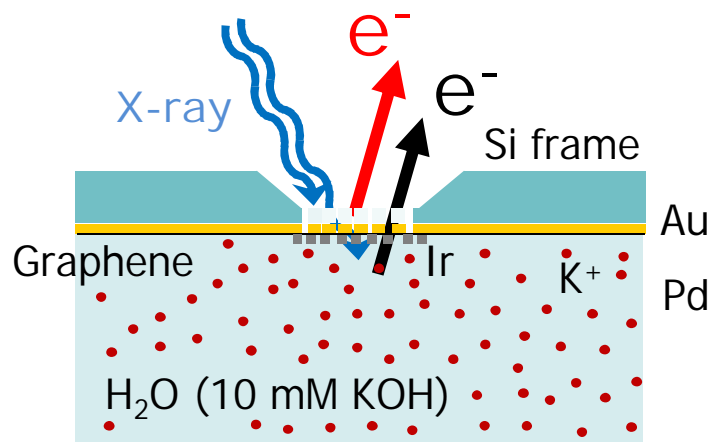

Verena Pfeifer, Juan Vélasco



MAX-PLANCK-GESELLSCHAFT

# Electroplating (4 mM $\text{CoSO}_4$ )

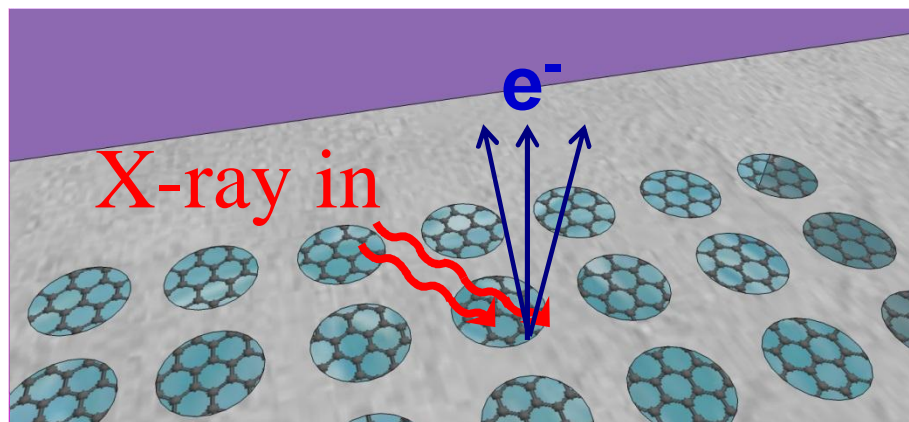

■ Metall electroplated (Co)

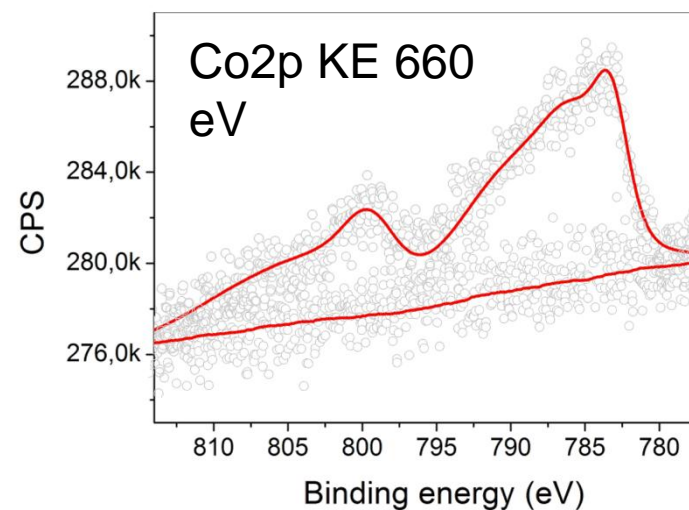
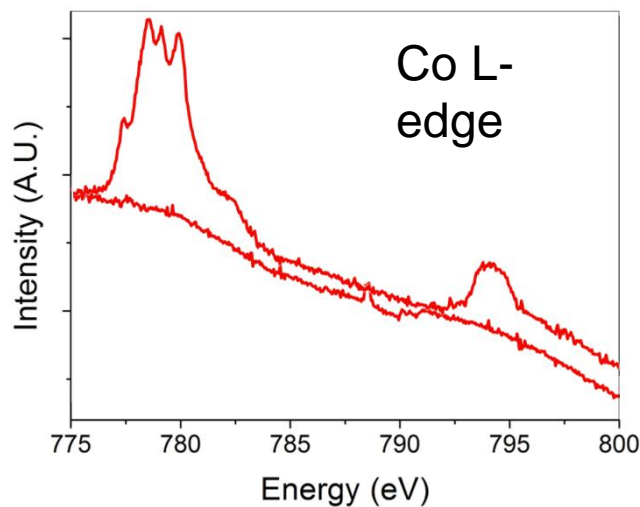
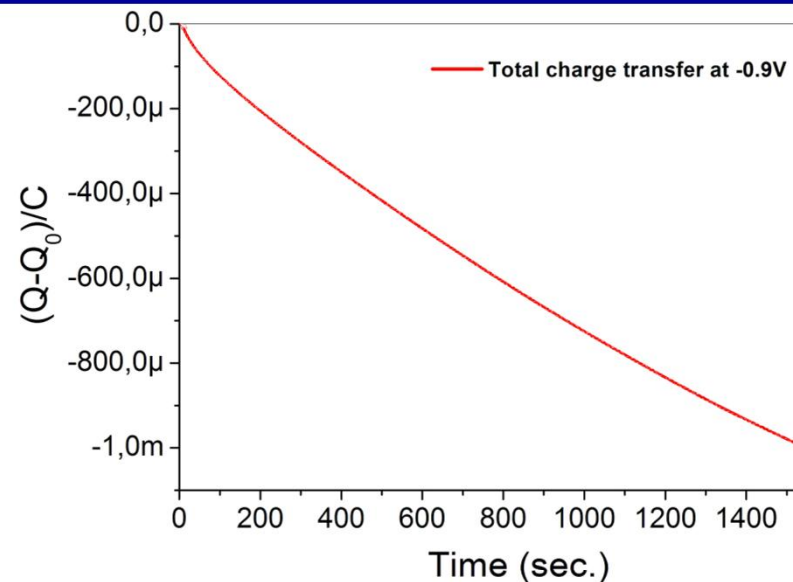

# Anchorage of Co on Graphene

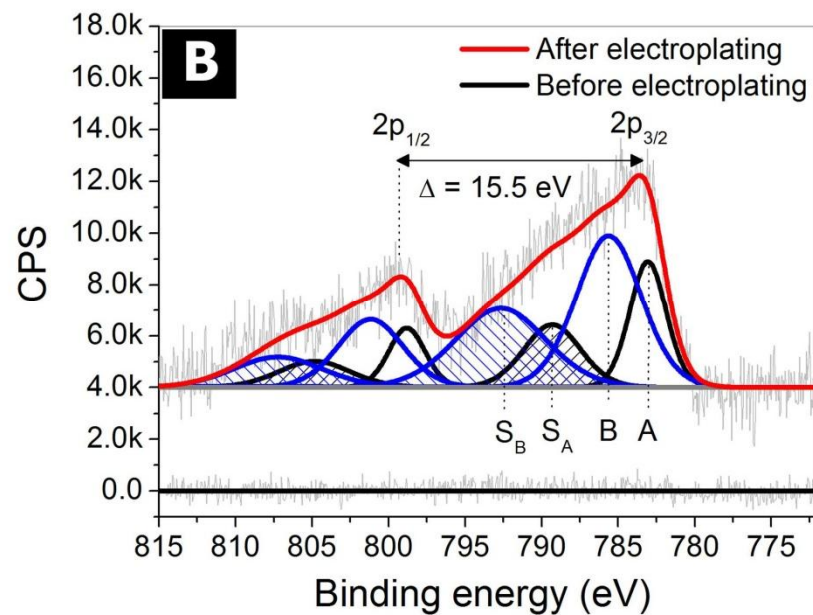
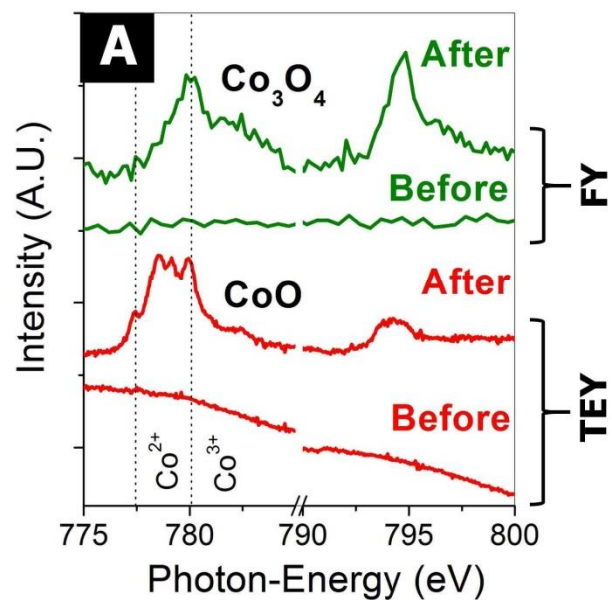

Juan Vélasco et al. Angew. Chemie 2015

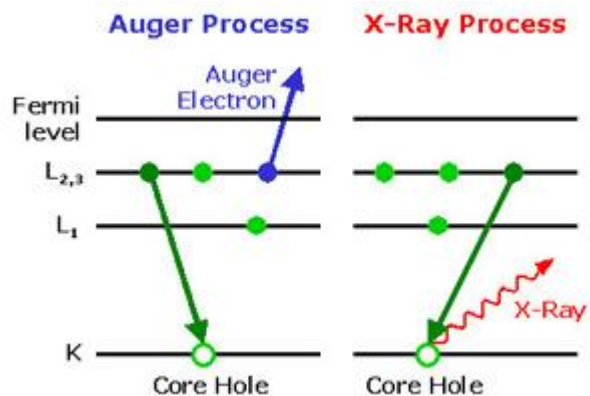

## Summary

---

core states  
atom specific  
quantitative  
complex final state effects  
chemical shift concept  
theoretically difficult accessible  
can be applied in the mbar range  
surface sensitive  
depth profiling

# Literature

---

1. W. Göpel, Chr. Ziegler: **Struktur der Materie: Grundlagen, Mikroskopie und Spektroskopie**, Teubner Verlagsgesellschaft, Stuttgart-Leipzig, 1991
2. M. Henzler, W. Göpel: **Oberflächenphysik des Festkörpers**, Teubner Verlagsgesellschaft, Stuttgart-Leipzig, 1991
3. W. Göpel, Chr. Ziegler : **Einführung in die Materialwissenschaften**, Teubner Verlagsgesellschaft, Stuttgart-Leipzig, 1996
4. D. Briggs, M. P. Seah: **Practical Surface Analysis, Volume 1: Auger and X-Ray Photoelectron Spectroscopy**, 2. Auflage, John Wiley & Sons, Chichester, 1990
5. C. D. Wagner, W. M. Riggs, L. E. Davis, J. F. Moulder, G. E. Muilenberg: **Handbook of X-Ray Photoelectron Spectroscopy**, Physical Electronics Division, Perkin-Elmer Corporation, Eden Prairie, Minnesota, 1979
6. H. Lüth: **Surfaces and Interfaces of Solid Materials**, 3. Auflage, Springer Verlag, Berlin, 1995
7. G. Ertl, J. Küppers: **Low Energy Electrons and Surface Chemistry**, VCH Verlagsgesellschaft, Weinheim, 1985
8. K. Siegbahn, C. Nording et al.: **ESCA Applied to Free Molecules**, North-Holland, Amsterdam, 1971
9. M. Cardona, L. Ley: **Photoemission of Solids**, Topics in Applied Physics, Band 26 und 27, Springer Berlin, 1978
10. M. Grasserbauer, H. J. Dudek, M. F. Ebel: **Angewandte Oberflächenanalyse mit SIMS, AES und XPS**, Springer Berlin, 1979
11. D. Briggs and J. T. Grant: **Surface Analysis by Auger and Photoelectron Spectroscopy**, Surface Spectra and IM Publications 2003