

03/09/2020
Morning



Aakash

Medical | IIT-JEE | Foundations

(Divisions of Aakash Educational Services Limited)

Regd. Office : Aakash Tower, 8, Pusa Road, New Delhi-110005

Ph.: 011-47623456 Fax : 011-47623472

Time : 3 hrs.

Questions & Answers

M.M. : 300

for

JEE (MAIN)-2020 (Online) Phase-2

(Physics, Chemistry and Mathematics)

Important Instructions :

1. The test is of **3 hours** duration.
2. The Test Booklet consists of **75** questions. The maximum marks are **300**.
3. There are **three** parts in the question paper A, B, C consisting of **Physics, Chemistry** and **Mathematics** having 25 questions in each part of equal weightage. Each part has two sections.
 - (i) **Section-I** : This section contains 20 multiple choice questions which have only one correct answer. Each question carries **4 marks** for correct answer and **-1 mark** for wrong answer.
 - (ii) **Section-II** : This section contains 5 SA type questions. The answer to each of the questions is a numerical value. Each question carries **4 marks** for correct answer and there is no negative marking for wrong answer.

PART-A : PHYSICS

SECTION - I

Multiple Choice Questions: This section contains 20 multiple choice questions. Each question has 4 choices (1), (2), (3) and (4), out of which **ONLY ONE** is correct.

Choose the correct answer :

- A 750 Hz, 20 V (rms) source is connected to a resistance of 100 Ω, an inductance of 0.1803 H and a capacitance of 10 μF all in series. The time in which the resistance (heat capacity 2 J/°C) will get heated by 10°C. (assume no loss of heat to the surroundings) is close to
 (1) 348 s (2) 418 s
 (3) 245 s (4) 365 s

Answer (1)

- An elliptical loop having resistance R, of semi major axis a, and semi minor axis b is placed in a magnetic field as shown in the figure. If the loop is rotated about the x-axis with angular frequency ω, the average power loss in the loop due to Joule heating is

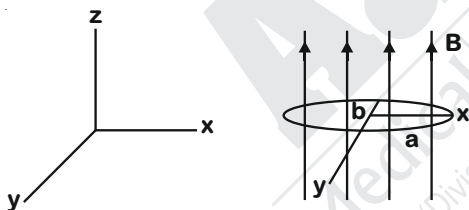

- $\frac{\pi abB\omega}{R}$
- $\frac{\pi^2 a^2 b^2 B^2 \omega^2}{2R}$
- Zero
- $\frac{\pi^2 a^2 b^2 B^2 \omega^2}{R}$

Answer (2)

- A uniform thin rope of length 12 m and mass 6 kg hangs vertically from a rigid support and a block of mass 2 kg is attached to its free end. A transverse short wavetrain of wavelength 6 cm is produced at the lower end of the rope. What is the wavelength of the wavetrain (in cm) when it reaches the top of the rope?
 (1) 6 (2) 3
 (3) 12 (4) 9

Answer (3)

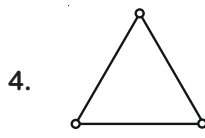

4. Consider a gas of triatomic molecules. The molecules are assumed to be triangular and made of massless rigid rods whose vertices are occupied by atoms. The internal energy of a mole of the gas at temperature T is

- 3RT
- $\frac{9}{2}RT$
- $\frac{3}{2}RT$
- $\frac{5}{2}RT$

Answer (1)

- When a diode is forward biased, it has a voltage drop of 0.5 V. The safe limit of current through the diode is 10 mA. If a battery of emf 1.5 V is used in the circuit, the value of minimum resistance to be connected in series with the diode so that the current does not exceed the safe limit is

- 50 Ω
- 200 Ω
- 300 Ω
- 100 Ω

Answer (4)

- A satellite is moving in a low nearly circular orbit around the earth. Its radius is roughly equal to that of the earth's radius R_e . By firing rockets attached to it, its speed is instantaneously increased in the direction of its

motion so that it become $\sqrt{\frac{3}{2}}$ times larger. Due

to this the farthest distance from the centre of the earth that the satellite reaches is R. Value of R is

- $3R_e$
- $4R_e$
- $2.5R_e$
- $2R_e$

Answer (1)

7. When the wavelength of radiation falling on a metal is changed from 500 nm to 200 nm, the maximum kinetic energy of the photoelectrons becomes three times larger. The work function of the metal is close to
- (1) 0.52 eV (2) 1.02 eV
(3) 0.61 eV (4) 0.81 eV

Answer (3)

8. A charged particle carrying charge $1 \mu\text{C}$ is moving with velocity $(2\hat{i} + 3\hat{j} + 4\hat{k}) \text{ ms}^{-1}$. If an external magnetic field of $(5\hat{i} + 3\hat{j} - 6\hat{k}) \times 10^{-3} \text{ T}$ exists in the region where the particle is moving then the force on the particle is $\vec{F} \times 10^{-9} \text{ N}$. The vector \vec{F} is
- (1) $-3.0\hat{i} + 3.2\hat{j} - 0.9\hat{k}$
(2) $-300\hat{i} + 320\hat{j} - 90\hat{k}$
(3) $-0.30\hat{i} + 0.32\hat{j} - 0.09\hat{k}$
(4) $-30\hat{i} + 32\hat{j} - 9\hat{k}$

Answer (4)

9. Moment of inertia of a cylinder of mass M , length L and radius R about an axis passing through its centre and perpendicular to the axis of the cylinder is $I = M \left(\frac{R^2}{4} + \frac{L^2}{12} \right)$. If such a cylinder is to be made for a given mass of a material, the ratio L/R for it to have minimum possible I is
- (1) $\sqrt{\frac{2}{3}}$
(2) $\frac{2}{3}$
(3) $\frac{3}{2}$
(4) $\sqrt{\frac{3}{2}}$

Answer (4)

10. Two isolated conducting spheres S_1 and S_2 of radius $\frac{2}{3}R$ and $\frac{1}{3}R$ have $12 \mu\text{C}$ and $-3 \mu\text{C}$ charges, respectively, and are at a large distance from each other. They are now connected by a conducting wire. A long time after this is done the charges on S_1 and S_2 are respectively
- (1) $4.5 \mu\text{C}$ on both
(2) $+4.5 \mu\text{C}$ and $-4.5 \mu\text{C}$
(3) $6 \mu\text{C}$ and $3 \mu\text{C}$
(4) $3 \mu\text{C}$ and $6 \mu\text{C}$

Answer (3)

11. A block of mass $m = 1 \text{ kg}$ slides with velocity $v = 6 \text{ m/s}$ on a frictionless horizontal surface and collides with a uniform vertical rod and sticks to it as shown. The rod is pivoted about O and swings as a result of the collision making angle θ before momentarily coming to rest. If the rod has mass $M = 2 \text{ kg}$ and length $l = 1 \text{ m}$, the value of θ is approximately (take $g = 10 \text{ m/s}^2$)

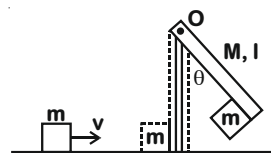

- (1) 49° (2) 55°
(3) 63° (4) 69°

Answer (3)

12. Pressure inside two soap bubbles are 1.01 and 1.02 atmosphere, respectively. The ratio of their volumes is
- (1) $2 : 1$ (2) $0.8 : 1$
(3) $4 : 1$ (4) $8 : 1$

Answer (4)

13. In a Young's double slit experiment, light of 500 nm is used to produce an interference pattern. When the distance between the slits is 0.05 mm, the angular width (in degree) of the fringes formed on the distance screen is close to
- (1) 0.17° (2) 1.7°
(3) 0.57° (4) 0.07°

Answer (3)

14. In a radioactive material, fraction of active material remaining after time t is $9/16$. The fraction that was remaining after $t/2$ is

- (1) $\frac{3}{4}$
(2) $\frac{4}{5}$
(3) $\frac{3}{5}$
(4) $\frac{7}{8}$

Answer (1)

15. In the circuit shown in the figure, the total charge is $750 \mu\text{C}$ and the voltage across capacitor C_2 is 20 V . Then the charge on capacitor C_2 is

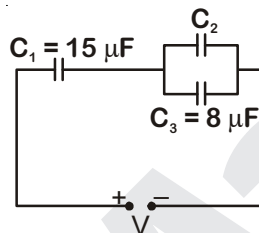

- (1) $650 \mu\text{C}$
(2) $590 \mu\text{C}$
(3) $160 \mu\text{C}$
(4) $450 \mu\text{C}$

Answer (2)

16. Magnitude of magnetic field (in SI units) at the centre of a hexagonal shape coil of side 10 cm , 50 turns and carrying current I (Ampere) in

units of $\frac{\mu_0 I}{\pi}$ is

- (1) $500\sqrt{3}$
(2) $250\sqrt{3}$
(3) $50\sqrt{3}$
(4) $5\sqrt{3}$

Answer (1)

17. A balloon filled with helium (32°C and 1.7 atm.) bursts. Immediately afterwards the expansion of helium can be considered as

- (1) Irreversible adiabatic
(2) Reversible adiabatic
(3) Irreversible isothermal
(4) Reversible isothermal

Answer (1)

18. Using screw gauge of pitch 0.1 cm and 50 divisions on its circular scale, the thickness of an object is measured. It should correctly be recorded as

- (1) 2.124 cm
(2) 2.123 cm
(3) 2.125 cm
(4) 2.121 cm

Answer (1)

19. Model a torch battery of length l to be made up of a thin cylindrical bar of radius ' a ' and a concentric thin cylindrical shell of radius ' b ' filled in between with an electrolyte of resistivity ρ (see figure). If the battery is connected to a resistance of value R , the maximum Joule heating in R will take place for

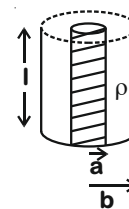

(1) $R = \frac{\rho}{\pi l} \ln\left(\frac{b}{a}\right)$

(2) $R = \frac{2\rho}{\pi l} \ln\left(\frac{b}{a}\right)$

(3) $R = \frac{\rho}{2\pi l} \ln\left(\frac{b}{a}\right)$

(4) $R = \frac{\rho}{2\pi l} \left(\frac{b}{a}\right)$

Answer (3)

20. The magnetic field of a plane electromagnetic wave is

$$\vec{B} = 3 \times 10^{-8} \sin[200\pi(y + ct)] \hat{i} \text{ T}$$

where $c = 3 \times 10^8 \text{ ms}^{-1}$ is the speed of light.

The corresponding electric field is

- (1) $\vec{E} = -9 \sin[200\pi(y + ct)] \hat{k} \text{ V/m}$
 (2) $\vec{E} = 9 \sin[200\pi(y + ct)] \hat{k} \text{ V/m}$
 (3) $\vec{E} = -10^{-6} \sin[200\pi(y + ct)] \hat{k} \text{ V/m}$
 (4) $\vec{E} = 3 \times 10^{-8} \sin[200\pi(y + ct)] \hat{k} \text{ V/m}$

Answer (1)

SECTION - II

Numerical Value Type Questions: This section contains 5 questions. The answer to each question is a NUMERICAL VALUE. For each question, enter the correct numerical value (in decimal notation, truncated/rounded off to the second decimal place; e.g. 06.25, 07.00, -00.33, -00.30, 30.27, -27.30) using the mouse and the on-screen virtual numeric keypad in the place designated to enter the answer.

21. A person of 80 kg mass is standing on the rim of a circular platform of mass 200 kg rotating about its axis at 5 revolutions per minute (rpm). The person now starts moving towards the centre of the platform. What will be the rotational speed (in rpm) of the platform when the person reaches its centre _____.

Answer (9)

22. An observer can see through a small hole on the side of a jar (radius 15 cm) at a point at height of 15 cm from the bottom (see figure). The hole is at a height of 45 cm. When the jar is filled with a liquid up to a height of 30 cm the same observer can see the edge at the bottom of the jar. If the refractive index of the liquid is $N/100$, where N is an integer, the value of N is _____.

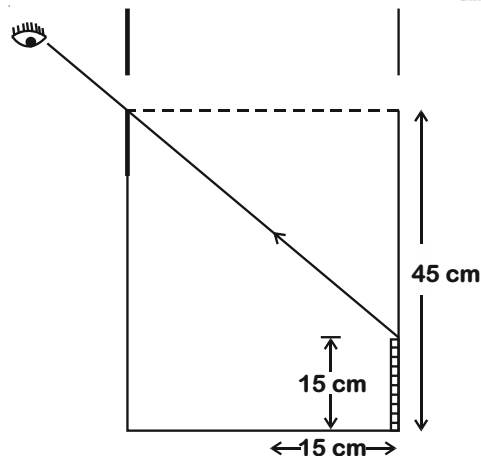

Answer (158)

23. A bakelite beaker has volume capacity of 500 cc at 30°C . When it is partially filled with V_m volume (at 30°C) of mercury, it is found that the unfilled volume of the beaker remains constant as temperature is varied. If $\gamma_{(\text{beaker})} = 6 \times 10^{-6} \text{ }^\circ\text{C}^{-1}$ and $\gamma_{(\text{mercury})} = 1.5 \times 10^{-4} \text{ }^\circ\text{C}^{-1}$, where γ is the coefficient of volume expansion, then V_m (in cc) is close to _____.

Answer (20)

24. A cricket ball of mass 0.15 kg is thrown vertically up by a bowling machine so that it rises to a maximum height of 20 m after leaving the machine. If the part pushing the ball applies a constant force F on the ball and moves horizontally a distance of 0.2 m while launching the ball, the value of F (in N) is ($g = 10 \text{ ms}^{-2}$) _____.

Answer (150)

25. When a long glass capillary tube of radius 0.015 cm is dipped in a liquid, the liquid rises to a height of 15 cm within it. If the contact angle between the liquid and glass is close to 0° , the surface tension of the liquid, in milliNewton m^{-1} , is $[\rho_{(\text{liquid})} = 900 \text{ kgm}^{-3}, g = 10 \text{ ms}^{-2}]$ (Give answer in closest integer) _____.

Answer (101)



PART-B : CHEMISTRY

SECTION - I

Multiple Choice Questions: This section contains 20 multiple choice questions. Each question has 4 choices (1), (2), (3) and (4), out of which **ONLY ONE** is correct.

Choose the correct answer :

1. The mechanism of S_N1 reaction is given as

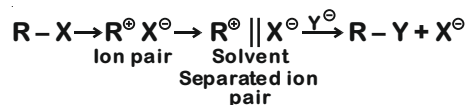

A student writes general characteristics based on the given mechanism as

- The reaction is favoured by weak nucleophiles.
- R^{\oplus} would be easily formed if the substituents are bulky.
- The reaction is accompanied by racemization.
- The reaction is favoured by non-polar solvents.

Which observations are correct?

- (b) and (d)
- (a) and (c)
- (a) and (b)
- (a), (b) and (c)

Answer (4)

2. Which one of the following compounds possesses the most acidic hydrogen?

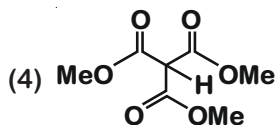
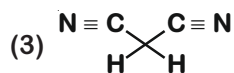
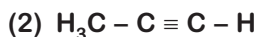
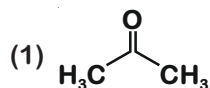

Answer (4)

3. Aqua regia is used for dissolving noble metals (Au, Pt, etc.). The gas evolved in this process is

- NO
- N_2
- N_2O_5
- N_2O_3

Answer (1)

4. Henry's constant (in kbar) for four gases α , β , γ and δ in water at 298 K is given below

	α	β	γ	δ
K_H	50	2	2×10^{-5}	0.5

(density of water = 10^3 kg m^{-3} at 298 K)

This table implies that

- The pressure of a 55.5 molal solution of γ is 1 bar
- Solubility of γ at 308 K is lower than at 298 K
- α has the highest solubility in water at a given pressure
- The pressure of a 55.5 molal solution of δ is 250 bar

Answer (2)

5. The atomic number of the element unnilennium is

- 109
- 119
- 102
- 108

Answer (1)

6. An acidic buffer is obtained on mixing

- 100 mL of 0.1 M HCl and 200 mL of 0.1 M NaCl
- 100 mL of 0.1 M HCl and 200 mL of 0.1 M CH_3COONa
- 100 mL of 0.1 M CH_3COOH and 100 mL of 0.1 M NaOH
- 100 mL of 0.1 M CH_3COOH and 200 mL of 0.1 M NaOH

Answer (2)

7. An organic compound [A], molecular formula $C_{10}H_{20}O_2$ was hydrolyzed with dilute sulphuric acid to give a carboxylic acid [B] and an alcohol [C]. Oxidation of [C] with $CrO_3 - H_2SO_4$ produced [B]. Which of the following structures are not possible for [A]?

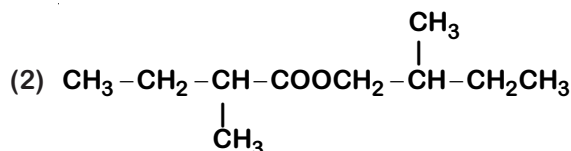
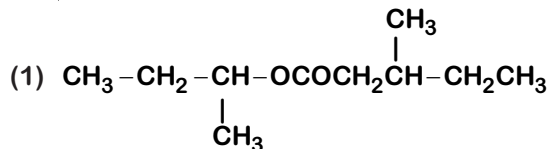

- (3) $(\text{CH}_3)_3\text{C}-\text{C}-\text{COOCH}_2\text{C}(\text{CH}_3)_3$
 (4) $\text{CH}_3\text{CH}_2\text{CH}_2\text{COOCH}_2\text{CH}_2\text{CH}_2\text{CH}_3$

Answer (1,4)

8. The antifertility drug "Novestrol" can react with

- (1) Br_2/water ; ZnCl_2/HCl ; FeCl_3
 (2) ZnCl_2/HCl ; FeCl_3 ; Alcoholic HCN
 (3) Br_2/water ; ZnCl_2/HCl ; NaOCl
 (4) Alcoholic HCN; NaOCl; ZnCl_2/HCl

Answer (1)

9. If the boiling point of H_2O is 373 K, the boiling point of H_2S will be

- (1) less than 300 K
 (2) more than 373 K
 (3) equal to 373 K
 (4) greater than 300 K but less than 373 K

Answer (1)

10. It is true that

- (1) A zero order reaction is a single step reaction
 (2) A zero order reaction is a multistep reaction
 (3) A first order reaction is always a single step reaction
 (4) A second order reaction is always a multistep reaction

Answer (2)

11. The electronic spectrum of $[\text{Ti}(\text{H}_2\text{O})_6]^{3+}$ shows a single broad peak with a maximum at $20,300\text{ cm}^{-1}$. The crystal field stabilization energy (CFSE) of the complex ion, in kJ mol^{-1} , is

- (1 $\text{kJ mol}^{-1} = 83.7\text{ cm}^{-1}$)
 (1) 145.5
 (2) 97
 (3) 242.5
 (4) 83.7

Answer (2)

12. The complex that can show optical activity

- (1) *cis*- $[\text{Fe}(\text{NH}_3)_2(\text{CN})_4]^-$
 (2) *trans*- $[\text{Cr}(\text{Cl}_2)(\text{ox})_2]^{3-}$
 (3) *trans*- $[\text{Fe}(\text{NH}_3)_2(\text{CN})_4]^-$
 (4) *cis*- $[\text{CrCl}_2(\text{ox})_2]^{3-}$ (ox = oxalate)

Answer (4)

13. Tyndall effect is observed when

- (1) The diameter of dispersed particles is much larger than the wavelength of light used
 (2) The diameter of dispersed particles is similar to the wavelength of light used
 (3) The diameter of dispersed particles is much smaller than the wavelength of light used
 (4) The refractive index of dispersed phase is greater than that of the dispersion medium

Answer (2)

14. In a molecule of pyrophosphoric acid, the number of P – OH, P = O and P – O – P bonds/moiety(ies) respectively are

- (1) 4, 2 and 0
 (2) 4, 2 and 1
 (3) 3, 3 and 3
 (4) 2, 4 and 1

Answer (2)

15. Glycerol is separated in soap industries by

- (1) Fractional distillation
 (2) Differential extraction
 (3) Distillation under reduced pressure
 (4) Steam distillation

Answer (3)

16. Thermal power plants can lead to

- (1) Eutrophication
 (2) Ozone layer depletion
 (3) Blue baby syndrome
 (4) Acid rain

Answer (4)

17. Of the species, NO, NO^+ , NO^{2+} and NO^- , the one with minimum bond strength is

- (1) NO^-
 (2) NO^{2+}
 (3) NO^+
 (4) NO

Answer (1)

18. The Kjeldahl method of Nitrogen estimation fails for which of the following reaction products?

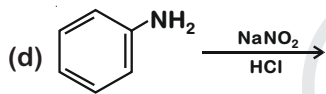
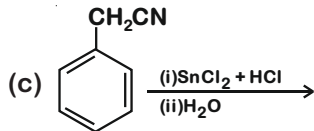
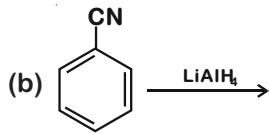
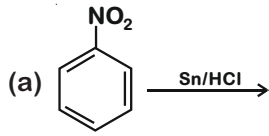

- (1) (a), (c) and (d) (2) (a) and (d)
(3) (c) and (d) (4) (b) and (c)

Answer (3)

19. Which of the following compounds produces an optically inactive compound on hydrogenation?

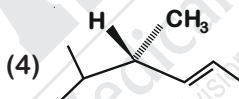
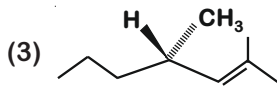
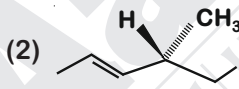
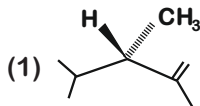

Answer (1)

20. Let C_{NaCl} and C_{BaSO_4} be the conductances (in S) measured for saturated aqueous solutions of NaCl and BaSO_4 , respectively, at a temperature T.

Which of the following is false?

- (1) $C_{\text{BaSO}_4}(T_2) > C_{\text{BaSO}_4}(T_1)$ for $T_2 > T_1$
(2) $C_{\text{NaCl}}(T_2) > C_{\text{NaCl}}(T_1)$ for $T_2 > T_1$
(3) $C_{\text{NaCl}} \gg C_{\text{BaSO}_4}$ at a given T
(4) Ionic mobilities of ions from both salts increase with T.

Answer (3)

SECTION - II

Numerical Value Type Questions: This section contains 5 questions. The answer to each question is a NUMERICAL VALUE. For each question, enter the correct numerical value (in decimal notation, truncated/rounded off to the second decimal place; e.g. 06.25, 07.00, -00.33, -00.30, 30.27, -27.30) using the mouse and the on-screen virtual numeric keypad in the place designated to enter the answer.

21. The volume strength of 8.9 M H_2O_2 solution calculated at 273 K and 1 atm is _____. ($R = 0.0821 \text{ L atm K}^{-1} \text{ mol}^{-1}$) (rounded off to the nearest integer)

Answer (100)

22. An element with molar mass $2.7 \times 10^{-2} \text{ kg mol}^{-1}$ forms a cubic unit cell with edge length 405 pm. If its density is $2.7 \times 10^3 \text{ kg m}^{-3}$, the radius of the element is approximately _____ $\times 10^{-12} \text{ m}$ (to the nearest integer).

Answer (143)

23. The photoelectric current from Na (work function, $w_0 = 2.3 \text{ eV}$) is stopped by the output voltage of the cell



The pH of aq. HCl required to stop the photoelectric current from K ($w_0 = 2.25 \text{ eV}$), all other conditions remaining the same, is _____ $\times 10^{-2}$ (to the nearest integer).

$$\text{Given, } 2.303 \frac{RT}{F} = 0.06 \text{ V; } E_{\text{AgCl}|\text{AgCl}}^0 = 0.22 \text{ V}$$

Answer (142)

24. The mole fraction of glucose ($\text{C}_6\text{H}_{12}\text{O}_6$) in an aqueous binary solution is 0.1. The mass percentage of water in it, to the nearest integer, is _____

Answer (47)

25. The total number of monohalogenated organic products in the following (including stereoisomers) reaction is _____.



(Simplest optically active alkene)

Answer (8)



PART-C : MATHEMATICS

SECTION - I

Multiple Choice Questions: This section contains 20 multiple choice questions. Each question has 4 choices (1), (2), (3) and (4), out of which **ONLY ONE** is correct.

Choose the correct answer :

1. Let P be a point on the parabola, $y^2 = 12x$ and N be the foot of the perpendicular drawn from P on the axis of the parabola. A line is now drawn through the mid-point M of PN, parallel to its axis which meets the parabola at Q. If the

y-intercept of the line NQ is $\frac{4}{3}$, then :

- (1) $MQ = \frac{1}{4}$ (2) $PN = 3$
(3) $PN = 4$ (4) $MQ = \frac{1}{3}$

Answer (1)

2. If $\Delta = \begin{vmatrix} x-2 & 2x-3 & 3x-4 \\ 2x-3 & 3x-4 & 4x-5 \\ 3x-5 & 5x-8 & 10x-17 \end{vmatrix} =$

$Ax^3 + Bx^2 + Cx + D$, then $B + C$ is equal to :

- (1) 9
(2) -1
(3) 1
(4) -3

Answer (4)

3. The area (in sq. units) of the region

$\left\{ (x, y) : 0 \leq y \leq x^2 + 1, 0 \leq y \leq x + 1, \frac{1}{2} \leq x \leq 2 \right\}$ is :

- (1) $\frac{79}{16}$ (2) $\frac{23}{6}$
(3) $\frac{79}{24}$ (4) $\frac{23}{16}$

Answer (3)

4. If α and β are the roots of the equation $x^2 + px + 2 = 0$ and $\frac{1}{\alpha}$ and $\frac{1}{\beta}$ are the roots of the equation $2x^2 + 2qx + 1 = 0$, then $\left(\alpha - \frac{1}{\alpha}\right)\left(\beta - \frac{1}{\beta}\right)\left(\alpha + \frac{1}{\beta}\right)\left(\beta + \frac{1}{\alpha}\right)$ is equal to :

- (1) $\frac{9}{4}(9 - q^2)$ (2) $\frac{9}{4}(9 + p^2)$
(3) $\frac{9}{4}(9 + q^2)$ (4) $\frac{9}{4}(9 - p^2)$

Answer (4)

5. The value of $(2 \cdot 1P_0 - 3 \cdot 2P_1 + 4 \cdot 3P_2 - \dots$ up to 51th term) + $(1! - 2! + 3! - \dots$ up to 51th term) is equal to :

- (1) 1 (2) $1 + (52)!$
(3) $1 - 51(51)!$ (4) $1 + (51)!$

Answer (2)

6. $\int_{-\pi}^{\pi} |\pi - |x|| dx$ is equal to :

- (1) π^2 (2) $2\pi^2$
(3) $\sqrt{2}\pi^2$ (4) $\frac{\pi^2}{2}$

Answer (1)

7. Let $[t]$ denote the greatest integer $\leq t$. If for some $\lambda \in \mathbb{R} - \{0, 1\}$, $\lim_{x \rightarrow 0} \frac{1 - x + |x|}{\lambda - x + [x]} = L$, then L is equal to :

- (1) 2 (2) $\frac{1}{2}$
(3) 0 (4) 1

Answer (1)

8. $2\pi - \left(\sin^{-1} \frac{4}{5} + \sin^{-1} \frac{5}{13} + \sin^{-1} \frac{16}{65} \right)$ is equal to :

- (1) $\frac{\pi}{2}$ (2) $\frac{7\pi}{4}$
(3) $\frac{3\pi}{2}$ (4) $\frac{5\pi}{4}$

Answer (3)

9. The function, $f(x) = (3x - 7)x^{2/3}$, $x \in \mathbb{R}$, is increasing for all x lying in :

(1) $(-\infty, 0) \cup \left(\frac{14}{15}, \infty\right)$

(2) $(-\infty, 0) \cup \left(\frac{3}{7}, \infty\right)$

(3) $\left(-\infty, -\frac{14}{15}\right) \cup (0, \infty)$

(4) $\left(-\infty, \frac{14}{15}\right)$

Answer (1)

10. The foot of the perpendicular drawn from the point $(4, 2, 3)$ to the line joining the points $(1, -2, 3)$ and $(1, 1, 0)$ lies on the plane :

(1) $x - 2y + z = 1$

(2) $x + 2y - z = 1$

(3) $x - y - 2z = 1$

(4) $2x + y - z = 1$

Answer (4)

11. A die is thrown two times and the sum of the scores appearing on the die is observed to be a multiple of 4. Then the conditional probability that the score 4 has appeared atleast once is :

(1) $\frac{1}{3}$

(2) $\frac{1}{4}$

(3) $\frac{1}{8}$

(4) $\frac{1}{9}$

Answer (4)

12. If the number of integral terms in the

expansion of $\left(3^{\frac{1}{2}} + 5^{\frac{1}{8}}\right)^n$ is exactly 33, then the

least value of n is :

(1) 264

(2) 128

(3) 256

(4) 248

Answer (3)

13. A hyperbola having the transverse axis of length $\sqrt{2}$ has the same foci as that of the ellipse of $3x^2 + 4y^2 = 12$, then this hyperbola does not pass through which of the following points?

(1) $\left(-\sqrt{\frac{3}{2}}, 1\right)$

(2) $\left(\sqrt{\frac{3}{2}}, \frac{1}{\sqrt{2}}\right)$

(3) $\left(\frac{1}{\sqrt{2}}, 0\right)$

(4) $\left(1, -\frac{1}{\sqrt{2}}\right)$

Answer (2)

14. If the first term of an A.P. is 3 and the sum of its first 25 terms is equal to the sum of its next 15 terms, then the common difference of this A.P. is :

(1) $\frac{1}{6}$

(2) $\frac{1}{4}$

(3) $\frac{1}{7}$

(4) $\frac{1}{5}$

Answer (1)

15. Consider the two sets :

$A = \{m \in \mathbb{R} : \text{both the roots of } x^2 - (m + 1)x + m + 4 = 0 \text{ are real}\}$ and $B = [-3, 5)$.

Which of the following is **not** true?

(1) $A \cap B = \{-3\}$

(2) $B - A = (-3, 5)$

(3) $A \cup B = \mathbb{R}$

(4) $A - B = (-\infty, -3) \cup (5, \infty)$

Answer (4)

16. The solution curve of the differential equation,

$(1 + e^{-x})(1 + y^2) \frac{dy}{dx} = y^2$, which passes through

the point $(0, 1)$, is :

(1) $y^2 + 1 = y \left(\log_e \left(\frac{1 + e^{-x}}{2} \right) + 2 \right)$

(2) $y^2 + 1 = y \left(\log_e \left(\frac{1 + e^x}{2} \right) + 2 \right)$

(3) $y^2 = 1 + y \log_e \left(\frac{1 + e^{-x}}{2} \right)$

(4) $y^2 = 1 + y \log_e \left(\frac{1 + e^x}{2} \right)$

Answer (4)

17. The lines

$$\vec{r} = (\hat{i} - \hat{j}) + l(2\hat{i} + \hat{k}) \text{ and}$$

$$\vec{r} = (2\hat{i} - \hat{j}) + m(\hat{i} + \hat{j} - \hat{k})$$

(1) do not intersect for any values of l and m

(2) intersect for all values of l and m

(3) intersect when $l = 2$ and $m = \frac{1}{2}$

(4) intersect when $l = 1$ and $m = 2$

Answer (1)

18. If $y^2 + \log_e(\cos^2 x) = y$, $x \in \left(-\frac{\pi}{2}, \frac{\pi}{2}\right)$, then :

(1) $|y'(0)| + |y''(0)| = 3$

(2) $|y'(0)| + |y''(0)| = 1$

(3) $y''(0) = 0$

(4) $|y''(0)| = 2$

Answer (4)

19. The proposition $p \rightarrow \sim(p \wedge \sim q)$ is equivalent to:

(1) q

(2) $(\sim p) \wedge q$

(3) $(\sim p) \vee (\sim q)$

(4) $(\sim p) \vee q$

Answer (4)

20. For the frequency distribution :

Variate (x) : $x_1 \quad x_2 \quad x_3 \quad \dots \quad x_{15}$

Frequency (f) : $f_1 \quad f_2 \quad f_3 \quad \dots \quad f_{15}$

where $0 < x_1 < x_2 < x_3 < \dots < x_{15} = 10$ and

$\sum_{i=1}^{15} f_i > 0$, the standard deviation cannot be :

(1) 1

(2) 6

(3) 2

(4) 4

Answer (2)

SECTION - II

Numerical Value Type Questions: This section contains 5 questions. The answer to each question is a NUMERICAL VALUE. For each question, enter the correct numerical value (in decimal notation, truncated/rounded off to the second decimal place; e.g. 06.25, 07.00, -00.33, -00.30, 30.27, -27.30) using the mouse and the on-screen virtual numeric keypad in the place designated to enter the answer.

21. If $\left(\frac{1+i}{1-i}\right)^{m/2} = \left(\frac{1+i}{i-1}\right)^{n/3} = 1$, ($m, n \in \mathbb{N}$) then the greatest common divisor of the least values of m and n is _____.

Answer (4)

22. The diameter of the circle, whose centre lies on the line $x + y = 2$ in the first quadrant and which touches both the lines $x = 3$ and $y = 2$, is _____.

Answer (3)

23. If $\lim_{x \rightarrow 0} \left\{ \frac{1}{x^8} \left(1 - \cos \frac{x^2}{2} - \cos \frac{x^2}{4} + \cos \frac{x^2}{2} \cos \frac{x^2}{4} \right) \right\} = 2^{-k}$, then the value of k is _____.

Answer (8)

24. Let $A = \begin{bmatrix} x & 1 \\ 1 & 0 \end{bmatrix}$, $x \in \mathbb{R}$ and $A^4 = [a_{ij}]$. If $a_{11} = 109$, then a_{22} is equal to _____.

Answer (10)

25. The value of $(0.16)^{\log_{2.5} \left(\frac{1}{3} + \frac{1}{3^2} + \frac{1}{3^3} + \dots \text{ to } \infty \right)}$ is equal to _____.

Answer (4)

