



# PIONEER

Pioneer Probe——sharp tool of CNC machining

WWW.PIONEERGROUP.COM.CN



Harbin Pioneer M&E Technical  
Development Co., Ltd

Harbin pioneer M&E technical development Co., Ltd was established by Mr. Sun Baichun in 1995 .After several years of development, the company gradually determined it's main business ----- CNC machine tool probe development, production and sales. In 1999, the company officially changed its name to Harbin pioneer M&E technical development Co, Ltd.

In the past two decades, Pioneer focused on the field of CNC machine tool probe operation. We developed probe, tool setter and a variety of probe stylus this three series of products. As the first manufacturer in the field of CNC machine tool probe in China, Pioneer has always insisted on independent development, and work hard to track the world's advanced level. In recent years, we research and develop two new probe systems. They are radio probe system and optical probe system, and their main technical indicators have reached the international advanced level.

Pioneer has a dozen of product patents, and Pioneer is also one of the two drafting units of national industry standard "trigger sensor" (JB / T5215-2007). In the years of development, Pioneer also developed a variety of devices that used in testing the probes and tool setters performance and technical indicators, and designated a series of detection methods, has accumulated a wealth of manufacturing experience. All of these effort make pioneer formed a unique technology and product competitiveness, making Pioneer become a domestic and international well-known brands in CNC machine tools probe field.

In 2013, Marposs S.p.A, became one of the shareholders of Pioneer, and Pioneer became a Sino-foreign joint venture company.





### What's CNC machine tool probe products?

CNC machine tool probe products include: workpiece probe used to measure the workpiece parameters on the machine tool, and tool setter to measure the tool (tool probe). The most important characteristics of these products is that it makes full use of the CNC machine tool has a precise location records and program control motor function, through a combination of hardware and software of probe products, make the CNC machine tool 's working efficiency and machining accuracy greatly improved.

### Main application of CNC machine tool workpiece probe products:

- 1) Measure and find the base position of the workpiece or tooling quickly and accurately, set or modify the workpiece/machining coordinate automatically;
- 2) Optimize machining allowance control to ensure the quality and consistency of batch products;
- 3) Implement testing during the machining cycle, Control the influence of tool wear on machining accuracy;
- 4) Implement critical dimension precision testing after machining cycle, and improve the qualification rate;
- 5) Simplify or cancel special fixture and reduce the production cost;
- 6) Shorten the auxiliary time of the machine tool and improve the production efficiency;
- 7) Reduce the manual operation, reduce labor intensity and the influence of human operation factor to the product processing precision.

### Main application of tool setter( tool probe )products:

- 1) Measure、 correct tool length and diameter offset value quickly and accurately;
- 2) Reduce the manual operation, reduce labor intensity and the influence of human operation factor to the tool setting precision;
- 3) The influence of temperature change on machining precision is controlled by measuring tool parameters;
- 4) Monitor tool wear and tear, reduce rejection rate;
- 5) Shorten the auxiliary time of the machine tool and improve the production efficiency.

### Pioneer probe products Classification:

- 1) classification by function: workpiece probe and tool probe (also called tool setter);
- 2) classification by work method: automatic working mode and manual working mode;
- 3) classification by signal transmission: cable、 electrical inductance、 optical and radio.

## How to select the correct and applicable products quickly and accurately?

If you can follow the guidelines to refer to this brochure, it will save you time;

If you have plenty of time, you can start to learn about the various products from the following product catalog.

### Quickly find products that are useful to you :

First, Identify the problems you want to solve (refer to the following questions: A, B, C);

A. Workpiece problem 《product selection table -1》 : set workpiece processing benchmark, measure workpiece size, control machining precision, etc;

B. Tool problem 《product selection table -2》 : product selection table -2" : tool length or diameter parameter setting, tool wear or damage control, etc;

C. Stylus selection: please refer to 《stylus selection brochure》 .

Second, According to your equipment type and the way you want to solve the problem (auto or manual), you can find out which products you should to look in the following 《product selection table -1/2》 ;

Third, According to the page numbers marked in the corresponding products in the 《product selection table -1/2》 , You can find detailed information of the products.

Product selection table -1

NO.	Name	Model	Working method	Type of machine	Page No.(Hardware)	Page No.( Software)
1	Optical probe system	OPS-30	Automation	Medium/small machining center, CNC boring and milling machine	P01	SP-W10/P17
2	Radio probe system	RPS-20 Series	Automation	Large/medium machining center, CNC boring, milling machine, CNC mill/turn center	P03	SP-W10/P17
3	Radio probe system	RPS-L11	Automation	CNC lathe, turning center	P05	SP-W50/P17
4	Cable probe	TP300 Series	Automation	CNC grinding machine, CNC lathe, special measuring equipment, etc	P07	
5	Cable probe	TP400	Automation	CNC grinding machine, small CNC boring, milling machine, etc	P08	
6	Trigger Probe	TP60	Manual	Machining center, CNC boring and milling machine	P09	No software
7	Electric Probe	EP60/EP40	Manual	Machining center, CNC boring and milling machine	P10	No software

Product selection table -2

N O.	Name	Model	Working method	Type of machine	Page No.(Hardware)	Page No.( Software)
1	Cable Tool Setter	TTC100	Automation	Machining center, CNC boring and milling machine/ Length Measuring	P12	SP-T10/P17
2	Cable Tool Setter	TTC200	Automation	Machining center, CNC boring and milling machine/Length and Diameter Measuring	P13	SP-T10/P17
3	Cable Tool Setter	TTC400A	Automation	CNC lathe, turning center/Diameter Measuring	P14	SP-T10/P17
4	Portable tool Setter	TTC10	Manual	Machining center, CNC boring and milling machine	P15	No Software

# Contents

No.	Products Name	Products Model	Page
1	Optical probe system	OPS-30	P01
2	Radio probe system	RPS-20 Series	P03
3	Radio probe system	RPS-L11Series	P05
4	Cable probe	TP300Series	P07
5	Cable probe	TP400	P08
6	Trigger Probe	TP60	P09
7	Electric Probe	EP60/EP40	P10
Tool Setter		Products Model	
8	Cable Tool Setter	TTC100	P12
9	Cable Tool Setter	TTC200	P13
10	Cable Tool Setter	TTC400A	P14
11	Portable tool Setter	TTC10	P15
Stylus and others		Products Model	
12	Stylus		P16
13	Software for Probe	SP-W10/W50	P17
14	Software for Tool Setter	SP-T10	P17

## Composition of Probe System

OPS-30 series optical probe system include two pieces of hardware and one software package; The software package model is SP-W10, the two pieces of the hardware are:

- 1) OP510 optical probe (including optional shank and stylus );
- 2) OSI-20 optical receiver(the standard cable length 8m/the optional lengthened cable).

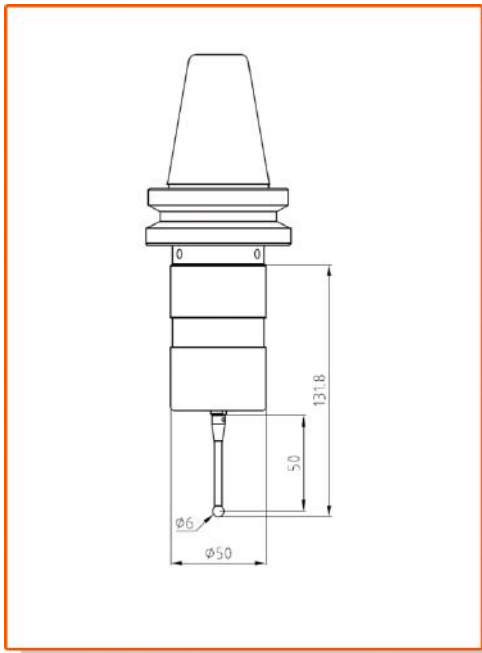
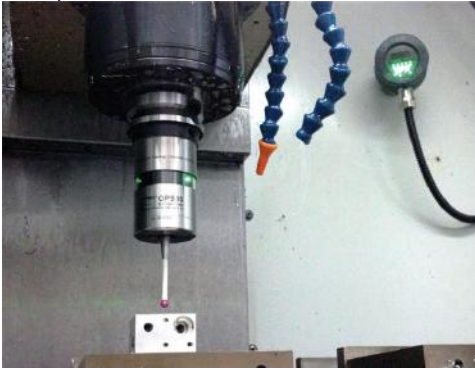

## Technical Parameters

- 1) The technical parameters of OP510 optical probe :
  - ◆ Stylus sensing direction:  $\pm X, \pm Y, +Z$ ;
  - ◆ Stylus sensing over-travel :  $X-Y \pm 15^\circ, Z +5 \text{ mm}$ ;
  - ◆ The adjusting range of trigger force in Z direction: 500-1000 g;
  - ◆ Trigger force in X-Y surface: 50g -100g;
  - ◆ Unidirectional repeatability ( $2\sigma$ ) :  $\leq 2 \mu\text{m}$ ;
  - ◆ Optical signal receiving/sending distance :  $\geq 5$ ;
  - ◆ Working days of new batteries ( 5% utilization rate in a single shift): 140 days;
  - ◆ Seal grade: IP68.
- 2) OSI-20 optical receiver technical parameters:
  - ◆ Optical signal receiving/sending distance:  $\geq 5 \text{ m}$ ;
  - ◆ For the probe switch on/off with M code, The optical signal transmission range can be adjusted to four grade: 5-6 m, 3.75-4m, 2.5-3m, 1.25-1.5m;
  - ◆ Input voltage is  $24 \pm 10\% \text{ V DC}$  and output load current is 50 mA.

## Technical Characteristics

- ◆ Probe switch on/off method: Range on/off、M code on/off;
- ◆ Infrared coded signals are used to transmit information between the probe and the receiver;
- ◆ The transmitting distance of the probe signal can be adjusted by trigger probe with special program to set the receiver;
- ◆ Output four kinds of SSR signals to machine control system when probe is in the states of trigger、error、probe batteries low and output pulse;
- ◆ The OSI-20 receiver can change its logical state of the output signal by setting;
- ◆ Double infrared signal receiving and transmitting devices are used to increase the reliability of the equipment;
- ◆ The LED lights in the receiver show the working status of the probe system.

## Application

- ◆ Setting work-piece coordinate system and machining zero points automatically before processing;
- ◆ Detect and control the key dimensions, position coordinates and their precision automatically between two processes;
- ◆ Detect precision of the key dimensions, shapes, position after processing.

## Applicable equipment

- ◆ Various specifications of machine center, CNC boring-milling machine, drilling machine center and so on.
- ◆ Various specifications of CNC lathes, turning machine center, CNC turning-milling machine center.

## Basic configuration

### 1) OP510 Probe

- ◆ Standard stylus model: M4-P50-RB6-S36;
- ◆ Battery specification: 14250, 3.6V, 1000mAh; 2 ps.;
- ◆ Usually, the probe shank is 7:24 taper shank with the BT or ISO standards, the common models are 30#,40#,50# and etc.; the shank with the HSK or other standards can also be used.

### 2) OSI-20 Receiver

- ◆ The cable length usually is 8 meters with 13 cores' shielded cable;
- ◆ Fixed bracket with universal adjustment function is equipped.

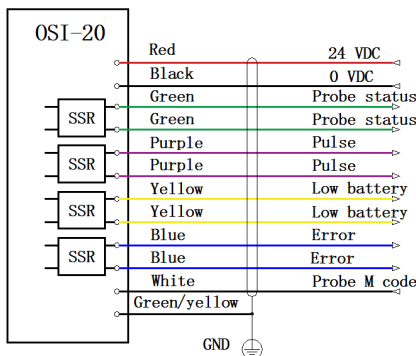
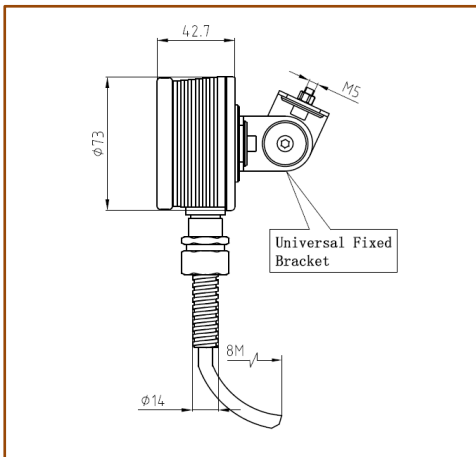

## Notes:

- ◆ As for the software package, please consult the our sales staff about whether the CNC system of the machine tool can be equipped with probe; Some CNC systems needs additional settings to use probe;
- ◆ As for the probe's taper shank, verify the standards and specifications of the spindle taper hole for the machine tool before ordering the probe; The taper shank with unusual standard or specification will lead to the probe price increase and the delivery time extend, The tapered shank we provided for the probe does not include the pull stud;
- ◆ As for function of the M code on/off, when purchasing the OPS-30 probe system, you should figure out whether there are two spare M codes in the CNC control system cabinet for the probe to use;
- ◆ As for special stylus, checking whether the standard stylus equipped with the OP510 series probe can meet the requirements and thinking whether it is necessary to order a special stylus;
- ◆ As for the cable length, verify if the 8-meter cable equipped with the OSI-20 receiver is enough for installing it in the machine tool. If it is not, the additional instruction is required when ordering the product;
- ◆ As for the installation of the OSI-20 receiver, if user does not want to drill a hole on the machine tool cover when installing the receiver, an additional magnetic sucker can be ordered to install the receiver without hole. But buying magnetic sucker may affect the product delivery time.

## Composition of Probe System

RPS-20 radio probe system include two pieces of hardware and one software package; The software package model is SP-W10, the two pieces of the hardware are:

- 1) RP610 radio probe (including optional shank and stylus );
- 2) RSI-20 radio receiver(the standard cable length 8m/the optional lengthened cable).

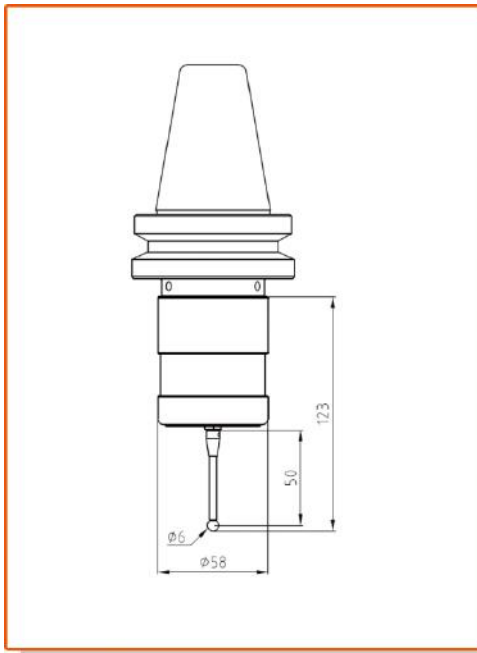
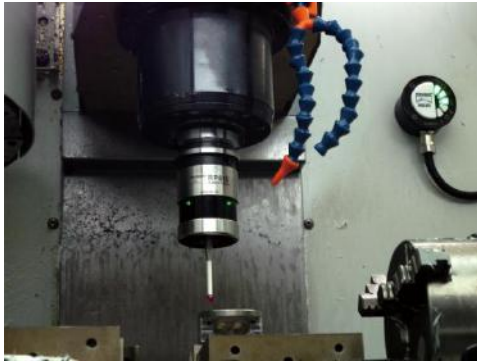

## Application

- ◆ Setting work-piece coordinate system and machining zero points automatically before processing;
- ◆ Detect and control the key dimensions, position coordinates and their precision automatically between two processes;
- ◆ Detect precision of the key dimensions, shapes, position after processing.

## Technical Parameters

- 1) The technical parameters of RP610 radio probe :
  - ◆ Stylus sensing direction:  $\pm X, \pm Y, +Z$ ;
  - ◆ Stylus sensing over-travel :  $X-Y \pm 15^\circ, Z +5 \text{ mm}$ ;
  - ◆ The adjusting range of trigger force in Z direction: 500-1000 g;
  - ◆ Trigger force in X-Y surface: 50g-100g;
  - ◆ Unidirectional repeatability ( $2\sigma$ ) :  $\leq 2 \mu\text{m}$ ;
  - ◆ Radio signal receiving/sending distance :  $\geq 14 \text{ m}$ ;
  - ◆ Working days of new batteries ( 5% utilization rate in a single shift): 280 days;
  - ◆ Seal grade: IP68.
- 2) RSI-20 radio receiver technical parameters:
  - ◆ Radio signal receiving/sending distance:  $\geq 14 \text{ m}$ ;
  - ◆ Input voltage is  $24 \pm 10\% \text{ V DC}$  and output load current is 50 mA.

## Technical Characteristics

- ◆ Probe switch on/off method: Range on/off、M code on/off;
- ◆ Radio code signals are used to transmit information between the probe and the receiver. The time to transmit and to decode a group of signals is less than 1ms;
- ◆ The transmission frequency of the radio signal is within 2.4 G-2.483 G, the number of transmission channel is 84;
- ◆ Output four kinds of SSR signals to machine control system when probe is in the states of trigger、error、probe batteries low and output pulse;
- ◆ The RSI-20 receiver can change its logical state of the output signal by setting;
- ◆ The LED lights in the receiver show the working status of the probe system.

## Applicable equipment

- ◆ Various specifications of machine center, large-scale gantry machine, five-axis CNC machine tools and so on.
- ◆ Various specifications of CNC lathes, turning machine center, CNC turning-milling machine center.



## Basic configuration

### 1) RP610 Probe

- ◆ Standard stylus model: M4-P50-RB6-S36;
- ◆ Battery specification: 14250, 3.6V, 1000mAh; 2 ps.;
- ◆ Usually, the probe shank is 7:24 taper shank with the BT or ISO standards, the common models are 30#,40#,50# and etc.; the shank with the HSK or other standards can also be used.

### 2) RSI-20 Receiver

- ◆ The cable length usually is 8 meters with 13 cores' shielded cable;
- ◆ Fixed bracket with universal adjustment function is equipped.

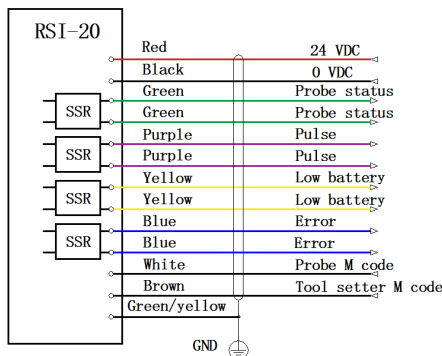
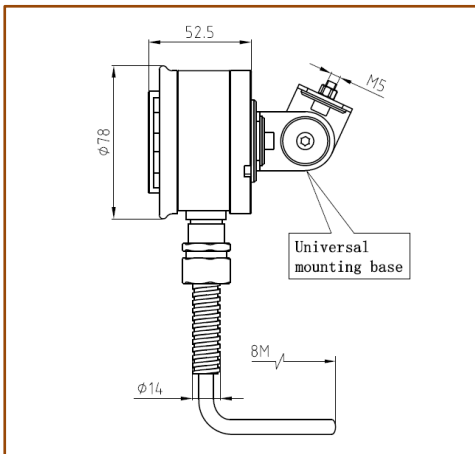

## Notes:

- ◆ As for the software package, please consult the our sales staff about whether the CNC system of the machine tool can be equipped with probe; Some CNC systems needs additional settings to use probe;
- ◆ As for the probe's taper shank, verify the standards and specifications of the spindle taper hole for the machine tool before ordering the probe; The taper shank with unusual standard or specification will lead to the probe price increase and the delivery time extend, The tapered shank we provided for the probe does not include the pull stud;
- ◆ As for function of the M code on/off, when purchasing the RPS-20 probe system, you should figure out whether there are two spare M codes in the CNC control system cabinet for the probe to use;
- ◆ As for special stylus, checking whether the standard stylus equipped with the RP610 probe can meet the requirements and thinking whether it is necessary to order a special stylus;
- ◆ As for the cable length, verify if the 8-meter cable equipped with the RSI-20 receiver is enough for installing it in the machine tool. If it is not, the additional instruction is required when ordering the product;
- ◆ As for the installation of the RSI-20 receiver, if user does not want to drill a hole on the machine tool cover when installing the receiver, an additional magnetic sucker can be ordered to install the receiver without hole. But buying magnetic sucker may affect the product delivery time.

## Composition of Probe System

RPS-L11 radio probe system include three pieces of hardware and one software package; The software package model is SP-W10, the two pieces of the hardware are:

- 1) TP200 trigger probe unit(including optional stylus );
- 2) RPD/RPDM radio signal transmitter (including customizable mounting plate);
- 3) RSI-20 radio receiver(the standard cable length 8m/the optional lengthened cable).

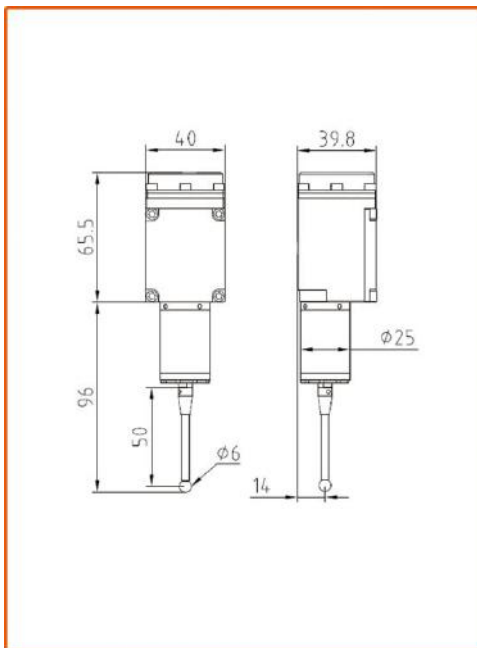

## Application

- ◆ Setting work-piece coordinate system and machining zero points automatically before processing;
- ◆ Detect and control the key dimensions, position coordinates and their precision automatically between two processes;
- ◆ Detect precision of the key dimensions, shapes, position after processing.

## Technical Parameters

- 1) The technical parameters of TP200 trigger probe :
  - ◆ Stylus sensing direction:  $\pm X$ ,  $\pm Y$ ,  $+Z$ ;
  - ◆ Stylus sensing over-travel :  $X-Y \pm 15^\circ$  ,  $Z +5$  mm;
  - ◆ The trigger force in Z direction: 1000 g;
  - ◆ Trigger force in X-Y surface ( standard stylus ) : 65-130g;
  - ◆ Unidirectional repeatability ( $2\sigma$ ) :  $\leq 2 \mu\text{m}$ ;
  - ◆ Seal grade: IP68.
- 2) The technical parameters of RPD/RPDM radio signal transmitter:
  - ◆ Radio signal receiving/sending distance :  $\geq 14$  m;
  - ◆ Working days of new batteries (5% utilization rate in a single shift): 280 days;
  - ◆ Seal grade: IP68.
- 3) RSI-20 radio receiver technical parameters:
  - ◆ Radio signal receiving/sending distance:  $\geq 14$  m;
  - ◆ Input voltage is  $24 \pm 10\%$  V DC and output load current is 50 mA.
  - ◆ Seal grade: IP68.

## Technical Characteristics

- ◆ The stylus connector of TP200 probe is protected by a metal cover and a rubber seal cover;
- ◆ Switch on/off method of RPD/RPDM radio signal emitter: M code on/off;
- ◆ Radio code signals are used to transmit information between RPD/RPDM radio signal emitter and the receiver. The time to transmit and to decode a group of signals is less than 1ms;
- ◆ The transmission frequency of the radio signal is within 2.4 G-2.483 G, the number of transmission channel is 84;
- ◆ Output four kinds of SSR signals to machine control system when probe is in the states of trigger、 error、 probe batteries low and output pulse;
- ◆ The RSI-20 receiver can change its logical state of the output signal by setting;
- ◆ The indicating lights in RSI-20 and RPDM show the working status of the probe system.

## Applicable equipment

- ◆ Various specifications of CNC lathes, turning machine center, CNC turning-milling machine center.

## Basic configuration

### 1) TP200 Probe

◆ Standard stylus model: M4-P50-RB6-S36;

### 2) RPD/RPDM signal transmitter

◆ Battery specification: 14250, 3.6V, 1000mAh, 2 ps.;

◆ The mounting plate is usually designed and made according to the specifications of customers' lathe carriages.

### 2) RSI-20 Receiver

◆ The cable length usually is 8 meters with 13 cores' shielded cable;

◆ Fixed bracket with universal adjustment function is equipped.

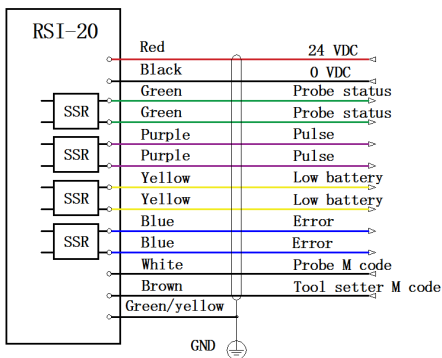
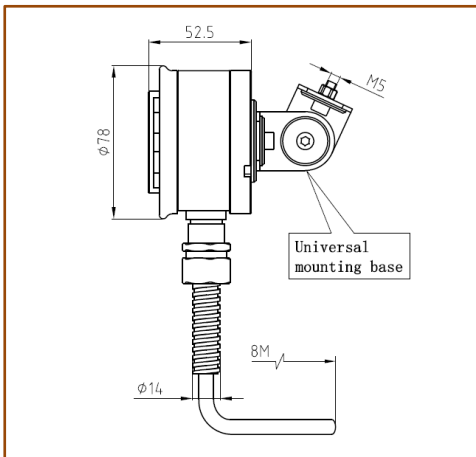

## Notes:

◆ As for the software package, please consult the our sales staff about whether the CNC system of the machine tool can be equipped with probe; Some CNC systems needs additional settings to use probe;

◆ As for the mounting plate, users shall first provide us the structure diagram and specific size of the CNC lathe carriage, then we will decide whether the mounting plate of RPD/RPDM needs to be designed and manufactured all alone;

◆ As for function of the M code on/off, when purchasing the RPS-L11 probe system, you should figure out whether there are two spare M codes in the CNC control system cabinet for the probe to use;

◆ As for special stylus, checking whether the standard stylus equipped with the TP200 probe can meet the requirements and thinking whether it is necessary to order a special stylus;

◆ As for the cable length, verify if the 8-meter cable equipped with the RSI-20 receiver is enough for installing it in the machine tool. If it is not, the additional instruction is required when ordering the product;

◆ As for the installation of the RSI-20 receiver, if user does not want to drill a hole on the machine tool cover when installing the receiver, an additional magnetic sucker can be ordered to install the receiver without hole. But buying magnetic sucker may affect the product delivery time.

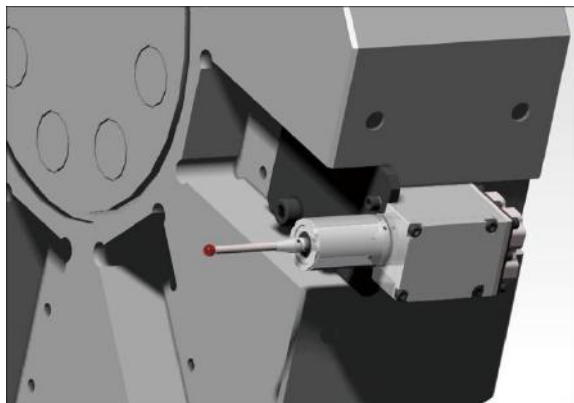

## Composition of Probe

TP300 series of cable probe consist of three pieces:

- 1) TP300 trigger probe unit;
- 2) HPI-A16 (axial outlet) or HPI-R16 (radial outlet) probe shank containing the probe's interface and cable;
- 3) Stylus(standard model: M4-P50-RB6-S36).



## Technical Parameters

1) The technical parameters of TP300 trigger probe :

- ◆ Stylus sensing direction:  $\pm X, \pm Y, +Z$ ;
- ◆ Stylus sensing over-travel :  $X-Y \pm 15^\circ, Z +5 \text{ mm}$ ;
- ◆ The trigger force in Z direction: 1000 g;
- ◆ Trigger force in X-Y surface ( standard stylus ) : 65-130g;
- ◆ Unidirectional repeatability ( $2\sigma$ ) :  $\leq 2 \mu\text{m}$ ;
- ◆ Seal grade: IP68.

2) The technical parameters of probe's interface:

- ◆ Input voltage is  $24 \pm 10\% \text{ V DC}$  and output load current is 50 mA.
- ◆ Seal grade: IP68.

## Technical Characteristics

- ◆ The signal interface of probe is integrated inside the probe shank, and the trigger signal is transmitted by cable;
- ◆ By changing the power supply's polarity at the probe interface, the logic state of the output signal can be reversed;
- ◆ The stylus connector of the probe is protected by double layers of rubber seal.

## Application

- ◆ Setting work-piece coordinate system and machining zero points automatically before processing;
- ◆ Detect and control the key dimensions, position coordinates and their precision automatically between two processes;
- ◆ Detect precision of the key dimensions, shapes, position after processing.
- ◆ Applicable equipments: various specifications of CNC grinding machines, CNC lathes and specially measuring devices.

## Notes for purchase

- ◆ As for special stylus, check whether the standard stylus equipped with the TP300 probe can meet the requirements and whether it is necessary to order special stylus;
- ◆ About sealing protection of the connectors for stylus and probe: for TP300 probe applied in CNC lathe, it is recommended that the customer give protecting instruction to use metal cover + rubber sealing cover when ordering the probe.

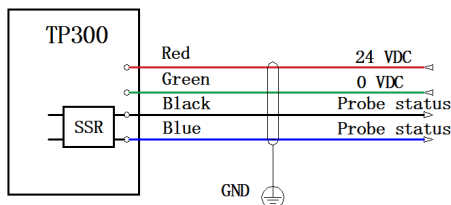
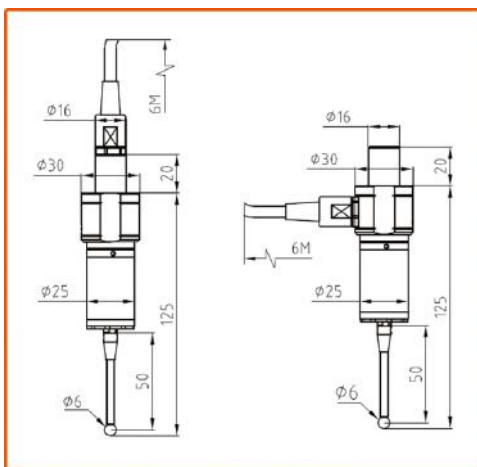

## Basic configuration

- ◆ The standard: M4-P50-RB6-S36;
- ◆ The model of crash protecting pole: S-11-016;
- ◆ The cable: 4 cores' shielded, oil - proof moving cable, length: 6m.

## Composition of Probe

- TP400 cable probe consist of three pieces:
- 1) TP400 trigger probe unit(with integrating interface);
  - 2) Two four-core, oil proof shielded cable, one of them is a spiral cable with aviation plugs at both ends. The total length of the two cables is 8 meters;
  - 3) Stylus(standard model: M4-P50-RB6-S36).

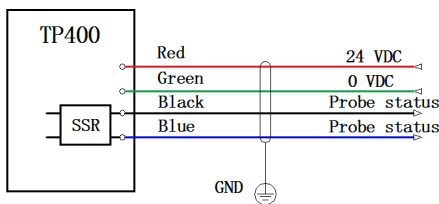
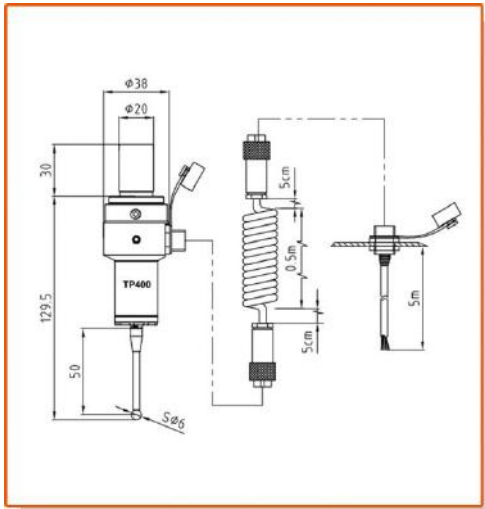

## Notes for purchase

- ◆ As for special stylus, check whether the standard stylus equipped with the TP400 probe can meet the requirements and whether it is necessary to order special stylus;
- ◆ About sealing protection of the connectors for stylus and probe: for TP300 probe applied in CNC lathe, it is recommended that the customer give protecting instruction to use metal cover + rubber sealing cover when ordering the probe.

## Technical Parameters for probe and interface

- ◆ Stylus sensing direction:  $\pm X, \pm Y, +Z$ ;
- ◆ Stylus sensing over-travel:  $X-Y \pm 15^\circ, Z +5 \text{ mm}$ ;
- ◆ The trigger force in Z direction: 1000 g;
- ◆ Trigger force in X-Y surface ( standard stylus ) : 65-130g;
- ◆ Unidirectional repeatability ( $2\sigma$ ) :  $\leq 2 \mu\text{m}$ ;
- ◆ Input voltage is  $24 \pm 10\% \text{ V DC}$  and output load current is 50 mA.
- ◆ Seal grade: IP68.

## Technical Characteristics

- ◆ The signal interface of probe is integrated inside the probe, and the trigger signal is transmitted by cable;
- ◆ By changing the power supply's polarity at the probe interface, the logic state of the output signal can be reversed;
- ◆ The stylus connector of the probe is protected by double layers of rubber seal.
- ◆ The probe uses two pieces of cable to transmit signals, one of spiral cable has aviation plugs at both ends , which can be quickly installed and discounted, providing convenience for the application of the probe in different equipments.

## Basic configuration

- ◆ The standard: M4-P50-RB6-S36;
- ◆ The cable: 4 cores' shielded, oil - proof sporting cable, length:6m.

## Application

- ◆ Setting work-piece coordinate system and machining zero points automatically before processing;
- ◆ Detect and control the key dimensions, position coordinates and their precision automatically between two processes;
- ◆ Detect precision of the key dimensions, shapes, position after processing.
- ◆ Applicable equipments: various specifications of CNC grinding machines, CNC lathes and specially measuring devices.

# STP-41 Probe - -simplified probe for CNC machines

## Function:

- Workpiece set-up and inspection
- Datum position set-up

## Features and benefits

- Detachable steel stylus
- Sensing directions:  $\pm X$ ,  $\pm Y$ ,  $+Z$
- Length of standard stylus: 32mm  
The diameter of stylus ball is  $4.0 \pm 0.001$  mm.
- Stylus overtravel :  
 $XY \pm 15^\circ$  ,  $Z+5$ mm
- The standard length of the communication cable is 2 m.

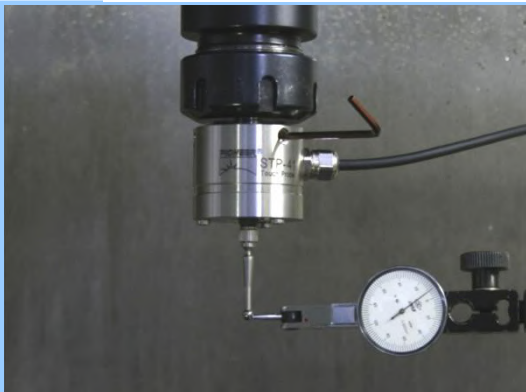
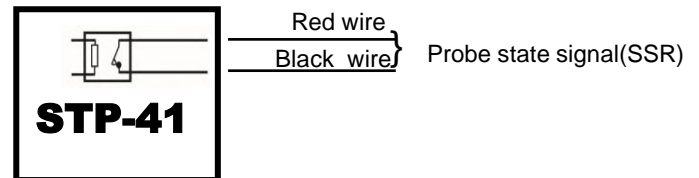
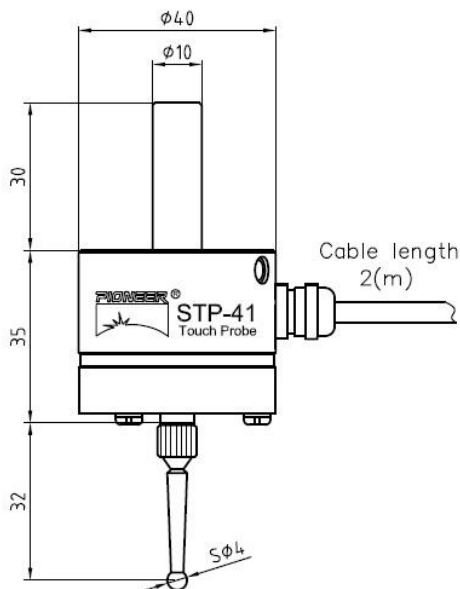

## Accuracy

- Unidirectional repeatability: 0.01mm
- Ball diameter:  $4.0 \pm 0.001$  (mm)
- Probe signal output: Normally closed
- Alignment of stylus with the axis of probe shank is adjustable as shown in illustration



## Composition of Probe

TP60 trigger probe consists of three pieces:

- 1) The main part of TP60 trigger probe (including battery cabin) ;
- 2) The 7:24 taper shank with standard of BT or ISO(the specification is optional) ;
- 3) Stylus(standard model: M4-P50-RB6-S36).

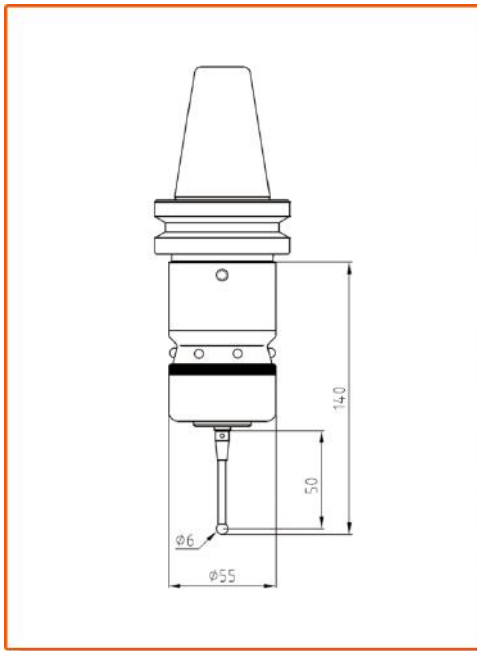

## Notes for purchase

- ◆ As for special stylus, check whether the standard stylus equipped with the TP60 probe can meet the requirements and whether it is necessary to order special stylus;
- ◆ As for the probe taper shank, verify the taper hole's standards and specifications of the machine tool spindle before ordering the probe; The uncommonly used standard and specifications of the taper shank will lead to the increase of probe price and the delay of delivery time, The taper shank provided by us for the probe isn't equipped with the pull stud.

## Technical Parameters

- ◆ Stylus sensing direction:  $\pm X, \pm Y, +Z$ ;
- ◆ Stylus sensing over-travel :  $X-Y \pm 15^\circ, Z +5 \text{ mm}$ ;
- ◆ The trigger force in Z direction: 1000 g;
- ◆ Trigger force in X-Y surface ( standard stylus ) : 65 -130g;
- ◆ Unidirectional repeatability ( $2\sigma$ ) :  $\leq 2 \mu\text{m}$ ;
- ◆ Seal grade: IP68.

## Technical Characteristics

- ◆ Coaxial adjustment function of probe and shank:  
By adjusting the connecting link between the main body of the probe and the taper shank, coaxiality about the center of the measuring ball on the stylus and the center line of the taper shank can be adjusted (the factory precision:  $\leq 5 \mu\text{m}$ );
- ◆ Six LED indicator lights are used to show the trigger state of the probe.

## Basic configuration

- ◆ The standard: M4-P50-RB6-S36;
- ◆ Usually, the probe shank is 7:24 taper shank with the BT or ISO standards (the specification is optional) ;
- ◆ A battery, model: CR2, 3.0 V, 800 mAh.

## Applicable equipment and working condition

- ◆ Suitable for various specifications of machine centers, CNC boring and milling machines, and drilling-tapping machine centers, etc;
- ◆ Suitable for checking work pieces of all kinds of solid materials.

## Application

- ◆ Setting work-piece coordinate system and machining zero points manually before processing;
- ◆ Detect and control the key dimensions, position coordinates and their precision manually between two processes;
- ◆ Detect precision of the key dimensions, shapes, position after processing.

## Composition of Probe

EP60 electric probe consists of three pieces:

- 1) The main part of EP60 electric probe (including battery cabin) ;
- 2) The 7:24 taper shank with standard of BT or ISO(the specification is optional) ;
- 3) Stylus(standard model: M4-S60-SB6-S58.5).

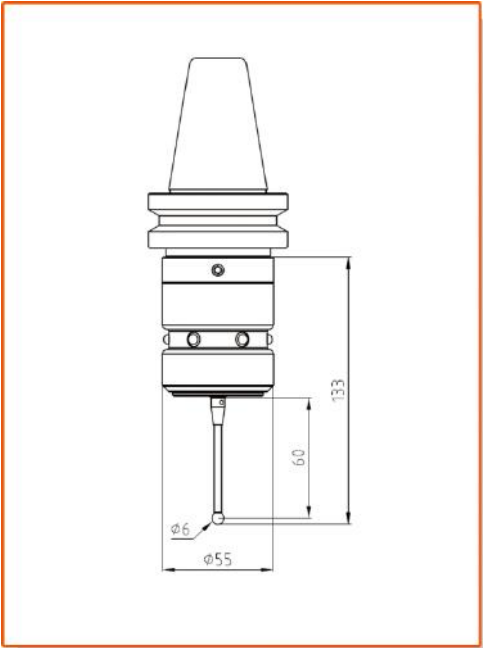

## Notes for purchase

- ◆ As for special stylus, check whether the standard stylus equipped with the EP60 probe can meet the requirements and whether it is necessary to order special stylus;
- ◆ As for the probe taper shank, verify the taper hole's standards and specifications of the machine tool spindle before ordering the probe; The uncommonly used standard and specifications of the taper shank will lead to the increase of probe price and the delay of delivery time, The taper shank provided by us for the probe isn't equipped with the pull stud;
- ◆ Verify whether the spindle of the CNC machine tool uses ceramic bearings. If ceramic bearings are used, please choose TP60 trigger probe.



## Technical Parameters

- ◆ Stylus sensing direction:  $\pm X, \pm Y, +Z$ ;
- ◆ Stylus sensing over-travel:  $X-Y \pm 15^\circ, Z +5 \text{ mm}$ ;
- ◆ The trigger force in Z direction: 1000 g;
- ◆ Trigger force in X-Y surface ( standard stylus ) : 65-130g;
- ◆ Unidirectional repeatability ( $2\sigma$ ) :  $\leq 2 \mu\text{m}$ ;
- ◆ Seal grade: IP68.

## Technical Characteristics

- ◆ Coaxial adjustment function of probe and shank:  
By adjusting the connecting link between the main body of the probe and the taper shank, coaxiality about the center of the measuring ball on the stylus and the center line of the taper shank can be adjusted (the factory precision:  $\leq 5 \mu\text{m}$ );
- ◆ Six LED indicator lights are used to show the trigger state of the probe.

## Basic configuration

- ◆ The standard: M4-S60-SB6-S58.5;
- ◆ Usually, the probe shank is 7:24 taper shank with the BT or ISO standards (the specification is optional) ;
- ◆ A battery, model: CR2, 3.0V, 800 mAh.

## Applicable equipment and working condition

- ◆ Suitable for various specifications of machine centers, CNC boring and milling machines, and drilling-tapping machine centers, etc;
- ◆ Suitable for checking work pieces of all kinds of solid materials with electrical conductivity.

## Application

- ◆ Setting work-piece coordinate system and machining zero points manually before processing;
- ◆ Detect and control the key dimensions, position coordinates and their precision manually between two processes;
- ◆ Detect precision of the key dimensions, shapes, position after processing.



## Composition of Probe

- 1) EP40 electric conducting probe has a cylindrical shank of 20mm diameter (the specification is optional );
- 2) Stylus(standard model: M4-S50-CB5-S30).

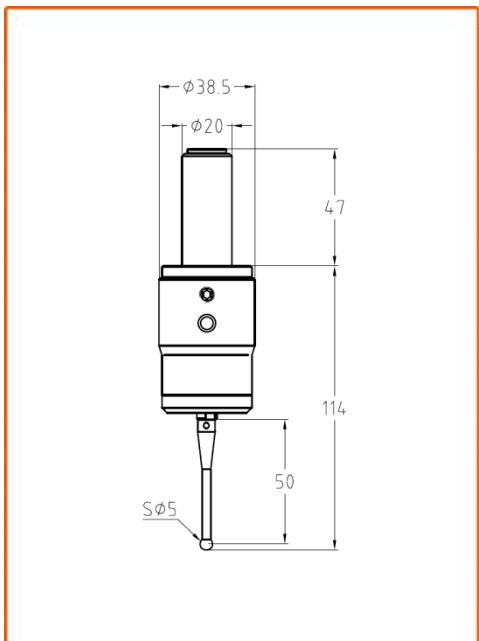
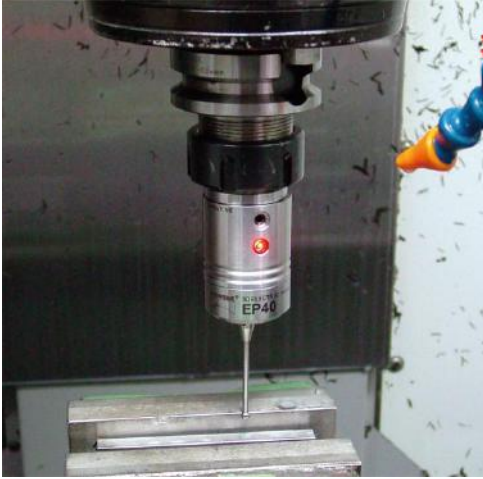

## Notes for purchase

- ◆ As for special stylus, check whether the standard stylus equipped with the EP40 probe can meet the requirements and whether it is necessary to order special stylus;
- ◆ Verify that the spindle of the CNC machine tool whether uses ceramic bearings. If ceramic bearings are used, You should choose the TP60 trigger probe.

## Technical Parameters

- ◆ Stylus sensing direction:  $\pm X, \pm Y, +Z$ ;
- ◆ Stylus sensing over-travel:  $X-Y \pm 15^\circ, Z +5 \text{ mm}$ ;
- ◆ The trigger force in Z direction: 1000 g;
- ◆ Trigger force in X-Y surface ( standard stylus ) : 65-130g;
- ◆ Unidirectional repeatability ( $2\sigma$ ) :  $\leq 2 \mu\text{m}$ ;
- ◆ Seal grade: IP68.

## Technical Characteristics

- ◆ Coaxial adjustment function of probe and shank:  
By adjusting the connecting link between the main body of the probe and its shank, coaxiality about the center of the measuring ball on the stylus and the center line of the shank can be adjusted (the factory precision:  $\leq 5 \mu\text{m}$ );
- ◆ Three LED indicator lights are used to show the trigger state of the probe.

## Basic configuration

- ◆ The standard: M4-S50-CB5-S30;
- ◆ The diameter of the probe's cylindrical shank is 20 mm;
- ◆ Two batteries, model: LR1, 1.5V, 700 mAh.

## Applicable equipment and working condition

- ◆ Suitable for various specifications of machine centers, CNC boring and milling machines, and drilling-tapping machine centers, etc;
- ◆ Suitable for checking work pieces of all kinds of solid materials with electrical conductivity.

## Application

- ◆ Setting work-piece coordinate system and machining zero points manually before processing;
- ◆ Detect and control the key dimensions, position coordinates and their precision manually between two processes;
- ◆ Detect precision of the key dimensions, shapes, position after processing.

## Composition of tool setter

TTC100 cable tool setter consists of a hardware and the software. The model of the software is SP-T10; the hardware also has two accessories:

- 1) 20 mm thick mounting base;
- 2) Blow- cleaning device (optional).

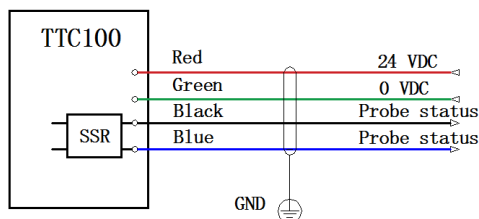
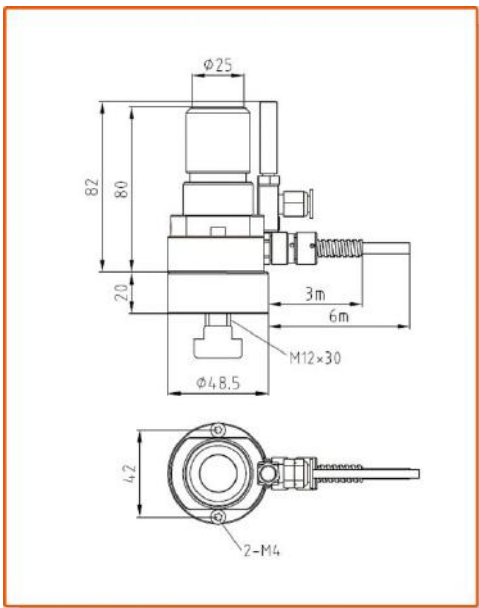

## Technical Parameters

- ◆ The nominal height of the TTC100 tool setter is 80mm, it is 100mm when the 20 mm thick mounting base added;
- ◆ The diameter of the touching face( for cutting tool touching): 25.0 mm, the hardness of the touch face: HRA 90-93;
- ◆ Travel distance of the touch face in -Z direction: 5 mm;
- ◆ Trigger repeatability of the tool setter(2 $\sigma$ ):  $\leq 2 \mu\text{m}$ ;
- ◆ Parallelism between the touch face and the bottom face of the tool setter for mounting :  $\leq 3 \mu\text{m}$ ;
- ◆ Input voltage is  $24 \pm 10\%$  V DC and output load current is 50 mA.
- ◆ Seal grade: IP68.

## Technical Characteristics

- ◆ Tool setter transmits signal through cable, reversal connecting tool setter's power supply can reverse the state of the output signal;
- ◆ There are two installing and fixing methods, one is to install directly, the other is to add a mounting base of 20mm thick, the tool setter's height can be raised from 80mm to 100mm.
- ◆ One LED indicator light is used to display the tool setter's working state.

## Application

- ◆ Set lengths parameter of cutting tools automatically before CNC processing;
- ◆ Detect wear and breakage of cutting tools automatically between two processes or after the CNC processing;
- ◆ Through checking cutting tool parameters to control the change of machining precision from the temperature change of the machine;
- ◆ Applicable equipments: various specifications of machine centers, CNC milling machines, drilling-tapping machine centers, etc;
- ◆ Tool setter's cable: TTC100 tool setter is equipped with 6m long, four-core, anti-oil shielding , moving cable and with a 3m-long stainless steel protecting sleeve.

## Notes for purchase

- ◆ As for the cable length, verify whether the cable length equipped is enough for installing the tool setter on your machine tool; If lengthening cable is needed, special instructions should be given when ordering the product;
- ◆ Verify whether you need blow-cleaning device or not, and whether there is a spare M code in the CNC system of your machine for controlling the blowing device.

## Composition of tool setter

TTC200 cable tool setter consists of a hardware and the software. The model of the software is SP-T10; the hardware also has a mounting base.

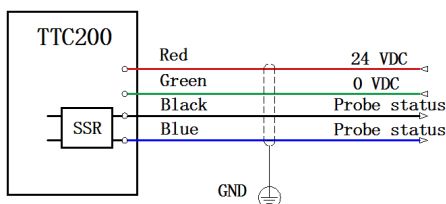
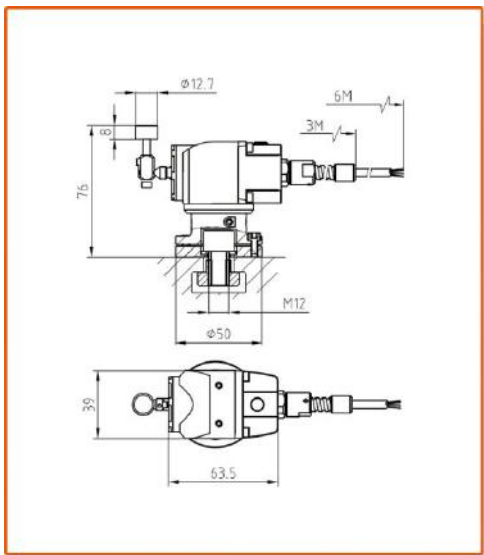
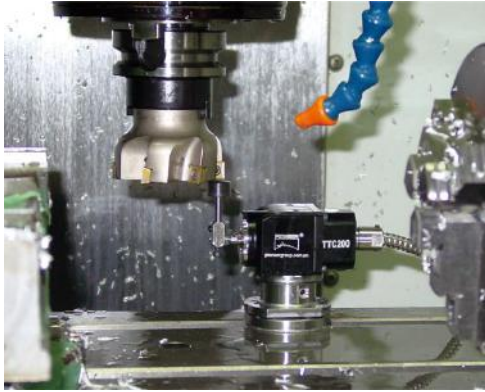

## Technical Parameters

- ◆ The diameter of the touching pillar( for cutting tool touching):  $12.7 \pm 0.005$  mm; the pillar's hardness : HM8.5 ;
- ◆ Sensing direction of the pillar:  $\pm X, \pm Y, -Z$ ;
- ◆ The trigger repeatability of the pillar( $2\sigma$ ):  $\leq 2 \mu\text{m}$ ;
- ◆ Input voltage is  $24 \pm 10\%$  V DC and output load current is 50 mA;
- ◆ Seal grade: IP68.

## Technical Characteristics

- ◆ Tool setter transmits signal through cable, reversal connecting tool setter's power supply can reverse the state of the output signal;
- ◆ The position of tool setter pillar can be roughly and precisely adjusted by the connecting link of the pillar and the adjusting link of tool setter for mounting.
- ◆ One LED indicator light is used to display the tool setter's working state.

## Application

- ◆ Set lengths parameter of cutting tools automatically before CNC processing;
- ◆ Detect wear and breakage of cutting tools automatically between two processes or after the CNC processing;
- ◆ Through checking cutting tool parameters to control the change of machining precision from the temperature change of the machine;
- ◆ Applicable equipments: various specifications of machine centers, CNC milling machines, drilling-tapping machine centers, etc;
- ◆ Tool setter's cable: TTC200 tool setter is equipped with 6m long, four-core, anti-oil shielding , moving cable and with a 3m-long stainless steel protecting sleeve.

## Notes for purchase

- ◆ As for the cable length, verify whether the cable length equipped is enough for installing the tool setter on your machine tool; If lengthening cable is needed, special instructions should be given when ordering the product;
- ◆ If the square pillar of tool setter is needed, customers should give special instructions when ordering the products.

## Installing structure of the unit

TTC400A cable tool setter unit is a product specially developed by our company for replacing some vulnerable tool setting units that is part of the swing-arm for setting the cutting tool in the CNC lathes; The structure and size of the installing parts are exactly the same as the replacement, and the output signal is exactly the same.

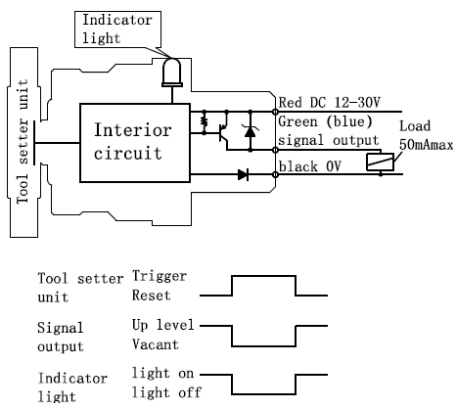
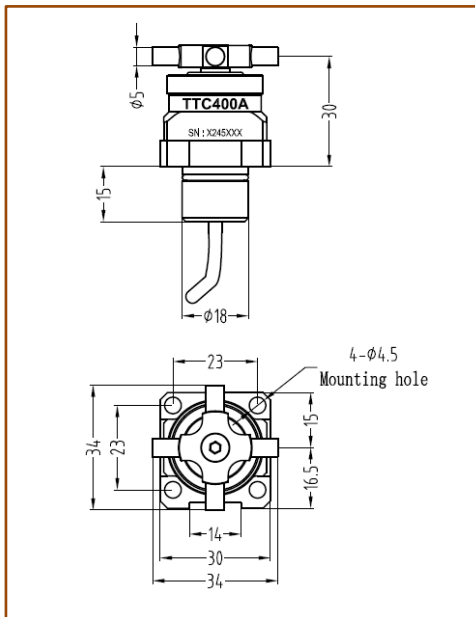
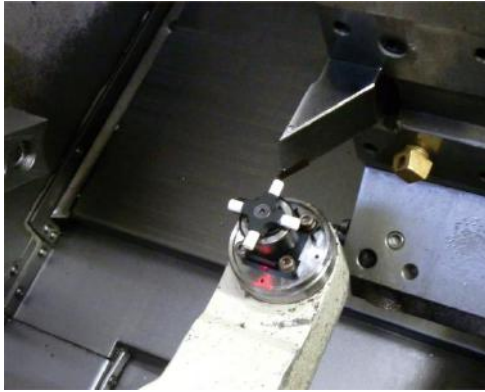

## Technical Parameters

- ◆ The diameter of the four ceramic touching pillar( for cutting tool touching): 5.0 mm; the pillars' hardness : HM8.5;
- ◆ Sensing direction of the pillars:  $\pm X, \pm Z$ ;
- ◆ The pillars sensing over-travel :  $X-Z \pm 5$  mm;
- ◆ The trigger repeatability of the pillar( $2\sigma$ ):  $\leq 2$   $\mu$ m;
- ◆ Input voltage is  $24 \pm 10\%$  V DC and output load current is 50 mA;
- ◆ Signal model and LED instruction: high electric level output with normal signal state, LED normally on; When any one pillar is triggered, the signal output point is suspended and the LED is off;
- ◆ Seal grade: IP68.

## Technical Characteristics

- ◆ As shown in the picture, the installing structure and size of the tool setter unit are exactly the same as the replacement;
- ◆ Tool setter unit transmits tool setting signal through cable;
- ◆ It is ensured during manufacturing that the position relationship between four pillars of the tool setter unit and mounting base;
- ◆ One LED indicator light is used to display the tool setter's working state.

## Application

- ◆ Set parameters of cutting tools automatically before CNC processing;
- ◆ Detect wear and breakage of cutting tools automatically between two processes or after the CNC processing;
- ◆ Through checking cutting tool parameters to control the change of machining precision from the temperature change of the machine;
- ◆ Applicable equipments: various specifications of CNC lathe, turning machine center and CNC milling -turning center;
- ◆ The cable: TTC400A tool setter unit is equipped a 6 meter-long, three-core, anti-oil shielded cable.

## Notes for purchase

- ◆ As for the cable length, verify whether the cable length equipped is enough for installing the tool setter unit on your machine tool; If lengthening cable is needed, special instructions should be given when ordering the product;

## TTC10 Portable Tool Setter

TTC10 tool setter is a kind of portable tool setter specially used to set the length parameter of cutting tool in the CNC milling machine, or drilling machine center and etc, it is especially suitable for single piece and a small batch of production.



### Technical Parameters

- ◆ Nominal height:  $80.0 \pm 0.003$  mm;
- ◆ Diameter of the touching face( for cutting tool touching): 30.0 mm;
- ◆ Hardness of the touch face: HRC 60-62;
- ◆ Travel distance of the touch face in -Z direction: 5 mm;
- ◆ Trigger repeatability of the tool setter( $2\sigma$ ):  $\leq 2$   $\mu$ m;
- ◆ The parallelism between the touching face and the bottom:  $\leq 3$   $\mu$ m;
- ◆ Seal grade: IP66.

### Technical Characteristics

- ◆ Applying two position indicators for warning to speed up the process of the cutting tool calibration;
- ◆ four Magnets inset in bottom of tool setter order to the tool setter with a adsorption capacity;
- ◆ It's powered by a battery, model: CR2, 3.0V, 800 mAh;
- ◆ Three LED indicator lights and a buzzer are used to indicate the working status of the tool setting.

### Application

- ◆ Set length parameters of cutting tools manually before CNC processing;
- ◆ Detect wear and breakage of cutting tools manually between two processes or after the CNC processing;
- ◆ Applicable equipments: machine centers, CNC boring machines, CNC milling machines, and drilling-tapping machine centers, etc;

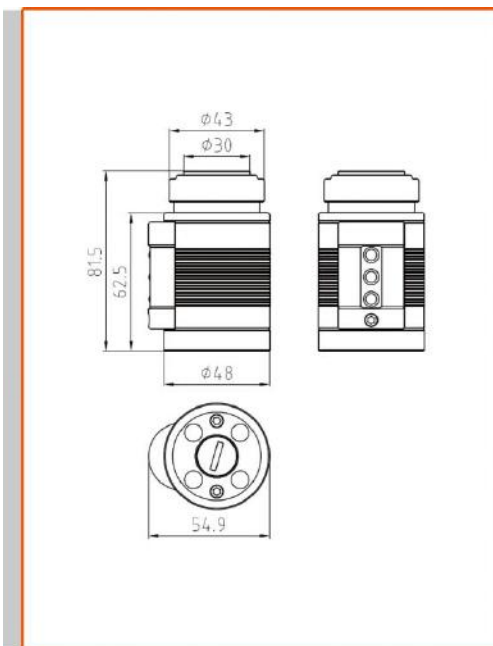

## Styli classification and application

- ◆ All kinds of styli needed for various probes used in CNC machine tool and the accessories needed for tool setters;
- ◆ All kinds of styli and accessories needed for various probes used in CMM;
- ◆ All kinds of styli and accessories needed for probes used in gear measuring machine;
- ◆ All kinds of styli and accessories needed by the other specially measuring equipment;
- ◆ For details, please refer to the product catalog of Styli And Accessories composed by our company alone.



The function of SP-W10 software package for work piece measuring (special for boring and milling machine)

- 1) Stylus' automatic calibration
- 2) Protection of stylus collision during a probe's movement
- 3) Groove and boss measurement

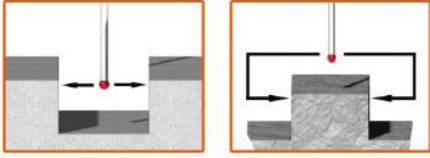

- 4) Bore and axis measurement

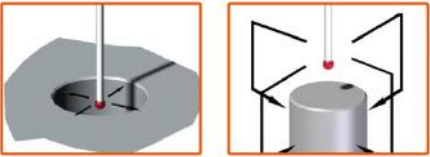

- 5) X,Y single-surface measurement



- 6) Internal corner and external corner measurement

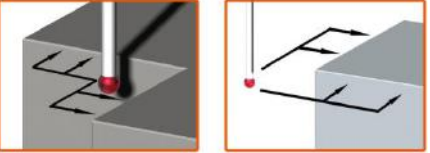

- 7) 4th axis measurement
- 8) The measurement of the angle on XY plane
- 9) Measure the three points on arc
- 10) Measure the distance between the two holes



The function of SP-W50 software package for work piece measuring (special for lathe)

- 1) Stylus' automatic calibration
- 2) Protection of stylus collision during a probe's movement
- 3) Measurement of convex circles and annular gro

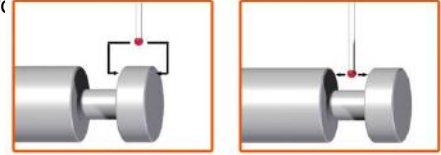

- 4) Bore and axis measurement

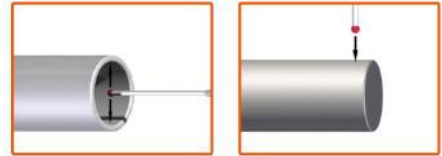

- 5) Measurement of the step plane with X and Y axes
- 6) Measurement of X-Z plane angle
- 7) Measurement of the internal arc on X-Z plane

The function of SP-T10 software package for cutting tool setting (special for boring and milling machine)

- 1) Calibrate the center of the tool setter automatically.
- 2) Setting standard tool length.
- 3) Semi - automatic tool length setting and full - automatic tool length setting

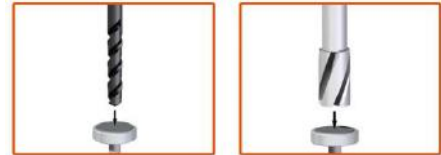

- 4) Semi - automatic tool diameter setting and full - automatic tool diameter setting



- 5) Automatic detection of tool wear and breakage





**PIONEER**



Harbin Pioneer M&E Technical  
Development Co., Ltd

Address: 1F, Building 4, Tianping Road 22, Daoli District,  
Harbin, China.

Postcode: 150078

Tel: +86 451 82330895/82285451-616/601

Fax: +86 451 82293947

Email: [sales@pioneergroup.com.cn](mailto:sales@pioneergroup.com.cn)

Http: [www.pioneergroup.com.cn](http://www.pioneergroup.com.cn)