

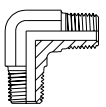

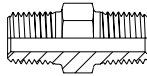

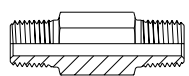

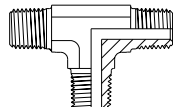

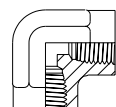
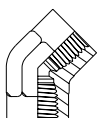
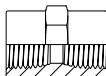
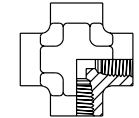
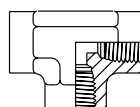
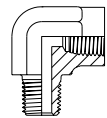
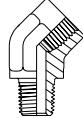
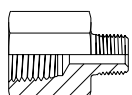
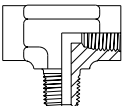
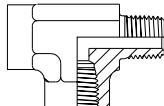
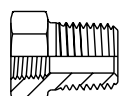

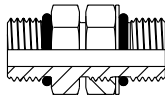
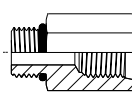
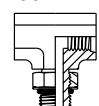
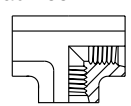
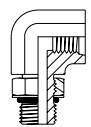
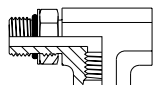

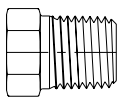
Industrial Pipe Fittings and Adapters



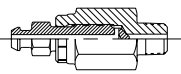
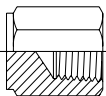
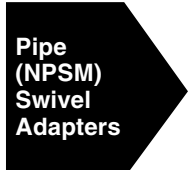
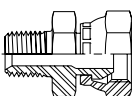
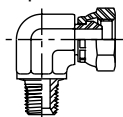
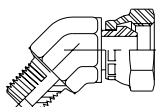

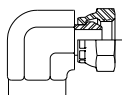
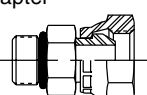
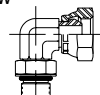



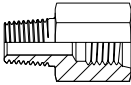
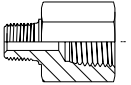
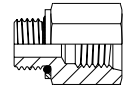
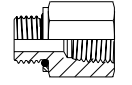
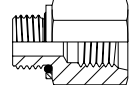
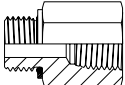
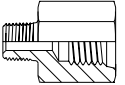
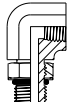
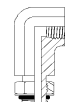
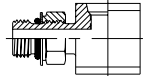
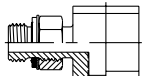
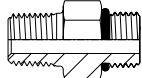
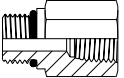
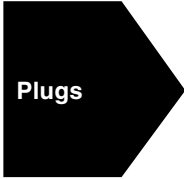

The Fitting Authority

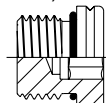
Visual Index

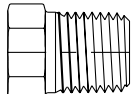
 <p>Industrial Pipe Fittings</p>	<p>CR Male Pipe Elbow</p>  <p>Page F15</p>	<p>FF Pipe Nipple</p>  <p>Page F16</p>	<p>FFF Long Pipe Nipple</p>  <p>Page F17</p>	<p>RRS Male Pipe Tee</p>  <p>Page F17</p>	<p>DD Female Pipe Elbow</p>  <p>Page F18</p>
<p>DD45 Female Pipe 45° Elbow</p>  <p>Page F18</p>	<p>GG Pipe Coupling</p>  <p>Page F19</p>	<p>KMMOO Female Pipe Cross</p>  <p>Page F19</p>	<p>MMO Female Pipe Tee</p>  <p>Page F20</p>	<p>CD Street Elbow</p>  <p>Page F20</p>	<p>CD45 Street Elbow 45°</p>  <p>Page F21</p>
<p>FG Expander / Adapter</p>  <p>Page F21</p>	<p>MMS Male Branch Tee</p>  <p>Page F22</p>	<p>MRO Male Run Tee</p>  <p>Page F22</p>	<p>PTR Pipe Thread Reducer</p>  <p>Page F23</p>	 <p>SAE Straight Thread Adapters</p>	<p>F50HAO Straight Thread Union</p>  <p>Page F24</p>
<p>F5OG5 Straight Thread Reducer / Expander</p>  <p>Page F25</p>	<p>G5G5JAO Straight Thread Branch Tee</p>  <p>Page F26</p>	<p>G5G5JG5 Female Straight Thread Tee</p>  <p>Page F26</p>	<p>AOEG5 Straight Thread Elbow</p>  <p>Page F27</p>	<p>AOG5JG5 Straight Thread Run Tee</p>  <p>Page F27</p>	
 <p>Caps, Plugs and Bleed Adapters</p>	<p>HHP Hollow Hex Pipe Plug</p>  <p>Page F28</p>	<p>HP Hex Head Pipe Plug</p>  <p>Page F28</p>	<p>HP5ON Hollow Hex Plug (SAE Straight Thread)</p>  <p>Page F29</p>	<p>P5ON Hex Head Plug (SAE Straight Thread)</p>  <p>Page F29</p>	<p>P5ONBA Straight Thread O-ring Bleed Adapter</p>  <p>Page F30</p>
<p>HPBA Male Pipe Bleed Adapter</p>  <p>Page F30</p>	<p>HPC NPTF Hex Pipe Cap</p>  <p>Page F30</p>	 <p>Pipe (NPSM) Swivel Adapters</p>	<p>0107 Male Pipe Adapter</p>  <p>Page F31</p>	<p>2107 Male Pipe Elbow</p>  <p>Page F32</p>	<p>3107 45° Male Pipe Elbow</p>  <p>Page F33</p>
<p>0207 Female Pipe Adapter</p>  <p>Page F33</p>	<p>2207 Female Pipe Elbow</p>  <p>Page F34</p>	<p>0507 Straight Thread Adapter</p>  <p>Page F34</p>	<p>2507 Straight Thread Elbow</p>  <p>Page F35</p>	<p>3507 45° Straight Thread Adapter</p>  <p>Page F35</p>	

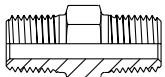
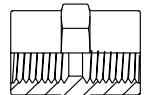
Note: For Metric and BSP Conversion Adapters shown here, see section I.

Conversion Adapters					
 <p>SAE Straight Thread to Pipe</p>	<p>F3HG5 Male BSPT/ Female SAE</p>  <p>Page I73</p>	<p>F3HG Male BSPT/ Female NPT</p>  <p>Page I73</p>	<p>F4OHG5 Male BSPP/ Female SAE</p>  <p>Page I74</p>	<p>F4OHG Male BSPP/ Female NPT</p>  <p>Page I74</p>	<p>F8OHG5 Male Metric/ Female SAE</p>  <p>Page I75</p>
<p>F8OHG Male Metric/ Female NPT</p>  <p>Page I75</p>	<p>FHG5 Male NPT/ Female SAE</p>  <p>Page I76</p>	<p>AOEG Male SAE/ Female NPT</p>  <p>Page I76</p>	<p>AOE4G Male SAE/Female NPT-Long Elbow</p>  <p>Page I77</p>	<p>A87LPOEG87LPM Male ISO 6149 Female ISO 6149</p>  <p>Page I79</p>	<p>A4OEG4M Male BSPP Female BSPP</p>  <p>Page I79</p>
<p>F50F Male SAE/ Male NPT</p>  <p>Page I77</p>	<p>F50G Male SAE/ Female NPT</p>  <p>Page I78</p>	 <p>Plugs</p>	<p>P87OMN Hex Head Plug (ISO 6149)</p>  <p>Page I80</p>	<p>VSTI M-OR Hollow Hex Plug (ISO 6149)</p>  <p>Page I81</p>	<p>VSTI M-ED Hollow Hex Plug (Metric DIN 3852)</p>  <p>Page I80</p>
<p>VSTI R-ED Hollow Hex Plug (BSPP DIN 3852)</p>  <p>Page I81</p>	<p>HP3M BSPT Hex Head Pipe Plug</p>  <p>Page I85</p>	 <p>BSP Adapters</p>	<p>FF33M BSPT Pipe Nipple</p>  <p>Page I82</p>	<p>GG44M BSPP Pipe Coupling</p>  <p>Page I82</p>	<p>RI-ED BSPP Reducing Adapter/Expander</p>  <p>Page I83</p>
<p>RI BSPP Reducing Adapters/Expander</p>  <p>Page I84</p>					

F

Note: For Metric and BSP Conversion Adapters shown here, see section I.

Introduction

There are many types of threads used throughout the world. This Section contains adapters with just a few of those many thread types including: NPT, NPTF, NPSM, BSPT, BSPP, SAE UN/UNF, and Metric. All the threads in this section are made to industry specifications with conformance shown in [Table F1](#).

Thread	Standard
NPT	ANSI B1.20.1, FED-STD-H28/7
NPTF	SAE J476, ANSI B1.20.3, FED-STD-H28/8
NPSM	ANSI B1.20.1, FED-STD-H28/7
BSPT	BS 21, ISO 7/1
BSPP	BS 2779, ISO 228/1
Metric	ISO 261, ANSI B1.13M, FED-STD-H28/21
UN/UNF*	ANSI B1.1, FED-STD-H28/2

*Class 2A or 2B

Table F1 — Thread Conformance Standards

The next few pages describe the application and assembly methods for the adapters using the various threads above.

Design and Construction

Shaped products (elbows, tees and crosses) are hot forged and machined, while straights are manufactured from cold drawn barstock. Where applicable, these products are made in conformance with the design criteria of the society of Automotive Engineers Standards, SAE J514, J530.

Standard material Specifications: The standard materials used in the manufacture of Industrial Pipe and Adapter fittings are shown in [Table F2](#).

Pipe Fittings, Adapters and	Steel		Stainless Steel		Brass	
	ASTM	Type	ASTM	Type	ASTM	Type
Forged Bodies	A576	1214/1215	A182	316	B124	CA377
Bar Stock Bodies	A108	12L14	A479	316	B16 B453	CA360 CA345

Table F2 — Standard Material Specifications for Industrial Pipe Fittings and Adapters

Note: Upon request, pipe fittings, adapters and plugs could be furnished in materials other than those shown in the materials specifications chart.

Parker Fluid Connector products made from steel and brass, for the most part, have NPTF threads. Stainless steel products may have NPT or slightly modified NPT threads to minimize the chance of galling on assembly.

Finish - Zinc with Yellow Chromate is used on all standard steel products. Stainless steel fittings are passivated.

Industrial Pipe Fittings (NPT and NPTF)

How Tapered Pipe Threads Work

Industrial Pipe Fittings use NPT and NPTF (Dryseal) tapered pipe threads. These threads feature a 60° flank angle and 1°47' taper, as shown in [Fig. F1](#).

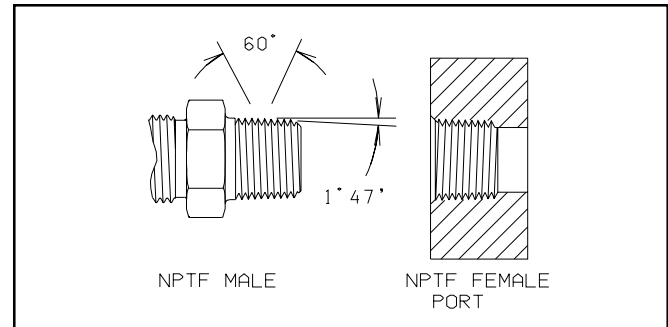

Fig. F1 — Dryseal American Standard Taper Pipe Thread — NPTF

How A Leak Free Joint Is Achieved

NPT threads, when assembled without a sealant, leave a spiral leak path at the crest-root junction as shown in [Fig. F2](#). To seal pressurized fluid, NPT threads need a suitable sealer.

NPTF threads (Dryseal), on the other hand, when assembled, do not leave such spiral leak path. This is because they have controlled truncation at the crest and root, ensuring metal to metal crest-root contact prior to, or just as the male-female thread flanks make contact as seen in [Fig. F3](#). Upon further tightening, the thread crests are flattened out until the flanks also make metal to metal contact as seen in [Fig. F4](#). Thus, theoretically at least, there is no passage left for the fluid to leak, provided all surfaces are flawless and dimensions exact. In the real world, however, this is not the case and a sealant/lubricant is necessary to achieve a leak free joint even with NPTF threads. The sealant/lubricant fills all imperfections in the surfaces affecting the seal and provides lubrication to ease assembly and minimize galling.

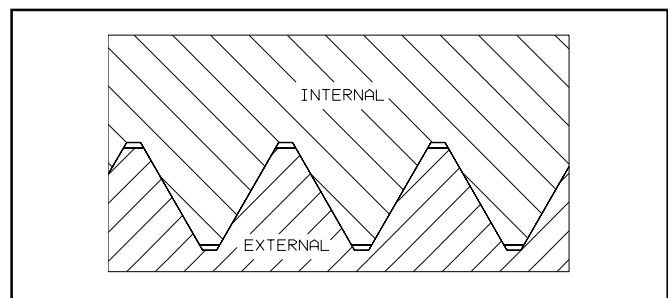

Fig. F2 — NPT — Wrench Tight-No Crest-Root Contact, Flank Contact Only

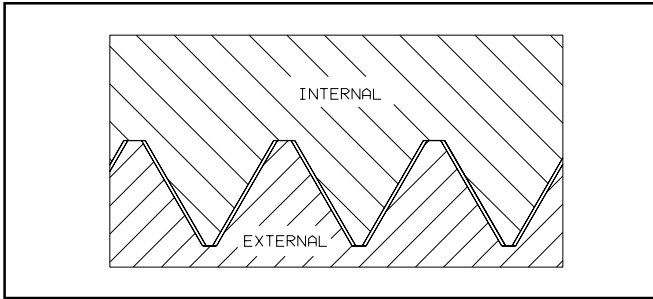

Fig. F3 — NPTF — Hand Tight-Crest to Root Contact

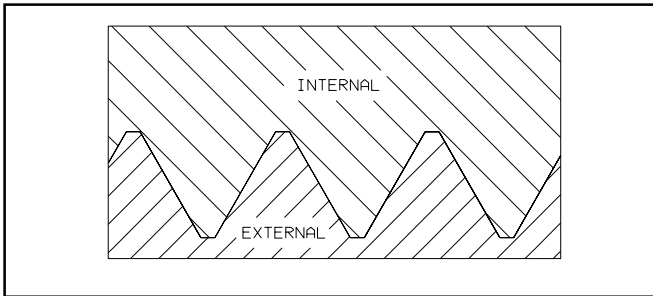

Fig. F4 — NPTF — Wrench Tight-Crest to Root and Flank Contact

It is easier to obtain a seal with NPTF threads than it is with NPT threads because of the metal to metal contact along the full thread profile. Therefore, they are preferred over NPT in high pressure hydraulic applications.

Type of Sealant/Lubricant

Sealant/Lubricants assist in sealing and provide lubrication during assembly, reducing the potential for galling. Pipe thread sealants are available in various forms such as dry pre-applied, tape, paste and anaerobic liquid.

Pre-applied sealants, such as “Vibraseal” (registered trademark of Loctite Corporation) and powdered PTFE are usually applied to connectors by the manufacturer. Connectors with some of these sealants may be remade a few times without needing additional sealant. Vibraseal may also help reduce loosening due to vibration.

PTFE tape, if not applied properly, can contribute to system contamination during assembly and disassembly. In addition, because of PTFE’s high lubricity, fittings can be more easily over tightened; and it does not offer much resistance to loosening under vibration.

Paste sealants can also contribute to system contamination, if not applied properly. They are also messy to work with; and some types require a cure period after component installation, prior to system start up.

Anaerobic liquids are available from several manufacturers and perform sealing as well as thread locking functions. They are applied to the connectors by the user and require a cure period prior to system start up. Some are soluble in common hydraulic fluids and will not contaminate the system. For proper performance they need to be applied to clean and dry components, carefully following the manufacturer’s directions.

For proper application of the sealants see assembly on [page A43](#), and follow the manufacturer’s recommendation.

Pressure Holding Capacity

Dryseal taper pipe threads have the highest strength of any commonly used port connection to withstand static pressure load (blow-off resistance). This pressure holding capacity depends mainly on the following factors:

- Strength of connectors and port materials.
- Total number of threads engaged.
- Quality of threads of the mating parts.

Extensive testing has been conducted by the Fluid Connector Divisions of Parker to determine the pressure at which failure occurred in the form of leakage or burst with pipe threaded (NPTF) joints. Tests were conducted on production parts made from low carbon steel forgings as well as barstock, using hardened steel test blocks for male threads and low carbon steel plugs for female threads.

Sealing of Pipe Threads

Pipe threads have very high pressure holding (blow-off resistance) capability. However, their ability to create and maintain seal in a dynamic (high cycle pulsating with attendant shocks and vibration) applications depends on many factors, including the following:

- Quality of threads (surface, form and dimensions) of both the port and the connector.
- Type and application of the sealant.
- Joint tightness.
- Port and connector material combination (difference in thermal expansion).
- Severity of application — amount and severity of vibration, shocks (hydraulic as well as mechanical) and thermal cycling involved.
- Procedure followed in positioning (orienting) shaped connectors.
- Sensitivity of female pipe threads in shaped connectors to over tightening.
- Number of times the joint is re-assembled and the extent to which proper procedure is followed.
- Clamping and routing.

The more of the above factors that are involved in making a connection, the greater is its propensity for leakage. Thus, the propensity for leakage of a pipe threaded joint can vary from extremely low to very high depending on its favorable/unfavorable mix of the above factors in an application.

Past experience has shown and extensive testing has confirmed that:

- Connectors with larger pipe threads have a higher tendency to leak than those with smaller ones. This is because larger threads have more chances for surface imperfections and dimensional inaccuracies; and, being heavier, they are more prone to handling damage. They probably don’t always get tightened properly as they require larger wrench clearances and more effort.
- Connectors with female pipe threads have a higher tendency to leak than those with male pipe threads. This is because female pipe threads machined in connectors tend to expand under pressure spikes and repeated assembly, causing eventual loss of seal.

Technical Data

(c) Shaped connectors with pipe threads have a higher tendency to leak than straight ones because shapes are apt to see higher loosening moments (hose pull, accidental bumping, etc.) than straight ones. They are also more prone to handling damage than straight ones because the forgings are softer than the barstock. Brazed connectors are more susceptible to damage than forged ones due to their even softer (HRB 50-60) condition. Also, it is difficult to always tighten shapes with pipe threads to an optimum tightness level because of orientation requirements.

Thus, connectors with pipe threads, except for straight ones with 3/4-14 NPTF and smaller male pipe threads, have low reliability for leak free operation in dynamic applications. Therefore, where no leakage can be tolerated, SAE straight thread (SAE J1926/ISO 11926), SAE four bolt split flange (SAE J518/ISO 6162) and ISO 6149 port connections are recommended.

Recommended Working Pressures

Some manufactures rate their pipe threaded products very aggressively, i.e. they use one value for all products with pipe threads of a given size, based on burst/leakage tests with male threaded barstock parts. These are very misleading and can lead to leakage or even more serious problems.

We believe the correct way to rate the pipe threads is by taking into consideration the type of product (barstock or forged with male or female threads) and severity of the application.

Working pressures for pipe threaded ends of connectors are arrived at by applying a design factor, based on severity of application. The pressure tables are based on these factors,

Application Guidelines

As seen in the pressure tables, straight connectors with 3/4-14 NPTF and smaller male pipe threads have very high pressure holding capability and seal reliability when used in applications without make and break (such as maintenance) requirements. They are also well suited for low cycle non-pulsating applications with pressures in excess of 6,000 psi.

As noted earlier, connectors with pipe threads, except for straight connectors with 3/4-14 NPTF and smaller male pipe threads, have low reliability for leak free operation in dynamic applications. Therefore, they are not preferred where a leak free joint is required.

While a pipe thread connection can be disassembled and re-assembled in low pressure systems, it is not intended to be a make and break connection. When connectors are known to be disassembled and re-assembled repeatedly, pipe connections are not preferred for high pressure systems.

For the above applications, a port connection with an elastomeric seal, such as SAE straight thread port (SAE J1926/ISO 11979) or SAE four bolt split flange (SAE J518/ISO 6162) and ISO 6149 is recommended.

For application where sealants can't be used, consult the manufacturer.

Assembly

Please refer to [pages A41 through A43](#) for recommended assembly procedures for the pipe and straight thread products shown in this section. See [Table F3](#) for pipe thread assembly Turns From Finger Tight values.

Pipe Thread Size NPTF	T.F.F.T.
1/8 - 27	2 - 3
1/4 - 18	2 - 3
3/8 - 18	2 - 3
1/2 - 14	2 - 3
3/4 - 14	2 - 3
1 - 11 1/2	1.5 - 2.5
1 1/4 - 11 1/2	1.5 - 2.5
1 1/2 - 11 1/2	1.5 - 2.5
2 - 11 1/2	1.5 - 2.5

Table F3 — Assembly Turns From Finger Tight (T.F.F.T) Values For Steel, Stainless Steel and Brass Pipe Threads

Trouble Shooting Guide

Problem	Solution
There is no sealant used or sealant has worn thin.	Apply new sealant and re-tighten to specification.
Threads are galled.	Replace fitting and/or component.
Fitting screws in too far into the port.	Port opened up or cracked Replace component.
Threads are severely nicked.	Replace fitting.
Seals initially but vibrates loose after some time.	Replace with SAE straight thread port.

Table F4 — Industrial Pipe Fittings and Adapters Trouble Shooting Hints

Features, Advantages & Benefits

- 1. Compact Size** — Pipe port and end provide very compact connection — especially useful in tight places.
- 2. Adaptability** — Pipe fittings can be used in systems using pipe or tubing.
- 3. High Temperature Capability** — Metal to metal sealing makes pipe fittings especially suitable for low pressure, high temperature applications.
- 4. Wide Spread General Use** — Pipe fittings are the oldest of all fittings used in varied applications ranging from household plumbing to high technology instrumentation. They are especially suited for low pressure general use such as air, water, gas, oil and chemical processing.
- 5. Availability** — Pipe fittings and adapters are readily available in a broad range of sizes, materials and configurations.

SAE Straight Thread Adapters

How Do SAE Adapters Work

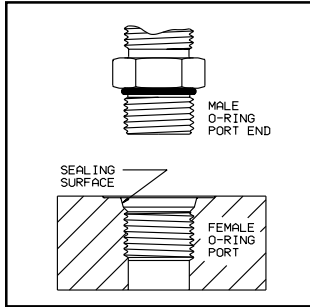

Fig. F5 — SAE Straight Thread O-ring Port

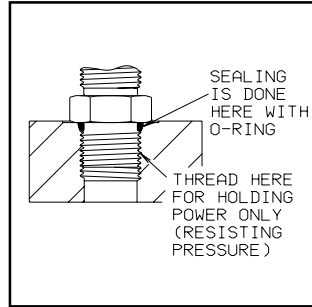

Fig. F6 — SAE Straight Thread O-ring Port Assembly

Parker fittings incorporating SAE Straight Thread O-Ring port studs shown in this section are for connection with the SAE Straight Thread port (SAE J1926/1, ISO 11926) as shown on [page A19](#) in the General Technical section. When properly assembled, they provide the best leak-free port connection available.

Basic port machining dimensions for this industry standard port are given on [page A19](#) in the General Technical Section. For counterbore and thread tapping tools for this port see [page N50](#) in the Tube Fabrication Equipment section.

Assembly

The assembly procedure for the SAE Straight Thread port connection can be found in the [General Technical Section, Section A](#). The tightening torque values for SAE Straight Thread Connectors can be found on the subsequent tables.

SAE Straight Thread Adjustable Fitting (Steel)			
SAE Port Size	SAE Port Thread Size	Assembly Torque	
		in. lbs.	ft. lbs.
2	5/16 - 24	65 ± 5	5.5 ± 0.5
3	3/8 - 24	130 ± 10	11 ± 1.0
4	7/16 - 20	170 ± 10	14 ± 1.0
5	1/2 - 20	260 ± 15	22 ± 1.0
6	9/16 - 18	320 ± 20	27 ± 2.0
8	3/4 - 16	500 ± 25	42 ± 2.0
10	7/8 - 14	720 ± 30	60 ± 2.5
12	1 1/16 - 12	960 ± 50	80 ± 5.0
14	1 3/16 - 12	1260 ± 75	105 ± 6.0
16	1 5/16 - 12	1380 ± 75	115 ± 6.0
20	1 5/8 - 12	2700 ± 150	225 ± 12.0
24	1 7/8 - 12	3000 ± 150	250 ± 12.0
32	2 1/2 - 12	3900 ± 200	325 ± 15.0

Table F5 — Port End Assembly Torques for SAE Straight Thread O-Ring Adjustable Fittings

Note: Assembly torque — use upper limits of torque ranges for stainless steel fittings. Values in above chart are for lubricated assemblies. Lubricant is strongly recommended for threads, o-rings and contact surfaces of stainless steel assemblies.

SAE Straight Thread Non-Adjustable Fitting (Steel)			
Fitting Size	SAE Port Thread Size	Assembly Torque	
		in. lbs.	ft. lbs.
2	5/16 - 24	90 ± 5	7.5 ± 0.5
3	3/8 - 24	170 ± 10	14 ± 1.0
4	7/16 - 20	220 ± 15	18 ± 1.0
5	1/2 - 20	260 ± 15	22 ± 1.0
6	9/16 - 18	320 ± 20	27 ± 2.0
8	3/4 - 16	570 ± 25	48 ± 2.0
10	7/8 - 14	1060 ± 50	90 ± 5.0
12	1 1/16 - 12	1300 ± 50	110 ± 5.0
14	1 3/16 - 12	1750 ± 75	145 ± 6.0
16	1 5/16 - 12	1920 ± 25	160 ± 6.0
20	1 5/8 - 12	2700 ± 150	225 ± 12.0
24	1 7/8 - 12	3000 ± 150	250 ± 12.0
32	2 1/2 - 12	3900 ± 200	325 ± 15

Table F6 — Port End Assembly Torques for SAE Straight Thread O-Ring Non-Adjustable Fittings

Note: Assembly torque — use upper limits of torque ranges for stainless steel fittings. Values in above chart are for lubricated assemblies. Lubricant is strongly recommended for threads, o-rings and contact surfaces of stainless steel assemblies.

SAE Straight Thread O-ring Plugs (Steel)					
Fitting Size	SAE Port Thread Size	Hollow Hex Head Plug (HP5ON) Assembly Torque		Hex Head Plug (P5ON) Assembly torque	
		in. lbs.	ft. lbs.	in. lbs.	ft. lbs.
2	5/16 - 24	35 ± 5	3 ± .5	90 ± 5	7.5 ± .5
3	3/8 - 24	60 ± 5	5 ± .5	170 ± 10	14 ± 1
4	7/16 - 20	135 ± 10	11 ± 1	220 ± 15	18 ± 1
5	1/2 - 20	180 ± 10	15 ± 1	260 ± 15	22 ± 1
6	9/16 - 18	220 ± 10	18 ± 1	320 ± 20	27 ± 2
8	3/4 - 16	550 ± 20	46 ± 2	570 ± 25	48 ± 2
10	7/8 - 14	900 ± 50	75 ± 5	1060 ± 50	90 ± 5
12	1 1/16 - 12	1020 ± 50	85 ± 5	1300 ± 50	110 ± 5
14	1 3/16 - 12	1550 ± 75	130 ± 6	1750 ± 75	145 ± 6
16	1 5/16 - 12	1600 ± 75	135 ± 6	1920 ± 75	160 ± 6
20	1 5/8 - 12	2700 ± 150	225 ± 12	2700 ± 150	225 ± 12
24	1 7/8 - 12	3000 ± 150	250 ± 12	3000 ± 150	250 ± 12
32	2 1/2 - 12	3900 ± 200	325 ± 15	3900 ± 200	325 ± 15

Table F7 — Port Assembly torques for Straight Thread O-ring Plugs



**Trouble Shooting Guide —
 SAE Straight Thread**

Problem	Solution
Leakage from port	O-Ring missing or torn. Replace with new O-Ring and retighten to appropriate specification.
Leakage from port	Fitting not tightened properly, tighten to appropriate specification.
Leakage from port	Adjustable stud not assembled properly, repeat with appropriate assembly procedure as outlined in General Technical Section, Section A. Tighten to appropriate torque specification.
Fitting vibrates loose	Re-evaluate system: clamping, routing, stressed joint, etc.
Threads damaged	Replace fitting and/or component.

Table F8 — SAE Straight Thread Trouble Shooting Hints

**Features, Advantages and Benefits —
 SAE Straight Thread**

- Elastomeric Seal** — SAE Straight Thread O-Ring connections offer a high seal reliability, especially in dynamic and shock loading applications. The O-Ring seal offers a high tolerance to minor surface imperfections and damage.
- Infinite Positioning of Shaped Fittings** — Due to the design of shaped fittings incorporating adjustable SAE Straight Thread connections, they allow for infinite positioning of the port end. Aligning for tube and hose connections is much easier as compared to tapered pipe threads/ports. Female and male thread damage is diminished as well because SAE Straight Threads do not incorporate the metal to metal thread sealing of tapered threads.
- Reusability** — Since the sealing and mechanical holding functions are separated, the SAE Straight Thread male studs can be re-used many times simply by changing the O-ring.

Pipe (NPSM) Swivel Adapters

How Do NPSM Swivels Work?

NPSM swivel adapters are for use with male NPT/NPTF hose fittings with a 30° seat. NPSM adapters do not seal on the threads like most pipe threads, they seal on the nose of the NPSM swivel and the seat on the male NPT/NPTF pipe thread. This creates a metal to metal seal as shown in Fig. F7.

Assembly

The most important preparation prior to assembly is to make certain that the mating male NPT/NPTF pipe thread has a 30° seat as shown in Fig. F8.

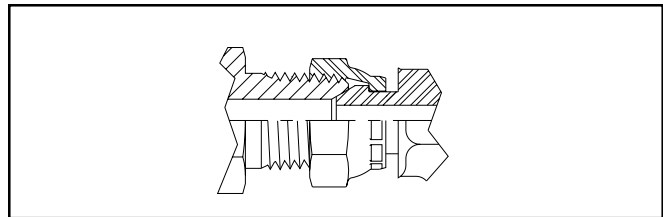

Fig. F7 — Illustration showing how NPSM swivel adapters seal on mating chamfer in male pipe thread.

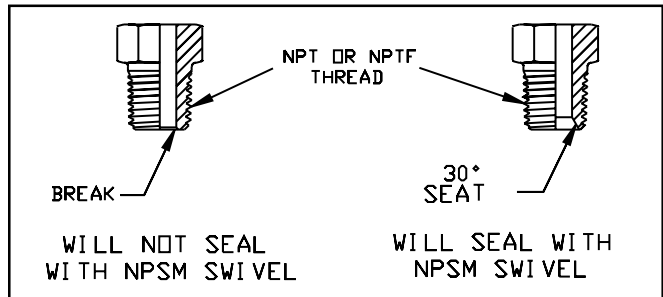

Fig. F8 — Illustration showing the required 30° seat on NPT/NPTF threads for NPSM swivel to seal

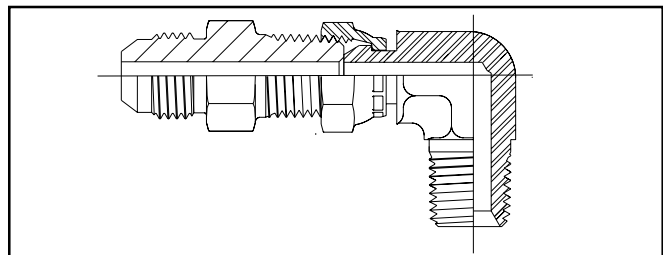

Figure F9 — Chamfer of NPT/NPTF male thread does not provide appropriate contact for a reliable seal with cone of NPSM swivel.

A chamfer or break will not suffice as a sealing surface (Fig. F9). A full internal 30° seat is required with a typical surface of 125 Ra. See SAE J516 for complete dimensional and other requirements.

Inspect both the NPSM swivel adapter and mating male NPT/NPTF seat for any visible burrs, nicks, or thread damage. These problems may inhibit a tight connection and sealing.

Final Assembly

Thread the NPSM swivel end onto the male NPT/NPTF end until finger tight. The NPSM swivel should thread completely onto the male NPT/NPTF thread, until the male and female seats mate. The threads should not become tight before seats mate. To assure seat-to-seat contact, check for relative movement between the two fittings by “rocking” or rotating the fittings. If possible, “rock” or rotate the fittings, re-tighten until there is no relative movement. Next, tighten the swivel nut connection using the Flats From Finger Tight values shown in the Table F9. (Note: The use of pipe thread sealants, TFE tape or other adhesives is neither required nor recommended to ensure a leak-free connection.) The torque values are provided for reference only.

Technical Data

NPSM Size in.	Steel Assembly			Stainless Steel
	Torque (+10%, -0%)		F.F.F.T.	Assembly
	in.-lbs.	ft.-lbs.		F.F.F.T.
1/8	108	9	1.0 – 1.5	1.0 – 1.5
1/4	156	13	1.0 – 1.5	1.0 – 1.5
3/8	192	16	1.0 – 1.5	1.0 – 1.5
1/2	396	33	1.0 – 1.5	1.0 – 1.5
3/4	516	43	1.0 – 1.5	1.0 – 1.5
1	696	58	1.0 – 1.5	1.0 – 1.5
1 1/4	1320	110	1.0 – 1.5	1.0 – 1.5
1 1/2	2520	210	1.0 – 1.5	1.0 – 1.5
2	3720	310	1.0 – 1.5	1.0 – 1.5

Table F9 — Assembly values for NPSM (Parker 07) swivel connections

Notes:

1. Assembly Torque — Torque are for lubricated carbon steel fittings only.
2. F.F.F.T. — The flats from finger tight assembly method is recommended for steel, stainless steel or brass fittings.
3. F.F.F.T. — For stainless steel fittings, a suitable lubricant should be applied to contacting surfaces. Permatex Anti-Seize Lubricant is recommended.
4. F.F.F.T. (Flats From Finger Tight) — In the correct initial reference position, the angular male seat of swivel connector must be seated and in light contact with 30° female surface of fitting for hose connector body. If necessary, a wrench should be used to pull nut and seats to this initial reference position. For final assembly, the nut should now be tightened to the appropriate number of F.F.F.T. as shown in chart. Where necessary, a second wrench should be used to prevent unwanted rotation of fitting body, hose connector stem, etc.
4. Assembly Torque & F.F.F.T. — Torque and F.F.F.T. values shown in the chart are for use with compatible fittings and connectors from Parker Hannifin Corporation.

F

Recommended Working Pressure, PSIG

These recommended working pressures represent the capability of the subject fitting. Nevertheless, in some instances, the wall thickness or type of tubing, hose, or hose connector, assembled to the fitting may dictate the maximum pressure to which the assembly should be exposed. It is strongly suggested that these fitting working pressure charts be used in conjunction with appropriate pressure charts for tubing or hose during the fitting selection process.

Refer to the definition of pressure rated static and pressure rated dynamic. The following values are based on a minimum design factor of 4:1 for dynamic and 3:1 for static applications.

Pressure, Rated Static – The maximum pressure that a pressure containing envelope is capable of sustaining in an application not exceeding 30,000 operating cycles in a system free of pressure surges, shocks, vibration, and temperature excursions.

Pressure, Rated Dynamic – The maximum fluctuating pressure load that a pressure containing envelope is capable of sustaining for a minimum of one million operation cycles without failure.

SIZE	STATIC			DYNAMIC		
	STEEL	SS	BRASS	STEEL	SS	BRASS
	1/8	7000	7000	4550	5000	5000
1/8 X 1/4	7000	7000	4550	5000	5000	3250
1/4 X 1/8	7000	7000	4550	5000	5000	3250
1/4 X 3/8	6000	6000	3900	4500	4500	2925
1/4	7000	7000	4550	5000	5000	3250
1/4 X 1/2	4000	4000	2600	3000	3000	1950
3/8 X 1/8	7000	7000	4550	5000	5000	3250
3/8 X 1/4	7000	7000	4550	5000	5000	3250
3/8 X 1/2	4000	4000	2600	3000	3000	1950
3/8	6000	6000	3900	4500	4500	2925
1/2 X 1/8	7000	7000	4550	5000	5000	3250
1/2 X 1/4	7000	7000	4550	5000	5000	3250
1/2 X 3/8	6000	6000	3900	4500	4500	2925
1/2	4000	4000	2600	3000	3000	1950
3/4 X 1/4	5500	5500	3575	4000	4000	2600
3/4 X 3/8	5500	5500	3575	4000	4000	2600
3/4 X 1/2	4000	4000	2600	3000	3000	1950
3/4	4000	4000	2600	3000	3000	1950
1 X 1/4	4000	4000	2600	3000	3000	1950
1 X 3/8	4000	4000	2600	3000	3000	1950
1 X 1/2	4000	4000	2600	3000	3000	1950
1 X 3/4	4000	4000	2600	3000	3000	1950
1	2250	2250	1463	1750	1750	1138
1 1/4 X 3/4	3000	3000	1950	2500	2500	1625
1 1/4 X 1	2250	2250	1463	1750	1750	1138
1 1/4	2000	2000	1300	1500	1500	975
1 1/2 X 1	2250	2250	1463	1750	1750	1138
1 1/2 X 1 1/4	2000	2000	1300	1500	1500	975
1 1/2	2000	2000	1300	1500	1500	975
2 X 1 1/2	2000	2000	1300	1500	1500	975
2	1250	1250	813	1000	1000	650

* Shaped connectors (elbows, tees and crosses) with pipe threads have low reliability for leak free operation in dynamic systems. For total leak free reliability in such systems, connectors with o-ring sealing such as SAE straight thread or SAE four bolt split flange are recommended.

SIZE	STATIC			DYNAMIC		
	STEEL	SS	BRASS	STEEL	SS	BRASS
	1/8	10000	12000	6500	6000	6000
1/4 X 1/8	9500	11400	6175	6000	6000	3900
1/4	9500	11400	6175	6000	6000	3900
3/8 X 1/8	8000	9600	5200	6000	6000	3900
3/8 X 1/4	8000	9600	5200	6000	6000	3900
3/8	8000	9600	5200	6000	6000	3900
1/2 X 1/8	6500	7800	4225	5000	6000	3250
1/2 X 1/4	6500	7800	4225	5000	6000	3250
1/2 X 3/8	6500	7800	4225	5000	6000	3250
1/2	6500	7800	4225	5000	6000	3250
3/4 X 1/8	5500	6600	3575	4000	4800	2600
3/4 X 1/4	5500	6600	3575	4000	4800	2600
3/4 X 3/8	5500	6600	3575	4000	4800	2600
3/4 X 1/2	5500	6600	3575	4000	4800	2600
3/4	5500	6600	3575	4000	4800	2600
1 X 1/8	4000	4800	2600	3000	3600	1950
1 X 1/4	4000	4800	2600	3000	3600	1950
1 X 3/8	4000	4800	2600	3000	3600	1950
1 X 1/2	4000	4800	2600	3000	3600	1950
1 X 3/4	4000	4800	2600	3000	3600	1950
1	4000	4800	2600	3000	3600	1950
1 1/4 X 1/4	3000	3600	1950	2500	3000	1625
1 1/4 X 3/8	3000	3600	1950	2500	3000	1625
1 1/4 X 1/2	3000	3600	1950	2500	3000	1625
1 1/4 X 3/4	3000	3600	1950	2500	3000	1625
1 1/4 X 1	3000	3600	1950	2500	3000	1625
1 1/4	3000	3600	1950	2500	3000	1625
1 1/2 X 1/4	3000	3600	1950	2000	2400	1300
1 1/2 X 3/8	3000	3600	1950	2000	2400	1300
1 1/2 X 1/2	3000	3600	1950	2000	2400	1300
1 1/2 X 3/4	3000	3600	1950	2000	2400	1300
1 1/2 X 1	3000	3600	1950	2000	2400	1300
1 1/2 X 1 1/4	3000	3600	1950	2000	2400	1300
1 1/2	3000	3600	1950	2000	2400	1300
2 X 1/2	3000	3600	1950	2000	2400	1300
2 X 3/4	3000	3600	1950	2000	2400	1300
2 X 1	3000	3600	1950	2000	2400	1300
2 X 1 1/4	3000	3600	1950	2000	2400	1300
2 X 1 1/2	3000	3600	1950	2000	2400	1300
2	3000	3600	1950	2000	2400	1300

Recommended Working Pressure, PSIG

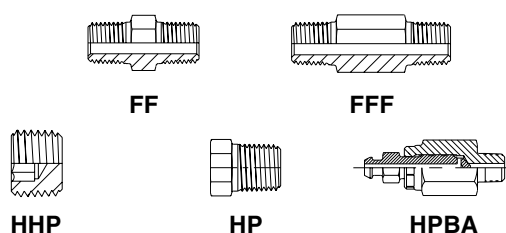

SIZE	STATIC			DYNAMIC		
	STEEL	SS	BRASS	STEEL	SS	BRASS
1/16	10000	12000	6500	6000	7200	3900
1/8	10000	12000	6500	6000	7200	3900
1/4 X 1/8	10000	12000	6500	6000	7200	3900
1/4	10000	12000	6500	6000	7200	3900
3/8 X 1/8	10000	12000	6500	6000	7200	3900
3/8 X 1/4	10000	12000	6500	6000	7200	3900
3/8	10000	12000	6500	6000	7200	3900
1/2 X 1/8	10000	12000	6500	6000	7200	3900
1/2 X 1/4	10000	12000	6500	6000	7200	3900
1/2 X 3/8	10000	12000	6500	6000	7200	3900
1/2	10000	12000	6500	6000	7200	3900
3/4 X 1/4	10000	12000	6500	6000	7200	3900
3/4 X 3/8	10000	12000	6500	6000	7200	3900
3/4 X 1/2	10000	12000	6500	6000	7200	3900
3/4	10000	12000	6500	6000	7200	3900
1 X 1/4	9000	10800	5850	6000	7200	3900
1 X 3/8	9000	10800	5850	6000	7200	3900
1 X 1/2	9000	10800	5850	6000	7200	3900
1 X 3/4	9000	10800	5850	6000	7200	3900
1	9000	10800	5850	6000	7200	3900
1 1/4 X 1	6500	7800	4225	5000	6000	3250
1 1/4	6500	7800	4225	5000	6000	3250
1 1/2	4000	4800	2600	3000	3600	1950
2	3000	3600	1950	2500	3000	1625



SIZE	STATIC			DYNAMIC		
	STEEL	SS	BRASS	STEEL	SS	BRASS
1/8	10000	10000	6500	6000	6000	3900
1/4 X 1/8	10000	10000	6500	6000	6000	3900
1/4	10000	10000	6500	6000	6000	3900
3/8 X 1/8	9000	9000	5850	6000	6000	3900
3/8 X 1/4	9000	9000	5850	6000	6000	3900
3/8	9000	9000	5850	6000	6000	3900
1/2 X 1/4	8500	8500	5525	6000	6000	3900
1/2 X 3/8	8500	8500	5525	6000	6000	3900
1/2	8500	8500	5525	6000	6000	3900
3/4 X 1/2	5500	5500	3575	4000	4000	2600
3/4	5500	5500	3575	4000	4000	2600
1	4000	4000	2600	3000	3000	1950
1 1/4 X 1	3000	3000	1950	2500	2500	1625
1 1/4	3000	3000	1950	2500	2500	1625
1 1/2	3000	3000	1950	2500	2500	1625
2	3000	3000	1950	2000	2000	1300

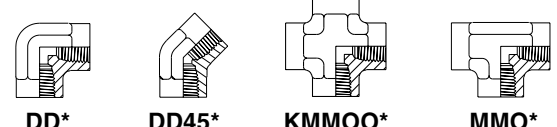

SIZE	STATIC			DYNAMIC		
	STEEL	SS	BRASS	STEEL	SS	BRASS
1/8	7000	7000	4550	5000	5000	3250
1/4 X 1/8	7000	7000	4550	5000	5000	3250
1/4	7000	7000	4550	5000	5000	3250
3/8 X 1/8	6000	6000	3900	4500	4500	2925
3/8 X 1/4	6000	6000	3900	4500	4500	2925
3/8	6000	6000	3900	4500	4500	2925
1/2 X 1/4	4000	4000	2600	3000	3000	1950
1/2 X 3/8	4000	4000	2600	3000	3000	1950
1/2	4000	4000	2600	3000	3000	1950
3/4 X 1/2	4000	4000	2600	3000	3000	1950
3/4	4000	4000	2600	3000	3000	1950
1	2250	2250	1463	1750	1750	1138
1 1/4 X 1	2000	2000	1300	1500	1500	975
1 1/4	2000	2000	1300	1500	1500	975
1 1/2	2000	2000	1300	1500	1500	975
2	1250	1250	813	1000	1000	650

* Shaped connectors (elbows, tees and crosses) with pipe threads have low reliability for leak free operation in dynamic systems. For total leak free reliability in such systems, connectors with o-ring sealing such as SAE straight thread or SAE four bolt split flange are recommended.

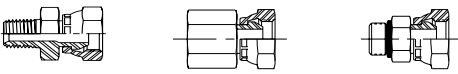

Recommended Working Pressure, PSIG

						
	STATIC			DYNAMIC		
SIZE	STEEL	SS	BRASS	STEEL	SS	BRASS
2 - 2	6650	7980	4323	5000	6000	3250
2 - 4	6650	7980	4323	5000	6000	3250
4 - 2	6650	7980	4323	5000	6000	3250
4 - 4	6650	7980	4323	5000	6000	3250
4 - 6	5320	6384	3458	4000	4800	2600
6 - 4	5320	6384	3458	4000	4800	2600
6 - 6	5320	6384	3458	4000	4800	2600
6 - 8	4655	5586	3026	3500	4200	2275
8 - 6	4655	5586	3026	3500	4200	2275
8 - 8	4655	5586	3026	3500	4200	2275
8 - 12	2993	3591	1945	2250	2700	1463
12 - 8	2993	3591	1945	2250	2700	1463
12 - 12	2993	3591	1945	2250	2700	1463
12 - 16	2660	3192	1729	2000	2400	1300
16 - 12	2660	3192	1729	2000	2400	1300
16 - 16	2660	3192	1729	2000	2400	1300
16 - 20	2161	2594	1405	1625	1950	1056
20 - 16	2161	2594	1405	1625	1950	1056
20 - 20	2161	2594	1405	1625	1950	1056
24 - 20	1663	1995	1081	1250	1500	813
24 - 24	1663	1995	1081	1250	1500	813
32 - 32	1496	1796	973	1125	1350	731

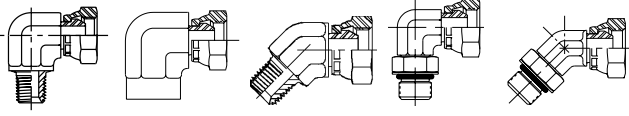
						
	STATIC			DYNAMIC		
SIZE	STEEL	SS	BRASS	STEEL	SS	BRASS
2 - 2	6650	6650	4323	5000	5000	3250
4 - 2	6650	6650	4323	5000	5000	3250
4 - 4	6650	6650	4323	5000	5000	3250
4 - 6	5320	5320	3458	4000	4000	2600
6 - 4	5320	5320	3458	4000	4000	2600
6 - 6	5320	5320	3458	4000	4000	2600
6 - 8	4655	4655	3026	3500	3500	2275
8 - 6	4655	4655	3026	3500	3500	2275
8 - 8	4655	4655	3026	3500	3500	2275
8 - 12	2993	2993	1945	2250	2250	1463
12 - 6	2993	2993	1945	2250	2250	1463
12 - 8	2993	2993	1945	2250	2250	1463
12 - 12	2993	2993	1945	2250	2250	1463
16 - 12	2660	2660	1729	2000	2000	1300
16 - 16	2660	2660	1729	2000	2000	1300
20 - 20	2161	2161	1405	1625	1625	1056
24 - 24	1663	1663	1081	1250	1250	813
32 - 32	1496	1496	973	1125	1125	731

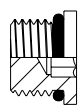
						
	STATIC			DYNAMIC		
SIZE	STEEL	SS	BRASS	STEEL	SS	BRASS
2	10000	12000	6500	6000	6000	3900
3	10000	12000	6500	6000	6000	3900
4	10000	12000	6500	6000	6000	3900
5	9000	10800	5850	6000	6000	3900
6	9000	10800	5850	6000	6000	3900
8	9000	10800	5850	6000	6000	3900
10	8000	9600	5200	6000	6000	3900
12	8000	9600	5200	6000	6000	3900
14	7000	8400	4550	5500	5500	3575
16	7000	8400	4550	5500	5500	3575
20	5000	6000	3250	4000	4000	2600
24	4000	4800	2600	3000	3000	1950
32	2500	3000	1625	2000	2000	1300

Recommended Working Pressure, PSIG

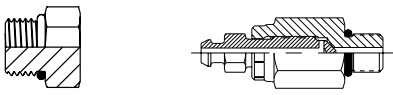

P5ON P5ONBA

SIZE	STATIC			DYNAMIC		
	STEEL	SS	BRASS	STEEL	SS	BRASS
2	10000	12000	6500	6000	7200	3900
3	10000	12000	6500	6000	7200	3900
4	10000	12000	6500	6000	7200	3900
5	9000	10800	5850	6000	7200	3900
6	9000	10800	5850	6000	7200	3900
8	9000	10800	5850	6000	7200	3900
10	8000	9600	5200	6000	7200	3900
12	8000	9600	5200	6000	7200	3900
14	7000	8400	4550	5500	6600	3575
16	7000	8400	4550	5500	6600	3575
20	5000	6000	3250	4000	4800	2600
24	4000	4800	2600	3000	3600	1950
32	2500	3000	1625	2000	2400	1300

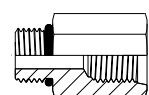

F5OG5

SIZE	STATIC			DYNAMIC		
	STEEL	SS	BRASS	STEEL	SS	BRASS
4 - 4	6000	7200	3900	4500	5400	2925
4 - 5	6000	7200	3900	4500	5400	2925
4 - 6	6000	7200	3900	4500	5400	2925
6 - 4	6000	7200	3900	4500	5400	2925
6 - 8	5000	6000	3250	4000	4800	2600
8 - 6	6000	7200	3900	4500	5400	2925
8 - 10	4000	4800	2600	3000	3600	1950
10 - 6	6000	7200	3900	5000	6000	3250
10 - 8	5000	6000	3250	4000	4800	2600
10 - 12	4500	5400	2925	3500	4200	2275
12 - 8	6000	7200	3900	4500	5400	2925
12 - 10	4000	4800	2600	3000	3600	1950
12 - 14	3000	3600	1950	2000	2400	1300
12 - 16	3000	3600	1950	2000	2400	1300
14 - 10	5000	6000	3250	4000	4800	2600
14 - 12	4500	5400	2925	3500	4200	2275
16 - 8	6000	7200	3900	5000	6000	3250
16 - 12	4500	5400	2925	3500	4200	2275
16 - 20	3500	4200	2275	2500	3000	1625
20 - 6	4000	4800	2600	3000	3600	1950
20 - 10	4000	4800	2600	3000	3600	1950
20 - 12	4000	4800	2600	3000	3600	1950
20 - 16	3000	3600	1950	2000	2400	1300
20 - 24	2000	2400	1300	1500	1800	975
24 - 12	3000	3600	1950	2000	2400	1300
24 - 16	3000	3600	1950	2000	2400	1300
24 - 20	3000	3600	1950	2000	2400	1300
32 - 24	2000	2400	1300	1500	1800	975

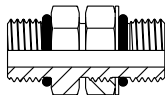

F5OHAO

SIZE	STATIC			DYNAMIC		
	STEEL	SS	BRASS	STEEL	SS	BRASS
2	6500	7800	4225	5000	6000	3250
3	6500	7800	4225	5000	6000	3250
4	6500	7800	4225	5000	6000	3250
5	6000	7200	3900	5000	6000	3250
6	6000	7200	3900	5000	6000	3250
8	6000	7200	3900	5000	6000	3250
10	5500	6600	3575	4500	5400	2925
12	5000	6000	3250	4000	4800	2600
14	4000	4800	2600	3000	3600	1950
16	4000	4800	2600	3000	3600	1950
20	3500	4200	2275	2500	3000	1625
24	2500	3000	1625	2000	2400	1300
32	2000	2400	1300	1500	1800	975

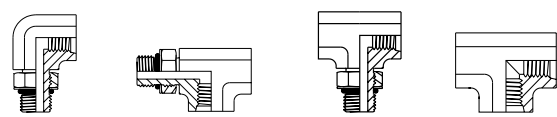

AOEG5 AOG5JG5 G5G5JAO G5G5JG5

SIZE	STATIC			DYNAMIC		
	STEEL	SS	BRASS	STEEL	SS	BRASS
4	6500	6500	4225	5000	5000	3250
6	6000	6000	3900	5000	5000	3250
8	6000	6000	3900	5000	5000	3250
10	5500	5500	3575	4500	4500	2925
12	4000	4000	2600	3000	3000	1950
16	4000	4000	2600	3000	3000	1950

For pressure ratings for adapters not shown, please [contact the Tube Fittings Division](#).



How to Order

How to Order Industrial Pipe Fittings and Adapters

Nomenclature

Pipe fitting part numbers are constructed from symbols that identify the size and style of the fitting and material used.

Sizes

2 (1/8") through 32 (2"). Tube sizes are determined by the number of sixteenths of an inch in the tube O.D.

Materials

Type 316 Stainless Steel, Steel and Brass. Pipe fittings for special applications can be furnished in almost any material suitable for machining.

Example

Fitting needed — (Pipe fitting) — Steel Male Connector for 1/4" Female Port to 1/8" Female Port.

Part number: 1/4 x 1/8 FF

<u>1/4</u>	<u>X</u>	<u>1/8</u>	<u>FF</u>	—	<u>S</u>	<u>BP</u>
1/4" male pipe thread		1/8" male pipe thread	pipe nipple		Material steel	Bulk Pack (where avail.)

Crosses and Tees

For tees — first size the run (1 to 2) and then the branch (3). For crosses — first size the run (1 to 2) and then the branch (3 to 4).

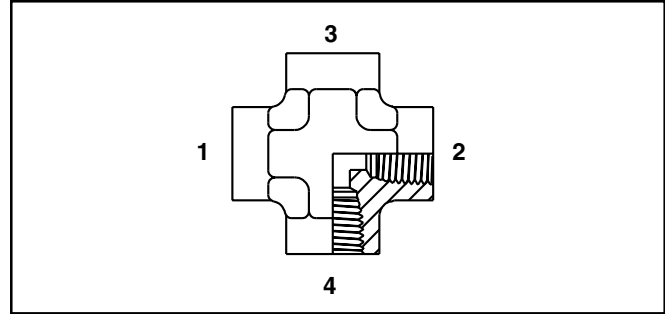

Special Fittings

If design or configuration is questionable please provide a detailed sketch, drawing or sample part to [the Tube Fittings Division](#).

Male Pipe Elbow

CR

Male pipe thread / male pipe thread
SAE 140237*

*Not shown in SAE J514, but coded per SAE J846.

All dimensions are in inches

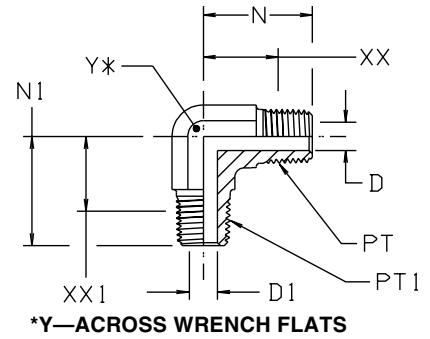

TUBE FITTING PART #	PT PORT THD NPTF	PT1 PORT THD NPTF	D DRILL (inch)	D1 DRILL (inch)	N (inch)	N1 (inch)	XX AFTER ASSY (inch)	XX1 AFTER ASSY (inch)	Y (inch)	STANDARD MATERIAL FROM STOCK		
										S	SS	B
1/8 CR	1/8-27	1/8-27	0.187	0.187	0.78	0.78	0.55	0.55	7/16	•	•	•
1/4 CR	1/4-18	1/4-18	0.281	0.281	1.09	1.09	0.75	0.75	9/16	•	•	•
3/8 CR	3/8-18	3/8-18	0.406	0.406	1.22	1.22	0.87	0.87	3/4	•	•	•
3/8 x 1/4 CR	3/8-18	1/4-18	0.406	0.281	1.22	1.22	0.87	0.87	3/4	•	•	•
1/2 CR	1/2-14	1/2-14	0.531	0.531	1.47	1.47	1.01	1.01	7/8	•	•	•
1/2 x 3/8 CR	1/2-14	3/8-18	0.531	0.406	1.47	1.28	1.01	0.82	7/8	•	•	•
3/4 CR	3/4-14	3/4-14	0.719	0.719	1.59	1.59	1.11	1.11	1 1/16	•	•	•
3/4 x 1/2 CR	3/4-14	1/2-14	0.719	0.531	1.59	1.47	1.11	0.99	1 1/16	•	•	•
1 CR	1-11 1/2	1-11 1/2	0.938	0.938	1.97	1.97	1.40	1.40	1 5/8	•	•	•
1 x 3/4 CR	1-11 1/2	3/4-14	0.938	0.719	1.97	1.78	1.40	1.30	1 5/16	•	•	•
1 1/4 CR	1 1/4-11 1/2	1 1/4-11 1/2	1.250	1.250	2.22	2.22	1.63	1.63	1 7/8	•	•	•
1 1/2 CR	1 1/2-11 1/2	1 1/2-11 1/2	1.500	1.500	2.34	2.34	1.75	1.75	1 7/8	•	•	•



Pipe Nipple

FF

Male pipe thread / male pipe thread
SAE 140137

All dimensions are in inches

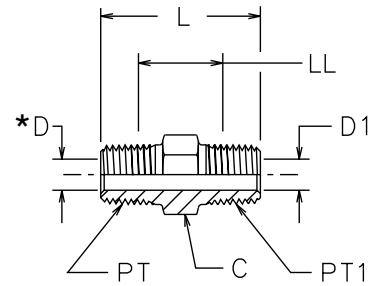

* D1 may be substituted for D where D1 is smaller than D.

TUBE FITTING PART #	HOSE FITTING PART #	PT PORT THD NPTF	PT1 PORT THD NPTF	C HEX (inch)	D DRILL (inch)	D1 DRILL (inch)	L (inch)	LL AFTER ASSY (inch)	STANDARD MATERIAL FROM STOCK		
									S	SS	B
1/8 FF	0101-2-2	1/8-27	1/8-27	7/16	0.188	0.188	1.06	0.59	•	•	•
1/4 x 1/8 FF	0101-2-4	1/4-18	1/8-27	5/8	0.281	0.188	1.25	0.68	•	•	•
1/4 FF	0101-4-4	1/4-18	1/4-18	5/8	0.281	0.281	1.45	0.77	•	•	•
3/8 x 1/8 FF	0101-2-6	3/8-18	1/8-27	3/4	0.406	0.188	1.45	0.87	•	•	•
3/8 x 1/4 FF	0101-4-6	3/8-18	1/4-18	3/4	0.406	0.281	1.45	0.76	•	•	•
3/8 FF	0101-6-6	3/8-18	3/8-18	3/4	0.406	0.406	1.45	0.75	•	•	•
1/2 x 1/8 FF	0101-2-8	1/2-14	1/8-27	7/8	0.531	0.188	1.52	0.83	•	•	•
1/2 x 3/8 FF	0101-6-8	1/2-14	3/8-18	7/8	0.531	0.406	1.70	0.89	•	•	•
1/2 x 1/4 FF	0101-4-8	1/2-14	1/4-18	7/8	0.531	0.281	1.70	0.90	•	•	•
1/2 FF	0101-8-8	1/2-14	1/2-14	7/8	0.531	0.531	1.89	0.96	•	•	•
3/4 x 1/4 FF	0101-4-12	3/4-14	1/4-18	1 1/8	0.719	0.281	1.78	0.96	•	•	•
3/4 x 3/8 FF	0101-6-12	3/4-14	1/4-18	1 1/8	0.719	0.406	1.78	0.95	•	•	•
3/4 x 1/2 FF	0101-8-12	3/4-14	1/2-14	1 1/8	0.719	0.281	1.96	0.84	•	•	•
3/4 FF	0101-12-12	3/4-14	3/4-14	1 1/8	0.719	0.719	1.96	0.70	•	•	•
1 FF	0101-16-16	1-11 1/2	1-11 1/2	1 3/8	0.938	0.938	2.34	1.19	•	•	•
1 x 1/4	0101-4-16	1-11 1/2	1/4-18	1 3/8	0.938	0.281	1.96	1.05	•	•	•
1 x 3/8 FF	0101-6-16	1-11 1/2	3/8-18	1 3/8	0.938	0.406	1.96	1.04	•	•	•
1 x 1/2 FF	0101-8-16	1-11 1/2	1/2-14	1 3/8	0.938	0.531	2.09	1.06	•	•	•
1 x 3/4 FF	0101-12-16	1-11 1/2	3/4-14	1 3/8	0.719	0.719	2.09	1.04	•	•	•
1 1/4 x 1 FF	0101-16-20	1 1/4-11 1/2	1-11 1/2	1 3/4	1.250	0.938	2.45	1.28	•	•	•
1 1/4 FF	0101-20-20	1 1/4-11 1/2	1 1/4-11 1/2	1 3/4	1.250	1.250	2.48	1.29	•	•	•
1-1/2 x 1 FF	0101-16-24	1 1/2-11 1/2	1-11 1/2	2	1.500	0.938	2.55	1.38	•	•	•
1 1/2 FF	0101-24-24	1 1/2-11 1/2	1 1/2-11 1/2	2	1.500	1.500	2.61	1.42	•	•	•
2 FF	0101-32-32	2-11 1/2	2-11 1/2	2 1/2	1.938	1.938	2.83	1.61	•	•	•
2 x 1 1/2 FF	0101-24-32	2-11 1/2	1 1/2-11 1/2	2 1/2	1.500	1.500	2.79	1.58	•	•	•

Long Pipe Nipple FFF

Male pipe thread / male pipe thread

All dimensions are in inches

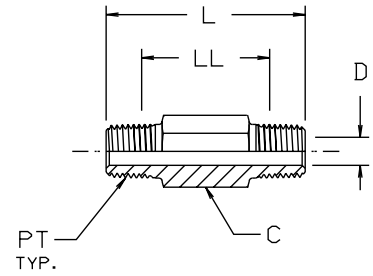

TUBE FITTING PART #	PT PORT THD NPTF	C HEX (inch)	D DRILL (inch)	L (inch)	LL AFTER ASSY (inch)	STANDARD MATERIAL FROM STOCK		
						S	SS	B
1/8 x 1.5 FFF	1/8-27	7/16	0.188	1.5	1.03	•	•	•
1/8 x 2.0 FFF	1/8-27	7/16	0.188	2.0	1.53	•	•	•
1/8 x 2.5 FFF	1/8-27	7/16	0.188	2.5	2.03		•	•
1/8 x 3.0 FFF	1/8-27	7/16	0.188	3.0	2.53		•	•
1/4 x 1.5 FFF	1/4-18	5/8	0.281	1.5	0.82	•	•	•
1/4 x 2.0 FFF	1/4-18	5/8	0.281	2.0	1.32	•	•	•
1/4 x 2.5 FFF	1/4-18	5/8	0.281	2.5	1.82	•	•	•
1/4 x 3.0 FFF	1/4-18	5/8	0.281	3.0	2.32	•	•	•
1/4 x 4.0 FFF	1/4-18	5/8	0.281	4.0	3.32		•	•
3/8 x 2.0 FFF	3/8-18	3/4	0.406	2.0	1.30		•	
3/8 x 3.0 FFF	3/8-18	3/4	0.406	3.0	2.30		•	
3/8 x 3.5 FFF	3/8-18	3/4	0.406	3.5	2.80		•	
3/8 x 4.0 FFF	3/8-18	3/4	0.406	4.0	3.30		•	
1/2 x 2.0 FFF	1/2-14	7/8	0.531	2.0	1.07	•	•	•
1/2 x 2.5 FFF	1/2-14	7/8	0.531	2.5	1.57		•	
1/2 x 3.0 FFF	1/2-14	7/8	0.531	3.0	2.07	•	•	•
1/2 x 4.0 FFF	1/2-14	7/8	0.531	4.0	3.07		•	
1/2 x 6.0 FFF	1/2-14	7/8	0.531	6.0	5.07		•	
3/4 x 3.0 FFF	3/4-14	1 1/8	0.719	3.0	2.04		•	
1 x 3.0 FFF	1-11 1/2	1 3/8	0.938	3.0	1.86		•	



Male Pipe Tee RRS

Male pipe thread (all three ends)

SAE 140437

All dimensions are in inches

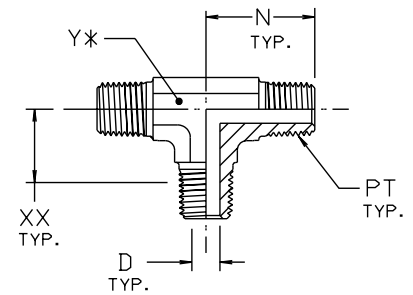

*Y—ACROSS WRENCH FLATS

TUBE FITTING PART #	PT PORT THD NPTF	D DRILL (inch)	N (inch)	XX AFTER ASSY (inch)	Y (inch)	STANDARD MATERIAL FROM STOCK		
						S	SS	B
1/8 RRS	1/8-27	0.188	0.78	0.55	7/16		•	•
1/4 RRS	1/4-18	0.281	1.09	0.75	9/16	•	•	•
3/8 RRS	3/8-18	0.406	1.22	0.87	3/4	•	•	•
1/2 RRS	1/2-14	0.531	1.47	1.01	7/8	•	•	•
3/4 RRS	3/4-14	0.719	1.59	1.11	1 1/16	•	•	

Female Pipe Elbow DD

Female pipe thread / female pipe thread
SAE 140238

All dimensions are in inches

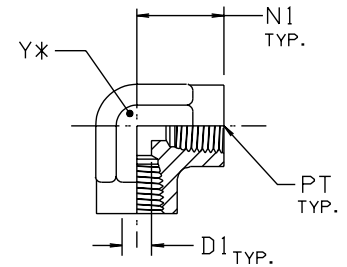

*Y—ACROSS WRENCH FLATS

TUBE FITTING PART #	HOSE FITTING PART #	PT PORT THD NPTF	REF D1 DRILL (inch)	N1 (inch)	Y (inch)	STANDARD MATERIAL FROM STOCK		
						S	SS	B
1/8 DD	2202-2-2	1/8-27	0.328	0.66	9/16	•	•	•
1/4 DD	2202-4-4	1/4-18	0.422	0.88	3/4	•	•	•
3/8 DD	2202-6-6	3/8-18	0.563	1.02	7/8	•	•	•
1/2 DD	2202-8-8	3/8-18	0.688	1.23	1 1/16	•	•	•
1/2 x 3/8 DD	2202-8-6	1/2-14	0.688	1.23	1 1/16	•	•	•
3/4 DD	2202-12-12	3/4-14	0.891	1.36	1 5/8	•	•	•
1 DD	2202-16-16	1-11 1/2	1.125	1.63	1 7/8	•	•	•
1 1/4 DD	2202-20-20	1 1/4-11 1/2	1.469	1.70	1 7/8	•	•	•
1 1/2 DD*	2202-24-24	1 1/2-11 1/2	1.703	2.08	2 1/2	•	•	•

*1 1/2 DD Wrench Flats do not conform to MS/SAE.

45° Female Pipe Elbow DD45

Female pipe thread / female pipe thread
SAE 140338

All dimensions are in inches

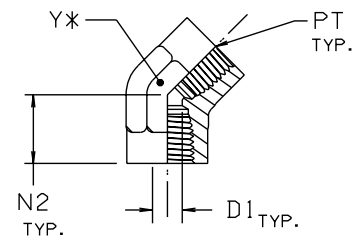

*Y—ACROSS WRENCH FLATS

TUBE FITTING PART #	HOSE FITTING PART #	PT PORT THD NPTF	REF D1 DRILL (inch)	N2 (inch)	Y (inch)	STANDARD MATERIAL FROM STOCK		
						S	SS	B
1/4 DD45	4202-4-4	1/4-18	0.422	0.69	3/4	•		
3/8 DD45	4202-6-6	3/8-18	0.563	0.75	7/8	•		
1/2 DD45	4202-8-8	1/2-14	0.688	0.94	1 1/16	•		
3/4 DD45	4202-12-12	3/4-14	0.891	1.00	1 5/16	•		
1 DD45	4202-16-16	1-11 1/2	1.125	1.19	1 5/8	•		

Pipe Coupling GG

Female pipe thread / female pipe thread
SAE 140138

All dimensions are in inches

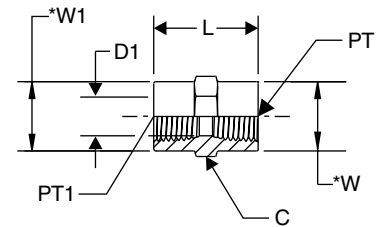

*Turn down is optional per SAE J514.

TUBE FITTING PART #	HOSE FITTING PART #	PT PORT THD NPTF	PT1 PORT THD NPTF	C HEX (inch)	REF D1 DRILL (inch)	L (inch)	W (inch)	W1 (inch)	STANDARD MATERIAL FROM STOCK		
									S	SS	B
1/8 GG	0202-2-2	1/8-27	1/8-27	5/8	0.328	0.75	0.63	0.63	•	•	•
1/4 x 1/8 GG	0202-2-4	1/4-18	1/8-27	3/4	0.328	0.94	0.75	0.63	•	•	•
1/4 GG	0202-4-4	1/4-18	1/4-18	3/4	0.422	1.13	0.75	0.75	•	•	•
3/8 x 1/8 GG	0202-2-6	3/8-18	1/8-27	7/8	0.328	1.03	0.88	0.63	•	•	•
3/8 x 1/4 GG	0202-4-6	3/8-18	1/4-18	7/8	0.422	1.13	0.88	0.75	•	•	•
3/8 GG	0202-6-6	3/8-18	3/8-18	7/8	0.563	1.13	0.88	0.88	•	•	•
1/2 x 1/8 GG	0202-2-8	1/2-14	1/8-27	1 1/8	0.328	1.06	1.13	0.63	•	•	•
1/2 x 1/4 GG	0202-4-8	1/2-14	1/4-18	1 1/8	0.422	1.38	1.13	0.75	•	•	•
1/2 x 3/8 GG	0202-6-8	1/2-14	3/8-18	1 1/8	0.563	1.50	1.13	0.88	•	•	•
1/2 GG	0202-8-8	1/2-14	1/2-14	1 1/8	0.688	1.50	1.13	1.13	•	•	•
3/4 x 1/4 GG	0202-4-12	3/4-14	1/4-18	1 3/8	0.422	1.55	1.36	0.75	•	•	•
3/4 x 1/2 GG	0202-8-12	3/4-14	1/2-14	1 3/8	0.688	1.88	1.36	1.13	•	•	•
3/4 GG	0202-12-12	3/4-14	3/4-14	1 3/8	0.891	1.53	1.38	1.38	•	•	•
1 GG	0202-16-16	1-11 1/2	1-11 1/2	1 5/8	1.125	1.89	1.63	1.63	•	•	•
1 x 1/2 GG	0202-8-16	1-11 1/2	1/2-14	1 5/8	0.688	1.77	1.63	1.13	•	•	•
1 x 3/4 GG	0202-12-16	1-11 1/2	3/4-14	1 5/8	0.891	1.77	1.63	1.38	•	•	•
1 1/4 GG	0202-20-20	1 1/4-11 1/2	1 1/4-11 1/2	2	1.469	1.94	2.00	2.00	•	•	•
1 1/4 x 1 GG	0202-16-20	1 1/4-11 1/2	1-11 1/2	2	1.125	1.94	2.00	1.63	•	•	•
1 1/2 GG	0202-24-24	1 1/2-11 1/2	1 1/2-11 1/2	2 3/8	1.703	1.94	2.38	2.38	•	•	•
1 1/2 x 1 1/4 GG	0202-20-24	1 1/2-11 1/2	1 1/4-11 1/2	2 3/8	1.469	1.93	2.37	2.37	•	•	•
2 GG	0202-32-32	2-11 1/2	2-11 1/2	2 7/8	2.188	1.97	2.88	2.88	•	•	•



Female Pipe Cross KMMOO

Female pipe thread (all four ends)
SAE 140538

All dimensions are in inches

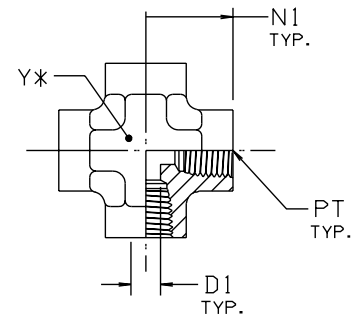

*Y—ACROSS WRENCH FLATS

TUBE FITTING PART #	HOSE FITTING PART #	PT PORT THD NPTF	REF D1 DRILL (inch)	N1 (inch)	Y (inch)	STANDARD MATERIAL FROM STOCK		
						S	SS	B
1/8 KMMOO	022x-2	1/8-27	0.328	0.66	9/16	•	•	•
1/4 KMMOO	022x-4	1/4-18	0.422	0.88	3/4	•	•	•
3/8 KMMOO	022x-6	3/8-18	0.563	1.02	7/8	•	•	•
1/2 KMMOO	022x-8	1/2-14	0.688	1.23	1 1/16	•	•	•
3/4 KMMOO	022x-12	3/4-14	0.891	1.36	1 5/16	•	•	•
1 KMMOO	022x-16	1-11 1/2	1.125	1.63	1 5/8	•	•	•

Female Pipe Tee

MMO

Female pipe thread (all three ends)
SAE 140438

All dimensions are in inches

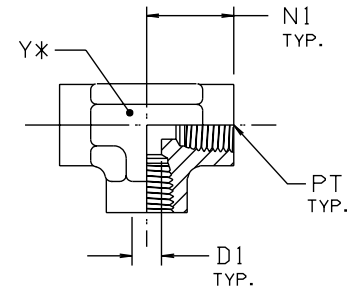

*Y—ACROSS WRENCH FLATS

TUBE FITTING PART #	HOSE FITTING PART #	PT PORT THD NPTF	REF D1 DRILL (inch)	N1 (inch)	Y (inch)	STANDARD MATERIAL FROM STOCK		
						S	SS	B
1/8 MMO	022T-2-2	1/8-27	0.328	0.66	9/16	•	•	•
1/4 MMO	022T-4-4	1/4-18	0.422	0.88	3/4	•	•	•
3/8 MMO	022T-6-6	3/8-18	0.563	1.02	7/8	•	•	•
1/2 MMO	022T-8-8	1/2-14	0.688	1.23	1 1/16	•	•	•
3/4 MMO	022T-12-12	3/4-14	0.891	1.36	1 5/16	•	•	•
1 MMO	022T-16-16	1-11 1/2	1.125	1.63	1 5/8	•	•	•
1 1/4 MMO	022T-20-20	1 1/4-11 1/2	1.469	1.70	1 7/8	•	•	•
1 1/2 MMO*	022T-24-24	1 1/2-11 1/2	1.703	2.08	2 1/2	•	•	•

*1 1/2 MMO Wrench Flats do not conform to MS/SAE.

Street Elbow

CD

Male pipe thread / female pipe thread
SAE 140239

All dimensions are in inches

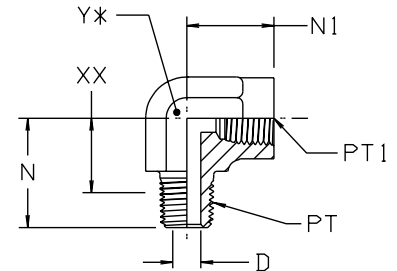

*Y—ACROSS WRENCH FLATS

TUBE FITTING PART #	HOSE FITTING PART #	PT PORT THD NPTF	PT1 PORT THD NPTF	D DRILL (inch)	N (inch)	N1 (inch)	XX AFTER ASSY (inch)	Y (inch)	STANDARD MATERIAL FROM STOCK		
									S	SS	B
1/8 CD	2102-2-2	1/8-27	1/8-27	0.188	0.78	0.66	0.55	9/16	•	•	•
1/8 x 1/4 CD	2102-2-4	1/8-27	1/4-18	0.188	0.88	0.88	0.65	9/16	•	•	•
1/4 CD	2102-4-4	1/4-18	1/4-18	0.281	1.09	0.88	0.75	3/4	•	•	•
1/4 x 1/8 CD	2102-4-2	1/4-18	1/8-27	0.281	1.09	0.66	0.75	9/16	•	•	•
1/4 x 1/2 CD	2102-4-8	1/4-18	1/2-14	0.281	1.28	1.23	0.89	1 1/16	•	•	•
1/4 x 3/8 CD	2102-4-6	1/4-18	3/8-18	0.281	1.22	1.01	0.87	7/8	•	•	•
3/8 CD	2102-6-6	3/8-18	3/8-18	0.406	1.22	1.02	0.87	7/8	•	•	•
3/8 x 1/4 CD	2102-6-4	3/8-18	1/4-18	0.406	1.22	0.88	0.87	3/4	•	•	•
3/8 x 1/2 CD	2102-6-8	3/8-18	1/2-14	0.406	1.28	1.23	0.93	1 1/16	•	•	•
1/2 CD	2102-8-8	1/2-14	1/2-14	0.531	1.47	1.23	1.01	1 1/16	•	•	•
1/2 x 3/8 CD	2102-8-6	1/2-14	3/8-18	0.531	1.48	1.25	1.02	7/8	•	•	•
1/2 x 3/4 CD	2102-8-12	1/2-14	3/4-14	0.531	1.59	1.36	1.13	1 5/16	•	•	•
3/4 CD	2102-12-12	3/4-14	3/4-14	0.719	1.59	1.36	1.11	1 5/16	•	•	•
3/4 x 1/2 CD	2102-12-8	3/4-14	1/2-14	0.719	1.59	1.23	1.11	1 1/16	•	•	•
1 CD	2102-16-16	1-11 1/2	1-11 1/2	0.938	1.97	1.63	1.40	1 5/8	•	•	•
1 1/4 CD	2102-20-20	1 1/4-11 1/2	1 1/4-11 1/2	1.250	2.38	1.70	1.79	1 7/8	•	•	•
1 1/2 CD*	2102-24-24	1 1/2-11 1/2	1 1/2-11 1/2	1.500	2.64	2.08	2.05	2 1/2	•	•	•

*1 1/2 CD Wrench Flats do not conform to MS/SAE.

45° Street Elbow

CD45

Male pipe thread / female pipe thread
SAE 140339

All dimensions are in inches

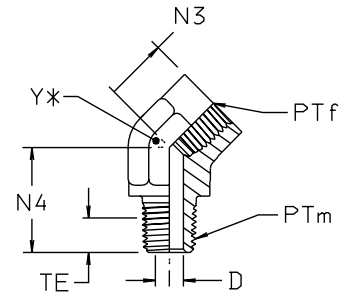

*Y—ACROSS WRENCH FLATS

TUBE FITTING PART #	HOSE FITTING PART #	PTm PORT THD NPTF	PTf PORT THD NPTF	D DRILL (inch)	N3 (inch)	N4 (inch)	TE AFTER ASSY (inch)	Y (inch)	STANDARD MATERIAL FROM STOCK		
									S	SS	B
1/8 CD45	3102-2-2	1/8-27	1/8-27	0.188	0.47	0.72	0.23	9/16	•	•	•
1/4 CD45	3102-4-4	1/4-18	1/4-18	0.281	0.63	1.05	0.34	3/4	•	•	•
3/8 CD45	3102-6-6	3/8-18	3/8-18	0.406	0.72	1.06	0.35	7/8	•	•	•
1/2 CD45	3102-8-8	1/2-14	1/2-14	0.531	0.91	1.34	0.46	1 1/16	•	•	•
3/4 CD45	3102-12-12	3/4-14	3/4-14	0.719	0.97	1.38	0.48	1 5/16	•	•	•
1 CD45	3102-16-16	1-11 1/2	1-11 1/2	0.938	1.13	1.72	0.57	1 5/8	•	•	•
1 1/4 CD45	3102-20-20	1 1/4-11 1/2	1 1/4-11 1/2	1.250	1.63	1.80	0.59	1 7/8	•	•	•

Expander / Adapter

FG

Female pipe thread / male pipe thread
SAE 140139

All dimensions are in inches

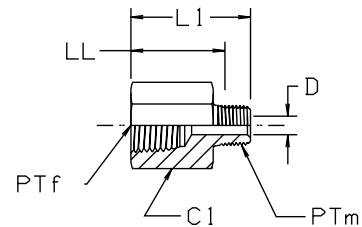

TUBE FITTING PART #	HOSE FITTING PART #	PTm PORT THD NPTF	PTf PORT THD NPTF	C1 HEX (inch)	D DRILL (inch)	L1 (inch)	LL (inch)	STANDARD MATERIAL FROM STOCK		
								S	SS	B
1/8 x 1/16 FG	0201-2-1	1/16-27	1/8-27	5/8	0.109	1.03	0.80		•	
1/8 FG	0201-2-2	1/8-27	1/8-27	5/8	0.188	1.03	0.80		•	
1/4 x 1/8 FG	0201-4-2	1/8-27	1/4-18	3/4	0.188	1.20	0.97	•	•	•
1/4 FG	0201-4-4	1/4-18	1/4-18	3/4	0.281	1.39	1.05		•	•
3/8 x 1/8 FG	0201-6-2	1/8-27	3/8-18	7/8	0.188	1.25	1.02		•	•
3/8 x 1/4 FG	0201-6-4	1/4-18	3/8-18	7/8	0.281	1.44	1.10	•	•	•
3/8 FG	0201-6-6	3/8-18	3/8-18	7/8	0.406	1.44	1.09	•	•	•
1/2 x 1/8 FG	0201-8-2	1/8-27	1/2-14	1 1/8	0.188	1.50	1.27	•	•	•
1/2 x 1/4 FG	0201-8-4	1/4-18	1/2-14	1 1/8	0.281	1.69	1.35	•	•	•
1/2 x 3/8 FG	0201-8-6	3/8-18	1/2-14	1 1/8	0.406	1.69	1.34	•	•	•
1/2 FG	0201-8-8	1/2-14	1/2-14	1 1/8	0.531	1.87	1.23		•	•
3/4 FG	0201-12-12	3/4-14	3/4-14	1 3/8	0.719	1.93	1.45		•	•
3/4 x 1/4 FG	0201-12-4	1/4-18	3/4-14	1 3/8	0.281	1.75	1.41	•	•	•
3/4 x 3/8 FG	0201-12-6	3/8-18	3/4-14	1 3/8	0.406	1.75	1.40		•	•
3/4 x 1/2 FG	0201-12-8	1/2-14	3/4-14	1 3/8	0.531	1.94	1.48	•	•	•
1 FG	0201-16-16	1-11 1/2	1-11 1/2	1 5/8	0.938	2.37	1.80		•	•
1 x 1/4 FG	0201-16-4	1/4-18	1-11 1/2	1 5/8	0.281	2.01	1.67		•	•
1 x 1/2 FG	0201-16-8	1/2-14	1-11 1/2	1 5/8	0.531	2.19	1.73	•	•	•
1 x 3/4 FG	0201-16-12	3/4-14	1-11 1/2	1 5/8	0.719	2.19	1.71	•	•	•
1 1/4 FG	0201-20-20	1 1/4-11 1/2	1 1/4-11 1/2	2	1.250	2.50	1.91	•	•	•
1 1/4 x 1 FG	0201-20-16	1-11 1/2	1 1/4-11 1/2	2	0.938	2.47	1.90	•	•	•
1 1/2 x 1 FG	0201-24-16	1-11 1/2	1 1/2-11 1/2	2 3/8	0.938	2.47	1.90		•	•
2 FG	0201-24-24	2-11 1/2	2-11 1/2	2 7/8	1.938	2.66	2.06		•	•



Male Branch Tee

MMS

Male pipe thread / female pipe thread
SAE 140425

All dimensions are in inches

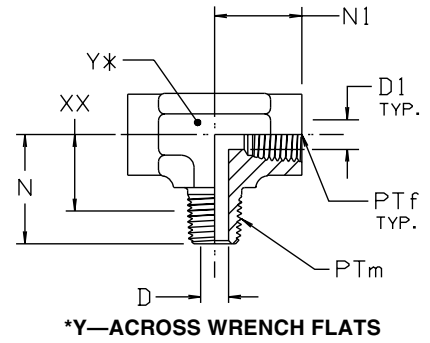

TUBE FITTING PART #	HOSE FITTING PART #	PTm PORT THD NPTF	PTf PORT THD NPTF	D DRILL (inch)	REF D1 DRILL (inch)	N (inch)	N1 (inch)	XX AFTER ASSY (inch)	Y (inch)	STANDARD MATERIAL FROM STOCK		
										S	SS	B
1/8 MMS	212T-2-2	1/8-27	1/8-27	0.188	0.328	0.78	0.66	0.55	9/16	•	•	•
1/4 MMS	212T-4-4	1/4-18	1/4-18	0.281	0.422	1.09	0.88	0.75	3/4	•	•	•
3/8 MMS	212T-6-6	3/8-18	3/8-18	0.406	0.563	1.22	1.02	0.87	7/8	•	•	•
1/2 MMS	212T-8-8	1/2-14	1/2-14	0.531	0.688	1.47	1.23	1.01	1 1/16	•	•	•
3/4 MMS	212T-12-12	3/4-14	3/4-14	0.719	0.891	1.59	1.36	1.11	1 5/16	•	•	•
1 MMS	212T-16-16	1-11 1/2	1-11 1/2	0.938	1.125	1.97	1.63	1.40	1 5/8	•	•	•

Male Run Tee

MRO

Male pipe thread / female pipe thread
SAE 140424

All dimensions are in inches

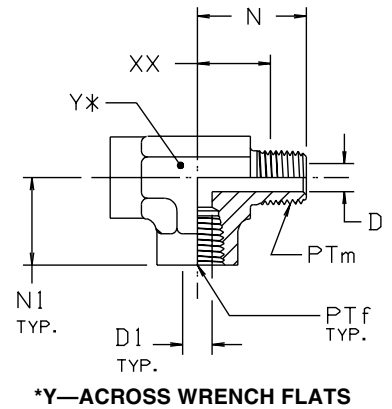

TUBE FITTING PART #	HOSE FITTING PART #	PTm PORT THD NPTF	PTf PORT THD NPTF	D DRILL (inch)	REF D1 DRILL (inch)	N (inch)	N1 (inch)	XX AFTER ASSY (inch)	Y (inch)	STANDARD MATERIAL FROM STOCK		
										S	SS	B
1/8 MRO	012T-2-2	1/8-27	1/8-27	0.188	0.328	0.78	0.66	0.55	9/16	•	•	•
1/4 MRO	012T-4-4	1/4-18	1/4-18	0.281	0.422	1.09	0.88	0.75	3/4	•	•	•
3/8 MRO	012T-6-6	3/8-18	3/8-18	0.406	0.563	1.22	1.02	0.87	7/8	•	•	•
1/2 MRO	012T-8-8	1/2-14	1/2-14	0.531	0.688	1.47	1.23	1.01	1 1/16	•	•	•
3/4 MRO	012T-10-10	3/4-14	3/4-14	0.719	0.891	1.59	1.36	1.11	1 5/16	•	•	•
1 MRO	012T-16-16	1-11 1/2	1-11 1/2	0.938	1.125	1.97	1.63	1.40	1 5/8	•	•	•
1 1/4 MRO	012T-20-20	1 1/4-11 1/2	1 1/4-11 1/2	1.250	1.469	2.38	1.70	1.11	1 7/8	•	•	•
1 1/2 MRO	012T-24-24	1 1/2-11 1/2	1 1/2-11 1/2	1.500	1.719	2.64	2.08	2.05	2 1/2	•	•	•

Pipe Thread Reducer PTR

Male pipe thread / female pipe thread
SAE 140140

All dimensions are in inches

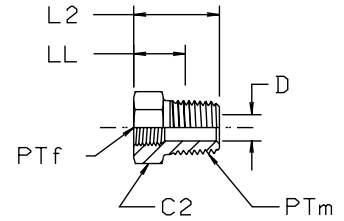

TUBE FITTING PART #	HOSE FITTING PART #	PTm PORT THD NPTF	PTf PORT THD NPTF	C2 HEX (inch)	D DRILL (inch)	L2 (inch)	LL (inch)	STANDARD MATERIAL FROM STOCK		
								S	SS	B
1/4 x 1/8 PTR	0102-4-2	1/4-18	1/8-27	5/8	0.328	0.86	0.52	•	•	•
3/8 x 1/8 PTR	0102-6-2	3/8-18	1/8-27	3/4	0.328	0.86	0.51	•	•	•
3/8 x 1/4 PTR	0102-6-4	3/8-18	1/4-18	3/4	0.422	0.86	0.51	•	•	•
1/2 x 1/8 PTR	0102-8-2	1/2-14	1/8-27	7/8	0.328	1.11	0.65	•	•	•
1/2 x 1/4 PTR	0102-8-4	1/2-14	1/4-18	7/8	0.422	1.11	0.65	•	•	•
1/2 x 3/8 PTR	0102-8-6	1/2-14	3/8-18	7/8	0.563	1.11	0.65	•	•	•
3/4 x 1/8 PTR	0102-12-2	3/4-14	1/8-18	1 1/8	0.328	1.17	0.69	•	•	•
3/4 x 1/4 PTR	0102-12-4	3/4-14	1/4-18	1 1/8	0.422	1.17	0.69	•	•	•
3/4 x 3/8 PTR	0102-12-6	3/4-14	3/8-18	1 1/8	0.563	1.17	0.69	•	•	•
3/4 x 1/2 PTR	0102-12-8	3/4-14	1/2-14	1 1/8	0.688	1.17	0.69	•	•	•
1 x 1/8 PTR	0102-16-2	1-11 1/2	1/8-18	1 3/8	0.328	1.36	0.79	•	•	•
1 x 1/4 PTR	0102-16-4	1-11 1/2	1/4-18	1 3/8	0.422	1.36	0.79	•	•	•
1 x 3/8 PTR	0102-16-6	1-11 1/2	3/8-18	1 3/8	0.563	1.36	0.79	•	•	•
1 x 1/2 PTR	0102-16-8	1-11 1/2	1/2-14	1 3/8	0.688	1.36	0.79	•	•	•
1 x 3/4 PTR	0102-16-12	1-11 1/2	3/4-14	1 3/8	0.891	1.36	0.79	•	•	•
1 1/4 x 1/4 PTR	0102-20-4	1 1/4-11 1/2	1/4-18	1 3/4	0.328	1.47	0.53	•	•	•
1 1/4 x 3/8 PTR	0102-20-6	1 1/4-11 1/2	3/8-18	1 3/4	0.563	1.47	0.87	•	•	•
1 1/4 x 1/2 PTR	0102-20-8	1 1/4-11 1/2	1/2-14	1 3/4	0.688	1.47	0.87	•	•	•
1 1/4 x 3/4 PTR	0102-20-12	1 1/4-11 1/2	3/4-14	1 3/4	0.891	1.47	0.88	•	•	•
1 1/4 x 1 PTR	0102-20-16	1 1/4-11 1/2	1-11 1/2	1 3/4	1.125	1.47	0.88	•	•	•
1 1/2 x 1/4 PTR	0102-24-12	1 1/2-11 1/2	1/4-18	2	0.328	1.52	0.92	•	•	•
1 1/2 x 3/8 PTR	0102-24-6	1 1/2-11 1/2	3/8-18	2	0.563	1.58	0.98	•	•	•
1 1/2 x 1/2 PTR	0102-24-8	1 1/2-11 1/2	1/2-14	2	0.688	1.58	0.98	•	•	•
1 1/2 x 3/4 PTR	0102-24-12	1 1/2-11 1/2	3/4-14	2	0.891	1.58	0.98	•	•	•
1 1/2 x 1 PTR	0102-24-16	1 1/2-11 1/2	1-11 1/2	2	1.125	1.58	0.99	•	•	•
1 1/2 x 1 1/4 PTR	0102-24-20	1 1/2-11 1/2	1 1/4-11 1/2	2	1.469	1.58	0.99	•	•	•
2 x 1/2 PTR	0102-32-8	2-11 1/2	1/2-14	2 1/2	0.688	1.75	1.14	•	•	•
2 x 3/4 PTR	0102-32-12	2-11 1/2	3/4-14	2 1/2	0.891	1.75	1.14	•	•	•
2 x 1 PTR	0102-32-16	2-11 1/2	1-11 1/2	2 1/2	1.125	1.75	1.14	•	•	•
2 x 1 1/4 PTR	0102-32-20	2-11 1/2	1 1/4-11 1/2	2 1/2	1.719	1.75	1.14	•	•	•
2 x 1 1/2 PTR	0102-32-24	2-11 1/2	1 1/2-11 1/2	2 1/2	1.719	1.75	1.14	•	•	•



Straight Thread Union

F5OHAO

Straight thread O-ring / straight thread O-ring adjustable

Part Number Information
F5HA - Body only
F5OHAO - Assembled with O-rings

All dimensions are in inches

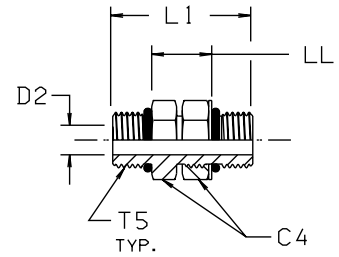

TUBE FITTING PART #	HOSE FITTING PART #	T5m PORT THD UN/UNF-2A	C4 HEX (inch)	D2 DRILL	L1 (inch)	LL AFTER ASSY (inch)	STANDARD MATERIAL FROM STOCK		
							S	SS	B
4 F5OHAO	0505-4-4	7/16-20	9/16	0.203	1.22	0.47	•	•	
6 F5OHAO	0505-6-6	9/16-18	11/16	0.297	1.41	0.59	•	•	
8 F5OHAO	0505-8-8	3/4-16	7/8	0.422	1.56	0.63	•	•	
10 F5OHAO	0505-10-10	7/8-14	1	0.484	1.81	0.75	•	•	
12 F5OHAO	0505-12-12	1 1/16-12	1 1/4	0.656	2.13	0.89	•	•	
16 F5OHAO	0505-16-16	1 5/16-12	1 1/2	0.875	2.13	0.89	•	•	
20 F5OHAO	0505-20-20	1 5/8-12	1 7/8	1.078	2.13	0.89	•	•	
24 F5OHAO	0505-24-24	1 7/8-12	2 1/8	1.344	2.13	0.89	•	•	
32 F5OHAO	0505-32-32	2 1/2-12	2 3/4	1.813	2.13	0.89	•	•	

Straight Thread Reducer / Expander

F5OG5

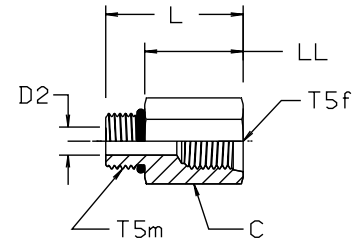

Straight thread O-ring / female straight thread O-ring boss

SAE 090136

Part Number Information

F5G5 - Body only

F5OG5 - Assembled with O-ring

All dimensions are in inches

TUBE FITTING PART #	HOSE FITTING PART #	T5m PORT THD UN/UNF-2A	T5f PORT THD UN/UNF-2B	C HEX (inch)	D2 DRILL	L1 (inch)	LL AFTER ASSY (inch)	STANDARD MATERIAL FROM STOCK		
								S	SS	B
4-4 F5OG5	0510-4-4	7/16-20	7/16-20	11/16	0.172	1.08	0.72		•	
4-6 F5OG5	0510-4-6	7/16-20	9/16-18	13/16	0.172	1.16	0.80	•	•	
6-4 F5OG5	0510-6-4	9/16-18	7/16-20	11/16	0.297	1.03	0.64	•	•	
6-8 F5OG5	0510-6-8	9/16-18	3/4-16	1 1/16	0.297	1.38	0.99	•	•	
8-6 F5OG5	0510-8-6	3/4-16	9/16-18	7/8	0.438	1.13	0.69	•	•	
8-10 F5OG5	0510-8-10	3/4-16	7/8-14	1 1/8	0.391	1.56	1.12	•	•	
10-6 F5OG5	0510-10-6	7/8-14	9/16-18	1	0.484	0.81	0.31	•	•	
10-8 F5OG5	0510-10-8	7/8-14	3/4-16	1	0.563	1.31	0.81	•	•	
10-12 F5OG5	0510-10-12	7/8-14	1 1/16-12	1 3/8	0.484	1.69	1.19	•	•	
12-8 F5OG5	0510-12-8	1 1/16-12	3/4-16	1 1/4	0.625	1.00	0.41	•	•	
12-10 F5OG5	0510-12-10	1 1/16-12	7/8-14	1 1/4	0.625	1.53	0.94	•	•	
12-16 F5OG5	0510-12-16	1 1/16-12	1 5/16-12	1 5/8	0.625	1.88	1.29	•	•	
16-8 F5OG5	0510-16-8	1 5/16-12	3/4-16	1 1/2	0.750	1.00	0.41	•	•	
16-10 F5OG5	0510-16-10	1 5/16-12	7/8-14	1 1/2	0.797	1.00	0.41	•	•	
16-12 F5OG5	0510-16-12	1 5/16-12	1 1/16-12	1 1/2	0.750	1.75	1.16	•	•	
16-20 F5OG5	0510-16-20	1 5/16-12	1 5/8-12	2 1/8	0.875	1.97	1.38	•	•	
20-6 F5OG5	0510-20-6	1 5/8-12	9/16-18	1 7/8	1.063	1.00	0.41	•	•	
20-12 F5OG5	0510-20-12	1 5/8-12	1 1/16-12	1 7/8	1.063	1.00	0.41	•	•	
20-16 F5OG5	0510-20-16	1 5/8-12	1 5/16-12	1 7/8	1.063	1.00	0.41	•	•	
20-24 F5OG5	0510-20-24	1 5/8-12	1 7/8-12	2 1/2	1.063	1.88	1.29	•	•	
24-12 F5OG5	0510-24-12	1 7/8-12	1 1/16-12	2 1/8	1.250	1.00	0.41	•	•	
24-16 F5OG5	0510-24-16	1 7/8-12	1 5/16-12	2 1/8	1.250	1.00	0.41	•	•	
24-20 F5OG5	0510-24-20	1 7/8-12	1 5/8-12	2 1/8	1.250	1.75	1.16	•	•	
32/24 F5OG5	0510-32-24	2 1/2-12	1 7/8-12	2 3/4	1.780	1.00	0.38	•	•	



Straight Thread Branch Tee

G5G5JAO

Straight thread O-ring / female SAE straight thread

Part Number Information
G5G5JA - Body only
G5G5JAO - Assembled with O-ring

All dimensions are in inches

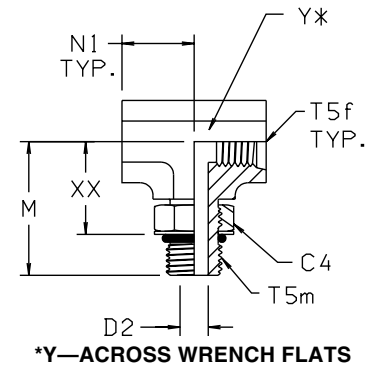

TUBE FITTING PART #	T5m PORT THD UN/UNF-2A	T5f PORT THD UN/UNF-2B	C4	D2 DRILL (inch)	M (inch)	N1 (inch)	XX AFTER ASSY (inch)	Y (inch)	STANDARD MATERIAL FROM STOCK		
									S	SS	B
4 G5G5JAO	7/16-20	7/16-20	9/16	0.172	1.23	0.63	0.84	3/4	•		
6 G5G5JAO	9/16-18	9/16-18	11/16	0.297	1.38	0.75	0.96	7/8	•		
8 G5G5JAO	3/4-16	3/4-16	7/8	0.391	1.59	0.88	1.10	1 1/16	•		
10 G5G5JAO	7/8-14	7/8-14	1	0.484	1.81	1.02	1.25	1 1/16	•		
12 G5G5JAO	1 1/16-12	1 1/16-12	1 1/4	0.609	2.00	1.21	1.35	1 5/16	•		
16 G5G5JAO	1 5/16-12	1 5/16-12	1 1/2	0.844	2.25	1.33	1.60	1 5/8	•		

Female Straight Thread Tee

G5G5JG5

Female SAE straight thread - all 3 ends

Part Number Information
G5G5JG5 - Body only

All dimensions are in inches

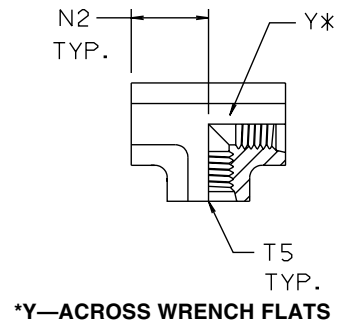

TUBE FITTING PART #	T5 PORT THD UN/UNF-2B	N2 (inch)	Y (inch)	STANDARD MATERIAL FROM STOCK		
				S	SS	B
4 G5G5JG5	7/16-20	0.74	3/4	•		
6 G5G5JG5	9/16-18	0.86	3/4	•		
8 G5G5JG5	3/4-16	1.03	1 1/16	•		
10 G5G5JG5	7/8-14	1.18	1 1/16	•		
12 G5G5JG5	1 1/16-12	1.39	1 5/16	•		
16 G5G5JG5	1 5/16-12	1.52	1 5/8	•		

Straight Thread Elbow

AOEG5

Straight thread O-ring / female SAE straight thread

Part Number Information
AEG5 - Body only
AOEG5 - Assembled with O-ring

All dimensions are in inches

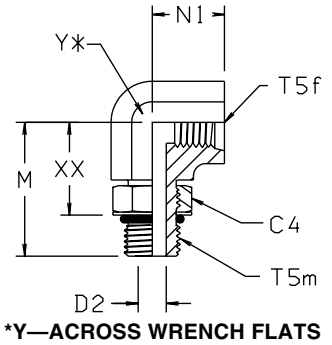

TUBE FITTING PART #	HOSE FITTING PART #	T5m PORT THD UN/UNF-2A	T5f PORT THD UN/UNF-2B	C4 HEX (inch)	D2 DRILL	M (inch)	N1 (inch)	XX AFTER ASSY (inch)	Y (inch)	STANDARD MATERIAL FROM STOCK		
										S	SS	B
4 AOEG5	2510-4-4	7/16-20	7/16-20	9/16	0.172	1.23	0.63	0.84	3/4	•		
6 AOEG5	2510-6-6	9/16-18	9/16-18	11/16	0.297	1.38	0.75	0.96	7/8	•		
8 AOEG5	2510-8-8	3/4-16	3/4-16	7/8	0.391	1.59	0.88	1.10	1 1/16	•		
10 AOEG5	2510-10-10	7/8-14	7/8-14	1	0.484	1.81	1.02	1.25	1 1/16	•		
12 AOEG5	2510-12-12	1 1/16-12	1 1/16-12	1 1/4	0.609	2.00	1.21	1.35	1 5/16	•		
16 AOEG5	2510-16-16	1 5/16-12	1 5/16-12	1 1/2	0.844	2.26	1.33	1.61	1 5/8	•		



Straight Thread Run Tee

AOG5JG5

Straight thread O-ring / female SAE straight thread

Part Number Information
AG5JG5 - Body only
AOG5JG5 - Assembled with O-ring

All dimensions are in inches

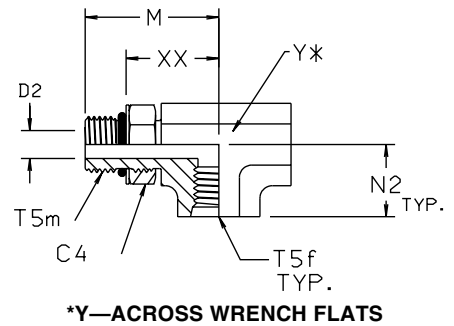

TUBE FITTING PART #	T5m PORT THD UN/UNF-2A	T5f PORT THD UN/UNF-2B	C4 HEX (inch)	D2 DRILL (inch)	M (inch)	N2 (inch)	XX AFTER ASSY (inch)	Y (inch)	STANDARD MATERIAL FROM STOCK		
									S	SS	B
4 AOG5JG5	7/16-20	7/16-20	9/16	0.172	1.23	0.74	0.84	3/4	•		
6 AOG5JG5	9/16-18	9/16-18	11/16	0.297	1.38	0.86	0.96	7/8	•		
8 AOG5JG5	3/4-16	3/4-16	7/8	0.391	1.59	1.03	1.10	1 1/16	•		
10 AOG5JG5	7/8-14	7/8-14	1	0.484	1.81	1.18	1.25	1 1/16	•		
12 AOG5JG5	1 1/16-12	1 1/16-12	1 1/4	0.609	2.00	1.39	1.35	1 5/16	•		
16 AOG5JG5	1 5/16-12	1 5/16-12	1 1/2	0.844	2.25	1.52	1.60	1 5/8	•		

Hollow Hex Pipe Plug

HHP

Male pipe thread
SAE 130109N

All dimensions are in inches

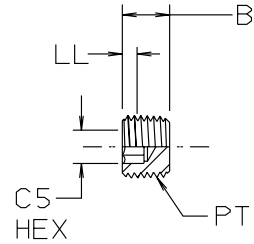

C5—ACROSS INTERNAL HEX FLATS

TUBE FITTING PART #	HOSE FITTING PART #	PT PORT THD NPTF	B (inch)	C5 INTERNAL HEX (inch)	LL (inch)	STANDARD MATERIAL FROM STOCK		
						S	SS	B
1/16 HHP	01HP-1	1/16-27	0.30	5/32	0.07	•		
1/8 HHP	01HP-2	1/8-27	0.30	3/16	0.07	•	•	•
1/4 HHP	01HP-4	1/4-18	0.46	1/4	0.12	•	•	•
3/8 HHP	01HP-6	3/8-18	0.46	5/16	0.11	•	•	
1/2 HHP	01HP-8	1/2-14	0.61	3/8	0.15	•		
3/4 HHP	01HP-12	3/4-14	0.62	9/16	0.14	•		
1 HHP	01HP-16	1-11 1/2	0.77	1 3/8	0.19		•	

Hex Head Pipe Plug

HP

Male pipe thread
SAE 130109E

All dimensions are in inches

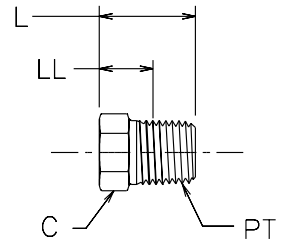

TUBE FITTING PART #	HOSE FITTING PART #	PT PORT THD NPTF	C HEX (inch)	L (inch)	LL (inch)	STANDARD MATERIAL FROM STOCK		
						S	SS	B
1/8 HP	01CP-2	1/8-27	7/16	0.56	0.33	•	•	•
1/4 HP	01CP-4	1/4-18	9/16	0.75	0.41	•	•	•
3/8 HP	01CP-6	3/8-18	11/16	0.78	0.43	•	•	•
1/2 HP	01CP-8	1/2-14	7/8	0.97	0.51	•	•	•
3/4 HP	01CP-12	3/4-14	1 1/16	1.06	0.58	•	•	•
1 HP	01CP-16	1-11 1/2	1 3/8	1.25	0.68	•	•	•
1 1/4 HP	01CP-20	1 1/4-11 1/2	1 3/4	1.41	0.82	•	•	
1 1/2 HP	01CP-24	1 1/2-11 1/2	2	1.50	0.86	•	•	
2 HP	01CP-32	2-11 1/2	2 1/2	1.69	1.08		•	

*Brass plugs may have a partial drill.

**Stainless steel plugs may have a drill.

Hollow Hex Plug HP50N

Hollow hex / straight thread O-ring

SAE 090109B

Part Number Information

HP5N - Body only

HP50N - Assembled with O-ring

All dimensions are in inches

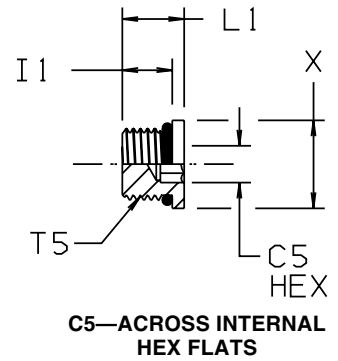

TUBE FITTING PART #	HOSE FITTING PART #	T5 PORT THD UN/UNF-2A	C5 HEX (inch)	I1 (inch)	L1 (inch)	X DIA (inch)	STANDARD MATERIAL FROM STOCK		
							S	SS	B
2 HP50N	05HP-2	5/16-24	1/8	0.30	0.39	0.44	•	•	
3 HP50N	05HP-3	3/8-24	1/8	0.30	0.39	0.50	•	•	
4 HP50N	05HP-4	7/16-20	3/16	0.36	0.46	0.56	•	•	
5 HP50N	05HP-5	1/2-20	3/16	0.36	0.46	0.63	•	•	
6 HP50N	05HP-6	9/16-18	1/4	0.40	0.49	0.69	•	•	
8 HP50N	05HP-8	3/4-16	5/16	0.44	0.57	0.88	•	•	
10 HP50N	05HP-10	7/8-14	3/8	0.50	0.63	1.00	•	•	
12 HP50N	05HP-12	1 1/16-12	9/16	0.59	0.75	1.25	•	•	
14 HP50N	05HP-14	1 3/16-12	9/16	0.59	0.75	1.38	•	•	
16 HP50N	05HP-16	1 5/16-12	5/8	0.59	0.75	1.50	•	•	
20 HP50N	05HP-20	1 5/8-12	3/4	0.59	0.75	1.88	•	•	
24 HP50N	05HP-24	1 7/8-12	3/4	0.59	0.77	2.13	•	•	

Hex Head Plug P50N

Hex head / straight thread O-ring

SAE 090109A

Part Number Information

P5N - Body only

P50N - Assembled with O-ring

All dimensions are in inches

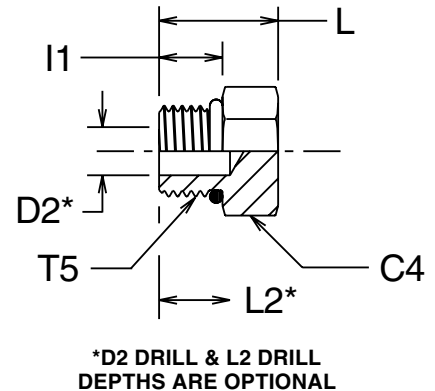

TUBE FITTING PART #	HOSE FITTING PART #	T5 PORT THD UN/UNF-2A	C4 HEX (inch)	D2 DRILL (inch)	I1 (inch)	L (inch)	L2 (inch)	STANDARD MATERIAL FROM STOCK		
								S	SS	B
2 P50N	05CP-2	5/16-24	7/16	0.094	0.30	0.61	0.38	•	•	
3 P50N	05CP-3	3/8-24	1/2	0.125	0.30	0.61	0.34	•	•	
4 P50N	05CP-4	7/16-20	9/16	0.203	0.36	0.67	0.41	•	•	
5 P50N	05CP-5	1/2-20	5/8	0.234	0.36	0.67	0.39	•	•	
6 P50N	05CP-6	9/16-18	11/16	0.297	0.39	0.73	0.44	•	•	
8 P50N	05CP-8	3/4-16	7/8	0.422	0.44	0.80	0.44	•	•	
10 P50N	05CP-10	7/8-14	1	0.500	0.50	0.94	0.47	•	•	
12 P50N	05CP-12	1 1/16-12	1 1/4	0.656	0.59	1.09	0.59	•	•	
14 P50N	05CP-14	1 3/16-12	1 3/8	0.718	0.59	1.09	0.56	•	•	
16 P50N	05CP-16	1 5/16-12	1 1/2	0.875	0.59	1.13	0.50	•	•	
20 P50N	05CP-20	1 5/8-12	1 7/8	1.094	0.59	1.20	0.41	•	•	
24 P50N	05CP-24	1 7/8-12	2 1/8	1.344	0.59	1.27	0.34	•	•	
32 P50N	05CP-32	2 1/2-12	2 3/4	1.812	0.59	1.44	0.13	•	•	



Hex Pipe Cap HPC

Female pipe thread

All dimensions are in inches

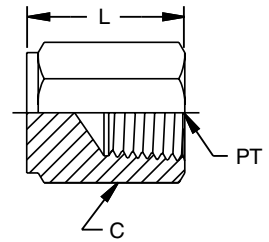

TUBE FITTING PART #	PT PORT THD NPTF	C HEX	L	STANDARD MATERIAL FROM STOCK		
				S	SS	B
1/8 HPC	1/8-27	9/16	0.75		•	
1/4 HPC	1/4-18	3/4	0.91		•	
3/8 HPC	3/8-18	7/8	1.03		•	
1/2 HPC	1/2-14	1 1/16	1.34		•	
3/4 HPC	3/4-14	1 1/4	1.44		•	
1 HPC	1-11 1/2	1 5/8	1.68		•	
1 1/2 HPC	1 1/2-1 1/2	2.375	1.92		•	

Straight Thread O-Ring Bleed Adapter P5ONBA

Male straight thread O-ring

Part Number Information
P5NBA - Body Only
P5ONBA - Assembled with O-ring

All dimensions are in inches

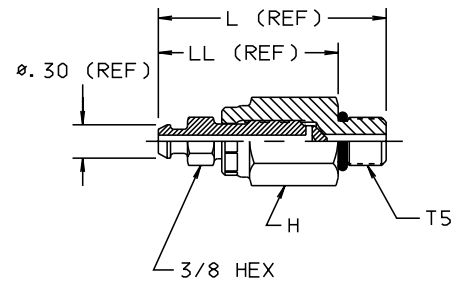

TUBE FITTING PART #	T5 PORT THD UN/UNF-2A	H HEX (inch)	L REF (inch)	LL REF (inch)	STANDARD MATERIAL FROM STOCK		
					S	SS	B
4 P5ONBA	7/16-20	11/16	2.05	1.62	•		

Tightening Torque for bleed screw is 35-40 in-lb.

Male Pipe Bleed Adapter HPBA

Male pipe thread

All dimensions are in inches

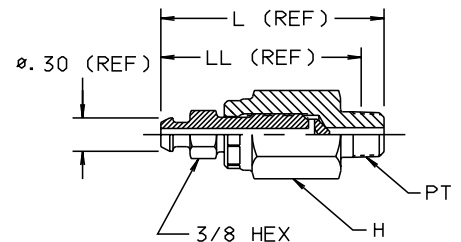

TUBE FITTING PART #	PT PORT THREAD	H HEX (inch)	L REF (inch)	LL REF (inch)	STANDARD MATERIAL FROM STOCK		
					S	SS	B
1/4 HPBA	1/4-18	11/16	2.2	1.86	•		

Tightening Torque for bleed screw is 35-40 in-lb.

Male Pipe Adapter

0107

NPSM swivel / male pipe thread

SAE 140130

Part Number Information
0107 - Body only

All dimensions are in inches

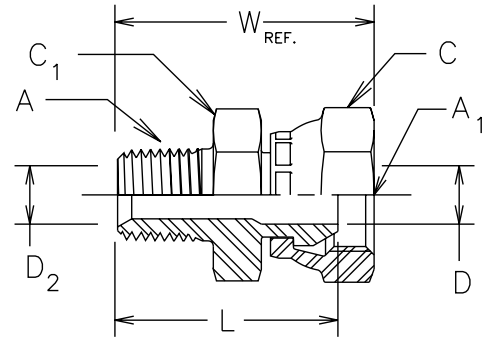

TUBE FITTING PART #	A PIPE THD NPTF	A1 SWIVEL THD NPSM	C HEX (inch)	C1 HEX (inch)	D DRILL (inch)	D2 DRILL (inch)	L (inch)	W (inch)	STANDARD MATERIAL FROM STOCK		
									S	SS	B
0107-2-2	1/8-27	1/8-27	9/16	9/16	0.156	0.188	0.94	1.09	•	•	
0107-2-4	1/8-27	1/4-18	11/16	5/8	0.219	0.188	1.06	1.24	•	•	
0107-4-2	1/4-18	1/8-27	9/16	11/16	0.156	0.281	1.24	1.39	•	•	
0107-4-4	1/4-18	1/4-18	11/16	11/16	0.219	0.281	1.25	1.43	•	•	
0107-4-6	1/4-18	3/8-18	7/8	13/16	0.344	0.281	1.25	1.45	•	•	
0107-4-8	1/4-18	1/2-14	1	15/16	0.469	0.281	1.44	1.44	•	•	
0107-6-4	3/8-18	1/4-18	11/16	11/16	0.219	0.406	1.31	1.49	•	•	
0107-6-6	3/8-18	3/8-18	7/8	7/8	0.344	0.406	1.31	1.51	•	•	
0107-6-8	3/8-18	1/2-14	1	15/16	0.469	0.406	1.44	1.73	•	•	
0107-8-6	1/2-14	3/8-18	7/8	7/8	0.344	0.531	1.50	1.70	•	•	
0107-8-8	1/2-14	1/2-14	1	1	0.469	0.531	1.62	1.91	•	•	
0107-8-12	1/2-14	3/4-14	1 1/4	1 1/4	0.641	0.531	1.69	2.04	•	•	
0107-12-8	3/4-14	1/2-14	1	1 1/8	0.469	0.719	1.62	1.91	•	•	
0107-12-12	3/4-14	3/4-14	1 1/4	1 1/4	0.641	0.719	1.69	2.04	•	•	
0107-12-16	3/4-14	1-11 1/2	1 1/2	1 1/2	0.844	0.719	1.80	2.17	•	•	
0107-16-12	1-11 1/2	3/4-14	1 1/2	1 3/8	0.641	0.938	1.94	2.29	•	•	
0107-16-16	1-11 1/2	1-11 1/2	1 1/2	1 1/2	0.844	0.938	2.00	2.37	•	•	
0107-16-20	1-11 1/2	1 1/4-11 1/2	1 7/8	1 3/4	1.141	0.938	2.00	2.38	•	•	
0107-20-16	1 1/4-11 1/2	1-11 1/2	1 1/2	1 7/8	0.844	1.250	2.09	2.46	•	•	
0107-20-20	1 1/4-11 1/2	1 1/4-11 1/2	1 7/8	1 7/8	1.141	1.250	2.09	2.47	•	•	
0107-24-20	1 1/2-11 1/2	1 1/4-11 1/2	1 7/8	2 1/8	1.141	1.500	2.13	2.51	•	•	
0107-24-24	1 1/2-11 1/2	1 1/2-11 1/2	2 1/8	2 1/8	1.359	1.500	2.19	2.61	•	•	
0107-32-32	2-11 1/2	2-11 1/2	2 5/8	2 5/8	1.813	1.938	2.37	2.80	•	•	



Male Pipe Elbow

2107

NPSM swivel / male pipe thread

SAE 140230

Part Number Information
2107 - Body only

All dimensions are in inches

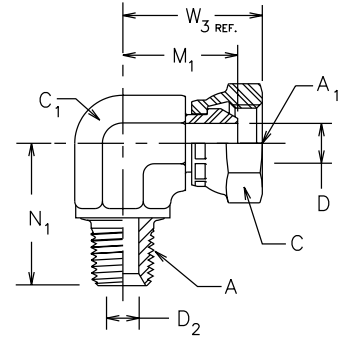

TUBE FITTING PART #	A PIPE THD NPTF	A1 SWIVEL THD NPSM	C HEX (inch)	C1 HEX (inch)	D DRILL (inch)	D2 DRILL (inch)	M1 (inch)	N1 (inch)	W3 (inch)	STANDARD MATERIAL FROM STOCK		
										S	SS	B
2107-2-2	1/8-27	1/8-27	9/16	7/16	0.156	0.188	0.70	0.72	0.85	•	•	
2107-4-2	1/4-18	1/8-27	9/16	9/16	0.219	0.188	0.88	0.90	1.05	•	•	
2107-4-4	1/4-18	1/4-18	11/16	9/16	0.219	0.281	0.88	1.09	1.06	•	•	
2107-4-6	1/4-18	3/8-18	7/8	3/4	0.344	0.281	0.99	1.09	1.28	•	•	
2107-6-4	3/8-18	1/4-18	11/16	3/4	0.219	0.406	0.99	1.22	1.17	•	•	
2107-6-6	3/8-18	3/8-18	7/8	3/4	0.344	0.406	0.99	1.22	1.28	•	•	
2107-6-8	3/8-18	1/2-14	1	3/4	0.469	0.406	1.04	1.22	1.33	•	•	
2107-8-6	1/2-14	3/8-18	7/8	7/8	0.344	0.531	1.06	1.47	1.35	•	•	
2107-8-8	1/2-14	1/2-14	1	7/8	0.469	0.531	1.11	1.47	1.40	•	•	
2107-8-12	1/2-14	3/4-14	1 1/4	1 1/16	0.641	0.531	1.30	1.47	1.65	•	•	
2107-12-6	3/4-14	3/8-18	7/8	1 1/16	0.344	0.719	1.19	1.59	1.48	•	•	
2107-12-8	3/4-14	1/2-14	1	1 1/16	0.469	0.719	1.24	1.59	1.53	•	•	
2107-12-12	3/4-14	3/4-14	1 1/4	1 1/16	0.641	0.719	1.30	1.59	1.65	•	•	
2107-16-12	1-11 1/2	3/4-14	1 1/4	1 5/16	0.641	0.938	1.47	1.97	1.82	•	•	
2107-16-16	1-11 1/2	1-11 1/2	1 1/2	1 5/16	0.844	0.938	1.54	1.97	1.91	•	•	
2107-20-20	1 1/4-11 1/2	1 1/4-11 1/2	1 7/8	1 5/8	1.141	1.250	1.73	2.38	2.11	•	•	
2107-24-24	1 1/2-11 1/2	1 1/2-11 1/2	2 1/8	1 7/8	1.359	1.500	1.89	2.64	2.31	•	•	
2107-32-32	2-11 1/2	2-11 1/2	2 5/8	2 1/2	1.813	1.938	2.27	3.00	2.70	•	•	

45° Male Pipe Elbow

3107

NPSM swivel / male pipe thread

SAE 140330

Part Number Information
3107 - Body only

All dimensions are in inches

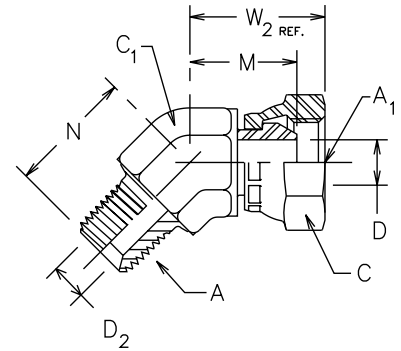

TUBE FITTING PART #	A PIPE THD NPTF	A1 SWIVEL THD NPSM	C HEX (inch)	C1 HEX forg (inch)	D DRILL (inch)	D2 DRILL (inch)	M (inch)	N (inch)	W2 (inch)	STANDARD MATERIAL FROM STOCK		
										S	SS	B
3107-2-2	1/8-27	1/8-27	9/16	7/16	0.156	0.188	0.62	0.52	0.77	•		
3107-4-4	1/4-18	1/4-18	11/16	9/16	0.219	0.281	0.73	0.86	0.91	•	•	
3107-6-6	3/8-18	3/8-18	7/8	3/4	0.344	0.406	0.81	0.95	1.10	•	•	
3107-8-6	1/2-14	3/8-18	7/8	7/8	0.344	0.531	0.81	1.17	1.10	•		
3107-8-8	1/2-14	1-2/14	1	7/8	0.469	0.531	0.88	1.17	1.17	•	•	
3107-8-12	1/2-14	3/4-14	1 1/4	1 1/16	0.641	0.531	0.87	1.20	1.22	•		
3107-12-8	3/4-14	1/2-14	1	1 1/16	0.469	0.719	0.94	1.20	1.23	•		
3107-12-12	3/4-14	3/4-14	1 1/4	1 1/16	0.641	0.719	1.02	1.20	1.37	•	•	
3107-16-12	1-11 1/2	3/4-14	1 1/4	1 5/16	0.641	0.938	1.12	1.48	1.47	•		
3107-16-16	1-11 1/2	1-11 1/2	1 1/2	1 5/16	0.844	0.938	1.15	1.48	1.52	•	•	
3107-20-20	1 1/4-11 1/2	1 1/4-11 1/2	1 7/8	1 5/8	1.141	1.250	1.23	1.67	1.61	•		
3107-24-24	1 1/2-11 1/2	1 1/2-11 1/2	2 1/8	1 7/8	1.359	1.500	1.35	1.77	1.77	•	•	
3107-32-32	2-11 1/2	2-11 1/2	2 5/8	2 1/2	1.813	1.938	1.46	2.11	1.89	•		



Female Pipe Adapter

0207

NPSM swivel / female pipe thread

SAE 140131

Part Number Information
0207 - Body only

All dimensions are in inches

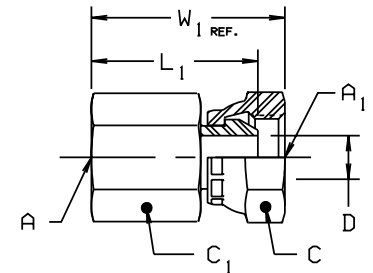

TUBE FITTING PART #	A PIPE THD NPTF	A1 SWIVEL THD NPSM	C HEX (inch)	C1 HEX (inch)	D DRILL (inch)	L1 (inch)	W1 (inch)	STANDARD MATERIAL FROM STOCK		
								S	SS	B
0207-2-2	1/8-27	1/8-27	9/16	9/16	0.156	0.870	1.02	•	•	
0207-4-4	1/4-18	1/4-18	11/16	11/16	0.219	1.25	1.43	•	•	
0207-6-4	3/8-18	1/4-18	11/16	7/8	0.219	1.31	1.49	•	•	
0207-6-6	3/8-18	3/8-18	7/8	7/8	0.344	1.31	1.51	•	•	
0207-8-6	1/2-14	3/8-18	7/8	1	0.344	1.31	1.51	•	•	
0207-8-8	1/2-14	1-2/14	1	1	0.469	1.50	1.79	•	•	
0207-12-12	3/4-14	3/4-14	1 1/4	1 1/4	0.641	1.62	1.97	•	•	
0207-16-16	1-11 1/2	1-11 1/2	1 1/2	1 1/2	0.844	2.00	2.37	•	•	
0207-20-20	1 1/4-11 1/2	1 1/4-11 1/2	1 7/8	1 7/8	1.141	2.00	2.38	•	•	
0207-24-24	1 1/2-11 1/2	1 1/2-11 1/2	2 1/8	2 1/8	1.359	2.00	2.42	•	•	
0207-32-32	2-11 1/2	2-11 1/2	2 5/8	2 5/8	1.813	2.12	2.55	•	•	

Female Pipe Elbow

2207

NPSM swivel / female pipe thread

SAE 140231

Part Number Information
2207 - Body only

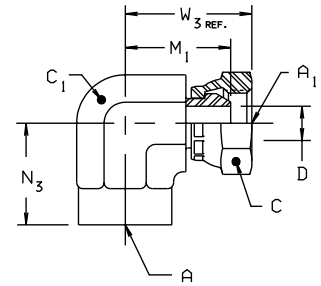

All dimensions are in inches

TUBE FITTING PART #	A PIPE THD NPTF	A1 SWIVEL THD NPSM	C HEX (inch)	C1 HEX (inch)	D DRILL (inch)	M1 (inch)	N3 (inch)	W3 (inch)	STANDARD MATERIAL FROM STOCK		
									S	SS	B
2207-2-2	1/8-27	1/8-27	9/16	9/16	0.156	0.80	0.66	0.95	•		
2207-4-4	1/4-18	1/4-18	11/16	3/4	0.219	0.99	0.88	1.17	•	•	
2207-4-6	1/4-18	3/8-18	7/8	7/8	0.344	1.06	1.01	1.26	•	•	
2207-6-6	3/8-18	3/8-18	7/8	7/8	0.344	1.06	1.02	1.26	•	•	
2207-8-8	1/2-14	1/2-14	1	1 1/16	0.469	1.24	1.23	1.53	•	•	
2207-12-12	3/4-14	3/4-14	1 1/4	1 5/16	0.641	1.47	1.36	1.82	•	•	
2207-16-16	1-11 1/2	1-11 1/2	1 1/2	1 5/8	0.844	1.73	1.62	2.10	•		
2207-20-20	1 1/4-11 1/2	1 1/4-11 1/2	1 7/8	1 7/8	1.141	1.83	1.70	2.21	•		
2207-24-24	1 1/2-11 1/2	1 1/2-11 1/2	2 1/8	2 1/2	1.359	2.41	2.08	2.83	•		
2207-32-32	2-11 1/2	2-11 1/2	2 5/8	2 13/16	1.813	2.57	2.39	3.00	•		

Straight Thread Adapter

0507

NPSM swivel / SAE O-ring boss
SAE 140157

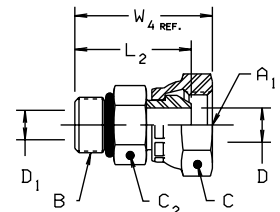

All dimensions are in inches

TUBE FITTING PART #	B PORT THD UN/UNF-2A	A1 SWIVEL THD NPSM	C HEX (inch)	C2 HEX BODY (inch)	D DRILL (inch)	D1 DRILL PORT (inch)	L2 (inch)	W4 (inch)	STANDARD MATERIAL FROM STOCK		
									S	SS	B
0507-4-4	7/16-20	1/4-18	11/16	9/16	0.219	0.219	1.14	1.32	•		
0507-6-4	9/16-18	1/4-18	11/16	11/16	0.219	0.219	1.17	1.35	•		
0507-6-6	9/16-18	3/8-18	7/8	11/16	0.344	0.344	1.17	1.37	•		
0507-6-8	9/16-18	1/2-14	1	3/4	0.297	0.297	1.28	1.57	•		
0507-8-4	3/4-16	1/4-18	11/16	7/8	0.219	0.391	1.25	1.43	•		
0507-8-6	3/4-16	3/8-18	7/8	7/8	0.344	0.344	1.25	1.45	•		
0507-8-8	3/4-16	1/2-14	1	7/8	0.391	0.391	1.27	1.56	•		
0507-8-12	3/4-16	3/4-14	1 1/4	1	0.641	0.391	1.44	1.79	•		
0507-10-8	7/8-14	1/2-14	1	1	0.469	0.469	1.44	1.73	•		
0507-10-12	7/8-14	3/4-14	1 1/4	1 1/4	0.484	0.484	1.62	1.97	•		
0507-12-8	1 1/16-12	1/2-14	1	1 1/4	0.469	0.469	1.59	1.88	•		
0507-12-12	1 1/16-12	3/4-14	1 1/4	1 1/4	0.641	0.641	1.62	1.97	•		
0507-16-16	1 5/16-12	1-11 1/2	1 1/2	1 1/2	0.844	0.844	1.75	2.12	•		
0507-20-20	1 5/8-12	1 1/4-11 1/2	1 7/8	1 7/8	1.078	1.078	1.83	2.21	•		
0507-24-24	1 7/8-12	1 1/2-11 1/2	2 1/8	2 1/8	1.312	1.312	1.97	2.39	•		
0507-32-32	2 1/2-12	2-11 1/2	2 5/8	2 3/4	1.781	1.781	2.06	2.49	•		

Straight Thread Adapter

2507

NPSM swivel / SAE O-ring boss
SAE 140257

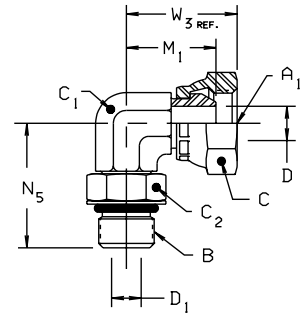

All dimensions are in inches

TUBE FITTING PART #	B PORT THD UN/UNF-2A	A1 SWIVEL THD NPSM	C HEX (inch)	C1 HEX (inch)	C2 HEX (inch)	D DRILL (inch)	D1 DRILL (inch)	M1 (inch)	N5 (inch)	W3 (inch)	STANDARD MATERIAL FROM STOCK		
											S	SS	B
2507-4-4	7/16-20	1/4-18	11/16	7/16	9/16	0.219	0.172	0.79	1.03	0.97	•		
2507-6-4	9/16-18	1/4-18	11/16	9/16	11/16	0.219	0.297	0.88	1.25	1.06	•		
2507-6-6	9/16-18	3/8-18	7/8	9/16	11/16	0.344	0.297	0.90	1.25	1.10	•		
2507-6-8	9/16-18	1/2-14	1	9/16	11/16	0.469	0.297	1.04	1.36	1.33	•		
2507-8-6	3/4-16	3/8-18	7/8	3/4	7/8	0.344	0.391	0.99	1.45	1.19	•		
2507-8-8	3/4-16	1/2-14	1	3/4	7/8	0.469	0.391	1.04	1.45	1.33	•		
2507-8-12	3/4-16	3/4-14	1 1/4	3/4	7/8	0.641	0.391	1.30	1.62	1.65	•		
2507-10-6	7/8-14	3/8-18	7/8	7/8	1	0.344	0.484	1.06	1.70	1.26	•		
2507-10-8	7/8-14	1/2-14	1	7/8	1	0.469	0.484	1.11	1.70	1.40	•		
2507-10-12	7/8-14	3/4-14	1 1/4	7/8	1	0.641	0.484	1.27	1.78	1.62	•		
2507-12-8	1 1/16-12	1/2-14	1	1 1/16	1 1/4	0.469	0.609	1.21	1.94	1.50	•		
2507-12-12	1 1/16-12	3/4-14	1 1/4	1 1/16	1 1/4	0.641	0.609	1.30	1.94	1.65	•		
2507-16-16	1 5/16-12	1-11 1/2	1 1/2	1 5/16	1 1/2	0.844	0.844	1.54	2.05	1.91	•		
2507-20-20	1 5/8-12	1 1/4-11 1/2	1 7/8	1 5/8	1 7/8	1.141	1.078	1.78	2.25	2.16	•		
2507-24-24	1 7/8-12	1 1/2-11 1/2	2 1/8	1 7/8	2 1/8	1.359	1.312	1.89	2.39	2.31	•		

F

45° Straight Thread Adapter

3507

NPSM swivel / SAE O-ring boss
SAE 140357

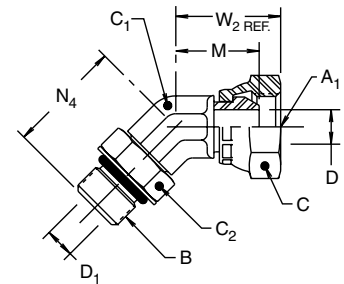

All dimensions are in inches

TUBE FITTING PART #	B PORT THD UN/UNF-2A	A1 SWIVEL THD NPSM	C HEX (inch)	C1 HEX (inch)	C2 HEX (inch)	D DRILL (inch)	D1 DRILL (inch)	M (inch)	N4 (inch)	W2 (inch)	STANDARD MATERIAL FROM STOCK		
											S	SS	B
3507-4-4	7/16-20	1/4-18	11/16	7/16	9/16	0.219	0.172	0.61	1.05	0.79	•		
3507-6-6	9/16-18	3/8-18	7/8	9/16	11/16	0.344	0.297	0.83	1.14	1.03	•		
3507-8-6	3/4-16	3/8-18	7/8	3/4	7/8	0.344	0.391	0.82	1.3	1.02	•		
3507-8-8	3/4-16	1/2-14	1	3/4	7/8	0.469	0.391	0.89	1.30	1.18	•		
3507-8-12	3/4-16	3/4-16	1 1/4	3/4	7/8	0.641	0.391	1.02	1.41	1.37	•		
3507-10-8	7/8-14	1/2-14	1	7/8	1	0.469	0.484	0.88	1.52	1.17	•		
3507-12-12	1 1/16-12	3/4-14	1 1/4	1 1/16	1 1/4	0.641	0.609	1.02	1.73	1.37	•		
3507-16-16	1 5/16-12	1-11 1/2	1 1/2	1 5/16	1 1/2	0.844	0.844	1.15	1.86	1.52	•		

[Click Here](#)
to Go to the First Page
of the Next Section